

# FCC Test Report

**FCC ID** : ACQ-VAP3400  
**Equipment** : 802.11ac 5GHz 4T4R Access Point  
**Model No.** : VAP3400  
**Brand Name** : ARRIS  
**Applicant** : ARRIS Group, Inc.  
**Address** : 101 Tournament Drive, Horsham,  
Pennsylvania, United States, 19044  
**Standard** : 47 CFR FCC Part 15.407  
**Received Date** : May 27, 2014  
**Tested Date** : May 30 ~ Jun. 06, 2014

We, International Certification Corp., would like to declare that the tested sample has been evaluated and in compliance with the requirement of the above standards. The test results contained in this report refer exclusively to the product. It may be duplicated completely for legal use with the approval of the applicant. It shall not be reproduced except in full without the written approval of our laboratory.

Approved & Reviewed by:

  
\_\_\_\_\_  
Gary Chang / Manager



---

## Table of Contents

<b>1</b>	<b>GENERAL DESCRIPTION .....</b>	<b>5</b>
1.1	Information.....	5
1.2	Local Support Equipment List .....	10
1.3	Test Setup Chart .....	10
1.4	The Equipment List .....	11
1.5	Testing Applied Standards .....	12
1.6	Measurement Uncertainty .....	12
<b>2</b>	<b>TEST CONFIGURATION .....</b>	<b>13</b>
2.1	Testing Condition .....	13
2.2	The Worst Test Modes and Channel Details .....	14
<b>3</b>	<b>TRANSMITTER TEST RESULTS.....</b>	<b>15</b>
3.1	Conducted Emissions.....	15
3.2	Emission Bandwidth .....	18
3.3	RF Output Power .....	22
3.4	Peak Power Spectral Density .....	26
3.5	Peak Excursion.....	29
3.6	Transmitter Radiated and Band Edge Emissions .....	34
3.7	Frequency Stability.....	102
<b>4</b>	<b>TEST LABORATORY INFORMATION .....</b>	<b>104</b>

---

## Release Record

Report No.	Version	Description	Issued Date
FR452702AN	Rev. 01	Initial issue	Aug. 12, 2014
FR452702AN	Rev. 02	Revised antenna models of antenna group 1 (page 6)	Nov. 27, 2014

## Summary of Test Results

FCC Rules	Test Items	Measured	Result
15.207	Conducted Emissions	[dBuV]: 0.352MHz 41.64 (Margin -7.27dB) - AV	Pass
15.407(b)(1)(2)(3) 15.209	Radiated Emissions	[dBuV/m at 3m]: 5725.00MHz 53.00 (Margin -1.00dB) – AV [dBuV/m at 3m]: 5350.00MHz 53.00 (Margin -1.00dB) - AV	Pass
15.407(a)(1)(2)(3)	Emission Bandwidth	Meet the requirement of limit	Pass
15.407(a)(1)(2)(3)	RF Output Power	Power [dBm]: 5150~5250MHz: 16.21 5250~5350MHz: 23.03 5470~5725MHz: 23.63	Pass
15.407(a)(1)(2)(3)	Peak Power Spectral Density	Meet the requirement of limit	Pass
15.407(a)(6)	Peak Excursion	Meet the requirement of limit	Pass
15.407(g)	Frequency Stability	Meet the requirement of limit	Pass
15.203	Antenna Requirement	Meet the requirement of limit	Pass

# 1 General Description

## 1.1 Information

### 1.1.1 Specification of the Equipment under Test (EUT)

RF General Information					
IEEE Std. 802.11	Frequency Range (MHz)	Ch. Freq. (MHz)	Channel Number	Transmit Chains (N <sub>TX</sub> )	Data Rate / MCS
a	5150-5250 5250-5350 5470-5725	5180-5240 5260-5320 5500-5720	36-48 [4] 52-64 [4] 100-144 [8]	4	6-54 Mbps
n (HT20)	5150-5250 5250-5350 5470-5725	5180-5240 5260-5320 5500-5720	36-48 [4] 52-64 [4] 100-144 [8]	4	MCS 0-31
n (HT40)	5150-5250 5250-5350 5470-5725	5190-5230 5270-5310 5510-5710	38-46 [2] 54-62 [2] 102-142 [4]	4	MCS 0-31
ac (VHT20)	5150-5250 5250-5350 5470-5725	5180-5240 5260-5320 5500-5720	36-48 [4] 52-64 [4] 100-144 [8]	4	MCS 0-8
ac (VHT40)	5150-5250 5250-5350 5470-5725	5190-5230 5270-5310 5510-5710	38-46 [2] 54-62 [2] 102-142 [4]	4	MCS 0-9
ac (VHT80)	5150-5250 5250-5350 5470-5725	5210 5290 5530~5690	42 [1] 58 [1] 106-138 [2]	4	MCS 0-9

Note 1: RF output power specifies that Maximum Conducted Output Power.  
 Note 2: 802.11a/n/ac uses a combination of OFDM-BPSK, QPSK, 16QAM, 64QAM, 256QAM modulation.  
 Note 3: The device has disabled the channel 5660MHz by S/W.

### 1.1.2 Antenna Details

Ant. Group	Ant. No.	Model	Type	Connector	Operating Frequencies (MHz) / Antenna Gain (dBi)		
					5150~5350	5470~5725	5725~5850
1	1	Mag.Layers - PCA-2108-5G0C1-A1	PCB	MHF PLUG	0	0	0.1
	2	Mag.Layers - PCA-2108-5G0C1-A1	PCB	MHF PLUG	0	0	0.1
	3	Mag.Layers - PCA-2108-5G0C1-A2	PCB	MHF PLUG	0	0	0.1
	4	Mag.Layers - PCA-2108-5G0C1-A2	PCB	MHF PLUG	0	0	0.1
2	1	Airgain - N5X20SC-PK1-G65U	PCB	MHF PLUG	0	-0.1	0
	2	Airgain - N5X20SC-PK1-G65U	PCB	MHF PLUG	0	-0.1	0
	3	Airgain - N5X20SC-PK1-G100U	PCB	MHF PLUG	0	-0.1	0
	4	Airgain - N5X20SC-PK1-G100U	PCB	MHF PLUG	0	-0.1	0

Note:

For Antenna group 1

Above antenna gain value is for single TX antenna. Correlated antenna gain is 6.02dBi for 5150~5350 and 5470~5725 MHz and 6.12dBi for 5725~5850 MHz.

For Antenna group 2

Above antenna gain value is for single TX antenna. Correlated antenna gain is 6.02dBi for 5150~5350 and 5725~5850 MHz and 5.92dBi for 5470~5725 MHz.

### 1.1.3 Power Supply Type of Equipment under Test (EUT)

<b>Power Supply Type</b>	12Vdc from adapter
--------------------------	--------------------

### 1.1.4 Accessories

Accessories		
No.	Equipment	Description
1	AC adapter 1	Brand Name: LEI Model Name: ML12-6120100-A1 Power Rating: I/P: 120Vac, 60Hz, 0.3A O/P: 12.0Vdc, 1.0A DC line: 1.7m non-shielded cable w/o core.
2	AC adapter 2	Brand Name: APD Model Name: WA-12M12FU Power Rating: I/P: 120Vac, 60Hz, 0.5A O/P: 12.0Vdc, 1.0A DC line: 1.8m non-shielded cable w/o core.
3	RJ45 cable	0.95m non-shielded cable w/o core.

### 1.1.5 Channel List

802.11 a / HT20 / VHT20		HT40 / VHT40	
Channel	Frequency(MHz)	Channel	Frequency(MHz)
36	5180	38	5190
40	5200	46	5230
44	5220	54	5270
48	5240	62	5310
52	5260	102	5510
56	5280	110	5550
60	5300	134	5670
64	5320	142	5710
100	5500	<b>VHT80</b>	
104	5520	42	5210
108	5540	58	5290
112	5560	106	5530
116	5580	138	5690
136	5680	---	---
140	5700	---	---
144	5720	---	---

Note: The device has disabled the channel 5660MHz by S/W.

### 1.1.6 Test Tool and Duty Cycle

<b>Test Tool</b>	Putty, Version: 0.60.0.0		
<b>Duty Cycle and Duty Factor</b>	<b>Mode</b>	<b>Duty cycle (%)</b>	<b>Duty factor (dB)</b>
	11a	99.73%	0.01
	VHT20	99.14%	0.04
	VHT40	98.83%	0.05
	VHT80	95.21%	0.21

### 1.1.7 Power Setting

For Frequency band 5150-5250 MHz		
Modulation Mode	Test Frequency (MHz)	Power Set
11a	5180	9
11a	5200	9
11a	5240	9
HT20	5180	9
HT20	5200	9
HT20	5240	9
HT40	5190	10
HT40	5230	10
VHT20	5180	9
VHT20	5200	9
VHT20	5240	9
VHT40	5190	10
VHT40	5230	10
VHT80	5210	10



For Frequency band 5250-5350 MHz		
Modulation Mode	Test Frequency (MHz)	Power Set
11a	5260	16
11a	5300	16
11a	5320	16
HT20	5260	16
HT20	5300	16
HT20	5320	16
HT40	5270	16
HT40	5310	13
VHT20	5260	16
VHT20	5300	16
VHT20	5320	16
VHT40	5270	16
VHT40	5310	13
VHT80	5290	11

For Frequency band 5470-5725 MHz		
Modulation Mode	Test Frequency (MHz)	Power Set
11a	5500	15
11a	5580	15
11a	5700	16
HT20	5500	15
HT20	5580	15
HT20	5700	15
HT40	5510	12
HT40	5550	17
HT40	5670	17
VHT20	5500	15
VHT20	5580	15
VHT20	5700	15
VHT40	5510	12
VHT40	5550	17
VHT40	5670	17
VHT80	5530	11

**Channel that extends across the 5.725 GHz boundary**

For Frequency band 5470-5725 MHz		
Modulation Mode	Test Frequency (MHz)	Power Set
11a	5720	16
HT20	5720	16
HT40	5710	17
VHT20	5720	16
VHT40	5710	17
VHT80	5690	17

**1.2 Local Support Equipment List**

Support Equipment List						
No.	Equipment	Brand	Model	S/N	FCC ID	Signal cable / Length (m)
1	Notebook	DELL	E6430	---	DoC	RJ45, 10m non-shielded.

**1.3 Test Setup Chart**

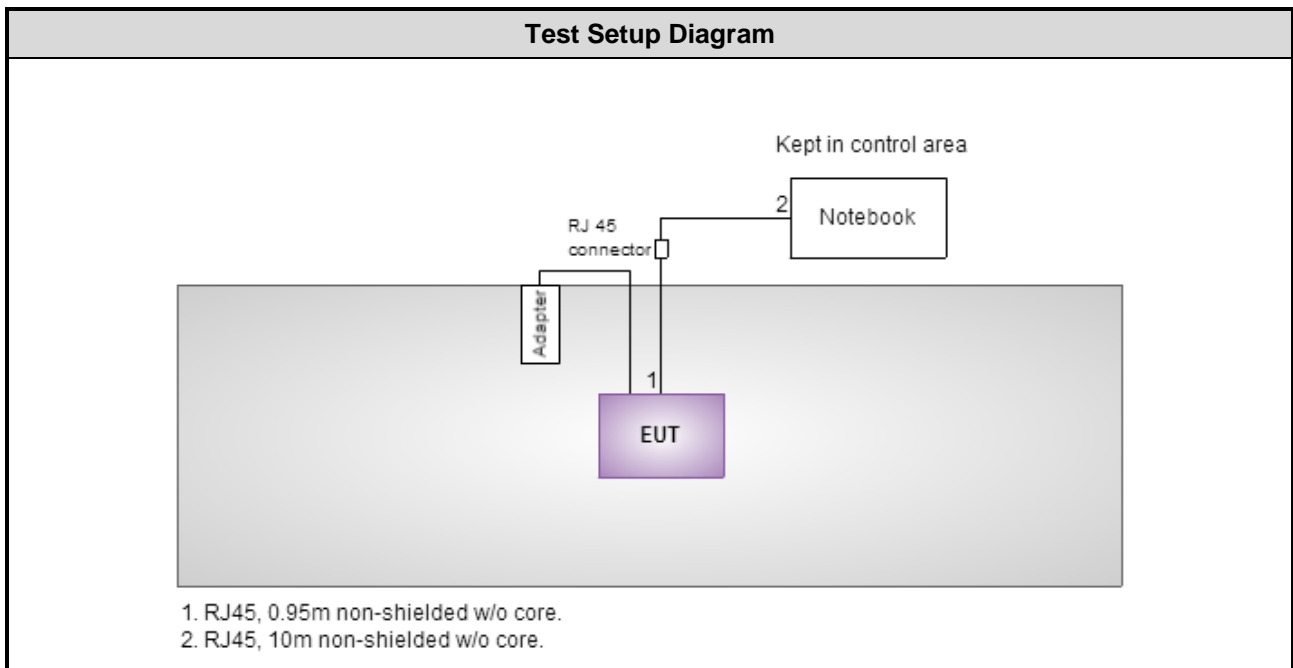

## 1.4 The Equipment List

Test Item	Conducted Emission				
Test Site	Conduction room 1 / (CO01-WS)				
Instrument	Manufacturer	Model No.	Serial No.	Calibration Date	Calibration Until
EMC Receiver	R&S	ESCS 30	100169	Oct. 15, 2013	Oct. 14, 2014
LISN	SCHWARZBECK	Schwarzbeck 8127	8127-667	Nov. 23, 2013	Nov. 22, 2014
LISN (Support Unit)	SCHWARZBECK	Schwarzbeck 8127	8127-666	Dec. 04, 2013	Dec. 03, 2014
RF Cable-CON	Woken	CFD200-NL	CFD200-NL-001	Apr. 23, 2014	Apr. 22, 2015
50 ohm terminal (Support Unit)	NA	50	04	Apr. 18, 2014	Apr. 17, 2015
Note: Calibration Interval of instruments listed above is one year.					

Test Item	Radiated Emission				
Test Site	966 chamber1 / (03CH01-WS)				
Instrument	Manufacturer	Model No.	Serial No.	Calibration Date	Calibration Until
Spectrum Analyzer	R&S	FSV40	101498	Jan. 25, 2014	Jan. 24, 2015
Receiver	R&S	ESR3	101658	Jan. 10, 2014	Jan. 09, 2015
Bilog Antenna	SCHWARZBECK	VULB9168	VULB9168-522	Jan. 02, 2014	Jan. 01, 2015
Horn Antenna 1G-18G	SCHWARZBECK	BBHA 9120 D	BBHA 9120 D 1096	Feb. 13, 2014	Feb. 12, 2015
Horn Antenna 18G-40G	SCHWARZBECK	BBHA 9170	BBHA 9170517	Dec. 27, 2013	Dec. 26, 2014
Preamplifier	Burgeon	BPA-530	SN:100219	Nov. 28, 2013	Nov. 27, 2014
Preamplifier	Agilent	83017A	MY39501308	Dec. 16, 2013	Dec. 15, 2014
Preamplifier	WM	TF-130N-R1	923365	Oct. 23, 2013	Oct. 22, 2014
RF Cable	HUBER+SUHNER	SUCOFLEX104	MY16014/4	Dec. 16, 2013	Dec. 15, 2014
RF Cable	HUBER+SUHNER	SUCOFLEX104	MY16019/4	Dec. 16, 2013	Dec. 15, 2014
RF Cable	HUBER+SUHNER	SUCOFLEX104	MY16139/4	Dec. 16, 2013	Dec. 15, 2014
LF cable 3M	Woken	CFD400NL-LW	CFD400NL-001	Dec. 16, 2013	Dec. 15, 2014
LF cable 10M	Woken	CFD400NL-LW	CFD400NL-002	Dec. 16, 2013	Dec. 15, 2014
Note: Calibration Interval of instruments listed above is one year.					

Loop Antenna	R&S	HFH2-Z2	100330	Nov. 15, 2012	Nov. 14, 2014
Note: Calibration Interval of instruments listed above is two year.					

<b>Test Item</b>	RF Conducted				
<b>Test Site</b>	(TH01-WS)				
<b>Instrument</b>	<b>Manufacturer</b>	<b>Model No.</b>	<b>Serial No.</b>	<b>Calibration Date</b>	<b>Calibration Until</b>
Spectrum Analyzer	R&S	FSV40	101063	Feb. 17, 2014	Feb. 16, 2015
TEMP&HUMIDITY CHAMBER	GIANT FORCE	GCT-225-40-SP-SD	MAF1212-002	Dec. 11, 2013	Dec. 10, 2014
Power Meter	Anritsu	ML2495A	1241002	Oct. 24, 2013	Oct. 23, 2014
Power Sensor	Anritsu	MA2411B	1207366	Oct. 24, 2013	Oct. 23, 2014
Note: Calibration Interval of instruments listed above is one year.					

## 1.5 Testing Applied Standards

According to the specification of EUT, the EUT must comply with following standards and KDB documents.

47 CFR FCC Part 15.407

ANSI C63.10-2009

FCC KDB 789033 D01 General UNII Test Procedures Old Rules v01r04

FCC KDB 644545 D01 Guidance for IEEE 802 11ac v01r02

FCC KDB 644545 D02 Alternative Guidance for 802 11ac v01

FCC KDB 662911 D01 Multiple Transmitter Output v02r01

Note: The EUT has been tested and complied with FCC part 15B requirement. FCC Part 15B test results are issued to another report.

## 1.6 Measurement Uncertainty

ISO/IEC 17025 requires that an estimate of the measurement uncertainties associated with the emissions test results be included in the report. The measurement uncertainties given below are based on a 95% confidence level (based on a coverage factor ( $k=2$ ))

Measurement Uncertainty	
Parameters	Uncertainty
Bandwidth	$\pm 34.134$ Hz
Conducted power	$\pm 0.808$ dB
Frequency error	$\pm 34.134$ Hz
Temperature	$\pm 0.6$ °C
Conducted emission	$\pm 2.670$ dB
AC conducted emission	$\pm 2.92$ dB
Radiated emission $\leq 1$ GHz	$\pm 3.26$ dB
Radiated emission $> 1$ GHz	$\pm 4.94$ dB

## 2 Test Configuration

### 2.1 Testing Condition

Test Item	Test Site	Ambient Condition	Tested By
AC Conduction	CO01-WS	22°C / 67%	Peter Lin
Radiated Emissions	03CH01-WS	23-25°C / 64-65%	Haru Yang
RF Conducted	TH01-WS	21°C / 67%	Brad Wu

- FCC site registration No.: 657002
- IC site registration No.: 10807A-1

## 2.2 The Worst Test Modes and Channel Details

Test item	Modulation Mode	Test Frequency (MHz)	Data Rate (Mbps) / MCS	Test Configuration
Conducted Emissions	VHT40	5510	MCS 0	---
Radiated Emissions $\leq 1$ GHz	VHT40	5510	MCS 0	---
RF Output Power	11a	5180 / 5200 / 5240 / 5260 / 5300 5320 / 5500 / 5580 / 5700 / 5720	6 Mbps	---
	HT20	5180 / 5200 / 5240 / 5260 / 5300 5320 / 5500 / 5580 / 5700 / 5720	MCS 0	---
	HT40	5190 / 5230 / 5270 / 5310 / 5510 5550 / 5670 / 5710	MCS 0	---
	VHT20	5180 / 5200 / 5240 / 5260 / 5300 5320 / 5500 / 5580 / 5700 / 5720	MCS 0	---
	VHT40	5190 / 5230 / 5270 / 5310 / 5510 5550 / 5670 / 5710	MCS 0	---
	VHT80	5210 / 5290 / 5530 / 5690	MCS 0	---
Radiated Emissions $> 1$ GHz Emission Bandwidth Peak Power Spectral Density	11a	5180 / 5200 / 5240 / 5260 / 5300 5320 / 5500 / 5580 / 5700 / 5720	6 Mbps	---
	VHT20	5180 / 5200 / 5240 / 5260 / 5300 5320 / 5500 / 5580 / 5700 / 5720	MCS 0	---
	VHT40	5190 / 5230 / 5270 / 5310 / 5510 5550 / 5670 / 5710	MCS 0	---
	VHT80	5210 / 5290 / 5530 / 5690	MCS 0	---
Peak Excursion	11a	5180 / 5300 / 5700	6 Mbps	---
	VHT20	5200 / 5260 / 5580	MCS 0	---
	VHT40	5190 / 5270 / 5710	MCS 0	---
	VHT80	5210 / 5290 / 5690	MCS 0	---
Frequency Stability	Un-modulation	5320	---	---
<b>NOTE:</b>				
1) Adapter 1 and Adapter 2 had been pretested and found that <b>Adapter 1</b> was the worst case and was selected for final testing ( <b>Adapter 1: LEI adapter</b> ; Adapter 2: APD adapter).				

## 3 Transmitter Test Results

### 3.1 Conducted Emissions

#### 3.1.1 Limit of Conducted Emissions

Conducted Emissions Limit		
Frequency Emission (MHz)	Quasi-Peak	Average
0.15-0.5	66 - 56 *	56 - 46 *
0.5-5	56	46
5-30	60	50

Note 1: \* Decreases with the logarithm of the frequency.

#### 3.1.2 Test Procedures

1. The device is placed on a test table, raised 80 cm above the reference ground plane. The vertical conducting plane is located 40 cm to the rear of the device.
2. The device is connected to line impedance stabilization network (LISN) and other accessories are connected to other LISN. Measured levels of AC power line conducted emission are across the 50  $\Omega$  LISN port.
3. AC conducted emission measurements is made over frequency range from 150 kHz to 30 MHz.
4. This measurement was performed with AC 120V/60Hz

#### 3.1.3 Test Setup

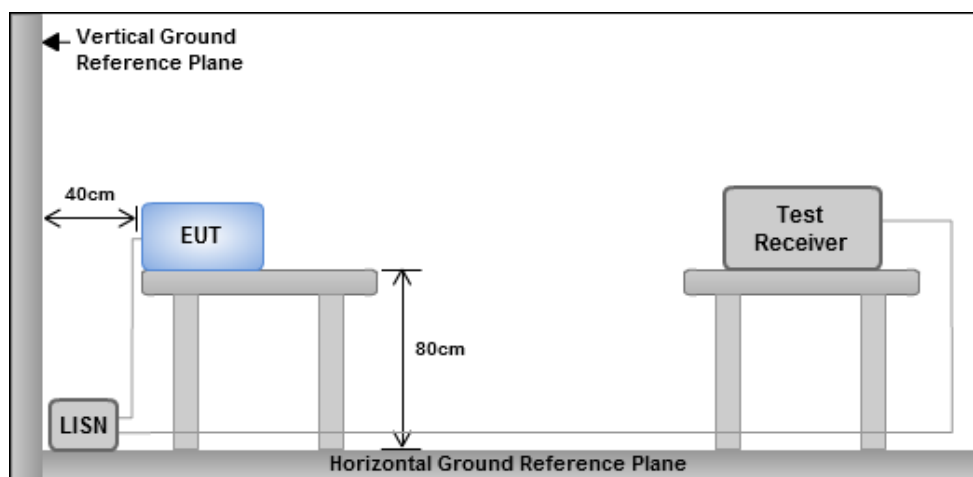

- Note: 1. Support units were connected to second LISN.  
 2. Both of LISNs (AMN) are 80 cm from EUT and at least 80 cm from other units and other metal planes

### 3.1.4 Test Result of Conducted Emissions

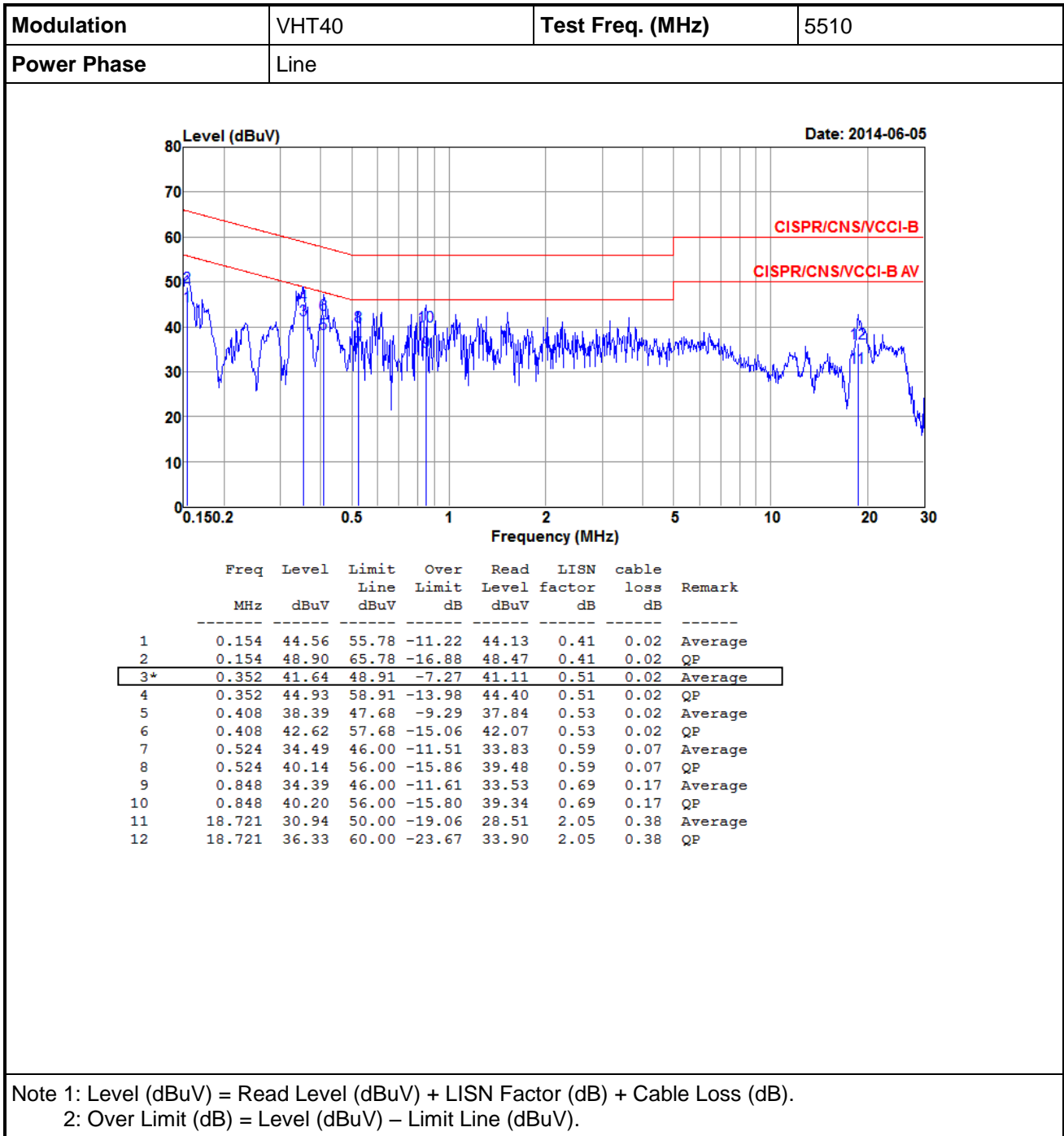



<b>Modulation</b>	VHT40	<b>Test Freq. (MHz)</b>	5510
<b>Power Phase</b>	Neutral		

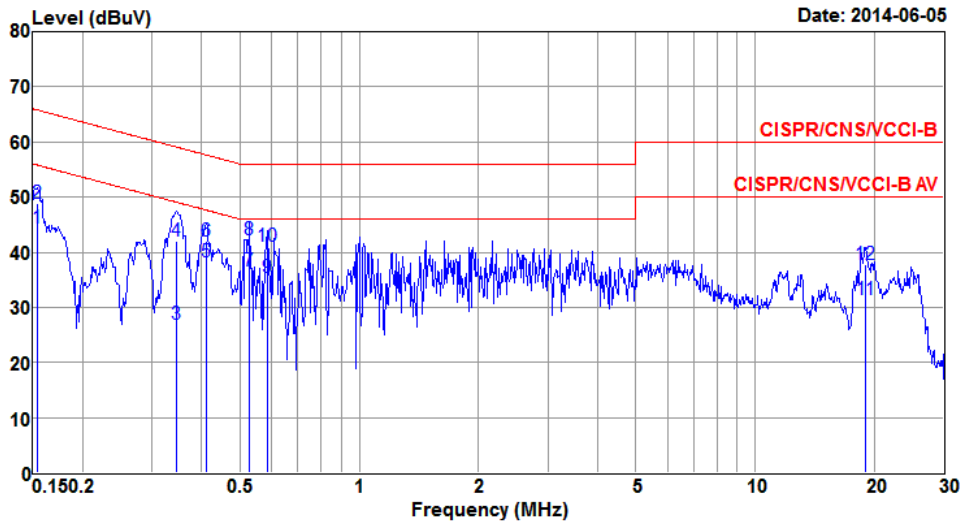

	Freq	Level	Limit	Over	Read	LISN	cable	Remark
	MHz	dBuV	Line	Limit	Level	factor	loss	
			dBuV	dB	dBuV	dB	dB	
1	0.154	44.48	55.78	-11.30	43.97	0.49	0.02	Average
2	0.154	48.92	65.78	-16.86	48.41	0.49	0.02	QP
3	0.345	27.00	49.09	-22.09	26.39	0.59	0.02	Average
4	0.345	41.95	59.09	-17.14	41.34	0.59	0.02	QP
5*	0.410	38.23	47.64	-9.41	37.59	0.62	0.02	Average
6	0.410	42.05	57.64	-15.59	41.41	0.62	0.02	QP
7	0.529	36.51	46.00	-9.49	35.77	0.67	0.07	Average
8	0.529	42.25	56.00	-13.75	41.51	0.67	0.07	QP
9	0.589	35.31	46.00	-10.69	34.53	0.69	0.09	Average
10	0.589	41.16	56.00	-14.84	40.38	0.69	0.09	QP
11	19.021	31.41	50.00	-18.59	28.49	2.54	0.38	Average
12	19.021	37.67	60.00	-22.33	34.75	2.54	0.38	QP

Note 1: Level (dBuV) = Read Level (dBuV) + LISN Factor (dB) + Cable Loss (dB).  
 2: Over Limit (dB) = Level (dBuV) – Limit Line (dBuV).

## 3.2 Emission Bandwidth

### 3.2.1 Test Procedures

1. Set RBW = approximately 1% of the emission bandwidth.
2. Set the VBW > RBW, Detector = Peak.
3. Trace mode = max hold.
4. Measure the maximum width of the emission that is 26 dB down from the peak of the emission.

### 3.2.2 Test Setup

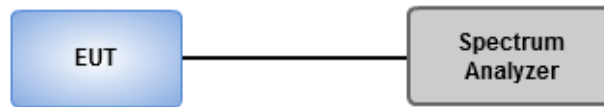

### 3.2.3 Test Result of Emission Bandwidth

Emission Bandwidth												
Mode	N <sub>TX</sub>	Freq. (MHz)	26dB Bandwidth (MHz)				99% Bandwidth (MHz)				Power Limit (dBm)	
			Chain 0	Chain 1	Chain 2	Chain 3	Chain 0	Chain 1	Chain 2	Chain 3	26dB BW	99%OBW
11a	4	5180	22.96	23.48	23.30	23.42	16.90	17.00	16.90	16.90	17.00	16.28
11a	4	5200	22.90	23.59	23.25	23.48	16.90	17.04	16.90	16.90	17.00	16.28
11a	4	5240	22.96	23.65	23.42	23.48	16.90	17.04	16.90	16.90	17.00	16.28
VHT20	4	5180	24.81	25.22	24.58	24.00	18.23	18.27	18.09	17.91	17.00	16.53
VHT20	4	5200	25.10	25.22	24.41	23.83	18.23	18.27	18.09	17.91	17.00	16.53
VHT20	4	5240	24.99	25.22	24.46	24.06	18.20	18.27	18.09	17.95	17.00	16.54
VHT40	4	5190	44.41	44.17	44.17	43.59	37.25	36.79	36.92	36.73	17.00	17.00
VHT40	4	5230	44.52	43.83	44.52	43.71	37.12	36.92	36.86	36.73	17.00	17.00
VHT80	4	5210	83.71	80.00	82.09	82.09	75.41	75.16	75.28	75.41	17.00	17.00
11a	4	5260	22.96	23.59	22.96	23.36	16.90	17.00	16.90	16.90	24.00	23.28
11a	4	5300	22.90	23.59	23.07	23.48	16.90	17.00	16.90	16.90	24.00	23.28
11a	4	5320	22.84	23.48	22.84	23.59	16.93	16.97	16.90	16.90	24.00	23.28
VHT20	4	5260	24.87	25.16	24.23	23.83	18.20	18.23	18.09	17.91	24.00	23.53
VHT20	4	5300	24.81	25.10	24.17	23.83	18.20	18.27	18.09	17.91	24.00	23.53
VHT20	4	5320	24.75	25.10	24.41	23.71	18.20	18.27	18.09	17.91	24.00	23.53
VHT40	4	5270	44.41	44.17	43.94	43.59	37.12	36.92	36.99	36.79	24.00	24.00
VHT40	4	5310	44.52	43.59	44.17	43.83	37.19	36.86	36.92	36.73	24.00	24.00
VHT80	4	5290	83.25	80.00	82.32	81.62	75.28	74.91	75.28	75.41	24.00	24.00
11a	4	5500	22.96	23.65	22.90	23.65	16.90	17.08	16.90	16.93	24.00	23.28
11a	4	5580	22.96	23.77	22.96	23.59	16.90	17.04	16.93	16.93	24.00	23.28
11a	4	5700	23.25	23.71	22.96	23.48	16.93	17.04	16.90	16.93	24.00	23.28
VHT20	4	5500	24.81	25.04	24.35	23.83	18.16	18.27	18.09	17.95	24.00	23.54
VHT20	4	5580	24.81	25.04	24.58	23.88	18.23	18.31	18.13	17.95	24.00	23.54
VHT20	4	5700	24.99	24.99	24.58	23.94	18.27	18.23	18.13	17.95	24.00	23.54
VHT40	4	5510	44.64	44.06	44.29	43.83	37.25	36.86	36.92	36.79	24.00	24.00
VHT40	4	5550	44.29	44.64	44.64	44.17	37.25	36.74	36.92	36.79	24.00	24.00
VHT40	4	5670	44.41	44.99	44.64	44.29	37.19	36.79	36.86	36.79	24.00	24.00
VHT80	4	5530	83.48	80.46	82.78	82.78	75.04	75.04	75.28	75.28	24.00	24.00

### Worst Plots

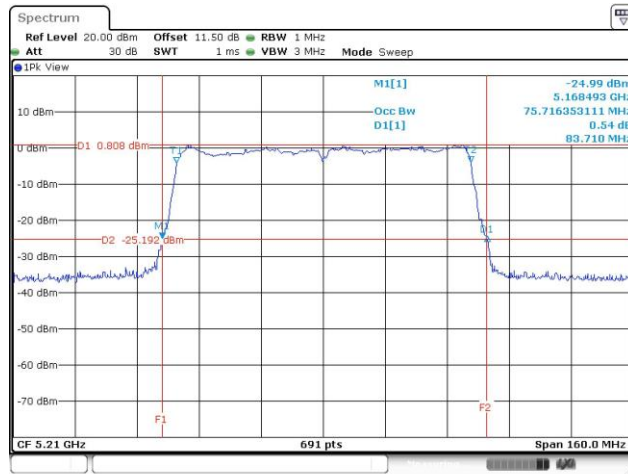

**Channel that extends across the 5.725 GHz boundary**

UNII Emission Bandwidth Result ( Within 5470-5725MHz band )												
Mode	N <sub>TX</sub>	Freq. (MHz)	26dB Bandwidth (MHz)				99% Bandwidth (MHz)				Power Limit (dBm)	
			Chain 0	Chain 1	Chain 2	Chain 3	Chain 0	Chain 1	Chain 2	Chain 3	26dB BW	99% BW
11a	4	5720	16.88	16.57	16.63	16.45	13.64	13.64	13.53	13.53	23.16	22.31
VHT20	4	5720	17.62	17.06	17.31	17.80	14.29	14.36	14.29	14.07	23.32	22.48
VHT40	4	5710	37.33	37.54	37.23	37.03	33.54	33.34	33.41	33.28	24.00	24.00
VHT80	4	5690	88.48	88.70	88.26	78.70	72.45	72.21	72.45	72.33	24.00	24.00

UNII Emission Bandwidth Result ( Extends across 5725MHz band )												
Mode	N <sub>TX</sub>	Freq. (MHz)	26dB Bandwidth (MHz)				99% Bandwidth (MHz)				Power Limit (dBm)	
			Chain 0	Chain 1	Chain 2	Chain 3	Chain 0	Chain 1	Chain 2	Chain 3	26dB BW	99% BW
11a	4	5720	6.83	7.48	6.33	7.20	4.73	5.02	4.65	5.27	19.01	17.67
VHT20	4	5720	7.52	7.26	7.09	7.02	5.28	5.31	5.04	5.11	19.46	18.02
VHT40	4	5710	7.30	7.85	9.46	7.07	5.56	5.83	5.92	5.47	19.49	18.38
VHT80	4	5690	12.22	11.83	12.35	12.52	5.96	5.77	5.99	6.14	21.73	18.61

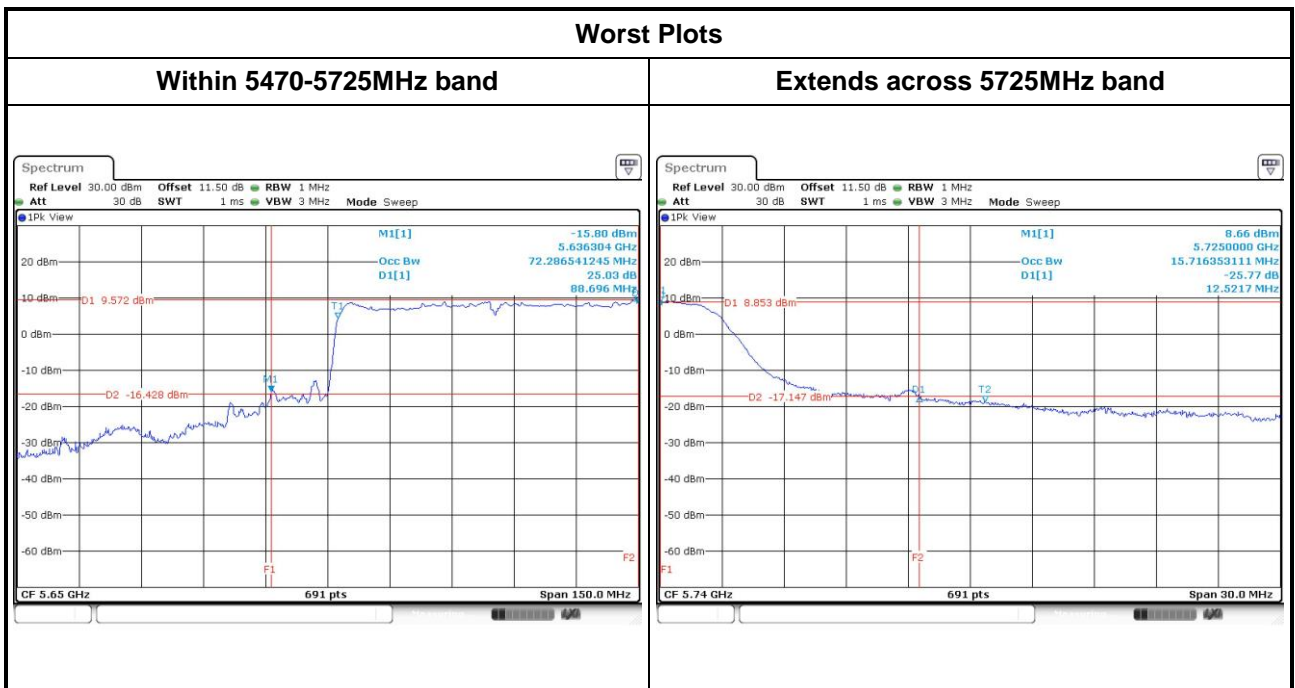

### 3.3 RF Output Power

#### 3.3.1 Limit of RF Output Power

Frequency Band (GHz)		Limit for FCC 15.407
<input checked="" type="checkbox"/>	5.15~5.25	50mW or 4dBm+10 log B
<input checked="" type="checkbox"/>	5.25~5.35	250mW or 11dBm+10 log B
<input checked="" type="checkbox"/>	5.47~5.725	250mW or 11dBm+10 log B

Note: "B" is the 26dB emission bandwidth in MHz.

#### 3.3.2 Test Procedures

- Power meter ( For channel that does not extends across the 5.725 GHz boundary )
  - Measurements is performed using a wideband gated RF power meter provided that the gate parameters are adjusted such that the power is measured only when the EUT is transmitting at its maximum power control level. Since the measurement is made only during the ON time of the transmitter, no duty cycle correction factor is required
- Spectrum analyzer ( For channel that extends across the 5.725 GHz boundary )
  1. Set RBW=1MHz, VBW=3MHz , Sweep time= Auto, Detector = RMS
  2. Trace average at least 100 traces in power averaging mode
  3. Compute power by integrating the spectrum across the 26 dB EBW

#### 3.3.3 Test Setup

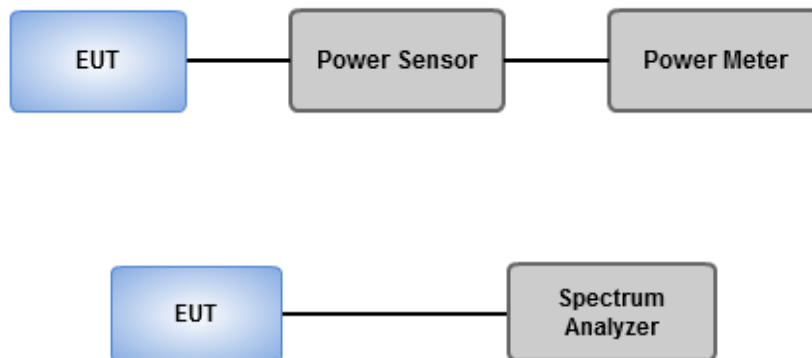

### 3.3.4 Test Result of Maximum Conducted Output Power

Mode	N <sub>TX</sub>	Freq. (MHz)	Conducted Power (dBm)				Total Power (mW)	Total Power (dBm)	Limit (dBm)
			Chain 0	Chain 1	Chain 2	Chain 3			
11a	4	5180	8.26	8.73	7.87	8.51	27.383	14.37	17.00
11a	4	5200	8.26	8.56	7.86	8.71	27.416	14.38	17.00
11a	4	5240	8.48	8.49	8.52	8.11	27.694	14.42	17.00
HT20	4	5180	8.45	8.63	7.54	8.06	26.366	14.21	17.00
HT20	4	5200	8.49	8.92	7.96	8.27	27.827	14.44	17.00
HT20	4	5240	8.53	8.48	8.52	8.61	28.549	14.56	17.00
HT40	4	5190	10.12	10.34	9.58	10.25	40.765	16.10	17.00
HT40	4	5230	9.92	10.24	9.83	10.15	40.353	16.06	17.00
VHT20	4	5180	8.59	8.72	7.66	8.12	26.996	14.31	17.00
VHT20	4	5200	8.58	9.01	8.11	8.41	28.578	14.56	17.00
VHT20	4	5240	8.65	8.61	8.63	8.75	29.383	14.68	17.00
VHT40	4	5190	10.24	10.45	9.66	10.36	41.771	16.21	17.00
VHT40	4	5230	10.09	10.36	9.98	10.21	41.523	16.18	17.00
VHT80	4	5210	9.72	10.05	10.06	10.15	39.982	16.02	17.00
11a	4	5260	16.28	16.83	16.23	16.51	177.404	22.49	24.00
11a	4	5300	16.26	16.87	16.26	16.58	178.673	22.52	24.00
11a	4	5320	15.99	16.85	16.26	16.36	173.655	22.40	24.00
HT20	4	5260	16.02	16.45	16.24	16.71	173.106	22.38	24.00
HT20	4	5300	15.82	16.49	16.12	16.75	171.001	22.33	24.00
HT20	4	5320	16.25	16.44	16.18	16.52	172.595	22.37	24.00
HT40	4	5270	16.36	16.94	16.85	16.82	189.184	22.77	24.00
HT40	4	5310	13.54	14.08	13.62	14.05	96.604	19.85	24.00
VHT20	4	5260	16.19	16.56	16.36	16.87	178.773	22.52	24.00
VHT20	4	5300	15.99	16.61	16.20	16.84	175.526	22.44	24.00
VHT20	4	5320	16.38	16.58	16.29	16.67	177.961	22.50	24.00
VHT40	4	5270	16.68	17.11	17.19	17.03	200.789	23.03	24.00
VHT40	4	5310	13.61	14.21	13.77	14.12	98.971	19.96	24.00
VHT80	4	5290	11.11	11.50	11.18	11.10	53.042	17.25	24.00

Mode	N <sub>TX</sub>	Freq. (MHz)	Conducted Power (dBm)				Total Power (mW)	Total Power (dBm)	Limit (dBm)
			Chain 0	Chain 1	Chain 2	Chain 3			
11a	4	5500	14.92	15.45	15.36	15.56	136.452	21.35	24.00
11a	4	5580	15.44	16.17	15.68	15.73	150.788	21.78	24.00
11a	4	5700	15.96	17.15	16.48	16.14	176.904	22.48	24.00
HT20	4	5500	15.21	15.53	15.49	15.72	141.641	21.51	24.00
HT20	4	5580	15.56	16.14	15.63	16.15	154.859	21.90	24.00
HT20	4	5700	14.98	15.69	15.43	15.21	136.649	21.36	24.00
HT40	4	5510	11.51	12.54	11.38	12.65	64.253	18.08	24.00
HT40	4	5550	17.13	17.56	17.45	17.68	222.862	23.48	24.00
HT40	4	5670	17.31	17.15	17.08	17.54	213.512	23.29	24.00
VHT20	4	5500	15.29	15.65	15.66	15.88	146.073	21.65	24.00
VHT20	4	5580	15.67	16.27	15.72	16.22	158.466	22.00	24.00
VHT20	4	5700	15.09	15.81	15.51	15.33	140.074	21.46	24.00
VHT40	4	5510	11.60	12.69	11.49	12.81	66.224	18.21	24.00
VHT40	4	5550	17.25	17.71	17.59	17.81	229.915	23.62	24.00
VHT40	4	5670	17.45	17.29	17.21	17.74	221.201	23.45	24.00
VHT80	4	5530	10.63	11.53	10.66	11.21	50.639	17.04	24.00



**Channel that extends across the 5.725 GHz boundary**

Maximum Conducted Output Power (Within 5470-5725MHz band)									
RF Output Power (dBm)									
Mode	N <sub>TX</sub>	Freq. (MHz)	Chain 0	Chain 1	Chain 2	Chain 3	Total Power (mW)	Total Power (dBm)	Limit
11a	4	5720	15.04	15.76	15.22	15.50	138.333	21.41	23.16
HT20	4	5720	15.08	16.08	15.35	15.57	143.096	21.56	23.32
HT40	4	5710	17.44	17.93	17.44	17.24	225.978	23.54	24.00
VHT20	4	5720	15.19	15.93	15.40	15.66	143.698	21.57	23.32
VHT40	4	5710	17.13	18.08	17.67	17.51	230.753	23.63	24.00
VHT80	4	5690	17.12	17.56	16.72	17.48	211.660	23.26	24.00

Maximum Conducted Output Power (Extends across 5725MHz band)									
RF Output Power (dBm)									
Mode	N <sub>TX</sub>	Freq. (MHz)	Chain 0	Chain 1	Chain 2	Chain 3	Total Power (mW)	Total Power (dBm)	Limit
11a	4	5720	9.33	10.03	9.51	9.49	36.465	15.62	19.01
HT20	4	5720	9.66	10.79	10.19	10.07	41.852	16.22	19.46
HT40	4	5710	6.78	8.09	7.61	7.89	23.125	13.64	19.49
VHT20	4	5720	9.81	10.71	10.23	10.14	42.219	16.26	19.46
VHT40	4	5710	6.83	8.23	7.50	7.91	23.276	13.67	19.49
VHT80	4	5690	2.93	4.31	3.31	4.42	9.578	9.81	21.73

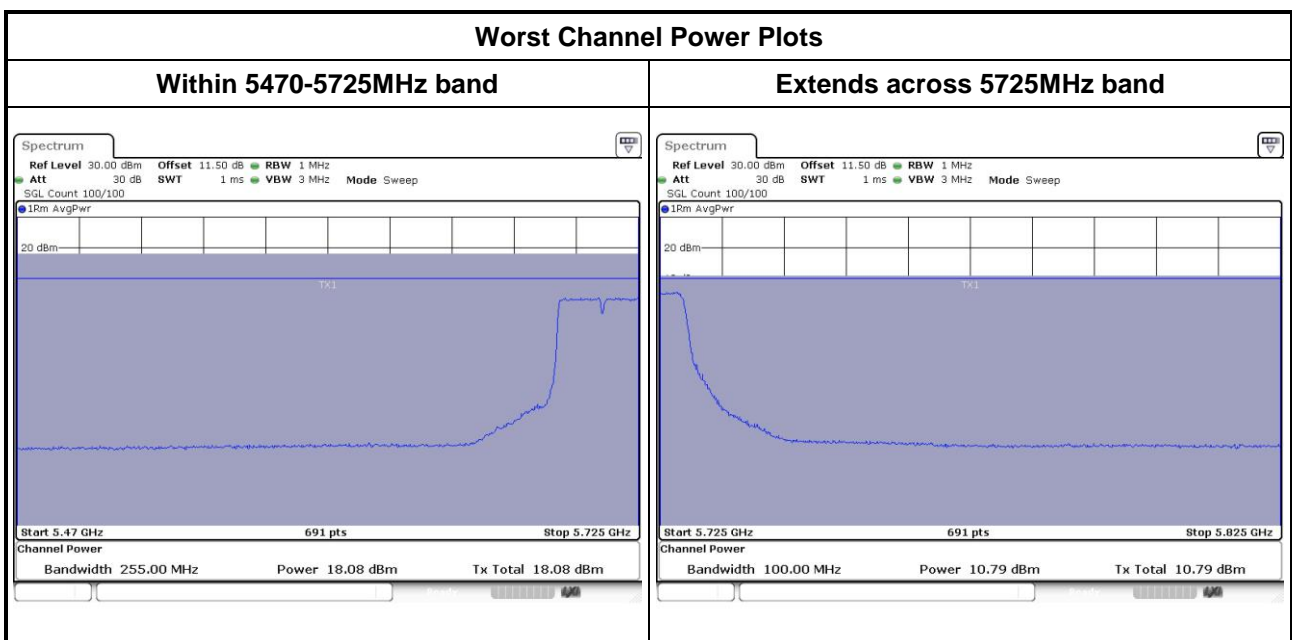

Note: Above plots are without duty factor.

## 3.4 Peak Power Spectral Density

### 3.4.1 Limit of Peak Power Spectral Density

	Frequency Band (GHz)	Limit (dBm)
<input checked="" type="checkbox"/>	5.15~5.25	4
<input checked="" type="checkbox"/>	5.25~5.35	11
<input checked="" type="checkbox"/>	5.47~5.725	11

### 3.4.2 Test Procedures

- Method SA-1 (for 11a, ac VHT20/40)
  1. Set RBW = 1 MHz, VBW = 3 MHz, Sweep time = auto, Detector = RMS.
  2. Trace average 100 traces.
  3. Use the peak marker function to determine the maximum amplitude level.
- Method SA-2
  1. Set RBW = 1 MHz, VBW = 3 MHz, Detector = RMS.
  2. Set sweep time  $\geq 10 * (\text{number of points in sweep}) * (\text{symbol period of the transmitted signal})$ .
  3. Perform a single sweep.
  4. Use the peak marker function to determine the maximum amplitude level.
- Method SA-2 Alternative (for 11 ac VHT80)
  1. Set RBW = 1 MHz, VBW = 3 MHz, Detector = RMS.
  2. Set sweep time  $\geq 10 * (\text{number of points in sweep}) * (\text{total on/off period of the transmitted signal})$ .
  3. Perform a single sweep.
  4. Use the peak marker function to determine the maximum amplitude level.
  5. Add  $10 \log(1/x)$ , where x is the duty cycle.

### 3.4.3 Test Setup

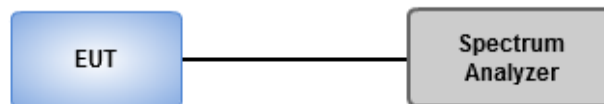

### 3.4.4 Test Result of Peak Power Spectral Density

Condition			Peak Power Spectral Density (dBm)			
Mode	N <sub>TX</sub>	Freq. (MHz)	PPSD w/o D.F (dBm)	Duty Factor (dB)	PPSD with D.F (dBm)	PPSD Limit (dBm)
11a	4	5180	1.10	0.00	1.10	3.98
11a	4	5200	1.49	0.00	1.49	3.98
11a	4	5240	1.45	0.00	1.45	3.98
VHT20	4	5180	1.04	0.00	1.04	3.98
VHT20	4	5200	1.64	0.00	1.64	3.98
VHT20	4	5240	1.85	0.00	1.85	3.98
VHT40	4	5190	0.16	0.00	0.16	3.98
VHT40	4	5230	0.12	0.00	0.12	3.98
VHT80	4	5210	-2.69	0.21	-2.48	3.98
11a	4	5260	8.90	0.00	8.90	10.98
11a	4	5300	8.88	0.00	8.88	10.98
11a	4	5320	8.83	0.00	8.83	10.98
VHT20	4	5260	8.88	0.00	8.88	10.98
VHT20	4	5300	8.80	0.00	8.80	10.98
VHT20	4	5320	8.88	0.00	8.88	10.98
VHT40	4	5270	6.85	0.00	6.85	10.98
VHT40	4	5310	3.63	0.00	3.63	10.98
VHT80	4	5290	-1.37	0.21	-1.16	10.98
11a	4	5500	8.60	0.00	8.60	10.98
11a	4	5580	8.16	0.00	8.16	10.98
11a	4	5700	8.87	0.00	8.87	10.98
11a	4	5720	8.78	0.00	8.78	10.98
VHT20	4	5500	8.58	0.00	8.58	10.98
VHT20	4	5580	8.58	0.00	8.58	10.98
VHT20	4	5700	8.51	0.00	8.51	10.98
VHT20	4	5720	8.74	0.00	8.74	10.98
VHT40	4	5510	2.10	0.00	2.10	10.98
VHT40	4	5550	7.41	0.00	7.41	10.98
VHT40	4	5670	7.35	0.00	7.35	10.98
VHT40	4	5710	7.69	0.00	7.69	10.98
VHT80	4	5530	-2.04	0.21	-1.83	10.98
VHT80	4	5690	4.78	0.21	4.99	10.98

**Note:**

1. D.F is duty factor.
2. Test result is bin-by-bin summing measured value of each TX port.
3. Directional gain =  $0 + 10 \cdot \log(4/1) = 6.02 \text{ dBi} > 6 \text{ dBi}$ .  
Limit shall be reduced to  $4 \text{ dBm} - (6.02 \text{ dBi} - 6 \text{ dBi}) = 3.98 \text{ dBm}$ .  
Limit shall be reduced to  $11 \text{ dBm} - (6.02 \text{ dBi} - 6 \text{ dBi}) = 10.98 \text{ dBm}$ .

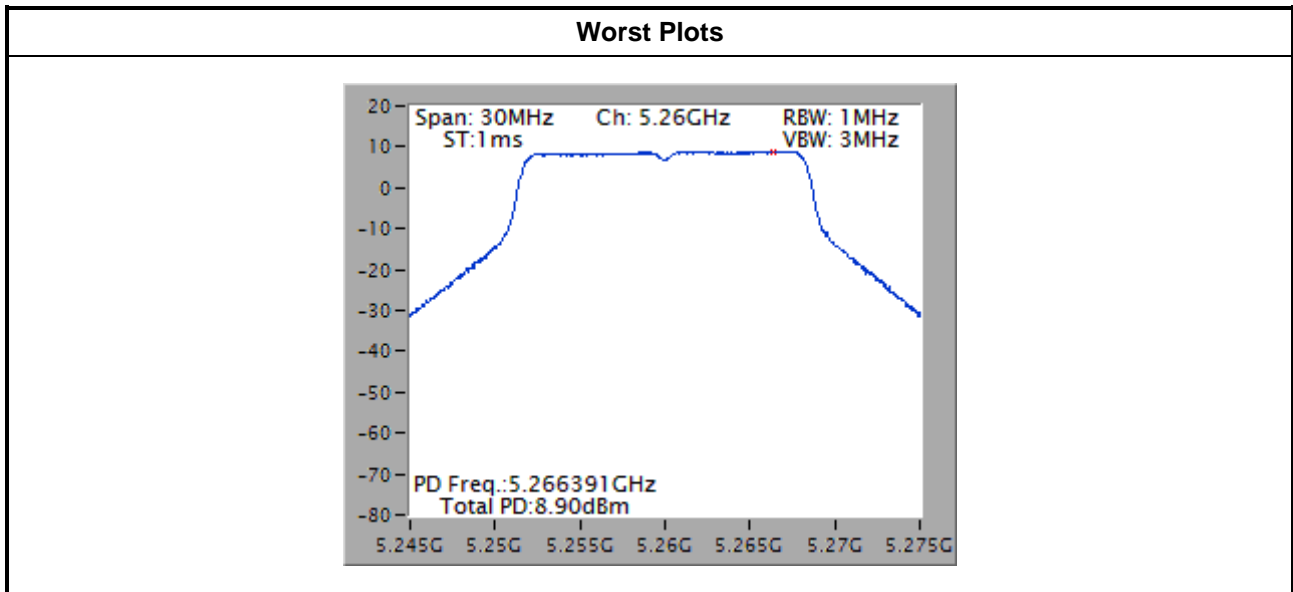

Note: Power density plot without duty factor.

## 3.5 Peak Excursion

### 3.5.1 Peak Excursion Limit

Peak excursion of the modulation envelope shall not exceed 13 dB across any 1 MHz bandwidth.

### 3.5.2 Test Procedures

1. Set RBW = 1 MHz, VBW = 3 MHz, Detector = peak.
2. Trace mode = max-hold. Allow the sweeps to continue until the trace stabilizes.
3. Use the peak search function to find the peak of the spectrum.
4. Use the procedure of section 3.4.2 to measure the PPSD.
5. Compute the ratio of the maximum of the peak-max-hold spectrum to the PPSD

### 3.5.3 Test Setup

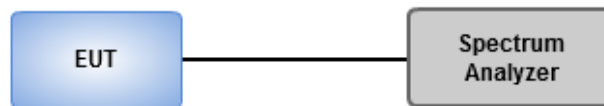

### 3.5.4 Test Result of Peak Excursion

Frequency band 5150-5250 MHz							
Mode	Modulation Mode	N <sub>TX</sub>	Freq. (MHz)	Measured Value(dB)	Duty Factor (dB)	Peak Excursion (dB)	Limit
11a	BPSK	4	5180	7.48	0.00	7.48	13
11a	QPSK	4	5180	7.8	0.00	7.80	13
11a	16QAM	4	5180	8.54	0.00	8.54	13
11a	64QAM	4	5180	9.81	0.18	9.63	13
VHT20	BPSK	4	5200	8.26	0.00	8.26	13
VHT20	QPSK	4	5200	8.55	0.00	8.55	13
VHT20	16QAM	4	5200	8.57	0.10	8.47	13
VHT20	64QAM	4	5200	9.33	0.27	9.06	13
VHT20	256QAM	4	5200	10.13	0.51	9.62	13
VHT40	BPSK	4	5190	8.13	0.00	8.13	13
VHT40	QPSK	4	5190	8.48	0.15	8.33	13
VHT40	16QAM	4	5190	9.43	0.25	9.18	13
VHT40	64QAM	4	5190	11.11	0.56	10.55	13
VHT40	256QAM	4	5190	9	0.64	8.36	13
VHT80	BPSK	4	5210	10.53	0.21	10.32	13
VHT80	QPSK	4	5210	8.42	0.37	8.05	13
VHT80	16QAM	4	5210	9.06	0.38	8.68	13
VHT80	64QAM	4	5210	8.93	1.08	7.85	13
VHT80	256QAM	4	5210	9.51	1.66	7.85	13

Note: Measured value = Peak-max-hold spectrum to the maximum of the average spectrum for continuous transmission. Since the duty cycle is < 98 %, duty factor is required to average spectrum  
Peak excursion = Measured value – duty factor

Frequency band 5250-5350 MHz							
Mode	Modulation Mode	N <sub>TX</sub>	Freq. (MHz)	Measured Value(dB)	Duty Factor (dB)	Peak Excursion (dB)	Limit
11a	BPSK	4	5300	7.54	0.00	7.54	13
11a	QPSK	4	5300	7.95	0.00	7.95	13
11a	16QAM	4	5300	8.51	0.00	8.51	13
11a	64QAM	4	5300	9.77	0.18	9.59	13
VHT20	BPSK	4	5260	8.88	0.00	8.88	13
VHT20	QPSK	4	5260	7.86	0.00	7.86	13
VHT20	16QAM	4	5260	8.62	0.10	8.52	13
VHT20	64QAM	4	5260	9.7	0.27	9.43	13
VHT20	256QAM	4	5260	9.95	0.51	9.44	13
VHT40	BPSK	4	5270	8.19	0.00	8.19	13
VHT40	QPSK	4	5270	8.06	0.15	7.91	13
VHT40	16QAM	4	5270	9.04	0.25	8.79	13
VHT40	64QAM	4	5270	10.71	0.56	10.15	13
VHT40	256QAM	4	5270	9.31	0.64	8.67	13
VHT80	BPSK	4	5290	8.13	0.21	7.92	13
VHT80	QPSK	4	5290	7.85	0.37	7.48	13
VHT80	16QAM	4	5290	8.83	0.38	8.45	13
VHT80	64QAM	4	5290	8.4	1.08	7.32	13
VHT80	256QAM	4	5290	9.41	1.66	7.75	13

Note: Measured value = Peak-max-hold spectrum to the maximum of the average spectrum for continuous transmission. Since the duty cycle is < 98 %, duty factor is required to average spectrum  
Peak exclusion = Measured value – duty factor

Frequency band 5470-5725 MHz							
Mode	Modulation Mode	N <sub>TX</sub>	Freq. (MHz)	Measured Value(dB)	Duty Factor (dB)	Peak Excursion (dB)	Limit
11a	BPSK	4	5700	7.32	0.00	7.32	13
11a	QPSK	4	5700	7.79	0.00	7.79	13
11a	16QAM	4	5700	8.44	0.00	8.44	13
11a	64QAM	4	5700	9.41	0.18	9.23	13
VHT20	BPSK	4	5580	7.7	0.00	7.70	13
VHT20	QPSK	4	5580	7.83	0.00	7.83	13
VHT20	16QAM	4	5580	8.35	0.10	8.25	13
VHT20	64QAM	4	5580	9.06	0.27	8.79	13
VHT20	256QAM	4	5580	10.07	0.51	9.56	13
VHT40	BPSK	4	5710	7.72	0.00	7.72	13
VHT40	QPSK	4	5710	8.37	0.15	8.22	13
VHT40	16QAM	4	5710	9.12	0.25	8.87	13
VHT40	64QAM	4	5710	11.03	0.56	10.47	13
VHT40	256QAM	4	5710	8.8	0.64	8.16	13
VHT80	BPSK	4	5690	8.26	0.21	8.05	13
VHT80	QPSK	4	5690	7.72	0.37	7.35	13
VHT80	16QAM	4	5690	8.82	0.38	8.44	13
VHT80	64QAM	4	5690	8.6	1.08	7.52	13
VHT80	256QAM	4	5690	8.38	1.66	6.72	13

Note: Measured value = Peak-max-hold spectrum to the maximum of the average spectrum for continuous transmission. Since the duty cycle is < 98 %, duty factor is required to average spectrum  
Peak exclusion = Measured value – duty factor



### Worst Plots

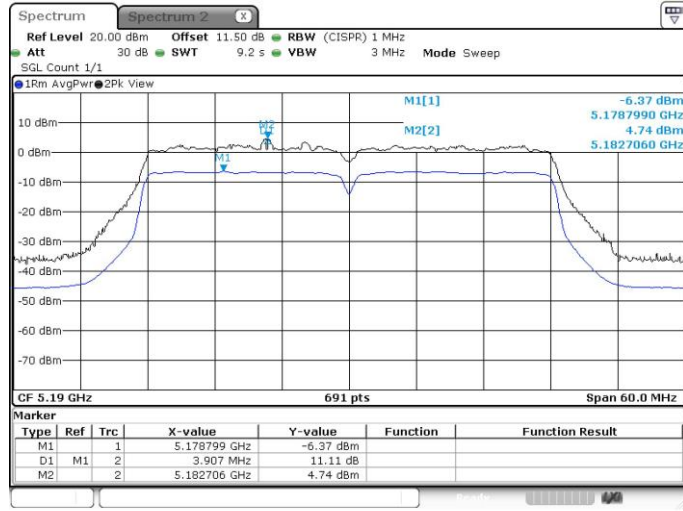

### 3.6 Transmitter Radiated and Band Edge Emissions

#### 3.6.1 Limit of Transmitter Radiated and Band Edge Emissions

Restricted Band Emissions Limit			
Frequency Range (MHz)	Field Strength (uV/m)	Field Strength (dBuV/m)	Measure Distance (m)
0.009~0.490	2400/F(kHz)	48.5 - 13.8	300
0.490~1.705	24000/F(kHz)	33.8 - 23	30
1.705~30.0	30	29	30
30~88	100	40	3
88~216	150	43.5	3
216~960	200	46	3
Above 960	500	54	3

**Note 1:**  
Qusai-Peak value is measured for frequency below 1GHz except for 9–90 kHz, 110–490 kHz frequency band. Peak and average value are measured for frequency above 1GHz. The limit on average radio frequency emission is as above table. The limit on peak radio frequency emissions is 20 dB above the maximum permitted average emission limit

**Note 2:**  
Measurements may be performed at a distance other than what is specified provided. When performing measurements at a distance other than that specified, the results shall be extrapolated to the specified distance using an extrapolation factor as below, Frequency at or above 30 MHz: 20 dB/decade Frequency below 30 MHz: 40 dB/decade.

Un-restricted band emissions above 1GHz Limit	
Operating Band	Limit
5.15 - 5.25 GHz	e.i.r.p. -27 dBm [68.2 dBuV/m@3m]
5.25 - 5.35 GHz	e.i.r.p. -27 dBm [68.2 dBuV/m@3m]
5.47 - 5.725 GHz	e.i.r.p. -27 dBm [68.2 dBuV/m@3m]
5.725 - 5.825 GHz	5.715 5.725 GHz: e.i.r.p. -17 dBm [78.2 dBuV/m@3m] 5.825 5.835 GHz: e.i.r.p. -17 dBm [78.2 dBuV/m@3m] Other un-restricted band: e.i.r.p. -27 dBm [68.2 dBuV/m@3m]

**Note 1:** Measurements may be performed at a distance other than the limit distance provided they are not performed in the near field and the emissions to be measured can be detected by the measurement equipment. When performing measurements at a distance other than that specified, the results shall be extrapolated to the specified distance using an extrapolation factor of 20 dB/decade (inverse of linear distance for field-strength measurements, inverse of linear distance-squared for power-density measurements).

### 3.6.2 Test Procedures

1. Measurement is made at a semi-anechoic chamber that incorporates a turntable allowing a EUT rotation of 360°. A continuously-rotating, remotely-controlled turntable is installed at the test site to support the EUT and facilitate determination of the direction of maximum radiation for each EUT emission frequency. The EUT is placed at a height of 0.8 m test table above the ground plane.
2. Measurement is made with the antenna positioned in both the horizontal and vertical planes of polarization. The measurement antenna is varied in height (1m ~ 4m) above the reference ground plane to obtain the maximum signal strength. Distance between EUT and antenna is 3 m.
3. This investigation is performed with the EUT rotated 360°, the antenna height scanned between 1 m and 4 m, and the antenna rotated to repeat the measurements for both the horizontal and vertical antenna polarizations.

#### Note:

1. 120kHz measurement bandwidth of test receiver and Quasi-peak detector is for radiated emission below 1GHz.
2. RBW=1MHz, VBW=3MHz and Peak detector is for peak measured value of radiated emission above 1GHz.
3. RBW=1MHz, VBW=1/T and Peak detector is for average measured value of radiated emission above 1GHz.

### 3.6.3 Test Setup

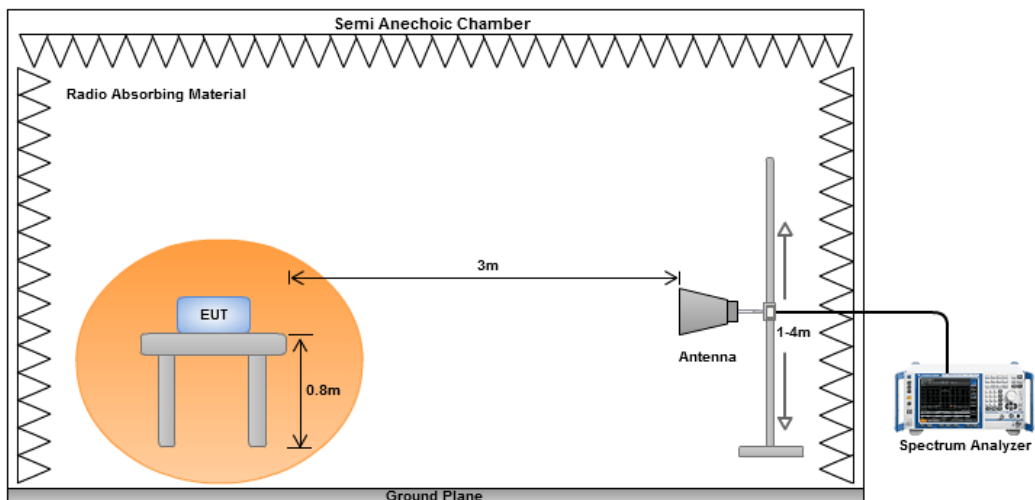

### 3.6.4 Transmitter Radiated Unwanted Emissions (Below 1GHz)

<b>Modulation</b>	VHT40	<b>Test Freq. (MHz)</b>	5510
<b>Polarization</b>	Horizontal		

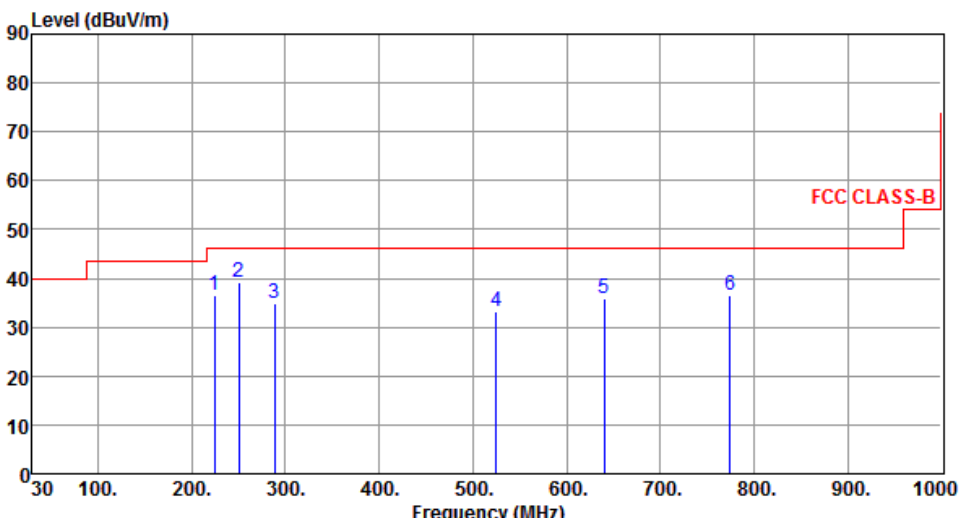

	Freq. MHz	Emission level dBuV/m	Limit dBuV/m	Margin dB	SA reading dBuV	Factor dB	Remark	ANT High cm	Turn Table deg
1	224.75	36.39	46.00	-9.61	55.25	-18.86	Peak	---	---
2	250.42	39.24	46.00	-6.76	57.16	-17.92	Peak	---	---
3	288.53	34.75	46.00	-11.25	51.25	-16.50	Peak	---	---
4	524.64	33.29	46.00	-12.71	44.43	-11.14	Peak	---	---
5	640.27	35.74	46.00	-10.26	44.71	-8.97	Peak	---	---
6	774.58	36.49	46.00	-9.51	43.49	-7.00	Peak	---	---

Note 1: Emission Level (dBuV/m) = SA Reading (dBuV/m) + Factor\* (dB)  
 \*Factor includes antenna factor , cable loss and amplifier gain  
 Note 2: Margin (dB) = Emission level (dBuV/m) – Limit (dBuV/m).  
 Note 3: All spurious emissions below 30MHz are more than 20 dB below the limit.

<b>Modulation</b>	VHT40	<b>Test Freq. (MHz)</b>	5510
<b>Polarization</b>	Vertical		

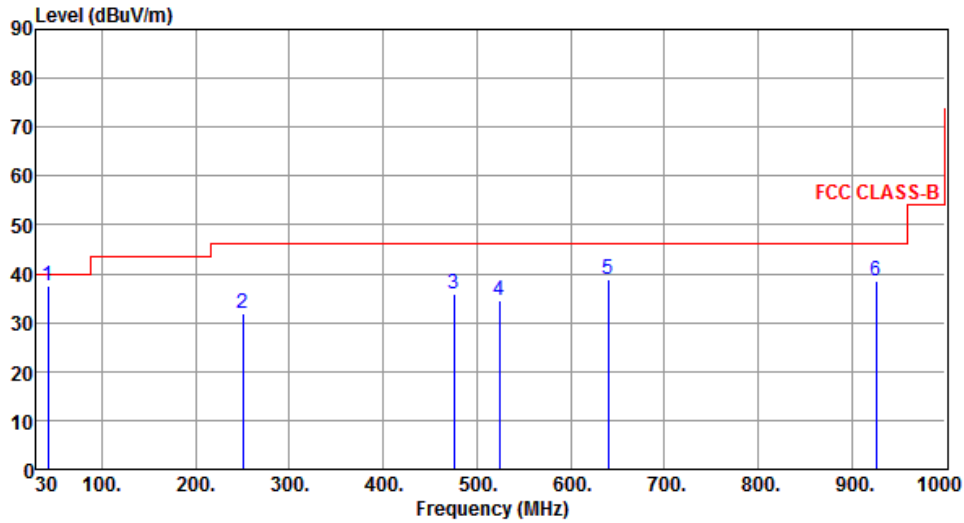

	Freq. MHz	Emission level dBuV/m	Limit dBuV/m	Margin dB	SA reading dBuV	Factor dB	Remark	ANT High cm	Turn Table deg
1	42.28	37.41	40.00	-2.59	54.36	-16.95	QP	---	---
2	250.63	31.87	46.00	-14.13	49.78	-17.91	Peak	---	---
3	475.41	35.94	46.00	-10.06	47.97	-12.03	Peak	---	---
4	524.18	34.54	46.00	-11.46	45.68	-11.14	Peak	---	---
5	640.25	38.99	46.00	-7.01	47.96	-8.97	Peak	---	---
6	925.67	38.41	46.00	-7.59	43.48	-5.07	Peak	---	---

Note 1: Emission Level (dBuV/m) = SA Reading (dBuV/m) + Factor\* (dB)

\*Factor includes antenna factor , cable loss and amplifier gain

Note 2: Margin (dB) = Emission level (dBuV/m) – Limit (dBuV/m).

Note 3: All spurious emissions below 30MHz are more than 20 dB below the limit.

### 3.6.5 Transmitter Radiated Unwanted Emissions (Above 1GHz) for 11a

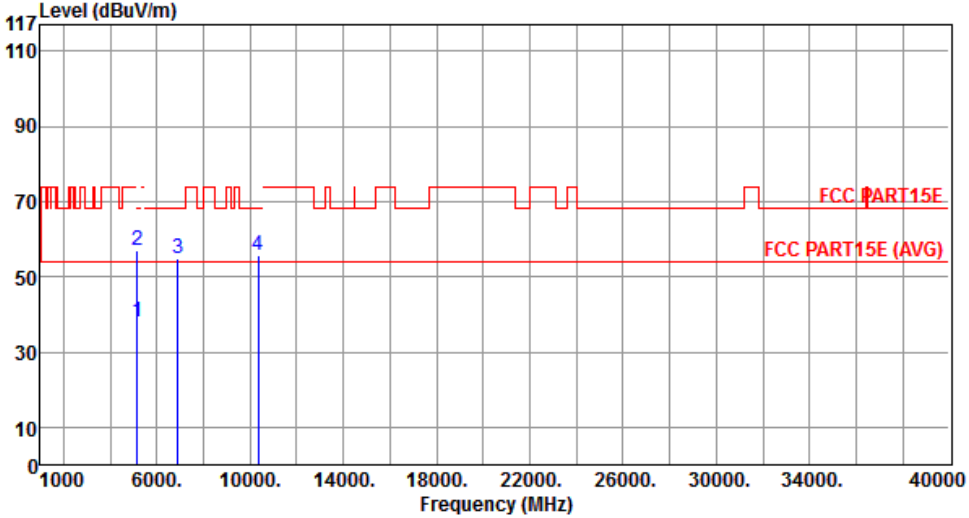
<b>Modulation</b>	11a	<b>Test Freq. (MHz)</b>	5180						
<b>Polarization</b>	Horizontal								
									
	Freq.	Emission level	Limit	Margin	SA reading	Factor	Remark	ANT High	Turn Table
	MHz	dBuV/m	dBuV/m	dB	dBuV	dB		cm	deg
1	5150.00	37.82	54.00	-16.18	32.26	5.56	Average	---	---
2	5150.00	56.91	74.00	-17.09	51.35	5.56	Peak	---	---
3	6906.66	54.95	68.20	-13.25	46.84	8.11	Peak	---	---
4	10360.00	55.53	68.20	-12.67	40.46	15.07	Peak	---	---
<p>Note 1: Emission Level (dBuV/m) = SA Reading (dBuV/m) + Factor* (dB)  *Factor includes antenna factor , cable loss and amplifier gain  Note 2: Margin (dB) = Emission level (dBuV/m) – Limit (dBuV/m).</p>									

<b>Modulation</b>	11a	<b>Test Freq. (MHz)</b>	5180
<b>Polarization</b>	Vertical		

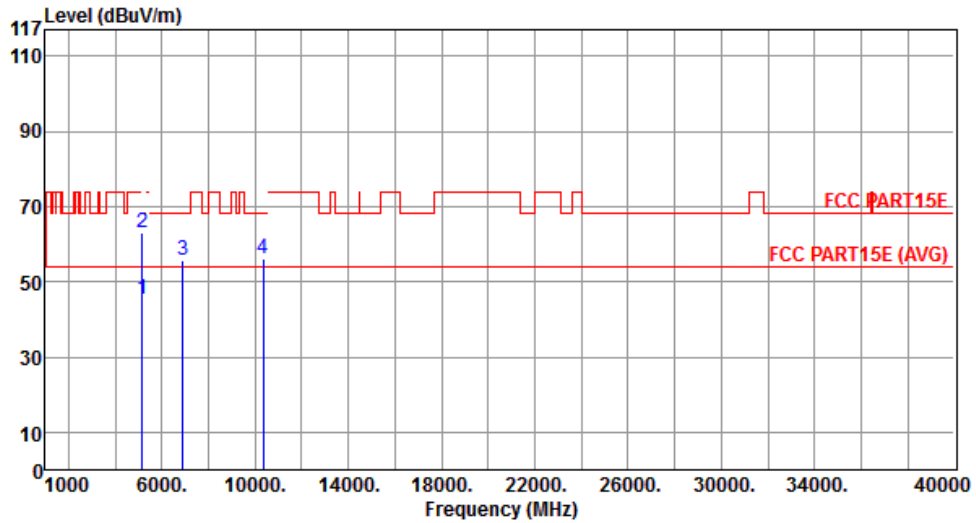

	Freq. MHz	Emission level dBuV/m	Limit dBuV/m	Margin dB	SA reading dBuV	Factor dB	Remark	ANT High cm	Turn Table deg
1	5150.00	45.47	54.00	-8.53	39.91	5.56	Average	---	---
2	5150.00	62.90	74.00	-11.10	57.34	5.56	Peak	---	---
3	6906.66	55.80	68.20	-12.40	47.69	8.11	Peak	---	---
4	10360.00	56.01	68.20	-12.19	40.94	15.07	Peak	---	---

Note 1: Emission Level (dBuV/m) = SA Reading (dBuV/m) + Factor\* (dB)

\*Factor includes antenna factor , cable loss and amplifier gain

Note 2: Margin (dB) = Emission level (dBuV/m) – Limit (dBuV/m).

<b>Modulation</b>	11a	<b>Test Freq. (MHz)</b>	5200
<b>Polarization</b>	Horizontal		

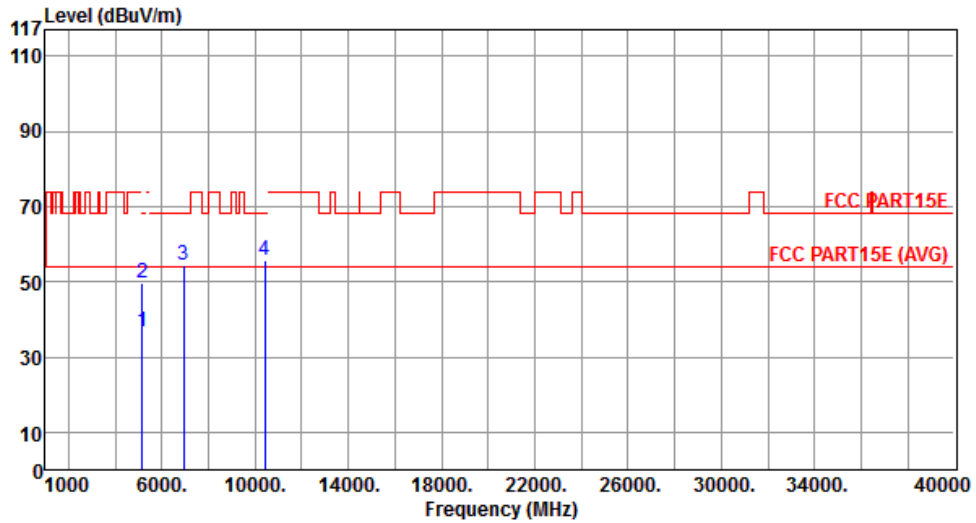

	Freq. MHz	Emission level dBuV/m	Limit dBuV/m	Margin dB	SA reading dBuV	Factor dB	Remark	ANT High cm	Turn Table deg
1	5150.00	36.84	54.00	-17.16	31.28	5.56	Average	---	---
2	5150.00	49.71	74.00	-24.29	44.15	5.56	Peak	---	---
3	6933.33	54.49	68.20	-13.71	46.37	8.12	Peak	---	---
4	10400.00	55.52	68.20	-12.68	40.39	15.13	Peak	---	---

Note 1: Emission Level (dBuV/m) = SA Reading (dBuV/m) + Factor\* (dB)

\*Factor includes antenna factor , cable loss and amplifier gain

Note 2: Margin (dB) = Emission level (dBuV/m) – Limit (dBuV/m).



<b>Modulation</b>	11a	<b>Test Freq. (MHz)</b>	5200
<b>Polarization</b>	Vertical		

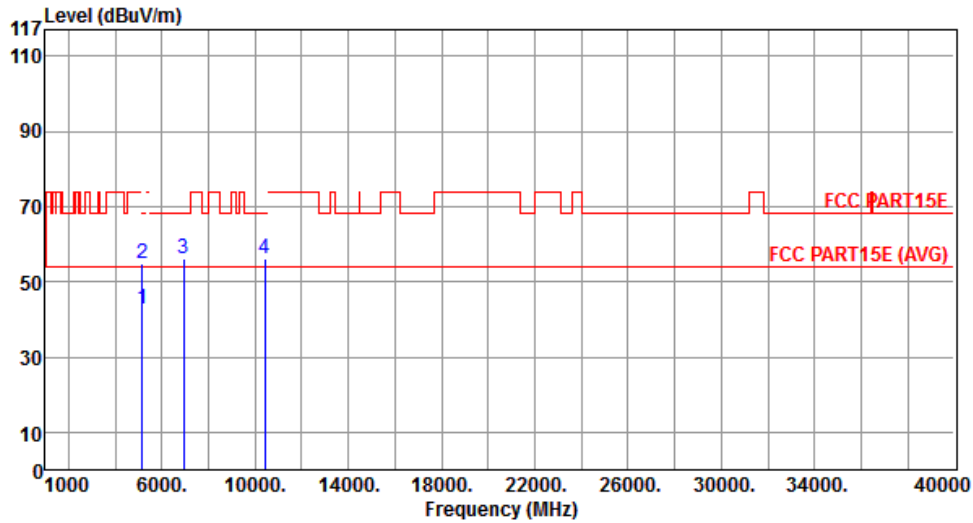

	Freq. MHz	Emission level dBuV/m	Limit dBuV/m	Margin dB	SA reading dBuV	Factor dB	Remark	ANT High cm	Turn Table deg
1	5150.00	42.55	54.00	-11.45	36.99	5.56	Average	---	---
2	5150.00	54.85	74.00	-19.15	49.29	5.56	Peak	---	---
3	6933.33	55.93	68.20	-12.27	47.81	8.12	Peak	---	---
4	10400.00	55.97	68.20	-12.23	40.84	15.13	Peak	---	---

Note 1: Emission Level (dBuV/m) = SA Reading (dBuV/m) + Factor\* (dB)

\*Factor includes antenna factor , cable loss and amplifier gain

Note 2: Margin (dB) = Emission level (dBuV/m) – Limit (dBuV/m).

<b>Modulation</b>	11a	<b>Test Freq. (MHz)</b>	5240
<b>Polarization</b>	Horizontal		

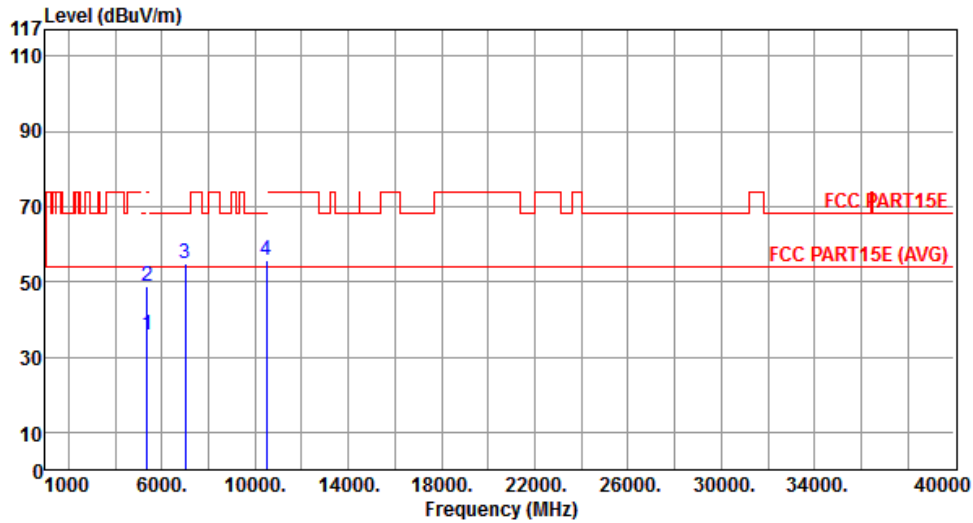

	Freq. MHz	Emission level dBuV/m	Limit dBuV/m	Margin dB	SA reading dBuV	Factor dB	Remark	ANT High cm	Turn Table deg
1	5350.00	35.84	54.00	-18.16	30.13	5.71	Average	---	---
2	5350.00	48.87	74.00	-25.13	43.16	5.71	Peak	---	---
3	6986.66	54.71	68.20	-13.49	46.57	8.14	Peak	---	---
4	10480.00	55.74	68.20	-12.46	40.50	15.24	Peak	---	---

Note 1: Emission Level (dBuV/m) = SA Reading (dBuV/m) + Factor\* (dB)

\*Factor includes antenna factor , cable loss and amplifier gain

Note 2: Margin (dB) = Emission level (dBuV/m) – Limit (dBuV/m).

<b>Modulation</b>	11a	<b>Test Freq. (MHz)</b>	5240
<b>Polarization</b>	Vertical		

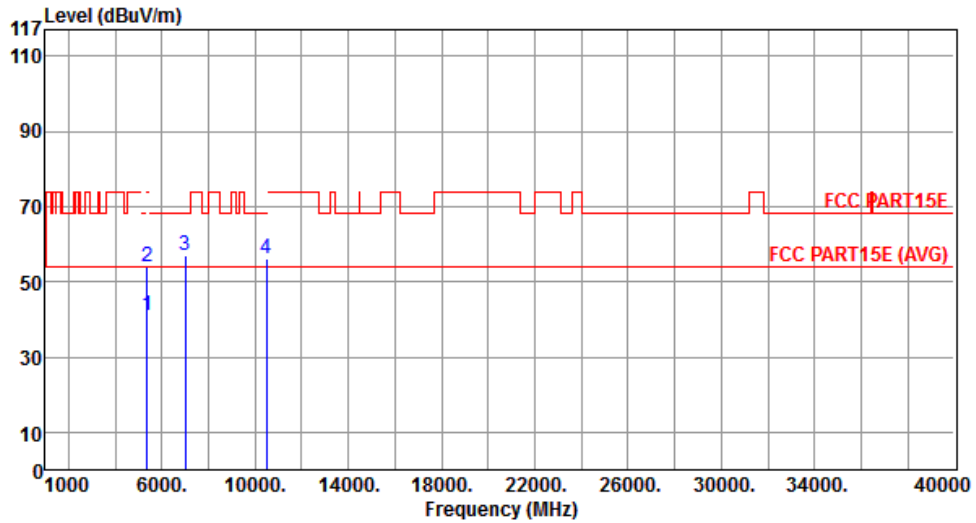

	Freq. MHz	Emission level dBuV/m	Limit dBuV/m	Margin dB	SA reading dBuV	Factor dB	Remark	ANT High cm	Turn Table deg
1	5350.00	40.88	54.00	-13.12	35.17	5.71	Average	---	---
2	5350.00	53.84	74.00	-20.16	48.13	5.71	Peak	---	---
3	6986.66	56.78	68.20	-11.42	48.64	8.14	Peak	---	---
4	10480.00	55.94	68.20	-12.26	40.70	15.24	Peak	---	---

Note 1: Emission Level (dBuV/m) = SA Reading (dBuV/m) + Factor\* (dB)

\*Factor includes antenna factor , cable loss and amplifier gain

Note 2: Margin (dB) = Emission level (dBuV/m) – Limit (dBuV/m).

<b>Modulation</b>	11a	<b>Test Freq. (MHz)</b>	5260
<b>Polarization</b>	Horizontal		

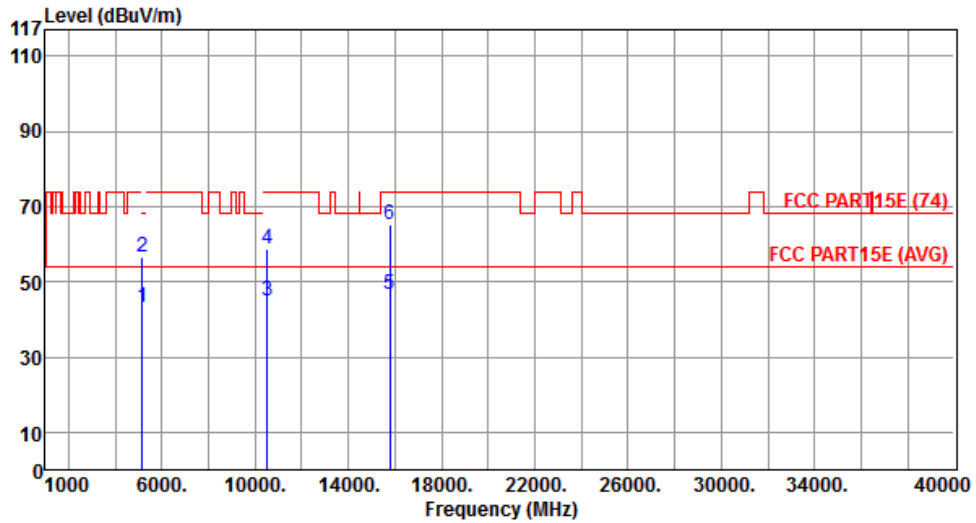

	Freq. MHz	Emission level dBuV/m	Limit dBuV/m	Margin dB	SA reading dBuV	Factor dB	Remark	ANT High cm	Turn Table deg
1	5150.00	43.21	54.00	-10.79	37.65	5.56	Average	---	---
2	5150.00	56.76	74.00	-17.24	51.20	5.56	Peak	---	---
3	10520.00	44.75	54.00	-9.25	29.48	15.27	Average	---	---
4	10520.00	58.83	74.00	-15.17	43.56	15.27	Peak	---	---
5	15780.00	46.84	54.00	-7.16	32.66	14.18	Average	---	---
6	15780.00	65.09	74.00	-8.91	50.91	14.18	Peak	---	---

Note 1: Emission Level (dBuV/m) = SA Reading (dBuV/m) + Factor\* (dB)

\*Factor includes antenna factor , cable loss and amplifier gain

Note 2: Margin (dB) = Emission level (dBuV/m) – Limit (dBuV/m).

<b>Modulation</b>	11a	<b>Test Freq. (MHz)</b>	5260
<b>Polarization</b>	Vertical		

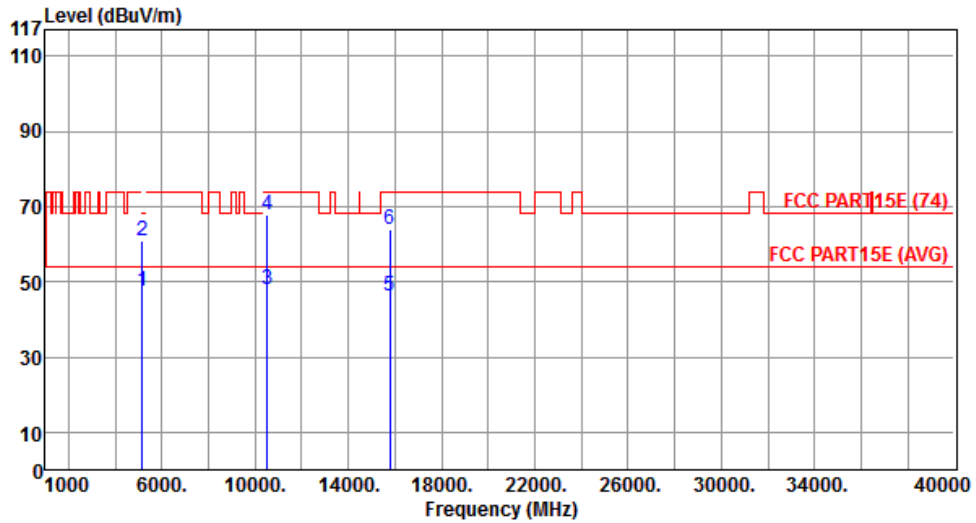

	Freq. MHz	Emission level dBuV/m	Limit dBuV/m	Margin dB	SA reading dBuV	Factor dB	Remark	ANT High cm	Turn Table deg
1	5150.00	47.52	54.00	-6.48	41.96	5.56	Average	---	---
2	5150.00	60.98	74.00	-13.02	55.42	5.56	Peak	---	---
3	10520.00	47.73	54.00	-6.27	32.46	15.27	Average	---	---
4	10520.00	67.64	74.00	-6.36	52.37	15.27	Peak	---	---
5	15780.00	46.32	54.00	-7.68	32.14	14.18	Average	---	---
6	15780.00	63.77	74.00	-10.23	49.59	14.18	Peak	---	---

Note 1: Emission Level (dBuV/m) = SA Reading (dBuV/m) + Factor\* (dB)

\*Factor includes antenna factor , cable loss and amplifier gain

Note 2: Margin (dB) = Emission level (dBuV/m) – Limit (dBuV/m).

<b>Modulation</b>	11a	<b>Test Freq. (MHz)</b>	5300
<b>Polarization</b>	Horizontal		

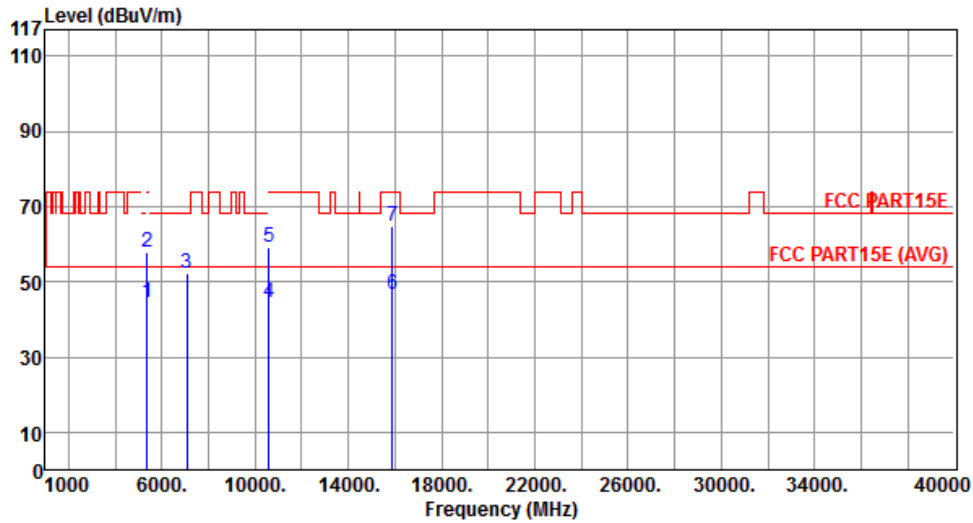

	Freq. MHz	Emission level dBuV/m	Limit dBuV/m	Margin dB	SA reading dBuV	Factor dB	Remark	ANT High cm	Turn Table deg
1	5350.00	44.25	54.00	-9.75	38.54	5.71	Average	---	---
2	5350.00	57.79	74.00	-16.21	52.08	5.71	Peak	---	---
3	7066.66	52.33	68.20	-15.87	43.82	8.51	Peak	---	---
4	10600.00	44.65	54.00	-9.35	29.35	15.30	Average	---	---
5	10600.00	59.17	74.00	-14.83	43.87	15.30	Peak	---	---
6	15900.00	46.51	54.00	-7.49	32.51	14.00	Average	---	---
7	15900.00	64.74	74.00	-9.26	50.74	14.00	Peak	---	---

Note 1: Emission Level (dBuV/m) = SA Reading (dBuV/m) + Factor\* (dB)

\*Factor includes antenna factor, cable loss and amplifier gain

Note 2: Margin (dB) = Emission level (dBuV/m) – Limit (dBuV/m).

<b>Modulation</b>	11a	<b>Test Freq. (MHz)</b>	5300
<b>Polarization</b>	Vertical		

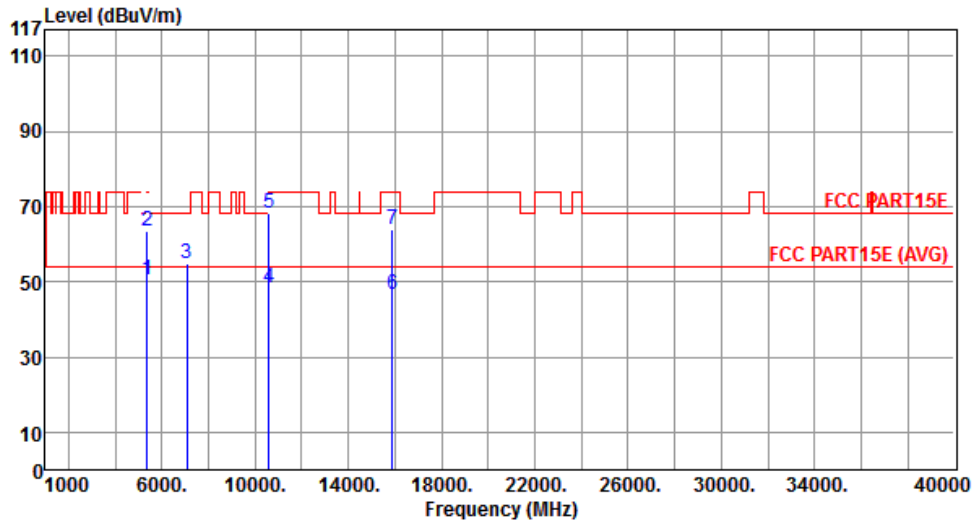

	Freq. MHz	Emission level dBuV/m	Limit dBuV/m	Margin dB	SA reading dBuV	Factor dB	Remark	ANT High cm	Turn Table deg
1	5350.00	50.64	54.00	-3.36	44.93	5.71	Average	---	---
2	5350.00	63.41	74.00	-10.59	57.70	5.71	Peak	---	---
3	7066.66	54.76	68.20	-13.44	46.25	8.51	Peak	---	---
4	10600.00	48.36	54.00	-5.64	33.06	15.30	Average	---	---
5	10600.00	68.14	74.00	-5.86	52.84	15.30	Peak	---	---
6	15900.00	46.48	54.00	-7.52	32.48	14.00	Average	---	---
7	15900.00	63.72	74.00	-10.28	49.72	14.00	Peak	---	---

Note 1: Emission Level (dBuV/m) = SA Reading (dBuV/m) + Factor\* (dB)

\*Factor includes antenna factor , cable loss and amplifier gain

Note 2: Margin (dB) = Emission level (dBuV/m) – Limit (dBuV/m).

<b>Modulation</b>	11a	<b>Test Freq. (MHz)</b>	5320
<b>Polarization</b>	Horizontal		

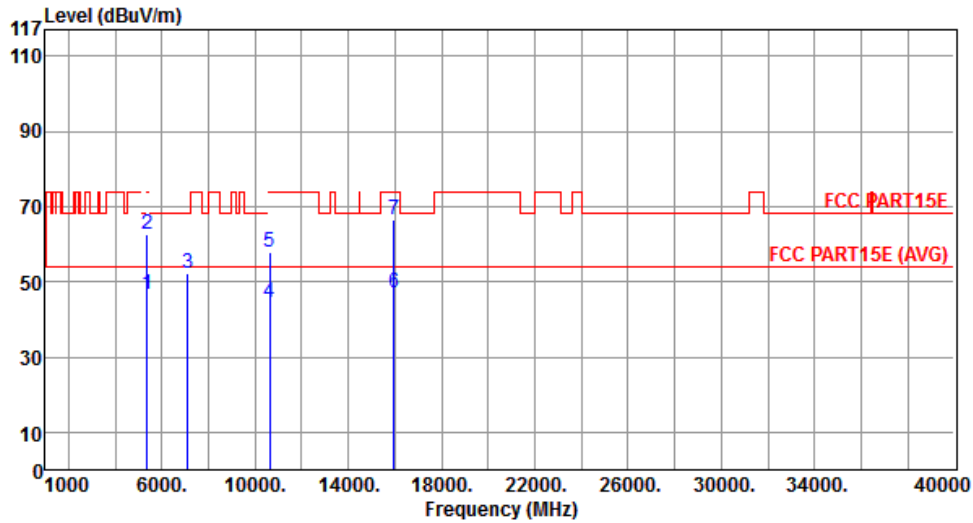

	Freq. MHz	Emission level dBuV/m	Limit dBuV/m	Margin dB	SA reading dBuV	Factor dB	Remark	ANT High cm	Turn Table deg
1	5350.00	46.45	54.00	-7.55	40.74	5.71	Average	---	---
2	5350.00	62.69	74.00	-11.31	56.98	5.71	Peak	---	---
3	7120.00	52.40	68.20	-15.80	43.59	8.81	Peak	---	---
4	10640.00	44.53	54.00	-9.47	29.21	15.32	Average	---	---
5	10640.00	57.95	74.00	-16.05	42.63	15.32	Peak	---	---
6	15960.00	47.07	54.00	-6.93	33.16	13.91	Average	---	---
7	15960.00	66.67	74.00	-7.33	52.76	13.91	Peak	---	---

Note 1: Emission Level (dBuV/m) = SA Reading (dBuV/m) + Factor\* (dB)

\*Factor includes antenna factor , cable loss and amplifier gain

Note 2: Margin (dB) = Emission level (dBuV/m) – Limit (dBuV/m).



<b>Modulation</b>	11a	<b>Test Freq. (MHz)</b>	5320
<b>Polarization</b>	Vertical		

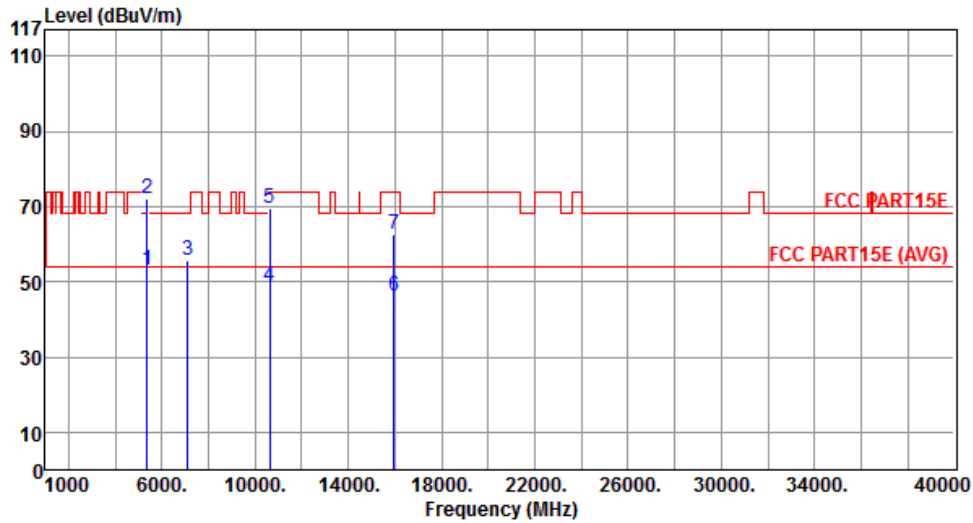

	Freq. MHz	Emission level dBuV/m	Limit dBuV/m	Margin dB	SA reading dBuV	Factor dB	Remark	ANT High cm	Turn Table deg
1	5350.00	52.95	54.00	-1.05	47.24	5.71	Average	---	---
2	5350.00	72.05	74.00	-1.95	66.34	5.71	Peak	---	---
3	7120.00	55.80	68.20	-12.40	46.99	8.81	Peak	---	---
4	10640.00	48.88	54.00	-5.12	33.56	15.32	Average	---	---
5	10640.00	69.63	74.00	-4.37	54.31	15.32	Peak	---	---
6	15960.00	46.27	54.00	-7.73	32.36	13.91	Average	---	---
7	15960.00	62.48	74.00	-11.52	48.57	13.91	Peak	---	---

Note 1: Emission Level (dBuV/m) = SA Reading (dBuV/m) + Factor\* (dB)

\*Factor includes antenna factor , cable loss and amplifier gain

Note 2: Margin (dB) = Emission level (dBuV/m) – Limit (dBuV/m).

<b>Modulation</b>	11a	<b>Test Freq. (MHz)</b>	5500
<b>Polarization</b>	Horizontal		

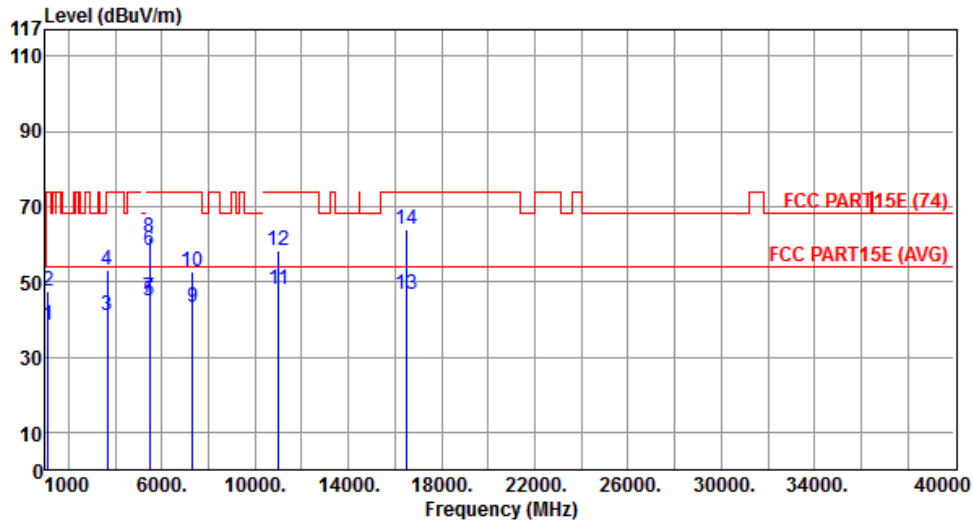

	Freq. MHz	Emission level dBuV/m	Limit dBuV/m	Margin dB	SA reading dBuV	Factor dB	Remark	ANT High cm	Turn Table deg
1	1125.00	38.25	54.00	-15.75	47.76	-9.51	Average	---	---
2	1125.00	47.44	74.00	-26.56	56.95	-9.51	Peak	---	---
3	3666.66	41.15	54.00	-12.85	40.83	0.32	Average	---	---
4	3666.66	53.13	74.00	-20.87	52.81	0.32	Peak	---	---
5	5460.00	45.02	54.00	-8.98	39.34	5.68	Average	---	---
6	5460.00	58.18	74.00	-15.82	52.50	5.68	Peak	---	---
7	5470.00	45.86	54.00	-8.14	40.20	5.66	Average	---	---
8	5470.00	61.82	74.00	-12.18	56.16	5.66	Peak	---	---
9	7333.33	43.03	54.00	-10.97	33.67	9.36	Average	---	---
10	7333.33	52.65	74.00	-21.35	43.29	9.36	Peak	---	---
11	11000.00	47.86	54.00	-6.14	32.41	15.45	Average	---	---
12	11000.00	58.39	74.00	-15.61	42.94	15.45	Peak	---	---
13	16500.00	46.68	54.00	-7.32	30.62	16.06	Average	---	---
14	16500.00	63.76	74.00	-10.24	47.70	16.06	Peak	---	---

Note 1: Emission Level (dBuV/m) = SA Reading (dBuV/m) + Factor\* (dB)

\*Factor includes antenna factor , cable loss and amplifier gain

Note 2: Margin (dB) = Emission level (dBuV/m) – Limit (dBuV/m).

<b>Modulation</b>	11a	<b>Test Freq. (MHz)</b>	5500
<b>Polarization</b>	Vertical		

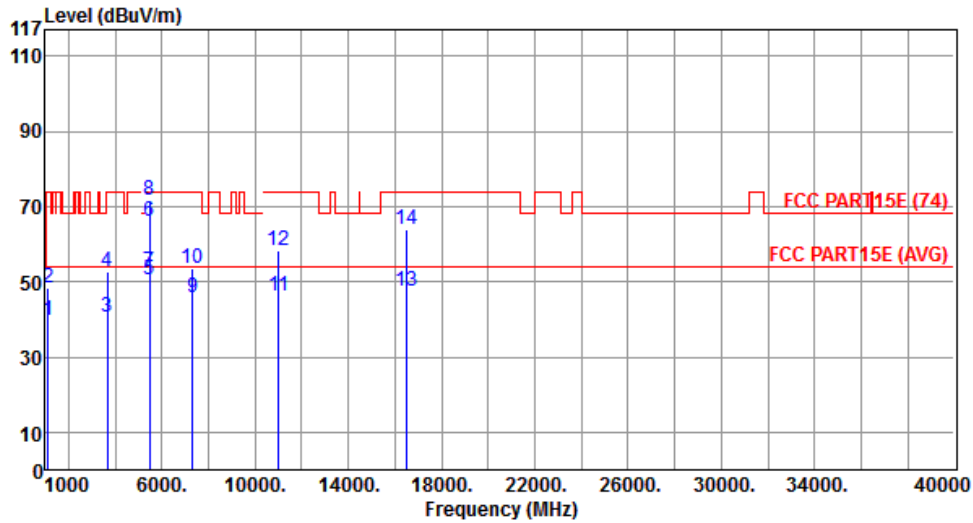

	Freq. MHz	Emission level dBuV/m	Limit dBuV/m	Margin dB	SA reading dBuV	Factor dB	Remark	ANT High cm	Turn Table deg
1	1125.00	39.77	54.00	-14.23	49.28	-9.51	Average	---	---
2	1125.00	48.36	74.00	-25.64	57.87	-9.51	Peak	---	---
3	3666.66	40.75	54.00	-13.25	40.43	0.32	Average	---	---
4	3666.66	52.72	74.00	-21.28	52.40	0.32	Peak	---	---
5	5460.00	50.44	54.00	-3.56	44.76	5.68	Average	---	---
6	5460.00	65.92	74.00	-8.08	60.24	5.68	Peak	---	---
7	5470.00	52.69	54.00	-1.31	47.03	5.66	Average	---	---
8	5470.00	71.61	74.00	-2.39	65.95	5.66	Peak	---	---
9	7333.33	45.93	54.00	-8.07	36.57	9.36	Average	---	---
10	7333.33	53.73	74.00	-20.27	44.37	9.36	Peak	---	---
11	11000.00	46.03	54.00	-7.97	30.58	15.45	Average	---	---
12	11000.00	58.39	74.00	-15.61	42.94	15.45	Peak	---	---
13	16500.00	47.35	54.00	-6.65	31.29	16.06	Average	---	---
14	16500.00	63.99	74.00	-10.01	47.93	16.06	Peak	---	---

Note 1: Emission Level (dBuV/m) = SA Reading (dBuV/m) + Factor\* (dB)

\*Factor includes antenna factor , cable loss and amplifier gain

Note 2: Margin (dB) = Emission level (dBuV/m) – Limit (dBuV/m).

<b>Modulation</b>	11a	<b>Test Freq. (MHz)</b>	5580
<b>Polarization</b>	Horizontal		

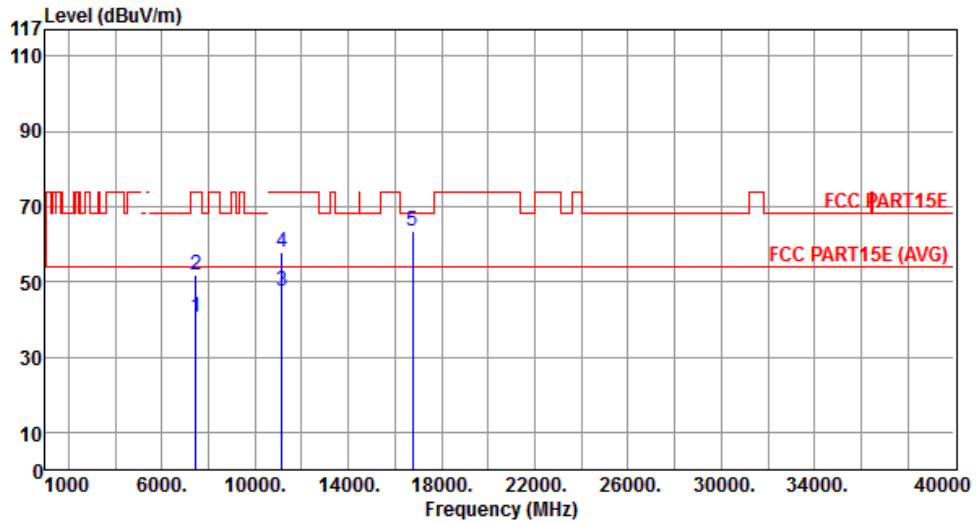

	Freq. MHz	Emission level dBuV/m	Limit dBuV/m	Margin dB	SA reading dBuV	Factor dB	Remark	ANT High cm	Turn Table deg
1	7440.00	40.59	54.00	-13.41	31.00	9.59	Average	---	---
2	7440.00	52.00	74.00	-22.00	42.41	9.59	Peak	---	---
3	11160.00	47.37	54.00	-6.63	32.20	15.17	Average	---	---
4	11160.00	57.74	74.00	-16.26	42.57	15.17	Peak	---	---
5	16740.00	63.59	68.20	-4.61	46.95	16.64	Peak	---	---

Note 1: Emission Level (dBuV/m) = SA Reading (dBuV/m) + Factor\* (dB)

\*Factor includes antenna factor, cable loss and amplifier gain

Note 2: Margin (dB) = Emission level (dBuV/m) – Limit (dBuV/m).

<b>Modulation</b>	11a	<b>Test Freq. (MHz)</b>	5580
<b>Polarization</b>	Vertical		

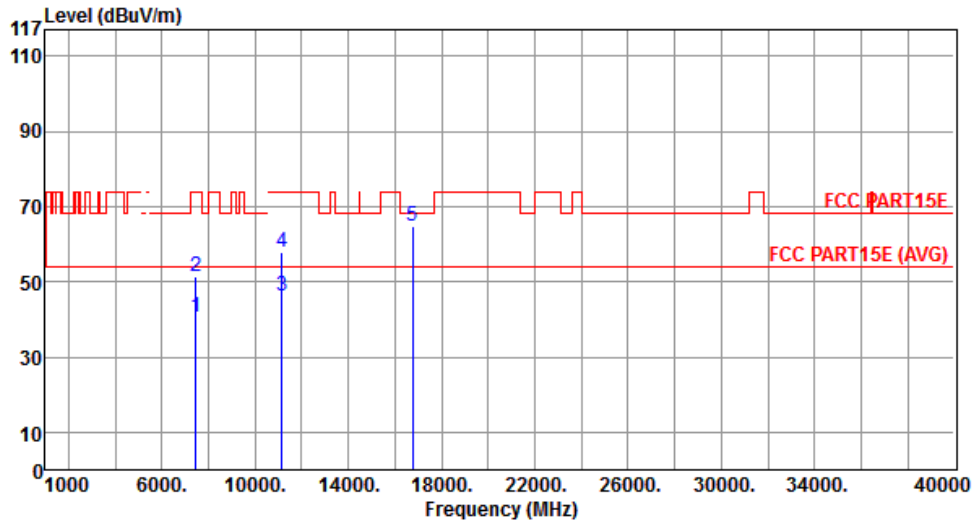

	Freq. MHz	Emission level dBuV/m	Limit dBuV/m	Margin dB	SA reading dBuV	Factor dB	Remark	ANT High cm	Turn Table deg
1	7440.00	40.60	54.00	-13.40	31.01	9.59	Average	---	---
2	7440.00	51.32	74.00	-22.68	41.73	9.59	Peak	---	---
3	11160.00	46.19	54.00	-7.81	31.02	15.17	Average	---	---
4	11160.00	58.05	74.00	-15.95	42.88	15.17	Peak	---	---
5	16740.00	64.83	68.20	-3.37	48.19	16.64	Peak	---	---

Note 1: Emission Level (dBuV/m) = SA Reading (dBuV/m) + Factor\* (dB)

\*Factor includes antenna factor , cable loss and amplifier gain

Note 2: Margin (dB) = Emission level (dBuV/m) – Limit (dBuV/m).

<b>Modulation</b>	11a	<b>Test Freq. (MHz)</b>	5700
<b>Polarization</b>	Horizontal		

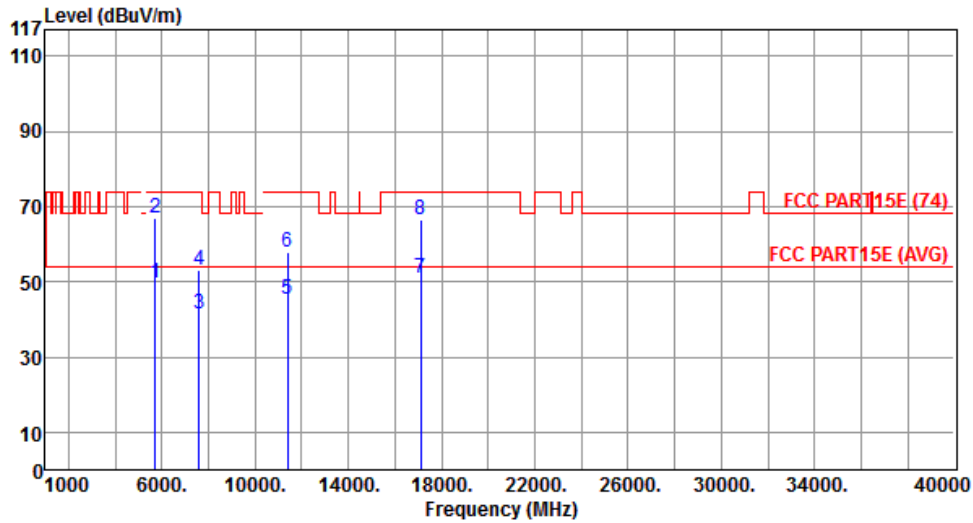

	Freq. MHz	Emission level dBuV/m	Limit dBuV/m	Margin dB	SA reading dBuV	Factor dB	Remark	ANT High cm	Turn Table deg
1	5725.00	49.46	54.00	-4.54	43.88	5.58	Average	---	---
2	5725.00	66.75	74.00	-7.25	61.17	5.58	Peak	---	---
3	7600.00	41.55	54.00	-12.45	31.24	10.31	Average	---	---
4	7600.00	52.89	74.00	-21.11	42.58	10.31	Peak	---	---
5	11400.00	45.48	54.00	-8.52	30.74	14.74	Average	---	---
6	11400.00	57.78	74.00	-16.22	43.04	14.74	Peak	---	---
7	17100.00	51.16	54.00	-2.84	33.46	17.70	Average	---	---
8	17100.00	66.70	74.00	-7.30	49.00	17.70	Peak	---	---

Note 1: Emission Level (dBuV/m) = SA Reading (dBuV/m) + Factor\* (dB)

\*Factor includes antenna factor , cable loss and amplifier gain

Note 2: Margin (dB) = Emission level (dBuV/m) – Limit (dBuV/m).

<b>Modulation</b>	11a	<b>Test Freq. (MHz)</b>	5700
<b>Polarization</b>	Vertical		

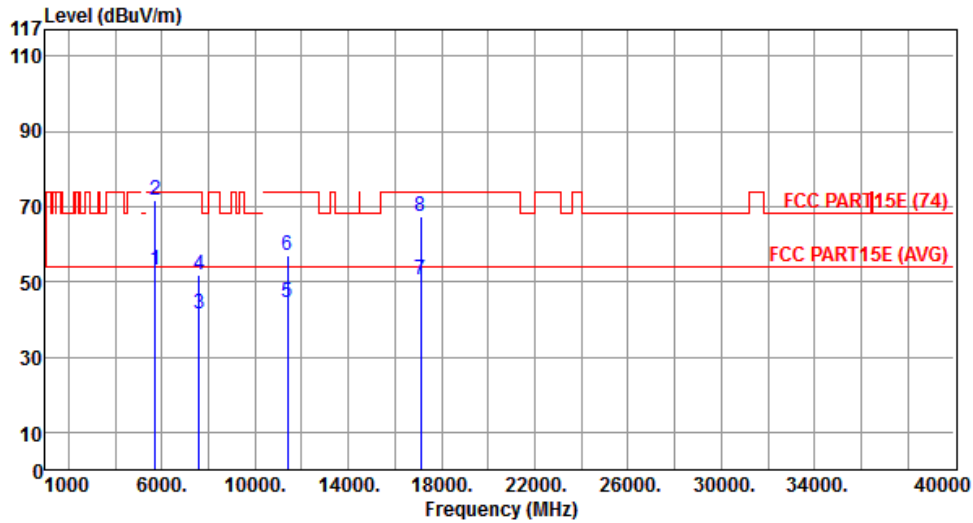

	Freq. MHz	Emission level dBuV/m	Limit dBuV/m	Margin dB	SA reading dBuV	Factor dB	Remark	ANT High cm	Turn Table deg
1	5725.00	53.00	54.00	-1.00	47.42	5.58	Average	---	---
2	5725.00	71.70	74.00	-2.30	66.12	5.58	Peak	---	---
3	7600.00	41.49	54.00	-12.51	31.18	10.31	Average	---	---
4	7600.00	51.95	74.00	-22.05	41.64	10.31	Peak	---	---
5	11400.00	44.68	54.00	-9.32	29.94	14.74	Average	---	---
6	11400.00	57.10	74.00	-16.90	42.36	14.74	Peak	---	---
7	17100.00	50.69	54.00	-3.31	32.99	17.70	Average	---	---
8	17100.00	67.21	74.00	-6.79	49.51	17.70	Peak	---	---

Note 1: Emission Level (dBuV/m) = SA Reading (dBuV/m) + Factor\* (dB)

\*Factor includes antenna factor , cable loss and amplifier gain

Note 2: Margin (dB) = Emission level (dBuV/m) – Limit (dBuV/m).

<b>Modulation</b>	11a	<b>Test Freq. (MHz)</b>	5720
<b>Polarization</b>	Horizontal		

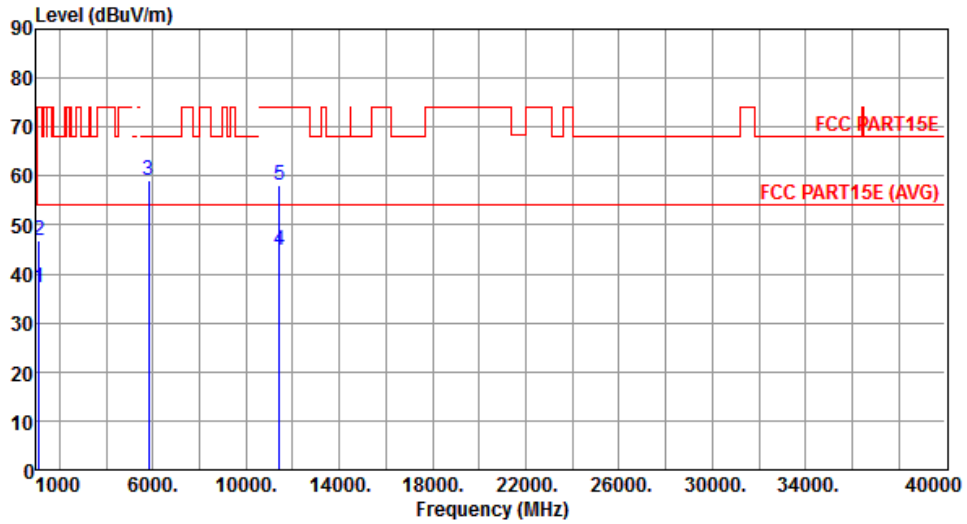

	Freq. MHz	Emission level dBuV/m	Limit dBuV/m	Margin dB	SA reading dBuV	Factor dB	Remark	ANT High cm	Turn Table deg
1	1125.00	37.33	54.00	-16.67	46.84	-9.51	Average	---	---
2	1125.00	46.87	74.00	-27.13	56.38	-9.51	Peak	---	---
3	5825.00	59.20	68.20	-9.00	53.58	5.62	Peak	---	---
4	11440.00	44.76	54.00	-9.24	30.10	14.66	Average	---	---
5	11440.00	58.17	74.00	-15.83	43.51	14.66	Peak	---	---

Note 1: Emission Level (dBuV/m) = SA Reading (dBuV/m) + Factor\* (dB)

\*Factor includes antenna factor , cable loss and amplifier gain

Note 2: Margin (dB) = Emission level (dBuV/m) – Limit (dBuV/m).



<b>Modulation</b>	11a	<b>Test Freq. (MHz)</b>	5720
<b>Polarization</b>	Vertical		

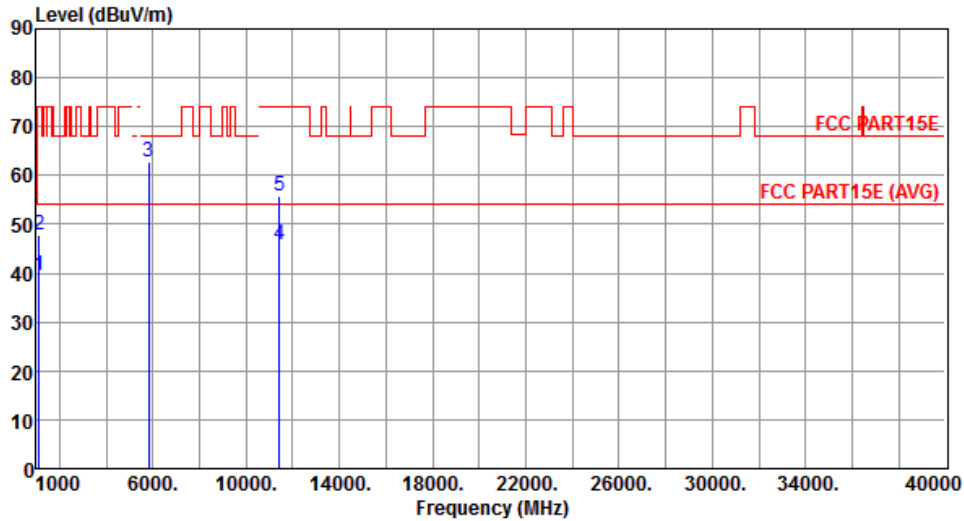

	Freq. MHz	Emission level dBuV/m	Limit dBuV/m	Margin dB	SA reading dBuV	Factor dB	Remark	ANT High cm	Turn Table deg
1	1125.00	39.46	54.00	-14.54	48.97	-9.51	Average	---	---
2	1125.00	47.88	74.00	-26.12	57.39	-9.51	Peak	---	---
3	5825.00	62.71	68.20	-5.49	57.09	5.62	Peak	---	---
4	11440.00	45.71	54.00	-8.29	31.05	14.66	Average	---	---
5	11440.00	55.95	74.00	-18.05	41.29	14.66	Peak	---	---

Note 1: Emission Level (dBuV/m) = SA Reading (dBuV/m) + Factor\* (dB)

\*Factor includes antenna factor , cable loss and amplifier gain

Note 2: Margin (dB) = Emission level (dBuV/m) – Limit (dBuV/m).

### 3.6.6 Transmitter Radiated Unwanted Emissions (Above 1GHz) for VHT20

<b>Modulation</b>	VHT20	<b>Test Freq. (MHz)</b>	5180
<b>Polarization</b>	Horizontal		

  

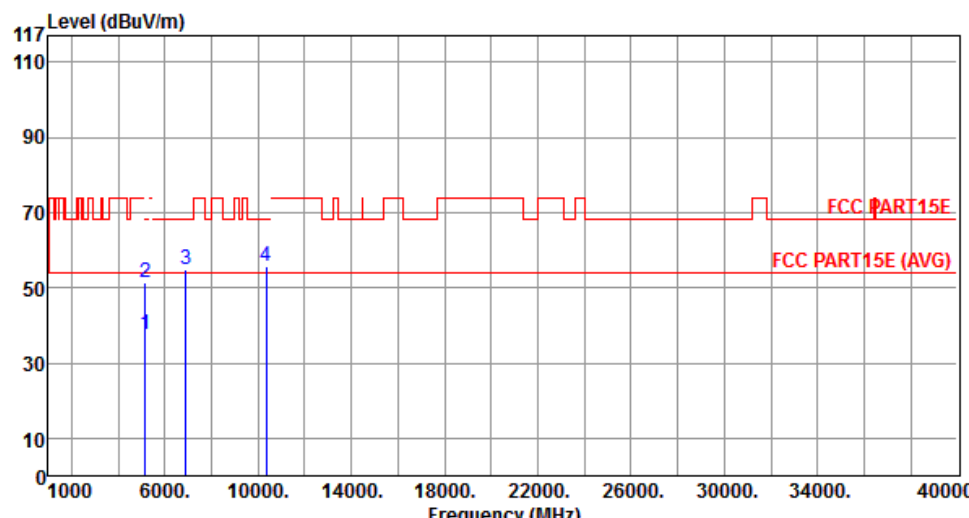

	Freq. MHz	Emission level dBuV/m	Limit dBuV/m	Margin dB	SA reading dBuV	Factor dB	Remark	ANT High cm	Turn Table deg
1	5150.00	37.65	54.00	-16.35	32.09	5.56	Average	---	---
2	5150.00	51.24	74.00	-22.76	45.68	5.56	Peak	---	---
3	6906.66	54.70	68.20	-13.50	46.59	8.11	Peak	---	---
4	10360.00	55.59	68.20	-12.61	40.52	15.07	Peak	---	---

Note 1: Emission Level (dBuV/m) = SA Reading (dBuV/m) + Factor\* (dB)  
\*Factor includes antenna factor , cable loss and amplifier gain  
Note 2: Margin (dB) = Emission level (dBuV/m) – Limit (dBuV/m).

<b>Modulation</b>	VHT20	<b>Test Freq. (MHz)</b>	5180
<b>Polarization</b>	Vertical		

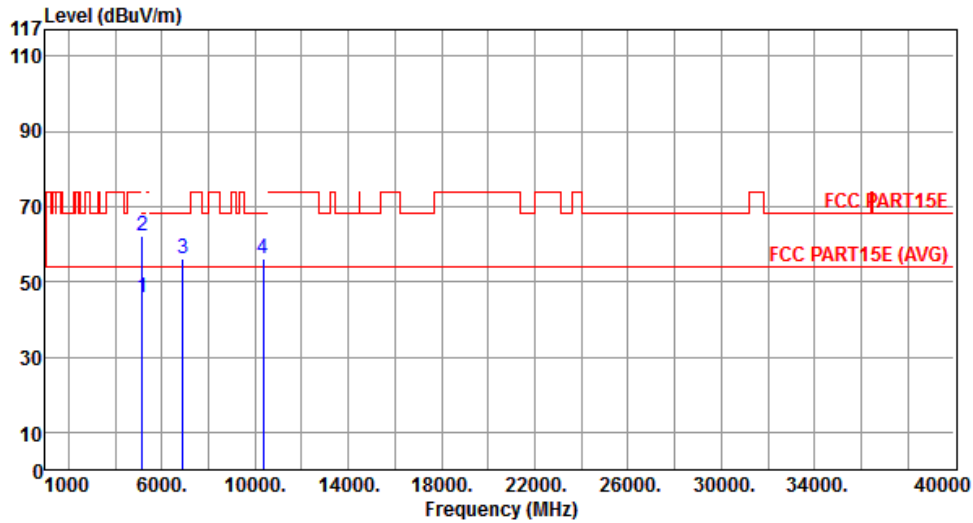

	Freq. MHz	Emission level dBuV/m	Limit dBuV/m	Margin dB	SA reading dBuV	Factor dB	Remark	ANT High cm	Turn Table deg
1	5150.00	45.65	54.00	-8.35	40.09	5.56	Average	---	---
2	5150.00	62.34	74.00	-11.66	56.78	5.56	Peak	---	---
3	6906.66	56.18	68.20	-12.02	48.07	8.11	Peak	---	---
4	10360.00	55.94	68.20	-12.26	40.87	15.07	Peak	---	---

Note 1: Emission Level (dBuV/m) = SA Reading (dBuV/m) + Factor\* (dB)

\*Factor includes antenna factor , cable loss and amplifier gain

Note 2: Margin (dB) = Emission level (dBuV/m) – Limit (dBuV/m).

<b>Modulation</b>	VHT20	<b>Test Freq. (MHz)</b>	5200
<b>Polarization</b>	Horizontal		

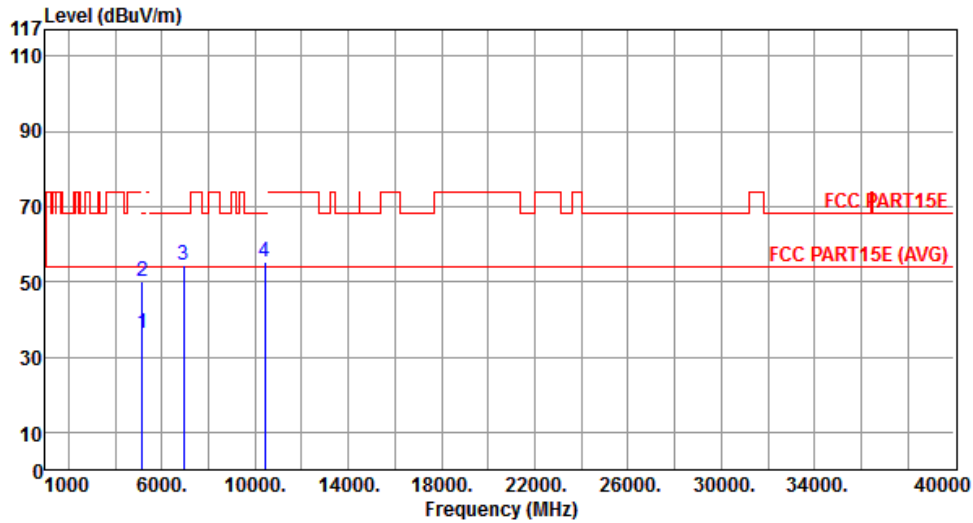

	Freq. MHz	Emission level dBuV/m	Limit dBuV/m	Margin dB	SA reading dBuV	Factor dB	Remark	ANT High cm	Turn Table deg
1	5150.00	36.21	54.00	-17.79	30.65	5.56	Average	---	---
2	5150.00	50.10	74.00	-23.90	44.54	5.56	Peak	---	---
3	6933.33	54.30	68.20	-13.90	46.18	8.12	Peak	---	---
4	10400.00	55.38	68.20	-12.82	40.25	15.13	Peak	---	---

Note 1: Emission Level (dBuV/m) = SA Reading (dBuV/m) + Factor\* (dB)

\*Factor includes antenna factor , cable loss and amplifier gain

Note 2: Margin (dB) = Emission level (dBuV/m) – Limit (dBuV/m).

<b>Modulation</b>	VHT20	<b>Test Freq. (MHz)</b>	5200
<b>Polarization</b>	Vertical		

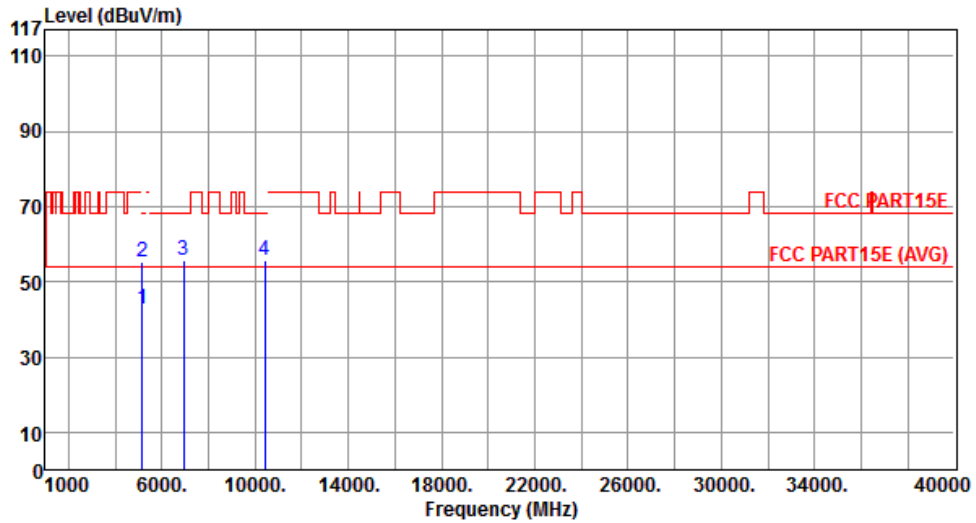

	Freq. MHz	Emission level dBuV/m	Limit dBuV/m	Margin dB	SA reading dBuV	Factor dB	Remark	ANT High cm	Turn Table deg
1	5150.00	42.84	54.00	-11.16	37.28	5.56	Average	---	---
2	5150.00	55.12	74.00	-18.88	49.56	5.56	Peak	---	---
3	6933.33	55.70	68.20	-12.50	47.58	8.12	Peak	---	---
4	10400.00	55.77	68.20	-12.43	40.64	15.13	Peak	---	---

Note 1: Emission Level (dBuV/m) = SA Reading (dBuV/m) + Factor\* (dB)

\*Factor includes antenna factor , cable loss and amplifier gain

Note 2: Margin (dB) = Emission level (dBuV/m) – Limit (dBuV/m).

<b>Modulation</b>	VHT20	<b>Test Freq. (MHz)</b>	5240
<b>Polarization</b>	Horizontal		

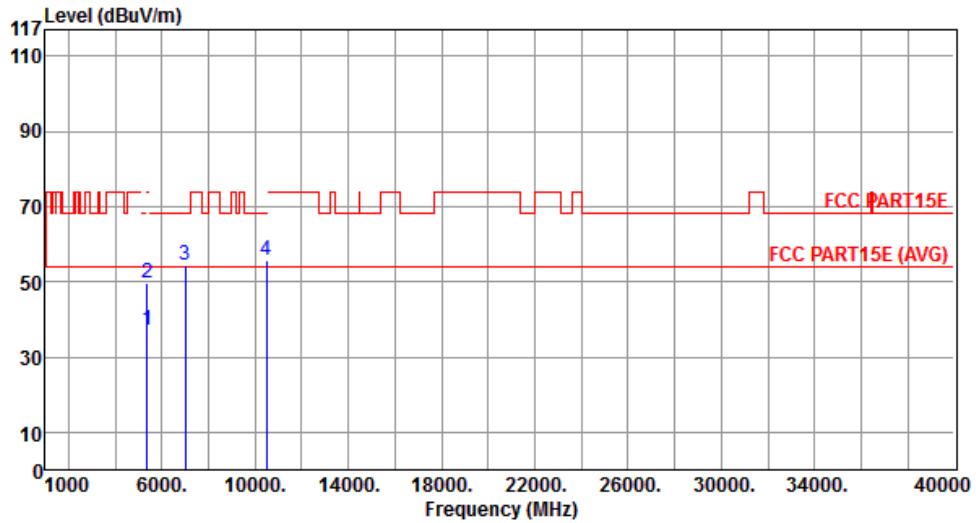

	Freq. MHz	Emission level dBuV/m	Limit dBuV/m	Margin dB	SA reading dBuV	Factor dB	Remark	ANT High cm	Turn Table deg
1	5350.00	36.94	54.00	-17.06	31.23	5.71	Average	---	---
2	5350.00	49.64	74.00	-24.36	43.93	5.71	Peak	---	---
3	6986.66	54.38	68.20	-13.82	46.24	8.14	Peak	---	---
4	10480.00	55.60	68.20	-12.60	40.36	15.24	Peak	---	---

Note 1: Emission Level (dBuV/m) = SA Reading (dBuV/m) + Factor\* (dB)

\*Factor includes antenna factor , cable loss and amplifier gain

Note 2: Margin (dB) = Emission level (dBuV/m) – Limit (dBuV/m).

<b>Modulation</b>	VHT20	<b>Test Freq. (MHz)</b>	5240
<b>Polarization</b>	Vertical		

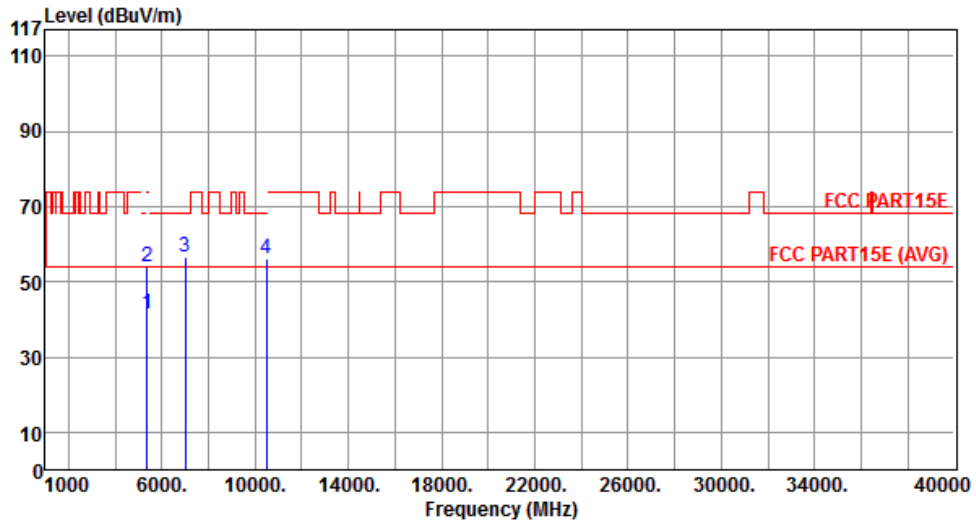

	Freq. MHz	Emission level dBuV/m	Limit dBuV/m	Margin dB	SA reading dBuV	Factor dB	Remark	ANT High cm	Turn Table deg
1	5350.00	41.40	54.00	-12.60	35.69	5.71	Average	---	---
2	5350.00	53.84	74.00	-20.16	48.13	5.71	Peak	---	---
3	6986.66	56.37	68.20	-11.83	48.23	8.14	Peak	---	---
4	10480.00	56.14	68.20	-12.06	40.90	15.24	Peak	---	---

Note 1: Emission Level (dBuV/m) = SA Reading (dBuV/m) + Factor\* (dB)

\*Factor includes antenna factor , cable loss and amplifier gain

Note 2: Margin (dB) = Emission level (dBuV/m) – Limit (dBuV/m).

<b>Modulation</b>	VHT20	<b>Test Freq. (MHz)</b>	5260
<b>Polarization</b>	Horizontal		

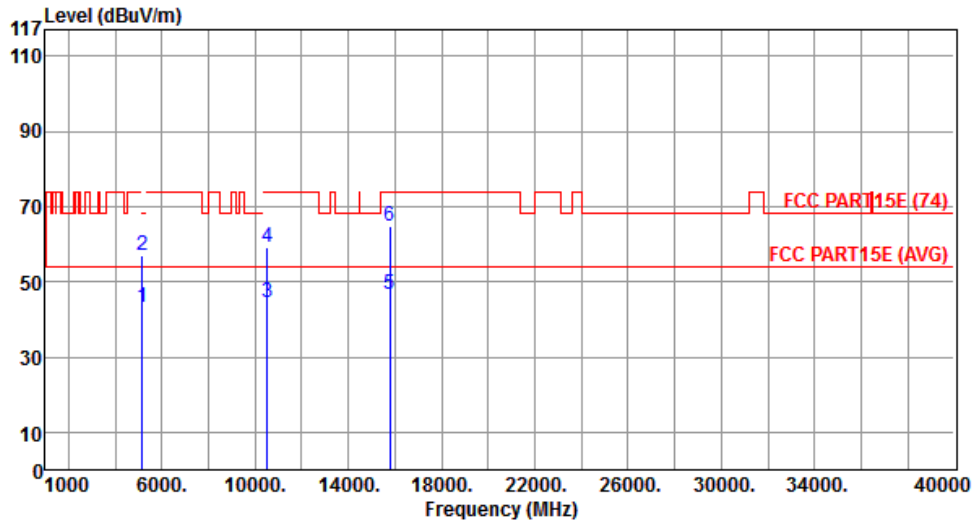

	Freq. MHz	Emission level dBuV/m	Limit dBuV/m	Margin dB	SA reading dBuV	Factor dB	Remark	ANT High cm	Turn Table deg
1	5150.00	43.28	54.00	-10.72	37.72	5.56	Average	---	---
2	5150.00	57.16	74.00	-16.84	51.60	5.56	Peak	---	---
3	10520.00	44.58	54.00	-9.42	29.31	15.27	Average	---	---
4	10520.00	59.01	74.00	-14.99	43.74	15.27	Peak	---	---
5	15780.00	46.63	54.00	-7.37	32.45	14.18	Average	---	---
6	15780.00	64.86	74.00	-9.14	50.68	14.18	Peak	---	---

Note 1: Emission Level (dBuV/m) = SA Reading (dBuV/m) + Factor\* (dB)

\*Factor includes antenna factor , cable loss and amplifier gain

Note 2: Margin (dB) = Emission level (dBuV/m) – Limit (dBuV/m).



<b>Modulation</b>	VHT20	<b>Test Freq. (MHz)</b>	5260
<b>Polarization</b>	Vertical		

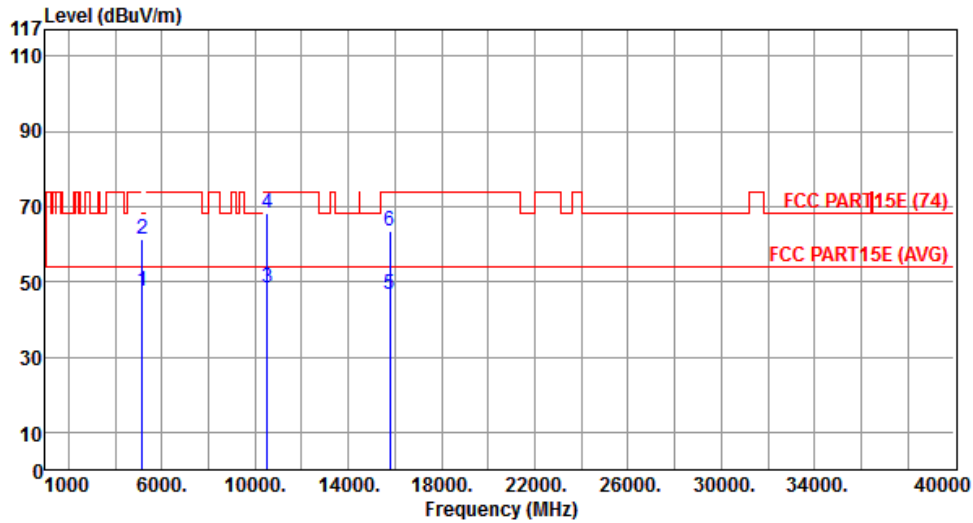

	Freq. MHz	Emission level dBuV/m	Limit dBuV/m	Margin dB	SA reading dBuV	Factor dB	Remark	ANT High cm	Turn Table deg
1	5150.00	47.45	54.00	-6.55	41.89	5.56	Average	---	---
2	5150.00	61.48	74.00	-12.52	55.92	5.56	Peak	---	---
3	10520.00	48.21	54.00	-5.79	32.94	15.27	Average	---	---
4	10520.00	68.08	74.00	-5.92	52.81	15.27	Peak	---	---
5	15780.00	46.63	54.00	-7.37	32.45	14.18	Average	---	---
6	15780.00	63.46	74.00	-10.54	49.28	14.18	Peak	---	---

Note 1: Emission Level (dBuV/m) = SA Reading (dBuV/m) + Factor\* (dB)

\*Factor includes antenna factor , cable loss and amplifier gain

Note 2: Margin (dB) = Emission level (dBuV/m) – Limit (dBuV/m).

<b>Modulation</b>	VHT20	<b>Test Freq. (MHz)</b>	5300
<b>Polarization</b>	Horizontal		

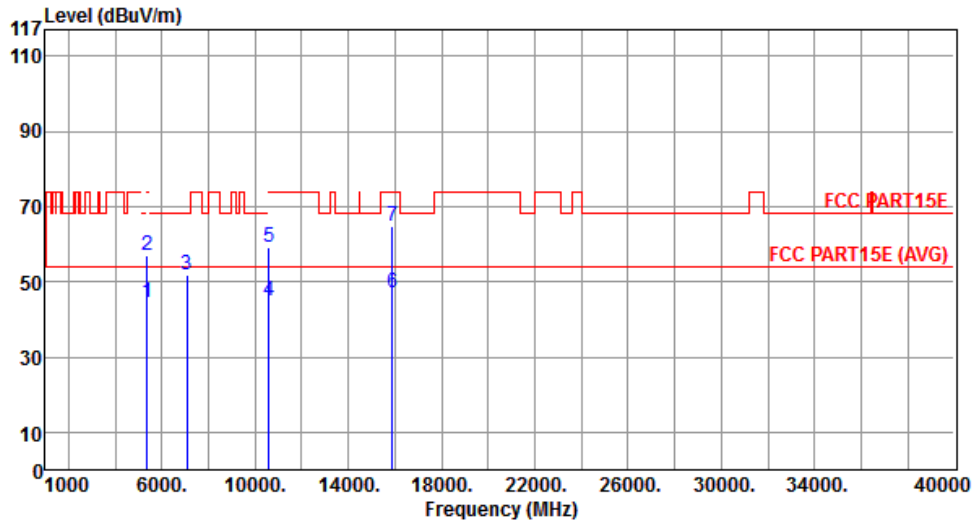

	Freq. MHz	Emission level dBuV/m	Limit dBuV/m	Margin dB	SA reading dBuV	Factor dB	Remark	ANT High cm	Turn Table deg
1	5350.00	44.47	54.00	-9.53	38.76	5.71	Average	---	---
2	5350.00	57.16	74.00	-16.84	51.45	5.71	Peak	---	---
3	7066.66	52.00	68.20	-16.20	43.49	8.51	Peak	---	---
4	10600.00	44.77	54.00	-9.23	29.47	15.30	Average	---	---
5	10600.00	59.20	74.00	-14.80	43.90	15.30	Peak	---	---
6	15900.00	46.90	54.00	-7.10	32.90	14.00	Average	---	---
7	15900.00	64.92	74.00	-9.08	50.92	14.00	Peak	---	---

Note 1: Emission Level (dBuV/m) = SA Reading (dBuV/m) + Factor\* (dB)

\*Factor includes antenna factor , cable loss and amplifier gain

Note 2: Margin (dB) = Emission level (dBuV/m) – Limit (dBuV/m).

<b>Modulation</b>	VHT20	<b>Test Freq. (MHz)</b>	5300
<b>Polarization</b>	Vertical		

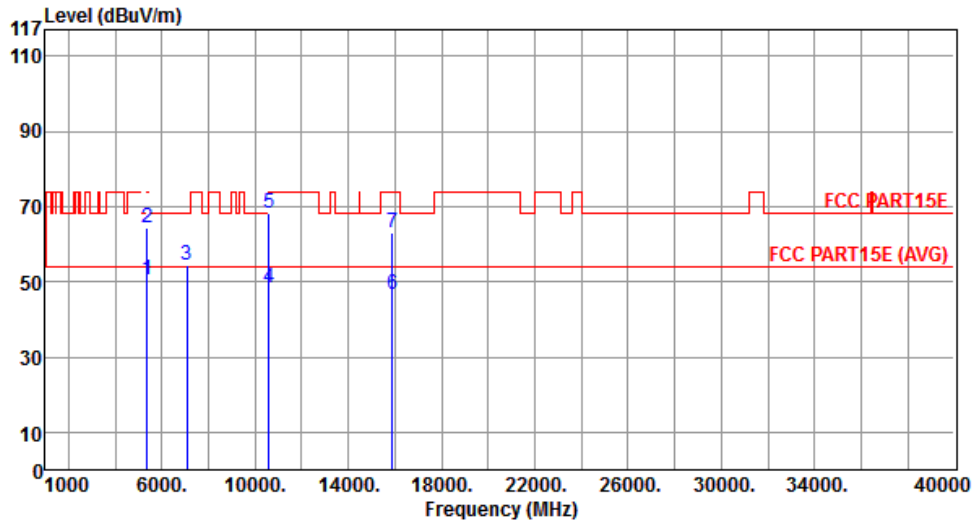

	Freq. MHz	Emission level dBuV/m	Limit dBuV/m	Margin dB	SA reading dBuV	Factor dB	Remark	ANT High cm	Turn Table deg
1	5350.00	50.72	54.00	-3.28	45.01	5.71	Average	---	---
2	5350.00	64.23	74.00	-9.77	58.52	5.71	Peak	---	---
3	7066.66	54.53	68.20	-13.67	46.02	8.51	Peak	---	---
4	10600.00	48.42	54.00	-5.58	33.12	15.30	Average	---	---
5	10600.00	68.27	74.00	-5.73	52.97	15.30	Peak	---	---
6	15900.00	46.61	54.00	-7.39	32.61	14.00	Average	---	---
7	15900.00	63.06	74.00	-10.94	49.06	14.00	Peak	---	---

Note 1: Emission Level (dBuV/m) = SA Reading (dBuV/m) + Factor\* (dB)

\*Factor includes antenna factor , cable loss and amplifier gain

Note 2: Margin (dB) = Emission level (dBuV/m) – Limit (dBuV/m).

<b>Modulation</b>	VHT20	<b>Test Freq. (MHz)</b>	5320
<b>Polarization</b>	Horizontal		

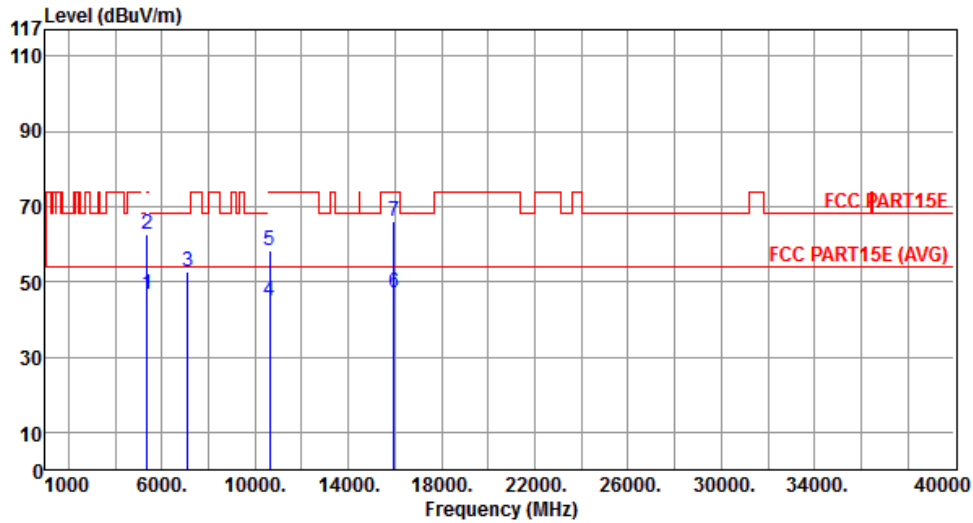

	Freq. MHz	Emission level dBuV/m	Limit dBuV/m	Margin dB	SA reading dBuV	Factor dB	Remark	ANT High cm	Turn Table deg
1	5350.00	46.63	54.00	-7.37	40.92	5.71	Average	---	---
2	5350.00	62.39	74.00	-11.61	56.68	5.71	Peak	---	---
3	7120.00	52.62	68.20	-15.58	43.81	8.81	Peak	---	---
4	10640.00	44.69	54.00	-9.31	29.37	15.32	Average	---	---
5	10640.00	58.30	74.00	-15.70	42.98	15.32	Peak	---	---
6	15960.00	46.99	54.00	-7.01	33.08	13.91	Average	---	---
7	15960.00	66.22	74.00	-7.78	52.31	13.91	Peak	---	---

Note 1: Emission Level (dBuV/m) = SA Reading (dBuV/m) + Factor\* (dB)

\*Factor includes antenna factor , cable loss and amplifier gain

Note 2: Margin (dB) = Emission level (dBuV/m) – Limit (dBuV/m).

<b>Modulation</b>	VHT20	<b>Test Freq. (MHz)</b>	5320
<b>Polarization</b>	Vertical		

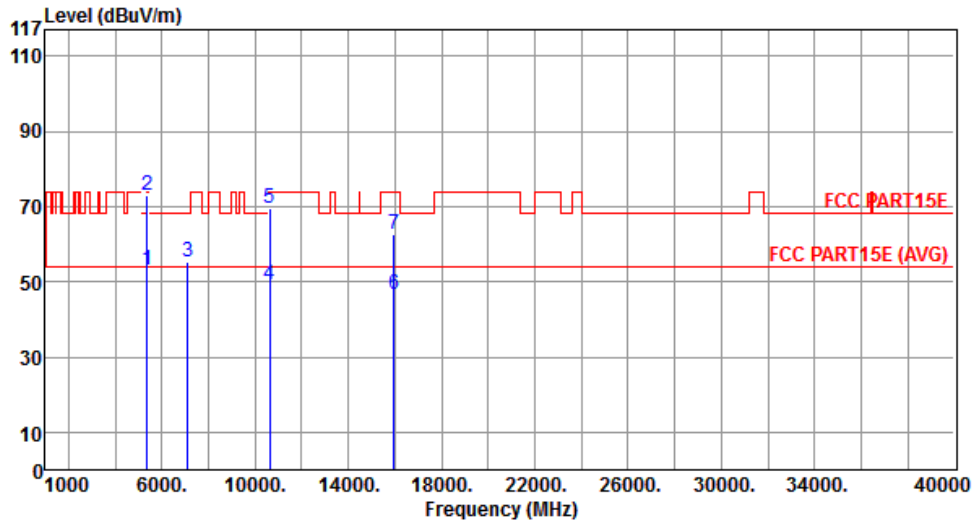

	Freq. MHz	Emission level dBuV/m	Limit dBuV/m	Margin dB	SA reading dBuV	Factor dB	Remark	ANT High cm	Turn Table deg
1	5350.00	53.00	54.00	-1.00	47.29	5.71	Average	---	---
2	5350.00	72.79	74.00	-1.21	67.08	5.71	Peak	---	---
3	7120.00	55.45	68.20	-12.75	46.64	8.81	Peak	---	---
4	10640.00	49.29	54.00	-4.71	33.97	15.32	Average	---	---
5	10640.00	69.38	74.00	-4.62	54.06	15.32	Peak	---	---
6	15960.00	46.55	54.00	-7.45	32.64	13.91	Average	---	---
7	15960.00	62.72	74.00	-11.28	48.81	13.91	Peak	---	---

Note 1: Emission Level (dBuV/m) = SA Reading (dBuV/m) + Factor\* (dB)

\*Factor includes antenna factor , cable loss and amplifier gain

Note 2: Margin (dB) = Emission level (dBuV/m) – Limit (dBuV/m).

<b>Modulation</b>	VHT20	<b>Test Freq. (MHz)</b>	5500
<b>Polarization</b>	Horizontal		

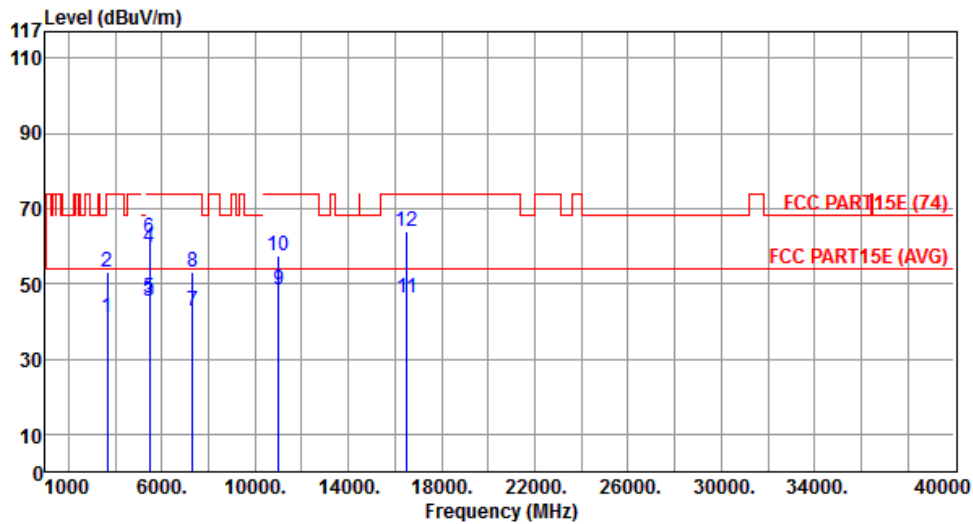

	Freq. MHz	Emission level dBuV/m	Limit dBuV/m	Margin dB	SA reading dBuV	Factor dB	Remark	ANT High cm	Turn Table deg
1	3666.66	40.90	54.00	-13.10	40.58	0.32	Average	---	---
2	3666.66	53.07	74.00	-20.93	52.75	0.32	Peak	---	---
3	5460.00	45.23	54.00	-8.77	39.55	5.68	Average	---	---
4	5460.00	59.55	74.00	-14.45	53.87	5.68	Peak	---	---
5	5470.00	45.99	54.00	-8.01	40.33	5.66	Average	---	---
6	5470.00	62.01	74.00	-11.99	56.35	5.66	Peak	---	---
7	7333.33	42.80	54.00	-11.20	33.44	9.36	Average	---	---
8	7333.33	53.03	74.00	-20.97	43.67	9.36	Peak	---	---
9	11000.00	48.39	54.00	-5.61	32.94	15.45	Average	---	---
10	11000.00	57.63	74.00	-16.37	42.18	15.45	Peak	---	---
11	16500.00	46.30	54.00	-7.70	30.24	16.06	Average	---	---
12	16500.00	63.99	74.00	-10.01	47.93	16.06	Peak	---	---

Note 1: Emission Level (dBuV/m) = SA Reading (dBuV/m) + Factor\* (dB)

\*Factor includes antenna factor , cable loss and amplifier gain

Note 2: Margin (dB) = Emission level (dBuV/m) – Limit (dBuV/m).

<b>Modulation</b>	VHT20	<b>Test Freq. (MHz)</b>	5500
<b>Polarization</b>	Vertical		

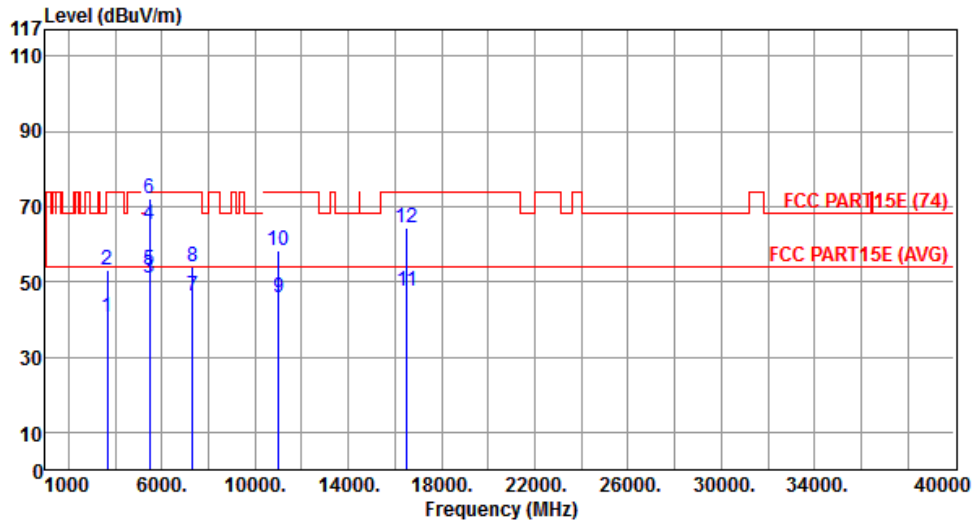

	Freq. MHz	Emission level dBuV/m	Limit dBuV/m	Margin dB	SA reading dBuV	Factor dB	Remark	ANT High cm	Turn Table deg
1	3666.66	40.74	54.00	-13.26	40.42	0.32	Average	---	---
2	3666.66	53.21	74.00	-20.79	52.89	0.32	Peak	---	---
3	5460.00	50.78	54.00	-3.22	45.10	5.68	Average	---	---
4	5460.00	65.19	74.00	-8.81	59.51	5.68	Peak	---	---
5	5470.00	52.99	54.00	-1.01	47.33	5.66	Average	---	---
6	5470.00	71.93	74.00	-2.07	66.27	5.66	Peak	---	---
7	7333.33	46.30	54.00	-7.70	36.94	9.36	Average	---	---
8	7333.33	53.77	74.00	-20.23	44.41	9.36	Peak	---	---
9	11000.00	45.86	54.00	-8.14	30.41	15.45	Average	---	---
10	11000.00	58.21	74.00	-15.79	42.76	15.45	Peak	---	---
11	16500.00	47.51	54.00	-6.49	31.45	16.06	Average	---	---
12	16500.00	64.20	74.00	-9.80	48.14	16.06	Peak	---	---

Note 1: Emission Level (dBuV/m) = SA Reading (dBuV/m) + Factor\* (dB)  
 \*Factor includes antenna factor , cable loss and amplifier gain  
 Note 2: Margin (dB) = Emission level (dBuV/m) – Limit (dBuV/m).

<b>Modulation</b>	VHT20	<b>Test Freq. (MHz)</b>	5580
<b>Polarization</b>	Horizontal		

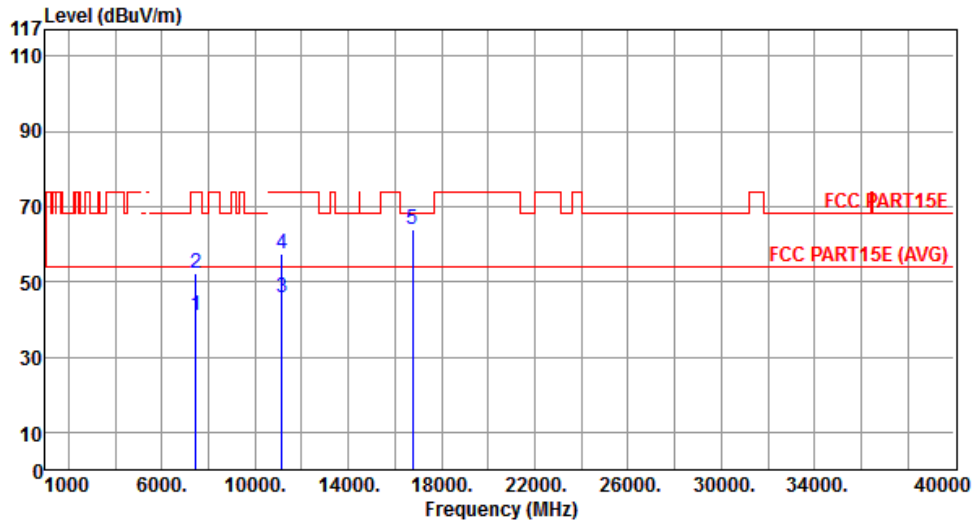

	Freq. MHz	Emission level dBuV/m	Limit dBuV/m	Margin dB	SA reading dBuV	Factor dB	Remark	ANT High cm	Turn Table deg
1	7440.00	40.85	54.00	-13.15	31.26	9.59	Average	---	---
2	7440.00	52.26	74.00	-21.74	42.67	9.59	Peak	---	---
3	11160.00	45.88	54.00	-8.12	30.71	15.17	Average	---	---
4	11160.00	57.61	74.00	-16.39	42.44	15.17	Peak	---	---
5	16740.00	63.94	68.20	-4.26	47.30	16.64	Peak	---	---

Note 1: Emission Level (dBuV/m) = SA Reading (dBuV/m) + Factor\* (dB)

\*Factor includes antenna factor , cable loss and amplifier gain

Note 2: Margin (dB) = Emission level (dBuV/m) – Limit (dBuV/m).



<b>Modulation</b>	VHT20	<b>Test Freq. (MHz)</b>	5580
<b>Polarization</b>	Vertical		

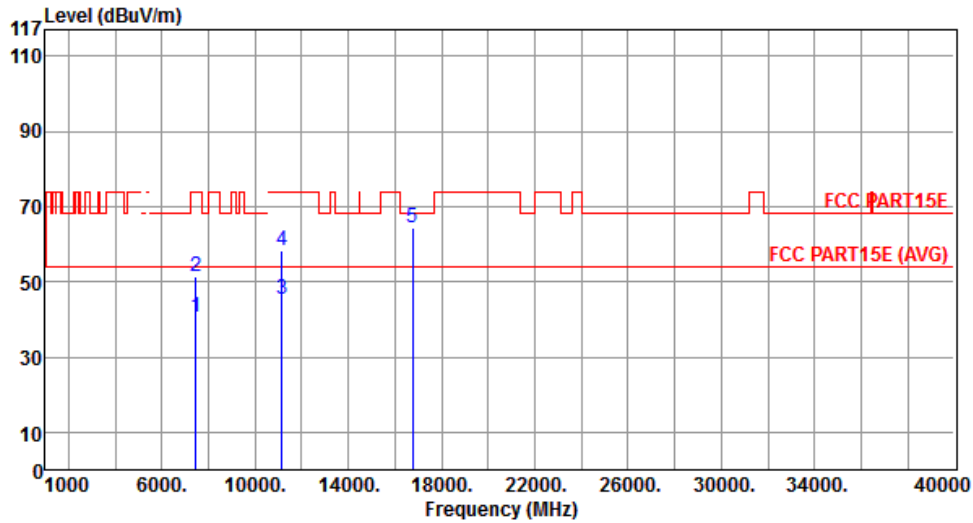

	Freq. MHz	Emission level dBuV/m	Limit dBuV/m	Margin dB	SA reading dBuV	Factor dB	Remark	ANT High cm	Turn Table deg
1	7440.00	40.74	54.00	-13.26	31.15	9.59	Average	---	---
2	7440.00	51.52	74.00	-22.48	41.93	9.59	Peak	---	---
3	11160.00	45.30	54.00	-8.70	30.13	15.17	Average	---	---
4	11160.00	58.14	74.00	-15.86	42.97	15.17	Peak	---	---
5	16740.00	64.23	68.20	-3.97	47.59	16.64	Peak	---	---

Note 1: Emission Level (dBuV/m) = SA Reading (dBuV/m) + Factor\* (dB)

\*Factor includes antenna factor, cable loss and amplifier gain

Note 2: Margin (dB) = Emission level (dBuV/m) – Limit (dBuV/m).

<b>Modulation</b>	VHT20	<b>Test Freq. (MHz)</b>	5700
<b>Polarization</b>	Horizontal		

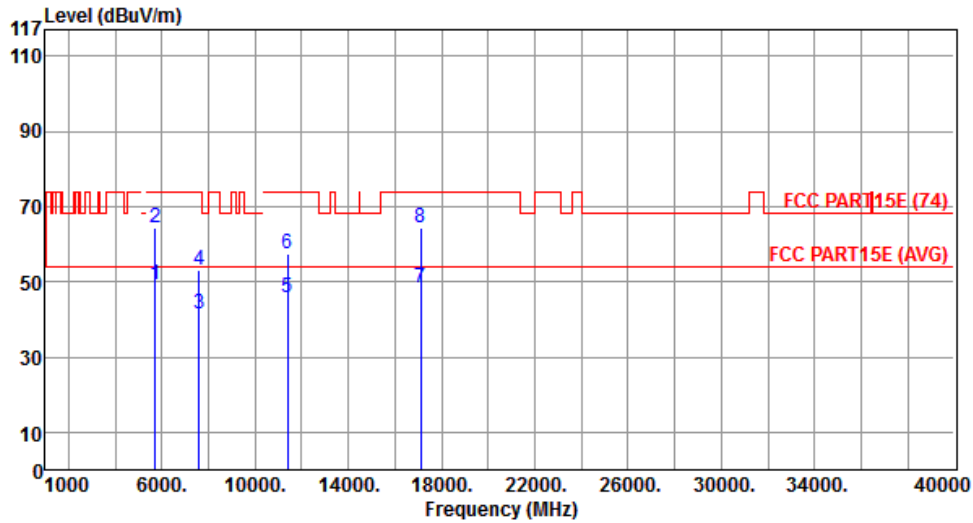

	Freq. MHz	Emission level dBuV/m	Limit dBuV/m	Margin dB	SA reading dBuV	Factor dB	Remark	ANT High cm	Turn Table deg
1	5725.00	49.38	54.00	-4.62	43.80	5.58	Average	---	---
2	5725.00	64.44	74.00	-9.56	58.86	5.58	Peak	---	---
3	7600.00	41.37	54.00	-12.63	31.06	10.31	Average	---	---
4	7600.00	53.15	74.00	-20.85	42.84	10.31	Peak	---	---
5	11400.00	45.70	54.00	-8.30	30.96	14.74	Average	---	---
6	11400.00	57.61	74.00	-16.39	42.87	14.74	Peak	---	---
7	17100.00	48.54	54.00	-5.46	30.84	17.70	Average	---	---
8	17100.00	64.38	74.00	-9.62	46.68	17.70	Peak	---	---

Note 1: Emission Level (dBuV/m) = SA Reading (dBuV/m) + Factor\* (dB)

\*Factor includes antenna factor , cable loss and amplifier gain

Note 2: Margin (dB) = Emission level (dBuV/m) – Limit (dBuV/m).

<b>Modulation</b>	VHT20	<b>Test Freq. (MHz)</b>	5700
<b>Polarization</b>	Vertical		

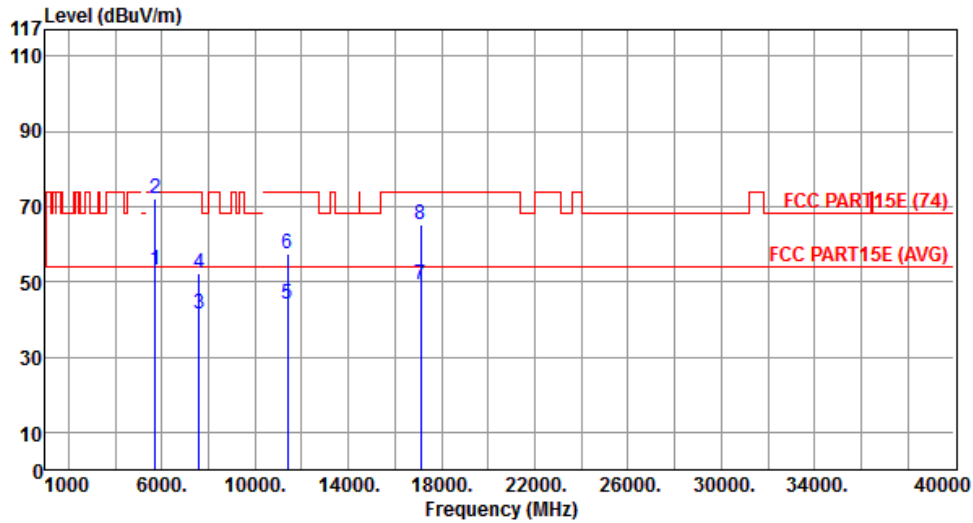

	Freq. MHz	Emission level dBuV/m	Limit dBuV/m	Margin dB	SA reading dBuV	Factor dB	Remark	ANT High cm	Turn Table deg
1	5725.00	52.95	54.00	-1.05	47.37	5.58	Average	---	---
2	5725.00	72.28	74.00	-1.72	66.70	5.58	Peak	---	---
3	7600.00	41.56	54.00	-12.44	31.25	10.31	Average	---	---
4	7600.00	52.30	74.00	-21.70	41.99	10.31	Peak	---	---
5	11400.00	44.09	54.00	-9.91	29.35	14.74	Average	---	---
6	11400.00	57.55	74.00	-16.45	42.81	14.74	Peak	---	---
7	17100.00	49.29	54.00	-4.71	31.59	17.70	Average	---	---
8	17100.00	65.36	74.00	-8.64	47.66	17.70	Peak	---	---

Note 1: Emission Level (dBuV/m) = SA Reading (dBuV/m) + Factor\* (dB)

\*Factor includes antenna factor , cable loss and amplifier gain

Note 2: Margin (dB) = Emission level (dBuV/m) – Limit (dBuV/m).

<b>Modulation</b>	VHT20	<b>Test Freq. (MHz)</b>	5720
<b>Polarization</b>	Horizontal		

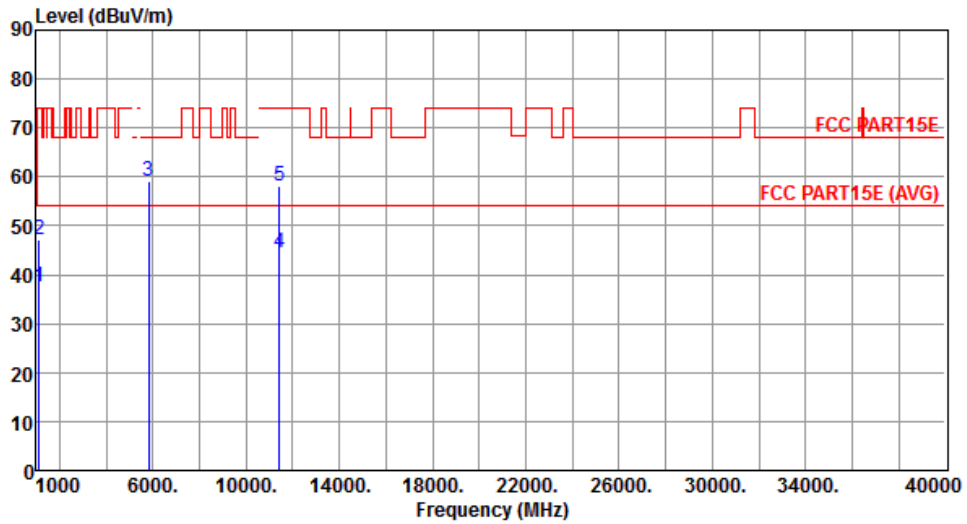

	Freq. MHz	Emission level dBuV/m	Limit dBuV/m	Margin dB	SA reading dBuV	Factor dB	Remark	ANT High cm	Turn Table deg
1	1125.00	37.67	54.00	-16.33	47.18	-9.51	Average	---	---
2	1125.00	47.15	74.00	-26.85	56.66	-9.51	Peak	---	---
3	5825.00	59.26	68.20	-8.94	53.64	5.62	Peak	---	---
4	11440.00	44.62	54.00	-9.38	29.96	14.66	Average	---	---
5	11440.00	58.15	74.00	-15.85	43.49	14.66	Peak	---	---

Note 1: Emission Level (dBuV/m) = SA Reading (dBuV/m) + Factor\* (dB)

\*Factor includes antenna factor , cable loss and amplifier gain

Note 2: Margin (dB) = Emission level (dBuV/m) – Limit (dBuV/m).

<b>Modulation</b>	VHT20	<b>Test Freq. (MHz)</b>	5720
<b>Polarization</b>	Vertical		

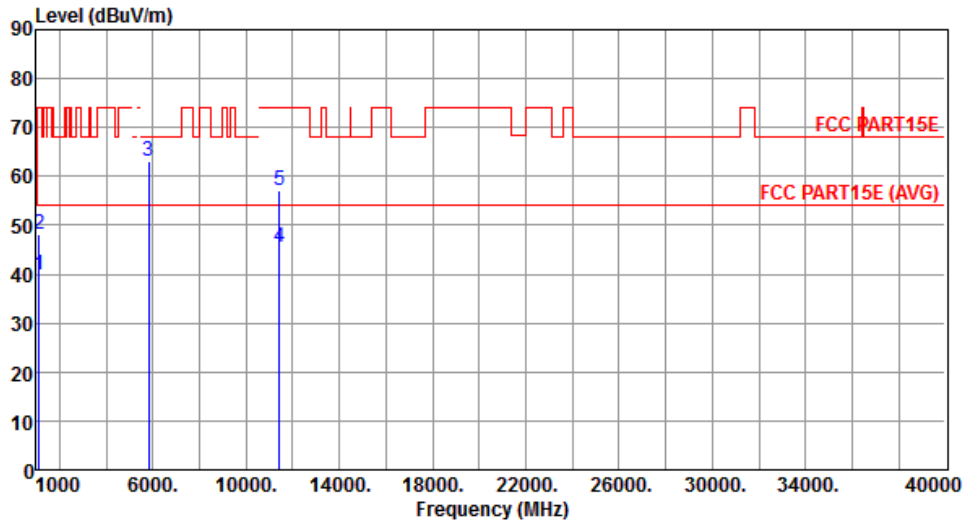

	Freq. MHz	Emission level dBuV/m	Limit dBuV/m	Margin dB	SA reading dBuV	Factor dB	Remark	ANT High cm	Turn Table deg
1	1125.00	39.81	54.00	-14.19	49.32	-9.51	Average	---	---
2	1125.00	48.15	74.00	-25.85	57.66	-9.51	Peak	---	---
3	5825.00	63.09	68.20	-5.11	57.47	5.62	Peak	---	---
4	11440.00	45.52	54.00	-8.48	30.86	14.66	Average	---	---
5	11440.00	57.19	74.00	-16.81	42.53	14.66	Peak	---	---

Note 1: Emission Level (dBuV/m) = SA Reading (dBuV/m) + Factor\* (dB)

\*Factor includes antenna factor , cable loss and amplifier gain

Note 2: Margin (dB) = Emission level (dBuV/m) – Limit (dBuV/m).

### 3.6.7 Transmitter Radiated Unwanted Emissions (Above 1GHz) for VHT40

<b>Modulation</b>	VHT40	<b>Test Freq. (MHz)</b>	5190
<b>Polarization</b>	Horizontal		

  

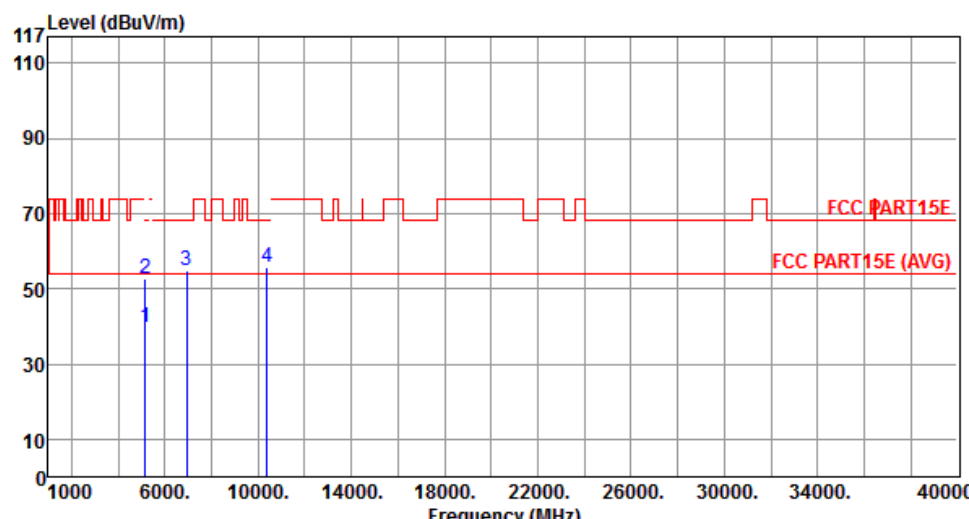

	Freq. MHz	Emission level dBuV/m	Limit dBuV/m	Margin dB	SA reading dBuV	Factor dB	Remark	ANT High cm	Turn Table deg
1	5150.00	39.68	54.00	-14.32	34.12	5.56	Average	---	---
2	5150.00	52.69	74.00	-21.31	47.13	5.56	Peak	---	---
3	6920.00	54.80	68.20	-13.40	46.69	8.11	Peak	---	---
4	10380.00	55.84	68.20	-12.36	40.73	15.11	Peak	---	---

Note 1: Emission Level (dBuV/m) = SA Reading (dBuV/m) + Factor\* (dB)  
\*Factor includes antenna factor , cable loss and amplifier gain  
Note 2: Margin (dB) = Emission level (dBuV/m) – Limit (dBuV/m).

<b>Modulation</b>	VHT40	<b>Test Freq. (MHz)</b>	5190
<b>Polarization</b>	Vertical		

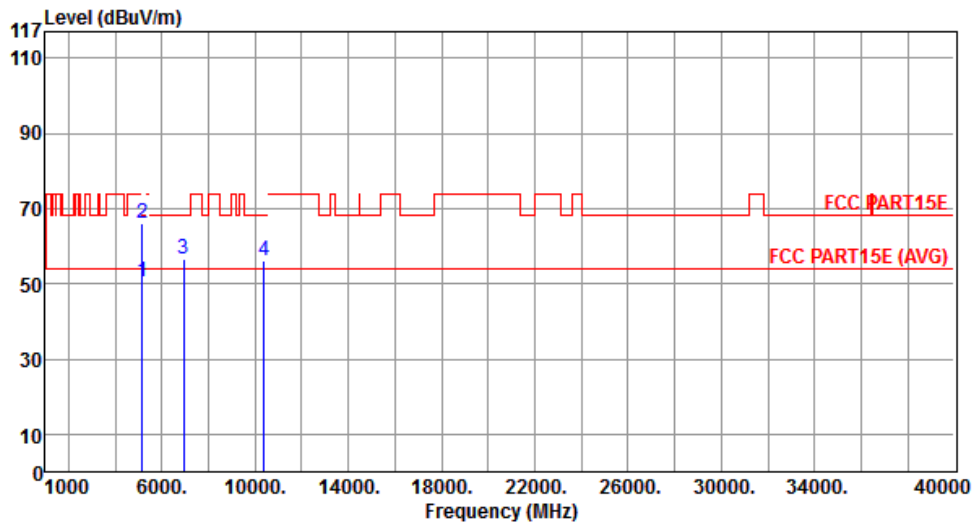

	Freq. MHz	Emission level dBuV/m	Limit dBuV/m	Margin dB	SA reading dBuV	Factor dB	Remark	ANT High cm	Turn Table deg
1	5150.00	50.36	54.00	-3.64	44.80	5.56	Average	---	---
2	5150.00	66.24	74.00	-7.76	60.68	5.56	Peak	---	---
3	6920.00	56.56	68.20	-11.64	48.45	8.11	Peak	---	---
4	10380.00	56.06	68.20	-12.14	40.95	15.11	Peak	---	---

Note 1: Emission Level (dBuV/m) = SA Reading (dBuV/m) + Factor\* (dB)

\*Factor includes antenna factor , cable loss and amplifier gain

Note 2: Margin (dB) = Emission level (dBuV/m) – Limit (dBuV/m).

<b>Modulation</b>	VHT40	<b>Test Freq. (MHz)</b>	5230
<b>Polarization</b>	Horizontal		

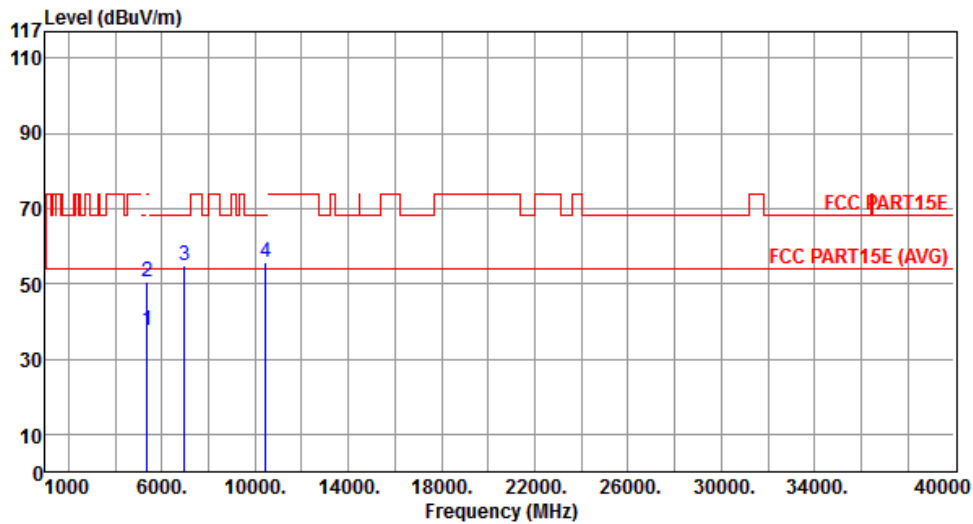

	Freq. MHz	Emission level dBuV/m	Limit dBuV/m	Margin dB	SA reading dBuV	Factor dB	Remark	ANT High cm	Turn Table deg
1	5350.00	37.48	54.00	-16.52	31.77	5.71	Average	---	---
2	5350.00	50.72	74.00	-23.28	45.01	5.71	Peak	---	---
3	6973.33	54.65	68.20	-13.55	46.52	8.13	Peak	---	---
4	10460.00	55.69	68.20	-12.51	40.48	15.21	Peak	---	---

Note 1: Emission Level (dBuV/m) = SA Reading (dBuV/m) + Factor\* (dB)

\*Factor includes antenna factor , cable loss and amplifier gain

Note 2: Margin (dB) = Emission level (dBuV/m) – Limit (dBuV/m).



<b>Modulation</b>	VHT40	<b>Test Freq. (MHz)</b>	5230
<b>Polarization</b>	Vertical		

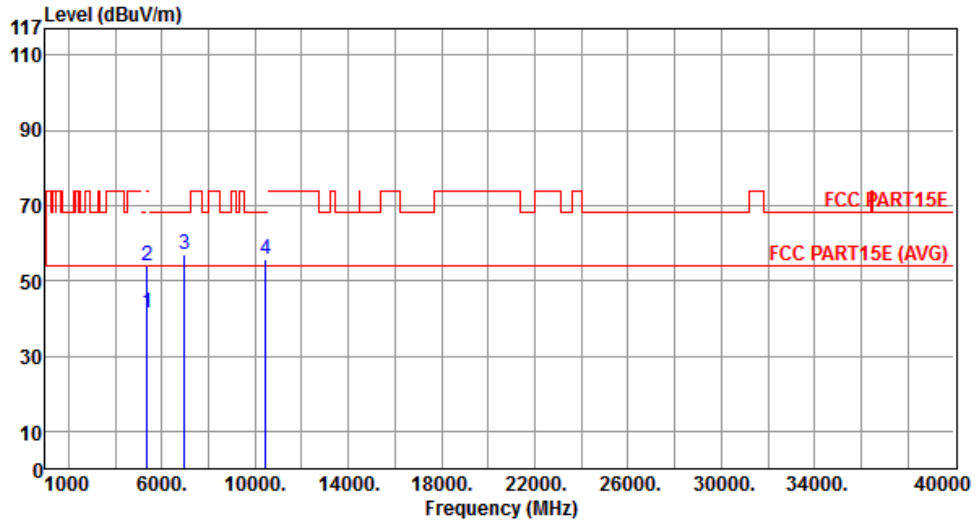

	Freq. MHz	Emission level dBuV/m	Limit dBuV/m	Margin dB	SA reading dBuV	Factor dB	Remark	ANT High cm	Turn Table deg
1	5350.00	41.25	54.00	-12.75	35.54	5.71	Average	---	---
2	5350.00	54.08	74.00	-19.92	48.37	5.71	Peak	---	---
3	6973.33	57.04	68.20	-11.16	48.91	8.13	Peak	---	---
4	10460.00	55.89	68.20	-12.31	40.68	15.21	Peak	---	---

Note 1: Emission Level (dBuV/m) = SA Reading (dBuV/m) + Factor\* (dB)

\*Factor includes antenna factor , cable loss and amplifier gain

Note 2: Margin (dB) = Emission level (dBuV/m) – Limit (dBuV/m).

<b>Modulation</b>	VHT40	<b>Test Freq. (MHz)</b>	5270
<b>Polarization</b>	Horizontal		

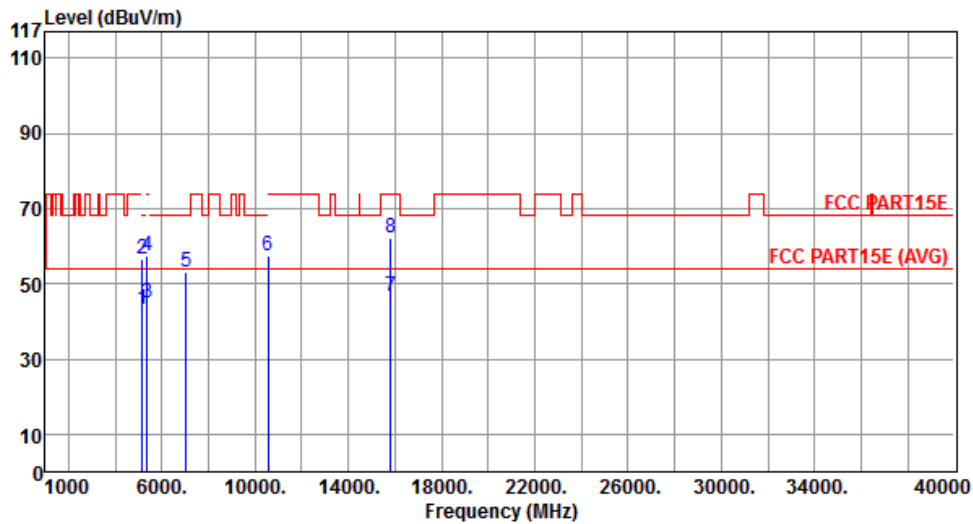

	Freq. MHz	Emission level dBuV/m	Limit dBuV/m	Margin dB	SA reading dBuV	Factor dB	Remark	ANT High cm	Turn Table deg
1	5150.00	43.14	54.00	-10.86	37.58	5.56	Average	---	---
2	5150.00	56.55	74.00	-17.45	50.99	5.56	Peak	---	---
3	5350.00	44.89	54.00	-9.11	39.18	5.71	Average	---	---
4	5350.00	57.59	74.00	-16.41	51.88	5.71	Peak	---	---
5	7026.66	53.03	68.20	-15.17	44.74	8.29	Peak	---	---
6	10540.00	57.43	68.20	-10.77	42.15	15.28	Peak	---	---
7	15810.00	46.66	54.00	-7.34	32.53	14.13	Average	---	---
8	15810.00	62.29	74.00	-11.71	48.16	14.13	Peak	---	---

Note 1: Emission Level (dBuV/m) = SA Reading (dBuV/m) + Factor\* (dB)

\*Factor includes antenna factor , cable loss and amplifier gain

Note 2: Margin (dB) = Emission level (dBuV/m) – Limit (dBuV/m).

<b>Modulation</b>	VHT40	<b>Test Freq. (MHz)</b>	5270
<b>Polarization</b>	Vertical		

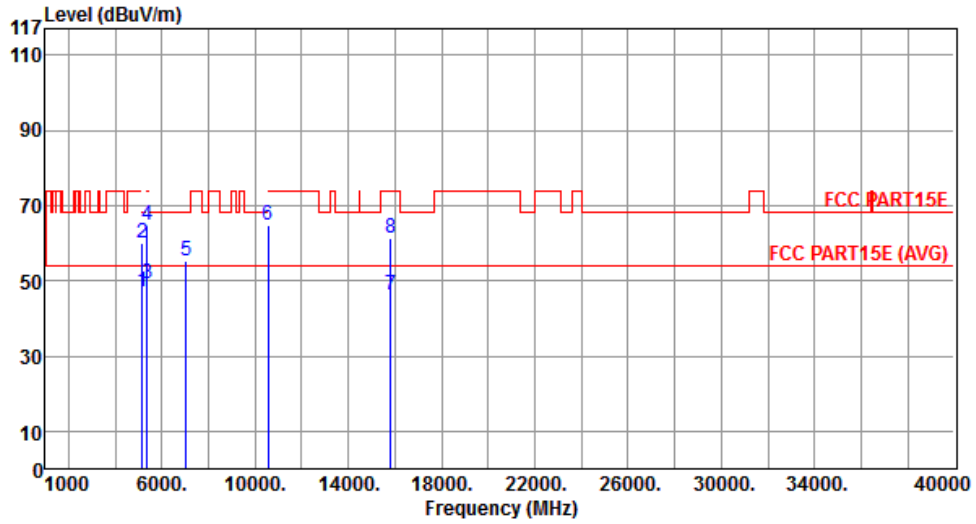

	Freq. MHz	Emission level dBuV/m	Limit dBuV/m	Margin dB	SA reading dBuV	Factor dB	Remark	ANT High cm	Turn Table deg
1	5150.00	46.99	54.00	-7.01	41.43	5.56	Average	---	---
2	5150.00	59.93	74.00	-14.07	54.37	5.56	Peak	---	---
3	5350.00	49.34	54.00	-4.66	43.63	5.71	Average	---	---
4	5350.00	64.63	74.00	-9.37	58.92	5.71	Peak	---	---
5	7026.66	55.38	68.20	-12.82	47.09	8.29	Peak	---	---
6	10540.00	64.57	68.20	-3.63	49.29	15.28	Peak	---	---
7	15810.00	46.31	54.00	-7.69	32.18	14.13	Average	---	---
8	15810.00	61.14	74.00	-12.86	47.01	14.13	Peak	---	---

Note 1: Emission Level (dBuV/m) = SA Reading (dBuV/m) + Factor\* (dB)

\*Factor includes antenna factor , cable loss and amplifier gain

Note 2: Margin (dB) = Emission level (dBuV/m) – Limit (dBuV/m).

<b>Modulation</b>	VHT40	<b>Test Freq. (MHz)</b>	5310
<b>Polarization</b>	Horizontal		

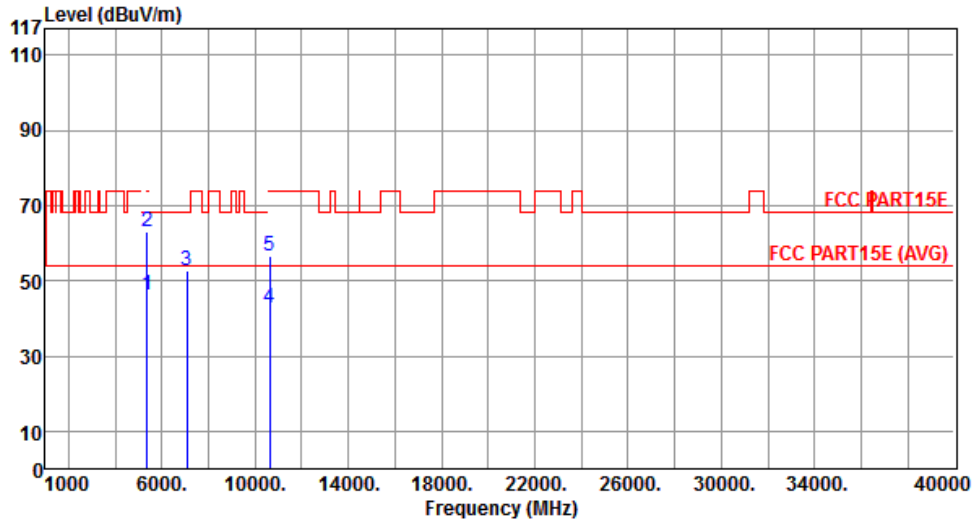

	Freq. MHz	Emission level dBuV/m	Limit dBuV/m	Margin dB	SA reading dBuV	Factor dB	Remark	ANT High cm	Turn Table deg
1	5350.00	46.08	54.00	-7.92	40.37	5.71	Average	---	---
2	5350.00	63.16	74.00	-10.84	57.45	5.71	Peak	---	---
3	7080.00	52.48	68.20	-15.72	43.89	8.59	Peak	---	---
4	10620.00	42.81	54.00	-11.19	27.50	15.31	Average	---	---
5	10620.00	56.41	74.00	-17.59	41.10	15.31	Peak	---	---

Note 1: Emission Level (dBuV/m) = SA Reading (dBuV/m) + Factor\* (dB)

\*Factor includes antenna factor , cable loss and amplifier gain

Note 2: Margin (dB) = Emission level (dBuV/m) – Limit (dBuV/m).

<b>Modulation</b>	VHT40	<b>Test Freq. (MHz)</b>	5310
<b>Polarization</b>	Vertical		

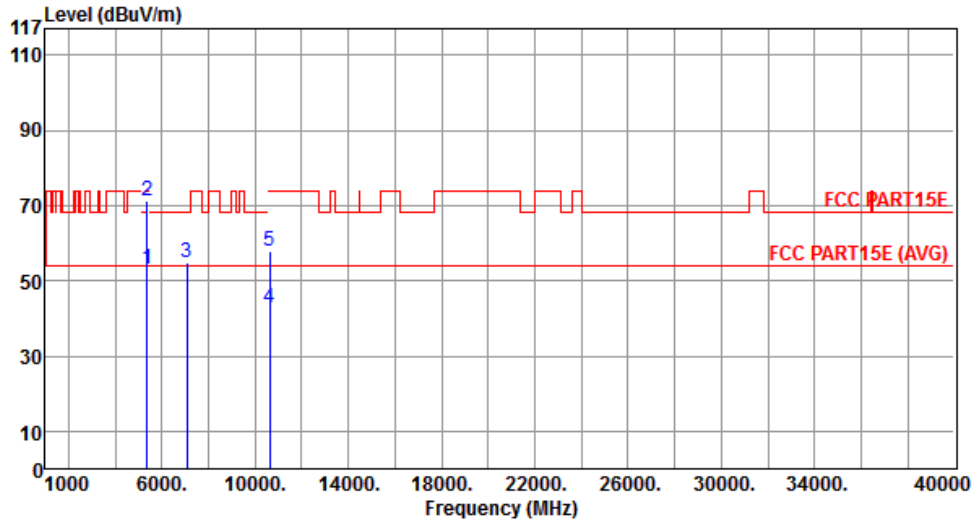

	Freq. MHz	Emission level dBuV/m	Limit dBuV/m	Margin dB	SA reading dBuV	Factor dB	Remark	ANT High cm	Turn Table deg
1	5350.00	52.90	54.00	-1.10	47.19	5.71	Average	---	---
2	5350.00	71.19	74.00	-2.81	65.48	5.71	Peak	---	---
3	7080.00	54.92	68.20	-13.28	46.33	8.59	Peak	---	---
4	10620.00	42.75	54.00	-11.25	27.44	15.31	Average	---	---
5	10620.00	58.05	74.00	-15.95	42.74	15.31	Peak	---	---

Note 1: Emission Level (dBuV/m) = SA Reading (dBuV/m) + Factor\* (dB)

\*Factor includes antenna factor , cable loss and amplifier gain

Note 2: Margin (dB) = Emission level (dBuV/m) – Limit (dBuV/m).

<b>Modulation</b>	VHT40	<b>Test Freq. (MHz)</b>	5510
<b>Polarization</b>	Horizontal		

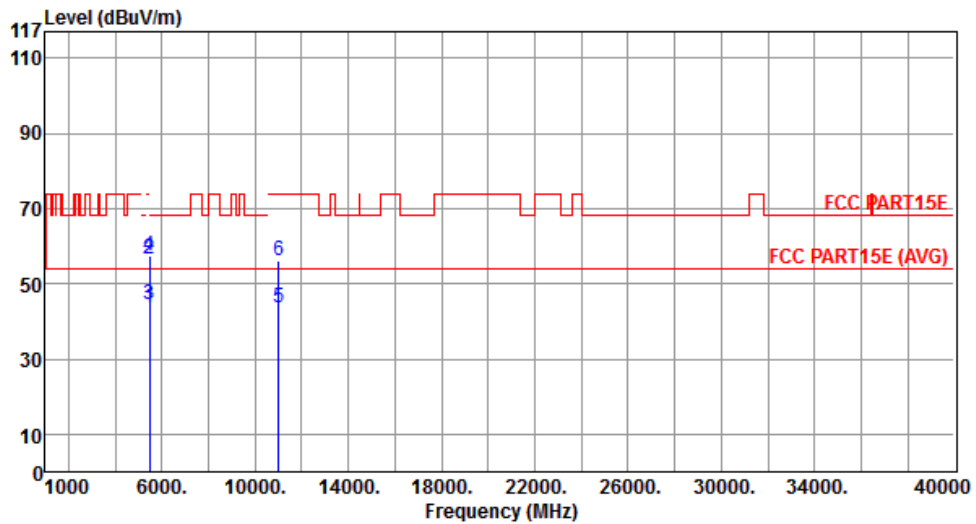

	Freq. MHz	Emission level dBuV/m	Limit dBuV/m	Margin dB	SA reading dBuV	Factor dB	Remark	ANT High cm	Turn Table deg
1	5460.00	43.43	54.00	-10.57	37.75	5.68	Average	---	---
2	5460.00	56.53	74.00	-17.47	50.85	5.68	Peak	---	---
3	5470.00	44.62	54.00	-9.38	38.96	5.66	Average	---	---
4	5470.00	57.42	68.20	-10.78	51.76	5.66	Peak	---	---
5	11020.00	43.55	54.00	-10.45	28.13	15.42	Average	---	---
6	11020.00	56.09	74.00	-17.91	40.67	15.42	Peak	---	---

Note 1: Emission Level (dBuV/m) = SA Reading (dBuV/m) + Factor\* (dB)

\*Factor includes antenna factor , cable loss and amplifier gain

Note 2: Margin (dB) = Emission level (dBuV/m) – Limit (dBuV/m).

<b>Modulation</b>	VHT40	<b>Test Freq. (MHz)</b>	5510
<b>Polarization</b>	Vertical		

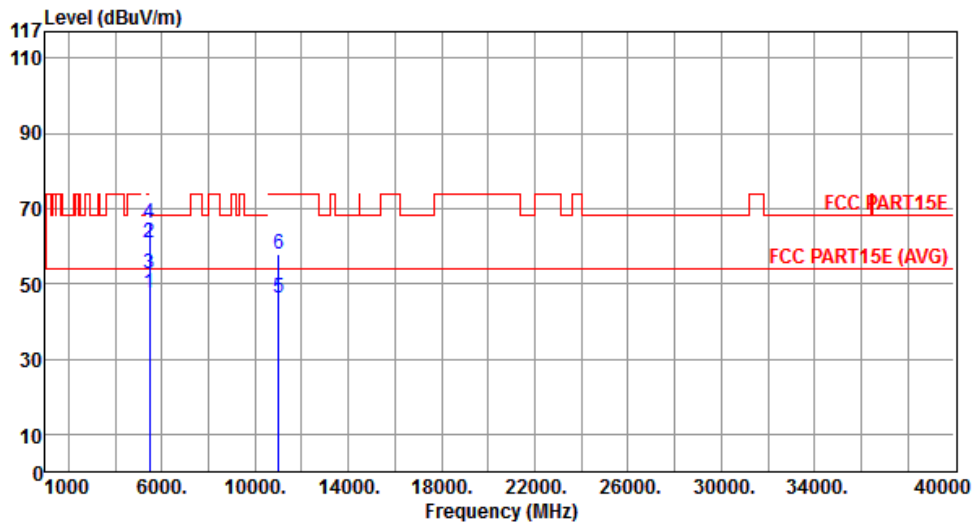

	Freq. MHz	Emission level dBuV/m	Limit dBuV/m	Margin dB	SA reading dBuV	Factor dB	Remark	ANT High cm	Turn Table deg
1	5460.00	47.57	54.00	-6.43	41.89	5.68	Average	---	---
2	5460.00	61.03	74.00	-12.97	55.35	5.68	Peak	---	---
3	5470.00	52.58	54.00	-1.42	46.92	5.66	Average	---	---
4	5470.00	66.01	68.20	-2.19	60.35	5.66	Peak	---	---
5	11020.00	45.99	54.00	-8.01	30.57	15.42	Average	---	---
6	11020.00	57.70	74.00	-16.30	42.28	15.42	Peak	---	---

Note 1: Emission Level (dBuV/m) = SA Reading (dBuV/m) + Factor\* (dB)

\*Factor includes antenna factor , cable loss and amplifier gain

Note 2: Margin (dB) = Emission level (dBuV/m) – Limit (dBuV/m).

<b>Modulation</b>	VHT40	<b>Test Freq. (MHz)</b>	5550
<b>Polarization</b>	Horizontal		

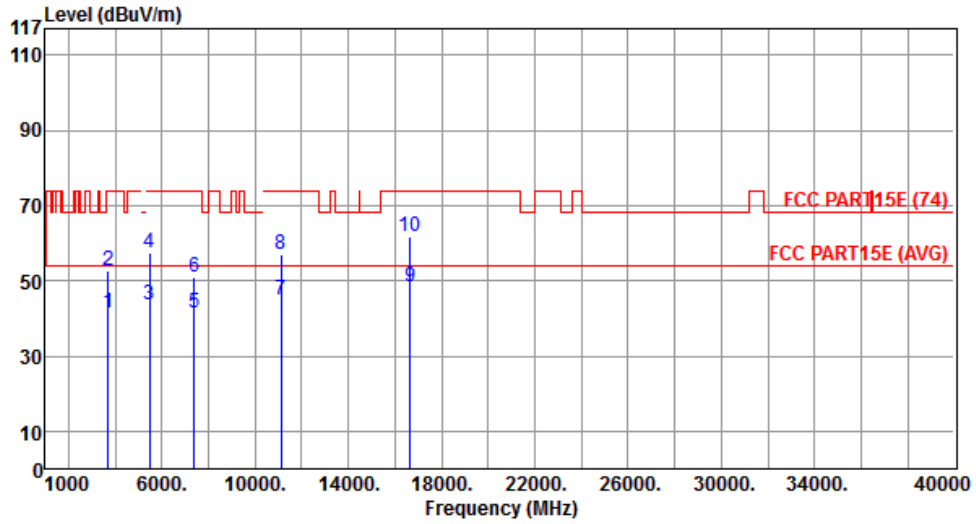

	Freq. MHz	Emission level dBuV/m	Limit dBuV/m	Margin dB	SA reading dBuV	Factor dB	Remark	ANT High cm	Turn Table deg
1	3700.00	41.64	54.00	-12.36	41.19	0.45	Average	---	---
2	3700.00	52.57	74.00	-21.43	52.12	0.45	Peak	---	---
3	5470.00	43.49	54.00	-10.51	37.83	5.66	Average	---	---
4	5470.00	57.27	74.00	-16.73	51.61	5.66	Peak	---	---
5	7400.00	41.66	54.00	-12.34	32.26	9.40	Average	---	---
6	7400.00	51.02	74.00	-22.98	41.62	9.40	Peak	---	---
7	11100.00	44.73	54.00	-9.27	29.46	15.27	Average	---	---
8	11100.00	56.84	74.00	-17.16	41.57	15.27	Peak	---	---
9	16650.00	48.56	54.00	-5.44	32.13	16.43	Average	---	---
10	16650.00	61.71	74.00	-12.29	45.28	16.43	Peak	---	---

Note 1: Emission Level (dBuV/m) = SA Reading (dBuV/m) + Factor\* (dB)

\*Factor includes antenna factor , cable loss and amplifier gain

Note 2: Margin (dB) = Emission level (dBuV/m) – Limit (dBuV/m).



<b>Modulation</b>	VHT40	<b>Test Freq. (MHz)</b>	5550
<b>Polarization</b>	Vertical		

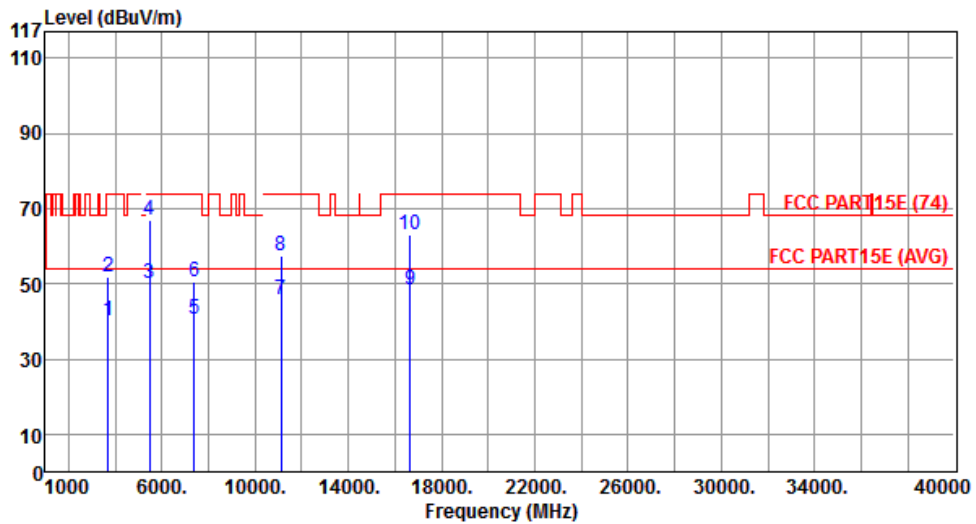

	Freq. MHz	Emission level dBuV/m	Limit dBuV/m	Margin dB	SA reading dBuV	Factor dB	Remark	ANT High cm	Turn Table deg
1	3700.00	40.03	54.00	-13.97	39.58	0.45	Average	---	---
2	3700.00	52.01	74.00	-21.99	51.56	0.45	Peak	---	---
3	5470.00	49.89	54.00	-4.11	44.23	5.66	Average	---	---
4	5470.00	66.75	74.00	-7.25	61.09	5.66	Peak	---	---
5	7400.00	40.69	54.00	-13.31	31.29	9.40	Average	---	---
6	7400.00	50.71	74.00	-23.29	41.31	9.40	Peak	---	---
7	11100.00	45.56	54.00	-8.44	30.29	15.27	Average	---	---
8	11100.00	57.61	74.00	-16.39	42.34	15.27	Peak	---	---
9	16650.00	48.30	54.00	-5.70	31.87	16.43	Average	---	---
10	16650.00	63.15	74.00	-10.85	46.72	16.43	Peak	---	---

Note 1: Emission Level (dBuV/m) = SA Reading (dBuV/m) + Factor\* (dB)

\*Factor includes antenna factor , cable loss and amplifier gain

Note 2: Margin (dB) = Emission level (dBuV/m) – Limit (dBuV/m).

<b>Modulation</b>	VHT40	<b>Test Freq. (MHz)</b>	5670
<b>Polarization</b>	Horizontal		

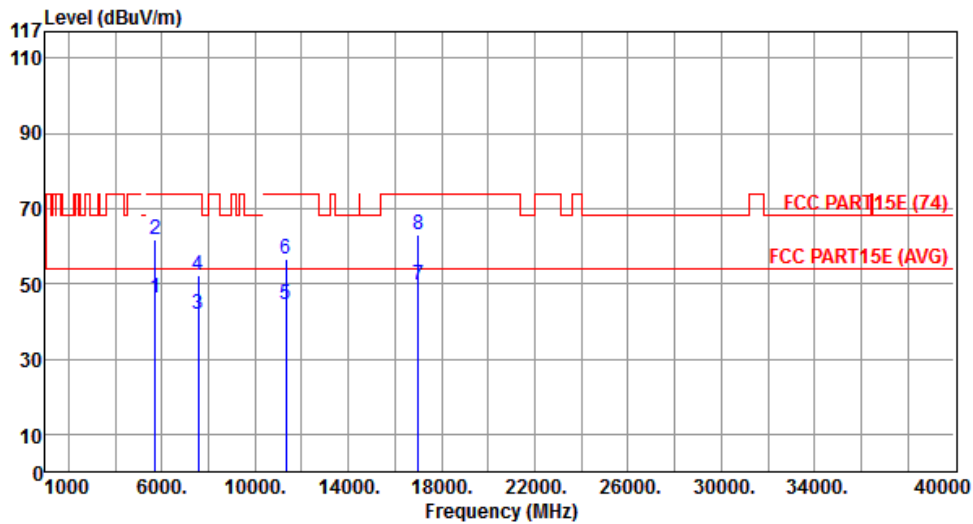

	Freq. MHz	Emission level dBuV/m	Limit dBuV/m	Margin dB	SA reading dBuV	Factor dB	Remark	ANT High cm	Turn Table deg
1	5725.00	46.20	54.00	-7.80	40.62	5.58	Average	---	---
2	5725.00	61.90	74.00	-12.10	56.32	5.58	Peak	---	---
3	7560.00	42.05	54.00	-11.95	31.92	10.13	Average	---	---
4	7560.00	52.28	74.00	-21.72	42.15	10.13	Peak	---	---
5	11340.00	44.42	54.00	-9.58	29.58	14.84	Average	---	---
6	11340.00	56.69	74.00	-17.31	41.85	14.84	Peak	---	---
7	17010.00	49.81	54.00	-4.19	32.48	17.33	Average	---	---
8	17010.00	62.98	74.00	-11.02	45.65	17.33	Peak	---	---

Note 1: Emission Level (dBuV/m) = SA Reading (dBuV/m) + Factor\* (dB)

\*Factor includes antenna factor , cable loss and amplifier gain

Note 2: Margin (dB) = Emission level (dBuV/m) – Limit (dBuV/m).

<b>Modulation</b>	VHT40	<b>Test Freq. (MHz)</b>	5670
<b>Polarization</b>	Vertical		

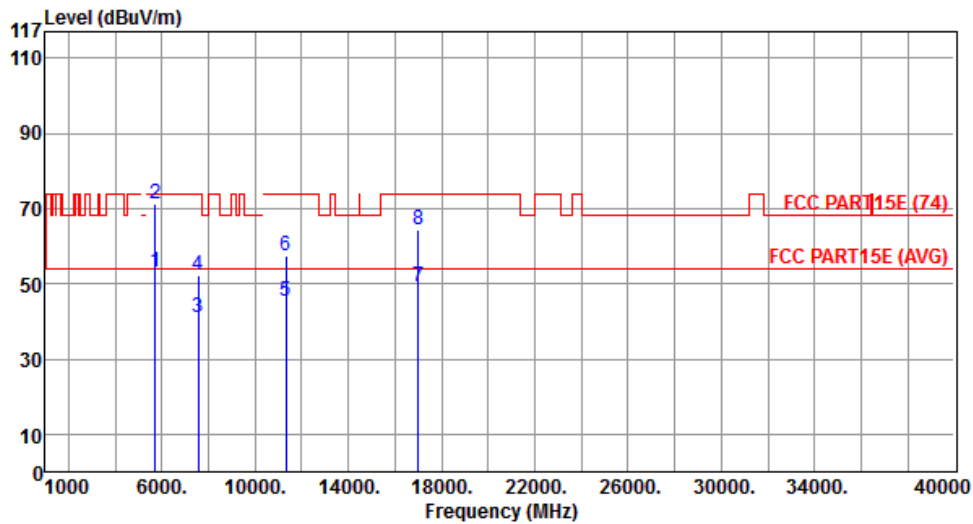

	Freq. MHz	Emission level dBuV/m	Limit dBuV/m	Margin dB	SA reading dBuV	Factor dB	Remark	ANT High cm	Turn Table deg
1	5725.00	52.98	54.00	-1.02	47.40	5.58	Average	---	---
2	5725.00	71.04	74.00	-2.96	65.46	5.58	Peak	---	---
3	7560.00	41.10	54.00	-12.90	30.97	10.13	Average	---	---
4	7560.00	52.40	74.00	-21.60	42.27	10.13	Peak	---	---
5	11340.00	45.41	54.00	-8.59	30.57	14.84	Average	---	---
6	11340.00	57.42	74.00	-16.58	42.58	14.84	Peak	---	---
7	17010.00	49.37	54.00	-4.63	32.04	17.33	Average	---	---
8	17010.00	64.27	74.00	-9.73	46.94	17.33	Peak	---	---

Note 1: Emission Level (dBuV/m) = SA Reading (dBuV/m) + Factor\* (dB)

\*Factor includes antenna factor , cable loss and amplifier gain

Note 2: Margin (dB) = Emission level (dBuV/m) – Limit (dBuV/m).

<b>Modulation</b>	VHT40	<b>Test Freq. (MHz)</b>	5710
<b>Polarization</b>	Horizontal		

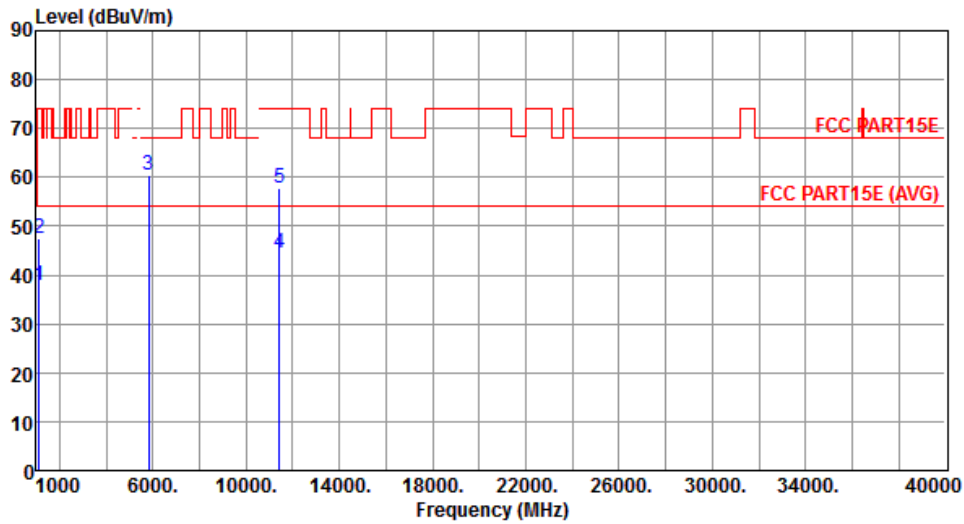

	Freq. MHz	Emission level dBuV/m	Limit dBuV/m	Margin dB	SA reading dBuV	Factor dB	Remark	ANT High cm	Turn Table deg
1	1125.00	37.94	54.00	-16.06	47.45	-9.51	Average	---	---
2	1125.00	47.56	74.00	-26.44	57.07	-9.51	Peak	---	---
3	5825.00	60.49	68.20	-7.71	54.87	5.62	Peak	---	---
4	11420.00	44.54	54.00	-9.46	29.84	14.70	Average	---	---
5	11420.00	57.71	74.00	-16.29	43.01	14.70	Peak	---	---

Note 1: Emission Level (dBuV/m) = SA Reading (dBuV/m) + Factor\* (dB)

\*Factor includes antenna factor , cable loss and amplifier gain

Note 2: Margin (dB) = Emission level (dBuV/m) – Limit (dBuV/m).

<b>Modulation</b>	VHT40	<b>Test Freq. (MHz)</b>	5710
<b>Polarization</b>	Vertical		

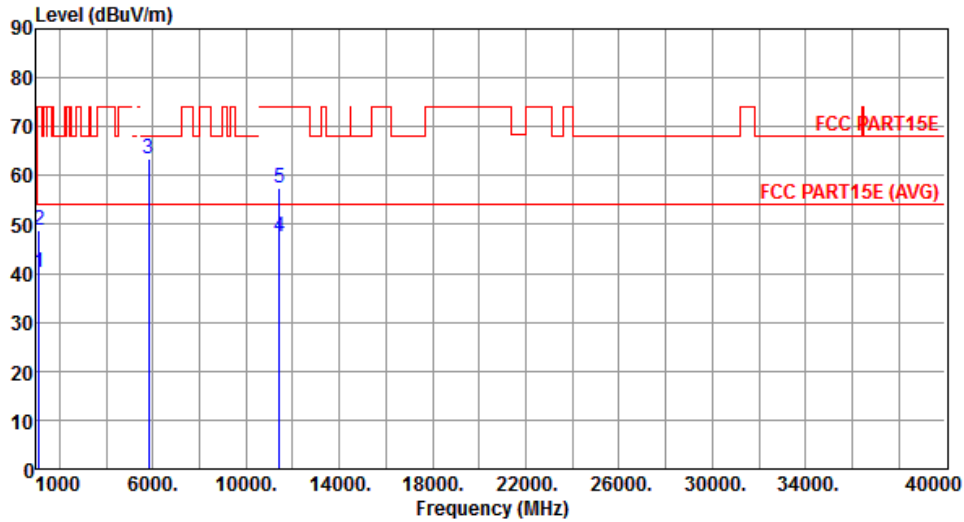

	Freq. MHz	Emission level dBuV/m	Limit dBuV/m	Margin dB	SA reading dBuV	Factor dB	Remark	ANT High cm	Turn Table deg
1	1125.00	40.17	54.00	-13.83	49.68	-9.51	Average	---	---
2	1125.00	48.68	74.00	-25.32	58.19	-9.51	Peak	---	---
3	5825.00	63.52	68.20	-4.68	57.90	5.62	Peak	---	---
4	11420.00	47.39	54.00	-6.61	32.69	14.70	Average	---	---
5	11420.00	57.38	74.00	-16.62	42.68	14.70	Peak	---	---

Note 1: Emission Level (dBuV/m) = SA Reading (dBuV/m) + Factor\* (dB)

\*Factor includes antenna factor , cable loss and amplifier gain

Note 2: Margin (dB) = Emission level (dBuV/m) – Limit (dBuV/m).

### 3.6.8 Transmitter Radiated Unwanted Emissions (Above 1GHz) for VHT80

<b>Modulation</b>	VHT80	<b>Test Freq. (MHz)</b>	5210
<b>Polarization</b>	Horizontal		

  

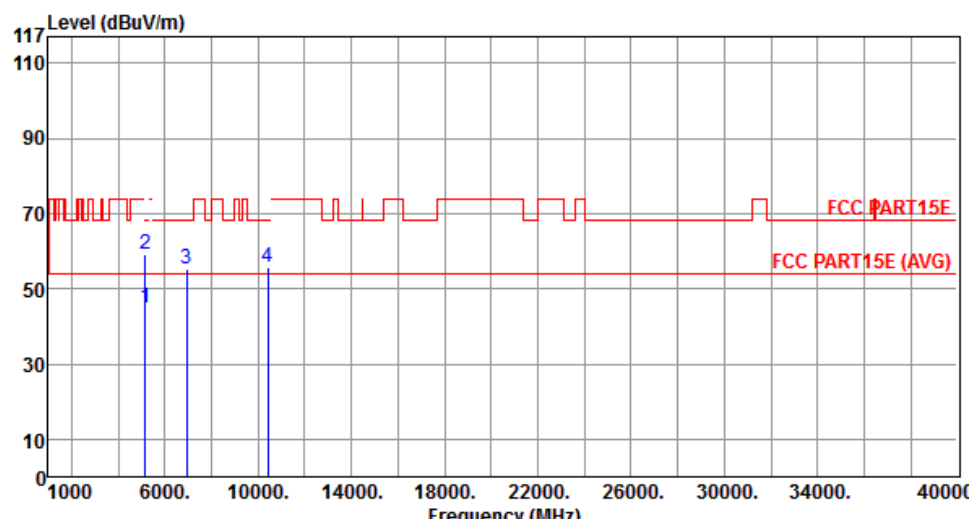

	Freq. MHz	Emission level dBuV/m	Limit dBuV/m	Margin dB	SA reading dBuV	Factor dB	Remark	ANT High cm	Turn Table deg
1	5150.00	45.11	54.00	-8.89	39.55	5.56	Average	---	---
2	5150.00	59.16	74.00	-14.84	53.60	5.56	Peak	---	---
3	6946.66	55.20	68.20	-13.00	47.08	8.12	Peak	---	---
4	10420.00	55.64	68.20	-12.56	40.49	15.15	Peak	---	---

Note 1: Emission Level (dBuV/m) = SA Reading (dBuV/m) + Factor\* (dB)  
\*Factor includes antenna factor , cable loss and amplifier gain  
Note 2: Margin (dB) = Emission level (dBuV/m) – Limit (dBuV/m).

<b>Modulation</b>	VHT80	<b>Test Freq. (MHz)</b>	5210
<b>Polarization</b>	Vertical		

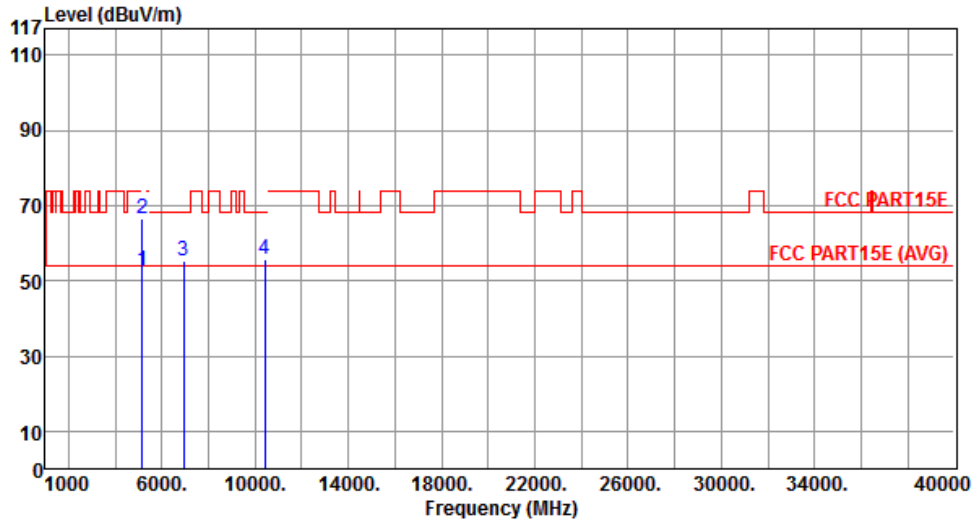

	Freq. MHz	Emission level dBuV/m	Limit dBuV/m	Margin dB	SA reading dBuV	Factor dB	Remark	ANT High cm	Turn Table deg
1	5150.00	52.79	54.00	-1.21	47.23	5.56	Average	---	---
2	5150.00	66.45	74.00	-7.55	60.89	5.56	Peak	---	---
3	6946.66	55.21	68.20	-12.99	47.09	8.12	Peak	---	---
4	10420.00	55.82	68.20	-12.38	40.67	15.15	Peak	---	---

Note 1: Emission Level (dBuV/m) = SA Reading (dBuV/m) + Factor\* (dB)

\*Factor includes antenna factor , cable loss and amplifier gain

Note 2: Margin (dB) = Emission level (dBuV/m) – Limit (dBuV/m).

<b>Modulation</b>	VHT80	<b>Test Freq. (MHz)</b>	5290
<b>Polarization</b>	Horizontal		

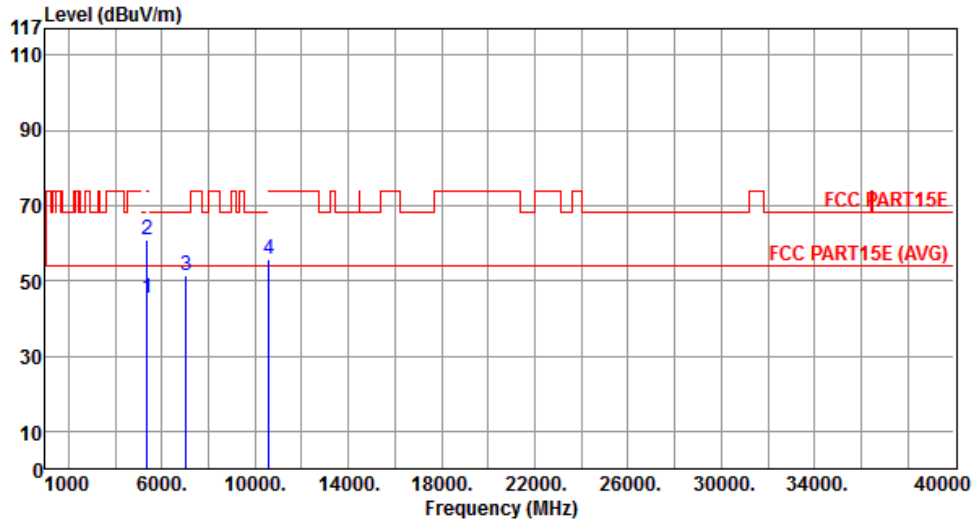

	Freq. MHz	Emission level dBuV/m	Limit dBuV/m	Margin dB	SA reading dBuV	Factor dB	Remark	ANT High cm	Turn Table deg
1	5350.00	45.17	54.00	-8.83	39.46	5.71	Average	---	---
2	5350.00	60.91	74.00	-13.09	55.20	5.71	Peak	---	---
3	7053.33	51.28	68.20	-16.92	42.84	8.44	Peak	---	---
4	10580.00	55.66	68.20	-12.54	40.38	15.28	Peak	---	---

Note 1: Emission Level (dBuV/m) = SA Reading (dBuV/m) + Factor\* (dB)

\*Factor includes antenna factor , cable loss and amplifier gain

Note 2: Margin (dB) = Emission level (dBuV/m) – Limit (dBuV/m).



<b>Modulation</b>	VHT80	<b>Test Freq. (MHz)</b>	5290
<b>Polarization</b>	Vertical		

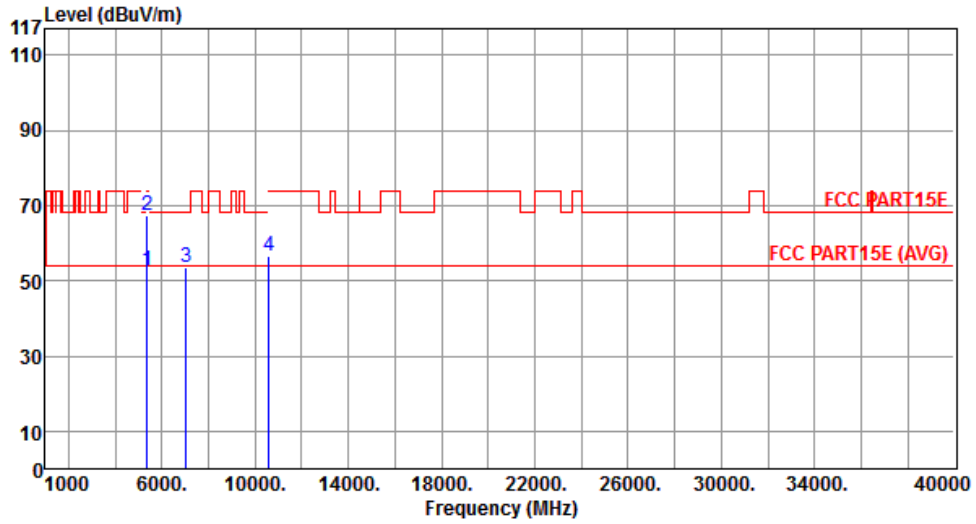

	Freq. MHz	Emission level dBuV/m	Limit dBuV/m	Margin dB	SA reading dBuV	Factor dB	Remark	ANT High cm	Turn Table deg
1	5350.00	52.87	54.00	-1.13	47.16	5.71	Average	---	---
2	5350.00	67.41	74.00	-6.59	61.70	5.71	Peak	---	---
3	7053.33	53.42	68.20	-14.78	44.98	8.44	Peak	---	---
4	10580.00	56.54	68.20	-11.66	41.26	15.28	Peak	---	---

Note 1: Emission Level (dBuV/m) = SA Reading (dBuV/m) + Factor\* (dB)

\*Factor includes antenna factor , cable loss and amplifier gain

Note 2: Margin (dB) = Emission level (dBuV/m) – Limit (dBuV/m).

<b>Modulation</b>	VHT80	<b>Test Freq. (MHz)</b>	5530
<b>Polarization</b>	Horizontal		

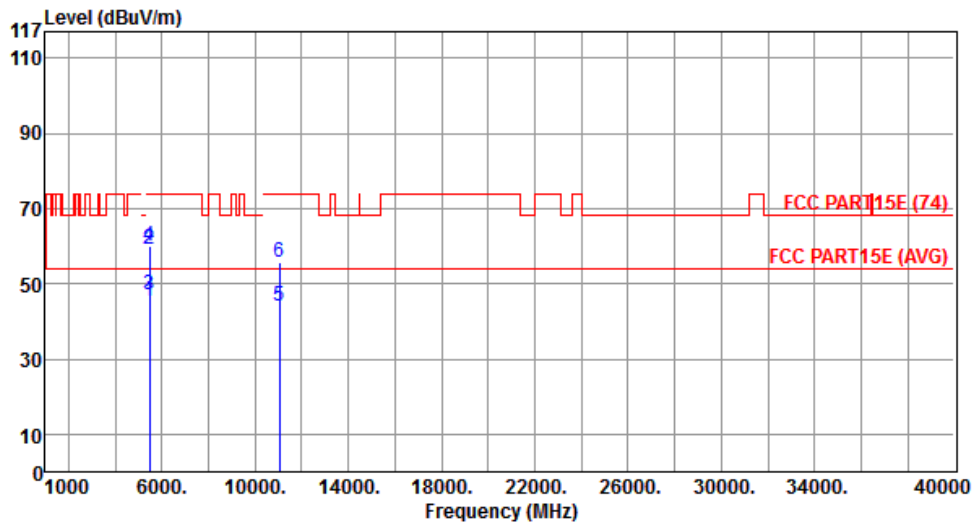

	Freq. MHz	Emission level dBuV/m	Limit dBuV/m	Margin dB	SA reading dBuV	Factor dB	Remark	ANT High cm	Turn Table deg
1	5460.00	45.43	54.00	-8.57	39.75	5.68	Average	---	---
2	5460.00	59.30	74.00	-14.70	53.62	5.68	Peak	---	---
3	5470.00	47.17	54.00	-6.83	41.51	5.66	Average	---	---
4	5470.00	59.96	74.00	-14.04	54.30	5.66	Peak	---	---
5	11060.00	43.83	54.00	-10.17	28.48	15.35	Average	---	---
6	11060.00	55.57	74.00	-18.43	40.22	15.35	Peak	---	---

Note 1: Emission Level (dBuV/m) = SA Reading (dBuV/m) + Factor\* (dB)

\*Factor includes antenna factor , cable loss and amplifier gain

Note 2: Margin (dB) = Emission level (dBuV/m) – Limit (dBuV/m).

<b>Modulation</b>	VHT80	<b>Test Freq. (MHz)</b>	5530
<b>Polarization</b>	Vertical		

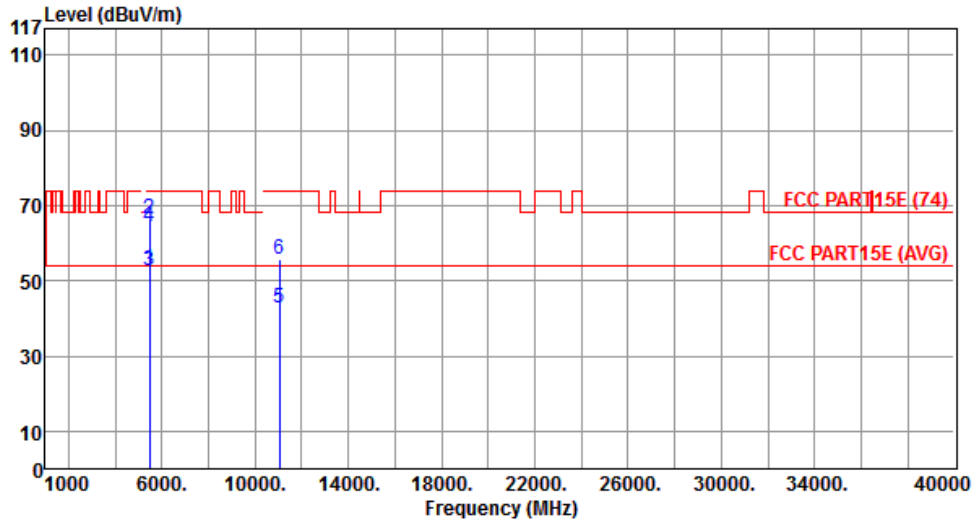

	Freq. MHz	Emission level dBuV/m	Limit dBuV/m	Margin dB	SA reading dBuV	Factor dB	Remark	ANT High cm	Turn Table deg
1	5460.00	52.90	54.00	-1.10	47.22	5.68	Average	---	---
2	5460.00	66.38	74.00	-7.62	60.70	5.68	Peak	---	---
3	5470.00	52.84	54.00	-1.16	47.18	5.66	Average	---	---
4	5470.00	64.30	74.00	-9.70	58.64	5.66	Peak	---	---
5	11060.00	42.87	54.00	-11.13	27.52	15.35	Average	---	---
6	11060.00	55.88	74.00	-18.12	40.53	15.35	Peak	---	---

Note 1: Emission Level (dBuV/m) = SA Reading (dBuV/m) + Factor\* (dB)

\*Factor includes antenna factor , cable loss and amplifier gain

Note 2: Margin (dB) = Emission level (dBuV/m) – Limit (dBuV/m).

<b>Modulation</b>	VHT80	<b>Test Freq. (MHz)</b>	5690
<b>Polarization</b>	Horizontal		

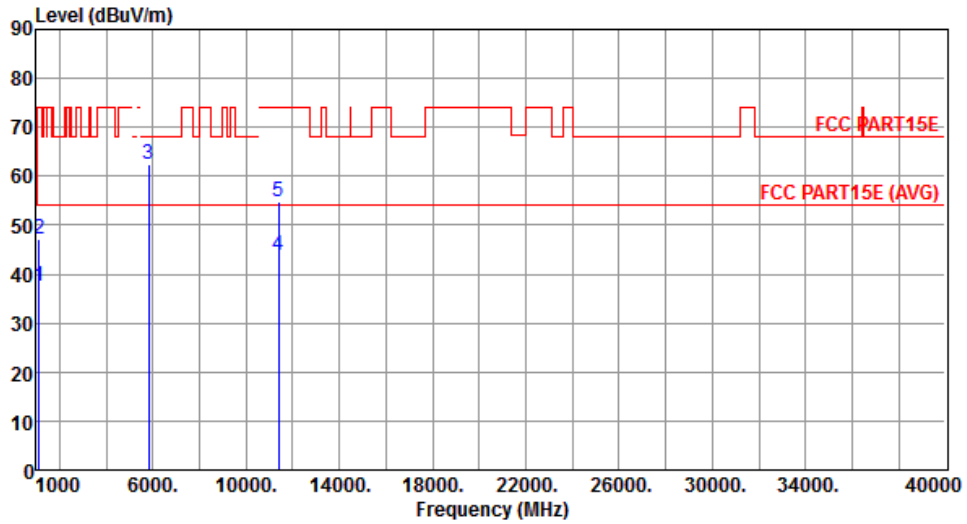

	Freq. MHz	Emission level dBuV/m	Limit dBuV/m	Margin dB	SA reading dBuV	Factor dB	Remark	ANT High cm	Turn Table deg
1	1125.00	37.68	54.00	-16.32	47.19	-9.51	Average	---	---
2	1125.00	47.29	74.00	-26.71	56.80	-9.51	Peak	---	---
3	5825.00	62.28	68.20	-5.92	56.66	5.62	Peak	---	---
4	11380.00	43.79	54.00	-10.21	29.02	14.77	Average	---	---
5	11380.00	54.92	74.00	-19.08	40.15	14.77	Peak	---	---

Note 1: Emission Level (dBuV/m) = SA Reading (dBuV/m) + Factor\* (dB)

\*Factor includes antenna factor , cable loss and amplifier gain

Note 2: Margin (dB) = Emission level (dBuV/m) – Limit (dBuV/m).

<b>Modulation</b>	VHT80	<b>Test Freq. (MHz)</b>	5690
<b>Polarization</b>	Vertical		

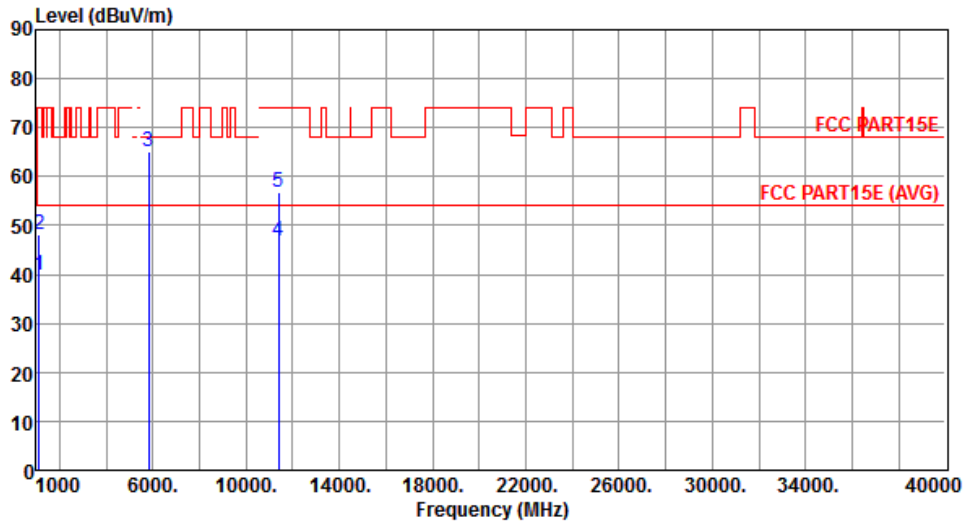

	Freq. MHz	Emission level dBuV/m	Limit dBuV/m	Margin dB	SA reading dBuV	Factor dB	Remark	ANT High cm	Turn Table deg
1	1125.00	39.89	54.00	-14.11	49.40	-9.51	Average	---	---
2	1125.00	48.32	74.00	-25.68	57.83	-9.51	Peak	---	---
3	5825.00	65.08	68.20	-3.12	59.46	5.62	Peak	---	---
4	11380.00	46.66	54.00	-7.34	31.89	14.77	Average	---	---
5	11380.00	56.80	74.00	-17.20	42.03	14.77	Peak	---	---

Note 1: Emission Level (dBuV/m) = SA Reading (dBuV/m) + Factor\* (dB)

\*Factor includes antenna factor , cable loss and amplifier gain

Note 2: Margin (dB) = Emission level (dBuV/m) – Limit (dBuV/m).

## 3.7 Frequency Stability

### 3.7.1 Limit of Frequency Stability

Manufacturers of U-NII devices are responsible for ensuring frequency stability such that an emission is maintained within the band of operation under all conditions of normal operation as specified in the user's manual.

### 3.7.2 Test Procedures

1. The EUT is installed in an environment test chamber with external power source.
2. Set the chamber to operate at 50 centigrade and external power source to output at nominal voltage of EUT.
3. A sufficient stabilization period at each temperature is used prior to each frequency measurement.
4. When temperature is stabled, measure the frequency stability.
5. The test shall be performed under -30 to 50 centigrade and 85 to 115 percent of the nominal voltage. Change setting of chamber and external power source to complete all conditions.

### 3.7.3 Test Setup

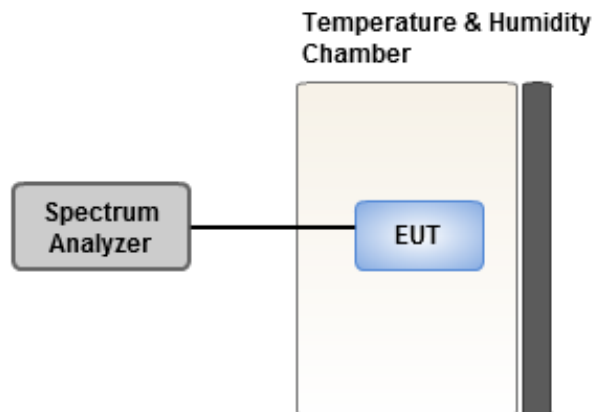

### 3.7.4 Test Result of Frequency Stability

Frequency: 5320 MHz	Frequency Drift (ppm)			
	0 minute	2 minutes	5 minutes	10 minutes
T20°C Vmax	1.38	1.36	1.45	1.36
T20°C Vmin	1.41	1.44	1.41	1.42
T50°C Vnom	1.80	1.76	1.88	1.79
T40°C Vnom	2.11	2.19	2.14	2.10
T30°C Vnom	1.74	1.75	1.74	1.83
T20°C Vnom	1.52	1.58	1.59	1.53
T10°C Vnom	1.47	1.52	1.44	1.50
T0°C Vnom	1.24	1.26	1.29	1.25
T-10°C Vnom	-0.48	-0.42	-0.45	-0.61
T-20°C Vnom	-1.09	-1.01	-1.02	-1.02
T-30°C Vnom	-1.97	-1.88	-1.94	-1.95
Vnom [Vdc]: 110		Vmax [Vdc]: 126.5		Vmin [Vdc]: 93.5
Tnom [°C]: 20		Tmax [°C]: 50		Tmin [°C]: -30

## 4 Test laboratory information

Established in 2012, ICC provides foremost EMC & RF Testing and advisory consultation services by our skilled engineers and technicians. Our services employ a wide variety of advanced edge test equipment and one of the widest certification extents in the business.

International Certification Corp, it is our definitive objective is to institute long term, trust-based associations with our clients. The expectation we set up with our clients is based on outstanding service, practical expertise and devotion to a certified value structure. Our passion is to grant our clients with best EMC / RF services by oriented knowledgeable and accommodating staff.

Our Test sites are located at Linkou District and Kwei Shan Hsiang. Location map can be found on our website <http://www.icertifi.com.tw>.

### **Linkou**

Tel: 886-2-2601-1640

No. 30-2, Ding Fwu Tsuen, Lin Kou District, New Taipei City, Taiwan, R.O.C.

### **Kwei Shan**

Tel: 886-3-271-8666

No. 3-1, Lane 6, Wen San 3rd St., Kwei Shan Hsiang, Tao Yuan Hsien 333, Taiwan, R.O.C.

If you have any suggestion, please feel free to contact us as below information

Tel: 886-3-271-8666

Fax: 886-3-318-0155

Email: ICC\_Service@icertifi.com.tw

==END==