

FCC Test Report

FCC ID : ACQ-STREAMTV
Equipment : Stream TV
Model No. : Stream TV
Brand Name : Verizon
Applicant : ARRIS
Address : 101 Tournament Drive, Horsham
Pennsylvania, United States,19044
Standard : 47 CFR FCC Part 15.247
Received Date : Mar. 11, 2021
Tested Date : Apr. 07 ~ Apr. 20, 2021

We, International Certification Corporation, would like to declare that the tested sample has been evaluated and in compliance with the requirement of the above standards. The test results contained in this report refer exclusively to the product. It may be duplicated completely for legal use with the approval of the applicant. It shall not be reproduced except in full without the written approval of our laboratory.

Reviewed by:

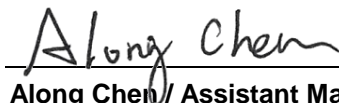

Along Chen / Assistant Manager

Approved by:



Gary Chang / Manager



Table of Contents

| | | |
|----------|---|-----------|
| 1 | GENERAL DESCRIPTION | 5 |
| 1.1 | Information..... | 5 |
| 1.2 | Local Support Equipment List | 7 |
| 1.3 | Test Setup Chart | 7 |
| 1.4 | Test Equipment List and Calibration Data..... | 8 |
| 1.5 | Test Standards | 9 |
| 1.6 | Reference Guidance | 9 |
| 1.7 | Deviation from Test Standard and Measurement Procedure..... | 9 |
| 1.8 | Measurement Uncertainty | 9 |
| 2 | TEST CONFIGURATION | 10 |
| 2.1 | Testing Facility..... | 10 |
| 2.2 | The Worst Test Modes and Channel Details | 10 |
| 3 | TRANSMITTER TEST RESULTS..... | 11 |
| 3.1 | Conducted Emissions..... | 11 |
| 3.2 | 6dB and Occupied Bandwidth | 16 |
| 3.3 | RF Output Power | 20 |
| 3.4 | Power Spectral Density | 22 |
| 3.5 | Emissions in Restricted Frequency Bands..... | 26 |
| 3.6 | Emissions in non-restricted Frequency Bands..... | 38 |
| 4 | TEST LABORATORY INFORMATION | 41 |

Release Record

| Report No. | Version | Description | Issued Date |
|------------|---------|---------------|--------------|
| FR131101AE | Rev. 01 | Initial issue | May 13, 2021 |

Summary of Test Results

| FCC Rules | Test Items | Measured | Result |
|---------------------|-----------------------------------|---|--------|
| 15.207 | AC Power Line Conducted Emissions | [dBuV]: 0.608MHz 44.32 (Margin -1.68dB) - AV | Pass |
| 15.247(d) 15.209 | Radiated Emissions | [dBuV/m at 3m]: 31.21MHz 36.29 (Margin -3.71dB) - PK | Pass |
| 15.247(b)(3) | Maximum Output Power | Power [dBm]: 2.15 | Pass |
| 15.247(a)(2) | 6dB Bandwidth | Meet the requirement of limit | Pass |
| 15.247(e) | Power Spectral Density | Meet the requirement of limit | Pass |
| 15.203 | Antenna Requirement | Meet the requirement of limit | Pass |

Declaration of Conformity:

The test results with all measurement uncertainty excluded are presented in accordance with the regulation limits or requirements declared by manufacturers.

Comments and Explanations:

The declared of product specification for EUT presented in the report are provided by the manufacturer, and the manufacturer takes all the responsibilities for the accuracy of product specification.

1 General Description

1.1 Information

1.1.1 Specification of the Equipment under Test (EUT)

| RF General Information | | | | |
|---|----------------|-----------------|----------------|-----------|
| Frequency Range (MHz) | Bluetooth Mode | Ch. Freq. (MHz) | Channel Number | Data Rate |
| 2400-2483.5 | V5.0 LE | 2402-2480 | 0-39 [40] | 1 Mbps |
| Note 1: Bluetooth LE (Low energy) uses GFSK modulation. | | | | |

1.1.2 Antenna Details

| Ant. No. | Type | Connector | Gain (dBi) | Remarks |
|----------|------|-----------|------------|---------|
| 1 | Chip | N/A | 2.7 | --- |

1.1.3 USB chip

Two sources for USB chip

| | |
|----------|---|
| Source 1 | IC PER 3.3V SMD QFN24 GP USB HUB Brand: GENESYS Model: GL852G |
| Source 2 | IC PER 3.3V SMD QFN24 GP USB HUB Brand: GENESYS Model: GL850G |

1.1.4 Power Supply Type of Equipment under Test (EUT)

| | |
|-------------------|-------------------|
| Power Supply Type | 5Vdc from adapter |
|-------------------|-------------------|

1.1.5 Accessories

| Accessories | | |
|-------------|----------------|--|
| No. | Equipment | Description |
| 1 | AC adapter | Brand: KUANTECH Model: KSC-10C-050200HU I/P: 100-120Vac, 47-63Hz, 0.3A O/P: 5Vdc, 2A Power Line: 1m non-shielded without core (USB-C cable) |
| 2 | HDMI | 0.95m non-shielded without core |
| 3 | Remote control | Model: RC4513101/01BRP Brand: Verizon |

1.1.6 Channel List

| Frequency band (MHz) | | | | 2400~2483.5 | | | |
|----------------------|-----------------|---------|-----------------|-------------|-----------------|---------|-----------------|
| Channel | Frequency (MHz) | Channel | Frequency (MHz) | Channel | Frequency (MHz) | Channel | Frequency (MHz) |
| 37 | 2402 | 9 | 2422 | 18 | 2442 | 28 | 2462 |
| 0 | 2404 | 10 | 2424 | 19 | 2444 | 29 | 2464 |
| 1 | 2406 | 38 | 2426 | 20 | 2446 | 30 | 2466 |
| 2 | 2408 | 11 | 2428 | 21 | 2448 | 31 | 2468 |
| 3 | 2410 | 12 | 2430 | 22 | 2450 | 32 | 2470 |
| 4 | 2412 | 13 | 2432 | 23 | 2452 | 33 | 2472 |
| 5 | 2414 | 14 | 2434 | 24 | 2454 | 34 | 2474 |
| 6 | 2416 | 15 | 2436 | 25 | 2456 | 35 | 2476 |
| 7 | 2418 | 16 | 2438 | 26 | 2458 | 36 | 2478 |
| 8 | 2420 | 17 | 2440 | 27 | 2460 | 39 | 2480 |

1.1.7 Test Tool and Duty Cycle

| | | |
|-----------------------------------|-----------------------|-------------------------|
| Test Tool | Tera Term V4.66 | |
| Duty Cycle and Duty Factor | Duty Cycle (%) | Duty Factor (dB) |
| | 64.81% | 1.88 |

1.1.8 Power Index of Test Tool

| Modulation Mode | Test Frequency (MHz) | | |
|-----------------|----------------------|---------|---------|
| | 2402 | 2440 | 2480 |
| BT LE-1Mbps | Default | Default | Default |

1.2 Local Support Equipment List

| Support Equipment List | | | | | |
|------------------------|---------------|-----------|----------------|--------|---------|
| No. | Equipment | Brand | Model | FCC ID | Remarks |
| 1 | LCD Monitor | ASUS | MX27UCS | --- | --- |
| 2 | USB 3.0 flash | Transcend | JetFlash 700 | --- | --- |
| 3 | Notebook | DELL | Latitude E5470 | DoC | --- |

Note: The support notebook is connected to EUT via fixture and is disconnected from EUT and removed from test table after sending RF command to control EUT to transmit continuously.

1.3 Test Setup Chart

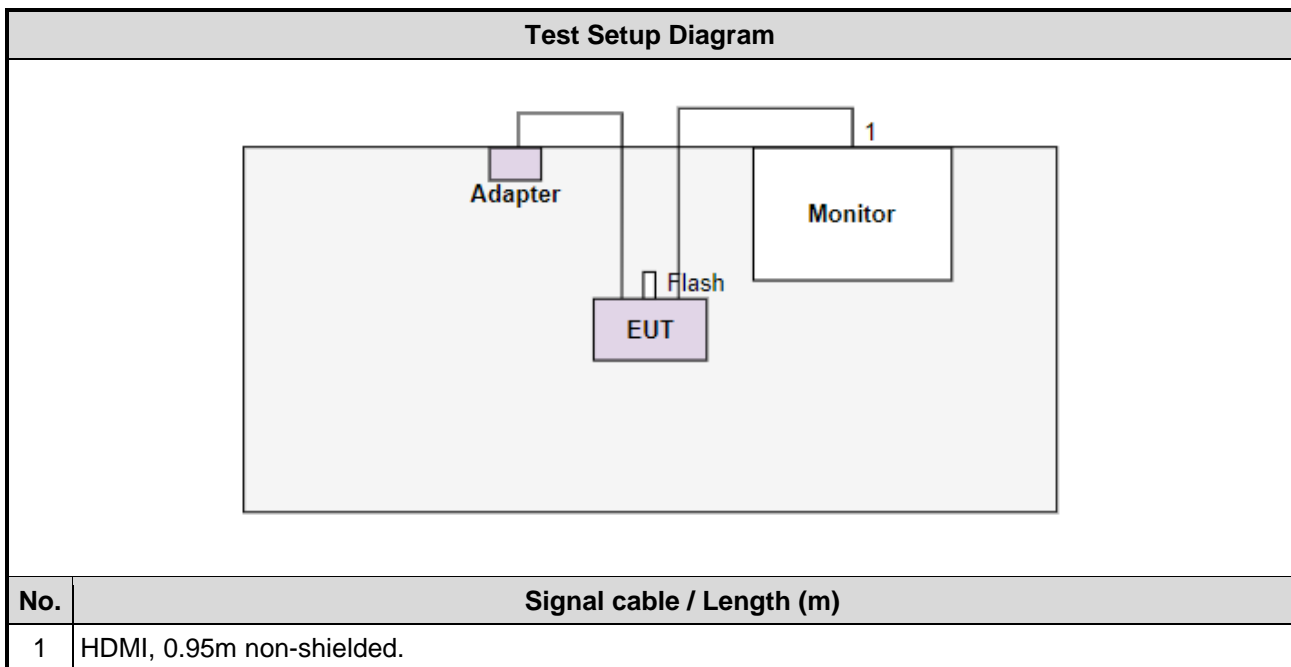

1.4 Test Equipment List and Calibration Data

| | | | | | |
|---|-------------------------------|------------------|-------------------|-------------------------|--------------------------|
| Test Item | Conducted Emission | | | | |
| Test Site | Conduction room 1 / (CO01-WS) | | | | |
| Tested Date | Apr. 16 ~ Apr. 20, 2021 | | | | |
| Instrument | Brand | Model No. | Serial No. | Calibration Date | Calibration Until |
| Receiver | R&S | ESR3 | 101658 | Feb. 08, 2021 | Feb. 07, 2022 |
| LISN | R&S | ENV216 | 101579 | Mar. 17, 2021 | Mar. 16, 2022 |
| RF Cable-CON | Woken | CFD200-NL | CFD200-NL-001 | Oct. 21, 2020 | Oct. 20, 2021 |
| Measurement Software | AUDIX | e3 | 6.120210k | NA | NA |
| Note: Calibration Interval of instruments listed above is one year. | | | | | |

| | | | | | |
|---|----------------------------|---------------------------|-------------------|-------------------------|--------------------------|
| Test Item | Radiated Emission | | | | |
| Test Site | 966 chamber1 / (03CH01-WS) | | | | |
| Tested Date | Apr. 07 ~ Apr. 14, 2021 | | | | |
| Instrument | Brand | Model No. | Serial No. | Calibration Date | Calibration Until |
| Receiver | R&S | ESR3 | 101658 | Feb. 08, 2021 | Feb. 07, 2022 |
| Spectrum Analyzer | R&S | FSV40 | 101498 | Dec. 04, 2020 | Dec. 03, 2021 |
| Loop Antenna | R&S | HFH2-Z2 | 100330 | Nov. 17, 2020 | Nov. 16, 2021 |
| Bilog Antenna | SCHWARZBECK | VULB9168 | VULB9168-522 | Jul. 10, 2020 | Jul. 09, 2021 |
| Horn Antenna 1G-18G | SCHWARZBECK | BBHA 9120 D | BBHA 9120 D 1096 | Dec. 11, 2020 | Dec. 10, 2021 |
| Horn Antenna 18G-40G | SCHWARZBECK | BBHA 9170 | BBHA 9170517 | Nov. 06, 2020 | Nov. 05, 2021 |
| Preamplifier | EMC | EMC02325 | 980225 | Jul. 03, 2020 | Jul. 02, 2021 |
| Preamplifier | Agilent | 83017A | MY39501308 | Sep. 26, 2020 | Sep. 25, 2021 |
| Preamplifier | EMC | EMC184045B | 980192 | Jul. 21, 2020 | Jul. 20, 2021 |
| Loop Antenna Cable | KOAX KABEL | 101354-BW | 101354-BW | Oct. 06, 2020 | Oct. 05, 2021 |
| LF cable 3M | Woken | CFD400NL-LW | CFD400NL-001 | Oct. 06, 2020 | Oct. 05, 2021 |
| LF cable 11M | EMC | EMCCFD400-NW-N W-11000 | 200801 | Oct. 06, 2020 | Oct. 05, 2021 |
| LF cable 1M | EMC | EMCCFD400-NM-N M-1000 | 160502 | Oct. 06, 2020 | Oct. 05, 2021 |
| RF Cable | HUBER+SUHNER | SUCOFLEX104 | MY16019/4 | Oct. 06, 2020 | Oct. 05, 2021 |
| RF Cable | HUBER+SUHNER | SUCOFLEX104 | MY16014/4 | Oct. 06, 2020 | Oct. 05, 2021 |
| Measurement Software | AUDIX | e3 | 6.120210g | NA | NA |
| Note: Calibration Interval of instruments listed above is one year. | | | | | |

| | | | | | |
|---|---------------|------------------|-------------------|-------------------------|--------------------------|
| Test Item | RF Conducted | | | | |
| Test Site | (TH01-WS) | | | | |
| Tested Date | Apr. 13, 2021 | | | | |
| Instrument | Brand | Model No. | Serial No. | Calibration Date | Calibration Until |
| Spectrum Analyzer | R&S | FSV40 | 101063 | Apr. 30, 2020 | Apr. 29, 2021 |
| Power Meter | Anritsu | ML2495A | 1241002 | Nov. 04, 2020 | Nov. 03, 2021 |
| Power Sensor | Anritsu | MA2411B | 1207366 | Nov. 04, 2020 | Nov. 03, 2021 |
| Measurement Software | - | SENSE-15247_FS | V5.10.7.11 | NA | NA |
| Note: Calibration Interval of instruments listed above is one year. | | | | | |

1.5 Test Standards

47 CFR FCC Part 15.247

ANSI C63.10-2013

1.6 Reference Guidance

FCC KDB 558074 D01 15.247 Meas Guidance v05r02

1.7 Deviation from Test Standard and Measurement Procedure

None

1.8 Measurement Uncertainty

The measurement uncertainties given below are based on a 95% confidence level (based on a coverage factor ($k=2$)).

| Measurement Uncertainty | |
|--------------------------------|-----------------|
| Parameters | Uncertainty |
| Bandwidth | ± 34.130 Hz |
| Conducted power | ± 0.808 dB |
| Power density | ± 0.583 dB |
| Conducted emission | ± 2.715 dB |
| AC conducted emission | ± 2.92 dB |
| Radiated emission ≤ 1 GHz | ± 3.41 dB |
| Radiated emission > 1 GHz | ± 4.59 dB |

2 Test Configuration

2.1 Testing Facility

| | |
|-----------------------------|--|
| Test Laboratory | International Certification Corporation |
| Test Site | CO01-WS, 03CH01-WS, TH01-WS |
| Address of Test Site | No.3-1, Lane 6, Wen San 3rd St., Kwei Shan Dist., Tao Yuan City 33381, Taiwan (R.O.C.) |

- FCC Designation No.: TW2732
- FCC site registration No.: 181692
- ISED#: 10807A
- CAB identifier: TW2732

2.2 The Worst Test Modes and Channel Details

| Test item | Mode | Test Frequency (MHz) | Data Rate | Test Configuration |
|--|-------|----------------------|-----------|--------------------|
| AC Power Line Conducted Emissions Radiated Emissions ≤ 1GHz | BT LE | 2480 | 1Mbps | 1, 2 |
| Maximum Output Power 6dB bandwidth Power spectral density Radiated Emissions > 1GHz | BT LE | 2402, 2440, 2480 | 1Mbps | 1 |
| NOTE: | | | | |
| 1. The EUT was pretested with 3 orientations placed on the table for the radiated emission measurement – X, Y, and Z-plane. The X-plane results were found as the worst case and were shown in this report. | | | | |
| 2. There are two USB chips provided for the test: Test Configuration 1: USB chip 1, model GL852G Test Configuration 2: USB chip 2, model GL850G | | | | |

3 Transmitter Test Results

3.1 Conducted Emissions

3.1.1 Limit of Conducted Emissions

| Conducted Emissions Limit | | |
|---------------------------|------------|-----------|
| Frequency Emission (MHz) | Quasi-Peak | Average |
| 0.15-0.5 | 66 - 56 * | 56 - 46 * |
| 0.5-5 | 56 | 46 |
| 5-30 | 60 | 50 |

Note 1: * Decreases with the logarithm of the frequency.

3.1.2 Test Procedures

1. The device is placed on a test table, raised 80 cm above the reference ground plane. The vertical conducting plane is located 40 cm to the rear of the device.
2. The device is connected to line impedance stabilization network (LISN) and other accessories are connected to other LISN. Measured levels of AC power line conducted emission are across the 50 Ω LISN port.
3. AC conducted emission measurements is made over frequency range from 150 kHz to 30 MHz.
4. This measurement was performed with AC 120V/60Hz

3.1.3 Test Setup



Note: 1. Support units were connected to second LISN.

2. Both of LISNs (AMN) are 80 cm from EUT and at least 80 cm from other units and other metal planes

3.1.4 Test Result of Conducted Emissions

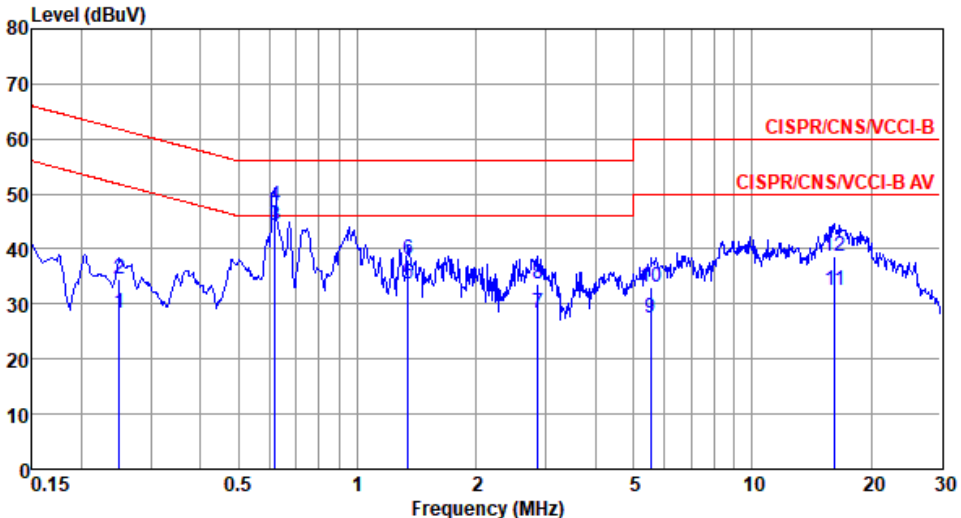
| Modulation Mode | BT-LE(1Mbps) | Test Freq. (MHz) | 2480 | | | | | | | | | | | | | | | | | | | | | | | | | | | | | | | | | | | | | | | | | | | | | | | | | | | | | | | | | | | | | | | | | | | | | | | | | | | | | | | | | | | | | | | | | | | | | | | | | | | | | | | | | | | | | | | | | | | | | |
|---|--------------|--------------------|-----------------------|---------------------|-----------------------|---------------|-----------------------|---------------------|-----------------------|--------------|---------------------|--------|---|-------|-------|-------|--------|-------|------|------|---------|---|-------|-------|-------|--------|-------|------|------|----|----|-------|-------|-------|-------|-------|------|------|---------|---|-------|-------|-------|-------|-------|------|------|----|---|-------|-------|-------|--------|-------|------|------|---------|---|-------|-------|-------|--------|-------|------|------|----|---|-------|-------|-------|--------|-------|-------|------|---------|---|-------|-------|-------|--------|-------|-------|------|----|---|-------|-------|-------|--------|-------|-------|------|---------|----|-------|-------|-------|--------|-------|-------|------|----|----|--------|-------|-------|--------|-------|-------|------|---------|----|--------|-------|-------|--------|-------|-------|------|----|
| Power Phase | Line | Test Configuration | 1 | | | | | | | | | | | | | | | | | | | | | | | | | | | | | | | | | | | | | | | | | | | | | | | | | | | | | | | | | | | | | | | | | | | | | | | | | | | | | | | | | | | | | | | | | | | | | | | | | | | | | | | | | | | | | | | | | | | | | |
| <p>Test by : Alex Tsai Temperature: 22°C Humidity: 60%</p> | | | | | | | | | | | | | | | | | | | | | | | | | | | | | | | | | | | | | | | | | | | | | | | | | | | | | | | | | | | | | | | | | | | | | | | | | | | | | | | | | | | | | | | | | | | | | | | | | | | | | | | | | | | | | | | | | | | | | | | | |
|  <p>The graph shows the Level (dBuV) on the y-axis (0 to 80) versus Frequency (MHz) on the x-axis (0.15 to 30). Two red limit lines are shown: CISPR/CNS/VCCI-B (upper) and CISPR/CNS/VCCI-B AV (lower). A blue waveform represents the measured emissions, with several peaks marked by vertical lines and numbered 1 through 12.</p> | | | | | | | | | | | | | | | | | | | | | | | | | | | | | | | | | | | | | | | | | | | | | | | | | | | | | | | | | | | | | | | | | | | | | | | | | | | | | | | | | | | | | | | | | | | | | | | | | | | | | | | | | | | | | | | | | | | | | | | | |
| <table border="1"> <thead> <tr> <th></th> <th>Freq MHz</th> <th>Level dBuV</th> <th>Limit Line dBuV</th> <th>Over Limit dB</th> <th>Read Level dBuV</th> <th>Factor dB</th> <th>Cable loss dB</th> <th>Remark</th> </tr> </thead> <tbody> <tr><td>1</td><td>0.249</td><td>28.48</td><td>51.78</td><td>-23.30</td><td>18.55</td><td>9.86</td><td>0.07</td><td>Average</td></tr> <tr><td>2</td><td>0.249</td><td>34.51</td><td>61.78</td><td>-27.27</td><td>24.58</td><td>9.86</td><td>0.07</td><td>QP</td></tr> <tr><td>3*</td><td>0.617</td><td>44.14</td><td>46.00</td><td>-1.86</td><td>34.10</td><td>9.94</td><td>0.10</td><td>Average</td></tr> <tr><td>4</td><td>0.617</td><td>47.75</td><td>56.00</td><td>-8.25</td><td>37.71</td><td>9.94</td><td>0.10</td><td>QP</td></tr> <tr><td>5</td><td>1.345</td><td>33.68</td><td>46.00</td><td>-12.32</td><td>23.54</td><td>9.99</td><td>0.15</td><td>Average</td></tr> <tr><td>6</td><td>1.345</td><td>38.12</td><td>56.00</td><td>-17.88</td><td>27.98</td><td>9.99</td><td>0.15</td><td>QP</td></tr> <tr><td>7</td><td>2.869</td><td>28.27</td><td>46.00</td><td>-17.73</td><td>18.01</td><td>10.02</td><td>0.24</td><td>Average</td></tr> <tr><td>8</td><td>2.869</td><td>33.75</td><td>56.00</td><td>-22.25</td><td>23.49</td><td>10.02</td><td>0.24</td><td>QP</td></tr> <tr><td>9</td><td>5.535</td><td>27.60</td><td>50.00</td><td>-22.40</td><td>17.21</td><td>10.06</td><td>0.33</td><td>Average</td></tr> <tr><td>10</td><td>5.535</td><td>33.14</td><td>60.00</td><td>-26.86</td><td>22.75</td><td>10.06</td><td>0.33</td><td>QP</td></tr> <tr><td>11</td><td>16.226</td><td>32.33</td><td>50.00</td><td>-17.67</td><td>21.49</td><td>10.22</td><td>0.62</td><td>Average</td></tr> <tr><td>12</td><td>16.226</td><td>38.57</td><td>60.00</td><td>-21.43</td><td>27.73</td><td>10.22</td><td>0.62</td><td>QP</td></tr> </tbody> </table> | | | | | Freq MHz | Level dBuV | Limit Line dBuV | Over Limit dB | Read Level dBuV | Factor dB | Cable loss dB | Remark | 1 | 0.249 | 28.48 | 51.78 | -23.30 | 18.55 | 9.86 | 0.07 | Average | 2 | 0.249 | 34.51 | 61.78 | -27.27 | 24.58 | 9.86 | 0.07 | QP | 3* | 0.617 | 44.14 | 46.00 | -1.86 | 34.10 | 9.94 | 0.10 | Average | 4 | 0.617 | 47.75 | 56.00 | -8.25 | 37.71 | 9.94 | 0.10 | QP | 5 | 1.345 | 33.68 | 46.00 | -12.32 | 23.54 | 9.99 | 0.15 | Average | 6 | 1.345 | 38.12 | 56.00 | -17.88 | 27.98 | 9.99 | 0.15 | QP | 7 | 2.869 | 28.27 | 46.00 | -17.73 | 18.01 | 10.02 | 0.24 | Average | 8 | 2.869 | 33.75 | 56.00 | -22.25 | 23.49 | 10.02 | 0.24 | QP | 9 | 5.535 | 27.60 | 50.00 | -22.40 | 17.21 | 10.06 | 0.33 | Average | 10 | 5.535 | 33.14 | 60.00 | -26.86 | 22.75 | 10.06 | 0.33 | QP | 11 | 16.226 | 32.33 | 50.00 | -17.67 | 21.49 | 10.22 | 0.62 | Average | 12 | 16.226 | 38.57 | 60.00 | -21.43 | 27.73 | 10.22 | 0.62 | QP |
| | Freq MHz | Level dBuV | Limit Line dBuV | Over Limit dB | Read Level dBuV | Factor dB | Cable loss dB | Remark | | | | | | | | | | | | | | | | | | | | | | | | | | | | | | | | | | | | | | | | | | | | | | | | | | | | | | | | | | | | | | | | | | | | | | | | | | | | | | | | | | | | | | | | | | | | | | | | | | | | | | | | | | | | | | | | |
| 1 | 0.249 | 28.48 | 51.78 | -23.30 | 18.55 | 9.86 | 0.07 | Average | | | | | | | | | | | | | | | | | | | | | | | | | | | | | | | | | | | | | | | | | | | | | | | | | | | | | | | | | | | | | | | | | | | | | | | | | | | | | | | | | | | | | | | | | | | | | | | | | | | | | | | | | | | | | | | | |
| 2 | 0.249 | 34.51 | 61.78 | -27.27 | 24.58 | 9.86 | 0.07 | QP | | | | | | | | | | | | | | | | | | | | | | | | | | | | | | | | | | | | | | | | | | | | | | | | | | | | | | | | | | | | | | | | | | | | | | | | | | | | | | | | | | | | | | | | | | | | | | | | | | | | | | | | | | | | | | | | |
| 3* | 0.617 | 44.14 | 46.00 | -1.86 | 34.10 | 9.94 | 0.10 | Average | | | | | | | | | | | | | | | | | | | | | | | | | | | | | | | | | | | | | | | | | | | | | | | | | | | | | | | | | | | | | | | | | | | | | | | | | | | | | | | | | | | | | | | | | | | | | | | | | | | | | | | | | | | | | | | | |
| 4 | 0.617 | 47.75 | 56.00 | -8.25 | 37.71 | 9.94 | 0.10 | QP | | | | | | | | | | | | | | | | | | | | | | | | | | | | | | | | | | | | | | | | | | | | | | | | | | | | | | | | | | | | | | | | | | | | | | | | | | | | | | | | | | | | | | | | | | | | | | | | | | | | | | | | | | | | | | | | |
| 5 | 1.345 | 33.68 | 46.00 | -12.32 | 23.54 | 9.99 | 0.15 | Average | | | | | | | | | | | | | | | | | | | | | | | | | | | | | | | | | | | | | | | | | | | | | | | | | | | | | | | | | | | | | | | | | | | | | | | | | | | | | | | | | | | | | | | | | | | | | | | | | | | | | | | | | | | | | | | | |
| 6 | 1.345 | 38.12 | 56.00 | -17.88 | 27.98 | 9.99 | 0.15 | QP | | | | | | | | | | | | | | | | | | | | | | | | | | | | | | | | | | | | | | | | | | | | | | | | | | | | | | | | | | | | | | | | | | | | | | | | | | | | | | | | | | | | | | | | | | | | | | | | | | | | | | | | | | | | | | | | |
| 7 | 2.869 | 28.27 | 46.00 | -17.73 | 18.01 | 10.02 | 0.24 | Average | | | | | | | | | | | | | | | | | | | | | | | | | | | | | | | | | | | | | | | | | | | | | | | | | | | | | | | | | | | | | | | | | | | | | | | | | | | | | | | | | | | | | | | | | | | | | | | | | | | | | | | | | | | | | | | | |
| 8 | 2.869 | 33.75 | 56.00 | -22.25 | 23.49 | 10.02 | 0.24 | QP | | | | | | | | | | | | | | | | | | | | | | | | | | | | | | | | | | | | | | | | | | | | | | | | | | | | | | | | | | | | | | | | | | | | | | | | | | | | | | | | | | | | | | | | | | | | | | | | | | | | | | | | | | | | | | | | |
| 9 | 5.535 | 27.60 | 50.00 | -22.40 | 17.21 | 10.06 | 0.33 | Average | | | | | | | | | | | | | | | | | | | | | | | | | | | | | | | | | | | | | | | | | | | | | | | | | | | | | | | | | | | | | | | | | | | | | | | | | | | | | | | | | | | | | | | | | | | | | | | | | | | | | | | | | | | | | | | | |
| 10 | 5.535 | 33.14 | 60.00 | -26.86 | 22.75 | 10.06 | 0.33 | QP | | | | | | | | | | | | | | | | | | | | | | | | | | | | | | | | | | | | | | | | | | | | | | | | | | | | | | | | | | | | | | | | | | | | | | | | | | | | | | | | | | | | | | | | | | | | | | | | | | | | | | | | | | | | | | | | |
| 11 | 16.226 | 32.33 | 50.00 | -17.67 | 21.49 | 10.22 | 0.62 | Average | | | | | | | | | | | | | | | | | | | | | | | | | | | | | | | | | | | | | | | | | | | | | | | | | | | | | | | | | | | | | | | | | | | | | | | | | | | | | | | | | | | | | | | | | | | | | | | | | | | | | | | | | | | | | | | | |
| 12 | 16.226 | 38.57 | 60.00 | -21.43 | 27.73 | 10.22 | 0.62 | QP | | | | | | | | | | | | | | | | | | | | | | | | | | | | | | | | | | | | | | | | | | | | | | | | | | | | | | | | | | | | | | | | | | | | | | | | | | | | | | | | | | | | | | | | | | | | | | | | | | | | | | | | | | | | | | | | |
| <p>Note 1: Level (dBuV) = Read Level (dBuV) + LISN Factor (dB) + Cable Loss (dB). Note 2: Over Limit (dB) = Level (dBuV) – Limit Line (dBuV).</p> | | | | | | | | | | | | | | | | | | | | | | | | | | | | | | | | | | | | | | | | | | | | | | | | | | | | | | | | | | | | | | | | | | | | | | | | | | | | | | | | | | | | | | | | | | | | | | | | | | | | | | | | | | | | | | | | | | | | | | | | |

| | | | |
|------------------------|--------------|---------------------------|------|
| Modulation Mode | BT-LE(1Mbps) | Test Freq. (MHz) | 2480 |
| Power Phase | Neutral | Test Configuration | 1 |

Test by : Alex Tsai Temperature: 22°C Humidity: 60%

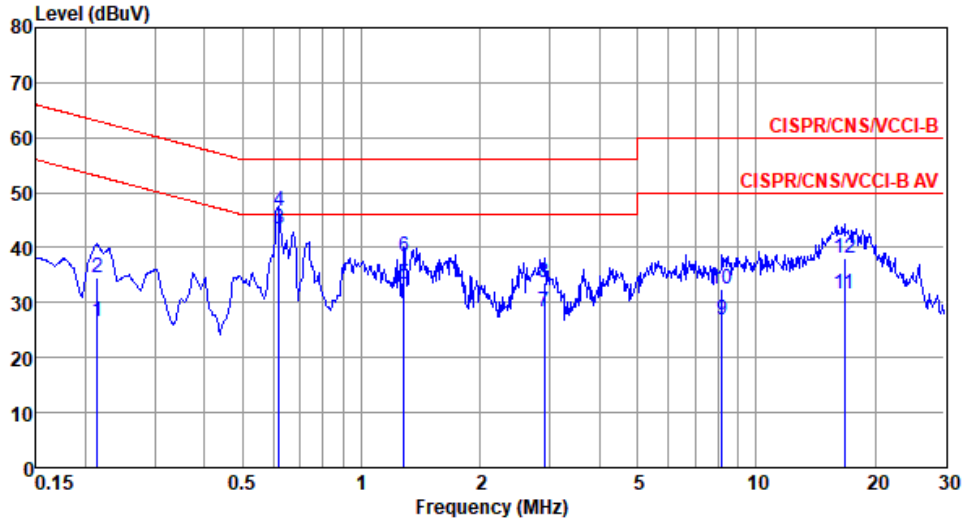

| | Freq MHz | Level dBuV | Limit Line dBuV | Over Limit dB | Read Level dBuV | Factor dB | Cable loss dB | Remark |
|----|-------------|---------------|-----------------------|---------------------|-----------------------|--------------|---------------------|---------|
| 1 | 0.214 | 26.42 | 53.05 | -26.63 | 16.53 | 9.83 | 0.06 | Average |
| 2 | 0.214 | 34.67 | 63.05 | -28.38 | 24.78 | 9.83 | 0.06 | QP |
| 3* | 0.617 | 43.52 | 46.00 | -2.48 | 33.56 | 9.86 | 0.10 | Average |
| 4 | 0.617 | 46.78 | 56.00 | -9.22 | 36.82 | 9.86 | 0.10 | QP |
| 5 | 1.282 | 33.35 | 46.00 | -12.65 | 23.30 | 9.91 | 0.14 | Average |
| 6 | 1.282 | 38.50 | 56.00 | -17.50 | 28.45 | 9.91 | 0.14 | QP |
| 7 | 2.900 | 28.33 | 46.00 | -17.67 | 18.13 | 9.96 | 0.24 | Average |
| 8 | 2.900 | 33.71 | 56.00 | -22.29 | 23.51 | 9.96 | 0.24 | QP |
| 9 | 8.192 | 26.88 | 50.00 | -23.12 | 16.44 | 10.06 | 0.38 | Average |
| 10 | 8.192 | 32.51 | 60.00 | -27.49 | 22.07 | 10.06 | 0.38 | QP |
| 11 | 16.750 | 31.58 | 50.00 | -18.42 | 20.69 | 10.26 | 0.63 | Average |
| 12 | 16.750 | 38.12 | 60.00 | -21.88 | 27.23 | 10.26 | 0.63 | QP |

Note 1: Level (dBuV) = Read Level (dBuV) + LISN Factor (dB) + Cable Loss (dB).
 Note 2: Over Limit (dB) = Level (dBuV) – Limit Line (dBuV).

| | | | |
|------------------------|--------------|---------------------------|------|
| Modulation Mode | BT-LE(1Mbps) | Test Freq. (MHz) | 2480 |
| Power Phase | Line | Test Configuration | 2 |

Test by : Alex Tsai Temperature: 20°C Humidity: 66%

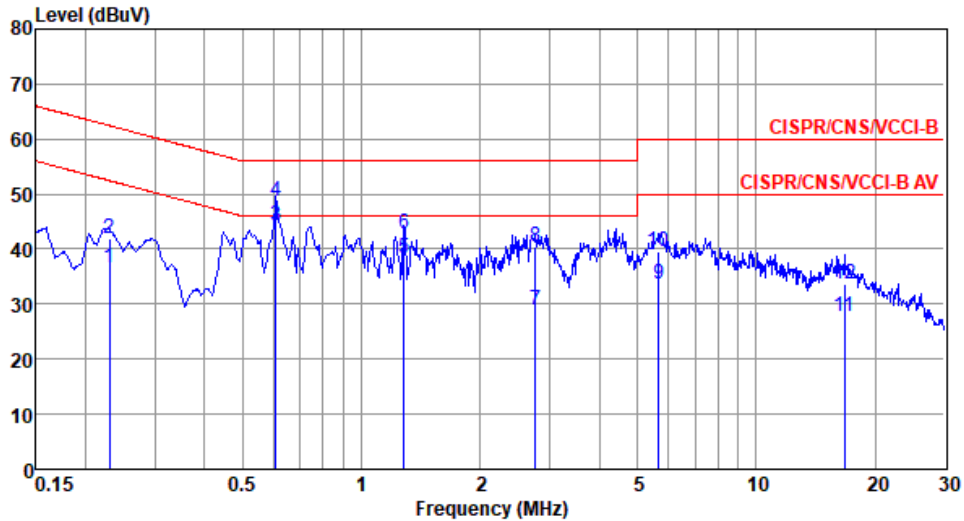

| | Freq MHz | Level dBuV | Limit Line dBuV | Over Limit dB | Read Level dBuV | Factor dB | Cable loss dB | Remark |
|----|-------------|---------------|-----------------------|---------------------|-----------------------|--------------|---------------------|---------|
| 1 | 0.230 | 36.65 | 52.44 | -15.79 | 26.74 | 9.85 | 0.06 | Average |
| 2 | 0.230 | 42.03 | 62.44 | -20.41 | 32.12 | 9.85 | 0.06 | QP |
| 3* | 0.608 | 44.32 | 46.00 | -1.68 | 34.28 | 9.94 | 0.10 | Average |
| 4 | 0.608 | 48.67 | 56.00 | -7.33 | 38.63 | 9.94 | 0.10 | QP |
| 5 | 1.282 | 38.40 | 46.00 | -7.60 | 28.27 | 9.99 | 0.14 | Average |
| 6 | 1.282 | 42.75 | 56.00 | -13.25 | 32.62 | 9.99 | 0.14 | QP |
| 7 | 2.765 | 28.86 | 46.00 | -17.14 | 18.61 | 10.02 | 0.23 | Average |
| 8 | 2.765 | 40.33 | 56.00 | -15.67 | 30.08 | 10.02 | 0.23 | QP |
| 9 | 5.653 | 33.76 | 50.00 | -16.24 | 23.36 | 10.07 | 0.33 | Average |
| 10 | 5.653 | 39.69 | 60.00 | -20.31 | 29.29 | 10.07 | 0.33 | QP |
| 11 | 16.750 | 27.80 | 50.00 | -22.20 | 16.95 | 10.22 | 0.63 | Average |
| 12 | 16.750 | 33.74 | 60.00 | -26.26 | 22.89 | 10.22 | 0.63 | QP |

Note 1: Level (dBuV) = Read Level (dBuV) + LISN Factor (dB) + Cable Loss (dB).
 Note 2: Over Limit (dB) = Level (dBuV) – Limit Line (dBuV).

| | | | |
|------------------------|--------------|---------------------------|------|
| Modulation Mode | BT-LE(1Mbps) | Test Freq. (MHz) | 2480 |
| Power Phase | Neutral | Test Configuration | 2 |

Test by : Alex Tsai Temperature: 20°C Humidity: 66%

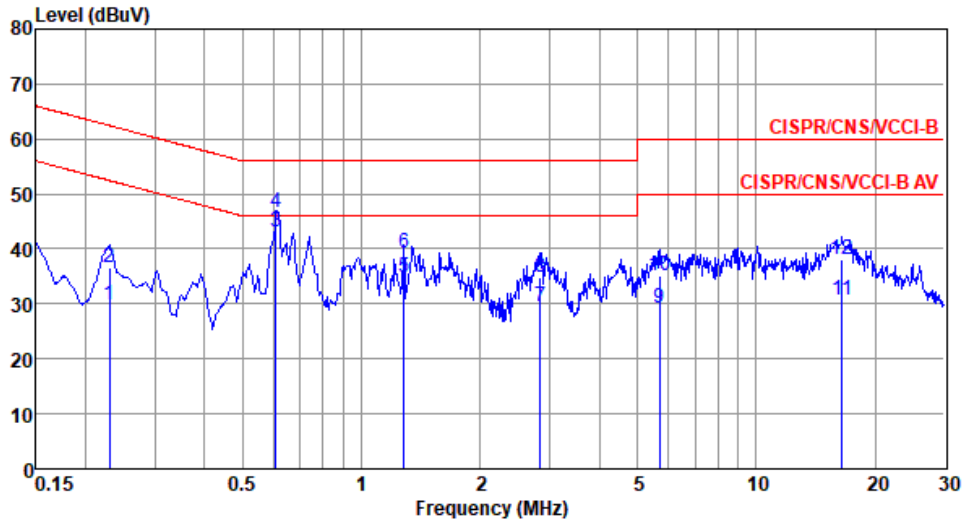

| | Freq MHz | Level dBuV | Limit Line dBuV | Over Limit dB | Read Level dBuV | Factor dB | Cable loss dB | Remark |
|----|-------------|---------------|-----------------------|---------------------|-----------------------|--------------|---------------------|---------|
| 1 | 0.230 | 29.79 | 52.44 | -22.65 | 19.90 | 9.83 | 0.06 | Average |
| 2 | 0.230 | 36.58 | 62.44 | -25.86 | 26.69 | 9.83 | 0.06 | QP |
| 3* | 0.608 | 43.16 | 46.00 | -2.84 | 33.20 | 9.86 | 0.10 | Average |
| 4 | 0.608 | 46.70 | 56.00 | -9.30 | 36.74 | 9.86 | 0.10 | QP |
| 5 | 1.282 | 34.90 | 46.00 | -11.10 | 24.85 | 9.91 | 0.14 | Average |
| 6 | 1.282 | 39.36 | 56.00 | -16.64 | 29.31 | 9.91 | 0.14 | QP |
| 7 | 2.839 | 29.51 | 46.00 | -16.49 | 19.31 | 9.96 | 0.24 | Average |
| 8 | 2.839 | 34.90 | 56.00 | -21.10 | 24.70 | 9.96 | 0.24 | QP |
| 9 | 5.683 | 29.17 | 50.00 | -20.83 | 18.83 | 10.01 | 0.33 | Average |
| 10 | 5.683 | 35.23 | 60.00 | -24.77 | 24.89 | 10.01 | 0.33 | QP |
| 11 | 16.486 | 30.77 | 50.00 | -19.23 | 19.89 | 10.26 | 0.62 | Average |
| 12 | 16.486 | 38.15 | 60.00 | -21.85 | 27.27 | 10.26 | 0.62 | QP |

Note 1: Level (dBuV) = Read Level (dBuV) + LISN Factor (dB) + Cable Loss (dB).
 Note 2: Over Limit (dB) = Level (dBuV) – Limit Line (dBuV).

3.2 6dB and Occupied Bandwidth

3.2.1 Limit of 6dB Bandwidth

The minimum 6dB bandwidth shall be at least 500 kHz.

3.2.2 Test Procedures

6dB Bandwidth

1. Set resolution bandwidth (RBW) = 100 kHz, Video bandwidth = 300 kHz.
2. Detector = Peak, Trace mode = max hold.
3. Sweep = auto couple, Allow the trace to stabilize.
4. Measure the maximum width of the emission that is constrained by the frequencies associated with the two outermost amplitude points (upper and lower) that are attenuated by 6dB relative to the maximum level measured in the fundamental emission.

Occupied Bandwidth

1. Set resolution bandwidth (RBW) = 1% ~ 5 % of OBW, Video bandwidth = 3 x RBW
2. Detector = Sample, Trace mode = max hold.
3. Sweep = auto couple, Allow the trace to stabilize.
4. Use the OBW measurement function of spectrum analyzer to measure the occupied bandwidth.

3.2.3 Test Setup

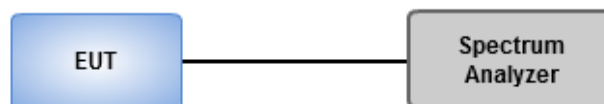

3.2.4 Test Result of 6dB and Occupied Bandwidth

| | | | |
|--------------------------|------------|------------------|---------|
| Ambient Condition | 24°C / 63% | Tested By | Brad Wu |
|--------------------------|------------|------------------|---------|

Summary

| Mode | Max-N dB (Hz) | Max-OBW (Hz) | ITU-Code | Min-N dB (Hz) | Min-OBW (Hz) |
|---------------|------------------|-----------------|----------|------------------|-----------------|
| 2.4-2.4835GHz | - | - | - | - | - |
| BT-LE(1Mbps) | 695.652k | 1.046M | 1M05F1D | 688.406k | 1.042M |

Max-N dB = Maximum 6dB down bandwidth; Max-OBW = Maximum 99% occupied bandwidth;
Min-N dB = Minimum 6dB down bandwidth; Min-OBW = Minimum 99% occupied bandwidth

Result

| Mode | Result | Limit (Hz) | Port 1-N dB (Hz) | Port 1-OBW (Hz) |
|--------------|--------|---------------|---------------------|--------------------|
| BT-LE(1Mbps) | - | - | - | - |
| 2402MHz | Pass | 500k | 692.029k | 1.046M |
| 2440MHz | Pass | 500k | 688.406k | 1.042M |
| 2480MHz | Pass | 500k | 695.652k | 1.046M |

Port X-N dB = Port X 6dB down bandwidth;
Port X-OBW = Port X 99% occupied bandwidth

BT-LE(1Mbps)

EBW-DTS

2402MHz

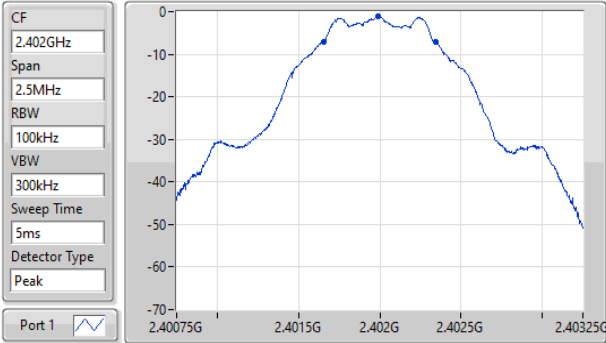

| 6dB(Hz) | Fl-6dB(Hz) | Fh-6dB(Hz) | OBW(Hz) | Fl-OBW(Hz) | Fh-OBW(Hz) | Limit(Hz) | Port |
|----------|------------|------------|---------|------------|------------|-----------|------|
| 692.029k | 2.401652G | 2.402344G | 1.046M | 2.401483G | 2.402528G | 500k | 1 |

BT-LE(1Mbps)

EBW-DTS

2440MHz

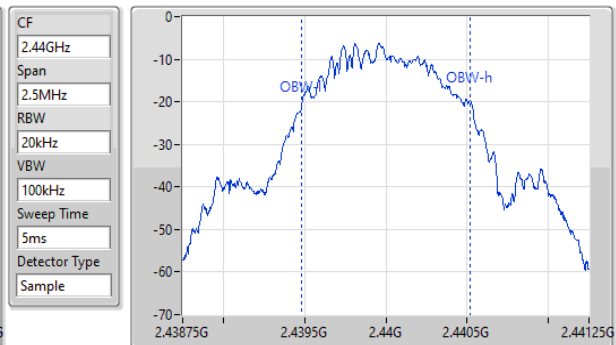
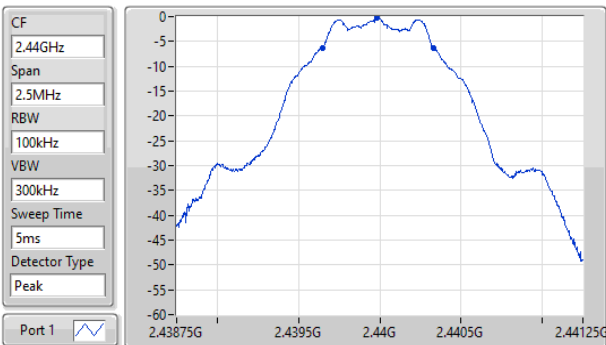

| 6dB(Hz) | Fl-6dB(Hz) | Fh-6dB(Hz) | OBW(Hz) | Fl-OBW(Hz) | Fh-OBW(Hz) | Limit(Hz) | Port |
|----------|------------|------------|---------|------------|------------|-----------|------|
| 688.406k | 2.439645G | 2.440333G | 1.042M | 2.439479G | 2.440521G | 500k | 1 |

BT-LE(1Mbps)

2480MHz

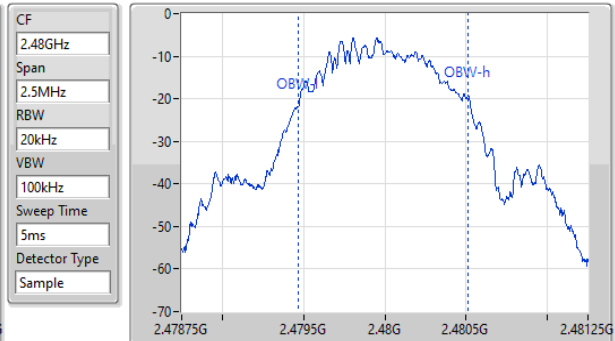
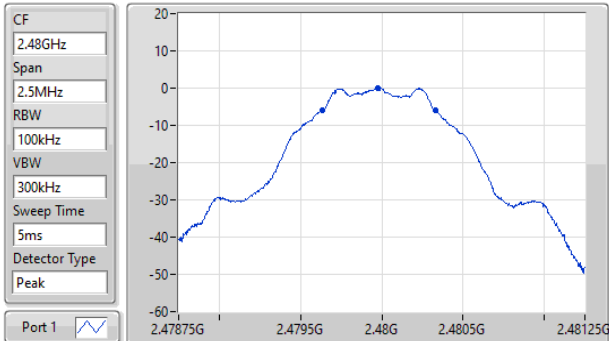

| 6dB(Hz) | Fl-6dB(Hz) | Fh-6dB(Hz) | OBW(Hz) | Fl-OBW(Hz) | Fh-OBW(Hz) | Limit(Hz) | Port |
|----------|------------|------------|---------|------------|------------|-----------|------|
| 695.652k | 2.479634G | 2.48033G | 1.046M | 2.479468G | 2.480514G | 500k | 1 |

3.3 RF Output Power

3.3.1 Limit of RF Output Power

Conducted power shall not exceed 1Watt.

Antenna gain $\leq 6\text{dBi}$, no any corresponding reduction is in output power limit.

3.3.2 Test Procedures

A broadband RF power meter is used for output power measurement. The video bandwidth of power meter is greater than DTS bandwidth of EUT. If duty cycle of test signal is not 100 %, trigger and gating function of power meter will be enabled to capture transmission burst for measuring output power.

3.3.3 Test Setup

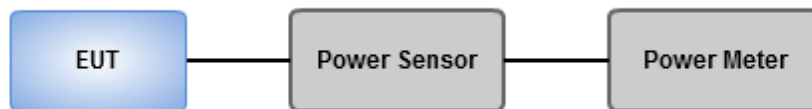

3.3.4 Test Result of Maximum Output Power

| | | | |
|--------------------------|------------|------------------|---------|
| Ambient Condition | 24°C / 63% | Tested By | Brad Wu |
|--------------------------|------------|------------------|---------|

Summary of Peak Conducted Output Power

| Mode | Power (dBm) | Power (W) |
|---------------|-------------|-----------|
| 2.4-2.4835GHz | - | - |
| BT-LE(1Mbps) | 2.15 | 0.00164 |

Result

| Mode | Result | Gain (dBi) | Power (dBm) | Power Limit (dBm) |
|--------------|--------|------------|-------------|-------------------|
| BT-LE(1Mbps) | - | - | - | - |
| 2402MHz | Pass | 2.70 | 1.05 | 30.00 |
| 2440MHz | Pass | 2.70 | 1.76 | 30.00 |
| 2480MHz | Pass | 2.70 | 2.15 | 30.00 |

DG = Directional Gain; Port X = Port X output power

Summary of Conducted (Average) Output Power

| Mode | Power (dBm) | Power (W) |
|---------------|-------------|-----------|
| 2.4-2.4835GHz | - | - |
| BT-LE(1Mbps) | 1.85 | 0.00153 |

Result

| Mode | Result | Gain (dBi) | Power (dBm) | Power Limit (dBm) |
|--------------|--------|------------|-------------|-------------------|
| BT-LE(1Mbps) | - | - | - | - |
| 2402MHz | Pass | 2.70 | 0.70 | - |
| 2440MHz | Pass | 2.70 | 1.44 | - |
| 2480MHz | Pass | 2.70 | 1.85 | - |

Note: Average power is for reference only.

3.4 Power Spectral Density

3.4.1 Limit of Power Spectral Density

Power spectral density shall not be greater than 8 dBm in any 3 kHz band.

3.4.2 Test Procedures

1. Set the RBW = 3 kHz, VBW = 10 kHz.
2. Detector = Peak, Sweep time = auto couple.
3. Trace mode = max hold, allow trace to fully stabilize.
4. Use the peak marker function to determine the maximum amplitude level.

3.4.3 Test Setup

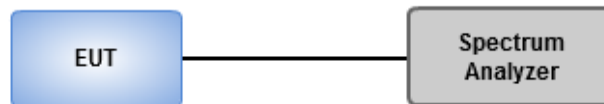

3.4.4 Test Result of Power Spectral Density

| | | | |
|--------------------------|------------|------------------|---------|
| Ambient Condition | 24°C / 63% | Tested By | Brad Wu |
|--------------------------|------------|------------------|---------|

Summary

| Mode | PD (dBm/3kHz) |
|---------------|------------------|
| 2.4-2.4835GHz | - |
| BT-LE(1Mbps) | -14.78 |

RBW = 3kHz;

Result

| Mode | Result | Antenna Gain (dBi) | PD (dBm/3kHz) | PD Limit (dBm/3kHz) |
|--------------|--------|-----------------------|------------------|------------------------|
| BT-LE(1Mbps) | - | - | - | - |
| 2402MHz | Pass | 2.70 | -16.06 | 8.00 |
| 2440MHz | Pass | 2.70 | -15.23 | 8.00 |
| 2480MHz | Pass | 2.70 | -14.78 | 8.00 |

PD =Maximum power density;

BT-LE(1Mbps)

PSD

2402MHz

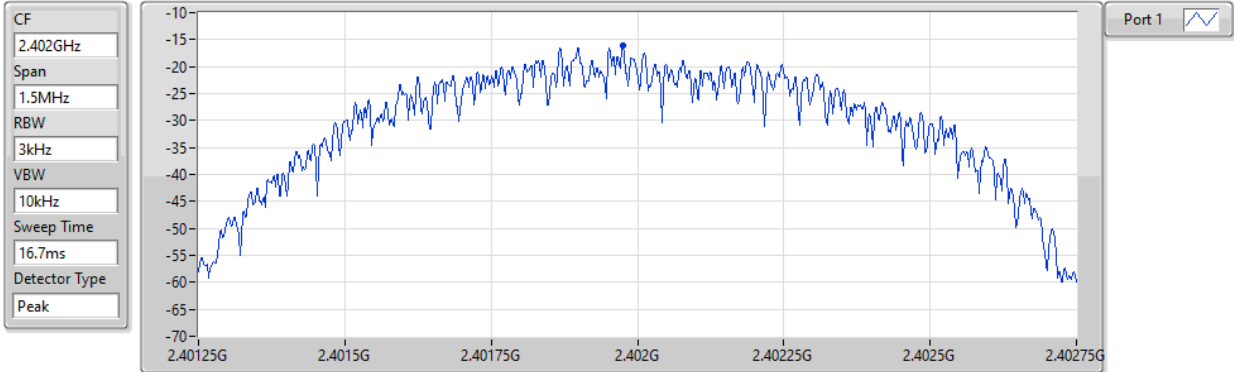

| Sum | PD | Port 1 |
|-----------|-----------|-----------|
| (dBm/RBW) | (dBm/RBW) | (dBm/RBW) |
| -16.06 | -16.06 | -16.06 |

BT-LE(1Mbps)

PSD

2440MHz

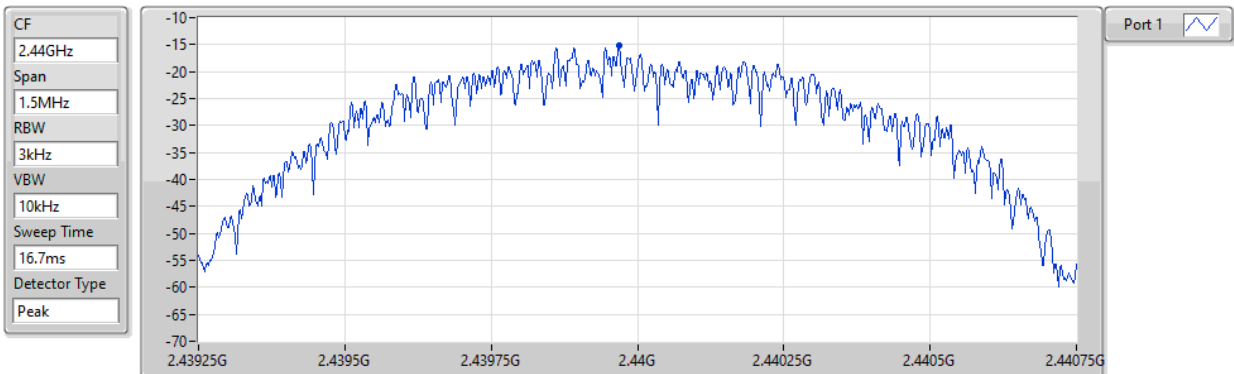

| Sum | PD | Port 1 |
|-----------|-----------|-----------|
| (dBm/RBW) | (dBm/RBW) | (dBm/RBW) |
| -15.23 | -15.23 | -15.23 |

BT-LE(1Mbps)

PSD

2480MHz

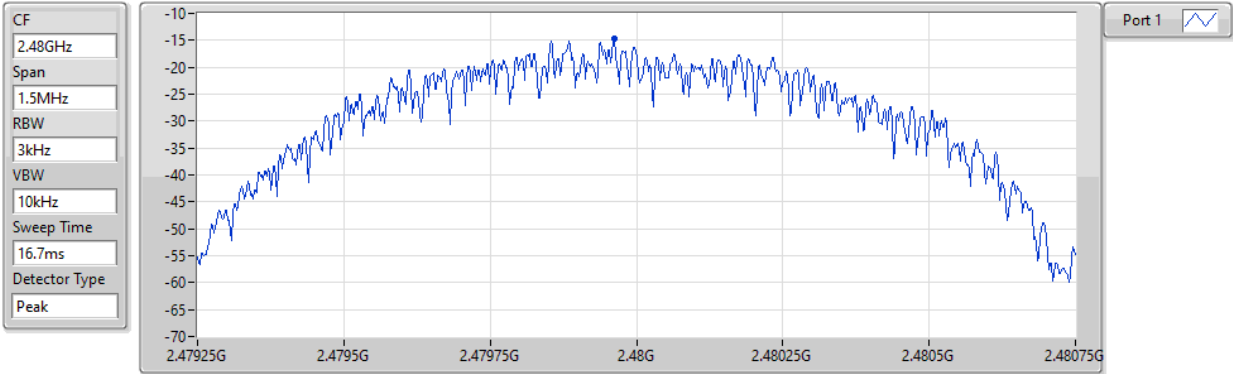

| Sum | PD | Port 1 |
|-----------|-----------|-----------|
| (dBm/RBW) | (dBm/RBW) | (dBm/RBW) |
| -14.78 | -14.78 | -14.78 |

3.5 Emissions in Restricted Frequency Bands

3.5.1 Limit of Emissions in Restricted Frequency Bands

| Restricted Band Emissions Limit | | | |
|---------------------------------|-----------------------|-------------------------|----------------------|
| Frequency Range (MHz) | Field Strength (uV/m) | Field Strength (dBuV/m) | Measure Distance (m) |
| 0.009~0.490 | 2400/F(kHz) | 48.5 - 13.8 | 300 |
| 0.490~1.705 | 24000/F(kHz) | 33.8 - 23 | 30 |
| 1.705~30.0 | 30 | 29 | 30 |
| 30~88 | 100 | 40 | 3 |
| 88~216 | 150 | 43.5 | 3 |
| 216~960 | 200 | 46 | 3 |
| Above 960 | 500 | 54 | 3 |

Note 1:
Quasi-Peak value is measured for frequency below 1GHz except for 9–90 kHz, 110–490 kHz frequency band. Peak and average value are measured for frequency above 1GHz. The limit on average radio frequency emission is as above table. The limit on peak radio frequency emissions is 20 dB above the maximum permitted average emission limit

Note 2:
Measurements may be performed at a distance other than what is specified provided. When performing measurements at a distance other than that specified, the results shall be extrapolated to the specified distance using an extrapolation factor as below, Frequency at or above 30 MHz: 20 dB/decade Frequency below 30 MHz: 40 dB/decade.

3.5.2 Test Procedures

1. Measurement is made at a semi-anechoic chamber that incorporates a turntable allowing a EUT rotation of 360°. A continuously-rotating, remotely-controlled turntable is installed at the test site to support the EUT and facilitate determination of the direction of maximum radiation for each EUT emission frequency. The EUT is placed at test table. For emissions testing at or below 1 GHz, the table height is 80 cm above the reference ground plane. For emission measurements above 1 GHz, the table height is 1.5 m
2. Measurement is made with the antenna positioned in both the horizontal and vertical planes of polarization. The measurement antenna is varied in height (1m ~ 4m) above the reference ground plane to obtain the maximum signal strength. Distance between EUT and antenna is 3 m.
3. This investigation is performed with the EUT rotated 360°, the antenna height scanned between 1 m and 4 m, and the antenna rotated to repeat the measurements for both the horizontal and vertical antenna polarizations.

Note:

1. 120kHz measurement bandwidth of test receiver and Quasi-peak detector is for radiated emission below 1GHz.
2. RBW=1MHz, VBW=3MHz and Peak detector is for peak measured value of radiated emission above 1GHz.
3. RBW=1MHz, VBW=1/T and Peak detector is for average measured value of radiated emission above 1GHz.

3.5.3 Test Setup

Radiated Emissions below 1 GHz

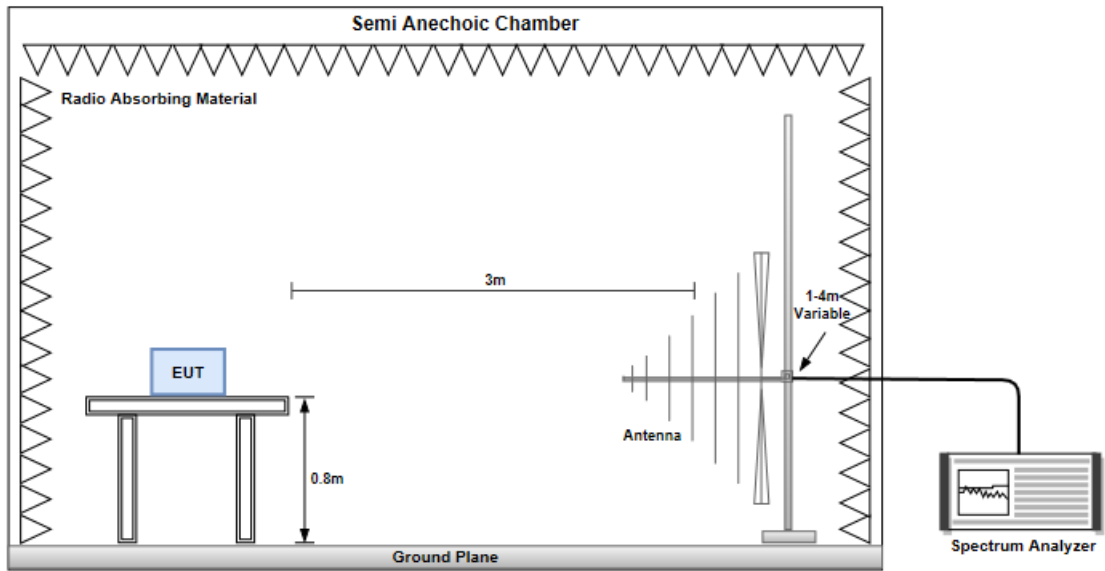

Radiated Emissions above 1 GHz

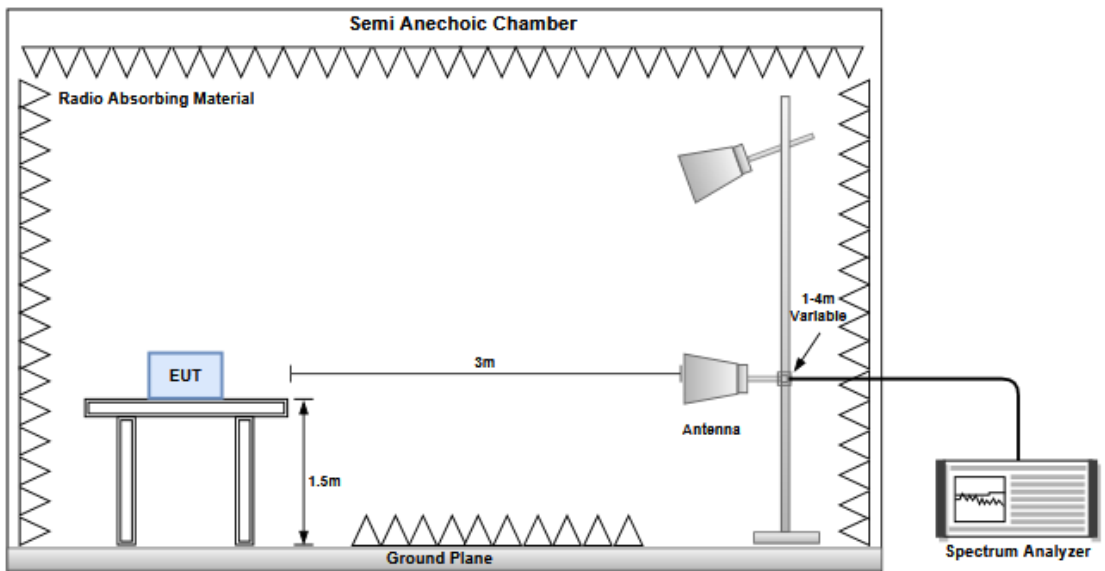

3.5.4 Transmitter Radiated Unwanted Emissions (Below 1GHz)

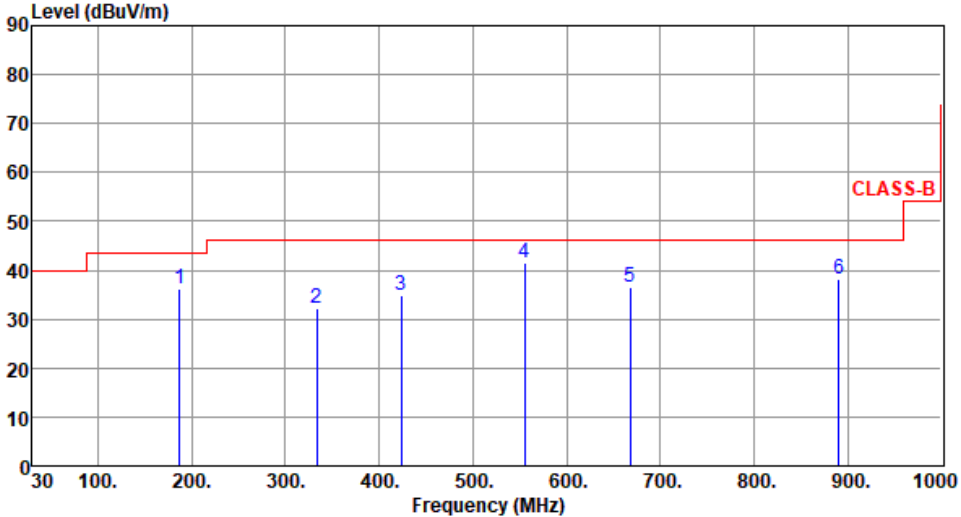
| Modulation | BT LE-1Mbps | Test Freq. (MHz) | 2480 | | | | | | | | | | | | | | | | | | | | | | | | | | | | | | | | | | | | | | | | | | | | | | | | | | | | | | | | | | | | | | | | | | | | | | |
|---|--|-----------------------------|-----------------|-----------------------------|-----------------------|----------------|-----------------------|-------------------|----------------------|-------------------|----------------------|---|--------|-------|-------|-------|-------|--------|------|-----|-----|---|--------|-------|-------|--------|-------|-------|------|-----|-----|---|--------|-------|-------|--------|-------|-------|------|-----|-----|---|--------|-------|-------|-------|-------|-------|------|-----|-----|---|--------|-------|-------|-------|-------|-------|------|-----|-----|---|--------|-------|-------|-------|-------|------|------|-----|-----|--|--|
| Polarization | Horizontal | Test Configuration | 1 | | | | | | | | | | | | | | | | | | | | | | | | | | | | | | | | | | | | | | | | | | | | | | | | | | | | | | | | | | | | | | | | | | | | | | |
| Test By : Akun Chung Temperature(°C):22 Humidity(%):65 | | | | | | | | | | | | | | | | | | | | | | | | | | | | | | | | | | | | | | | | | | | | | | | | | | | | | | | | | | | | | | | | | | | | | | | | | |
|  <p>The graph plots Level (dBuV/m) on the y-axis (0 to 90) against Frequency (MHz) on the x-axis (30 to 1000). A red line represents the Class-B limit, which is constant at 40 dBuV/m until 100 MHz, then steps up to 45 dBuV/m at 200 MHz, and to 50 dBuV/m at 900 MHz. Six blue vertical lines indicate emission peaks at 187.25 MHz (1), 333.75 MHz (2), 423.58 MHz (3), 555.52 MHz (4), 667.85 MHz (5), and 890.45 MHz (6). The emission levels are 36.27, 32.17, 35.03, 41.54, 36.53, and 38.15 dBuV/m respectively. The table below provides the detailed data for these peaks.</p> | | | | | | | | | | | | | | | | | | | | | | | | | | | | | | | | | | | | | | | | | | | | | | | | | | | | | | | | | | | | | | | | | | | | | | | | | |
| | <table border="1"> <thead> <tr> <th></th> <th>Freq. MHz</th> <th>Emission level dBuV/m</th> <th>Limit dBuV/m</th> <th>Margin dB</th> <th>SA reading dBuV</th> <th>Factor dB/m</th> <th>Remark</th> <th>ANT High cm</th> <th>Turn Table deg</th> </tr> </thead> <tbody> <tr> <td>1</td> <td>187.25</td> <td>36.27</td> <td>43.50</td> <td>-7.23</td> <td>47.43</td> <td>-11.16</td> <td>Peak</td> <td>---</td> <td>---</td> </tr> <tr> <td>2</td> <td>333.75</td> <td>32.17</td> <td>46.00</td> <td>-13.83</td> <td>39.28</td> <td>-7.11</td> <td>Peak</td> <td>---</td> <td>---</td> </tr> <tr> <td>3</td> <td>423.58</td> <td>35.03</td> <td>46.00</td> <td>-10.97</td> <td>40.11</td> <td>-5.08</td> <td>Peak</td> <td>---</td> <td>---</td> </tr> <tr> <td>4</td> <td>555.52</td> <td>41.54</td> <td>46.00</td> <td>-4.46</td> <td>43.75</td> <td>-2.21</td> <td>Peak</td> <td>---</td> <td>---</td> </tr> <tr> <td>5</td> <td>667.85</td> <td>36.53</td> <td>46.00</td> <td>-9.47</td> <td>36.69</td> <td>-0.16</td> <td>Peak</td> <td>---</td> <td>---</td> </tr> <tr> <td>6</td> <td>890.45</td> <td>38.15</td> <td>46.00</td> <td>-7.85</td> <td>34.52</td> <td>3.63</td> <td>Peak</td> <td>---</td> <td>---</td> </tr> </tbody> </table> | | Freq. MHz | Emission level dBuV/m | Limit dBuV/m | Margin dB | SA reading dBuV | Factor dB/m | Remark | ANT High cm | Turn Table deg | 1 | 187.25 | 36.27 | 43.50 | -7.23 | 47.43 | -11.16 | Peak | --- | --- | 2 | 333.75 | 32.17 | 46.00 | -13.83 | 39.28 | -7.11 | Peak | --- | --- | 3 | 423.58 | 35.03 | 46.00 | -10.97 | 40.11 | -5.08 | Peak | --- | --- | 4 | 555.52 | 41.54 | 46.00 | -4.46 | 43.75 | -2.21 | Peak | --- | --- | 5 | 667.85 | 36.53 | 46.00 | -9.47 | 36.69 | -0.16 | Peak | --- | --- | 6 | 890.45 | 38.15 | 46.00 | -7.85 | 34.52 | 3.63 | Peak | --- | --- | | |
| | Freq. MHz | Emission level dBuV/m | Limit dBuV/m | Margin dB | SA reading dBuV | Factor dB/m | Remark | ANT High cm | Turn Table deg | | | | | | | | | | | | | | | | | | | | | | | | | | | | | | | | | | | | | | | | | | | | | | | | | | | | | | | | | | | | | | | | |
| 1 | 187.25 | 36.27 | 43.50 | -7.23 | 47.43 | -11.16 | Peak | --- | --- | | | | | | | | | | | | | | | | | | | | | | | | | | | | | | | | | | | | | | | | | | | | | | | | | | | | | | | | | | | | | | | | |
| 2 | 333.75 | 32.17 | 46.00 | -13.83 | 39.28 | -7.11 | Peak | --- | --- | | | | | | | | | | | | | | | | | | | | | | | | | | | | | | | | | | | | | | | | | | | | | | | | | | | | | | | | | | | | | | | | |
| 3 | 423.58 | 35.03 | 46.00 | -10.97 | 40.11 | -5.08 | Peak | --- | --- | | | | | | | | | | | | | | | | | | | | | | | | | | | | | | | | | | | | | | | | | | | | | | | | | | | | | | | | | | | | | | | | |
| 4 | 555.52 | 41.54 | 46.00 | -4.46 | 43.75 | -2.21 | Peak | --- | --- | | | | | | | | | | | | | | | | | | | | | | | | | | | | | | | | | | | | | | | | | | | | | | | | | | | | | | | | | | | | | | | | |
| 5 | 667.85 | 36.53 | 46.00 | -9.47 | 36.69 | -0.16 | Peak | --- | --- | | | | | | | | | | | | | | | | | | | | | | | | | | | | | | | | | | | | | | | | | | | | | | | | | | | | | | | | | | | | | | | | |
| 6 | 890.45 | 38.15 | 46.00 | -7.85 | 34.52 | 3.63 | Peak | --- | --- | | | | | | | | | | | | | | | | | | | | | | | | | | | | | | | | | | | | | | | | | | | | | | | | | | | | | | | | | | | | | | | | |
| Note 1: Emission Level (dBuV/m) = SA Reading (dBuV) + Factor* (dB/m) *Factor includes antenna factor , cable loss and amplifier gain Note 2: Margin (dB) = Emission level (dBuV/m) – Limit (dBuV/m). Note 3: All spurious emissions below 30MHz are more than 20 dB below the limit. | | | | | | | | | | | | | | | | | | | | | | | | | | | | | | | | | | | | | | | | | | | | | | | | | | | | | | | | | | | | | | | | | | | | | | | | | |

| | | | |
|---------------------|-------------|---------------------------|------|
| Modulation | BT LE-1Mbps | Test Freq. (MHz) | 2480 |
| Polarization | Vertical | Test Configuration | 1 |

Test By :Akun Chung Temperature(°C):22 Humidity(%):65

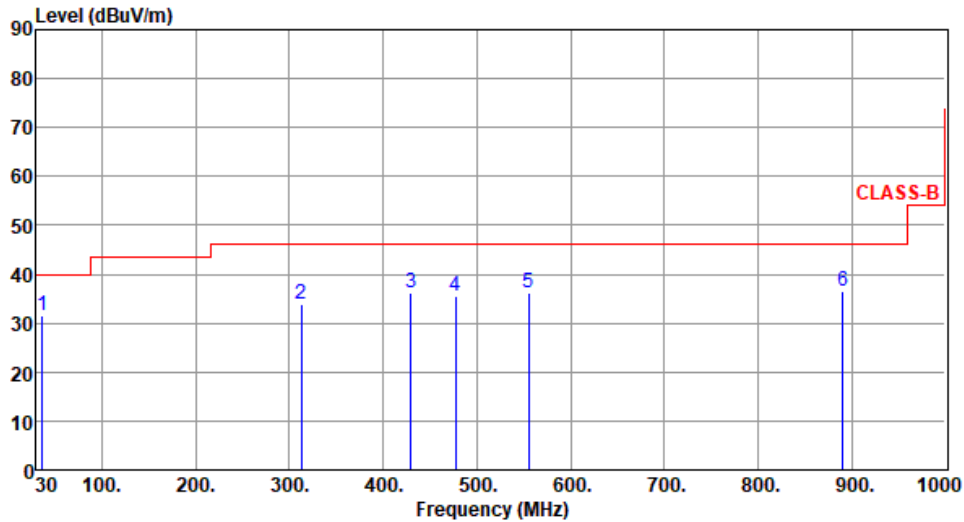

| | Freq. MHz | Emission level dBuV/m | Limit dBuV/m | Margin dB | SA reading dBuV | Factor dB/m | Remark | ANT High cm | Turn Table deg |
|---|--------------|-----------------------------|-----------------|--------------|-----------------------|----------------|--------|-------------------|----------------------|
| 1 | 36.57 | 31.57 | 40.00 | -8.43 | 40.65 | -9.08 | Peak | --- | --- |
| 2 | 312.85 | 33.95 | 46.00 | -12.05 | 41.59 | -7.64 | Peak | --- | --- |
| 3 | 429.58 | 36.22 | 46.00 | -9.78 | 41.05 | -4.83 | Peak | --- | --- |
| 4 | 477.28 | 35.45 | 46.00 | -10.55 | 39.16 | -3.71 | Peak | --- | --- |
| 5 | 555.63 | 36.15 | 46.00 | -9.85 | 38.36 | -2.21 | Peak | --- | --- |
| 6 | 890.44 | 36.55 | 46.00 | -9.45 | 32.92 | 3.63 | Peak | --- | --- |

Note 1: Emission Level (dBuV/m) = SA Reading (dBuV) + Factor* (dB/m)

*Factor includes antenna factor , cable loss and amplifier gain

Note 2: Margin (dB) = Emission level (dBuV/m) – Limit (dBuV/m).

Note 3: All spurious emissions below 30MHz are more than 20 dB below the limit.

| | | | |
|---------------------|-------------|---------------------------|------|
| Modulation | BT LE-1Mbps | Test Freq. (MHz) | 2480 |
| Polarization | Horizontal | Test Configuration | 2 |

Test By : Akun Chung Temperature(°C): 22 Humidity(%): 65

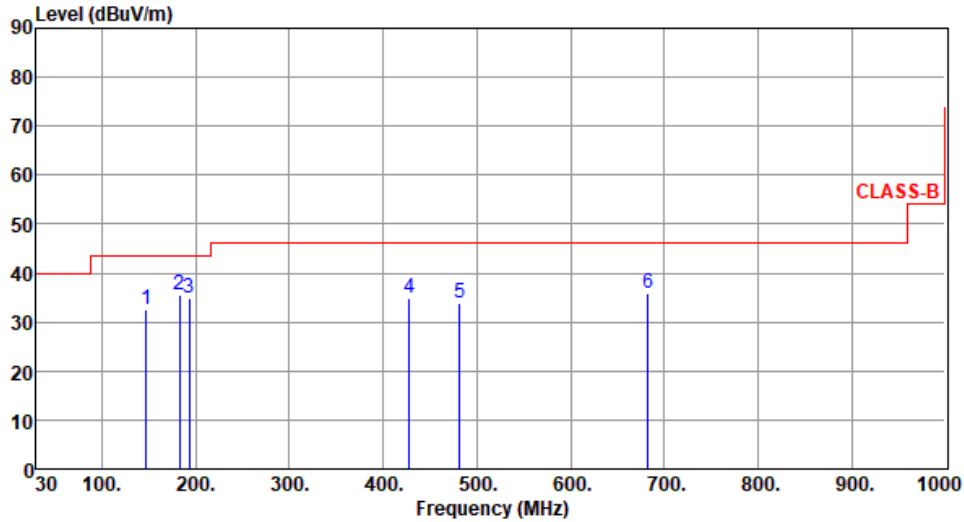

| | Freq. MHz | Emission level dBuV/m | Limit dBuV/m | Margin dB | SA reading dBuV | Factor dB/m | Remark | ANT High cm | Turn Table deg |
|---|--------------|-----------------------------|-----------------|--------------|-----------------------|----------------|--------|-------------------|----------------------|
| 1 | 147.25 | 32.46 | 43.50 | -11.04 | 41.31 | -8.85 | Peak | --- | --- |
| 2 | 182.44 | 35.44 | 43.50 | -8.06 | 46.05 | -10.61 | Peak | --- | --- |
| 3 | 193.25 | 34.73 | 43.50 | -8.77 | 46.40 | -11.67 | Peak | --- | --- |
| 4 | 427.85 | 34.95 | 46.00 | -11.05 | 39.85 | -4.90 | Peak | --- | --- |
| 5 | 481.54 | 33.77 | 46.00 | -12.23 | 37.42 | -3.65 | Peak | --- | --- |
| 6 | 682.25 | 35.76 | 46.00 | -10.24 | 35.84 | -0.08 | Peak | --- | --- |

Note 1: Emission Level (dBuV/m) = SA Reading (dBuV) + Factor* (dB/m)

*Factor includes antenna factor, cable loss and amplifier gain

Note 2: Margin (dB) = Emission level (dBuV/m) – Limit (dBuV/m).

Note 3: All spurious emissions below 30MHz are more than 20 dB below the limit.

| | | | |
|---------------------|-------------|---------------------------|------|
| Modulation | BT LE-1Mbps | Test Freq. (MHz) | 2480 |
| Polarization | Vertical | Test Configuration | 2 |

Test By :Akun Chung Temperature(°C):22 Humidity(%):65

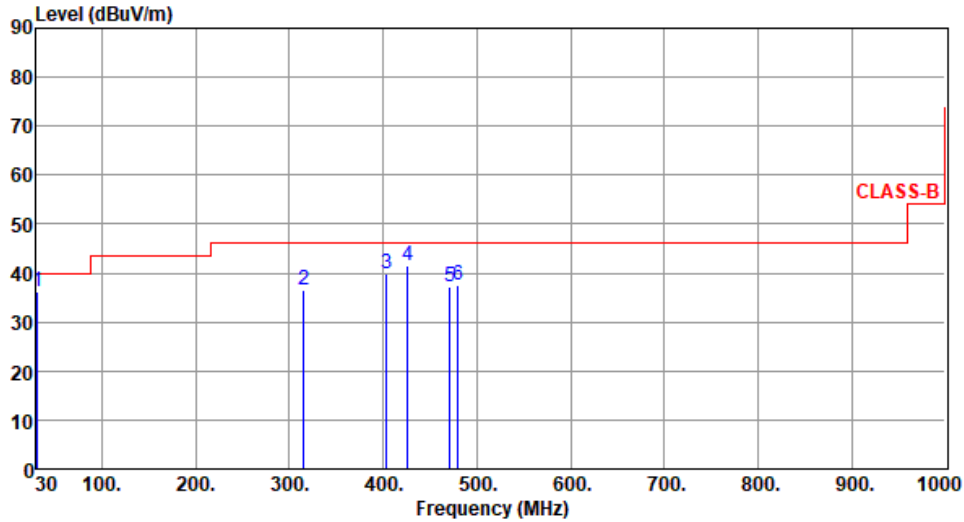

| | Freq. MHz | Emission level dBuV/m | Limit dBuV/m | Margin dB | SA reading dBuV | Factor dB/m | Remark | ANT High cm | Turn Table deg |
|---|--------------|-----------------------------|-----------------|--------------|-----------------------|----------------|--------|-------------------|----------------------|
| 1 | 31.21 | 36.29 | 40.00 | -3.71 | 46.01 | -9.72 | Peak | --- | --- |
| 2 | 315.40 | 36.41 | 46.00 | -9.59 | 43.94 | -7.53 | Peak | --- | --- |
| 3 | 403.63 | 39.82 | 46.00 | -6.18 | 45.54 | -5.72 | Peak | --- | --- |
| 4 | 426.25 | 41.42 | 46.00 | -4.58 | 46.39 | -4.97 | Peak | --- | --- |
| 5 | 471.44 | 37.26 | 46.00 | -8.74 | 41.10 | -3.84 | Peak | --- | --- |
| 6 | 479.52 | 37.60 | 46.00 | -8.40 | 41.27 | -3.67 | Peak | --- | --- |

Note 1: Emission Level (dBuV/m) = SA Reading (dBuV) + Factor* (dB/m)

*Factor includes antenna factor , cable loss and amplifier gain

Note 2: Margin (dB) = Emission level (dBuV/m) – Limit (dBuV/m).

Note 3: All spurious emissions below 30MHz are more than 20 dB below the limit.

3.5.5 Transmitter Radiated Unwanted Emissions (Above 1GHz)

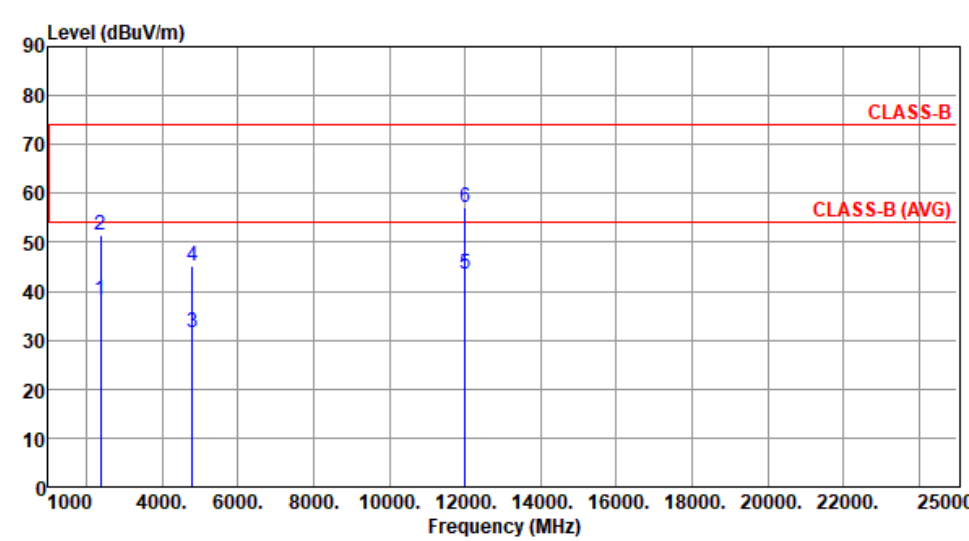
| | | | | | | | | | |
|---|-------------|-------------------------|--------|--------|------------|--------|---------|----------|------------|
| Modulation | BT LE-1Mbps | Test Freq. (MHz) | 2402 | | | | | | |
| Polarization | Horizontal | | | | | | | | |
| Test By :BRAD WU Temperature(°C):23 Humidity(%):62 | | | | | | | | | |
|  | | | | | | | | | |
| | Freq. | Emission level | Limit | Margin | SA reading | Factor | Remark | ANT High | Turn Table |
| | MHz | dBuV/m | dBuV/m | dB | dBuV | dB/m | | cm | deg |
| 1 | 2390.00 | 38.35 | 54.00 | -15.65 | 41.14 | -2.79 | Average | 103 | 309 |
| 2 | 2390.00 | 51.52 | 74.00 | -22.48 | 54.31 | -2.79 | Peak | 103 | 309 |
| 3 | 4804.00 | 31.65 | 54.00 | -22.35 | 28.15 | 3.50 | Average | 100 | 29 |
| 4 | 4804.00 | 45.32 | 74.00 | -28.68 | 41.82 | 3.50 | Peak | 100 | 29 |
| 5 | 12010.00 | 43.49 | 54.00 | -10.51 | 29.22 | 14.27 | Average | 100 | 45 |
| 6 | 12010.00 | 57.22 | 74.00 | -16.78 | 42.95 | 14.27 | Peak | 100 | 45 |

Note 1: Emission Level (dBuV/m) = SA Reading (dBuV) + Factor* (dB/m)
 *Factor includes antenna factor , cable loss and amplifier gain
 Note 2: Margin (dB) = Emission level (dBuV/m) – Limit (dBuV/m).

| | | | |
|---------------------|-------------|-------------------------|------|
| Modulation | BT LE-1Mbps | Test Freq. (MHz) | 2402 |
| Polarization | Vertical | | |

Test By :BRAD WU Temperature(°C):23 Humidity(%):62

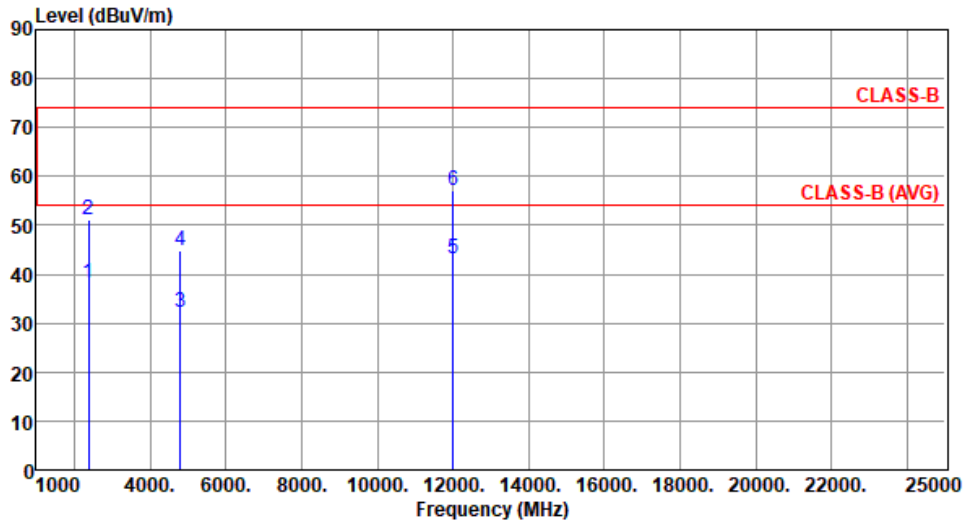

| | Freq. MHz | Emission level dBUV/m | Limit dBUV/m | Margin dB | SA reading dBUV | Factor dB/m | Remark | ANT High cm | Turn Table deg |
|---|--------------|-----------------------------|-----------------|--------------|-----------------------|----------------|---------|-------------------|----------------------|
| 1 | 2390.00 | 38.22 | 54.00 | -15.78 | 41.01 | -2.79 | Average | 313 | 154 |
| 2 | 2390.00 | 51.15 | 74.00 | -22.85 | 53.94 | -2.79 | Peak | 313 | 154 |
| 3 | 4804.00 | 32.21 | 54.00 | -21.79 | 28.71 | 3.50 | Average | 100 | 35 |
| 4 | 4804.00 | 44.84 | 74.00 | -29.16 | 41.34 | 3.50 | Peak | 100 | 35 |
| 5 | 12010.00 | 43.26 | 54.00 | -10.74 | 28.99 | 14.27 | Average | 100 | 21 |
| 6 | 12010.00 | 57.04 | 74.00 | -16.96 | 42.77 | 14.27 | Peak | 100 | 21 |

Note 1: Emission Level (dBUV/m) = SA Reading (dBUV) + Factor* (dB/m)

*Factor includes antenna factor , cable loss and amplifier gain

Note 2: Margin (dB) = Emission level (dBUV/m) – Limit (dBUV/m).

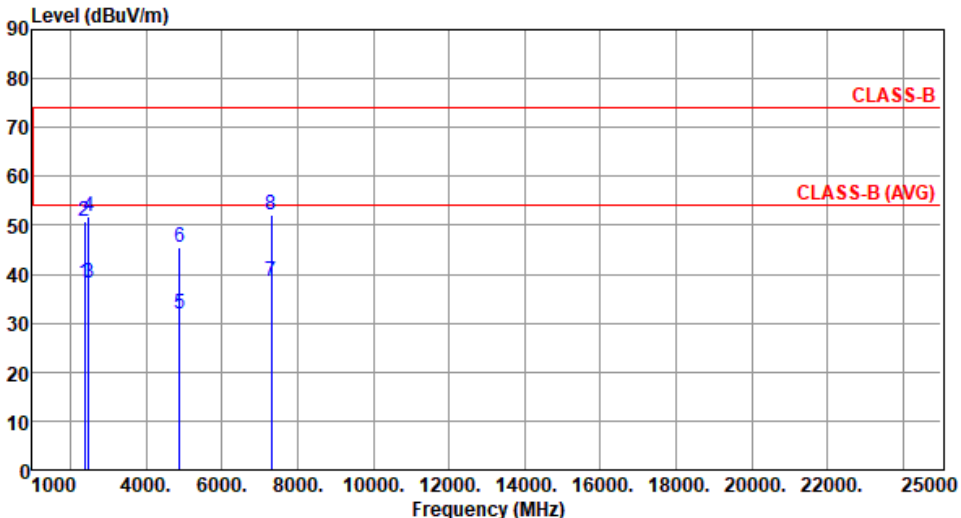
| | | | | | | | | | |
|---|-------------|-------------------------|-----------------|--------|------------|--------|---------|----------|------------|
| Modulation | BT LE-1Mbps | Test Freq. (MHz) | 2440 | | | | | | |
| Polarization | Horizontal | | | | | | | | |
| Test By | :BRAD WU | Temperature(°C):23 | Humidity(%) :62 | | | | | | |
|  | | | | | | | | | |
| | Freq. | Emission level | Limit | Margin | SA reading | Factor | Remark | ANT High | Turn Table |
| | MHz | dBuV/m | dBuV/m | dB | dBuV | dB/m | | cm | deg |
| 1 | 2390.00 | 38.34 | 54.00 | -15.66 | 41.13 | -2.79 | Average | 102 | 326 |
| 2 | 2390.00 | 50.94 | 74.00 | -23.06 | 53.73 | -2.79 | Peak | 102 | 326 |
| 3 | 2483.50 | 38.25 | 54.00 | -15.75 | 40.99 | -2.74 | Average | 102 | 326 |
| 4 | 2483.50 | 51.69 | 74.00 | -22.31 | 54.43 | -2.74 | Peak | 102 | 326 |
| 5 | 4880.00 | 31.86 | 54.00 | -22.14 | 28.39 | 3.47 | Average | 100 | 33 |
| 6 | 4880.00 | 45.52 | 74.00 | -28.48 | 42.05 | 3.47 | Peak | 100 | 33 |
| 7 | 7320.00 | 38.36 | 54.00 | -15.64 | 29.34 | 9.02 | Average | 100 | 48 |
| 8 | 7320.00 | 52.15 | 74.00 | -21.85 | 43.13 | 9.02 | Peak | 100 | 48 |
| <p>Note 1: Emission Level (dBuV/m) = SA Reading (dBuV) + Factor* (dB/m) *Factor includes antenna factor , cable loss and amplifier gain Note 2: Margin (dB) = Emission level (dBuV/m) – Limit (dBuV/m).</p> | | | | | | | | | |

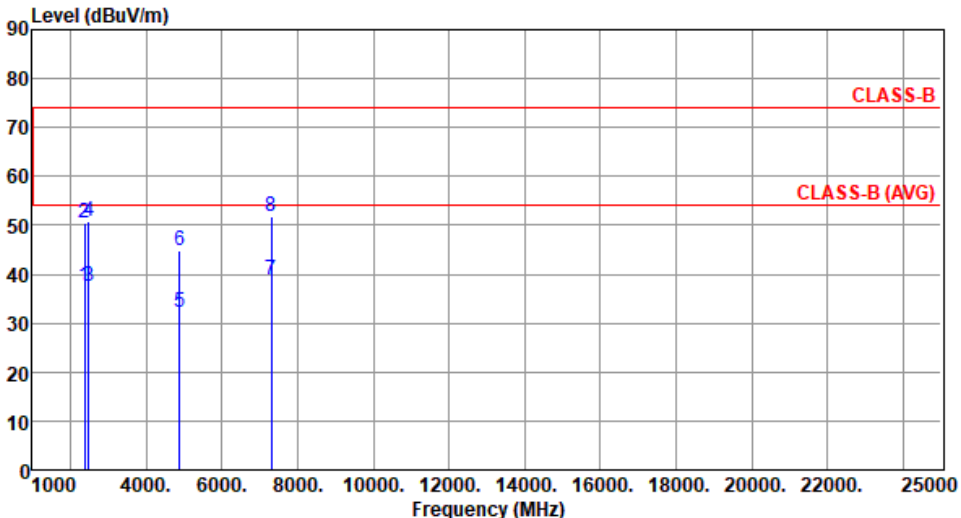
| | | | | | | | | | |
|---|--------------|-----------------------------|-----------------|--------------|-----------------------|----------------|---------|-------------------|----------------------|
| Modulation | BT LE-1Mbps | Test Freq. (MHz) | 2440 | | | | | | |
| Polarization | Vertical | | | | | | | | |
| Test By | :BRAD WU | Temperature(°C):23 | Humidity(%) :62 | | | | | | |
|  | | | | | | | | | |
| | Freq. MHz | Emission level dBuV/m | Limit dBuV/m | Margin dB | SA reading dBuV | Factor dB/m | Remark | ANT High cm | Turn Table deg |
| 1 | 2390.00 | 37.58 | 54.00 | -16.42 | 40.37 | -2.79 | Average | 305 | 156 |
| 2 | 2390.00 | 50.54 | 74.00 | -23.46 | 53.33 | -2.79 | Peak | 305 | 156 |
| 3 | 2483.50 | 37.38 | 54.00 | -16.62 | 40.12 | -2.74 | Average | 305 | 156 |
| 4 | 2483.50 | 50.73 | 74.00 | -23.27 | 53.47 | -2.74 | Peak | 305 | 156 |
| 5 | 4880.00 | 32.36 | 54.00 | -21.64 | 28.89 | 3.47 | Average | 100 | 52 |
| 6 | 4880.00 | 44.85 | 74.00 | -29.15 | 41.38 | 3.47 | Peak | 100 | 52 |
| 7 | 7320.00 | 38.82 | 54.00 | -15.18 | 29.80 | 9.02 | Average | 100 | 39 |
| 8 | 7320.00 | 51.75 | 74.00 | -22.25 | 42.73 | 9.02 | Peak | 100 | 39 |
| <p>Note 1: Emission Level (dBuV/m) = SA Reading (dBuV) + Factor* (dB/m) *Factor includes antenna factor , cable loss and amplifier gain Note 2: Margin (dB) = Emission level (dBuV/m) – Limit (dBuV/m).</p> | | | | | | | | | |

| | | | |
|---------------------|-------------|-------------------------|------|
| Modulation | BT LE-1Mbps | Test Freq. (MHz) | 2480 |
| Polarization | Horizontal | | |

Test By :BRAD WU Temperature(°C):23 Humidity(%):62

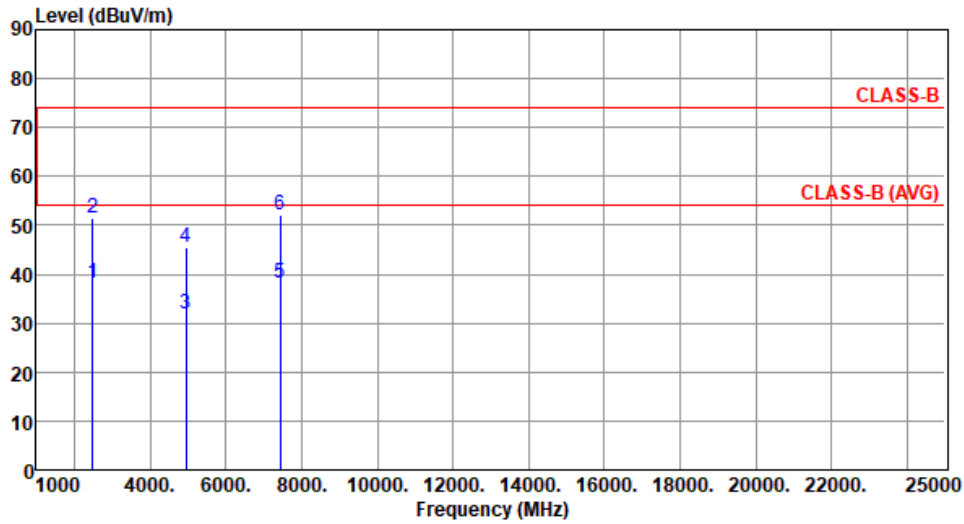

| | Freq. MHz | Emission level dBuV/m | Limit dBuV/m | Margin dB | SA reading dBuV | Factor dB/m | Remark | ANT High cm | Turn Table deg |
|---|--------------|-----------------------------|-----------------|--------------|-----------------------|----------------|---------|-------------------|----------------------|
| 1 | 2483.50 | 38.16 | 54.00 | -15.84 | 40.90 | -2.74 | Average | 101 | 341 |
| 2 | 2483.50 | 51.35 | 74.00 | -22.65 | 54.09 | -2.74 | Peak | 101 | 341 |
| 3 | 4960.00 | 31.77 | 54.00 | -22.23 | 28.09 | 3.68 | Average | 100 | 22 |
| 4 | 4960.00 | 45.41 | 74.00 | -28.59 | 41.73 | 3.68 | Peak | 100 | 22 |
| 5 | 7440.00 | 38.29 | 54.00 | -15.71 | 29.31 | 8.98 | Average | 100 | 55 |
| 6 | 7440.00 | 52.07 | 74.00 | -21.93 | 43.09 | 8.98 | Peak | 100 | 55 |

Note 1: Emission Level (dBuV/m) = SA Reading (dBuV) + Factor* (dB/m)

*Factor includes antenna factor , cable loss and amplifier gain

Note 2: Margin (dB) = Emission level (dBuV/m) – Limit (dBuV/m).

| | | | |
|---------------------|-------------|-------------------------|------|
| Modulation | BT LE-1Mbps | Test Freq. (MHz) | 2480 |
| Polarization | Vertical | | |

Test By :BRAD WU Temperature(°C):23 Humidity(%):62

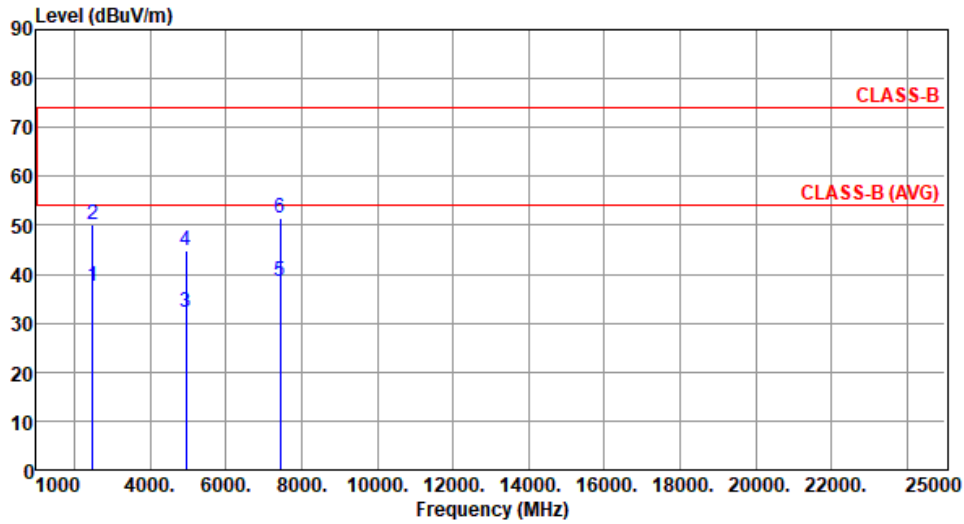

| | Freq. MHz | Emission level dBuV/m | Limit dBuV/m | Margin dB | SA reading dBuV | Factor dB/m | Remark | ANT High cm | Turn Table deg |
|---|--------------|-----------------------------|-----------------|--------------|-----------------------|----------------|---------|-------------------|----------------------|
| 1 | 2483.50 | 37.40 | 54.00 | -16.60 | 40.14 | -2.74 | Average | 294 | 134 |
| 2 | 2483.50 | 50.28 | 74.00 | -23.72 | 53.02 | -2.74 | Peak | 294 | 134 |
| 3 | 4960.00 | 32.13 | 54.00 | -21.87 | 28.45 | 3.68 | Average | 100 | 36 |
| 4 | 4960.00 | 44.74 | 74.00 | -29.26 | 41.06 | 3.68 | Peak | 100 | 36 |
| 5 | 7440.00 | 38.61 | 54.00 | -15.39 | 29.63 | 8.98 | Average | 100 | 41 |
| 6 | 7440.00 | 51.64 | 74.00 | -22.36 | 42.66 | 8.98 | Peak | 100 | 41 |

Note 1: Emission Level (dBuV/m) = SA Reading (dBuV) + Factor* (dB/m)

*Factor includes antenna factor , cable loss and amplifier gain

Note 2: Margin (dB) = Emission level (dBuV/m) – Limit (dBuV/m).

3.6 Emissions in non-restricted Frequency Bands

3.6.1 Emissions in non-restricted frequency bands limit

Peak power in any 100 kHz bandwidth outside of the authorized frequency band shall be attenuated by at least 20 dB relative to the maximum in-band peak PSD level in 100 kHz.

3.6.2 Test Procedures

Reference level measurement

1. Set RBW=100kHz, VBW = 300kHz , Detector = Peak, Sweep time = Auto
2. Trace = max hold , Allow Trace to fully stabilize
3. Use the peak marker function to determine the maximum PSD level

Emission level measurement

1. Set RBW=100kHz, VBW = 300kHz , Detector = Peak, Sweep time = Auto
2. Trace = max hold , Allow Trace to fully stabilize
3. Scan Frequency range is up to 25GHz
4. Use the peak marker function to determine the maximum amplitude level

3.6.3 Test Setup

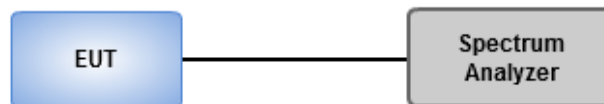

3.6.4 Test Result of Emissions in non-restricted Frequency Bands

| | | | |
|-------------------|------------|-----------|---------|
| Ambient Condition | 24°C / 63% | Tested By | Brad Wu |
|-------------------|------------|-----------|---------|

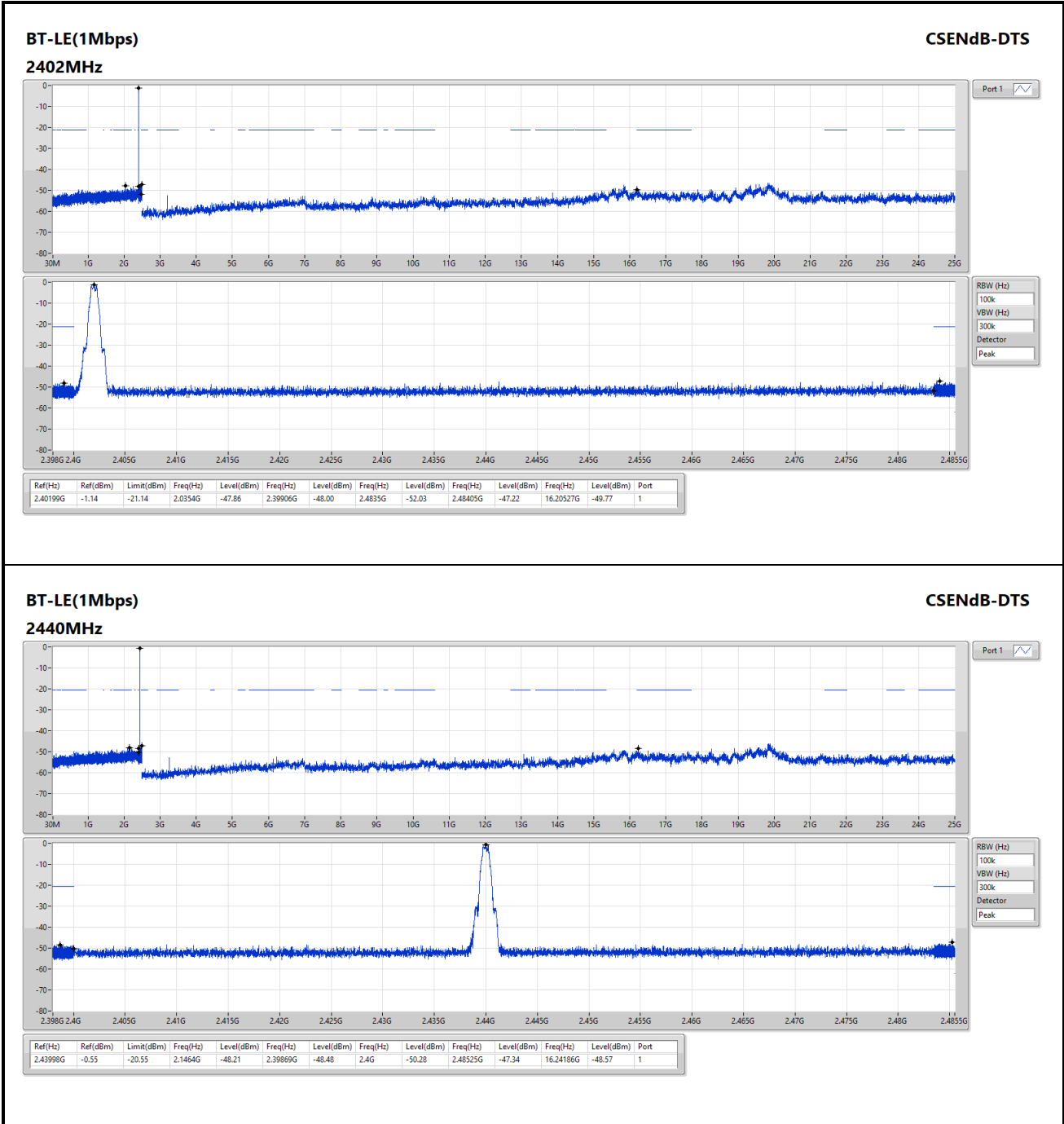

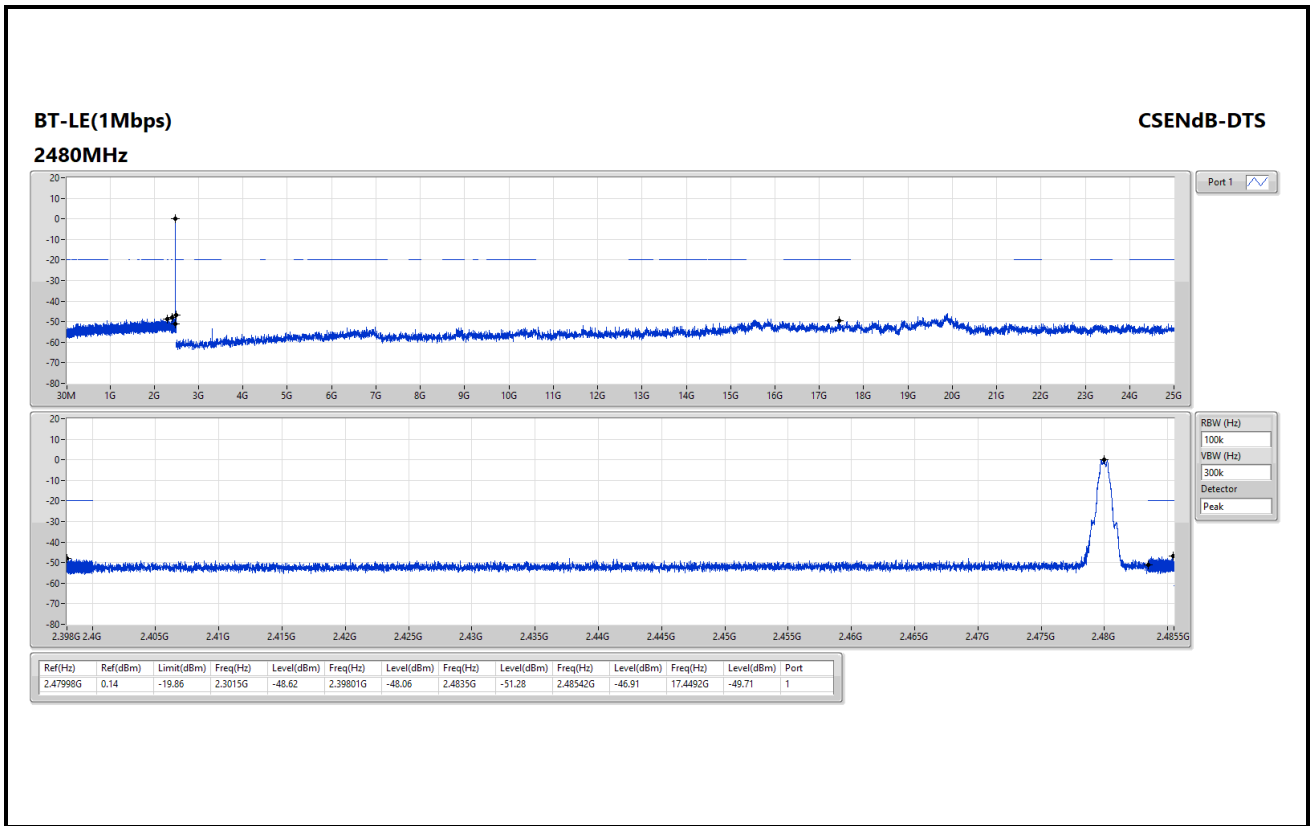

4 Test laboratory information

Established in 2012, ICC provides foremost EMC & RF Testing and advisory consultation services by our skilled engineers and technicians. Our services employ a wide variety of advanced edge test equipment and one of the widest certification extents in the business.

International Certification Corporation (EMC and Wireless Communication Laboratory), it is our definitive objective is to institute long term, trust-based associations with our clients. The expectation we set up with our clients is based on outstanding service, practical expertise and devotion to a certified value structure. Our passion is to grant our clients with best EMC / RF services by oriented knowledgeable and accommodating staff.

Our Test sites are located at Linkou District and Kwei Shan District. Location map can be found on our website <http://www.icertifi.com.tw>.

Linkou

Tel: 886-2-2601-1640

No.30-2, Ding Fwu Tsuen, Lin Kou
District, New Taipei City, Taiwan
(R.O.C.)

Kwei Shan

Tel: 886-3-271-8666

No.3-1, Lane 6, Wen San 3rd
St., Kwei Shan Dist., Tao Yuan
City 33381, Taiwan (R.O.C.)

Kwei Shan Site II

Tel: 886-3-271-8640

No.14-1, Lane 19, Wen San 3rd
St., Kwei Shan Dist., Tao Yuan
City 333, Taiwan (R.O.C.)

If you have any suggestion, please feel free to contact us as below information.

Tel: 886-3-271-8666

Fax: 886-3-318-0155

Email: ICC_Service@icertifi.com.tw

==END==