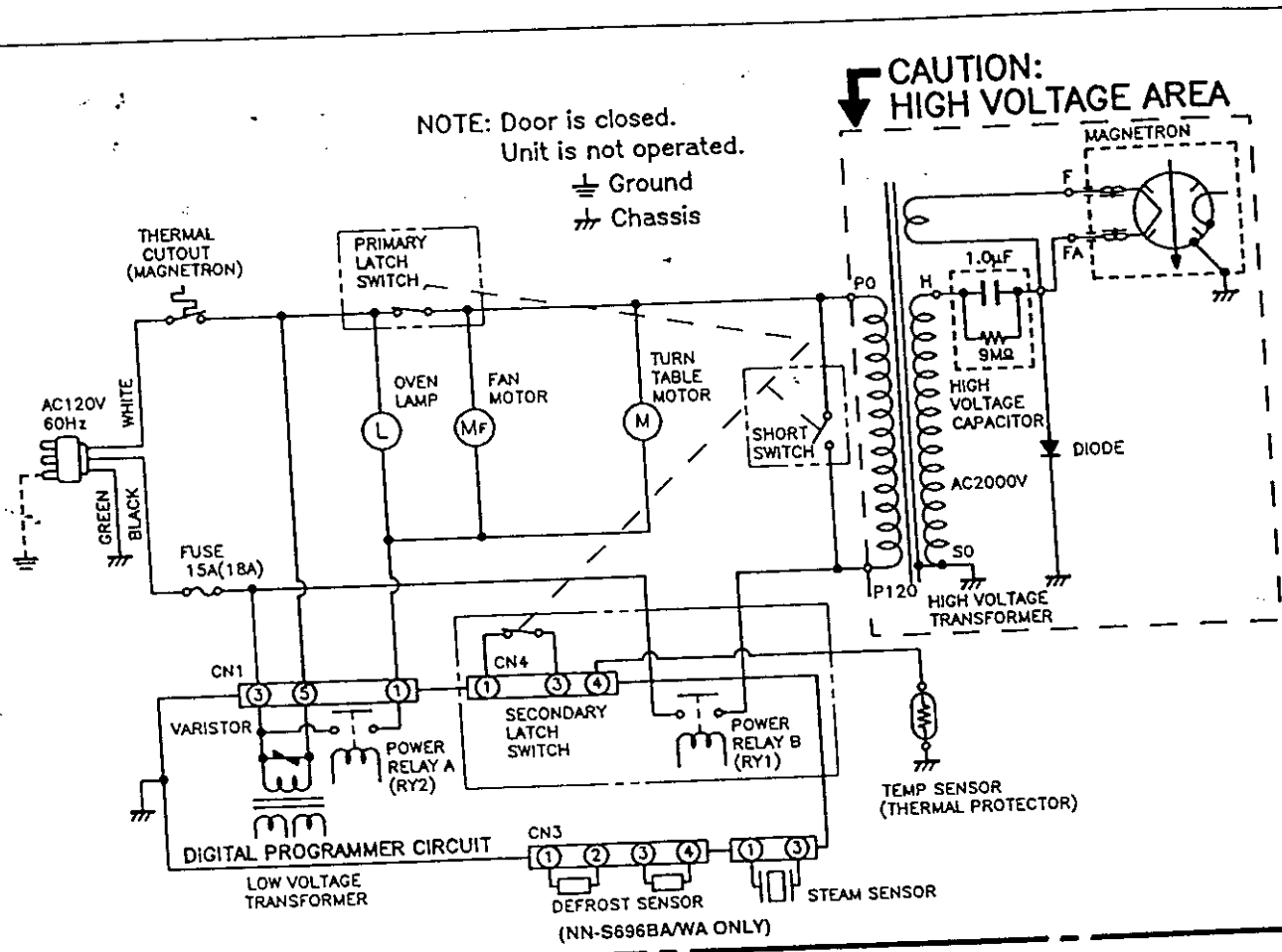
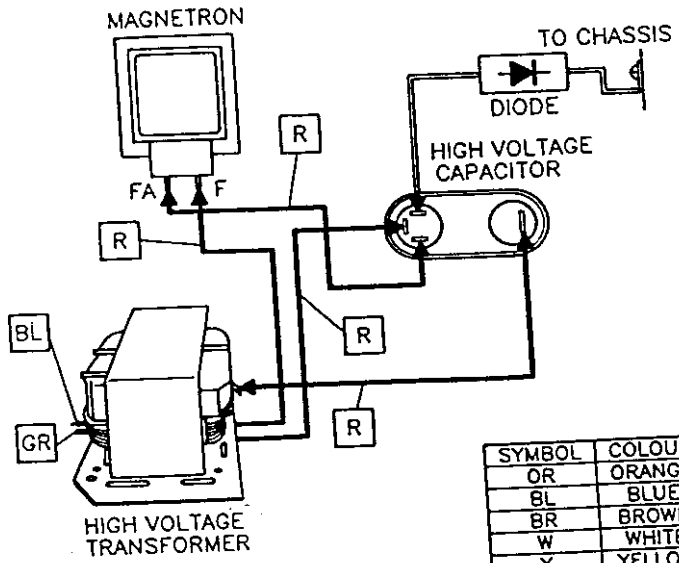
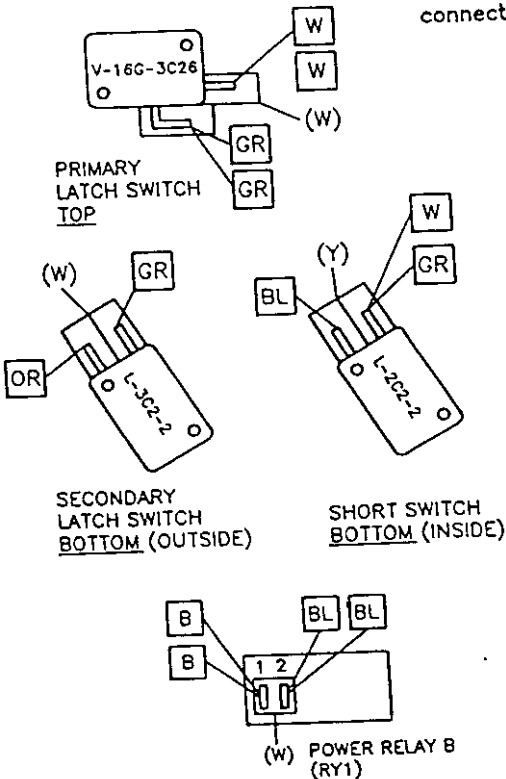

Exhibit 4
SCHEMATIC DIAGRAM (APH)



WIRING DIAGRAM

NOTE: *When replacing, check the lead wire colour as shown.
*Colours shown by () indicate colours of lead wire connector housing.



SYMBOL	COLOUR
OR	ORANGE
BL	BLUE
BR	BROWN
W	WHITE
Y	YELLOW
R	RED
GR	GRAY
B	BLACK

S-864APH
88-010