

R704
C703-C704
C708-C710
Q702
J719

Missing number

: 1%

ChipJPR J701
5mmJPR J711-J718, J720-J726, R729
10mmJPR J731-J737
15mmJPR J741-J742

R701-R703, R705-R757
C701, C702, C705-C707, C711-C738
D701-D709
Q701, Q703-Q706
ZD701-ZD703

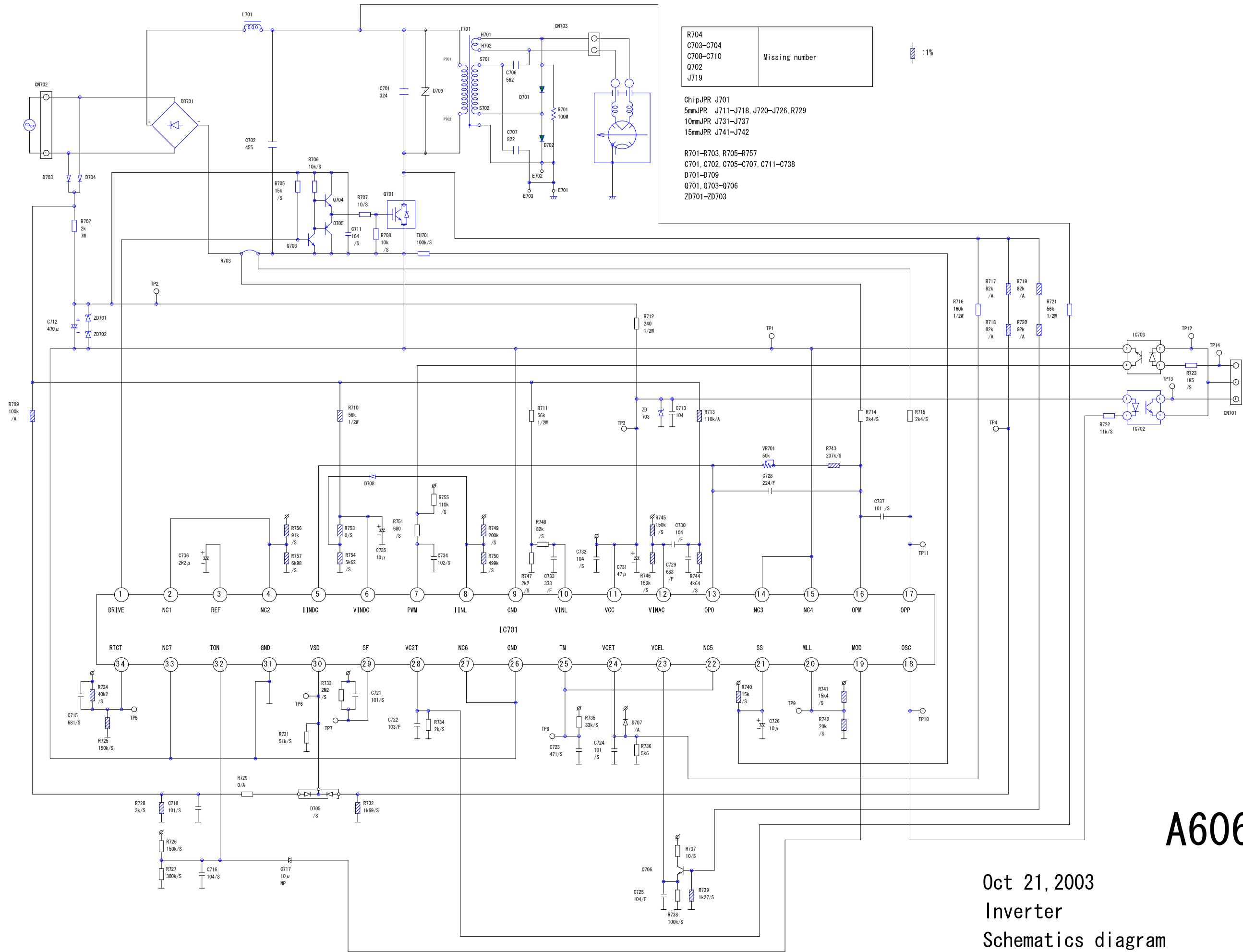

A606Y6G0

Oct 21, 2003
Inverter
Schematics diagram

1 SCHEMATIC DIAGRAM

1.1. APH NN-H765 (1.6 cft)

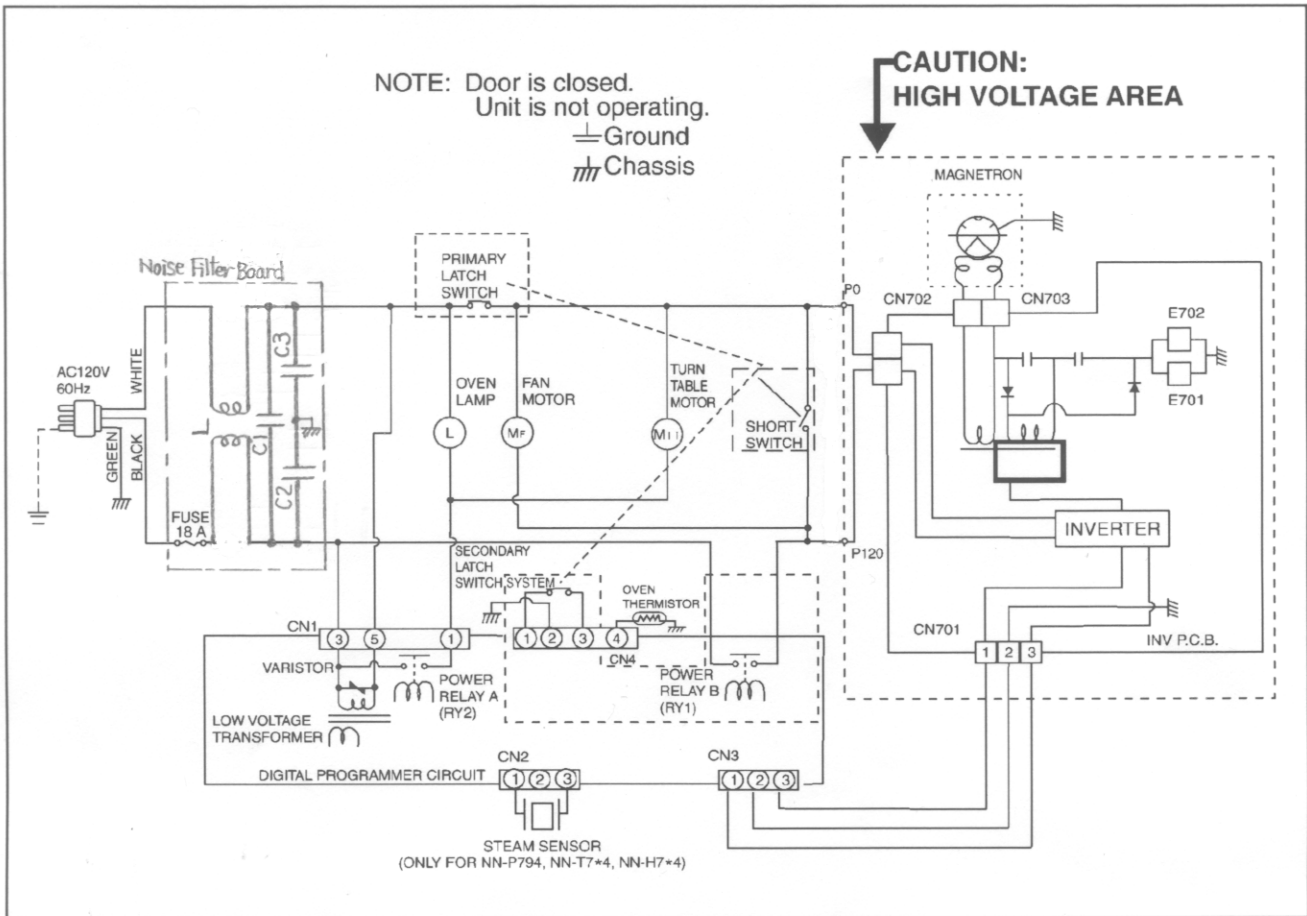

WIRING DIAGRAM (APH)

NOTE: * When replacing, check the lead wire color as shown.
* Colors shown by () indicate colors of lead wire connector housing.

