

Designated by Ministry of international Trade and industry

KANSAI ELECTRONIC INDUSTRY DEVELOPMENT CENTER

HEAD OFFICE
6-8-7 NISHITENMA
KITA-KU OSAKA 530-0047 JAPAN



IKOMA TESTING LABORATORY
12128 TAKAYAMA-CHO
IKOMA-CITY NARA 630-0101 JAPAN

Corporate Juridical Person

TEST REPORT

Report No.A-061-99-A

Date: 25 October 1999

This test report is to certify that the tested device properly complies with the requirements of:

FCC Rules and Regulations Part 15 Subpart B Unintentional Radiators.

All the tests necessary to show compliance to the requirements were performed and these results met the specifications of requirement. The results of this report should not be construed to imply compliance of equipment other than that, which was tested. Unless the laboratory permission, this report should not be copied in part.

1. Applicant

Company Name : Matsushita Electric Industrial Co., Ltd.
ADD Group, Storage Device Business Department
Mailing Address : 1-15 Matsuo-cho, Kadoma, Osaka, 571-8504 Japan

2. Identification of Tested Device

Type of Device : Digital Device
Kind of Equipment Authorization : : DoC : Certification : Verification
FCC ID : ACJODSDLFD211
Device Name : DVD-RAM Drive
Trade Name : Non Brand
Model Number : LF-D211N
Serial Number : ES3-A4 : Prototype : Pre-production : Production
Date of Manufacture : October 1999

3. Test Items and Procedure

: AC Power Line Conducted Emission Measurement
: Radiated Emission Measurement

Above all tests were performed under: ANSI C63.4 – 1992

: without deviation, : with deviation(details are found inside of this report)

4. Date of Test

Receipt of Test Sample : 18 October 1999
Test Completed on : 18 October 1999

Fumitoshi Nagaoka
Associate Director/ Ikoma Testing Laboratory

Table of Contents

0.	NVLAP ACCREDITATION AND MEASUREMENT UNCERTAINTY	3
0.1.	NVLAP Accreditation	3
0.2.	Measurement Uncertainty	3
1.	CERTIFICATION OF THE COMPLIANCE	3
2.	GENERAL INFORMATION	4
2.1.	Product Description	4
2.2.	Description for Equipment Authorization	5
2.3.	Test Facility.....	5
3.	TESTED SYSTEM	6
3.1.	Test Mode	6
3.2.	Operation of EUT System	6
3.3.	Characterization and condition of EUT System	6
3.4.	Block Diagram of EUT System.....	7
3.5.	List of EUT System.....	9
3.6.	List of Cables.....	10
4.	AC POWER LINE CONDUCTED EMISSION MEASUREMENT	12
4.1.	Test Procedure.....	12
4.2.	Test Results.....	13
4.3.	Photographs of EUT System Configuration	15
5.	RADIATED EMISSION MEASUREMENT	18
5.1.	Test Procedure.....	18
5.2.	Test Results	19
5.3.	Photographs of EUT System Configuration	23
6.	LIST OF TEST EQUIPMENTS	25

0. NVLAP ACCREDITATION AND MEASUREMENT UNCERTAINTY

0.1. NVLAP Accreditation

KEC is accredited by the National Voluntary Accreditation Program for the specific scope of accreditation under Lab Code: 200207-0.

When a test report concerns with the NVLAP Accreditation test, the first page of the test report is signed by NVLAP Approved Signatory together with the expression.

The report must not be used by the client to claim product endorsement by NVLAP or any agency of the U.S. Government.

0.2. Measurement Uncertainty

The result of a measurement is only an approximation or estimate of the value of a specific quantity. And thus the measurand is complete only when a statement of uncertainty is given.

KEC quotes Measurement Uncertainty (U) of +/- 4.9 dB for Radiated Emissions and of +/- 2.2 dB for Conducted Emissions.

1. CERTIFICATION OF THE COMPLIANCE

This test report is to certify that the tested device properly complies with the requirements of FCC Rules and Regulations Part 15 Subpart B Unintentional Radiators.

KEC evaluation criteria for compliance:

The Product complies, if

the measured results are below the specification limit by a margin more than or equal

$1/2 U$ (2.5 dB) for Radiated Emissions and

U (2.2 dB) for Conducted Emissions.

2. GENERAL INFORMATION

2.1. Product Description

The Model No. LF-D211 (referred to as the EUT in this report) is a DVD-RAM Drive. The EUT is built in the personal computer by using the ATAPI connector.

(1) Technical Specifications

Capacity	: 2.6 / 5.2 Gbyte (DVD-RAM) 4.7 / 9.4 Gbyte (DVD-RAM) 680 Mbyte (CD/CD-ROM)
CD support format	: CD-DA CD-ROM(Mode 1, 2) Kodak Photo CD
CD Rotational Speed	: × 24 (Maximum speed)

(2) Used Oscillating Frequencies

16.93 MHz	: IC Clock Generator, System Clock
27 MHz	: Optical disk control clock
33.86 MHz	: Optical disk control clock
4.3218 ~ 86.436 MHz	: Compact Disc Play Clock, Compact Disk play control clock
29.2 MHz	: DVD-RAM Write/Read Control Clock DVD-RAM Write Clock, DVD-RAM Read Clock
300 ± 50 MHz	: Override Laser High Frequency
66 MHz	: Digital Servo IC clock
13.5 MHz	: CPU clock

(3) Equipped Interface Terminals

ATAPI connector	: ATAPI Interface Connector, connected to personal computer
AUDIO OUT (ANALOG) connector	: Audio output connector (Analog)
DC Power connector	: Supply DC 5V and 12V from the personal computer
PHONE jack	: connected to the headphone
AUDIO OUT (Digital) Connector	: Audio output connector (Digital)

(4) Rated Power Supply

DC +5V and DC +12V	: supply from the personal computer
--------------------	-------------------------------------

2.2. Description for Equipment Authorization

(1) Category	:	<input type="checkbox"/> Class A	<input checked="" type="checkbox"/> Class B
(2) Reference Rule and Specification	:	FCC Rule Part 15	
		<input checked="" type="checkbox"/> Section 15.107 (a), 15.109 (a) and (c)	
		<input type="checkbox"/> Section 15.107 (b), 15.109 (b) and (c)	
(3) Type of device	:	<input checked="" type="checkbox"/> Personal Computer & Peripherals	
		<input type="checkbox"/> Other Digital Device	
(4) Kind of Equipment Authorization	:	<input type="checkbox"/> DoC	<input checked="" type="checkbox"/> Certification <input type="checkbox"/> Verification
(5) Procedure of Application	:	<input checked="" type="checkbox"/> Original Equipment	<input type="checkbox"/> Modification
(6) Highest Frequency used in the Device	:	300 ± 50 MHz	
(7) Upper Frequency of Radiated Emission Measurement Range	:	<input type="checkbox"/> 1000 MHz	<input checked="" type="checkbox"/> 2000 MHz <input type="checkbox"/> 5000 MHz

2.3. Test Facility

All tests described in this report were performed by:			
Name:	KANSAI ELECTRONIC INDUSTRY DEVELOPMENT CENTER (KEC) IKOMA TESTING LABORATORY		
Open Area Test Site	<input type="checkbox"/> No.1	<input type="checkbox"/> No.2	<input type="checkbox"/> No.3 <input checked="" type="checkbox"/> No.4
EMC M.C. Anechoic Chamber	<input type="checkbox"/> No.1		
Shielded Room	<input type="checkbox"/> No.2	<input checked="" type="checkbox"/> No.4	<input type="checkbox"/> EMC M.C. Shielded Room
Address:	12128, Takayama-cho Ikoma-city, Nara, 630-0101 Japan		
<p>These test facilities have been filed with the FCC under the criteria of ANSI C63.4-1992. The Open Area Test Site No.4, EMC MC. Anechoic Chamber No.1, Shielded Room No.4 and EMC MC. Shielded Room have been accredited by the NVLAP (Lab. Code: 200207-0) based on ISO/IEC Guide 25.</p> <p>Also the laboratory has been authorized by ITI (Interference Technology International, (UK), TUV Product Service (GER) and TUV Rheinland (GER) based on their criteria for testing laboratory (EN45001).</p>			

3. TESTED SYSTEM

3.1. Test Mode

The compliance tests were performed under the following two test modes.

- (1) DVD-RAM operation mode
- (2) CD-ROM operation mode

3.2. Operation of EUT System

(1) DVD-RAM operation mode

- 1) Insert the DVD-RAM Disk on the EUT
- 2) After a while, Key in as follows,
Cd fd8
Sdtide -C -E EMC47
- 3) Select the "****DVD****" and key in RETURN
Then, the test program was executed and following operation (a) to (f) were repeatedly.
 - (a) The data which was on the hard disk of the personal computer were written on the DVD-RAM Disk.
 - (b) The data which was on the DVD-RAM Disk were read.
 - (c) The data which was on the DVD-RAM Disk were copied to the hard disk on the personal computer.
 - (d) One-Line "H" patterns (79 characters) were appeared on the color display.
[(79 × 25) characters of "H" were appeared on the color display at full scale, and "H" pattern were scrolling repeatedly.]
 - (e) (a) to (d) operations were repeated at 15 times.
 - (f) "H" pattern were printed by the printer.

(2) CD-ROM operation mode

- 1) Insert the Compact Disc (Title: Nautilus, Model No.U77P030UA, Trade Name:Metatec) on the EUT.
- 2) After a while, Key in as follows,
Cd fd8
Sdtide -C -E EMC47
- 3) Select the "****CD****" and key in RETURN
Then, the test program was executed and following operation (a) to (e) were repeatedly.
 - (a) The data which was on the CD ROM were read at × 24 speed.
 - (b) The data which was on the CD ROM were copied to the hard disk on the personal computer.
 - (c) The EUT was set to playback the audio data on the CD at the standard speed, and its playback condition was observed by the stereo headphone and stereo radio cassette recorder by using the audio signal cable.
 - (d) One-Line "H" patterns (79 characters) were appeared on the color display.
[(79 × 25) characters of "H" were appeared on the color display at full scale, and "H" pattern were scrolling repeatedly.]
 - (e) "H" pattern were printed by the printer.

[Note]

- (1) Test program is prepared by the applicant.
- (2) OS : MD-DOS

3.3. Characterization and condition of EUT System

: normal, : not normal(that is)

3.4. Block Diagram of EUT System

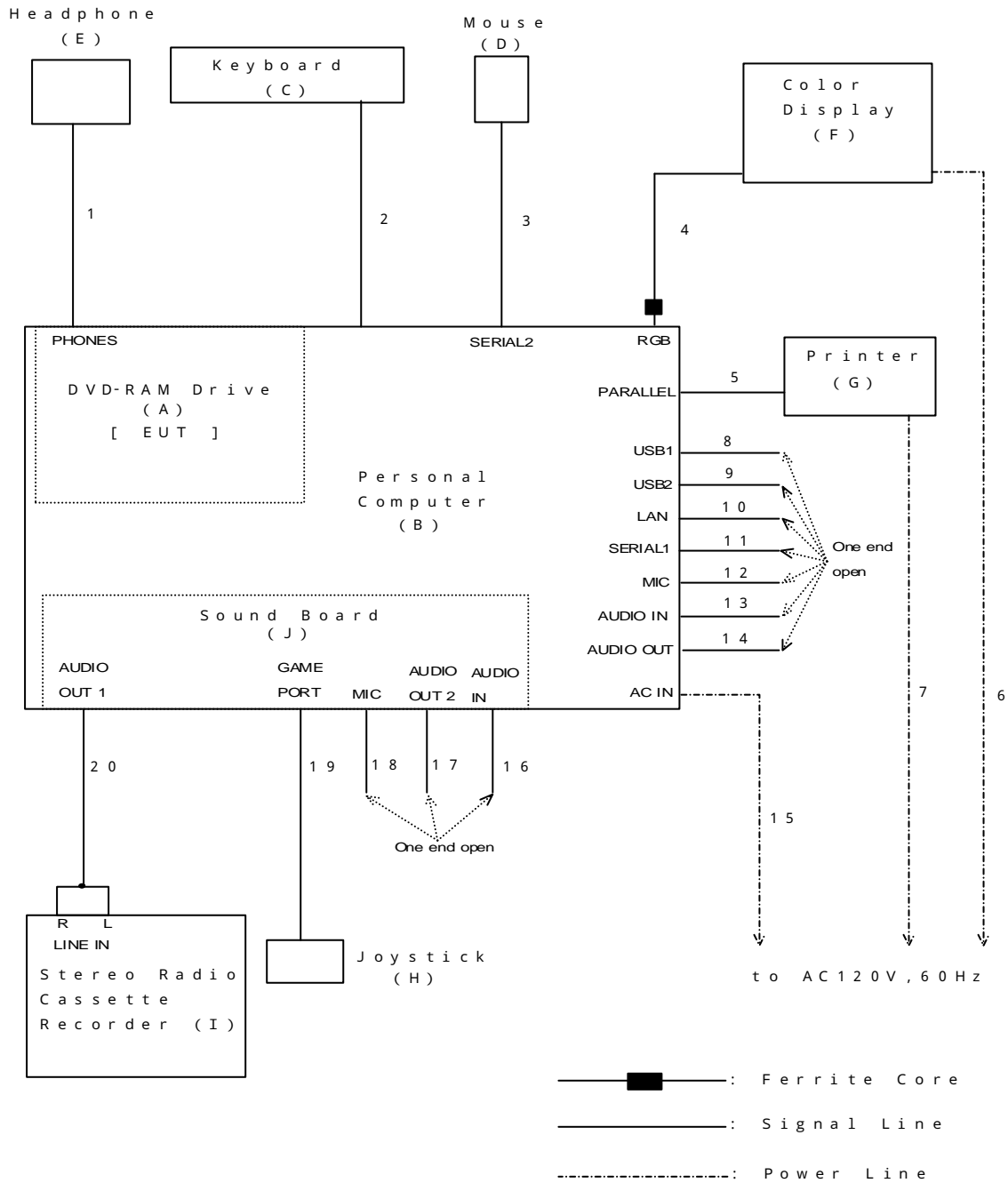

[Note]

- (1) The EUT was installed on the drive slot of personal computer (B).
- (2) Sound Board was installed on the expansion slot 3 of personal computer (B).
- (3) The connection of personal computer (B) inside, see next page.
- (4) See 3.5 List of EUT System and 3.6 List of Cables

-Continued-

Inside of personal computer (B)

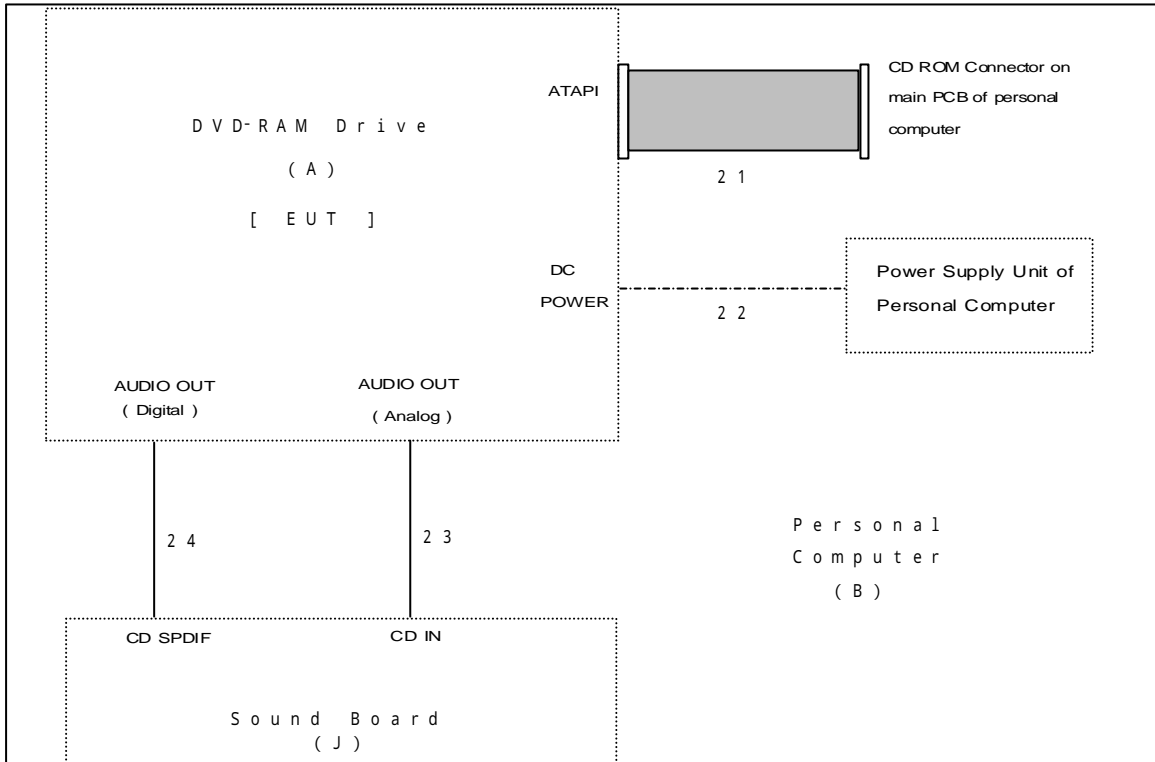

————— : S i g n a l L i n e

- - - - - : P o w e r L i n e

[Note]

See 3.5 List of EUT System and 3.6 List of Cables.

3.5. List of EUT System

No	Device Name (Interface)	Model Number (Serial Number)	FCC ID (Trade Name)	Note	Remark
A	DVD-RAM Drive (ATAPI)	LF-D211 (ES3-A4)	ACJODSDLFD211 (-)	Pre-production	(1)
B	Personal Computer	DCM (SQBDY)	N/A (DELL)	FCC ID:DoC	
C	Keyboard	SK-1000REW (M971226124)	GYUR36SK (DELL)		(2)
D	Mouse (Serial)	Model 606 (0044104)	HQA2VTEAM2 (Firenze)		
E	Headphone	SE-M650 (-)	N/A (Pioneer)		
F	Color Display (Video)	D2804B (KR52737221)	CSYSC-428VSP (HEWLETT PACKARD)		
G	Printer (Parallel)	P112A (BCX1032696)	BKMFBP112A (EPSON)		
H	Joystick	JY-DV16 (98004270)	- (SANWA SUPPLY)		
I	Stereo Radio Cassette Recorder	RX-FW50 (6EANC39715)	N/A (National)		
J	Sound Board	CT4670 (T4670910036125)	N/A (Greative Labs)	FCC ID:DoC	

N/A: Not Applicable

[Remark]

(1): EUT

(2): Accessory of personal computer (B)

3.6. List of Cables

No	Cable Name	Shielded (Y/N)	Length (m)	Note	Remark
1	Headphone (E) Cable	N	1.1	Stereo mini plug type	(1)
2	Keyboard (C) Cable	Y	1.9		(1)
3	Mouse (D) Cable	Y	1.7	D-sub 9pin type	(1)
4	VGA Cable	Y	1.4	with one ferrite core, permanently attached to Color Display (F)	
5	Parallel Interface Cable	Y	1.8		
6	AC Power Cord of Color Display (F)	N	2.2	3-wires type	(2)
7	AC Power Cord of Printer (G)	N	1.9	3-wires type	(1)
8	USB Cable	Y	1.0	One end open	
9	USB Cable	Y	1.0	One end open	
10	LAN Cable	Y	1.0	One end open	
11	Serial Interface Cable	Y	1.0	One end open, D-sub 9pin to D-sub 25pin type	
12	Audio Cable	Y	1.5	One end open, Both side stereo mini plug type	
13	Audio Cable	Y	1.5	One end open, Both side stereo mini plug type	

- Continued -

No	Cable Name	Shielded (Y/N)	Length (m)	Note	Remark
14	Audio Cable	Y	1.5	One end open, Both side stereo mini plug type	
15	AC Power Cord of Personal Computer (B)	N	1.9	3-wires type	(2)
16	Audio Cable	Y	1.5	One end open, Both side stereo mini plug type	
17	Audio Cable	Y	1.5	One end open, Both side stereo mini plug type	
18	Audio Cable	Y	1.5	One end open, Both side stereo mini plug type	
19	Joystick (H) Cable	Y	1.7		(1)
20	Audio Signal Cable	Y	1.5	Stereo mini plug to RCA type	
21	IDE Cable	N	0.44	40-wires flat type	
22	DC Power Cable	N	0.37	Accessory of personal computer (B), 4-wires type	
23	Analog Audio Cable	Y	0.66	2-wires type	(3)
24	Digital Audio Cable	Y	0.67	3-wires type	(3)

[Remark]

- (1): Permanently attached to each peripheral device
- (2): Accessory cable of each peripheral device
- (3): Accessory cable of Sound Board (J)

4. AC POWER LINE CONDUCTED EMISSION MEASUREMENT

4.1. Test Procedure

<p>(1) Configure the EUT System in accordance with ANSI C63.4-1992 section 7. <input checked="" type="checkbox"/>: without deviation, <input type="checkbox"/>: with deviation(details are found below) See also the block diagram and the photographs of EUT System configuration in this report.</p> <p>(2) Connect the EUT's AC power cord to one Line Impedance Stabilization Network (LISN).</p> <p>(3) Any other power cord of other equipment is connected to a LISN different from the LISN used for the EUT.</p> <p>(4) Warm up the EUT System.</p> <p>(5) Activate the EUT System and run the software prepared for the test, if necessary.</p> <p>(6) Connect the spectrum analyzer (*1) to the measuring port of the LISN for the EUT, using a calibrated coaxial cable.</p> <p>(7) To find out an EUT System condition, which produces the maximum emission, the configuration of EUT System, the position of the cables, and the operation mode, are changed under normal usage of the EUT.</p> <p>(8) The spectrums are scanned from 450 kHz to 30 MHz and collect the six highest emissions minimum on the spectrum analyzer relative to the limits in the whole range.</p> <p>(9) The test receiver (*2) is connected to the LISN for the EUT, and the six highest emissions minimum recorded above are measured.</p>	<p>[Note]</p> <p>(*1) Spectrum Analyzer Set Up Conditions Frequency range : 450 kHz - 30 MHz Resolution bandwidth : 10 kHz Video bandwidth : 1 MHz Detector function : Peak mode</p> <p>(*2) Test Receiver Set Up Conditions Detector function : Quasi-Peak/ Average (if necessary) IF bandwidth : 10 kHz</p>
-----------------------------------------------------------------------------------------------------------------------------------------------------------------------------------------------------------------------------------------------------------------------------------------------------------------------------------------------------------------------------------------------------------------------------------------------------------------------------------------------------------------------------------------------------------------------------------------------------------------------------------------------------------------------------------------------------------------------------------------------------------------------------------------------------------------------------------------------------------------------------------------------------------------------------------------------------------------------------------------------------------------------------------------------------------------------------------------------------------------------------------------------------------------------------------------------------------------------------------------------------------------------------------------------------------------------------------------------------------------	--------------------------------------------------------------------------------------------------------------------------------------------------------------------------------------------------------------------------------------------------------------------------------------------------------------------------------------------------------------------------------------------------------------------------------------------------------------

4.2. Test Results

(1) DVD-RAM operation mode

Measured Frequency (MHz)	LISN Factor (dB)	Meter Reading		Maximum RF Voltage (dBuV)	Limits (dBuV)	Margin for Limits (dB)
		Va (dBuV)	Vb (dBuV)			
0.623	0.3	43.1	43.4	43.7	48.0	4.3
0.935	0.3	39.2	38.4	39.5	48.0	8.5
1.247	0.3	35.8	35.4	36.1	48.0	11.9
6.236	0.4	41.3	41.8	42.2	48.0	5.8
6.339	0.4	40.8	41.3	41.7	48.0	6.3
6.548	0.4	41.4	42.7	43.1	48.0	4.9

(2) CD-ROM operation mode

Measured Frequency (MHz)	LISN Factor (dB)	Meter Reading		Maximum RF Voltage (dBuV)	Limits (dBuV)	Margin for Limits (dB)
		Va (dBuV)	Vb (dBuV)			
0.623	0.3	43.4	43.6	43.9	48.0	4.1
0.934	0.3	38.8	38.1	39.1	48.0	8.9
1.038	0.3	35.2	34.8	35.5	48.0	12.5
6.230	0.4	40.1	40.6	41.0	48.0	7.0
6.334	0.4	40.5	41.2	41.6	48.0	6.4
6.541	0.4	39.6	41.5	41.9	48.0	6.1

[Calculation method] Maximum RF Voltage (dBuV) = Meter Reading (at maximum level of Va, Vb) + LISN Factor (dB)
[Note] LISN Correction Factor includes the cable loss.
[Attention] The EUT is designed to use as built in a personal computer. Therefore, the conducted measurement of the EUT, is tested under the AC power lines of the personal computer.

[Environment]

Temperature: 21

Humidity: 64%

[Tested Date/ Tester]

19 October 1999

Signature

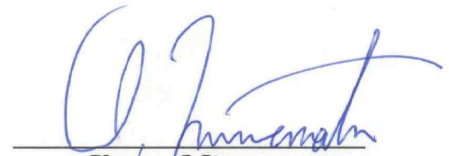

Ikuya Minematsu

Test Results in Graph

(1) DVD-RAM operation mode

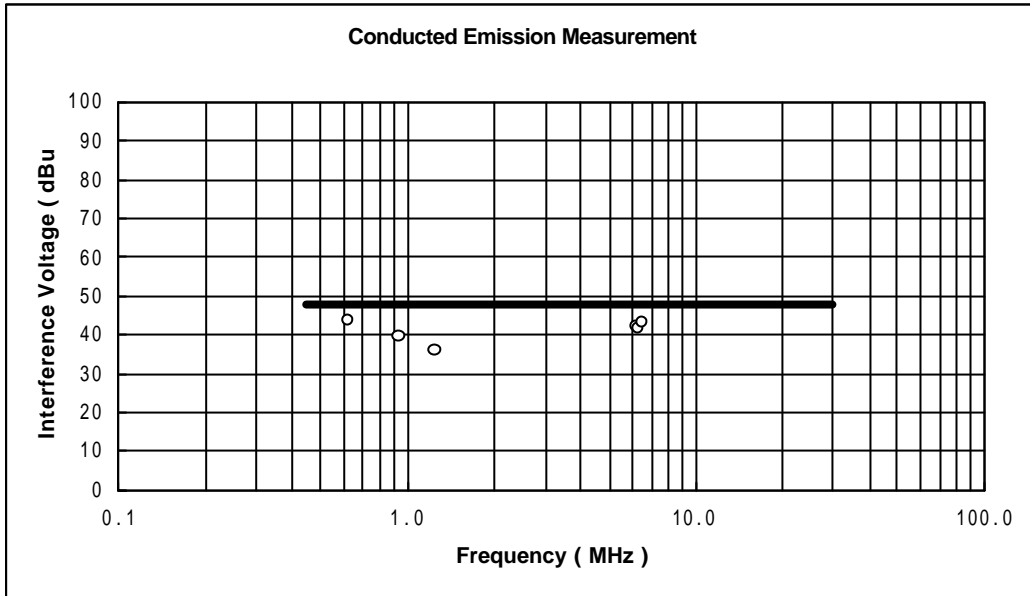

(2) CD-ROM operation mode

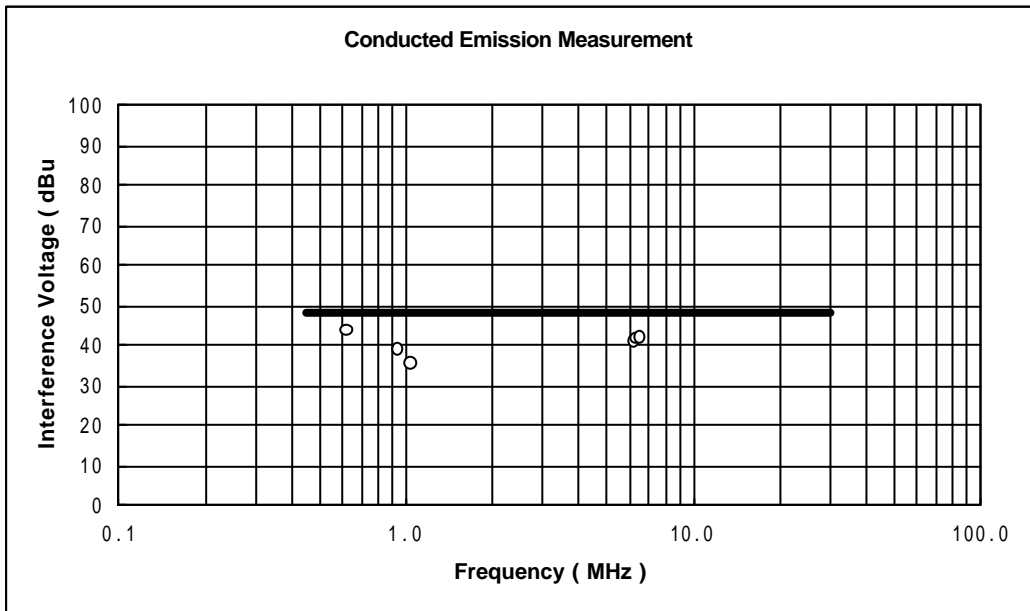

[Note]

- : Maximum RF Voltage
- : Limit Line

4.3. Photographs of EUT System Configuration

Maximum operation mode

FRONT VIEW



- Continued -

Maximum operation mode

LEFT SIDE VIEW

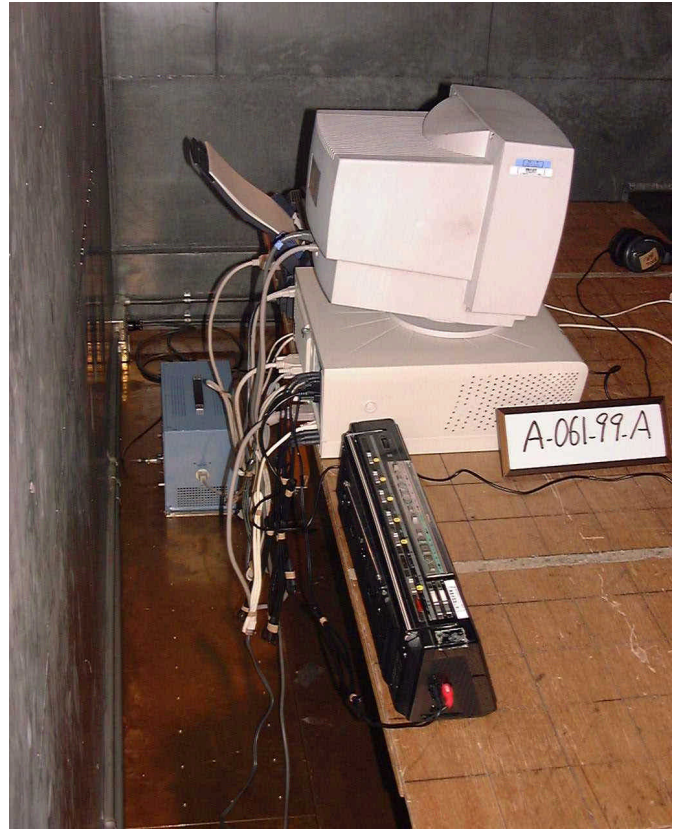

- Continued -

Maximum operation mode

RIGHT SIDE VIEW



5. RADIATED EMISSION MEASUREMENT

5.1. Test Procedure

<p>(1) Configure the EUT System in accordance with ANSI C63.4-1992 section 8. <input checked="" type="checkbox"/>: without deviation, <input type="checkbox"/>: with deviation(details are found below) See also the block diagram and the photographs of EUT System configuration in this report.</p> <p>(2) If the EUT system is connected to a public power network, all power cords for the EUT System are connected the receptacle on the turntable.</p> <p>(3) Warm up the EUT System.</p> <p>(4) Activate the EUT System and run the prepared software for the test, if necessary.</p> <p>(5) To find out the emissions of the EUT System, preliminary radiated measurement are performed at a closer distance than that specified for final radiated measurement using the spectrum analyzer (*1) and the broad band antenna. In the frequency above 1 GHz, it is performed using the spectrum analyzer (*2) and the horn antenna.</p> <p>(6) To find out an EUT System condition, which produces the maximum emission, the configuration of EUT System, the position of the cables, and the operation mode, are changed under normal usage of the EUT.</p> <p>(7) The spectrums are scanned from 30 MHz to the upper frequency of measurement range, and collect the six highest emissions minimum on the spectrum analyzer relative to the limits in the whole range.</p> <p>(8) In final compliance test, the six highest emissions minimum, recorded above, are measured at the specified distance using the broad band antenna or the tuned dipole antenna and the test receiver (*3). In the frequency above 1 GHz, the measurements are performed by the horn antenna and <input checked="" type="checkbox"/> the test receiver (*4). <input type="checkbox"/> the spectrum analyzer(*2).</p>	<p>[Note]</p> <p>(*1) Spectrum Analyzer Set Up Conditions Frequency range : 30 - 1000 MHz Resolution bandwidth : 100 kHz Detector function : Peak mode</p> <p>(*2) Spectrum Analyzer Set Up Conditions Frequency range : 1 GHz - Upper frequency of measurement range Resolution bandwidth : 1 MHz Video bandwidth : 1 MHz Attenuator : 10 dB Detector function : Peak mode</p> <p>(*3) Test Receiver Set Up Conditions Detector function : Quasi-Peak IF bandwidth : 120 kHz</p> <p>(*4) Test Receiver Set Up Conditions Detector function : Average IF bandwidth : 1 MHz</p>
--------------------------------------------------------------------------------------------------------------------------------------------------------------------------------------------------------------------------------------------------------------------------------------------------------------------------------------------------------------------------------------------------------------------------------------------------------------------------------------------------------------------------------------------------------------------------------------------------------------------------------------------------------------------------------------------------------------------------------------------------------------------------------------------------------------------------------------------------------------------------------------------------------------------------------------------------------------------------------------------------------------------------------------------------------------------------------------------------------------------------------------------------------------------------------------------------------------------------------------------------------------------------------------------------------------------------------------------------------------------------------------------------------------------------------------------------------------------------------------------------------------------------------------------------------------------------------------------------------------------------------------------------------------------------------------------------------------------------------------------------------------------------------------------------------------------------------------------------------------------	--------------------------------------------------------------------------------------------------------------------------------------------------------------------------------------------------------------------------------------------------------------------------------------------------------------------------------------------------------------------------------------------------------------------------------------------------------------------------------------------------------------------------------------------------------------------------------------------------------------------------------------------------------------------------------------------------------------------------------------------

5.2. Test Results

(1) DVD-RAM operation mode

Measurement Distance : 3m : 10m

Measured Frequency	Antenna Factor	Meter Reading		Maximum Field Strength	Limits	Margin for Limits
		Horizontal	Vertical			
(MHz)	(dB)	(dBuV)	(dBuV)	(dBuV/m)	(dBuV/m)	(dB)
35.35	16.6	6.0	13.4	30.0	40.0	10.0
36.47	16.1	5.4	14.4	30.5	40.0	9.5
106.89	12.9	8.1	13.2	26.1	43.5	17.4
159.76	17.1	12.4	10.1	29.5	43.5	14.0
196.61	18.7	16.5	12.6	35.2	43.5	8.3
239.97	19.7	14.4	7.6	34.1	46.0	11.9
* 314.48	21.6	21.0	11.6	42.6	46.0	3.4
368.66	18.4	17.5	14.0	35.9	46.0	10.1
425.01	19.7	15.3	9.7	35.0	46.0	11.0
576.90	23.3	10.8	9.0	34.1	46.0	11.9
720.18	25.5	7.4	4.5	32.9	46.0	13.1
943.66	28.0	10.1	9.0	38.1	46.0	7.9
1032.35	-11.8	42.8	44.3	32.5	54.0	21.5
1265.54	-12.9	40.0	40.4	27.5	54.0	26.5
1465.56	-13.3	34.1	39.0	25.7	54.0	28.3

[Note]

- (1) Antenna Factor includes the cable loss.
 (2) * mark in Measured Frequency : Measured with the tuned dipole antenna.
 no mark in Measured Frequency : Measured with the broadband antenna.
 (3) Above 1000 MHz, the antenna factor is includes both of a cable loss and pre-amplifier gain.

[Calculation method]

Maximum Field Strength (dBuV/m)
 = Meter Reading (at maximum level of Horizontal or Vertical) (dBuV) + Antenna Factor (dB)

[Environment]

Temperature: 17

Humidity: 75%

[Tested Date/ Tester]

18 October 1999

Signature

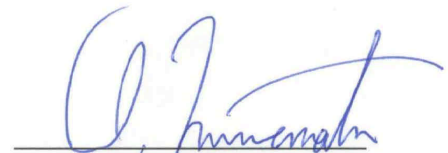

Ikuya Minematsu

Test Results in Graph

(1) DVD-RAM operation mode

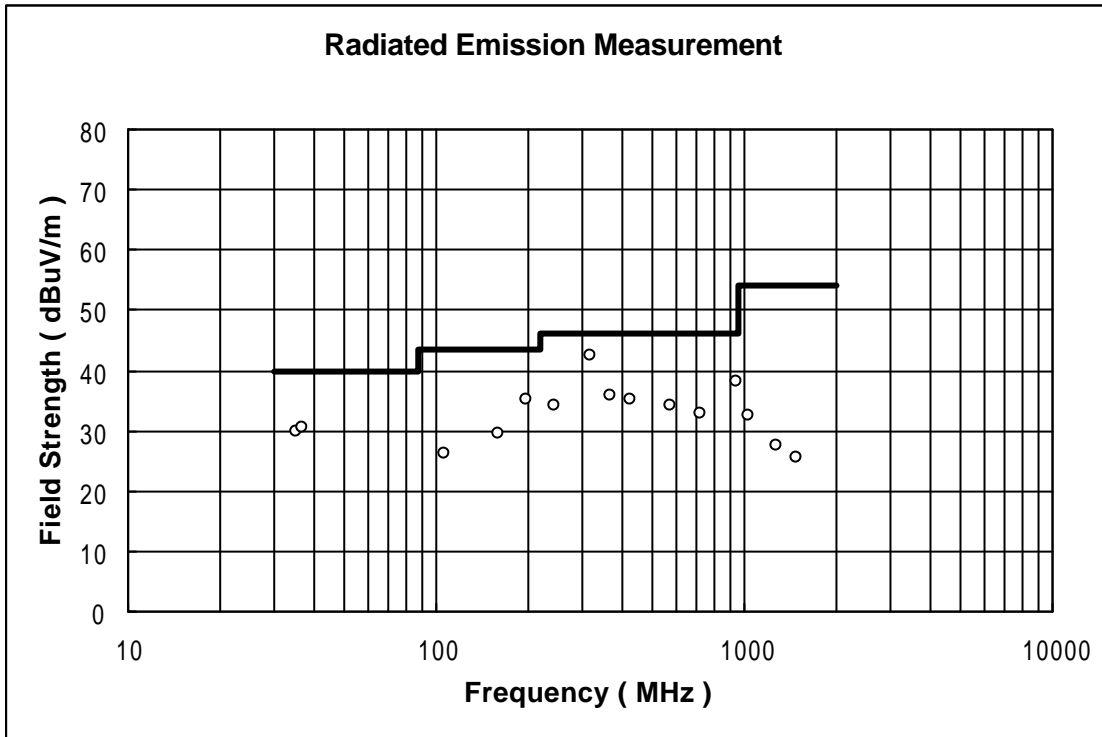

[Note]

- : Maximum Field Strength
- : Limit Line

(2)CD-ROM operation mode

Measurement Distance : 3m : 10m

Measured Frequency	Antenna Factor	Meter Reading		Maximum Field Strength	Limits	Margin for Limits
		Horizontal	Vertical			
(MHz)	(dB)	(dBuV)	(dBuV)	(dBuV/m)	(dBuV/m)	(dB)
35.35	16.6	4.6	13.6	30.2	40.0	9.8
36.47	16.1	2.0	13.1	29.2	40.0	10.8
159.72	17.1	13.5	9.5	30.6	43.5	12.9
196.61	18.7	16.4	12.6	35.1	43.5	8.4
199.42	18.8	10.0	7.7	28.8	43.5	14.7
239.97	19.7	13.6	7.3	33.3	46.0	12.7
368.63	18.4	15.0	11.7	33.4	46.0	12.6
380.93	18.7	16.4	10.0	35.1	46.0	10.9
542.96	22.5	6.2	14.0	36.5	46.0	9.5
576.88	23.3	7.8	13.8	37.1	46.0	8.9
742.05	25.9	4.1	7.6	33.5	46.0	12.5
911.99	28.1	3.4	4.8	32.9	46.0	13.1
1032.40	-11.8	39.4	42.5	30.7	54.0	23.3
1250.88	-12.7	37.3	37.5	24.8	54.0	29.2

[Note]

- (1) Antenna Factor includes the cable loss.
- (2) * mark in Measured Frequency : Measured with the tuned dipole antenna.
no mark in Measured Frequency : Measured with the broadband antenna.
- (3) Above 1000 MHz, the antenna factor is includes both of a cable loss and pre-amplifier gain.

[Calculation method]

Maximum Field Strength (dBuV/m)
= Meter Reading (at maximum level of Horizontal or Vertical) (dBuV) + Antenna Factor (dB)

[Environment]

Temperature: 17

Humidity: 75%

[Tested Date/ Tester]

18 October 1999

Signature

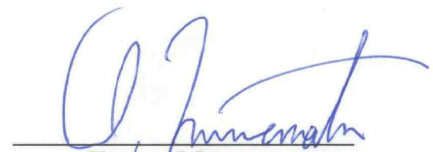

Ikuya Minematsu

Test Results in Graph

(2) CD-ROM operation mode

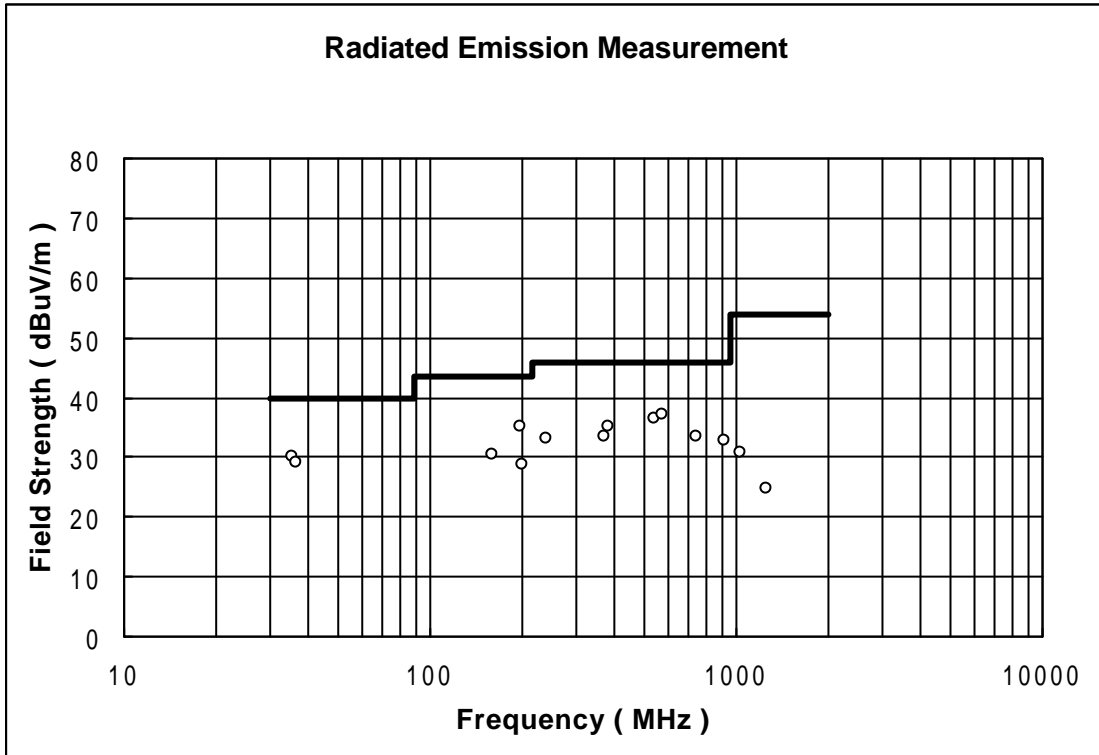

[Note]

- : Maximum Field Strength
- : Limit Line

5.3. Photographs of EUT System Configuration

Maximum operation mode

FRONT VIEW



- Continued -

Maximum operation mode

REAR VIEW



6. LIST OF TEST EQUIPMENTS

Equipment	Manufacturer	Model No.	Specifications	KEC Control No.	Test Item (*)	Last Cal.	Next Cal.
Test Receiver	Rohde & Schwarz	ESHS10	Frequency Range 9 kHz – 30 MHz	FS-48-2	1	1999/9	2000/6
		ESVS10	Frequency Range 20 MHz – 1 GHz	FS-82	2	1999/2	2000/2
		ESVD	Frequency Range 20 MHz – 2.05 GHz	FS-79	3	1999/4	2000/4
Spectrum Analyzer	Advantest	R3261C	Frequency Range 9 kHz – 2.6 GHz	SA-41	2,3	1999/8	2000/8
Spectrum Analyzer	Hewlett Packard	8568B	Frequency Range 100 Hz – 1.5 GHz	FS-46-3	1	1999/6	2000/6
Pre-Amprifier	Hewlett Packard	8449B	Frequency Range 1GHz - 26.5GHz	AM-52	3	1999/4	2000/4
Biconical Antenna	Schwarzbeck	BBA9106	Frequency Range 30 MHz – 300 MHz	AN-94	2	1999/2	2000/2
Log-Periodic Antenna	Schwarzbeck	UHALP9108A	Frequency Range 300 MHz – 1 GHz	AN-217	2	1999/2	2000/2
Tuned Dipole Antenna	Kyoritsu	KBA-511AS	Frequency Range 25 MHz – 500 MHz	AN-135	2	1999/3	2000/3
		KBA-611S	Frequency Range 500 MHz – 1 GHz	AN-137	N/A	1999/3	2000/3
Horn Antenna	Raven	91888-1	Frequency Range 1GHz- - 2GHz	AN-167	3	1997/11	1999/11
LISN for EUT	Kyoritsu	KNW-407	Frequency Range 150 kHz – 30 MHz Capacity AC 250V, 15A	FL-107	1	1999/4	2000/4
LISN for Peripherals	Kyoritsu	KNW-242	Frequency Range 10 kHz – 30 MHz Capacity AC 250V, 15A	FL-110	1	1999/4	2000/4

[Note]

Test Item (*):

- 1: Conducted Emission Measurement
- 2: Radiated Emission Measurement (30 MHz – 1 GHz)
- 3: Radiated Emission Measurement (1 GHz <)

N/A: Not Applicable

The overall program of calibration and verification of equipment is designed and operated so as to ensure that measurements made by KEC are traceable to national standards of measurement or equivalent abroad.