

HEARING AID COMPATIBILITY

Applicant Name:
 Panasonic Corporation of North America
 One Panasonic Way, 4B-8
 Secaucus, NJ 07094
 United States

Date of Testing:
 05/08/2018
Test Site/Location:
 PCTEST Lab, Columbia, MD, USA
Test Report Serial No.:
 1M1804230079-10.ACJ

FCC ID:	ACJFZN1D
APPLICANT:	PANASONIC CORPORATION OF NORTH AMERICA

Scope of Test: RF Emissions Testing
Application Type: Certification
FCC Rule Part(s): CFR §20.19(b)
HAC Standard: ANSI C63.19-2011
 285076 D01 HAC Guidance v05
 285076 D02 T-Coil testing for CMRS IP v03
DUT Type: Portable Handset
Model: FZ-N1EB, FZ-N1EC
Test Device Serial No.: Pre-Production Sample [S/N: 03490]

C63.19-2011 HAC Category:	M4 (RF EMISSIONS CATEGORY)
----------------------------------	-----------------------------------

This wireless portable device has been shown to be hearing-aid compatible under the above rated category, specified in ANSI/IEEE Std. C63.19-2011 and has been tested in accordance with the specified measurement procedures. Hearing-Aid Compatibility is based on the assumption that all production units will be designed electrically identical to the device tested in this report. Test results reported herein relate only to the item(s) tested. North America bands only.

I attest to the accuracy of data. All measurements reported herein were performed by me or were made under my supervision and are correct to the best of my knowledge and belief. I assume full responsibility for the completeness of these measurements and vouch for the qualifications of all persons taking them.

 Randy Ortanez
 President







FCC ID: ACJFZN1D	 HAC (RF EMISSIONS) TEST REPORT		Approved by: Quality Manager
Filename: 1M1804230079-10.ACJ	Test Dates: 05/08/2018	DUT Type: Portable Handset	Page 1 of 35

TABLE OF CONTENTS

1.	INTRODUCTION	3
2.	DUT DESCRIPTION.....	4
3.	ANSI/IEEE C63.19 PERFORMANCE CATEGORIES	6
4.	SYSTEM SPECIFICATIONS.....	7
5.	MODULATION INTERFERENCE FACTOR.....	12
6.	RF CONDUCTED POWER MEASUREMENTS.....	17
7.	JUSTIFICATION OF HELD TO EAR MODES TESTED	30
8.	EQUIPMENT LIST.....	31
9.	MEASUREMENT UNCERTAINTY	32
10.	CONCLUSION.....	33
11.	REFERENCES	34

FCC ID: ACJFZN1D	 PCTEST <small>ENGINEERING LABORATORY, INC.</small>	HAC (RF EMISSIONS) TEST REPORT		Approved by: Quality Manager
Filename: 1M1804230079-10.ACJ	Test Dates: 05/08/2018	DUT Type: Portable Handset		Page 2 of 35

1. INTRODUCTION

On July 10, 2003, the Federal Communications Commission (FCC) adopted new rules requiring wireless manufacturers and service providers to provide digital wireless phones that are compatible with hearing aids. The FCC has modified the exemption for wireless phones under the Hearing Aid Compatibility Act of 1998 (HAC Act) in WT Docket 01-309 RM-8658¹ to extend the benefits of wireless telecommunications to individuals with hearing disabilities. These benefits encompass business, social and emergency communications, which increase the value of the wireless network for everyone. An estimated more than 10% of the population in the United States show signs of hearing impairment and of that fraction, almost 80% use hearing aids. Approximately 500 million people worldwide suffer from hearing loss.

Compatibility Tests Involved:

The standard calls for wireless communications devices to be measured for:

- RF Electric-field emissions
- T-coil mode, magnetic-signal strength in the audio band
- T-coil mode, magnetic-signal frequency response through the audio band
- T-coil mode, magnetic-signal and noise articulation index

The hearing aid must be measured for:

- RF immunity in microphone mode
- RF immunity in T-coil mode

In the following tests and results, this report includes the evaluation for a wireless communications device.

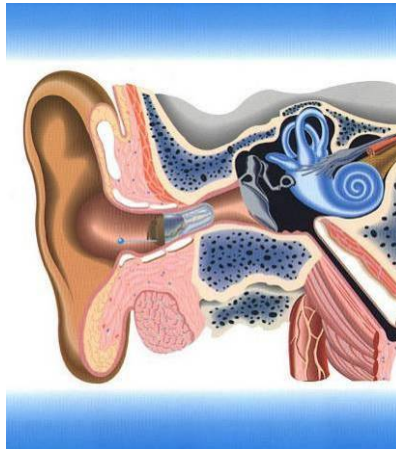



Figure 1-1 Hearing Aid *in-vitu*

¹ FCC Rule & Order, WT Docket 01-309 RM-8658

FCC ID: ACJFZN1D	 PCTEST ENGINEERING LABORATORY, INC.	HAC (RF EMISSIONS) TEST REPORT	 Panasonic	Approved by: Quality Manager
Filename: 1M1804230079-10.ACJ	Test Dates: 05/08/2018	DUT Type: Portable Handset	Page 3 of 35	

2. DUT DESCRIPTION



FCC ID: ACJFZN1D
 Manufacturer: Panasonic Corporation of North America
 One Panasonic Way, 4B-8
 Secaucus, NJ 07094
 United States
 Model: FZ-N1EB, FZ-N1EC
 Serial Number: 03490
 Antenna Configurations: Internal Antenna
 DUT Type: Portable Handset

I. LTE Band Selection

This device supports the following pair of LTE bands with similar frequencies: LTE B66 & B4. This pair of LTE bands has the same target power and shares the same transmission path. Since the supported frequency span for the smaller LTE band is completely covered by the larger LTE band, only the larger LTE band (LTE B66) was evaluated for hearing-aid compliance.



**Table 2-1
FZ-N1EB HAC Air Interfaces**

Air-Interface	Band (MHz)	Type Transport	HAC Tested	Simultaneous But Not Tested	Name of Voice Service
UMTS	850	VD	No ¹	Yes: WIFI or BT	CMRS Voice
	1900				
	HSPA	VD	No ¹	Yes: WIFI or BT	Google Duo
LTE (FDD)	700 (B12)	VD	No ¹	Yes: WIFI or BT	VoLTE, Google Duo
	780 (B13)				
	790 (B14)				
	850 (B5)				
	1700 (B4)				
	1700 (B66)				
WIFI	2450	VD	No ¹	Yes: UMTS or LTE	Google Duo
	5200 (U-NII 1)				
	5300 (U-NII 2A)				
	5500 (U-NII 2C)				
	5800 (U-NII 3)				
BT	2450	DT	No	Yes: UMTS or LTE	N/A
Type Transport VO = Voice Only DT = Digital Data - Not intended for CMRS Service VD = CMRS and IP Voice over Data Transport			Notes: 1. Evaluated for MIF and low-power exemption.		

FCC ID: ACJFZN1D	PCTEST ENGINEERING LABORATORY, INC.	HAC (RF EMISSIONS) TEST REPORT		Approved by: Quality Manager
Filename: 1M1804230079-10.ACJ	Test Dates: 05/08/2018	DUT Type: Portable Handset	Page 4 of 35	

Table 2-2
FZ-N1EC HAC Air Interfaces

Air-Interface	Band (MHz)	Type Transport	HAC Tested	Simultaneous But Not Tested	Name of Voice Service
WIFI	2450	DT	No ¹	N/A	Google Duo
	5200 (U-NII 1)				
	5300 (U-NII 2A)				
	5500 (U-NII 2C)				
	5800 (U-NII 3)				
BT	2450	DT	No	N/A	N/A
Type Transport VO = Voice Only DT = Digital Data - Not intended for CMRS Service VD = CMRS and IP Voice over Data Transport			Notes: 1. Evaluated for MIF and low-power exemption.		



FCC ID: ACJFZN1D	 PCTEST ENGINEERING LABORATORY, INC.	HAC (RF EMISSIONS) TEST REPORT		Approved by: Quality Manager	
Filename: 1M1804230079-10.ACJ	Test Dates: 05/08/2018	DUT Type: Portable Handset	Page 5 of 35		

3. ANSI/IEEE C63.19 PERFORMANCE CATEGORIES

I. RF EMISSIONS

The ANSI Standard presents performance requirements for acceptable interoperability of hearing aids with wireless communications devices. When these parameters are met, a hearing aid operates acceptably in close proximity to a wireless communications device.

Category	Telephone RF Parameters
Near field Category	E-field emissions CW dB(V/m)
f < 960 MHz	
M1	50 to 55
M2	45 to 50
M3	40 to 45
M4	< 40
f > 960 MHz	
M1	40 to 45
M2	35 to 40
M3	30 to 35
M4	< 30
Table 3-1 WD near-field categories as defined in ANSI C63.19-2011	

FCC ID: ACJFZN1D	 PCTEST ENGINEERING LABORATORY, INC.	HAC (RF EMISSIONS) TEST REPORT	 Panasonic	Approved by: Quality Manager
Filename: 1M1804230079-10.ACJ	Test Dates: 05/08/2018	DUT Type: Portable Handset	Page 6 of 35	

4. SYSTEM SPECIFICATIONS

ER3DV6 E-Field Probe Description

Construction:	One dipole parallel, two dipoles normal to probe axis Built-in shielding against static charges
Calibration:	In air from 100 MHz to 3.0 GHz (absolute accuracy $\pm 6.0\%$, $k=2$)
Frequency:	100 MHz to > 6 GHz; Linearity: ± 0.2 dB (100 MHz to 3 GHz)
Directivity	± 0.2 dB in air (rotation around probe axis) ± 0.4 dB in air (rotation normal to probe axis)
Dynamic Range	2 V/m to > 1000 V/m (M3 or better device readings fall well below diode compression point)
Linearity:	± 0.2 dB
Dimensions	Overall length: 330 mm (Tip: 16 mm) Tip diameter: 8 mm (Body: 12 mm) Distance from probe tip to dipole centers: 2.5 mm

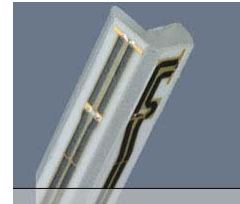
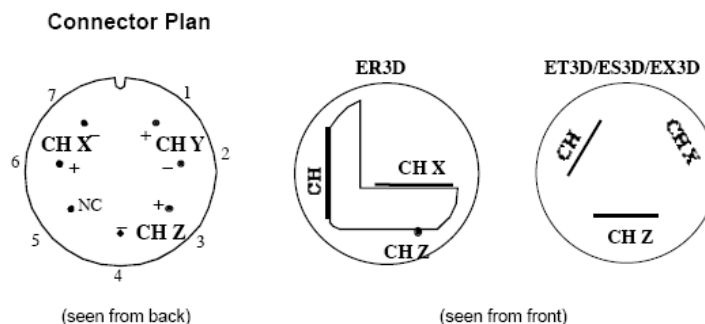

Figure 4-1
E-field Free-space Probe

Probe Tip Description

HAC field measurements take place in the close near field with high gradients. Increasing the measuring distance from the source will generally decrease the measured field values (in case of the validation dipole approx. 10% per mm).

The electric field probes have an irregular internal geometry because it is physically not possible to have the 3 orthogonal sensors situated with the same center. The effect of the different sensor centers is accounted for in the HAC uncertainty budget ("sensor displacement"). Their geometric center is at 2.5mm from the tip, and the element ends are 1.1mm closer to the tip.



The antistatic shielding inside the probe is connected to the probe connector case.

FCC ID: ACJFZN1D	PCTEST ENGINEERING LABORATORY, INC.	HAC (RF EMISSIONS) TEST REPORT	Approved by: Quality Manager
Filename: 1M1804230079-10.ACJ	Test Dates: 05/08/2018	DUT Type: Portable Handset	Page 7 of 35

Instrumentation Chain

Equation 1

Conversion of Connector Voltage u_i to E-Field E_i

$$E_i = \sqrt{\frac{u_i + (u_i^2 \cdot CF)/(DCP)}{Norm_i \cdot ConvF}}$$

whereby

E_i : electric field in V/m
 u_i : voltage of channel i at the connector in μV
 $Norm_i$: sensitivity of channel i in $\mu\text{V}/(\text{V/m})^2$
 $ConvF$: enhancement factor in liquid ($ConvF=1$ for Air)
 DCP : diode compression point in μV
 CF : signal crest factor (peak power/average power)

Conditions of Calibration

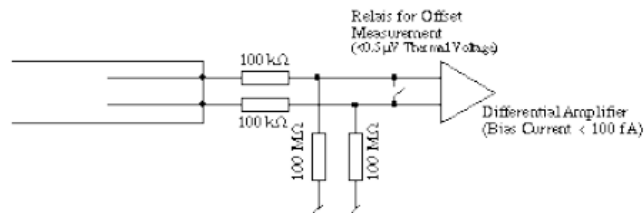

Please note:

- a lower input impedance of the amplifier will result in different sensitivity factors $Norm_i$ and DCP
- larger bias currents will cause higher offset

Probe Response to Frequency

The E-field sensors have inherently a very flat frequency response. They are calibrated with a number of frequencies resulting in a common calibration factor, with the frequency behavior documented in the calibration certificate (See also below).

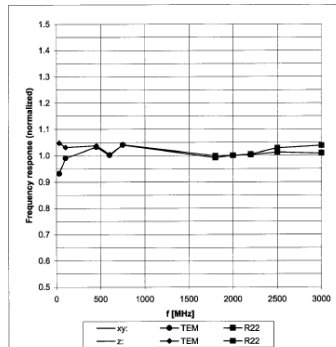

Frequency Response of E-Field

(TEM-Cell:if110 EXX, Waveguide R22)



Uncertainty of Frequency Response of E-field: $\pm 6.3\%$ ($k=2$)

Figure 4-2 E-Field Probe Frequency Response

FCC ID: ACJFZN1D	 PCTEST ENGINEERING LABORATORY, INC.	HAC (RF EMISSIONS) TEST REPORT	 Panasonic	Approved by: Quality Manager
Filename: 1M1804230079-10.ACJ	Test Dates: 05/08/2018	DUT Type: Portable Handset		Page 8 of 35

© 2018 PCTEST Engineering Laboratory, Inc.

REV 3.2.M

04/17/2018

© 2018 PCTEST Engineering Laboratory, Inc. All rights reserved. Unless otherwise specified, no part of this report may be reproduced or utilized in any part, form or by any means, electronic or mechanical, including photocopying and microfilm, without permission in writing from PCTEST Engineering Laboratory, Inc. If you have any questions about this international copyright or have an enquiry about obtaining additional rights to this report or assembly of contents thereof, please contact INFO@PCTEST.COM.

SPEAG Robotic System



E-field measurements are performed using the DASY5 automated dosimetric assessment system. The DASY5 is made by Schmid & Partner Engineering AG (SPEAG) in Zurich, Switzerland and consists of high precision robotics system (Staubli), robot controller, Intel CORE i7 computer, near-field probe, probe alignment sensor, and the HAC phantom. The robot is a six-axis industrial robot performing precise movements to position the probe to the location (points) of maximum electromagnetic field (EMF).



Figure 4-3
SPEAG Robotic System

System Hardware

A cell controller system contains the power supply, robot controller, teach pendant (Joystick), and a remote control used to drive the robot motors. The PC consists of the computer with operating system and RF Measurement Software DASY5 v52.8 (with HAC Extension), A/D interface card, monitor, mouse, and keyboard. The Staubli Robot is connected to the cell controller to allow software manipulation of the robot. A data acquisition electronic (DAE) circuit that performs the signal amplification, signal multiplexing, AD-conversion, offset measurements, mechanical surface detection, collision detection, etc. is connected to the Electro-optical coupler (EOC). The EOC performs the conversion from the optical into digital electric signal of the DAE and transfers data to the PC plug-in card.

FCC ID: ACJFZN1D	 PCTEST ENGINEERING LABORATORY, INC.	HAC (RF EMISSIONS) TEST REPORT	 Panasonic	Approved by: Quality Manager
Filename: 1M1804230079-10.ACJ	Test Dates: 05/08/2018	DUT Type: Portable Handset	Page 9 of 35	

System Electronics

The DAE consists of a highly sensitive electrometer-grade preamplifier with auto-zeroing, a channel and gain-switching multiplexer, a fast 16 bit AD-converter and a command decoder and control logic unit. Transmission to the PC-card is accomplished through an optical downlink for data and status information and an optical uplink for commands and clock lines. The mechanical probe mounting device includes two different sensor systems for frontal and sidewise probe contacts. They are also used for mechanical surface detection and probe collision detection. The robot uses its own controller with a built in VME-bus computer.

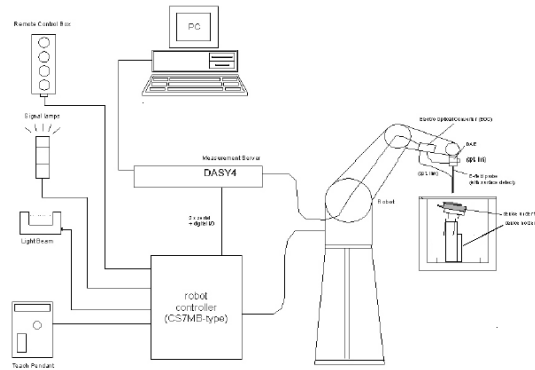



Figure 4-4
SPEAG Robotic System Diagram

DASY5 Instrumentation Chain

The first step of the evaluation is a linearization of the filtered input signal to account for the compression characteristics of the detector diode. The compensation depends on the input signal, the diode type and the DC-transmission factor from the diode to the evaluation electronics. If the exciting field is pulsed, the crest factor of the signal must be known to correctly compensate for peak power. The formula for each channel can be given as:

$$V_i = U_i + U_i^2 \cdot \frac{cf}{dcp_i}$$

with V_i	= compensated signal of channel i	(i = x, y, z)
U_i	= input signal of channel i	(i = x, y, z)
cf	= crest factor of exciting field	(DASY parameter)
dcp_i	= diode compression point	(DASY parameter)

FCC ID: ACJFZN1D	 PCTEST TECHNOLOGICAL LABORATORY, INC.	HAC (RF EMISSIONS) TEST REPORT	 Panasonic	Approved by: Quality Manager
Filename: 1M1804230079-10.ACJ	Test Dates: 05/08/2018	DUT Type: Portable Handset	Page 10 of 35	

From the compensated input signals the primary field data for each channel can be evaluated:

$$E - \text{fieldprobes} : \quad E_i = \sqrt{\frac{V_i}{Norm_i \cdot ConvF}}$$

with V_i = compensated signal of channel i (i = x, y, z)
 $Norm_i$ = sensor sensitivity of channel i (i = x, y, z)
 $\mu\text{V}/(\text{V}/\text{m})^2$ for E-field Probes
 $ConvF$ = sensitivity enhancement in solution
 E_i = electric field strength of channel i in V/m

The RSS value of the field components gives the total field strength (Hermitian magnitude):



$$E_{tot} = \sqrt{E_x^2 + E_y^2 + E_z^2}$$

The primary field data are used to calculate the derived field units.

The measurement/integration time per point, as specified by the system manufacturer is >500ms.

The signal response time is evaluated as the time required by the system to reach 90% of the expected final value after an on/off switch of the power source with an integration time of 500ms and a probe response time of <5 ms. In the current implementation, DASY5 waits longer than 100ms after having reached the grid point before starting a measurement, i.e., the response time uncertainty is negligible.

If the device under test does not emit a CW signal, the integration time applied to measure the electric field at a specific point may introduce additional uncertainties due to the discretization. The tolerances for the different systems had the worst-case of 2.6%.

FCC ID: ACJFZN1D	 PCTEST ENGINEERING LABORATORY, INC.	HAC (RF EMISSIONS) TEST REPORT	 Panasonic	Approved by: Quality Manager
Filename: 1M1804230079-10.ACJ	Test Dates: 05/08/2018	DUT Type: Portable Handset	Page 11 of 35	

5. MODULATION INTERFERENCE FACTOR

I. Measuring Modulation Interference Factors

For any specific fixed and repeatable modulated signal, a modulation interference factor (MIF, expressed in dB) may be determined that relates its interference potential to its steady-state RMS signal level or average power level. This factor is a function only of the audio-frequency amplitude modulation characteristics of the signal and is the same for field-strength and conducted power measurements. The MIF is valid only for a specific repeatable audio-frequency amplitude modulation characteristic; any change in modulation characteristic requires determination and application of a new MIF.

The MIF may be determined using a radiated RF field or a conducted RF signal:

- a. Using RF illumination or conducted coupling, apply the specific modulated signal in question to the measurement system at a level within its confirmed operating dynamic range.
- b. Measure the steady-state RMS level at the output of the fast probe or sensor.
- c. Measure the steady-state average level at the weighting output.
- d. Without changing the square-law detector or weighting system, and using RF illumination or conducted coupling, substitute for the specific modulated signal a 1 kHz, 80% amplitude modulated carrier at the same frequency and adjust its strength until the level at the weighting output equals the step c) measurement.
- e. Without changing the carrier level from step d), remove the 1 kHz modulation and again measure the steady-state RMS level indicated at the output of the fast probe or sensor.
- f. The MIF for the specific modulation characteristic is provided by the ratio of the step e) measurement to the step b) measurement, expressed in dB ($20 \times \log[(\text{step e})/(\text{step b})]$).



The following procedure was used to measure the MIF using the SPEAG Audio Interference Analyzer (AIA), Type No: SE UMS 170 CB, Serial No.: 1010:

1. The device was placed into a simulated call using a base station simulator or set to transmit using test software for a given mode.
2. The device was then set to continuously transmit at maximum power.
3. Using a coupler if needed, the device output signal was connected to the RF In port of the AIA, which was connected to a desktop computer. Alternatively, a radiated RF signal may be used with the AIA's built-in antenna.
4. The MIF measurement procedure in the DASY software was run, and the resulting MIF value was recorded.
5. Steps 1-4 were repeated for all CMRS air interfaces, frequency bands, and modulations.

The modulation interference factors obtained were applied to readings taken of the actual wireless device in order to obtain an accurate audio interference level reading using the formula:

$$\text{Audio Interference Level [dB(V/m)]} = 20 * \log[\text{Raw Field Value (V/m)}] + \text{MIF (dB)}$$

Because the MIF value is output power independent, MIF values for a given mode should be constant across all devices; however, per C63.19-2011 §D.7, MIF values should be measured for each device being evaluated. The voice modes for this device have been investigated in this section of the report.

FCC ID: ACJFZN1D	 PCTEST ENGINEERING LABORATORY, INC.	HAC (RF EMISSIONS) TEST REPORT	 Panasonic	Approved by: Quality Manager
Filename: 1M1804230079-10.ACJ	Test Dates: 05/08/2018	DUT Type: Portable Handset		Page 12 of 35

II. MIF Measurement Block Diagrams

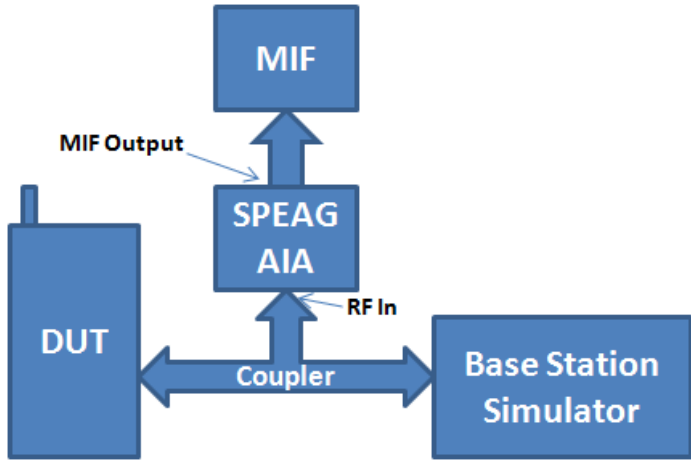

Figure 5-1
MIF Measurement Setup
for licensed modes

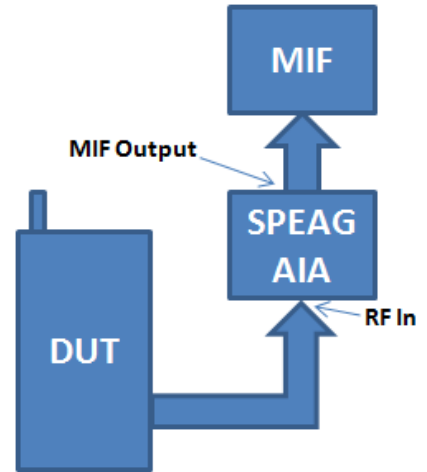

Figure 5-2
MIF Measurement Setup
for unlicensed modes

III. Measured Modulation Interference Factors:

Table 5-1
UMTS Modulation Interference Factors¹

Mode		UMTS V			UMTS II		
		4132	4183	4233	9262	9400	9538
UMTS	12.2 kbps RMC	-25.35	-23.32	-23.55	-24.29	-24.33	-24.11
	12.2 kbps AMR	-24.51	-23.74	-24.29	-24.18	-23.84	-24.21
	HSUPA Subtest1	-22.92	-22.82	-23.52	-23.25	-22.86	-23.12

¹ Note: Measured MIF values may be lower than sample MIF values provided in ANSI C63.19-2011 Annex D.7 Table D.5 due to manufacturing variations for each device, however per Annex D.7, the sample MIF values of Table D.5 are not intended to substitute for measurements of actual devices under test and their respective operating modes.



FCC ID: ACJFZN1D	 PCTEST ENGINEERING LABORATORY, INC.	HAC (RF EMISSIONS) TEST REPORT	 Panasonic	Approved by: Quality Manager
Filename: 1M1804230079-10.ACJ	Test Dates: 05/08/2018	DUT Type: Portable Handset		Page 13 of 35

Table 5-2
LTE FDD Modulation Interference Factors^{1,3,4}

LTE Band	Frequency [MHz]	Channel	Bandwidth [MHz]	Modulation	RB Size	RB Offset	MIF [dB]
2	1880.0	18900	20	16QAM	1	0	-9.69
5	836.5	20525	10	16QAM	1	0	-10.58
12	707.0	23095	10	16QAM	1	0	-10.57
13	782.0	23230	10	16QAM	1	0	-9.78
14	793.0	23330	10	16QAM	1	0	-9.98
66	1745.0	132322	20	16QAM	1	0	-9.68
66	1745.0	132322	20	QPSK	1	0	-14.89
66	1745.0	132322	20	16QAM	1	50	-10.00
66	1745.0	132322	20	16QAM	1	99	-10.04
66	1745.0	132322	20	16QAM	50	0	-15.87
66	1745.0	132322	20	16QAM	100	0	-16.84
66	1745.0	132322	15	16QAM	1	0	-9.71
66	1745.0	132322	10	16QAM	1	0	-9.75
66	1745.0	132322	5	16QAM	1	0	-9.55
66	1745.0	132322	3	16QAM	1	0	-9.68
66	1745.0	132322	1.4	16QAM	1	0	-10.55
66	1712.5	131997	5	16QAM	1	0	-9.70
66	1777.5	132647	5	16QAM	1	0	-10.84

Table 5-3
802.11b (2.4GHz, SISO) Modulation Interference Factors^{1,2}

Mode	802.11b MIF Measurements [dB]			
	Data Rate [Mbps]			
	1	2	5.5	11
802.11b	-9.81	-9.73	-8.86	-8.19

Table 5-4
802.11g (2.4GHz, SISO) Modulation Interference Factors^{1,2}

Mode	802.11g MIF Measurements [dB]							
	Data Rate [Mbps]							
	6	9	12	18	24	36	48	54
802.11g	-9.10	-8.33	-8.05	-7.65	-7.06	-6.88	-6.66	-6.90

¹ Note: Measured MIF values may be lower than sample MIF values provided in ANSI C63.19-2011 Annex D.7 Table D.5 due to manufacturing variations for each device, however per Annex D.7, the sample MIF values of Table D.5 are not intended to substitute for measurements of actual devices under test and their respective operating modes.

² Note: WIFI MIF values were found to be independent of the transmit channel.

³ Note: All FDD LTE bands were found to have substantially similar MIF values given similar RB, BW, and modulation configurations.



FCC ID: ACJFZN1D	 PCTEST TECHNOLOGICAL CORPORATION, INC.	HAC (RF EMISSIONS) TEST REPORT	 Panasonic	Approved by: Quality Manager
Filename: 1M1804230079-10.ACJ	Test Dates: 05/08/2018	DUT Type: Portable Handset	Page 14 of 35	

Table 5-5
802.11n (2.4GHz, 20MHz BW, SISO) Modulation Interference Factors^{1,2}

Mode	20MHz 802.11n (2.4GHz) MIF Measurements [dB]							
	Data Rate [Mbps]							
	6.5	13	19.5	26	39	52	58.5	65
802.11n	-9.03	-8.14	-7.34	-7.14	-6.95	-6.89	-6.95	-6.98

Table 5-6
802.11n (2.4GHz, 40MHz BW, SISO) Modulation Interference Factors^{1,2}

Mode	40MHz 802.11n (2.4GHz) MIF Measurements [dB]							
	Data Rate [Mbps]							
	13.5	27	40.5	54	81	108	121.5	135
802.11n	-7.28	-6.32	-6.47	-6.60	-7.12	-7.51	-7.46	-7.53

Table 5-7
802.11a (5GHz, 20MHz BW, SISO) Modulation Interference Factors^{1,2}

Mode	802.11a MIF Measurements [dB]							
	Data Rate [Mbps]							
	6	9	12	18	24	36	48	54
802.11a	-9.29	-8.52	-8.22	-7.83	-7.25	-7.10	-7.05	-7.19

Table 5-8
802.11n (5GHz, 20MHz BW, SISO) Modulation Interference Factors^{1,2}

Mode	20MHz BW 802.11n (5GHz) MIF Measurements [dB]							
	Data Rate [Mbps]							
	6.5	13	19.5	26	39	52	58.5	65
802.11n	-9.27	-8.35	-7.55	-7.38	-7.21	-7.18	-7.33	-7.25

Table 5-9
802.11ac (5GHz, 20MHz BW, SISO) Modulation Interference Factors^{1,2}

Mode	20MHz BW 802.11ac (5GHz) MIF Measurements [dB]								
	Data Rate [Mbps]								
	6.5	13	19.5	26	39	52	58.5	65	78
802.11ac	-9.26	-8.18	-7.53	-7.34	-7.17	-7.18	-7.27	-7.35	-7.30

Table 5-10
802.11n (5GHz, 40MHz BW, SISO) Modulation Interference Factors^{1,2}

Mode	40MHz BW 802.11n (5GHz) MIF Measurements [dB]							
	Data Rate [Mbps]							
	13.5	27	40.5	54	81	108	121.5	135
802.11n	-7.80	-6.89	-7.01	-7.02	-7.33	-7.33	-7.39	-7.32

¹ Note: Measured MIF values may be lower than sample MIF values provided in ANSI C63.19-2011 Annex D.7 Table D.5 due to manufacturing variations for each device, however per Annex D.7, the sample MIF values of Table D.5 are not intended to substitute for measurements of actual devices under test and their respective operating modes.

² Note: WIFI MIF values were found to be independent of the transmit channel.



FCC ID: ACJFZN1D	 PCTEST TECHNOLOGICAL LABORATORY, INC.	HAC (RF EMISSIONS) TEST REPORT	 Panasonic	Approved by: Quality Manager
Filename: 1M1804230079-10.ACJ	Test Dates: 05/08/2018	DUT Type: Portable Handset	Page 15 of 35	

Table 5-11
802.11ac (5GHz, 40MHz BW, SISO) Modulation Interference Factors^{1,2}



Mode	40MHz BW 802.11ac (5GHz) MIF Measurements [dB]								
	Data Rate [Mbps]								
	13.5	27	40.5	54	81	108	121.5	135	180
802.11ac	-7.08	-6.25	-6.26	-6.50	-6.94	-7.37	-7.15	-7.14	-7.51

Table 5-12
802.11ac (5GHz, 80MHz BW, SISO) Modulation Interference Factors^{1,2}

Mode	80MHz BW 802.11ac (5GHz) MIF Measurements [dB]									
	Data Rate [Mbps]									
	29.3	58.5	87.8	117	175.5	234	263.3	292.5	351	390
802.11ac	-6.18	-6.53	-7.01	-7.40	-7.56	-7.63	-7.73	-7.84	-7.86	-7.81

¹ Note: Measured MIF values may be lower than sample MIF values provided in ANSI C63.19-2011 Annex D.7 Table D.5 due to manufacturing variations for each device, however per Annex D.7, the sample MIF values of Table D.5 are not intended to substitute for measurements of actual devices under test and their respective operating modes.

² Note: WIFI MIF values were found to be independent of the transmit channel.

FCC ID: ACJFZN1D	 PCTEST ENGINEERING LABORATORY, INC.	HAC (RF EMISSIONS) TEST REPORT	 Panasonic	Approved by: Quality Manager
Filename: 1M1804230079-10.ACJ	Test Dates: 05/08/2018	DUT Type: Portable Handset		Page 16 of 35

6. RF CONDUCTED POWER MEASUREMENTS

I. Procedures Used to Establish RF Signal for HAC Testing

The handset was placed into a simulated call using a base station simulator in a shielded chamber. Such test signals offer a consistent means for testing HAC and are recommended for evaluating HAC. Measurements were taken with a fully charged battery. In order to verify that the device was tested and maintained at full power, this was configured with the base station simulator.

II. HAC Measurement Conditions

Output Power Verification

Maximum output power is verified on the High, Middle and Low channels for all applicable air interfaces. See Table 6-1 for air interface specific settings of transmit power parameters.

**Table 6-1
Power Control Parameters and Settings by Air Interface**

Air Interface:	Parameter Name:	Parameter Set To:
UMTS	TPC	"All 1's"
LTE	TPC	"Max Power"
WIFI	Mfr Configured	Mfr Specified

III. Setup Used to Measure RF Conducted Powers

Power measurements for licensed modes were performed using a base station simulator under digital average power. Power measurements for unlicensed modes were performed using a power meter and power sensor.

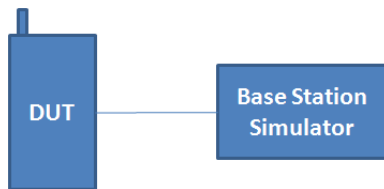

Figure 6-1
Power Measurement Setup for licensed modes

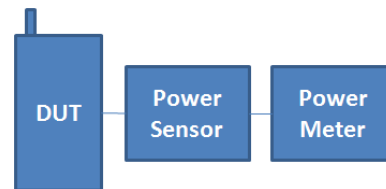



Figure 6-2
Power Measurement Setup for unlicensed modes

IV. UMTS Conducted Powers

Mode	3GPP 34.121 Subtest	Cellular Band [dBm]			PCS Band [dBm]		
		4132	4183	4233	9262	9400	9538
WCDMA	12.2 kbps RMC	23.38	23.58	23.45	23.25	23.29	23.10
	12.2 kbps AMR	23.39	23.55	23.43	23.24	23.18	23.11
HSUPA	Subtest 1	22.36	22.54	22.43	22.25	22.16	22.10

FCC ID: ACJFZN1D	 PCTEST ENGINEERING LABORATORY, INC.	HAC (RF EMISSIONS) TEST REPORT		Approved by: Quality Manager
Filename: 1M1804230079-10.ACJ	Test Dates: 05/08/2018	DUT Type: Portable Handset		Page 17 of 35

V. LTE Conducted Powers

a. LTE Band 12



Table 6-2
LTE Band 12 (707.5MHz) Conducted Powers – 10MHz Bandwidth

LTE Band 12 10 MHz Bandwidth					
Modulation	RB Size	RB Offset	Mid Channel	MPR Allowed per 3GPP [dB]	MPR [dB]
			23095 (707.5 MHz)		
			Conducted Power [dBm]		
QPSK	1	0	22.87	0	0
	1	25	22.88		0
	1	49	22.81		0
	25	0	21.94	0-1	1
	25	12	21.93		1
	25	25	21.91		1
16QAM	50	0	21.93	0-1	1
	1	0	22.06		1
	1	25	22.09		1
	1	49	22.05	0-2	1
	25	0	21.04		2
	25	12	21.04		2
	25	25	21.00		2
	50	0	21.01		2

Note: Since LTE Band 12 at 10MHz bandwidth does not support 3 non-overlapping channels, conducted power measurements were made only on the middle channel.

Table 6-3
LTE Band 12 (707.5MHz) Conducted Powers – 5MHz Bandwidth

LTE Band 12 5 MHz Bandwidth							
Modulation	RB Size	RB Offset	Low Channel	Mid Channel	High Channel	MPR Allowed per 3GPP [dB]	MPR [dB]
			23035 (701.5 MHz)	23095 (707.5 MHz)	23155 (713.5 MHz)		
			Conducted Power [dBm]				
QPSK	1	0	22.81	22.83	22.79	0	0
	1	12	22.92	22.87	22.88		0
	1	24	22.88	22.84	22.95		0
	12	0	21.97	21.94	21.83	0-1	1
	12	6	21.98	21.95	21.97		1
	12	13	21.95	21.90	21.96		1
16QAM	25	0	21.93	21.93	21.84	0-1	1
	1	0	22.17	22.19	22.14		1
	1	12	22.24	22.24	22.22		1
	1	24	22.24	22.21	22.25	0-2	1
	12	0	21.09	21.05	20.95		2
	12	6	21.10	21.06	21.07		2
	12	13	21.05	21.03	21.06		2
25	0	21.03	21.02	20.92	2		



FCC ID: ACJFZN1D	 PCTEST ENGINEERING LABORATORY, INC.	HAC (RF EMISSIONS) TEST REPORT	 Panasonic	Approved by: Quality Manager
Filename: 1M1804230079-10.ACJ	Test Dates: 05/08/2018	DUT Type: Portable Handset		Page 18 of 35

**Table 6-4
LTE Band 12 (707.5MHz) Conducted Powers – 3MHz Bandwidth**

LTE Band 12 3 MHz Bandwidth							
Modulation	RB Size	RB Offset	Low Channel	Mid Channel	High Channel	MPR Allowed per 3GPP [dB]	MPR [dB]
			23025 (700.5 MHz)	23095 (707.5 MHz)	23165 (714.5 MHz)		
			Conducted Power [dBm]				
QPSK	1	0	22.83	22.90	22.89	0	0
	1	7	22.91	22.96	22.90		0
	1	14	22.88	22.83	22.90		0
	8	0	21.86	21.90	21.92	0-1	1
	8	4	21.86	21.93	21.94		1
	8	7	21.93	21.92	21.93		1
16QAM	15	0	21.95	21.91	21.93	0-1	1
	1	0	22.16	22.22	22.23		1
	1	7	22.25	22.32	22.29		1
	1	14	22.26	22.22	22.22	0-2	1
	8	0	20.98	21.05	21.03		2
	8	4	20.99	20.97	20.99		2
	8	7	21.10	21.03	21.05	2	
	15	0	21.02	20.96	20.99	2	

**Table 6-5
LTE Band 12 (707.5MHz) Conducted Powers – 1.4MHz Bandwidth**

LTE Band 12 1.4 MHz Bandwidth							
Modulation	RB Size	RB Offset	Low Channel	Mid Channel	High Channel	MPR Allowed per 3GPP [dB]	MPR [dB]
			23017 (699.7 MHz)	23095 (707.5 MHz)	23173 (715.3 MHz)		
			Conducted Power [dBm]				
QPSK	1	0	22.75	22.83	22.80	0	0
	1	2	22.84	22.90	22.90		0
	1	5	22.73	22.78	22.83		0
	3	0	22.77	22.84	22.83		0
	3	2	22.82	22.87	22.88		0
	3	3	22.77	22.83	22.84	0	
16QAM	6	0	21.79	21.84	21.87	0-1	1
	1	0	22.11	22.17	22.13	0-1	1
	1	2	22.17	22.23	22.18		1
	1	5	22.10	22.16	22.13		1
	3	0	22.03	22.06	22.02		1
	3	2	22.05	22.10	22.08		1
3	3	22.00	22.04	22.04	1		
	6	0	20.94	20.98	21.01	0-2	2

FCC ID: ACJFZN1D	 PCTEST ENGINEERING LABORATORY, INC.	HAC (RF EMISSIONS) TEST REPORT	 Panasonic	Approved by: Quality Manager
Filename: 1M1804230079-10.ACJ	Test Dates: 05/08/2018	DUT Type: Portable Handset	Page 19 of 35	

b. LTE Band 13



**Table 6-6
LTE Band 13 (780.0MHz) Conducted Powers – 10MHz Bandwidth**

LTE Band 13 10 MHz Bandwidth					
Modulation	RB Size	RB Offset	Mid Channel	MPR Allowed per 3GPP [dB]	MPR [dB]
			23230 (782.0 MHz)		
			Conducted Power [dBm]		
QPSK	1	0	22.64	0	0
	1	25	22.70		0
	1	49	22.67		0
	25	0	21.73	0-1	1
	25	12	21.78		1
	25	25	21.71		1
	50	0	21.77		1
16QAM	1	0	21.78	0-1	1
	1	25	21.90		1
	1	49	21.84		1
	25	0	20.81	0-2	2
	25	12	20.90		2
	25	25	20.79		2
	50	0	20.85		2

**Table 6-7
LTE Band 13 (780.0MHz) Conducted Powers – 5MHz Bandwidth**

LTE Band 13 5 MHz Bandwidth					
Modulation	RB Size	RB Offset	Mid Channel	MPR Allowed per 3GPP [dB]	MPR [dB]
			23230 (782.0 MHz)		
			Conducted Power [dBm]		
QPSK	1	0	22.67	0	0
	1	12	22.68		0
	1	24	22.66		0
	12	0	21.78	0-1	1
	12	6	21.76		1
	12	13	21.71		1
	25	0	21.76		1
16QAM	1	0	21.85	0-1	1
	1	12	21.89		1
	1	24	21.88		1
	12	0	20.87	0-2	2
	12	6	20.86		2
	12	13	20.79		2
	25	0	20.84		2

Note: Since LTE Band 13 at 5MHz bandwidth does not support 3 non-overlapping channels, conducted power measurements were made only on the middle channel.

FCC ID: ACJFZN1D	 PCTEST ENGINEERING LABORATORY, INC.	HAC (RF EMISSIONS) TEST REPORT	 Panasonic	Approved by: Quality Manager
Filename: 1M1804230079-10.ACJ	Test Dates: 05/08/2018	DUT Type: Portable Handset		Page 20 of 35

c. LTE Band 14



Table 6-8
LTE Band 14 (793.0MHz) Conducted Powers – 10MHz Bandwidth

LTE Band 14 10 MHz Bandwidth					
Modulation	RB Size	RB Offset	Mid Channel	MPR Allowed per 3GPP [dB]	MPR [dB]
			23330 (793.0 MHz)		
			Conducted Power [dBm]		
QPSK	1	0	22.65	0	0
	1	25	22.63		0
	1	49	22.45		0
	25	0	21.71	0-1	1
	25	12	21.68		1
	25	25	21.63		1
	50	0	21.69		1
16QAM	1	0	21.82	0-1	1
	1	25	21.84		1
	1	49	21.65		1
	25	0	20.82	0-2	2
	25	12	20.79		2
	25	25	20.73		2
	50	0	20.80		2

Table 6-9
LTE Band 14 (793.0MHz) Conducted Powers – 5MHz Bandwidth

LTE Band 14 5 MHz Bandwidth					
Modulation	RB Size	RB Offset	Mid Channel	MPR Allowed per 3GPP [dB]	MPR [dB]
			23330 (793.0 MHz)		
			Conducted Power [dBm]		
QPSK	1	0	22.63	0	0
	1	12	22.55		0
	1	24	22.42		0
	12	0	21.71	0-1	1
	12	6	21.72		1
	12	13	21.66		1
	25	0	21.69		1
16QAM	1	0	21.89	0-1	1
	1	12	21.81		1
	1	24	21.70		1
	12	0	20.81	0-2	2
	12	6	20.80		2
	12	13	20.74		2
	25	0	20.77		2

Note: Since LTE Band 14 at 5MHz bandwidth does not support 3 non-overlapping channels, conducted power measurements were made only on the middle channel.

FCC ID: ACJFZN1D	 PCTEST ENGINEERING LABORATORY, INC.	HAC (RF EMISSIONS) TEST REPORT	 Panasonic	Approved by: Quality Manager
Filename: 1M1804230079-10.ACJ	Test Dates: 05/08/2018	DUT Type: Portable Handset		Page 21 of 35

d. LTE Band 5

Table 6-10
LTE Band 5 (836.5MHz) Conducted Powers – 10MHz Bandwidth

LTE Band 5 (Cell) 10 MHz Bandwidth					
Modulation	RB Size	RB Offset	Mid Channel	MPR Allowed per 3GPP [dB]	MPR [dB]
			20525 (836.5 MHz)		
			Conducted Power [dBm]		
QPSK	1	0	23.02	0	0
	1	25	23.11		0
	1	49	23.03		0
	25	0	22.22	0-1	1
	25	12	22.19		1
	25	25	22.15		1
16QAM	50	0	22.19	0-1	1
	1	0	22.38		1
	1	25	22.44		1
	1	49	22.36	0-2	1
	25	0	21.27		2
	25	12	21.27		2
	25	25	21.26	2	
	50	0	21.26	2	

Note: Since LTE Band 5 at 10MHz bandwidth does not support 3 non-overlapping channels, conducted power measurements were made only on the middle channel.

Table 6-11
LTE Band 5 (836.5MHz) Conducted Powers – 5MHz Bandwidth

LTE Band 5 (Cell) 5 MHz Bandwidth							
Modulation	RB Size	RB Offset	Low Channel	Mid Channel	High Channel	MPR Allowed per 3GPP [dB]	MPR [dB]
			20425 (826.5 MHz)	20525 (836.5 MHz)	20625 (846.5 MHz)		
			Conducted Power [dBm]				
QPSK	1	0	22.98	23.12	23.12	0	0
	1	12	22.97	23.11	23.04		0
	1	24	23.05	23.11	23.00		0
	12	0	22.03	22.20	22.14	0-1	1
	12	6	22.14	22.21	22.14		1
	12	13	22.11	22.17	22.06		1
16QAM	25	0	22.13	22.15	22.10	0-1	1
	1	0	22.30	22.49	22.44		1
	1	12	22.30	22.45	22.37		1
	1	24	22.40	22.43	22.29	0-2	1
	12	0	21.18	21.31	21.26		2
	12	6	21.25	21.32	21.26		2
	12	13	21.24	21.28	21.20	2	
	25	0	21.19	21.27	21.19	2	





FCC ID: ACJFZN1D	 PCTEST ENGINEERING LABORATORY, INC.	HAC (RF EMISSIONS) TEST REPORT	 Panasonic	Approved by: Quality Manager
Filename: 1M1804230079-10.ACJ	Test Dates: 05/08/2018	DUT Type: Portable Handset		Page 22 of 35

Table 6-12
LTE Band 5 (836.5MHz) Conducted Powers – 3MHz Bandwidth

LTE Band 5 (Cell) 3 MHz Bandwidth								
Modulation	RB Size	RB Offset	Low Channel	Mid Channel	High Channel	MPR Allowed per 3GPP [dB]	MPR [dB]	
			20415 (825.5 MHz)	20525 (836.5 MHz)	20635 (847.5 MHz)			
			Conducted Power [dBm]					
QPSK	1	0	22.95	23.12	23.05	0	0	
	1	7	23.07	23.20	23.12		0	
	1	14	22.95	22.98	22.97		0	
	8	0	22.02	22.18	21.99	0-1	1	
	8	4	22.03	22.17	22.08		1	
	8	7	21.91	22.14	22.04		1	
16QAM	15	0	21.91	22.16	22.07	0-1	1	
	1	0	22.29	22.45	22.39		1	
	1	7	22.39	22.48	22.41		1	
	16QAM	1	14	22.30	22.46	22.28	0-2	1
		8	0	21.14	21.29	21.18		2
		8	4	21.16	21.30	21.21		2
		8	7	21.15	21.28	21.17	2	
		15	0	21.09	21.16	21.15	2	

Table 6-13
LTE Band 5 (836.5MHz) Conducted Powers – 1.4MHz Bandwidth

LTE Band 5 (Cell) 1.4 MHz Bandwidth							
Modulation	RB Size	RB Offset	Low Channel	Mid Channel	High Channel	MPR Allowed per 3GPP [dB]	MPR [dB]
			20407 (824.7 MHz)	20525 (836.5 MHz)	20643 (848.3 MHz)		
			Conducted Power [dBm]				
QPSK	1	0	22.88	23.02	22.93	0	0
	1	2	22.96	23.11	22.99		0
	1	5	22.88	23.02	22.91		0
	3	0	22.89	23.06	22.94		0
	3	2	22.94	23.09	22.96		0
	3	3	22.88	23.05	22.93		0
	6	0	21.94	22.09	21.96	0-1	1
16QAM	1	0	22.21	22.39	22.23	0-1	1
	1	2	22.27	22.46	22.30		1
	1	5	22.22	22.36	22.18		1
	3	0	22.09	22.30	22.16		1
	3	2	22.16	22.33	22.18		1
	3	3	22.11	22.28	22.12	1	
6	0	21.10	21.26	21.13	0-2	2	

FCC ID: ACJFZN1D	 PCTEST ENGINEERING LABORATORY, INC.	HAC (RF EMISSIONS) TEST REPORT	 Panasonic	Approved by: Quality Manager
Filename: 1M1804230079-10.ACJ	Test Dates: 05/08/2018	DUT Type: Portable Handset	Page 23 of 35	

e. LTE Band 66

Table 6-14
LTE Band 66 (1745.0MHz) Conducted Powers – 20MHz Bandwidth

LTE Band 66 (AWS) 20 MHz Bandwidth							
Modulation	RB Size	RB Offset	Low Channel	Mid Channel	High Channel	MPR Allowed per 3GPP [dB]	MPR [dB]
			132072 (1720.0 MHz)	132322 (1745.0 MHz)	132572 (1770.0 MHz)		
			Conducted Power [dBm]				
QPSK	1	0	22.79	22.90	22.55	0	0
	1	50	22.64	22.71	22.71		0
	1	99	22.60	22.42	21.64		0
	50	0	21.48	21.78	21.57	0-1	1
	50	25	21.67	21.81	21.40		1
	50	50	21.60	21.65	21.02		1
16QAM	100	0	21.54	21.36	21.16	0-1	1
	1	0	21.98	22.12	21.81		1
	1	50	21.93	22.01	21.79		1
	1	99	21.88	21.71	20.84	0-2	1
	50	0	20.78	20.96	20.69		2
	50	25	20.82	20.91	20.48		2
	50	50	20.67	20.70	20.00		2
	100	0	20.63	20.64	20.20		2

Table 6-15
LTE Band 66 (1745.0MHz) Conducted Powers – 15MHz Bandwidth

LTE Band 66 (AWS) 15 MHz Bandwidth							
Modulation	RB Size	RB Offset	Low Channel	Mid Channel	High Channel	MPR Allowed per 3GPP [dB]	MPR [dB]
			132047 (1717.5 MHz)	132322 (1745.0 MHz)	132597 (1772.5 MHz)		
			Conducted Power [dBm]				
QPSK	1	0	22.80	22.90	22.75	0	0
	1	36	22.70	22.76	22.29		0
	1	74	22.63	22.55	21.60		0
	36	0	21.53	21.85	21.48	0-1	1
	36	18	21.68	21.84	21.29		1
	36	37	21.63	21.75	20.77		1
16QAM	75	0	21.48	21.57	21.02	0-1	1
	1	0	21.99	22.16	21.98		1
	1	36	21.96	22.03	21.61		1
	1	74	21.84	21.83	20.85	0-2	1
	36	0	20.73	20.92	20.53		2
	36	18	20.79	20.94	20.35		2
	36	37	20.68	20.86	19.91		2
	75	0	20.69	20.80	20.13		2

Table 6-16
LTE Band 66 (1745.0MHz) Conducted Powers – 10MHz Bandwidth

LTE Band 66 (AWS) 10 MHz Bandwidth							
Modulation	RB Size	RB Offset	Low Channel	Mid Channel	High Channel	MPR Allowed per 3GPP [dB]	MPR [dB]
			132022 (1715.0 MHz)	132322 (1745.0 MHz)	132622 (1775.0 MHz)		
			Conducted Power [dBm]				
QPSK	1	0	22.70	22.83	22.41	0	0
	1	25	22.71	22.75	22.12		0
	1	49	22.68	22.65	21.65		0
	25	0	21.50	21.87	21.21	0-1	1
	25	12	21.67	21.82	20.94		1
	25	25	21.69	21.77	20.53		1
16QAM	50	0	21.45	21.59	20.78	0-1	1
	1	0	21.92	22.11	21.63		1
	1	25	21.95	22.02	21.07		1
	1	49	21.94	22.00	20.82	0-2	1
	25	0	20.68	20.94	20.27		2
	25	12	20.84	20.92	20.06		2
	25	25	20.82	20.85	19.72		2
	50	0	20.62	20.89	19.85		2



FCC ID: ACJFZN1D	 PCTEST ENGINEERING LABORATORY, INC.	HAC (RF EMISSIONS) TEST REPORT	 Panasonic	Approved by: Quality Manager
Filename: 1M1804230079-10.ACJ	Test Dates: 05/08/2018	DUT Type: Portable Handset		Page 24 of 35

Table 6-17
LTE Band 66 (1745.0MHz) Conducted Powers – 5MHz Bandwidth



LTE Band 66 (AWS) 5 MHz Bandwidth							
Modulation	RB Size	RB Offset	Low Channel	Mid Channel	High Channel	MPR Allowed per 3GPP [dB]	MPR [dB]
			131997 (1712.5 MHz)	132322 (1745.0 MHz)	132647 (1777.5 MHz)		
Conducted Power [dBm]							
QPSK	1	0	22.78	22.94	22.32	0	0
	1	12	22.80	22.91	22.28		0
	1	24	22.82	22.95	22.18		0
	12	0	21.59	22.01	21.14	0-1	1
	12	6	21.63	22.02	21.03		1
	12	13	21.74	21.97	20.96		1
	25	0	21.71	21.99	20.95		1
16QAM	1	0	22.15	22.24	21.72	0-1	1
	1	12	22.07	22.17	21.88		1
	1	24	22.01	22.21	21.59		1
	12	0	21.02	21.07	20.48	0-2	2
	12	6	20.96	21.14	20.45		2
	12	13	20.97	21.10	20.37		2
	25	0	20.93	21.06	20.31		2

Table 6-18
LTE Band 66 (1745.0MHz) Conducted Powers – 3MHz Bandwidth

LTE Band 66 (AWS) 3 MHz Bandwidth							
Modulation	RB Size	RB Offset	Low Channel	Mid Channel	High Channel	MPR Allowed per 3GPP [dB]	MPR [dB]
			131987 (1711.5 MHz)	132322 (1745.0 MHz)	132657 (1778.5 MHz)		
Conducted Power [dBm]							
QPSK	1	0	22.89	22.95	22.30	0	0
	1	7	22.99	23.08	22.44		0
	1	14	22.76	22.97	22.23		0
	8	0	21.63	22.01	21.24	0-1	1
	8	4	21.62	22.05	21.26		1
	8	7	21.55	22.01	21.16		1
	15	0	21.44	22.02	21.20		1
16QAM	1	0	22.11	22.17	21.68	0-1	1
	1	7	22.18	22.31	21.99		1
	1	14	22.08	22.20	21.79		1
	8	0	21.02	21.06	20.52	0-2	2
	8	4	21.01	21.15	20.45		2
	8	7	20.99	21.11	20.38		2
	15	0	20.92	21.06	20.41		2

Table 6-19
LTE Band 66 (1745.0MHz) Conducted Powers – 1.4MHz Bandwidth

LTE Band 66 (AWS) 1.4 MHz Bandwidth							
Modulation	RB Size	RB Offset	Low Channel	Mid Channel	High Channel	MPR Allowed per 3GPP [dB]	MPR [dB]
			131979 (1710.7 MHz)	132322 (1745.0 MHz)	132665 (1779.3 MHz)		
Conducted Power [dBm]							
QPSK	1	0	22.78	22.89	21.76	0	0
	1	2	22.86	22.95	22.34		0
	1	5	22.75	22.90	22.02		0
	3	0	22.77	22.89	21.97		0
	3	2	22.83	22.92	22.09		0
	3	3	22.69	22.90	21.88		0
	6	0	21.82	21.93	21.13	0-1	1
16QAM	1	0	22.02	22.12	21.45	0-1	1
	1	2	22.03	22.10	21.39		1
	1	5	22.05	22.16	21.35		1
	3	0	21.88	22.05	21.18		1
	3	2	21.97	22.12	21.25		1
	3	3	21.82	21.86	21.12		1
	6	0	20.94	21.05	20.21	0-2	2

FCC ID: ACJFZN1D	 PCTEST ENGINEERING LABORATORY, INC.	HAC (RF EMISSIONS) TEST REPORT	 Panasonic	Approved by: Quality Manager
Filename: 1M1804230079-10.ACJ	Test Dates: 05/08/2018	DUT Type: Portable Handset		Page 25 of 35

f. LTE Band 2

Table 6-20
LTE Band 2 (1880.0MHz) Conducted Powers – 20MHz Bandwidth

LTE Band 2 (PCS) 20 MHz Bandwidth							
Modulation	RB Size	RB Offset	Low Channel	Mid Channel	High Channel	MPR Allowed per 3GPP [dB]	MPR [dB]
			18700 (1860.0 MHz)	18900 (1880.0 MHz)	19100 (1900.0 MHz)		
			Conducted Power [dBm]				
QPSK	1	0	23.34	23.23	23.07	0	0
	1	50	22.96	22.98	22.92		0
	1	99	23.15	23.14	22.88		0
	50	0	22.19	22.16	22.09	0-1	1
	50	25	22.10	22.11	22.03		1
	50	50	22.11	22.08	21.98		1
	100	0	22.18	22.10	22.05	1	
16QAM	1	0	22.67	22.61	22.43	0-1	1
	1	50	22.28	22.33	22.24		1
	1	99	22.46	22.45	22.20		1
	50	0	21.27	21.28	21.20	0-2	2
	50	25	21.19	21.19	21.12		2
	50	50	21.19	21.15	21.08		2
	100	0	21.31	21.25	21.12	2	

Table 6-21
LTE Band 2 (1880.0MHz) Conducted Powers – 15MHz Bandwidth

LTE Band 2 (PCS) 15 MHz Bandwidth							
Modulation	RB Size	RB Offset	Low Channel	Mid Channel	High Channel	MPR Allowed per 3GPP [dB]	MPR [dB]
			18675 (1857.5 MHz)	18900 (1880.0 MHz)	19125 (1902.5 MHz)		
			Conducted Power [dBm]				
QPSK	1	0	23.22	23.17	23.12	0	0
	1	36	23.02	23.01	22.94		0
	1	74	22.96	23.02	22.94		0
	36	0	22.20	22.16	22.06	0-1	1
	36	18	22.13	22.13	22.04		1
	36	37	22.10	22.10	22.00		1
	75	0	22.13	22.14	22.05	1	
16QAM	1	0	22.52	22.48	22.44	0-1	1
	1	36	22.30	22.36	22.27		1
	1	74	22.32	22.33	22.24		1
	36	0	21.24	21.18	21.08	0-2	2
	36	18	21.15	21.19	21.07		2
	36	37	21.10	21.14	21.00		2
	75	0	21.18	21.13	21.03	2	

Table 6-22
LTE Band 2 (1880.0MHz) Conducted Powers – 10MHz Bandwidth

LTE Band 2 (PCS) 10 MHz Bandwidth							
Modulation	RB Size	RB Offset	Low Channel	Mid Channel	High Channel	MPR Allowed per 3GPP [dB]	MPR [dB]
			18650 (1855.0 MHz)	18900 (1880.0 MHz)	19150 (1905.0 MHz)		
			Conducted Power [dBm]				
QPSK	1	0	23.30	23.21	22.93	0	0
	1	25	22.97	22.93	22.82		0
	1	49	23.10	23.12	22.78		0
	25	0	22.12	22.06	21.97	0-1	1
	25	12	22.09	22.04	21.92		1
	25	25	22.03	22.02	21.88		1
	50	0	22.08	22.06	21.92	1	
16QAM	1	0	22.58	22.51	22.26	0-1	1
	1	25	22.26	22.24	22.15		1
	1	49	22.39	22.44	22.10		1
	25	0	21.22	21.14	21.04	0-2	2
	25	12	21.17	21.15	20.99		2
	25	25	21.11	21.10	20.95		2
	50	0	21.15	21.10	20.98	2	



FCC ID: ACJFZN1D	 PCTEST ENGINEERING LABORATORY, INC.	HAC (RF EMISSIONS) TEST REPORT	 Panasonic	Approved by: Quality Manager
Filename: 1M1804230079-10.ACJ	Test Dates: 05/08/2018	DUT Type: Portable Handset		Page 26 of 35

Table 6-23
LTE Band 2 (1880.0MHz) Conducted Powers – 5MHz Bandwidth



LTE Band 2 (PCS) 5 MHz Bandwidth							
Modulation	RB Size	RB Offset	Low Channel	Mid Channel	High Channel	MPR Allowed per 3GPP [dB]	MPR [dB]
			18625 (1852.5 MHz)	18900 (1880.0 MHz)	19175 (1907.5 MHz)		
Conducted Power [dBm]							
QPSK	1	0	23.05	23.00	22.86	0	0
	1	12	22.98	22.94	22.80		0
	1	24	22.96	22.94	22.82		0
	12	0	22.11	22.03	21.91	0-1	1
	12	6	22.08	22.02	21.89		1
	12	13	21.96	22.00	21.84		1
	25	0	22.06	21.99	21.89		1
16QAM	1	0	22.35	22.31	22.17	0-1	1
	1	12	22.27	22.24	22.12		1
	1	24	22.21	22.21	22.02		1
	12	0	21.19	21.13	21.03	0-2	2
	12	6	21.16	21.12	20.99		2
	12	13	21.16	21.12	21.00		2
	25	0	21.12	21.08	20.96		2

Table 6-24
LTE Band 2 (1880.0MHz) Conducted Powers – 3MHz Bandwidth

LTE Band 2 (PCS) 3 MHz Bandwidth							
Modulation	RB Size	RB Offset	Low Channel	Mid Channel	High Channel	MPR Allowed per 3GPP [dB]	MPR [dB]
			18615 (1851.5 MHz)	18900 (1880.0 MHz)	19185 (1908.5 MHz)		
Conducted Power [dBm]							
QPSK	1	0	22.99	22.96	22.79	0	0
	1	7	23.05	23.01	22.78		0
	1	14	22.92	22.88	22.75		0
	8	0	22.01	21.98	21.82	0-1	1
	8	4	22.07	22.00	21.86		1
	8	7	22.01	21.97	21.80		1
	15	0	22.00	21.95	21.75		1
16QAM	1	0	22.19	22.23	22.08	0-1	1
	1	7	22.36	22.30	22.18		1
	1	14	22.28	22.19	22.06		1
	8	0	21.15	21.08	20.97	0-2	2
	8	4	21.16	21.11	20.97		2
	8	7	21.13	21.08	20.93		2
	15	0	21.00	21.05	20.91		2

Table 6-25
LTE Band 2 (1880.0MHz) Conducted Powers – 1.4MHz Bandwidth

LTE Band 2 (PCS) 1.4 MHz Bandwidth							
Modulation	RB Size	RB Offset	Low Channel	Mid Channel	High Channel	MPR Allowed per 3GPP [dB]	MPR [dB]
			18607 (1850.7 MHz)	18900 (1880.0 MHz)	19193 (1909.3 MHz)		
Conducted Power [dBm]							
QPSK	1	0	22.89	22.85	22.68	0	0
	1	2	22.97	22.90	22.77		0
	1	5	22.87	22.84	22.68		0
	3	0	22.91	22.86	22.73		0
	3	2	22.96	22.89	22.76		0
	3	3	22.91	22.83	22.72		0
	6	0	21.97	21.89	21.74		0-1
16QAM	1	0	22.23	22.15	22.01	0-1	1
	1	2	22.24	22.22	22.07		1
	1	5	22.12	22.12	21.98		1
	3	0	22.12	22.06	21.91		1
	3	2	22.16	22.09	21.95		1
	3	3	22.08	22.04	21.90		1
	6	0	21.11	21.04	20.90		0-2

FCC ID: ACJFZN1D		HAC (RF EMISSIONS) TEST REPORT		Approved by: Quality Manager
Filename: 1M1804230079-10.ACJ	Test Dates: 05/08/2018	DUT Type: Portable Handset		Page 27 of 35

VI. WIFI Conducted Powers

Table 6-26
IEEE 802.11b/g/n (2.4GHz, 20MHz BW, SISO) Average RF Power

2.4GHz Conducted Power [dBm]				
Freq [MHz]	Channel	IEEE Transmission Mode		
		802.11b	802.11g	802.11n
2412	1	18.47	14.31	13.15
2417	2	16.99	17.43	17.24
2437	6	18.55	17.65	17.37
2457	10	17.40	17.28	17.14
2462	11	18.54	14.40	13.02

Table 6-27
IEEE 802.11n (2.4GHz, 40MHz BW, SISO) Average RF Power

2.4GHz Conducted Power [dBm]		
Freq [MHz]	Channel	IEEE Transmission Mode
		802.11n
2422	3	12.61
2437	6	13.69
2452	9	12.44

Table 6-28
IEEE 802.11a/n/ac (5GHz, 20MHz BW, SISO) Average RF Power

5GHz (20MHz) Conducted Power [dBm]				
Freq [MHz]	Channel	IEEE Transmission Mode		
		802.11a	802.11n	802.11ac
5180	36	18.18	17.99	18.03
5200	40	18.10	17.93	17.97
5220	44	18.44	18.24	18.27
5240	48	17.53	18.45	18.47
5260	52	17.41	18.41	18.40
5280	56	17.26	18.09	18.06
5300	60	17.12	17.93	17.94
5320	64	17.86	17.71	17.73
5500	100	17.49	18.43	18.42
5600	120	17.31	18.23	18.32
5620	124	17.33	18.31	18.31
5720	144	17.31	18.01	18.01
5745	149	17.27	18.08	18.05
5785	157	17.38	18.21	18.22
5825	165	17.78	18.46	18.47





FCC ID: ACJFZN1D	 PCTEST ENGINEERING LABORATORY, INC.	HAC (RF EMISSIONS) TEST REPORT	 Panasonic	Approved by: Quality Manager
Filename: 1M1804230079-10.ACJ	Test Dates: 05/08/2018	DUT Type: Portable Handset	Page 28 of 35	

Table 6-29
IEEE 802.11n/ac (5GHz, 40MHz BW, SISO) Average RF Power

5GHz (40MHz) Conducted Power [dBm]			
Freq [MHz]	Channel	IEEE Transmission Mode	
		802.11n	802.11ac
5190	38	17.24	17.28
5230	46	16.65	16.57
5270	54	17.41	17.41
5310	62	17.12	17.15
5510	102	16.54	16.62
5590	118	16.28	16.28
5630	126	16.44	16.43
5710	142	16.56	16.58
5755	151	16.39	16.32
5795	159	16.59	16.60

Table 6-30
IEEE 802.11ac (5GHz, 80MHz BW, SISO) Average RF Power

5GHz (80MHz) Conducted Power [dBm]		
Freq [MHz]	Channel	IEEE Transmission Mode
		802.11ac
5210	42	16.45
5290	58	16.16
5530	106	16.55
5610	122	16.36
5690	138	16.48
5775	155	16.58

FCC ID: ACJFZN1D	 PCTEST TECHNICAL LABORATORY, INC.	HAC (RF EMISSIONS) TEST REPORT	 Panasonic	Approved by: Quality Manager
Filename: 1M1804230079-10.ACJ	Test Dates: 05/08/2018	DUT Type: Portable Handset		Page 29 of 35

7. JUSTIFICATION OF HELD TO EAR MODES TESTED

I. Analysis of RF Air Interface Technologies

An analysis was performed, following the guidance of §4.3 and §4.4 of the ANSI standard, of the RF air interface technologies being evaluated. The factors that will affect the RF interference potential were evaluated, and the worst-case operating modes were identified and used in the evaluation. A WD's interference potential is a function both of the WD's average near-field field strength and of the signal's audio-frequency amplitude modulation characteristics. Per §4.4, RF air interface technologies that have low power have been found to produce sufficiently low RF interference potential, so it is possible to exempt them from the product testing specified in Clause 5 of the ANSI standard. An RF air interface technology of a device is exempt from testing when its average antenna input power plus its MIF is $\leq 17\text{dBm}$ for all of its operating modes. RF air interface technologies exempted from testing in this manner are automatically assigned an M4 rating to be used in determining the overall rating for the WD.

The worst-case MIF plus the worst-case average antenna input power for all modes are investigated below to determine the testing requirements for this device.



II. Individual Mode Evaluations

Table 7-1
Max Power + MIF calculations for Low Power Exemptions

Air Interface	Maximum Average Power (dBm)	Worst Case MIF (dB)	Total (Power + MIF, dB)	C63.19 Testing Required
UMTS - RMC	23.58	-23.32	0.26	No
UMTS - AMR	23.55	-23.74	-0.19	No
HSPA	22.54	-22.82	-0.28	No
LTE - FDD	23.34	-9.55	13.79	No
2.4GHz WIFI	18.55	-6.32	12.23	No
5GHz WIFI	18.47	-6.18	12.29	No

III. Low-Power Exemption Conclusions

All air interfaces are exempt from RF emissions testing and rated M4 under the low power exemption of Clause 4 of ANSI C63.19-2011.

FCC ID: ACJFZN1D		HAC (RF EMISSIONS) TEST REPORT		Approved by: Quality Manager
Filename: 1M1804230079-10.ACJ	Test Dates: 05/08/2018	DUT Type: Portable Handset		Page 30 of 35



8. EQUIPMENT LIST

Table 8-1
Equipment List

Manufacturer	Model	Description	Cal Date	Cal Interval	Cal Due	Serial Number
Anritsu	MA2411B	Pulse Power Sensor	3/2/2018	Annual	3/2/2019	1207364
Anritsu	MA24106A	USB Power Sensor	4/18/2018	Annual	4/18/2019	1344556
Anritsu	ML2496A	Power Meter	10/9/2017	Annual	10/9/2018	1138001
Mini-Circuits	BW-N20W5	Power Attenuator	N/A	CBT*	N/A	1226
Pasternack	PE2237-20	Bidirectional Coupler	N/A	CBT*	N/A	N/A
Rohde & Schwarz	CMW500	Radio Communication tester	7/14/2017	Annual	7/14/2018	140144
Seekonk	NC-100	Torque Wrench (8" lb)	8/30/2016	Biennial	8/30/2018	N/A
SPEAG	AIA	Audio Interference Analyzer	N/A	CBT*	N/A	1010

Calibration traceable to the National Institute of Standards and Technology (NIST).

***Note: CBT (Calibrated Before Testing).** Prior to testing, the measurement paths containing a cable, attenuator, coupler or filter were connected to a calibrated source (i.e. a signal generator) to determine the losses of the measurement path. The power meter offset was then adjusted to compensate for the measurement system losses. This level offset is stored within the power meter before measurements are made. This calibration verification procedure applies to the system verification and output power measurements. The calibrated reading is then taken directly from the power meter after compensation of the losses for all final power measurements.

FCC ID: ACJFZN1D	 PCTEST TECHNOLOGICAL LABORATORY, INC.	HAC (RF EMISSIONS) TEST REPORT	 Panasonic	Approved by: Quality Manager
Filename: 1M1804230079-10.ACJ	Test Dates: 05/08/2018	DUT Type: Portable Handset	Page 31 of 35	

9. MEASUREMENT UNCERTAINTY

Table 9-1
Uncertainty Estimation Table

Wireless Communications Device Near-Field Measurement Uncertainty Estimation							
Uncertainty Component	Data (dB)	Data Type	Prob. Dist.	Divisor	Ci (E)	Unc. (dB)	Notes/Comments
Measurement System							
RF System Reflections	0.50	Tolerance	N	1.00	1	0.50	* Refl. < -20 dB
Field Probe Calibration	0.21	Tolerance	N	1.00	1	0.21	
Field Probe Isotropy	0.01	Tolerance	N	1.00	1	0.01	
Field Probe Frequency Response	0.135	Tolerance	N	1.00	1	0.14	
Field Probe Linearity	0.013	Tolerance	N	1.00	1	0.01	
Modulation Interference Factor	0.20	Tolerance	R	1.73	1	0.12	Applicable for M-rating testing
Boundary Effects	0.105	Accuracy	R	1.73	1	0.06	*
Probe Positioning Accuracy	0.20	Accuracy	R	1.73	1	0.12	*
Probe Positioner	0.050	Accuracy	R	1.73	1	0.03	*
Extrapolation/Interpolation	0.045	Tolerance	R	1.73	1	0.03	*
Resolution to 2mm error	0.21	Tolerance	N	1.00	1	0.21	
System Detection Limit	0.05	Tolerance	R	1.73	1	0.03	*
Readout Electronics	0.015	Tolerance	N	1.00	1	0.02	*
Integration Time	0.11	Tolerance	R	1.73	1	0.06	*
Response Time	0.033	Tolerance	R	1.73	1	0.02	*
Phantom Thickness	0.10	Tolerance	R	1.73	1	0.06	*
System Repeatability (Field x 2=power)	0.17	Tolerance	N	1.00	1	0.17	*
Test Sample Related							
Device Positioning Vertical	0.2	Tolerance	R	1.73	1	0.12	*
Device Positioning Lateral	0.045	Tolerance	R	1.73	1	0.03	*
Device Holder and Phantom	0.1	Tolerance	R	1.73	1	0.06	*
Power Drift	0.21	Tolerance	R	1.73	1	0.12	
<i>Combined Standard Uncertainty (k=1)</i>						0.66	16.3%
<i>Expanded Uncertainty [95% confidence]</i>						1.31	32.6%
<i>Expanded Uncertainty [95% confidence] on Field</i>						0.66	16.3%

Notes:

1. Test equipments are calibrated according to techniques outlined in NIS81, NIS3003 and NIST Tech Note 1297. All equipments have traceability according to NIST. Measurement Uncertainties are defined in further detail in NIS 81 and NIST Tech Note 1297 and UKAS M3003.
2. * Uncertainty specifications from Schmidt & Partner Engineering AG (not site specific)



Measurement uncertainty reflects the quality and accuracy of a measured result as compared to the true value. Such statements are generally required when stating results of measurements so that it is clear to the intended audience that the results may differ when reproduced by different facilities. Measurement results vary due to the measurement uncertainty of the instrumentation, measurement technique, and test engineer. Most uncertainties are calculated using the tolerances of the instrumentation used in the measurement, the measurement setup variability, and the technique used in performing the test. While not generally included, the variability of the equipment under test also figures into the overall measurement uncertainty. Another component of the overall uncertainty is based on the variability of repeated measurements (so-called Type A uncertainty). This may mean that the Hearing Aid immunity tests may have to be repeated by taking down the test setup and resetting it up so that there are a statistically significant number of repeat measurements to identify the measurement uncertainty. By combining the repeat measurement results with that of the instrumentation chain using the technique contained in NIS 81 and NIS 3003, the overall measurement uncertainty was estimated.

FCC ID: ACJFZN1D	PCTEST <small>TECHNOLOGICAL LABORATORY, INC.</small>	HAC (RF EMISSIONS) TEST REPORT		Approved by: Quality Manager
Filename: 1M1804230079-10.ACJ	Test Dates: 05/08/2018	DUT Type: Portable Handset	Page 32 of 35	

10. CONCLUSION

The measurements indicate that the wireless communications device complies with the HAC limits specified in accordance with the ANSI C63.19 Standard and FCC WT Docket No. 01-309 RM-8658. Precise laboratory measures were taken to assure repeatability of the tests. The tested device complies with the requirements in respect to all parameters specific to the test. The test results and statements relate only to the item(s) tested.

Please note that the M-rating for this equipment only represents the field interference possible against a hypothetical and typical hearing aid. The measurement system and techniques presented in this evaluation are proposed in the ANSI standard as a means of best approximating wireless device compatibility with a hearing-aid. The literature is under continual re-construction.

FCC ID: ACJFZN1D	 PCTEST ENGINEERING LABORATORY, INC.	HAC (RF EMISSIONS) TEST REPORT	 Panasonic	Approved by: Quality Manager
Filename: 1M1804230079-10.ACJ	Test Dates: 05/08/2018	DUT Type: Portable Handset	Page 33 of 35	



© 2018 PCTEST Engineering Laboratory, Inc.

REV 3.2.M
04/17/2018



© 2018 PCTEST Engineering Laboratory, Inc. All rights reserved. Unless otherwise specified, no part of this report may be reproduced or utilized in any part, form or by any means, electronic or mechanical, including photocopying and microfilm, without permission in writing from PCTEST Engineering Laboratory, Inc. If you have any questions about this international copyright or have an enquiry about obtaining additional rights to this report or assembly of contents thereof, please contact INFO@PCTEST.COM.

11. REFERENCES

1. ANSI/IEEE C63.19-2011, "American National Standard for Methods of Measurement of Compatibility between Wireless Communication Devices and Hearing Aids.", New York, NY, IEEE, May 2011
2. FCC Office of Engineering and Technology KDB, "285076 D01 HAC Guidance v05," September 13, 2017
3. FCC Office of Engineering and Technology KDB, "285076 D02 T-Coil Testing for CMRS IP v03," September 13, 2017
4. FCC Public Notice DA 06-1215, *Wireless Telecommunications Bureau and Office of Engineering and Technology Clarify Use of Revised Wireless Phone Hearing Aid Compatibility Standard*, June 6, 2006
5. FCC 3G Review Guidance, Laboratory Division OET FCC, May/June 2006
6. Berger, H. S., "Compatibility Between Hearing Aids and Wireless Devices," Electronic Industries Forum, Boston, MA, May, 1997
7. Berger, H. S., "Hearing Aid and Cellular Phone Compatibility: Working Toward Solutions," *Wireless Telephones and Hearing Aids: New Challenges for Audiology*, Gallaudet University, Washington, D.C., May, 1997 (To be reprinted in the American Journal of Audiology).
8. Berger, H. S., "Hearing Aid Compatibility with Wireless Communications Devices," IEEE International Symposium on Electromagnetic Compatibility, Austin, TX, August, 1997.
9. Bronaugh, E. L., "Simplifying EMI Immunity (Susceptibility) Tests in TEM Cells," in the 1990 IEEE International Symposium on Electromagnetic Compatibility Symposium Record, Washington, D.C., August 1990, pp. 488-491
10. Byrne, D. and Dillon, H., The National Acoustics Laboratory (NAL) New Procedure for Selecting the Gain and Frequency Response of a Hearing Aid, *Ear and Hearing* 7:257-265, 1986.
11. Crawford, M. L., "Measurement of Electromagnetic Radiation from Electronic Equipment using TEM Transmission Cells," U.S. Department of Commerce, National Bureau of Standards, NBSIR 73-306, Feb. 1973.
12. Crawford, M. L., and Workman, J. L., "Using a TEM Cell for EMC Measurements of Electronic Equipment," U.S. Department of Commerce, National Bureau of Standards. Technical Note 1013, July 1981.
13. Decker, W. F., Crawford, M. L., and Wilson, W. A., "Construction of a Large Transverse Electromagnetic Cell", U.S. Department of Commerce, National Bureau of Standards, Technical Note 1011, Feb. 1979.
14. EHIMA GSM Project, Development phase, Project Report (1st part) Revision A. Technical-Audiological Laboratory and Telecom Denmark, October 1993.

FCC ID: ACJFZN1D	 PCTEST ENGINEERING LABORATORY, INC.	HAC (RF EMISSIONS) TEST REPORT	 Panasonic	Approved by: Quality Manager
Filename: 1M1804230079-10.ACJ	Test Dates: 05/08/2018	DUT Type: Portable Handset	Page 34 of 35	

15. EHIMA GSM Project, Development phase, Part II Project Report. Technical-Audiological Laboratory and Telecom Denmark, June 1994.
16. EHIMA GSM Project Final Report, Hearing Aids and GSM Mobile Telephones: Interference Problems, Methods of Measurement and Levels of Immunity. Technical-Audiological Laboratory and Telecom Denmark, 1995.
17. HAMPIS Report, Comparison of Mobile phone electromagnetic near field with an upscaled electromagnetic far field, using hearing aid as reference, 21 October 1999.
18. Hearing Aids/GSM, Report from OTWIDAM, Technical-Audiological Laboratory and Telecom Denmark, April 1993.
19. IEEE 100, The Authoritative Dictionary of IEEE Standards Terms, Seventh Edition.
20. Joyner, K. H, et. al., Interference to Hearing Aids by the New Digital Mobile Telephone System, Global System for Mobile (GSM) Communication Standard, National Acoustic Laboratory, Australian Hearing Series, Sydney 1993.
21. Joyner, K. H., et. al., Interference to Hearing Aids by the Digital Mobile Telephone System, Global System for Mobile Communications (GSM), NAL Report #131, National Acoustic Laboratory, Australian Hearing Series, Sydney, 1995.
22. Konigstein, D., and Hansen, D., "A New Family of TEM Cells with enlarged bandwidth and Optimized working Volume," in the Proceedings of the 7th International Symposium on EMC, Zurich, Switzerland, March 1987; 50:9, pp. 127-132.
23. Kuk, F., and Hjorstgaard, N. K., "Factors affecting interference from digital cellular telephones," Hearing Journal, 1997; 50:9, pp 32-34.
24. Ma, M. A., and Kanda, M., "Electromagnetic Compatibility and Interference Metrology," U.S. Department of Commerce, National Bureau of Standards, Technical Note 1099, July 1986, pp. 17-43.
25. Ma, M. A., Sreenivashiah, I. , and Chang, D. C., "A Method of Determining the Emission and Susceptibility Levels of Electrically Small Objects Using a TEM Cell," U.S. Department of Commerce, National Bureau of Standards, Technial Note 1040, July 1981.
26. McCandless, G. A., and Lyregaard, P. E., Prescription of Gain/Output (POGO) for Hearing Aids, Hearing Instruments 1:16-21, 1983
27. Skopec, M., "Hearing Aid Electromagnetic Interference from Digital Wireless Telephones, "IEEE Transactions on Rehabilitation Engineering, vol. 6, no. 2, pp. 235-239, June 1998.
28. Technical Report, GSM 05.90, GSM EMC Considerations, European Telecommunications Standards Institute, January 1993.
29. Victorian, T. A., "Digital Cellular Telephone Interference and Hearing Aid Compatibility—an Update," Hearing Journal 1998; 51:10, pp. 53-60
30. Wong, G. S. K., and Embleton, T. F. W., eds., AIP Handbook of Condenser Microphones: Theory, Calibration and Measurements, AIP Press.

FCC ID: ACJFZN1D	 PCTEST TECHNOLOGICAL LABORATORY, INC.	HAC (RF EMISSIONS) TEST REPORT	 Panasonic	Approved by: Quality Manager
Filename: 1M1804230079-10.ACJ	Test Dates: 05/08/2018	DUT Type: Portable Handset	Page 35 of 35	