

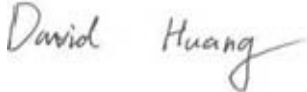

# RF TEST REPORT



Report No.: 16040115-FCC-R3

Supersede Report No.: N/A

Applicant	Panasonic corporation of North America	
Product Name	Car Audio System with Bluetooth and Wi-Fi	
Model No.	AH1801	
Serial No.	N/A	
Test Standard	FCC Part 15.407(h): 2015, KDB905462 D02 v02	
Test Date	April 20 to September 23, 2016	
Issue Date	October 15, 2016	
Test Result	<input checked="" type="checkbox"/> Pass <input type="checkbox"/> Fail	
Equipment complied with the specification	<input checked="" type="checkbox"/>	
Equipment did not comply with the specification	<input type="checkbox"/>	
		
Morri Huang Test Engineer	David Huang Checked By	
This test report may be reproduced in full only Test result presented in this test report is applicable to the tested sample only		

Issued by:

**SIEMIC (SHENZHEN-CHINA) LABORATORIES**

Zone A, Floor 1, Building 2 Wan Ye Long Technology Park

South Side of Zhoushi Road, Bao' an District, Shenzhen, Guangdong China 518108

Phone: +86 0755 2601 4629801 Email: [China@siemic.com.cn](mailto:China@siemic.com.cn)

## Laboratories Introduction

SIEMIC, headquartered in the heart of Silicon Valley, with superior facilities in US and Asia, is one of the leading independent testing and certification facilities providing customers with one-stop shop services for Compliance Testing and Global Certifications.



In addition to testing and certification, SIEMIC provides initial design reviews and compliance management throughout a project. Our extensive experience with China, Asia Pacific, North America, European, and International compliance requirements, assures the fastest, most cost effective way to attain regulatory compliance for the global markets.

### Accreditations for Conformity Assessment

Country/Region	Scope
USA	EMC, RF/Wireless, SAR, Telecom
Canada	EMC, RF/Wireless, SAR, Telecom
Taiwan	EMC, RF, Telecom, SAR, Safety
Hong Kong	RF/Wireless, SAR, Telecom
Australia	EMC, RF, Telecom, SAR, Safety
Korea	EMI, EMS, RF, SAR, Telecom, Safety
Japan	EMI, RF/Wireless, SAR, Telecom
Singapore	EMC, RF, SAR, Telecom
Europe	EMC, RF, SAR, Telecom, Safety

Test Report No.	16040115-FCC-R3
Page	3 of 78

This page has been left blank intentionally.

# CONTENTS

1. REPORT REVISION HISTORY .....	5
2. CUSTOMER INFORMATION .....	5
3. TEST SITE INFORMATION .....	5
4. EQUIPMENT UNDER TEST (EUT) INFORMATION .....	6
5. TEST SUMMARY .....	8
6. MEASUREMENTS, EXAMINATION AND DERIVED RESULTS .....	9
6.1 DYNAMIC FREQUENCY SELECTION (DFS).....	9
6.2 TEST PROCEDURE .....	17
6.3 INITIAL CHANNEL AVAILABILITY CHECK TIME.....	26
6.4 RADAR BURST AT THE BEGINNING OF THE CHANNEL AVAILABILITY CHECK TIME.....	28
6.5 RADAR BURST AT THE END OF THE CHANNEL AVAILABILITY CHECK TIME.....	30
6.6 IN-SERVICE MONITORING FOR CHANNEL MOVE TIME, CHANNEL CLOSING TRANSMISSION TIME AND NON- OCCUPANCY PERIOD .....	32
6.7 STATISTICAL PERFORMANCE CHECK .....	34
ANNEX A. TEST INSTRUMENT.....	75
ANNEX C. II. SUPPORTING EQUIPMENT DESCRIPTION .....	76
ANNEX D. USER MANUAL / BLOCK DIAGRAM / SCHEMATICS / PARTLIST .....	77
ANNEX E. DECLARATION OF SIMILARITY.....	78

## 1. Report Revision History

Report No.	Report Version	Description	Issue Date
16040115-FCC-R3	NONE	Original	October 1, 2016
16040115-FCC-R3	V1	Changing antenna gain	October 15, 2016

## 2. Customer information

Applicant Name	Panasonic corporation of North America
Applicant Add	Two Riverfront Plaza, 9th Floor, Newark, New Jersey NJ07102-5490 USA
Manufacturer	Panasonic Automotive Systems de Mexico S.A. de C.V.
Manufacturer Add	88785 Mike Allen1231, Parque Industrial Reynosa, Reynosa Tamaulipas, Mexico.

## 3. Test site information

Lab performing tests	SIEMIC (Shenzhen-China) LABORATORIES
Lab Address	Zone A, Floor 1, Building 2 Wan Ye Long Technology Park South Side of Zhoushi Road, Bao' an District, Shenzhen, Guangdong China 518108
FCC Test Site No.	718246
IC Test Site No.	4842E-1
Test Software	Radiated Emission Program-To Shenzhen v2.0

## 4. Equipment under Test (EUT) Information

Description of EUT:	Car Audio System with Bluetooth and Wi-Fi
Main Model:	AH1801
Serial Model:	N/A
Date EUT received:	April 25, 2016
Test Date(s):	April 20 to September 23, 2016
Equipment Category :	NII
Antenna Gain:	<p>Bluetooth(2.4G): -0.53 dBi  WIFI(2.4G): -0.53 dBi  WIFI(5150-5350MHz): -0.98 dBi  WIFI(5470-5725MHz): -0.26 dBi  WIFI(5725-5850MHz): -0.63 dBi  ( Note: The AH1801 will be sold without antenna, this antenna only used for DFS or radiated spurious emission test. )</p>
Type of Modulation:	<p>802.11b: DSSS  802.11a/g/n20/n40/ac20/ac40/ac80: OFDM</p>
RF Operating Frequency (ies):	<p>Bluetooth: 2402-2480 MHz  802.11b/g: 2412-2462 MHz (TX/RX)  802.11n20: 2412-2462MHz ;5180-5320 MHz; 5500-5700 MHz; 5745-5825 MHz; (TX/RX)  802.11n40: 2422-2452 MHz (TX/RX); 5190-5310 MHz; 5510-5710 MHz;5755-5795 MHz; ( TX/RX)  802.11 a: 5180-5320 MHz; 5500-5700 MHz; 5745-5825 MHz (TX/RX)  802.11ac 20: 5180-5320 MHz; 5500-5700 MHz; 5745-5825 MHz; (TX/RX)  802.11ac 40: 5190-5310 MHz; 5510-5710 MHz; 5755-5795 MHz; ( TX/RX)  802.11ac 80: 5210-5290 MHz; 5530-5690 MHz; 5775 MHz; (TX/RX)</p>

Test Report No.	16040115-FCC-R3
Page	7 of 78

Max. Output Power:

802.11a: 8.58 dBm  
802.11n(20M): 7.78 dBm  
802.11n(40M): 7.96 dBm  
802.11ac(20M): 7.68 dBm  
802.11ac(40M): 7.96 dBm  
802.11ac(80M): 5.21 dBm

Number of Channels:

Bluetooth: 79CH  
WIFI :802.11b/g: 11CH  
WIFI :802.11a: 24CH  
WIFI :802.11n20: 11CH(2.4GHz); 24CH(5GHz)  
WIFI :802.11n40: 9CH(2.4GHz); 12CH(5GHz)  
WIFI :802.11ac20: 24CH  
WIFI :802.11ac40: 12CH  
WIFI :802.11ac80: 6CH

Input Power: DC 13.2V, 5A

Trade Name : Panasonic

FCC ID: ACJAH1801

## 5. Test Summary

The product was tested in accordance with the following specifications.

All testing has been performed according to below product classification:

Test Item	Test standard	Test Method/Procedure	Result
UNII Detection Bandwidth	47CFR15.407 (h)	905462 D02 UNII DFS Compliance Procedures New Rules v02	Pass
Initial Channel Availability Check Time	47CFR15.407 (h)	905462 D02 UNII DFS Compliance Procedures New Rules v02	Pass
Radar Burst at the Beginning of the Channel Availability Check Time	47CFR15.407 (h)	905462 D02 UNII DFS Compliance Procedures New Rules v02	Pass
Radar Burst at the End of the Channel Availability Check Time	47CFR15.407 (h)	905462 D02 UNII DFS Compliance Procedures New Rules v02	Pass
In-Service Monitoring - Channel Move Time	47CFR15.407 (h)	905462 D02 UNII DFS Compliance Procedures New Rules v02	Pass
In-Service Monitoring - Channel Closing Transmission Time	47CFR15.407 (h)	905462 D02 UNII DFS Compliance Procedures New Rules v02	Pass
In-Service Monitoring - Non-Occupancy Period	47CFR15.407 (h)	905462 D02 UNII DFS Compliance Procedures New Rules v02	Pass
Statistical Performance Check	47CFR15.407 (h)	905462 D02 UNII DFS Compliance Procedures New Rules v02	Pass
Remark	N/A		

### Measurement Uncertainty

Emissions		
Test Item	Description	Uncertainty
Dynamic frequency selection (DFS) Conducted Measurement	Confidence level of approximately 95% (in the case where distributions are normal), with a coverage factor of 2	±1.5dB

## 6. Measurements, Examination And Derived Results

### 6.1 Dynamic Frequency Selection (DFS)

#### 6.1.1 General introduction

##### Interference Threshold values, Master or Client incorporating In-Service Monitoring

Maximum Transmit Power	Value (see note)
≥ 200 milliwatt	-64 dBm
EIRP < 200 milliwatt and power spectral density < 10 dBm/MHz	-62 dBm
EIRP < 200 milliwatt that do not meet the power spectra density requirement	-64 dBm

Note 1: This is the level at the input of the receiver assuming a 0 dBi receive antenna.

Note 2: Throughout these test procedures an additional 1 dB has been added to the amplitude of the test transmission waveforms to account for variations in measurement equipment. This will ensure that the test signal is at or above the detection threshold level to trigger a DFS response.

Note3: EIRP is based on the highest antenna gain. For MIMO devices refer to KDB Publication 662911 D01.

##### DFS Response requirement values

Parameter	Value
Non-occupancy period	Minimum 30 minutes
Channel Availability Check Time	60 seconds
Channel Move Time	10 seconds See Note 1.
Channel Closing Transmission Time	200 milliseconds + an aggregate of 60 milliseconds over remaining 10 second period. See Notes 1 and 2.
U-NII Detection Bandwidth	Minimum 100% of the UNII 99% transmission power bandwidth See Note 3.

Note 1: Channel Move Time and the Channel Closing Transmission Time should be performed with Radar Type 0. The measurement timing begins at the end of the Radar Type 0 burst.

Note 2: The Channel Closing Transmission Time is comprised of 200 milliseconds starting at the beginning of the Channel Move Time plus any additional intermittent control signals required facilitating a Channel move (an aggregate of 60 milliseconds) during the remainder of the 10 second period. The aggregate duration of control signals will not count quiet periods in between transmissions.

Note 3: During the U-NII Detection Bandwidth detection test, radar type 0 should be used. For each frequency step the minimum percentage of detection is 90 percent. Measurements are performed with no data traffic.

## Radar Test Waveforms

This section provides the parameters for required test waveforms, minimum percentage of successful detections, and the minimum number of trials that must be used for determining DFS conformance. Step intervals of 0.1 microsecond for Pulse Width, 1 microsecond for PRI, 1 MHz for chirp width and 1 for the number of pulses will be utilized for the random determination of specific test waveforms

### 1. Short Pulse Radar Test Waveforms

Radar Type	Pulse Width (µsec)	PRI (µsec)	Number of Pulses	Minimum Percentage of Successful Detection	Minimum
0	1	1428	18	See Note 1	See Note 1
1	1	Test A: 15 unique PRI values randomly selected from the list of 23 PRI values in Table 5a	Roundup $\{ (1/360) * (19 * 10^6 / PRI_{\mu sec}) \}$	60%	30
		60% 30 Test B: 15 unique PRI values randomly selected within the range of 518-3066 µsec, with a minimum increment of 1 µsec, excluding PRI values selected in Test A	-		
2	1-5	150-230	23-29	60%	30
3	6-10	200-500	16-18	60%	30
4	11-20	200-500	12-16	60%	30
Aggregate (Radar Types 1-4)				80%	120
Note 1: Short Pulse Radar Type 0 should be used for the detection bandwidth test, channel move time, and channel closing time tests.					

### 2. Long Pulse Radar Test Waveform

Radar Type	Pulse Width (µsec)	Chirp Width (MHz)	PRI (µsec)	Number of Pulses per Burst	Number of Bursts	Minimum Percentage of Successful Detection	Minimum Trials
5	50-100	5-20	1000-2000	1-3	8-20	80%	30

The parameters for this waveform are randomly chosen. Thirty unique waveforms are required for the Long Pulse radar test signal. If more than 30 waveforms are used for the Long Pulse radar test signal, then each additional waveform must also be unique and not repeated from the previous waveforms.

Each waveform is defined as follows:

- 1) The transmission period for the Long Pulse Radar test signal is 12 seconds.

- 2) There are a total of 8 to 20 Bursts in the 12 second period, with the number of Bursts being randomly chosen. This number is Burst\_Count.
- 3) Each Burst consists of 1 to 3 pulses, with the number of pulses being randomly chosen. Each Burst within the 12 second sequence may have a different number of pulses.
- 4) The pulse width is between 50 and 100 microseconds, with the pulse width being randomly chosen. Each pulse within a Burst will have the same pulse width. Pulses in different Bursts may have different pulse widths.
- 5) Each pulse has a linear FM chirp between 5 and 20 MHz, with the chirp width being randomly chosen. Each pulse within a Burst will have the same chirp width. Pulses in different Bursts may have different chirp widths. The chirp is centered on the pulse. For example, with a radar frequency of 5300 MHz and a 20 MHz chirped signal, the chirp starts at 5290 MHz and ends at 5310 MHz.
- 6) If more than one pulse is present in a Burst, the time between the pulses will be between 1000 and 2000 microseconds, with the time being randomly chosen. If three pulses are present in a Burst, the time between the first and second pulses is chosen independently of the time between the second and third pulses.
- 7) The 12 second transmission period is divided into even intervals. The number of intervals is equal to Burst\_Count. Each interval is of length  $(12,000,000 / \text{Burst\_Count})$  microseconds. Each interval contains one Burst. The start time for the Burst, relative to the beginning of the interval, is between 1 and  $[(12,000,000 / \text{Burst\_Count}) - (\text{Total Burst Length}) + (\text{One Random PRI Interval})]$  microseconds, with the start time being randomly chosen. The step interval for the start time is 1 microsecond. The start time for each Burst is chosen independently.

A representative example of a Long Pulse radar test waveform:

- 1) The total test signal length is 12 seconds.
- 2) 8 Bursts are randomly generated for the Burst\_Count.
- 3) Burst 1 has 2 randomly generated pulses.
- 4) The pulse width (for both pulses) is randomly selected to be 75 microseconds.
- 5) The PRI is randomly selected to be at 1213 microseconds.
- 6) Bursts 2 through 8 are generated using steps 3 – 5.
- 7) Each Burst is contained in even intervals of 1,500,000 microseconds. The starting location for Pulse 1, Burst 1 is randomly generated (1 to 1,500,000 minus the total Burst 1 length + 1 random PRI interval) at the 325,001 microsecond step. Bursts 2 through 8 randomly fall in successive 1,500,000 microsecond intervals (i.e. Burst 2 falls in the 1,500,001 – 3,000,000 microsecond range)

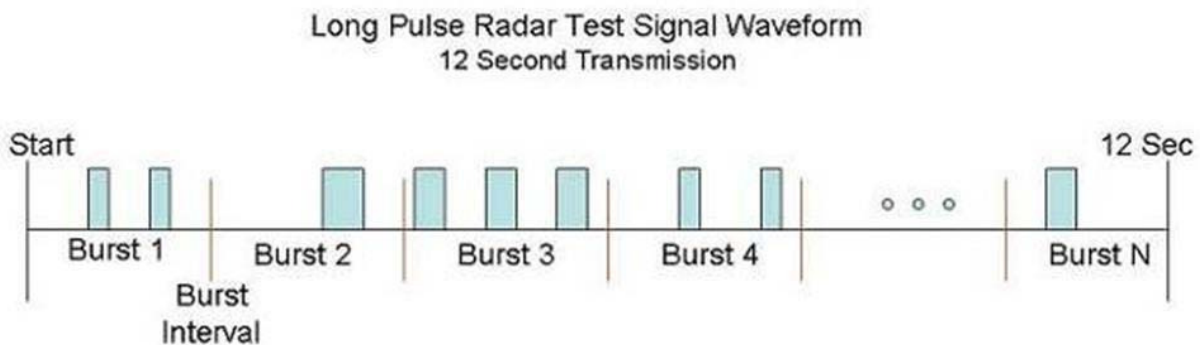

### 3. Frequency Hopping Radar Type

Radar Type	Pulse Width (μsec)	PRI (μsec)	Pulses per Hop	Hopping Rate (kHz)	Hopping Sequence Length (msec)	Minimum Percentage of Successful Detection	Minimum Trials
6	1	333	9	0.333	300	70%	30

Test Report No.	16040115-FCC-R3
Page	12 of 78

For the Frequency Hopping Radar Type, the same Burst parameters are used for each waveform. The hopping sequence is different for each waveform and a 100-length segment is selected 1 from the hopping sequence defined by the following algorithm:

The first frequency in a hopping sequence is selected randomly from the group of 475 integer frequencies from 5250 – 5724 MHz. Next, the frequency that was just chosen is removed from the group and a frequency is randomly selected from the remaining 474 frequencies in the group. This process continues until all 475 frequencies are chosen for the set. For selection of a random frequency, the frequencies remaining within the group are always treated as equally likely.

### **6.1.2 Radar Waveform Calibration**

The following equipment setup was used to calibrate the conducted Radar Waveform. A spectrum analyzer was used to establish the test signal level for each radar type. During this process there were no transmissions by either the Master or Client Device. The spectrum analyzer was switched to the zero span (Time Domain) mode at the frequency of the Radar Waveform generator. Peak detection was utilized. The spectrum analyzer resolution bandwidth (RBW) and video bandwidth (VBW) were set to 3 MHz.

For a detection threshold level of -62dBm and the Master antenna gain is -0.98 dBi for the band 5250-5350MHz, and -0.26 dBi for the band 5470-5725MHz., required detection threshold is -62.98dBi for the band 5250-5350MHz, and -62.26 dBi for the band 5470-5725MHz.

Note: Maximum Transmit Power is less than 200 milliwatt in this report, so detection threshold level is -62dBm

**Power and PSD**

Mode	Frequency	Power (dBm)	Gain	E.I.R.P	PSD(dBm/MHz)
802..11 a20	5320	8.58	0.98	9.56	-5.402
	5500	7.78	0.26	8.04	-3.452
802..11 n40	5310	7.86	0.98	8.84	-7.825
	5510	7.96	0.26	8.22	-7.259
802..11 ac80	5290	5.11	0.98	6.09	-13.878
	5530	5.21	0.26	5.47	-13.429

### Calibration Test Plots

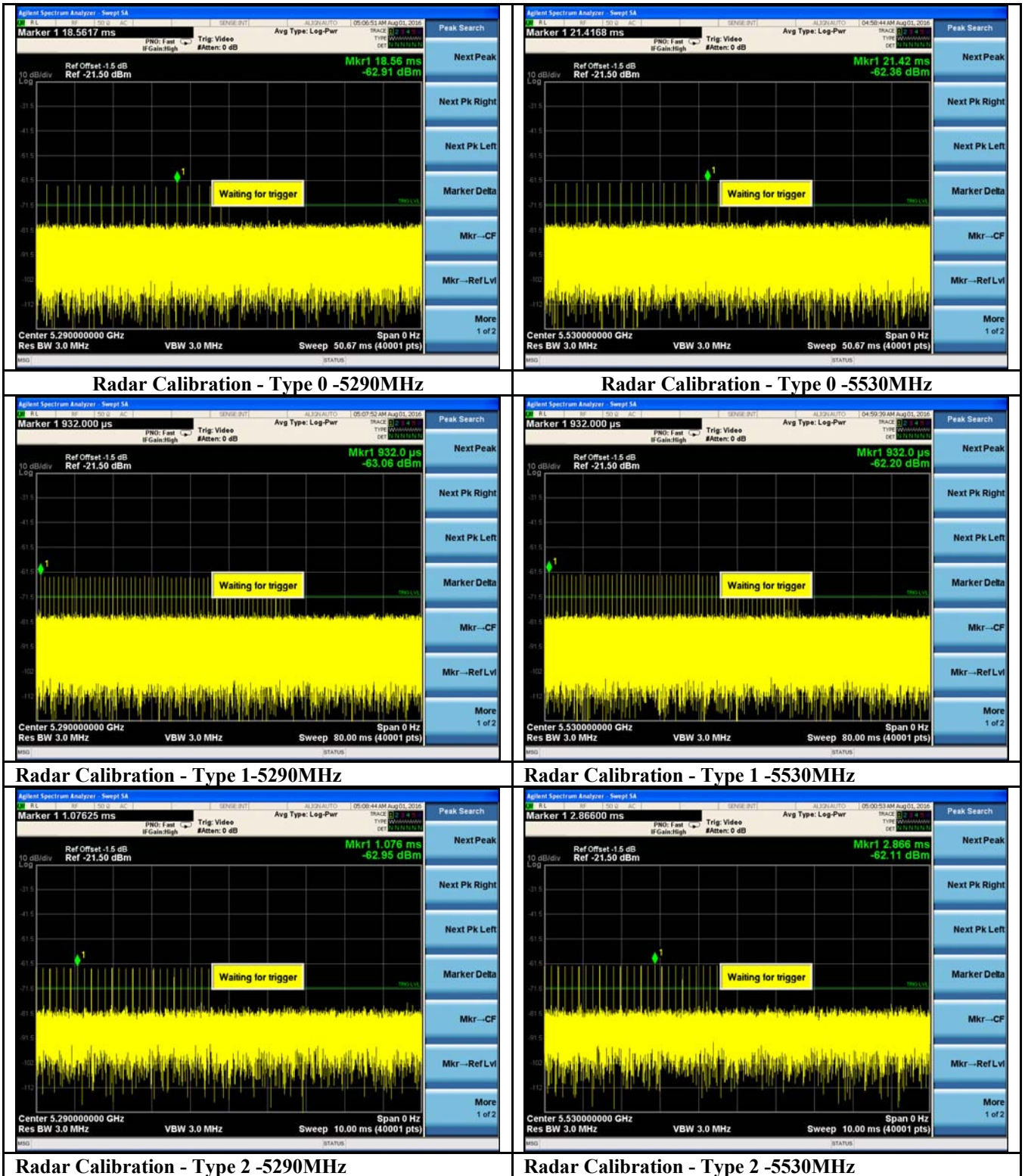

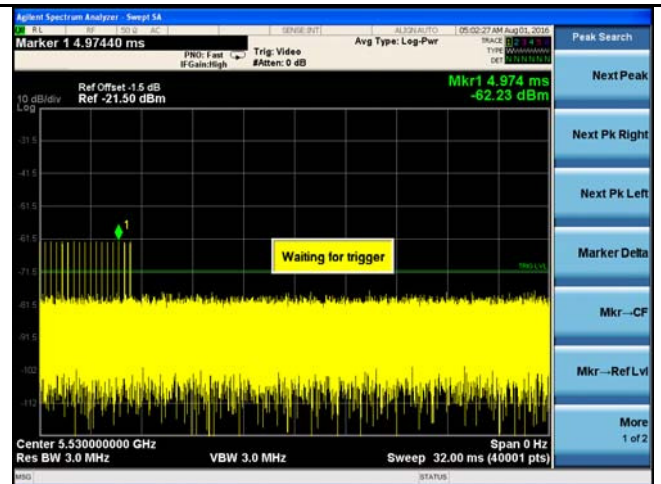
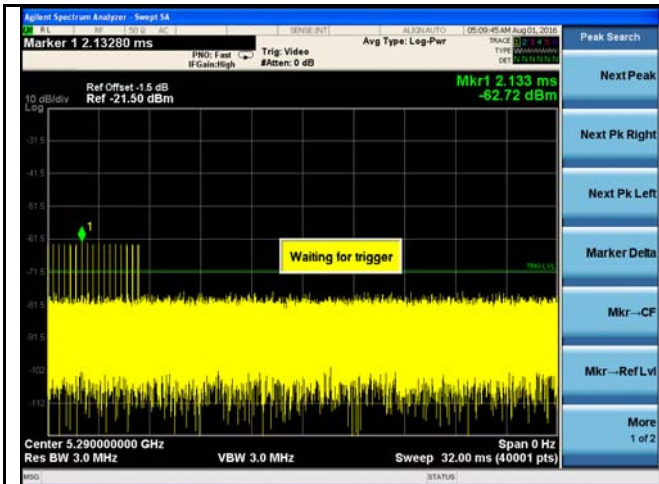

**Radar Calibration - Type 3 -5290MHz**

**Radar Calibration - Type 3 -5530MHz**

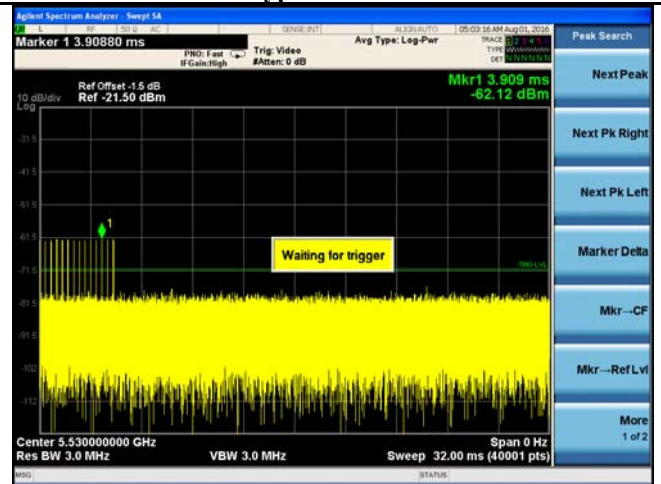
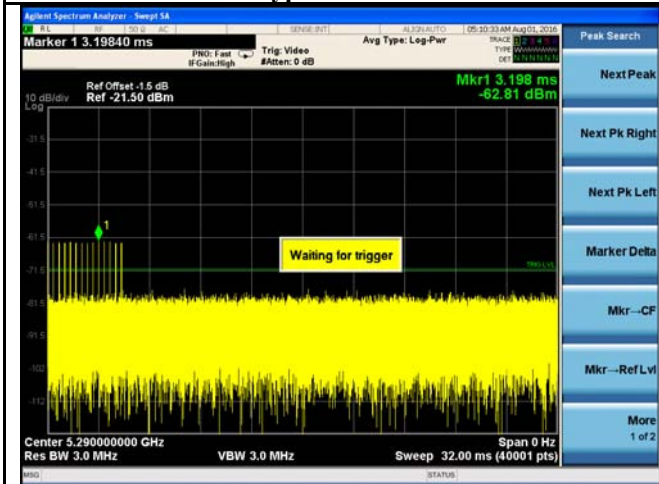

**Radar Calibration - Type 4 -5290MHz**

**Radar Calibration - Type 4 -5530MHz**

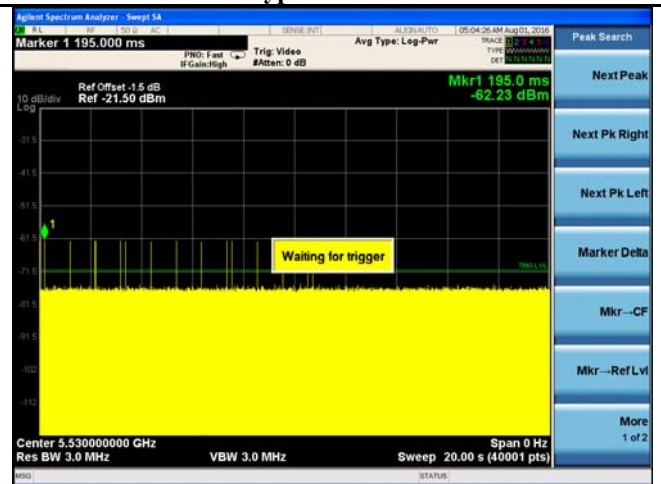
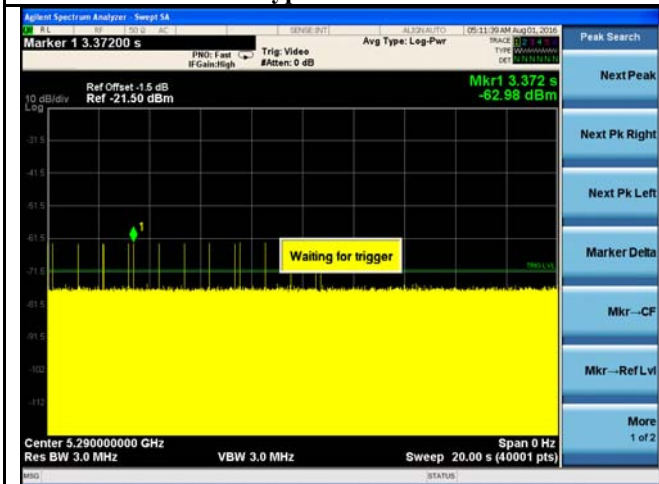

**Radar Calibration - Type 5 -5290MHz**

**Radar Calibration - Type 5 -5530MHz**

Test Report No.	16040115-FCC-R3
Page	16 of 78

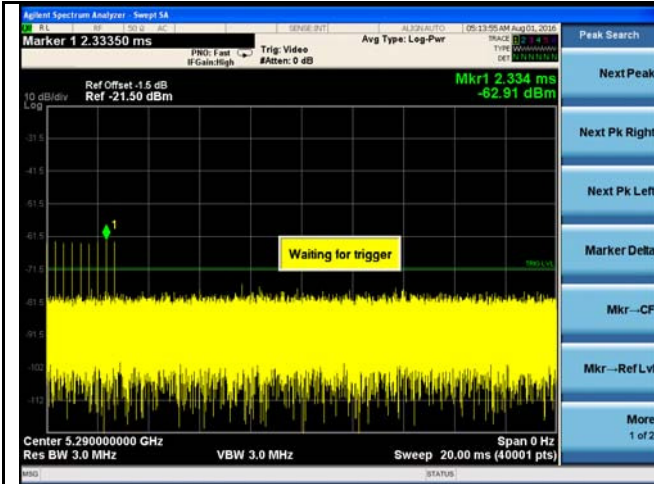

**Radar Calibration - Type 6 -5290MHz**

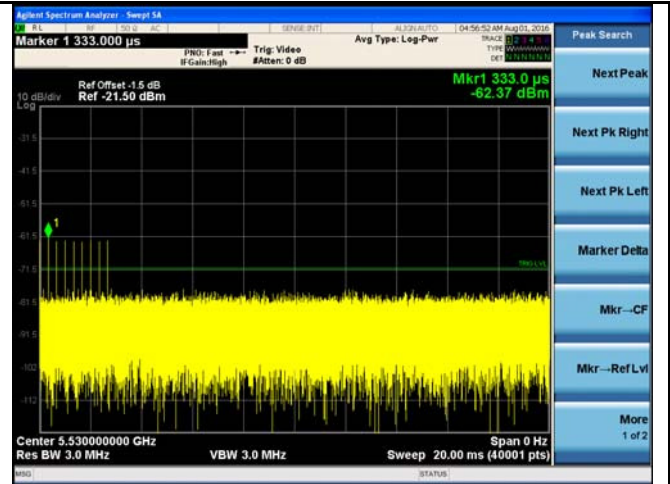

**Radar Calibration - Type 6 -5530MHz**

## **6.2 Test Procedure**

### **In-Service Monitoring for Channel Move Time, Channel Closing Transmission Time and Non-Occupancy Period**

These tests define how the following DFS parameters are verified during In-Service Monitoring; Channel Closing Transmission Time, Channel Move Time, and Non-Occupancy Period.

The steps below define the procedure to determine the above mentioned parameters when a radar Burst with a level equal to the DFS Detection Threshold + 1dB is generated on the Operating Channel of the U-NII device.

UUT operating as a Client Device will associate with the (Master) at Mid Channel. DFS testing while the System testing was performed with the designated MPEG test file that streams full motion video at 30 frames per second from the Master to the Client IP based system

At time T0 the Radar Waveform generator sends a Burst of pulses for each of the radar types.

Observe the transmissions of the UUT at the end of the radar Burst on the Operating Channel for duration greater than 10 seconds. Measure and record the transmissions from the UUT during the observation time (Channel Move Time). Compare the Channel Move Time and Channel Closing Transmission Time results to the limits defined in the DFS Response requirement values table.

### **Channel Closing Transmission Time- Measurement**

A type 1 waveform was introduced to the EUT and the Spectrum Analyzer sweep time was set to 1s for monitoring and capturing the plot. A LabView program was created to collect trace data and capturing the plot. The program will calculate the channel closing time base on the spectrum analyzer result. The result will be calculated based on FCC procedure.

$$C = N * Dwell$$

C is the closing time, N is the number of spectrum analyzer sampling bins showing a U-NII transmission and dwell is the dwell time per bin.

$$Dwell = S / B$$

Where Dwell is the dwell time per spectrum analyzer sampling bin, S is the sweep time and B is the number of spectrum analyzer sampling bins.

#### **10.1.4 DFS Test Setup**

Test Setup Block Diagram

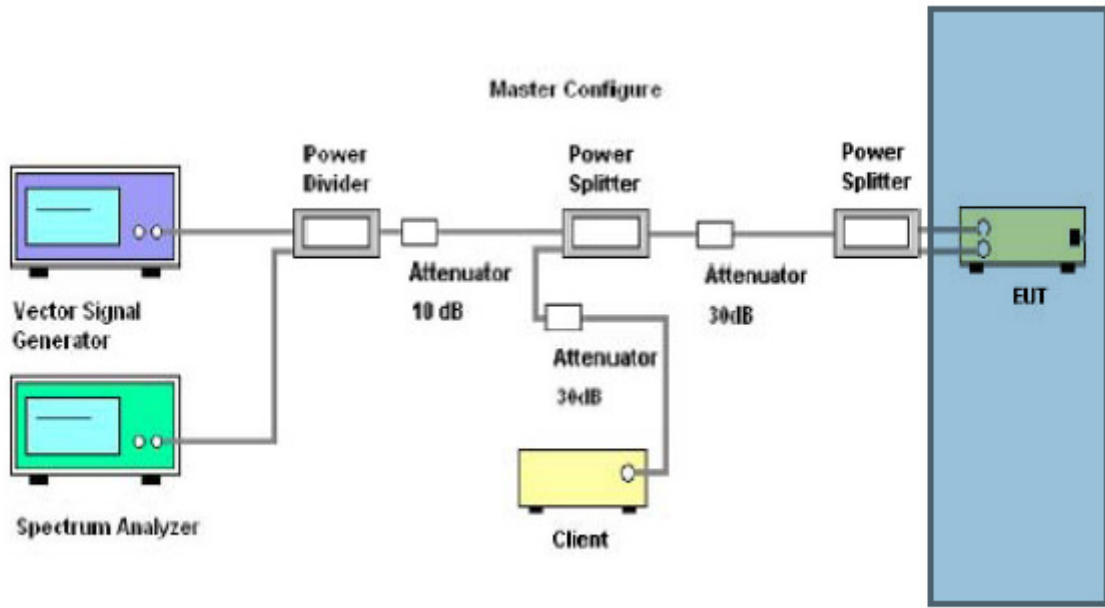

The radio was set at the center channel frequency of tested Channel.

A FCC approved Client device – (FCC ID: Q87-WUSB6300) USB wireless adapter was used to link with the UUT (master) device.

For the frequency bands 5250MHz to 5725MHz the master device provides, on aggregate, uniform loading of the spectrum across all devices by selecting an operating channel among the available channels using a random algorithm.

For a detection threshold level of -62dBm and the Master antenna gain is 0.98 dBi for the band 5250-5350MHz, and 0.26 dBi for the band 5470-5725MHz., required detection threshold is -62.98dBi for the band 5250-5350MHz, and - 61.26 dBi for the band 5470-5725MHz.

Note: Maximum Transmit Power is less than 200 milliwatt in this report, so detection threshold level is -62dBm

## **10.1.5 DFS Test Results**

### **10.1.5.1 UNII Detection Bandwidth**

#### **UNII Detection Bandwidth: All UNII channels for this device have identical Channel bandwidths and testing was performed on Mid Channel**

The generating equipment is configured as shown in the Conducted Test Setup above. A single Burst of the short pulse radar type 0 is produced at Mid Channel at a -63 dBm level. The UUT is set up as a standalone device (no associated Client and no traffic).

A single radar Burst is generated for a minimum of 10 trials, and the response of the UUT is noted. The UUT must detect the Radar Waveform 90% or more of the time.

Starting at the center frequency of the UUT operating Channel, increase the radar frequency in 5 MHz steps, repeating the above test sequence, until the detection rate falls below the U-NII Detection Bandwidth criterion specified. Repeat this measurement in 1MHz steps at frequencies 5 MHz below where the detection rate begins to fall. Record the highest frequency (denote as FH) at which detection is greater than or equal to the U-NII Detection Bandwidth criterion. Recording the detection rate at frequencies above FH is not required to demonstrate compliance.

Starting at the center frequency of the UUT operating Channel, decrease the radar frequency in 5 MHz steps, repeating the above test sequence, until the detection rate falls below the U-NII Detection Bandwidth criterion specified in Table 4. Repeat this measurement in 1MHz steps at frequencies 5 MHz above where the detection rate begins to fall. Record the lowest frequency (denote as FL) at which detection is greater than or equal to the U-NII Detection Bandwidth criterion. Recording the detection rate at frequencies below FL is not required to demonstrate compliance.

The U-NII Detection Bandwidth is calculated as follows:

$$\text{U-NII Detection Bandwidth} = \text{FH} - \text{FL}$$

The U-NII Detection Bandwidth must be at least 100% of the UUT transmitter 99% power, otherwise, the UUT does not comply with DFS requirements.

**99% bandwidth:**

Test mode	Freq (MHz)	99% Bandwidth (MHz)
820.11a	5320	16.3497
	5500	16.3306
802.11n (40M)	5310	36.0583
	5510	36.0996
802.11ac (80M)	5290	75.0992
	5530	74.8824

**a-20 mode:**

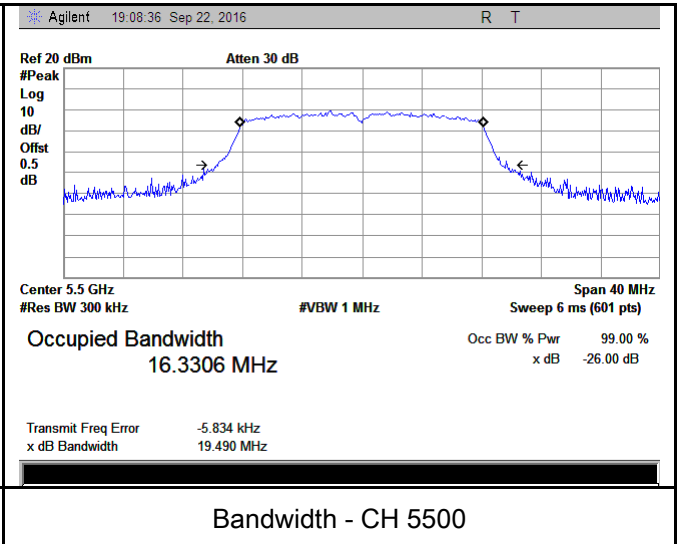
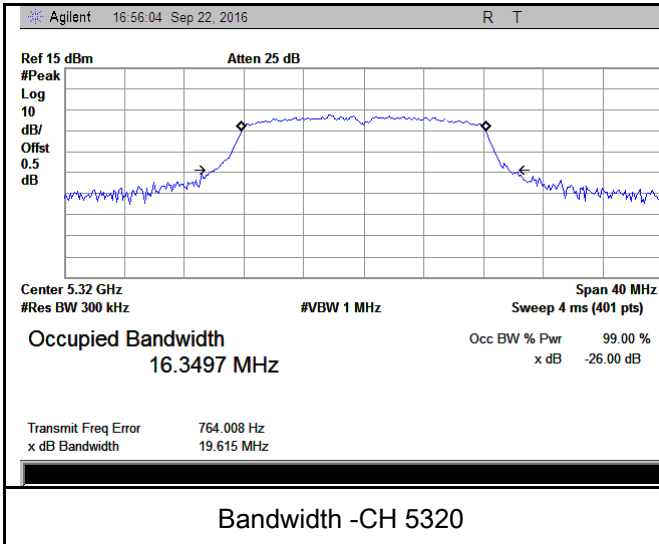

**n-40 mode:**

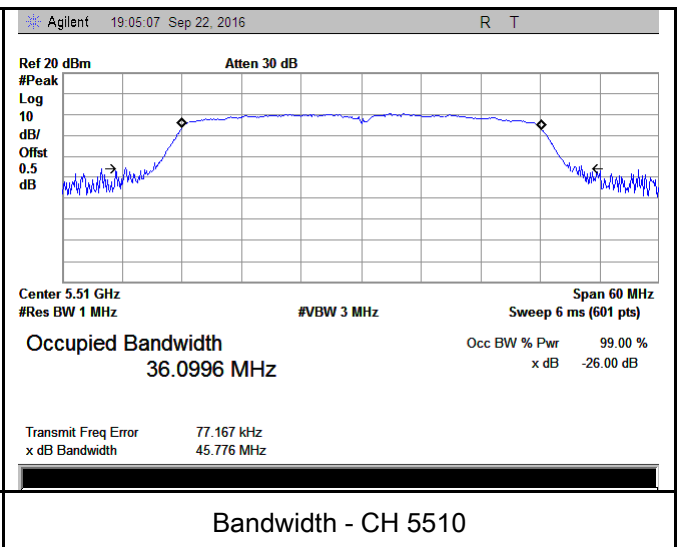
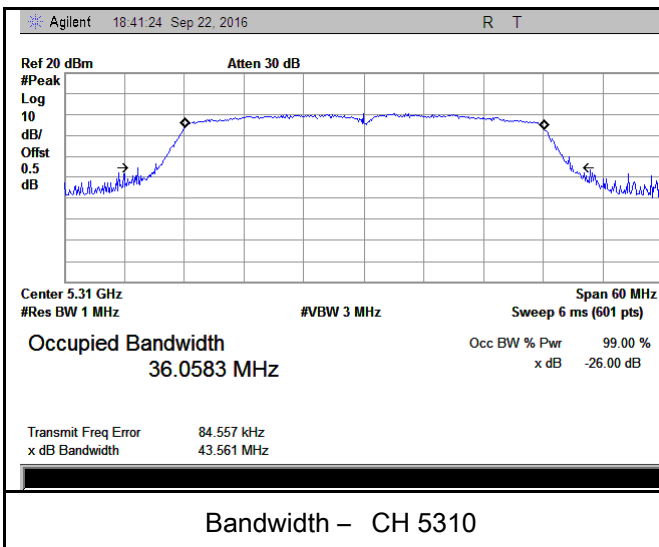

**ac-80 mode:**

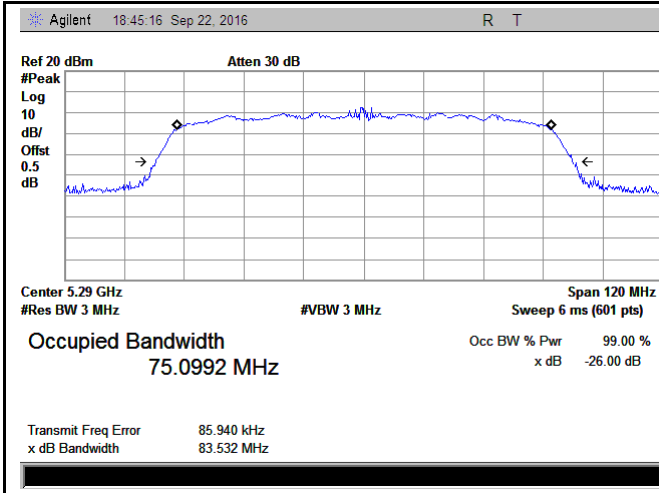

Bandwidth - CH 5290

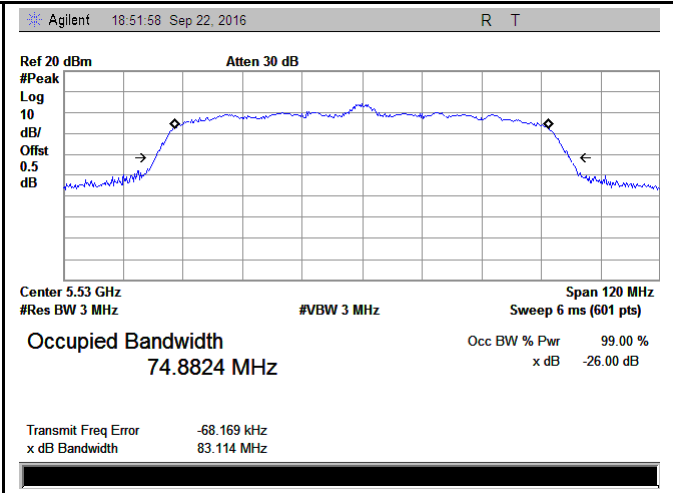

5Bandwidth - CH 5530

### Test result

#### EUT Frequency=5320MHz (20MH mode)

Frequency (MHz)	Trial 1	Trial 2	Trial 3	Trial 4	Trial 5	Trial 6	Trial 7	Trial 8	Trial 9	Trial 10	Detection Rate %
5309	No	No	No	No	No	No	No	No	No	No	0.00%
5310	Yes	Yes	Yes	Yes	Yes	Yes	Yes	Yes	Yes	Yes	100.00%
5315	Yes	Yes	Yes	Yes	Yes	Yes	Yes	Yes	Yes	Yes	100.00%
5320	Yes	Yes	Yes	Yes	Yes	Yes	Yes	Yes	Yes	Yes	100.00%
5325	Yes	Yes	Yes	Yes	Yes	Yes	Yes	No	Yes	Yes	90.00%
5330	Yes	Yes	Yes	Yes	Yes	Yes	Yes	Yes	Yes	Yes	100.00%
5331	No	No	No	No	No	No	No	No	No	No	0.00%
Detection Bandwidth: 20 MHz											
Specification: at least 100% of 99% of EUT bandwidth= 16.35 MHz											

#### EUT Frequency = 5500MHz (20MH mode)

Frequency (MHz)	Trial 1	Trial 2	Trial 3	Trial 4	Trial 5	Trial 6	Trial 7	Trial 8	Trial 9	Trial 10	Detection Rate %
5489	No	No	No	No	No	No	No	No	No	No	0.00%
5490	Yes	Yes	No	Yes	Yes	Yes	Yes	Yes	Yes	Yes	90.00%
5495	Yes	Yes	Yes	Yes	Yes	Yes	Yes	Yes	Yes	Yes	100.00%
5500	Yes	Yes	Yes	Yes	Yes	Yes	Yes	Yes	Yes	Yes	100.00%
5505	Yes	Yes	Yes	Yes	Yes	Yes	Yes	Yes	Yes	Yes	100.00%
5510	Yes	Yes	Yes	Yes	Yes	Yes	Yes	Yes	Yes	Yes	100.00%
5511	No	No	No	No	No	No	No	No	No	No	0.00%
Detection Bandwidth: 20 MHz											
Specification: at least 100% of 99% of EUT bandwidth= 16.33 MHz											

**EUT Frequency = 5310MHz (40MHz mode)**

Frequency (MHz)	Trial 1	Trial 2	Trial 3	Trial 4	Trial 5	Trial 6	Trial 7	Trial 8	Trial 9	Trial 10	Detection Rate %
5290	No	No	Yes	No	No	No	No	No	No	No	10.00%
5291	Yes	Yes	Yes	No	Yes	Yes	Yes	Yes	Yes	Yes	90.00%
5295	Yes	Yes	Yes	Yes	Yes	Yes	Yes	Yes	Yes	Yes	100.00%
5300	Yes	Yes	Yes	Yes	Yes	Yes	Yes	Yes	Yes	Yes	100.00%
5305	Yes	Yes	Yes	Yes	Yes	Yes	Yes	Yes	Yes	Yes	100.00%
5310	Yes	Yes	Yes	Yes	Yes	Yes	Yes	Yes	Yes	Yes	100.00%
5315	Yes	Yes	Yes	Yes	Yes	Yes	Yes	Yes	Yes	Yes	100.00%
5320	Yes	Yes	Yes	Yes	Yes	Yes	Yes	Yes	Yes	Yes	100.00%
5325	Yes	Yes	Yes	Yes	Yes	Yes	Yes	Yes	Yes	Yes	100.00%
5329	Yes	Yes	Yes	Yes	Yes	Yes	Yes	Yes	Yes	Yes	100.00%
5330	No	No	No	No	No	No	No	No	No	No	0.00%
Detection Bandwidth: 38 MHz											
Specification: at least 100% of 99% of EUT bandwidth= 36.06 MHz											

**EUT Frequency = 5510MHz (11n-40MHz mode)**

Frequency (MHz)	Trial 1	Trial 2	Trial 3	Trial 4	Trial 5	Trial 6	Trial 7	Trial 8	Trial 9	Trial 10	Detection Rate %
5490	No	No	No	Yes	No	No	No	No	No	No	10.00%
5491	Yes	Yes	Yes	Yes	Yes	Yes	Yes	Yes	Yes	Yes	100.00%
5495	Yes	Yes	Yes	Yes	Yes	Yes	Yes	Yes	Yes	Yes	100.00%
5500	Yes	Yes	Yes	Yes	Yes	Yes	Yes	Yes	Yes	Yes	100.00%
5505	Yes	Yes	Yes	Yes	Yes	Yes	Yes	Yes	Yes	Yes	100.00%
5510	Yes	Yes	Yes	Yes	Yes	Yes	Yes	Yes	Yes	Yes	100.00%
5515	Yes	Yes	Yes	Yes	Yes	Yes	Yes	Yes	Yes	Yes	100.00%
5520	Yes	Yes	Yes	Yes	Yes	Yes	Yes	Yes	Yes	Yes	100.00%
5525	Yes	Yes	Yes	Yes	Yes	Yes	Yes	Yes	Yes	Yes	100.00%
5529	Yes	Yes	Yes	Yes	Yes	Yes	Yes	Yes	Yes	Yes	100.00%
5530	No	No	No	No	Yes	Yes	No	No	Yes	No	30.00%
Detection Bandwidth: 38 MHz											
Specification: at least 100% of 99% of EUT bandwidth= 36.10 MHz											

**EUT Frequency = 5290MHz (80MHz mode)**

Frequency (MHz)	Trial 1	Trial 2	Trial 3	Trial 4	Trial 5	Trial 6	Trial 7	Trial 8	Trial 9	Trial 10	Detection Rate %
5249	No	No	No	Yes	No	No	No	No	No	No	10.00%
5250	Yes	Yes	Yes	Yes	Yes	Yes	Yes	Yes	Yes	Yes	100.00%
5255	Yes	Yes	Yes	Yes	Yes	Yes	Yes	Yes	Yes	Yes	100.00%
5260	Yes	Yes	Yes	Yes	Yes	No	Yes	Yes	Yes	Yes	90.00%
5265	Yes	Yes	Yes	Yes	Yes	Yes	Yes	Yes	Yes	Yes	100.00%
5270	Yes	Yes	Yes	Yes	Yes	Yes	Yes	Yes	Yes	Yes	100.00%
5275	Yes	Yes	Yes	Yes	Yes	Yes	Yes	Yes	Yes	Yes	100.00%
5280	Yes	Yes	Yes	Yes	Yes	Yes	Yes	Yes	Yes	Yes	100.00%
5285	Yes	Yes	NO	Yes	Yes	Yes	Yes	Yes	Yes	Yes	90.00%
5290	Yes	Yes	Yes	Yes	Yes	Yes	Yes	Yes	Yes	Yes	100.00%
5295	Yes	Yes	Yes	Yes	Yes	Yes	Yes	Yes	Yes	Yes	100.00%
5300	Yes	Yes	Yes	Yes	Yes	Yes	Yes	Yes	Yes	Yes	100.00%
5305	Yes	Yes	Yes	Yes	Yes	Yes	Yes	Yes	Yes	Yes	100.00%
5310	Yes	Yes	Yes	Yes	Yes	Yes	Yes	Yes	Yes	Yes	100.00%
5315	Yes	Yes	Yes	Yes	Yes	Yes	Yes	Yes	Yes	Yes	100.00%
5320	Yes	Yes	Yes	Yes	Yes	Yes	Yes	Yes	Yes	Yes	100.00%
5325	Yes	Yes	Yes	Yes	Yes	Yes	Yes	Yes	Yes	Yes	100.00%
5330	Yes	Yes	Yes	Yes	Yes	Yes	Yes	Yes	Yes	Yes	100.00%
5331	No	No	No	Yes	No	No	No	No	No	No	10.00%
Detection Bandwidth: 80MHz											
Specification: at least 100% of 99% of EUT bandwidth= 75.10 MHz											

**EUT Frequency = 5530MHz (80MHz mode)**

Frequency (MHz)	Trial 1	Trial 2	Trial 3	Trial 4	Trial 5	Trial 6	Trial 7	Trial 8	Trial 9	Trial 10	Detection Rate %
5249	No	No	No	Yes	No	No	No	No	No	No	10.00%
5250	Yes	Yes	Yes	Yes	Yes	Yes	Yes	Yes	Yes	Yes	100.00%
5255	Yes	Yes	Yes	Yes	Yes	Yes	Yes	Yes	Yes	Yes	100.00%
5260	Yes	Yes	Yes	Yes	Yes	No	Yes	Yes	Yes	Yes	90.00%
5265	Yes	Yes	Yes	Yes	Yes	Yes	Yes	Yes	Yes	Yes	100.00%
5270	Yes	Yes	Yes	Yes	Yes	Yes	Yes	Yes	Yes	Yes	100.00%
5275	Yes	Yes	Yes	Yes	Yes	Yes	Yes	Yes	Yes	Yes	100.00%
5280	Yes	Yes	Yes	Yes	Yes	Yes	Yes	Yes	Yes	Yes	100.00%
5285	Yes	Yes	Yes	Yes	Yes	Yes	Yes	Yes	Yes	Yes	100.00%
5290	Yes	Yes	Yes	Yes	Yes	Yes	Yes	Yes	Yes	Yes	100.00%
5295	Yes	Yes	Yes	Yes	Yes	Yes	Yes	Yes	Yes	Yes	100.00%
5300	Yes	Yes	Yes	Yes	Yes	Yes	Yes	Yes	Yes	Yes	100.00%
5305	Yes	Yes	Yes	Yes	Yes	Yes	Yes	No	Yes	Yes	90.00%
5310	Yes	Yes	Yes	Yes	Yes	Yes	Yes	Yes	Yes	Yes	100.00%
5315	Yes	Yes	Yes	Yes	Yes	Yes	Yes	Yes	Yes	Yes	100.00%
5320	Yes	Yes	Yes	Yes	Yes	Yes	Yes	Yes	Yes	Yes	100.00%
5325	Yes	Yes	Yes	Yes	Yes	Yes	Yes	Yes	Yes	Yes	100.00%
5330	Yes	Yes	Yes	Yes	Yes	Yes	Yes	Yes	Yes	Yes	100.00%
5331	No	No	No	Yes	No	No	No	No	No	No	10.00%
Detection Bandwidth: 80MHz											
Specification: at least 100% of 99% of EUT bandwidth= 74.88 MHz											

Test Report No.	16040115-FCC-R3
Page	26 of 78

### **6.3 Initial Channel Availability Check Time**

The Initial Channel Availability Check Time tests that the UUT does not emit beacon, control, or data signals on the test Channel until the power-up sequence has been completed and the U-NII device checks for Radar Waveforms for one minute on the test Channel. This test does not use any Radar Waveforms and only needs to be performed one time.

The U-NII device is powered on and be instructed to operate at Low channel, Mid Channel or High channel. At the same time the UUT is powered on, the spectrum analyzer is set to zero span modes with a 3 MHz resolution bandwidth at low, mid can high channel with a 2.5 minute sweep time. The analyzer's sweep will be started the same time power is applied to the UNII device.

The UUT should not transmit any beacon or data transmissions until at least 1 minute after the completion of the power-on cycle.

The initial power up time of the UUT is indicated by marker 1 in the plot. Initial beacons/data transmissions are indicated by marker.

**Test Plots**

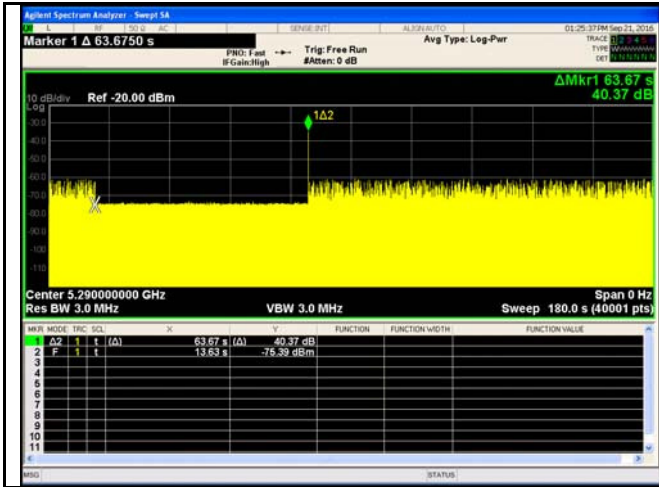

**Initial CAC – VHT80 – 5290MHz**

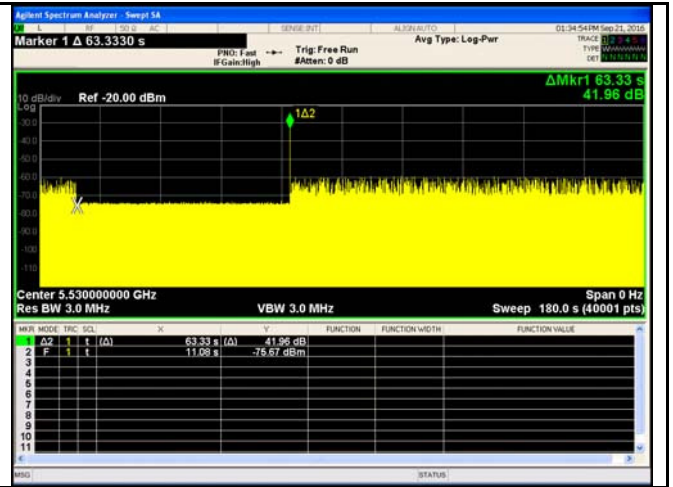

**Initial CAC – VHT80 – 5530MHz**

## **6.4 Radar Burst at the Beginning of the Channel Availability Check Time**

Radar Burst at the Beginning of the Channel Availability Check Time: The steps below define the procedure to verify successful radar detection on the selected Channel during a period equal to the Channel Availability Check Time and avoidance of operation on that Channel when a radar burst with a level equal to the DFS Detection Threshold + 1 dB occurs at the beginning of the Channel Availability Check Time.

The UUT is powered on at T0. T1 denotes the instant when the UUT has completed its power-up sequence. The Channel Availability Check Time commences at instant T1 and will end no sooner than T1 + 60 seconds. A single Burst of short pulse of radar type 1 at - 62 dBm will commence within a 6 second window.

Verify that during the 2.5 minute measurement window no UUT transmissions occurred at mid channel. Visual indication on the UUT of successful detection of the radar Burst will be recorded and reported.

Observation of emissions at center frequency of low channel, mid channel and high channel will continue for 2.5 minutes after the radar Burst has been generated.

**Note:**

**EUT power on cycle time  $\approx$  27 Sec**

**For CAC at the beginning, the radar signal was injected within 6 sec after 27 sec.**

**For CAC at the end, the radar signal was injected within 6 sec before 87 sec.**

**Test Plots**



**Radar at beginning of CAC – VHT80 – 5290MHz**



**Radar at beginning of CAC – VHT80 – 5530MHz**

## **6.5 Radar Burst at the End of the Channel Availability Check Time**

**Radar Burst at the End of the Channel Availability Check Time:** The steps below define the procedure to verify successful radar detection on the selected Channel during a period equal to the Channel Availability Check Time and avoidance of operation on that Channel when a radar Burst with a level equal to the DFS Detection Threshold + 1 dB occurs at the end of the Channel Availability Check Time.

The UUT is powered on at T0. T1 denotes the instant when the UUT has completed its power-up sequence. The Channel Availability Check Time commences at instant T1 and will end no sooner than T1 + 60 seconds.

A single Burst of short pulse of radar type 1 at -62 dBm will commence within a last 6 second window.

Visual indication on the UUT of successful detection of the radar Burst will be recorded and reported. Observation of emissions at center frequency of mid channel will continue for 2.5 minutes after the radar Burst has been generated.

Verify that during the 2.5 minute measurement window no UUT transmissions occurred at mid channel.

**Note:**

**EUT power on cycle time  $\approx$  27 Sec**

**For CAC at the beginning, the radar signal was injected within 6 sec after 27 sec.**

**For CAC at the end, the radar signal was injected within 6 sec before 87 sec.**

**Test Plots**

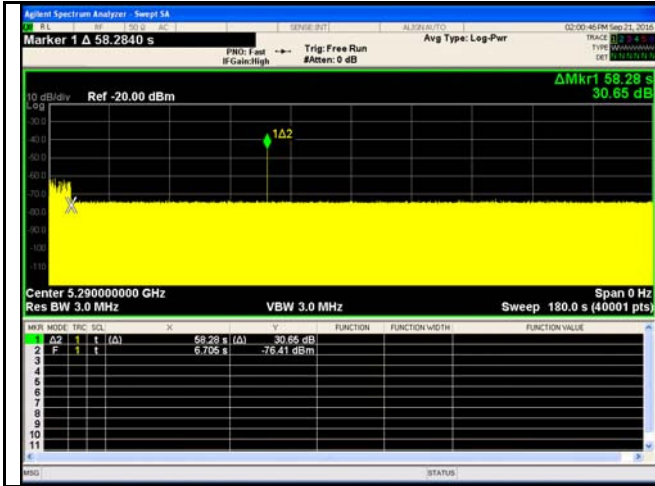

**Radar at end of CAC – VHT80 – 5290MHz**

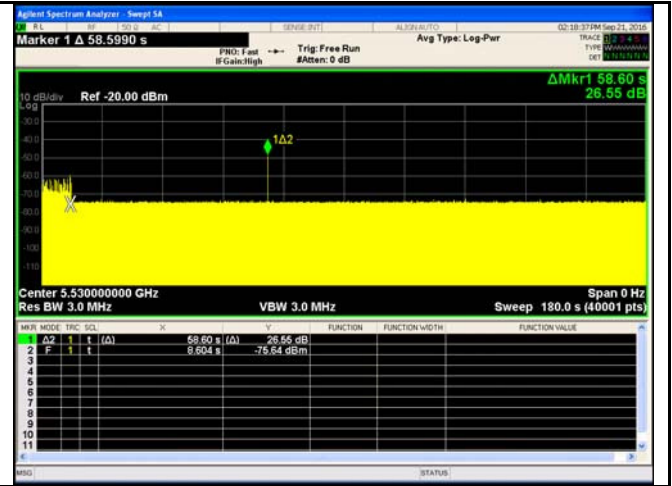

**Radar at end of CAC – VHT80 – 5530MHz**

## **6.6 In-Service Monitoring for Channel Move Time, Channel Closing Transmission Time and Non-Occupancy Period**

These tests define how the following DFS parameters are verified during In-Service Monitoring; Channel Closing Transmission Time, Channel Move Time, and Non-Occupancy Period.

The steps below define the procedure to determine the above mentioned parameters when a radar Burst with a level equal to the DFS Detection Threshold + 1dB is generated on the Operating Channel of the U-NII device.

A U-NII device operating as a Client Device will associate with the UUT (Master) at Mid Channel. Stream the MPEG test file from the Master Device to the Client Device on the selected Channel for the entire period of the test.

At time T0 the Radar Waveform generator sends a Burst of pulses for each of the radar types at -62dBm.

Observe the transmissions of the UUT at the end of the radar Burst on the Operating Channel for duration greater than 10 seconds. Measure and record the transmissions from the UUT during the observation time (Channel Move Time). Compare the Channel Move Time and Channel Closing Transmission Time results to the limits defined in the DFS Response requirement values table.

### **Channel Closing Transmission Time- Measurement**

A type 1 waveform was introduced to the EUT and the Spectrum Analyzer sweep time was set to 1s for monitoring and capturing the plot. A LabView program was created to collect trace data and capturing the plot. The program will calculate the channel closing time base on the spectrum analyzer result. The result will be calculated based on FCC procedure.

$$C = N * Dwell$$

C is the closing time, N is the number of spectrum analyzer sampling bins showing a U-NII transmission and dwell is the dwell time per bin.

$$Dwell = S / B$$

Where Dwell is the dwell time per spectrum analyzer sampling bin, S is the sweep time and B is the number of spectrum analyzer sampling bins.

**Test Plots**

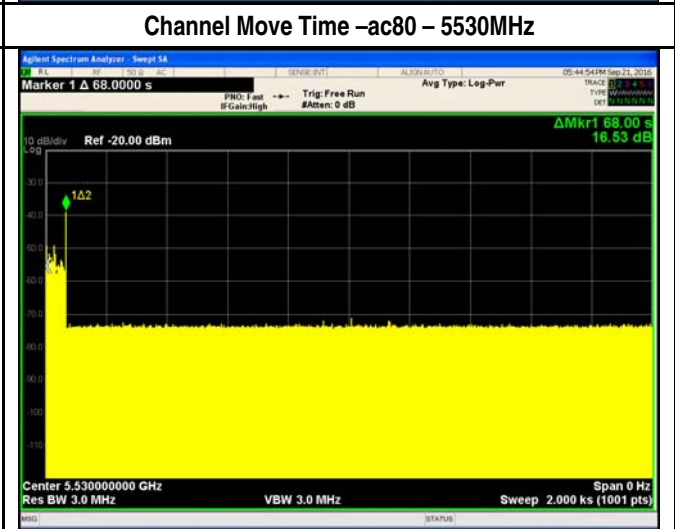
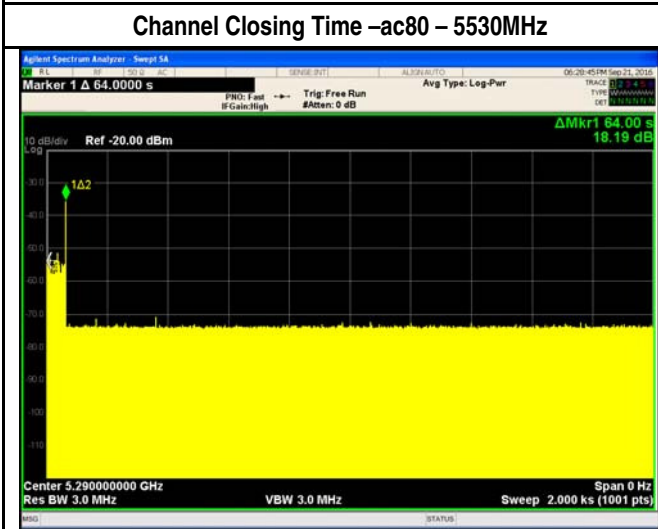
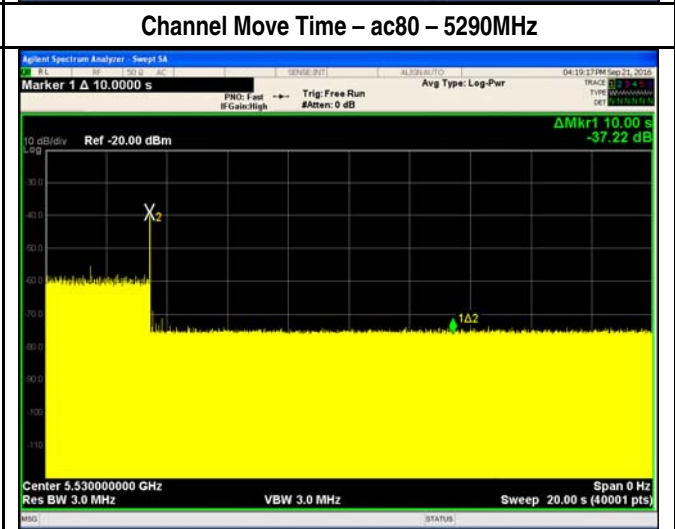
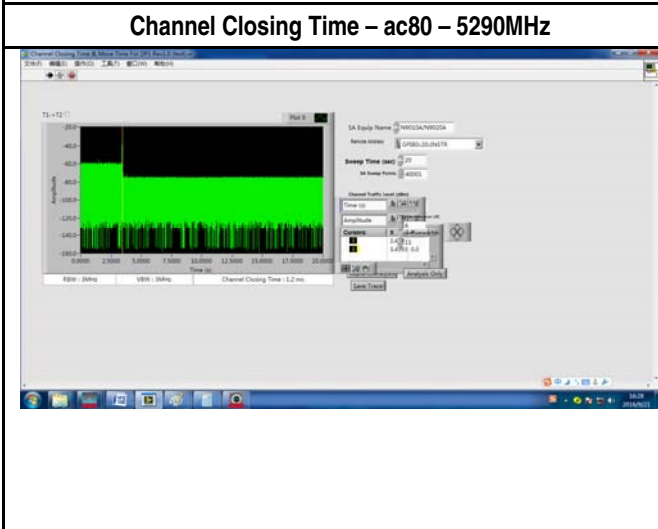
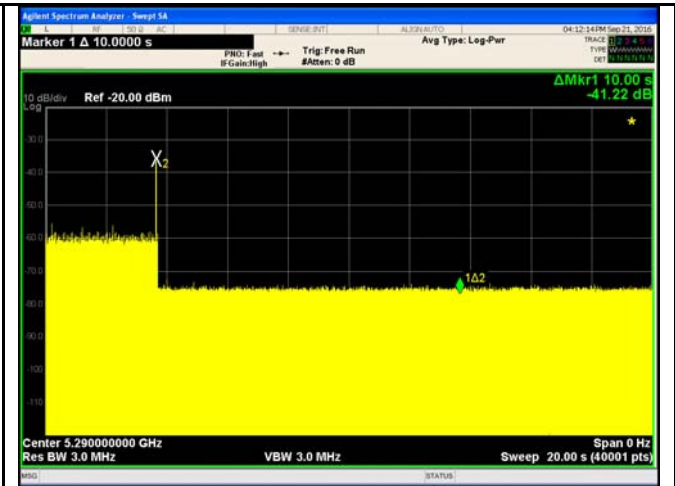
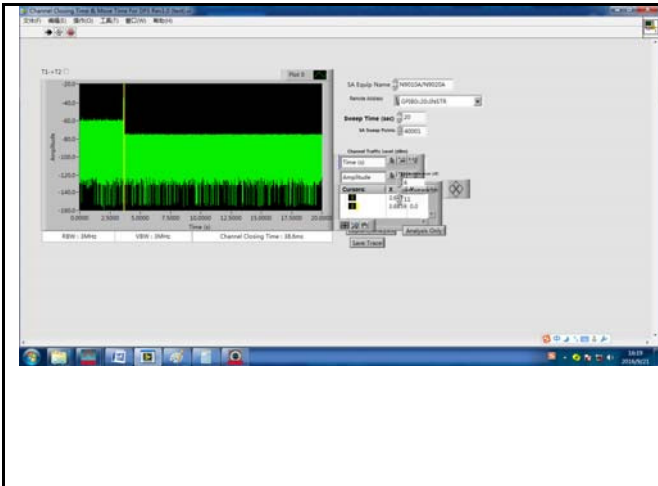

## **6.7 Statistical Performance Check**

Statistical Performance Check, the steps below define the procedure to determine the minimum percentage of detection when a radar burst with a level equal to the DFS Detection Threshold + 1dB is generated on the Operating Channel of the U-NII device.

A U-NII device operating as a Client Device will associate with the UUT (Master) at Low, Mid and High Channel. Stream the MPEG test file from the Master Device to the Client Device on the selected Channel for the entire period of the test.

The Radar Waveform generator sends the individual waveform for each of the radar types 0-6 at -62dbm. Statistical data will be gathered to determine the ability of the device to detect the radar test

$$\frac{\text{TotalWaveformDetections}}{\text{TotalWaveformTrials}} \times 100 = \text{Percentage of Successful Detection Radar Waveform } N = P_d N$$

The Minimum number of trails, minimum percentage of successful detection and the average minimum percentage of successful detection are found in the Radar Test Waveforms section.

**Summary:**

**Table 1: Short Pulse Radar Test Waveforms**

TX ( 20MHz mode)

Frequency (MHz)	Radar Type	Number of Trials	Number of Successful Detections	Minimum Percentage of Successful Detection	Limit	Result
5320	1	30	30	100%	60%	Pass
5320	2	30	30	100%	60%	Pass
5320	3	30	30	100%	60%	Pass
5320	4	30	30	100%	60%	Pass
5320	Aggregate (100.0% + 100.0% + 100.0% + 100.0%)/4 = 100.00%				100%	Pass

Frequency (MHz)	Radar Type	Number of Trials	Number of Successful Detections	Minimum Percentage of Successful Detection	Limit	Result
5500	1	30	30	100%	60%	Pass
5500	2	30	30	100%	60%	Pass
5500	3	30	30	100%	60%	Pass
5500	4	30	30	100%	60%	Pass
5500	Aggregate (100.0% + 100.00% + 100.00% + 100.00%)/4 =100.00%				100.00%	Pass

TX (40MHz mode)

Frequency (MHz)	Radar Type	Number of Trials	Number of Successful Detections	Minimum Percentage of Successful Detection	Limit	Result
5310	1	30	30	100%	60%	Pass
5310	2	30	30	100%	60%	Pass
5310	3	30	30	100%	60%	Pass
5310	4	30	27	90.0%	60%	Pass
5310	Aggregate (100.0% + 100.0% + 100.0% + 90.0%)/4 = 97.5%				80%	Pass

Frequency (MHz)	Radar Type	Number of Trials	Number of Successful Detections	Minimum Percentage of Successful Detection	Limit	Result
5510	1	30	30	100%	60%	Pass
5510	2	30	30	100%	60%	Pass
5510	3	30	30	100%	60%	Pass
5510	4	30	26	86.7%	60%	Pass
5510	Aggregate (100.0% + 100.0% + 100.0% + 86.67%)/4 = 96.67%				80%	Pass

TX (80MHz mode)

Frequency (MHz)	Radar Type	Number of Trials	Number of Successful Detections	Minimum Percentage of Successful Detection	Limit	Result
5290	1	30	30	100%	60%	Pass
5290	2	30	29	96.7%	60%	Pass
5290	3	30	30	100%	60%	Pass
5290	4	30	30	100%	60%	Pass
5290	Aggregate (10.0% + 73.3% + 0% + 0%)/4 = 99.18%				80%	Pass

Frequency (MHz)	Radar Type	Number of Trials	Number of Successful Detections	Minimum Percentage of Successful Detection	Limit	Result
5530	1	30	29	96.7%	60%	Pass
5530	2	30	28	93.33%	60%	Pass
5530	3	30	27	90.00%	60%	Pass
5530	4	30	29	96.67%	60%	Pass
5530	Aggregate (10.0% + 36.6% + 3.33% + 6.67%)/4 = 94.175%				80%	Pass

**Table 2: Short Pulse Radar Test Waveforms**

T X (20MHz mode)

Frequency (MHz)	Radar Type	Number of Trials	Number of Successful Detections	Minimum Percentage of Successful Detection	Limit	Result
5320	5	30	29	96.67%	80%	Pass

Frequency (MHz)	Radar Type	Number of Trials	Number of Successful Detections	Minimum Percentage of Successful Detection	Limit	Result
5500	5	30	29	96.67%	80%	Pass

T X (40MHz mode)

Frequency (MHz)	Radar Type	Number of Trials	Number of Successful Detections	Minimum Percentage of Successful Detection	Limit	Result
5310	5	30	29	96.67%	80%	Pass

Frequency (MHz)	Radar Type	Number of Trials	Number of Successful Detections	Minimum Percentage of Successful Detection	Limit	Result
5510	5	30	29	96.67%	80%	Pass

T X (80MHz mode)

Frequency (MHz)	Radar Type	Number of Trials	Number of Successful Detections	Minimum Percentage of Successful Detection	Limit	Result
5290	5	30	29	96.67%	80%	Pass

Frequency (MHz)	Radar Type	Number of Trials	Number of Successful Detections	Minimum Percentage of Successful Detection	Limit	Result
5530	5	30	30	100.00%	80%	Pass

**Table 3: Frequency Hopping Radar Test Waveform**

T X (20MHz mode)

Frequency (MHz)	Radar Type	Number of Trials	Number of Successful Detections	Minimum Percentage of Successful Detection	Limit	Result
5320	6	30	30	100.00%	70%	Pass

Frequency (MHz)	Radar Type	Number of Trials	Number of Successful Detections	Minimum Percentage of Successful Detection	Limit	Result
5500	6	30	30	100.00%	70%	Pass

T X (40MHz mode)

Frequency (MHz)	Radar Type	Number of Trials	Number of Successful Detections	Minimum Percentage of Successful Detection	Limit	Result
5310	6	30	30	100.00%	70%	Pass

Frequency (MHz)	Radar Type	Number of Trials	Number of Successful Detections	Minimum Percentage of Successful Detection	Limit	Result
5510	6	30	30	100.00%	70%	Pass

T X (80MHz mode)

Frequency (MHz)	Radar Type	Number of Trials	Number of Successful Detections	Minimum Percentage of Successful Detection	Limit	Result
5290	6	30	30	100.00%	70%	Pass

Frequency (MHz)	Radar Type	Number of Trials	Number of Successful Detections	Minimum Percentage of Successful Detection	Limit	Result
5530	6	30	30	100.00%	70%	Pass

### Test Result-5320MHz – 20MHz

Trials	Frequency (MHz)	Radar Type	Waveform Type	Status	Result
1	5300	FCC Radar Type 1	Waveform 1	Completed	Yes
2	5300	FCC Radar Type 1	Waveform 2	Completed	Yes
3	5300	FCC Radar Type 1	Waveform 3	Completed	Yes
4	5300	FCC Radar Type 1	Waveform 4	Completed	Yes
5	5300	FCC Radar Type 1	Waveform 5	Completed	Yes
6	5300	FCC Radar Type 1	Waveform 6	Completed	Yes
7	5300	FCC Radar Type 1	Waveform 7	Completed	Yes
8	5300	FCC Radar Type 1	Waveform 8	Completed	Yes
9	5300	FCC Radar Type 1	Waveform 9	Completed	Yes
10	5300	FCC Radar Type 1	Waveform 10	Completed	Yes
11	5300	FCC Radar Type 1	Waveform 11	Completed	Yes
12	5300	FCC Radar Type 1	Waveform 12	Completed	Yes
13	5300	FCC Radar Type 1	Waveform 13	Completed	Yes
14	5300	FCC Radar Type 1	Waveform 14	Completed	Yes
15	5300	FCC Radar Type 1	Waveform 15	Completed	Yes
16	5300	FCC Radar Type 1	Waveform 16	Completed	Yes
17	5300	FCC Radar Type 1	Waveform 17	Completed	Yes
18	5300	FCC Radar Type 1	Waveform 18	Completed	Yes
19	5300	FCC Radar Type 1	Waveform 19	Completed	Yes
20	5300	FCC Radar Type 1	Waveform 20	Completed	Yes
21	5300	FCC Radar Type 1	Waveform 21	Completed	Yes
22	5300	FCC Radar Type 1	Waveform 22	Completed	Yes
23	5300	FCC Radar Type 1	Waveform 23	Completed	Yes
24	5300	FCC Radar Type 1	Waveform 24	Completed	Yes
25	5300	FCC Radar Type 1	Waveform 25	Completed	Yes
26	5300	FCC Radar Type 1	Waveform 26	Completed	Yes
27	5300	FCC Radar Type 1	Waveform 27	Completed	Yes
28	5300	FCC Radar Type 1	Waveform 28	Completed	Yes
29	5300	FCC Radar Type 1	Waveform 29	Completed	Yes
30	5300	FCC Radar Type 1	Waveform 30	Completed	Yes

Detection Probability Rate %: 100.00

### Test Result-5320MHz – 20MHz

Trials	Frequency (MHz)	Radar Type	Waveform Type	Status	Result
1	5300	FCC Radar Type 2	Waveform 1	Completed	Yes
2	5300	FCC Radar Type 2	Waveform 2	Completed	Yes
3	5300	FCC Radar Type 2	Waveform 3	Completed	Yes
4	5300	FCC Radar Type 2	Waveform 4	Completed	Yes
5	5300	FCC Radar Type 2	Waveform 5	Completed	Yes
6	5300	FCC Radar Type 2	Waveform 6	Completed	Yes
7	5300	FCC Radar Type 2	Waveform 7	Completed	Yes
8	5300	FCC Radar Type 2	Waveform 8	Completed	Yes
9	5300	FCC Radar Type 2	Waveform 9	Completed	Yes
10	5300	FCC Radar Type 2	Waveform 10	Completed	Yes
11	5300	FCC Radar Type 2	Waveform 11	Completed	Yes
12	5300	FCC Radar Type 2	Waveform 12	Completed	Yes
13	5300	FCC Radar Type 2	Waveform 13	Completed	Yes
14	5300	FCC Radar Type 2	Waveform 14	Completed	Yes
15	5300	FCC Radar Type 2	Waveform 15	Completed	Yes
16	5300	FCC Radar Type 2	Waveform 16	Completed	Yes
17	5300	FCC Radar Type 2	Waveform 17	Completed	Yes
18	5300	FCC Radar Type 2	Waveform 18	Completed	Yes
19	5300	FCC Radar Type 2	Waveform 19	Completed	Yes
20	5300	FCC Radar Type 2	Waveform 20	Completed	Yes
21	5300	FCC Radar Type 2	Waveform 21	Completed	Yes
22	5300	FCC Radar Type 2	Waveform 22	Completed	Yes
23	5300	FCC Radar Type 2	Waveform 23	Completed	Yes
24	5300	FCC Radar Type 2	Waveform 24	Completed	Yes
25	5300	FCC Radar Type 2	Waveform 25	Completed	Yes
26	5300	FCC Radar Type 2	Waveform 26	Completed	Yes
27	5300	FCC Radar Type 2	Waveform 27	Completed	Yes
28	5300	FCC Radar Type 2	Waveform 28	Completed	Yes
29	5300	FCC Radar Type 2	Waveform 29	Completed	Yes
30	5300	FCC Radar Type 2	Waveform 30	Completed	Yes
Detection Probability Rate %:					100.00

### Test Result-5320MHz – 20MHz

Trials	Frequency (MHz)	Radar Type	Waveform Type	Status	Result
1	5300	FCC Radar Type 3	Waveform 1	Completed	Yes
2	5300	FCC Radar Type 3	Waveform 2	Completed	Yes
3	5300	FCC Radar Type 3	Waveform 3	Completed	Yes
4	5300	FCC Radar Type 3	Waveform 4	Completed	Yes
5	5300	FCC Radar Type 3	Waveform 5	Completed	Yes
6	5300	FCC Radar Type 3	Waveform 6	Completed	Yes
7	5300	FCC Radar Type 3	Waveform 7	Completed	Yes
8	5300	FCC Radar Type 3	Waveform 8	Completed	Yes
9	5300	FCC Radar Type 3	Waveform 9	Completed	Yes
10	5300	FCC Radar Type 3	Waveform 10	Completed	Yes
11	5300	FCC Radar Type 3	Waveform 11	Completed	Yes
12	5300	FCC Radar Type 3	Waveform 12	Completed	Yes
13	5300	FCC Radar Type 3	Waveform 13	Completed	Yes
14	5300	FCC Radar Type 3	Waveform 14	Completed	Yes
15	5300	FCC Radar Type 3	Waveform 15	Completed	Yes
16	5300	FCC Radar Type 3	Waveform 16	Completed	Yes
17	5300	FCC Radar Type 3	Waveform 17	Completed	Yes
18	5300	FCC Radar Type 3	Waveform 18	Completed	Yes
19	5300	FCC Radar Type 3	Waveform 19	Completed	Yes
20	5300	FCC Radar Type 3	Waveform 20	Completed	Yes
21	5300	FCC Radar Type 3	Waveform 21	Completed	Yes
22	5300	FCC Radar Type 3	Waveform 22	Completed	Yes
23	5300	FCC Radar Type 3	Waveform 23	Completed	Yes
24	5300	FCC Radar Type 3	Waveform 24	Completed	Yes
25	5300	FCC Radar Type 3	Waveform 25	Completed	Yes
26	5300	FCC Radar Type 3	Waveform 26	Completed	Yes
27	5300	FCC Radar Type 3	Waveform 27	Completed	Yes
28	5300	FCC Radar Type 3	Waveform 28	Completed	Yes
29	5300	FCC Radar Type 3	Waveform 29	Completed	Yes
30	5300	FCC Radar Type 3	Waveform 30	Completed	Yes

Detection Probability Rate %: 100.00

### Test Result-5320MHz – 20MHz

Trials	Frequency (MHz)	Radar Type	Waveform Type	Status	Result
1	5300	FCC Radar Type 4	Waveform 1	Completed	Yes
2	5300	FCC Radar Type 4	Waveform 2	Completed	Yes
3	5300	FCC Radar Type 4	Waveform 3	Completed	Yes
4	5300	FCC Radar Type 4	Waveform 4	Completed	Yes
5	5300	FCC Radar Type 4	Waveform 5	Completed	Yes
6	5300	FCC Radar Type 4	Waveform 6	Completed	Yes
7	5300	FCC Radar Type 4	Waveform 7	Completed	Yes
8	5300	FCC Radar Type 4	Waveform 8	Completed	Yes
9	5300	FCC Radar Type 4	Waveform 9	Completed	Yes
10	5300	FCC Radar Type 4	Waveform 10	Completed	Yes
11	5300	FCC Radar Type 4	Waveform 11	Completed	Yes
12	5300	FCC Radar Type 4	Waveform 12	Completed	Yes
13	5300	FCC Radar Type 4	Waveform 13	Completed	Yes
14	5300	FCC Radar Type 4	Waveform 14	Completed	Yes
15	5300	FCC Radar Type 4	Waveform 15	Completed	Yes
16	5300	FCC Radar Type 4	Waveform 16	Completed	Yes
17	5300	FCC Radar Type 4	Waveform 17	Completed	Yes
18	5300	FCC Radar Type 4	Waveform 18	Completed	Yes
19	5300	FCC Radar Type 4	Waveform 19	Completed	Yes
20	5300	FCC Radar Type 4	Waveform 20	Completed	Yes
21	5300	FCC Radar Type 4	Waveform 21	Completed	Yes
22	5300	FCC Radar Type 4	Waveform 22	Completed	Yes
23	5300	FCC Radar Type 4	Waveform 23	Completed	Yes
24	5300	FCC Radar Type 4	Waveform 24	Completed	Yes
25	5300	FCC Radar Type 4	Waveform 25	Completed	Yes
26	5300	FCC Radar Type 4	Waveform 26	Completed	Yes
27	5300	FCC Radar Type 4	Waveform 27	Completed	Yes
28	5300	FCC Radar Type 4	Waveform 28	Completed	Yes
29	5300	FCC Radar Type 4	Waveform 29	Completed	Yes
30	5300	FCC Radar Type 4	Waveform 30	Completed	Yes
Detection Probability Rate %:					100.00

### Test Result-5320MHz – 20MHz

Trials	Frequency (MHz)	Radar Type	Waveform Type	Status	Result
1	5322	FCC Radar Type 5	Waveform 1	Completed	Yes
2	5324	FCC Radar Type 5	Waveform 2	Completed	Yes
3	5327	FCC Radar Type 5	Waveform 3	Completed	Yes
4	5320	FCC Radar Type 5	Waveform 4	Completed	Yes
5	5321	FCC Radar Type 5	Waveform 5	Completed	Yes
6	5323	FCC Radar Type 5	Waveform 6	Completed	Yes
7	5320	FCC Radar Type 5	Waveform 7	Completed	Yes
8	5321	FCC Radar Type 5	Waveform 8	Completed	Yes
9	5322	FCC Radar Type 5	Waveform 9	Completed	Yes
10	5321	FCC Radar Type 5	Waveform 10	Completed	Yes
11	5321	FCC Radar Type 5	Waveform 11	Completed	Yes
12	5326	FCC Radar Type 5	Waveform 12	Completed	Yes
13	5327	FCC Radar Type 5	Waveform 13	Completed	Yes
14	5321	FCC Radar Type 5	Waveform 14	Completed	Yes
15	5325	FCC Radar Type 5	Waveform 15	Completed	Yes
16	5317	FCC Radar Type 5	Waveform 16	Completed	Yes
17	5318	FCC Radar Type 5	Waveform 17	Completed	Yes
18	5313	FCC Radar Type 5	Waveform 18	Completed	Yes
19	5319	FCC Radar Type 5	Waveform 19	Completed	Yes
20	5320	FCC Radar Type 5	Waveform 20	Completed	Yes
21	5317	FCC Radar Type 5	Waveform 21	Completed	Yes
22	5315	FCC Radar Type 5	Waveform 22	Completed	Yes
23	5316	FCC Radar Type 5	Waveform 23	Completed	Yes
24	5317	FCC Radar Type 5	Waveform 24	Completed	Yes
25	5313	FCC Radar Type 5	Waveform 25	Completed	Yes
26	5317	FCC Radar Type 5	Waveform 26	Completed	Yes
27	5315	FCC Radar Type 5	Waveform 27	Completed	Yes
28	5317	FCC Radar Type 5	Waveform 28	Completed	Yes
29	5313	FCC Radar Type 5	Waveform 29	Completed	No
30	5317	FCC Radar Type 5	Waveform 30	Completed	Yes

Occupied BW: 17.741MHz, 80%\*17.741=14.192MHz, The frequency range from 5293MHz to 5307MHz

Detection Probability Rate %: 96.67

**Note:** Per 905462 D02 UNII DFS Compliance Procedures New Rules v01r02. The center frequency for each of the 30 trials of the Bin 5 radar shall be randomly selected within 80% of the Occupied Bandwidth.

### Test Result-5320MHz – 20MHz

Trials	Frequency (MHz)	Radar Type	Waveform Type	Status	Result
1	5300	FCC Radar Type 6	Waveform 1	Completed	Yes
2	5300	FCC Radar Type 6	Waveform 2	Completed	Yes
3	5300	FCC Radar Type 6	Waveform 3	Completed	Yes
4	5300	FCC Radar Type 6	Waveform 4	Completed	Yes
5	5300	FCC Radar Type 6	Waveform 5	Completed	Yes
6	5300	FCC Radar Type 6	Waveform 6	Completed	Yes
7	5300	FCC Radar Type 6	Waveform 7	Completed	Yes
8	5300	FCC Radar Type 6	Waveform 8	Completed	Yes
9	5300	FCC Radar Type 6	Waveform 9	Completed	Yes
10	5300	FCC Radar Type 6	Waveform 10	Completed	Yes
11	5300	FCC Radar Type 6	Waveform 11	Completed	Yes
12	5300	FCC Radar Type 6	Waveform 12	Completed	Yes
13	5300	FCC Radar Type 6	Waveform 13	Completed	Yes
14	5300	FCC Radar Type 6	Waveform 14	Completed	Yes
15	5300	FCC Radar Type 6	Waveform 15	Completed	Yes
16	5300	FCC Radar Type 6	Waveform 16	Completed	Yes
17	5300	FCC Radar Type 6	Waveform 17	Completed	Yes
18	5300	FCC Radar Type 6	Waveform 18	Completed	Yes
19	5300	FCC Radar Type 6	Waveform 19	Completed	Yes
20	5300	FCC Radar Type 6	Waveform 20	Completed	Yes
21	5300	FCC Radar Type 6	Waveform 21	Completed	Yes
22	5300	FCC Radar Type 6	Waveform 22	Completed	Yes
23	5300	FCC Radar Type 6	Waveform 23	Completed	Yes
24	5300	FCC Radar Type 6	Waveform 24	Completed	Yes
25	5300	FCC Radar Type 6	Waveform 25	Completed	Yes
26	5300	FCC Radar Type 6	Waveform 26	Completed	Yes
27	5300	FCC Radar Type 6	Waveform 27	Completed	Yes
28	5300	FCC Radar Type 6	Waveform 28	Completed	Yes
29	5300	FCC Radar Type 6	Waveform 29	Completed	Yes
30	5300	FCC Radar Type 6	Waveform 30	Completed	Yes

Detection Probability Rate %: 100.00

### Test Result-5500MHz – 20MHz

Trials	Frequency (MHz)	Radar Type	Waveform Type	Status	Result
1	5500	FCC Radar Type 1	Waveform 1	Completed	Yes
2	5500	FCC Radar Type 1	Waveform 2	Completed	Yes
3	5500	FCC Radar Type 1	Waveform 3	Completed	Yes
4	5500	FCC Radar Type 1	Waveform 4	Completed	Yes
5	5500	FCC Radar Type 1	Waveform 5	Completed	Yes
6	5500	FCC Radar Type 1	Waveform 6	Completed	Yes
7	5500	FCC Radar Type 1	Waveform 7	Completed	Yes
8	5500	FCC Radar Type 1	Waveform 8	Completed	Yes
9	5500	FCC Radar Type 1	Waveform 9	Completed	Yes
10	5500	FCC Radar Type 1	Waveform 10	Completed	Yes
11	5500	FCC Radar Type 1	Waveform 11	Completed	Yes
12	5500	FCC Radar Type 1	Waveform 12	Completed	Yes
13	5500	FCC Radar Type 1	Waveform 13	Completed	Yes
14	5500	FCC Radar Type 1	Waveform 14	Completed	Yes
15	5500	FCC Radar Type 1	Waveform 15	Completed	Yes
16	5500	FCC Radar Type 1	Waveform 16	Completed	Yes
17	5500	FCC Radar Type 1	Waveform 17	Completed	Yes
18	5500	FCC Radar Type 1	Waveform 18	Completed	Yes
19	5500	FCC Radar Type 1	Waveform 19	Completed	Yes
20	5500	FCC Radar Type 1	Waveform 20	Completed	Yes
21	5500	FCC Radar Type 1	Waveform 21	Completed	Yes
22	5500	FCC Radar Type 1	Waveform 22	Completed	Yes
23	5500	FCC Radar Type 1	Waveform 23	Completed	Yes
24	5500	FCC Radar Type 1	Waveform 24	Completed	Yes
25	5500	FCC Radar Type 1	Waveform 25	Completed	Yes
26	5500	FCC Radar Type 1	Waveform 26	Completed	Yes
27	5500	FCC Radar Type 1	Waveform 27	Completed	Yes
28	5500	FCC Radar Type 1	Waveform 28	Completed	Yes
29	5500	FCC Radar Type 1	Waveform 29	Completed	Yes
30	5500	FCC Radar Type 1	Waveform 30	Completed	Yes
Detection Probability Rate %: 100.00					

### Test Result-5500MHz – 20MHz

Trial	Frequency (MHz)	Radar Type	Waveform Type	Status	Result
1	5500	FCC Radar Type 2	Waveform 1	Completed	Yes
2	5500	FCC Radar Type 2	Waveform 2	Completed	Yes
3	5500	FCC Radar Type 2	Waveform 3	Completed	Yes
4	5500	FCC Radar Type 2	Waveform 4	Completed	Yes
5	5500	FCC Radar Type 2	Waveform 5	Completed	Yes
6	5500	FCC Radar Type 2	Waveform 6	Completed	Yes
7	5500	FCC Radar Type 2	Waveform 7	Completed	Yes
8	5500	FCC Radar Type 2	Waveform 8	Completed	Yes
9	5500	FCC Radar Type 2	Waveform 9	Completed	Yes
10	5500	FCC Radar Type 2	Waveform 10	Completed	Yes
11	5500	FCC Radar Type 2	Waveform 11	Completed	Yes
12	5500	FCC Radar Type 2	Waveform 12	Completed	Yes
13	5500	FCC Radar Type 2	Waveform 13	Completed	Yes
14	5500	FCC Radar Type 2	Waveform 14	Completed	Yes
15	5500	FCC Radar Type 2	Waveform 15	Completed	Yes
16	5500	FCC Radar Type 2	Waveform 16	Completed	Yes
17	5500	FCC Radar Type 2	Waveform 17	Completed	Yes
18	5500	FCC Radar Type 2	Waveform 18	Completed	Yes
19	5500	FCC Radar Type 2	Waveform 19	Completed	Yes
20	5500	FCC Radar Type 2	Waveform 20	Completed	Yes
21	5500	FCC Radar Type 2	Waveform 21	Completed	Yes
22	5500	FCC Radar Type 2	Waveform 22	Completed	Yes
23	5500	FCC Radar Type 2	Waveform 23	Completed	Yes
24	5500	FCC Radar Type 2	Waveform 24	Completed	Yes
25	5500	FCC Radar Type 2	Waveform 25	Completed	Yes
26	5500	FCC Radar Type 2	Waveform 26	Completed	Yes
27	5500	FCC Radar Type 2	Waveform 27	Completed	Yes
28	5500	FCC Radar Type 2	Waveform 28	Completed	Yes
29	5500	FCC Radar Type 2	Waveform 29	Completed	Yes
30	5500	FCC Radar Type 2	Waveform 30	Completed	Yes

Detection Probability Rate %: 100.00

### Test Result-5500MHz – 20MHz

Trials	Frequency (MHz)	Radar Type	Waveform Type	Status	Result
1	5500	FCC Radar Type 3	Waveform 1	Completed	Yes
2	5500	FCC Radar Type 3	Waveform 2	Completed	Yes
3	5500	FCC Radar Type 3	Waveform 3	Completed	Yes
4	5500	FCC Radar Type 3	Waveform 4	Completed	Yes
5	5500	FCC Radar Type 3	Waveform 5	Completed	Yes
6	5500	FCC Radar Type 3	Waveform 6	Completed	Yes
7	5500	FCC Radar Type 3	Waveform 7	Completed	Yes
8	5500	FCC Radar Type 3	Waveform 8	Completed	Yes
9	5500	FCC Radar Type 3	Waveform 9	Completed	Yes
10	5500	FCC Radar Type 3	Waveform 10	Completed	Yes
11	5500	FCC Radar Type 3	Waveform 11	Completed	Yes
12	5500	FCC Radar Type 3	Waveform 12	Completed	Yes
13	5500	FCC Radar Type 3	Waveform 13	Completed	Yes
14	5500	FCC Radar Type 3	Waveform 14	Completed	Yes
15	5500	FCC Radar Type 3	Waveform 15	Completed	Yes
16	5500	FCC Radar Type 3	Waveform 16	Completed	Yes
17	5500	FCC Radar Type 3	Waveform 17	Completed	Yes
18	5500	FCC Radar Type 3	Waveform 18	Completed	Yes
19	5500	FCC Radar Type 3	Waveform 19	Completed	Yes
20	5500	FCC Radar Type 3	Waveform 20	Completed	Yes
21	5500	FCC Radar Type 3	Waveform 21	Completed	Yes
22	5500	FCC Radar Type 3	Waveform 22	Completed	Yes
23	5500	FCC Radar Type 3	Waveform 23	Completed	Yes
24	5500	FCC Radar Type 3	Waveform 24	Completed	Yes
25	5500	FCC Radar Type 3	Waveform 25	Completed	Yes
26	5500	FCC Radar Type 3	Waveform 26	Completed	Yes
27	5500	FCC Radar Type 3	Waveform 27	Completed	Yes
28	5500	FCC Radar Type 3	Waveform 28	Completed	Yes
29	5500	FCC Radar Type 3	Waveform 29	Completed	Yes
30	5500	FCC Radar Type 3	Waveform 30	Completed	Yes

Detection Probability Rate %: 100.00

### Test Result-5500MHz – 20MHz

Trials	Frequency (MHz)	Radar Type	Waveform Type	Status	Result
1	5500	FCC Radar Type 4	Waveform 1	Completed	Yes
2	5500	FCC Radar Type 4	Waveform 2	Completed	Yes
3	5500	FCC Radar Type 4	Waveform 3	Completed	Yes
4	5500	FCC Radar Type 4	Waveform 4	Completed	Yes
5	5500	FCC Radar Type 4	Waveform 5	Completed	Yes
6	5500	FCC Radar Type 4	Waveform 6	Completed	Yes
7	5500	FCC Radar Type 4	Waveform 7	Completed	Yes
8	5500	FCC Radar Type 4	Waveform 8	Completed	Yes
9	5500	FCC Radar Type 4	Waveform 9	Completed	Yes
10	5500	FCC Radar Type 4	Waveform 10	Completed	Yes
11	5500	FCC Radar Type 4	Waveform 11	Completed	Yes
12	5500	FCC Radar Type 4	Waveform 12	Completed	Yes
13	5500	FCC Radar Type 4	Waveform 13	Completed	Yes
14	5500	FCC Radar Type 4	Waveform 14	Completed	Yes
15	5500	FCC Radar Type 4	Waveform 15	Completed	Yes
16	5500	FCC Radar Type 4	Waveform 16	Completed	Yes
17	5500	FCC Radar Type 4	Waveform 17	Completed	Yes
18	5500	FCC Radar Type 4	Waveform 18	Completed	Yes
19	5500	FCC Radar Type 4	Waveform 19	Completed	Yes
20	5500	FCC Radar Type 4	Waveform 20	Completed	Yes
21	5500	FCC Radar Type 4	Waveform 21	Completed	Yes
22	5500	FCC Radar Type 4	Waveform 22	Completed	Yes
23	5500	FCC Radar Type 4	Waveform 23	Completed	Yes
24	5500	FCC Radar Type 4	Waveform 24	Completed	Yes
25	5500	FCC Radar Type 4	Waveform 25	Completed	Yes
26	5500	FCC Radar Type 4	Waveform 26	Completed	Yes
27	5500	FCC Radar Type 4	Waveform 27	Completed	Yes
28	5500	FCC Radar Type 4	Waveform 28	Completed	Yes
29	5500	FCC Radar Type 4	Waveform 29	Completed	Yes
30	5500	FCC Radar Type 4	Waveform 30	Completed	Yes

Detection Probability Rate %: 100.00

### Test Result-5500MHz – 20MHz

Trial	Frequency (MHz)	Radar Type	Waveform Type	Status	Result
1	5503	FCC Radar Type 5	Waveform 1	Completed	Yes
2	5501	FCC Radar Type 5	Waveform 2	Completed	Yes
3	5502	FCC Radar Type 5	Waveform 3	Completed	Yes
4	5501	FCC Radar Type 5	Waveform 4	Completed	Yes
5	5505	FCC Radar Type 5	Waveform 5	Completed	Yes
6	5506	FCC Radar Type 5	Waveform 6	Completed	Yes
7	5502	FCC Radar Type 5	Waveform 7	Completed	Yes
8	5507	FCC Radar Type 5	Waveform 8	Completed	Yes
9	5506	FCC Radar Type 5	Waveform 9	Completed	Yes
10	5502	FCC Radar Type 5	Waveform 10	Completed	Yes
11	5505	FCC Radar Type 5	Waveform 11	Completed	Yes
12	5506	FCC Radar Type 5	Waveform 12	Completed	Yes
13	5503	FCC Radar Type 5	Waveform 13	Completed	Yes
14	5506	FCC Radar Type 5	Waveform 14	Completed	Yes
15	5506	FCC Radar Type 5	Waveform 15	Completed	Yes
16	5500	FCC Radar Type 5	Waveform 16	Completed	Yes
17	5496	FCC Radar Type 5	Waveform 17	Completed	Yes
18	5494	FCC Radar Type 5	Waveform 18	Completed	Yes
19	5495	FCC Radar Type 5	Waveform 19	Completed	Yes
20	5495	FCC Radar Type 5	Waveform 20	Completed	Yes
21	5499	FCC Radar Type 5	Waveform 21	Completed	Yes
22	5497	FCC Radar Type 5	Waveform 22	Completed	Yes
23	5496	FCC Radar Type 5	Waveform 23	Completed	Yes
24	5498	FCC Radar Type 5	Waveform 24	Completed	Yes
25	5495	FCC Radar Type 5	Waveform 25	Completed	Yes
26	5497	FCC Radar Type 5	Waveform 26	Completed	NO
27	5500	FCC Radar Type 5	Waveform 27	Completed	Yes
28	5499	FCC Radar Type 5	Waveform 28	Completed	Yes
29	5498	FCC Radar Type 5	Waveform 29	Completed	Yes
30	5497	FCC Radar Type 5	Waveform 30	Completed	Yes

Occupied BW: 17.741MHz, 80%\*17.741=14.192MHz, The frequency range from 5293MHz to 5307MHz

Detection Probability Rate %: 96.67

**Note:** Per 905462 D02 UNII DFS Compliance Procedures New Rules v01r02. The center frequency for each of the 30 trials of the Bin 5 radar shall be randomly selected within 80% of the Occupied Bandwidth.

### Test Result-5500MHz – 20MHz

Trials	Frequency (MHz)	Radar Type	Waveform Type	Status	Result
1	5500	FCC Radar Type 6	Waveform 1	Completed	Yes
2	5500	FCC Radar Type 6	Waveform 2	Completed	Yes
3	5500	FCC Radar Type 6	Waveform 3	Completed	Yes
4	5500	FCC Radar Type 6	Waveform 4	Completed	Yes
5	5500	FCC Radar Type 6	Waveform 5	Completed	Yes
6	5500	FCC Radar Type 6	Waveform 6	Completed	Yes
7	5500	FCC Radar Type 6	Waveform 7	Completed	Yes
8	5500	FCC Radar Type 6	Waveform 8	Completed	Yes
9	5500	FCC Radar Type 6	Waveform 9	Completed	Yes
10	5500	FCC Radar Type 6	Waveform 10	Completed	Yes
11	5500	FCC Radar Type 6	Waveform 11	Completed	Yes
12	5500	FCC Radar Type 6	Waveform 12	Completed	Yes
13	5500	FCC Radar Type 6	Waveform 13	Completed	Yes
14	5500	FCC Radar Type 6	Waveform 14	Completed	Yes
15	5500	FCC Radar Type 6	Waveform 15	Completed	Yes
16	5500	FCC Radar Type 6	Waveform 16	Completed	Yes
17	5500	FCC Radar Type 6	Waveform 17	Completed	Yes
18	5500	FCC Radar Type 6	Waveform 18	Completed	Yes
19	5500	FCC Radar Type 6	Waveform 19	Completed	Yes
20	5500	FCC Radar Type 6	Waveform 20	Completed	Yes
21	5500	FCC Radar Type 6	Waveform 21	Completed	Yes
22	5500	FCC Radar Type 6	Waveform 22	Completed	Yes
23	5500	FCC Radar Type 6	Waveform 23	Completed	Yes
24	5500	FCC Radar Type 6	Waveform 24	Completed	Yes
25	5500	FCC Radar Type 6	Waveform 25	Completed	Yes
26	5500	FCC Radar Type 6	Waveform 26	Completed	Yes
27	5500	FCC Radar Type 6	Waveform 27	Completed	Yes
28	5500	FCC Radar Type 6	Waveform 28	Completed	Yes
29	5500	FCC Radar Type 6	Waveform 29	Completed	Yes
30	5500	FCC Radar Type 6	Waveform 30	Completed	Yes
Detection Probability Rate %: 100.00					

### Test Result-5310MHz – 40MHz

Trials	Frequency (MHz)	Radar Type	Waveform Type	Status	Result
1	5310	FCC Radar Type 1	Waveform 1	Completed	Yes
2	5310	FCC Radar Type 1	Waveform 2	Completed	Yes
3	5310	FCC Radar Type 1	Waveform 3	Completed	Yes
4	5310	FCC Radar Type 1	Waveform 4	Completed	Yes
5	5310	FCC Radar Type 1	Waveform 5	Completed	Yes
6	5310	FCC Radar Type 1	Waveform 6	Completed	Yes
7	5310	FCC Radar Type 1	Waveform 7	Completed	Yes
8	5310	FCC Radar Type 1	Waveform 8	Completed	Yes
9	5310	FCC Radar Type 1	Waveform 9	Completed	Yes
10	5310	FCC Radar Type 1	Waveform 10	Completed	Yes
11	5310	FCC Radar Type 1	Waveform 11	Completed	Yes
12	5310	FCC Radar Type 1	Waveform 12	Completed	Yes
13	5310	FCC Radar Type 1	Waveform 13	Completed	Yes
14	5310	FCC Radar Type 1	Waveform 14	Completed	Yes
15	5310	FCC Radar Type 1	Waveform 15	Completed	Yes
16	5310	FCC Radar Type 1	Waveform 16	Completed	Yes
17	5310	FCC Radar Type 1	Waveform 17	Completed	Yes
18	5310	FCC Radar Type 1	Waveform 18	Completed	Yes
19	5310	FCC Radar Type 1	Waveform 19	Completed	Yes
20	5310	FCC Radar Type 1	Waveform 20	Completed	Yes
21	5310	FCC Radar Type 1	Waveform 21	Completed	Yes
22	5310	FCC Radar Type 1	Waveform 22	Completed	Yes
23	5310	FCC Radar Type 1	Waveform 23	Completed	Yes
24	5310	FCC Radar Type 1	Waveform 24	Completed	Yes
25	5310	FCC Radar Type 1	Waveform 25	Completed	Yes
26	5310	FCC Radar Type 1	Waveform 26	Completed	Yes
27	5310	FCC Radar Type 1	Waveform 27	Completed	Yes
28	5310	FCC Radar Type 1	Waveform 28	Completed	Yes
29	5310	FCC Radar Type 1	Waveform 29	Completed	Yes
30	5310	FCC Radar Type 1	Waveform 30	Completed	Yes
Detection Probability Rate %: 100.00					

### Test Result-5310MHz – 40MHz

Trials	Frequency (MHz)	Radar Type	Waveform Type	Status	Result
1	5310	FCC Radar Type 2	Waveform 1	Completed	Yes
2	5310	FCC Radar Type 2	Waveform 2	Completed	Yes
3	5310	FCC Radar Type 2	Waveform 3	Completed	Yes
4	5310	FCC Radar Type 2	Waveform 4	Completed	Yes
5	5310	FCC Radar Type 2	Waveform 5	Completed	Yes
6	5310	FCC Radar Type 2	Waveform 6	Completed	Yes
7	5310	FCC Radar Type 2	Waveform 7	Completed	Yes
8	5310	FCC Radar Type 2	Waveform 8	Completed	Yes
9	5310	FCC Radar Type 2	Waveform 9	Completed	Yes
10	5310	FCC Radar Type 2	Waveform 10	Completed	Yes
11	5310	FCC Radar Type 2	Waveform 11	Completed	Yes
12	5310	FCC Radar Type 2	Waveform 12	Completed	Yes
13	5310	FCC Radar Type 2	Waveform 13	Completed	Yes
14	5310	FCC Radar Type 2	Waveform 14	Completed	Yes
15	5310	FCC Radar Type 2	Waveform 15	Completed	Yes
16	5310	FCC Radar Type 2	Waveform 16	Completed	Yes
17	5310	FCC Radar Type 2	Waveform 17	Completed	Yes
18	5310	FCC Radar Type 2	Waveform 18	Completed	Yes
19	5310	FCC Radar Type 2	Waveform 19	Completed	Yes
20	5310	FCC Radar Type 2	Waveform 20	Completed	Yes
21	5310	FCC Radar Type 2	Waveform 21	Completed	Yes
22	5310	FCC Radar Type 2	Waveform 22	Completed	Yes
23	5310	FCC Radar Type 2	Waveform 23	Completed	Yes
24	5310	FCC Radar Type 2	Waveform 24	Completed	Yes
25	5310	FCC Radar Type 2	Waveform 25	Completed	Yes
26	5310	FCC Radar Type 2	Waveform 26	Completed	Yes
27	5310	FCC Radar Type 2	Waveform 27	Completed	Yes
28	5310	FCC Radar Type 2	Waveform 28	Completed	Yes
29	5310	FCC Radar Type 2	Waveform 29	Completed	Yes
30	5310	FCC Radar Type 2	Waveform 30	Completed	Yes
Detection Probability Rate %:					100.00

### Test Result-5310MHz – 40MHz

Trials	Frequency (MHz)	Radar Type	Waveform Type	Status	Result
1	5310	FCC Radar Type 3	Waveform 1	Completed	Yes
2	5310	FCC Radar Type 3	Waveform 2	Completed	Yes
3	5310	FCC Radar Type 3	Waveform 3	Completed	Yes
4	5310	FCC Radar Type 3	Waveform 4	Completed	Yes
5	5310	FCC Radar Type 3	Waveform 5	Completed	Yes
6	5310	FCC Radar Type 3	Waveform 6	Completed	Yes
7	5310	FCC Radar Type 3	Waveform 7	Completed	Yes
8	5310	FCC Radar Type 3	Waveform 8	Completed	Yes
9	5310	FCC Radar Type 3	Waveform 9	Completed	Yes
10	5310	FCC Radar Type 3	Waveform 10	Completed	Yes
11	5310	FCC Radar Type 3	Waveform 11	Completed	Yes
12	5310	FCC Radar Type 3	Waveform 12	Completed	Yes
13	5310	FCC Radar Type 3	Waveform 13	Completed	Yes
14	5310	FCC Radar Type 3	Waveform 14	Completed	Yes
15	5310	FCC Radar Type 3	Waveform 15	Completed	Yes
16	5310	FCC Radar Type 3	Waveform 16	Completed	Yes
17	5310	FCC Radar Type 3	Waveform 17	Completed	Yes
18	5310	FCC Radar Type 3	Waveform 18	Completed	Yes
19	5310	FCC Radar Type 3	Waveform 19	Completed	Yes
20	5310	FCC Radar Type 3	Waveform 20	Completed	Yes
21	5310	FCC Radar Type 3	Waveform 21	Completed	Yes
22	5310	FCC Radar Type 3	Waveform 22	Completed	Yes
23	5310	FCC Radar Type 3	Waveform 23	Completed	Yes
24	5310	FCC Radar Type 3	Waveform 24	Completed	Yes
25	5310	FCC Radar Type 3	Waveform 25	Completed	Yes
26	5310	FCC Radar Type 3	Waveform 26	Completed	Yes
27	5310	FCC Radar Type 3	Waveform 27	Completed	Yes
28	5310	FCC Radar Type 3	Waveform 28	Completed	Yes
29	5310	FCC Radar Type 3	Waveform 29	Completed	Yes
30	5310	FCC Radar Type 3	Waveform 30	Completed	Yes

Detection Probability Rate %: 100.00

### Test Result-5310MHz – 40MHz

Trials	Frequency (MHz)	Radar Type	Waveform Type	Status	Result
1	5310	FCC Radar Type 4	Waveform 1	Completed	Yes
2	5310	FCC Radar Type 4	Waveform 2	Completed	Yes
3	5310	FCC Radar Type 4	Waveform 3	Completed	Yes
4	5310	FCC Radar Type 4	Waveform 4	Completed	Yes
5	5310	FCC Radar Type 4	Waveform 5	Completed	Yes
6	5310	FCC Radar Type 4	Waveform 6	Completed	Yes
7	5310	FCC Radar Type 4	Waveform 7	Completed	Yes
8	5310	FCC Radar Type 4	Waveform 8	Completed	NO
9	5310	FCC Radar Type 4	Waveform 9	Completed	Yes
10	5310	FCC Radar Type 4	Waveform 10	Completed	Yes
11	5310	FCC Radar Type 4	Waveform 11	Completed	Yes
12	5310	FCC Radar Type 4	Waveform 12	Completed	Yes
13	5310	FCC Radar Type 4	Waveform 13	Completed	Yes
14	5310	FCC Radar Type 4	Waveform 14	Completed	Yes
15	5310	FCC Radar Type 4	Waveform 15	Completed	NO
16	5310	FCC Radar Type 4	Waveform 16	Completed	Yes
17	5310	FCC Radar Type 4	Waveform 17	Completed	Yes
18	5310	FCC Radar Type 4	Waveform 18	Completed	Yes
19	5310	FCC Radar Type 4	Waveform 19	Completed	Yes
20	5310	FCC Radar Type 4	Waveform 20	Completed	Yes
21	5310	FCC Radar Type 4	Waveform 21	Completed	NO
22	5310	FCC Radar Type 4	Waveform 22	Completed	Yes
23	5310	FCC Radar Type 4	Waveform 23	Completed	Yes
24	5310	FCC Radar Type 4	Waveform 24	Completed	Yes
25	5310	FCC Radar Type 4	Waveform 25	Completed	Yes
26	5310	FCC Radar Type 4	Waveform 26	Completed	Yes
27	5310	FCC Radar Type 4	Waveform 27	Completed	Yes
28	5310	FCC Radar Type 4	Waveform 28	Completed	Yes
29	5310	FCC Radar Type 4	Waveform 29	Completed	Yes
30	5310	FCC Radar Type 4	Waveform 30	Completed	Yes
Detection Probability Rate %:					90.00

### Test Result-5310MHz – 40MHz

Trials	Frequency (MHz)	Radar Type	Waveform Type	Status	Result
1	5315	FCC Radar Type 5	Waveform 1	Completed	Yes
2	5311	FCC Radar Type 5	Waveform 2	Completed	Yes
3	5311	FCC Radar Type 5	Waveform 3	Completed	Yes
4	5313	FCC Radar Type 5	Waveform 4	Completed	Yes
5	5319	FCC Radar Type 5	Waveform 5	Completed	Yes
6	5317	FCC Radar Type 5	Waveform 6	Completed	Yes
7	5322	FCC Radar Type 5	Waveform 7	Completed	Yes
8	5310	FCC Radar Type 5	Waveform 8	Completed	Yes
9	5314	FCC Radar Type 5	Waveform 9	Completed	Yes
10	5311	FCC Radar Type 5	Waveform 10	Completed	Yes
11	5320	FCC Radar Type 5	Waveform 11	Completed	Yes
12	5315	FCC Radar Type 5	Waveform 12	Completed	Yes
13	5312	FCC Radar Type 5	Waveform 13	Completed	Yes
14	5316	FCC Radar Type 5	Waveform 14	Completed	Yes
15	5317	FCC Radar Type 5	Waveform 15	Completed	Yes
16	5309	FCC Radar Type 5	Waveform 16	Completed	Yes
17	5308	FCC Radar Type 5	Waveform 17	Completed	Yes
18	5308	FCC Radar Type 5	Waveform 18	Completed	Yes
19	5303	FCC Radar Type 5	Waveform 19	Completed	Yes
20	5307	FCC Radar Type 5	Waveform 20	Completed	Yes
21	5298	FCC Radar Type 5	Waveform 21	Completed	Yes
22	5303	FCC Radar Type 5	Waveform 22	Completed	Yes
23	5308	FCC Radar Type 5	Waveform 23	Completed	No
24	5305	FCC Radar Type 5	Waveform 24	Completed	Yes
25	5301	FCC Radar Type 5	Waveform 25	Completed	Yes
26	5299	FCC Radar Type 5	Waveform 26	Completed	Yes
27	5300	FCC Radar Type 5	Waveform 27	Completed	Yes
28	5303	FCC Radar Type 5	Waveform 28	Completed	Yes
29	5296	FCC Radar Type 5	Waveform 29	Completed	Yes
30	5302	FCC Radar Type 5	Waveform 30	Completed	Yes
Occupied BW: 17.741MHz, 80%*17.741=14.192MHz, The frequency range from 5293MHz to 5307MHz					
Detection Probability Rate %: 96.67					

**Note: Per 905462 D02 UNII DFS Compliance Procedures New Rules v01r02. The center frequency for each of the 30 trials of the Bin 5 radar shall be randomly selected within 80% of the Occupied Bandwidth.**

### Test Result-5310MHz – 40MHz

Trials	Frequency (MHz)	Radar Type	Waveform Type	Status	Result
1	5310	FCC Radar Type 6	Waveform 1	Completed	Yes
2	5310	FCC Radar Type 6	Waveform 2	Completed	Yes
3	5310	FCC Radar Type 6	Waveform 3	Completed	Yes
4	5310	FCC Radar Type 6	Waveform 4	Completed	Yes
5	5310	FCC Radar Type 6	Waveform 5	Completed	Yes
6	5310	FCC Radar Type 6	Waveform 6	Completed	Yes
7	5310	FCC Radar Type 6	Waveform 7	Completed	Yes
8	5310	FCC Radar Type 6	Waveform 8	Completed	Yes
9	5310	FCC Radar Type 6	Waveform 9	Completed	Yes
10	5310	FCC Radar Type 6	Waveform 10	Completed	Yes
11	5310	FCC Radar Type 6	Waveform 11	Completed	Yes
12	5310	FCC Radar Type 6	Waveform 12	Completed	Yes
13	5310	FCC Radar Type 6	Waveform 13	Completed	Yes
14	5310	FCC Radar Type 6	Waveform 14	Completed	Yes
15	5310	FCC Radar Type 6	Waveform 15	Completed	Yes
16	5310	FCC Radar Type 6	Waveform 16	Completed	Yes
17	5310	FCC Radar Type 6	Waveform 17	Completed	Yes
18	5310	FCC Radar Type 6	Waveform 18	Completed	Yes
19	5310	FCC Radar Type 6	Waveform 19	Completed	Yes
20	5310	FCC Radar Type 6	Waveform 20	Completed	Yes
21	5310	FCC Radar Type 6	Waveform 21	Completed	Yes
22	5310	FCC Radar Type 6	Waveform 22	Completed	Yes
23	5310	FCC Radar Type 6	Waveform 23	Completed	Yes
24	5310	FCC Radar Type 6	Waveform 24	Completed	Yes
25	5310	FCC Radar Type 6	Waveform 25	Completed	Yes
26	5310	FCC Radar Type 6	Waveform 26	Completed	Yes
27	5310	FCC Radar Type 6	Waveform 27	Completed	Yes
28	5310	FCC Radar Type 6	Waveform 28	Completed	Yes
29	5310	FCC Radar Type 6	Waveform 29	Completed	Yes
30	5310	FCC Radar Type 6	Waveform 30	Completed	Yes

Detection Probability Rate %: 100.00

### Test Result-5510MHz – 40MHz

Trials	Frequency (MHz)	Radar Type	Waveform Type	Status	Result
1	5510	FCC Radar Type 1	Waveform 1	Completed	Yes
2	5510	FCC Radar Type 1	Waveform 2	Completed	Yes
3	5510	FCC Radar Type 1	Waveform 3	Completed	Yes
4	5510	FCC Radar Type 1	Waveform 4	Completed	Yes
5	5510	FCC Radar Type 1	Waveform 5	Completed	Yes
6	5510	FCC Radar Type 1	Waveform 6	Completed	Yes
7	5510	FCC Radar Type 1	Waveform 7	Completed	Yes
8	5510	FCC Radar Type 1	Waveform 8	Completed	Yes
9	5510	FCC Radar Type 1	Waveform 9	Completed	Yes
10	5510	FCC Radar Type 1	Waveform 10	Completed	Yes
11	5510	FCC Radar Type 1	Waveform 11	Completed	Yes
12	5510	FCC Radar Type 1	Waveform 12	Completed	Yes
13	5510	FCC Radar Type 1	Waveform 13	Completed	Yes
14	5510	FCC Radar Type 1	Waveform 14	Completed	Yes
15	5510	FCC Radar Type 1	Waveform 15	Completed	Yes
16	5510	FCC Radar Type 1	Waveform 16	Completed	Yes
17	5510	FCC Radar Type 1	Waveform 17	Completed	Yes
18	5510	FCC Radar Type 1	Waveform 18	Completed	Yes
19	5510	FCC Radar Type 1	Waveform 19	Completed	Yes
20	5510	FCC Radar Type 1	Waveform 20	Completed	Yes
21	5510	FCC Radar Type 1	Waveform 21	Completed	Yes
22	5510	FCC Radar Type 1	Waveform 22	Completed	Yes
23	5510	FCC Radar Type 1	Waveform 23	Completed	Yes
24	5510	FCC Radar Type 1	Waveform 24	Completed	Yes
25	5510	FCC Radar Type 1	Waveform 25	Completed	Yes
26	5510	FCC Radar Type 1	Waveform 26	Completed	Yes
27	5510	FCC Radar Type 1	Waveform 27	Completed	Yes
28	5510	FCC Radar Type 1	Waveform 28	Completed	Yes
29	5510	FCC Radar Type 1	Waveform 29	Completed	Yes
30	5510	FCC Radar Type 1	Waveform 30	Completed	Yes
Detection Probability Rate %: 100.00					

### Test Result-5510MHz – 40MHz

Trials	Frequency (MHz)	Radar Type	Waveform Type	Status	Result
1	5510	FCC Radar Type 2	Waveform 1	Completed	Yes
2	5510	FCC Radar Type 2	Waveform 2	Completed	Yes
3	5510	FCC Radar Type 2	Waveform 3	Completed	Yes
4	5510	FCC Radar Type 2	Waveform 4	Completed	Yes
5	5510	FCC Radar Type 2	Waveform 5	Completed	Yes
6	5510	FCC Radar Type 2	Waveform 6	Completed	Yes
7	5510	FCC Radar Type 2	Waveform 7	Completed	Yes
8	5510	FCC Radar Type 2	Waveform 8	Completed	Yes
9	5510	FCC Radar Type 2	Waveform 9	Completed	Yes
10	5510	FCC Radar Type 2	Waveform 10	Completed	Yes
11	5510	FCC Radar Type 2	Waveform 11	Completed	Yes
12	5510	FCC Radar Type 2	Waveform 12	Completed	Yes
13	5510	FCC Radar Type 2	Waveform 13	Completed	Yes
14	5510	FCC Radar Type 2	Waveform 14	Completed	Yes
15	5510	FCC Radar Type 2	Waveform 15	Completed	Yes
16	5510	FCC Radar Type 2	Waveform 16	Completed	Yes
17	5510	FCC Radar Type 2	Waveform 17	Completed	Yes
18	5510	FCC Radar Type 2	Waveform 18	Completed	Yes
19	5510	FCC Radar Type 2	Waveform 19	Completed	Yes
20	5510	FCC Radar Type 2	Waveform 20	Completed	Yes
21	5510	FCC Radar Type 2	Waveform 21	Completed	Yes
22	5510	FCC Radar Type 2	Waveform 22	Completed	Yes
23	5510	FCC Radar Type 2	Waveform 23	Completed	Yes
24	5510	FCC Radar Type 2	Waveform 24	Completed	Yes
25	5510	FCC Radar Type 2	Waveform 25	Completed	Yes
26	5510	FCC Radar Type 2	Waveform 26	Completed	Yes
27	5510	FCC Radar Type 2	Waveform 27	Completed	Yes
28	5510	FCC Radar Type 2	Waveform 28	Completed	Yes
29	5510	FCC Radar Type 2	Waveform 29	Completed	Yes
30	5510	FCC Radar Type 2	Waveform 30	Completed	Yes
Detection Probability Rate %: 100.00					

### Test Result-5510MHz – 40MHz

Trials	Frequency (MHz)	Radar Type	Waveform Type	Status	Result
1	5510	FCC Radar Type 3	Waveform 1	Completed	Yes
2	5510	FCC Radar Type 3	Waveform 2	Completed	Yes
3	5510	FCC Radar Type 3	Waveform 3	Completed	Yes
4	5510	FCC Radar Type 3	Waveform 4	Completed	Yes
5	5510	FCC Radar Type 3	Waveform 5	Completed	Yes
6	5510	FCC Radar Type 3	Waveform 6	Completed	Yes
7	5510	FCC Radar Type 3	Waveform 7	Completed	Yes
8	5510	FCC Radar Type 3	Waveform 8	Completed	Yes
9	5510	FCC Radar Type 3	Waveform 9	Completed	Yes
10	5510	FCC Radar Type 3	Waveform 10	Completed	Yes
11	5510	FCC Radar Type 3	Waveform 11	Completed	Yes
12	5510	FCC Radar Type 3	Waveform 12	Completed	Yes
13	5510	FCC Radar Type 3	Waveform 13	Completed	Yes
14	5510	FCC Radar Type 3	Waveform 14	Completed	Yes
15	5510	FCC Radar Type 3	Waveform 15	Completed	Yes
16	5510	FCC Radar Type 3	Waveform 16	Completed	Yes
17	5510	FCC Radar Type 3	Waveform 17	Completed	Yes
18	5510	FCC Radar Type 3	Waveform 18	Completed	Yes
19	5510	FCC Radar Type 3	Waveform 19	Completed	Yes
20	5510	FCC Radar Type 3	Waveform 20	Completed	Yes
21	5510	FCC Radar Type 3	Waveform 21	Completed	Yes
22	5510	FCC Radar Type 3	Waveform 22	Completed	Yes
23	5510	FCC Radar Type 3	Waveform 23	Completed	Yes
24	5510	FCC Radar Type 3	Waveform 24	Completed	Yes
25	5510	FCC Radar Type 3	Waveform 25	Completed	Yes
26	5510	FCC Radar Type 3	Waveform 26	Completed	Yes
27	5510	FCC Radar Type 3	Waveform 27	Completed	Yes
28	5510	FCC Radar Type 3	Waveform 28	Completed	Yes
29	5510	FCC Radar Type 3	Waveform 29	Completed	Yes
30	5510	FCC Radar Type 3	Waveform 30	Completed	Yes
Detection Probability Rate %: 100.00					

### Test Result-5510MHz – 40MHz

Trials	Frequency (MHz)	Radar Type	Waveform Type	Status	Result
1	5510	FCC Radar Type 4	Waveform 1	Completed	Yes
2	5510	FCC Radar Type 4	Waveform 2	Completed	Yes
3	5510	FCC Radar Type 4	Waveform 3	Completed	Yes
4	5510	FCC Radar Type 4	Waveform 4	Completed	Yes
5	5510	FCC Radar Type 4	Waveform 5	Completed	Yes
6	5510	FCC Radar Type 4	Waveform 6	Completed	Yes
7	5510	FCC Radar Type 4	Waveform 7	Completed	Yes
8	5510	FCC Radar Type 4	Waveform 8	Completed	Yes
9	5510	FCC Radar Type 4	Waveform 9	Completed	Yes
10	5510	FCC Radar Type 4	Waveform 10	Completed	Yes
11	5510	FCC Radar Type 4	Waveform 11	Completed	NO
12	5510	FCC Radar Type 4	Waveform 12	Completed	Yes
13	5510	FCC Radar Type 4	Waveform 13	Completed	Yes
14	5510	FCC Radar Type 4	Waveform 14	Completed	Yes
15	5510	FCC Radar Type 4	Waveform 15	Completed	Yes
16	5510	FCC Radar Type 4	Waveform 16	Completed	Yes
17	5510	FCC Radar Type 4	Waveform 17	Completed	Yes
18	5510	FCC Radar Type 4	Waveform 18	Completed	No
19	5510	FCC Radar Type 4	Waveform 19	Completed	Yes
20	5510	FCC Radar Type 4	Waveform 20	Completed	Yes
21	5510	FCC Radar Type 4	Waveform 21	Completed	Yes
22	5510	FCC Radar Type 4	Waveform 22	Completed	No
23	5510	FCC Radar Type 4	Waveform 23	Completed	Yes
24	5510	FCC Radar Type 4	Waveform 24	Completed	Yes
25	5510	FCC Radar Type 4	Waveform 25	Completed	No
26	5510	FCC Radar Type 4	Waveform 26	Completed	Yes
27	5510	FCC Radar Type 4	Waveform 27	Completed	Yes
28	5510	FCC Radar Type 4	Waveform 28	Completed	Yes
29	5510	FCC Radar Type 4	Waveform 29	Completed	Yes
30	5510	FCC Radar Type 4	Waveform 30	Completed	Yes
Detection Probability Rate %:86.67					

### Test Result-5510MHz – 40MHz

Trials	Frequency (MHz)	Radar Type	Waveform Type	Status	Result
1	5522	FCC Radar Type 5	Waveform 1	Completed	Yes
2	5514	FCC Radar Type 5	Waveform 2	Completed	Yes
3	5523	FCC Radar Type 5	Waveform 3	Completed	Yes
4	5517	FCC Radar Type 5	Waveform 4	Completed	Yes
5	5520	FCC Radar Type 5	Waveform 5	Completed	Yes
6	5516	FCC Radar Type 5	Waveform 6	Completed	Yes
7	5522	FCC Radar Type 5	Waveform 7	Completed	Yes
8	5520	FCC Radar Type 5	Waveform 8	Completed	Yes
9	5512	FCC Radar Type 5	Waveform 9	Completed	Yes
10	5515	FCC Radar Type 5	Waveform 10	Completed	Yes
11	5513	FCC Radar Type 5	Waveform 11	Completed	Yes
12	5524	FCC Radar Type 5	Waveform 12	Completed	Yes
13	5516	FCC Radar Type 5	Waveform 13	Completed	Yes
14	5515	FCC Radar Type 5	Waveform 14	Completed	No
15	5521	FCC Radar Type 5	Waveform 15	Completed	Yes
16	5508	FCC Radar Type 5	Waveform 16	Completed	Yes
17	5506	FCC Radar Type 5	Waveform 17	Completed	Yes
18	5509	FCC Radar Type 5	Waveform 18	Completed	Yes
19	5502	FCC Radar Type 5	Waveform 19	Completed	Yes
20	5505	FCC Radar Type 5	Waveform 20	Completed	Yes
21	5500	FCC Radar Type 5	Waveform 21	Completed	Yes
22	5502	FCC Radar Type 5	Waveform 22	Completed	Yes
23	5497	FCC Radar Type 5	Waveform 23	Completed	Yes
24	5498	FCC Radar Type 5	Waveform 24	Completed	Yes
25	5501	FCC Radar Type 5	Waveform 25	Completed	Yes
26	5497	FCC Radar Type 5	Waveform 26	Completed	Yes
27	5498	FCC Radar Type 5	Waveform 27	Completed	Yes
28	5498	FCC Radar Type 5	Waveform 28	Completed	Yes
29	5505	FCC Radar Type 5	Waveform 29	Completed	Yes
30	5500	FCC Radar Type 5	Waveform 30	Completed	Yes
Occupied BW: 17.741MHz, 80%*17.741=14.192MHz, The frequency range from 5293MHz to 5307MHz					
Detection Probability Rate %: 96.67					

**Note: Per 905462 D02 UNII DFS Compliance Procedures New Rules v01r02. The center frequency for each of the 30 trials of the Bin 5 radar shall be randomly selected within 80% of the Occupied Bandwidth.**

### Test Result-5510MHz – 40MHz

Trials	Frequency (MHz)	Radar Type	Waveform Type	Status	Result
1	5510	FCC Radar Type 6	Waveform 1	Completed	Yes
2	5510	FCC Radar Type 6	Waveform 2	Completed	Yes
3	5510	FCC Radar Type 6	Waveform 3	Completed	Yes
4	5510	FCC Radar Type 6	Waveform 4	Completed	Yes
5	5510	FCC Radar Type 6	Waveform 5	Completed	Yes
6	5510	FCC Radar Type 6	Waveform 6	Completed	Yes
7	5510	FCC Radar Type 6	Waveform 7	Completed	Yes
8	5510	FCC Radar Type 6	Waveform 8	Completed	Yes
9	5510	FCC Radar Type 6	Waveform 9	Completed	Yes
10	5510	FCC Radar Type 6	Waveform 10	Completed	Yes
11	5510	FCC Radar Type 6	Waveform 11	Completed	Yes
12	5510	FCC Radar Type 6	Waveform 12	Completed	Yes
13	5510	FCC Radar Type 6	Waveform 13	Completed	Yes
14	5510	FCC Radar Type 6	Waveform 14	Completed	Yes
15	5510	FCC Radar Type 6	Waveform 15	Completed	Yes
16	5510	FCC Radar Type 6	Waveform 16	Completed	Yes
17	5510	FCC Radar Type 6	Waveform 17	Completed	Yes
18	5510	FCC Radar Type 6	Waveform 18	Completed	Yes
19	5510	FCC Radar Type 6	Waveform 19	Completed	Yes
20	5510	FCC Radar Type 6	Waveform 20	Completed	Yes
21	5510	FCC Radar Type 6	Waveform 21	Completed	Yes
22	5510	FCC Radar Type 6	Waveform 22	Completed	Yes
23	5510	FCC Radar Type 6	Waveform 23	Completed	Yes
24	5510	FCC Radar Type 6	Waveform 24	Completed	Yes
25	5510	FCC Radar Type 6	Waveform 25	Completed	Yes
26	5510	FCC Radar Type 6	Waveform 26	Completed	Yes
27	5510	FCC Radar Type 6	Waveform 27	Completed	Yes
28	5510	FCC Radar Type 6	Waveform 28	Completed	Yes
29	5510	FCC Radar Type 6	Waveform 29	Completed	Yes
30	5510	FCC Radar Type 6	Waveform 30	Completed	Yes
Detection Probability Rate %: 100.00					

**Test Result-5290MHz – 80MHz**

<b>Trials</b>	<b>Frequency (MHz)</b>	<b>Radar Type</b>	<b>Waveform Type</b>	<b>Status</b>	<b>Result</b>
1	5290	FCC Radar Type 1	Waveform 1	Completed	Yes
2	5290	FCC Radar Type 1	Waveform 2	Completed	Yes
3	5290	FCC Radar Type 1	Waveform 3	Completed	Yes
4	5290	FCC Radar Type 1	Waveform 4	Completed	Yes
5	5290	FCC Radar Type 1	Waveform 5	Completed	Yes
6	5290	FCC Radar Type 1	Waveform 6	Completed	Yes
7	5290	FCC Radar Type 1	Waveform 7	Completed	Yes
8	5290	FCC Radar Type 1	Waveform 8	Completed	Yes
9	5290	FCC Radar Type 1	Waveform 9	Completed	Yes
10	5290	FCC Radar Type 1	Waveform 10	Completed	Yes
11	5290	FCC Radar Type 1	Waveform 11	Completed	Yes
12	5290	FCC Radar Type 1	Waveform 12	Completed	Yes
13	5290	FCC Radar Type 1	Waveform 13	Completed	Yes
14	5290	FCC Radar Type 1	Waveform 14	Completed	Yes
15	5290	FCC Radar Type 1	Waveform 15	Completed	Yes
16	5290	FCC Radar Type 1	Waveform 16	Completed	Yes
17	5290	FCC Radar Type 1	Waveform 17	Completed	Yes
18	5290	FCC Radar Type 1	Waveform 18	Completed	Yes
19	5290	FCC Radar Type 1	Waveform 19	Completed	Yes
20	5290	FCC Radar Type 1	Waveform 20	Completed	Yes
21	5290	FCC Radar Type 1	Waveform 21	Completed	Yes
22	5290	FCC Radar Type 1	Waveform 22	Completed	Yes
23	5290	FCC Radar Type 1	Waveform 23	Completed	Yes
24	5290	FCC Radar Type 1	Waveform 24	Completed	Yes
25	5290	FCC Radar Type 1	Waveform 25	Completed	Yes
26	5290	FCC Radar Type 1	Waveform 26	Completed	Yes
27	5290	FCC Radar Type 1	Waveform 27	Completed	Yes
28	5290	FCC Radar Type 1	Waveform 28	Completed	Yes
29	5290	FCC Radar Type 1	Waveform 29	Completed	Yes
30	5290	FCC Radar Type 1	Waveform 30	Completed	Yes

Detection Probability Rate %: 100.0

**Test Result-5290MHz – 80MHz**

<b>Trials</b>	<b>Frequency (MHz)</b>	<b>Radar Type</b>	<b>Waveform Type</b>	<b>Status</b>	<b>Result</b>
1	5290	FCC Radar Type 2	Waveform 1	Completed	Yes
2	5290	FCC Radar Type 2	Waveform 2	Completed	Yes
3	5290	FCC Radar Type 2	Waveform 3	Completed	Yes
4	5290	FCC Radar Type 2	Waveform 4	Completed	Yes
5	5290	FCC Radar Type 2	Waveform 5	Completed	Yes
6	5290	FCC Radar Type 2	Waveform 6	Completed	Yes
7	5290	FCC Radar Type 2	Waveform 7	Completed	Yes
8	5290	FCC Radar Type 2	Waveform 8	Completed	Yes
9	5290	FCC Radar Type 2	Waveform 9	Completed	Yes
10	5290	FCC Radar Type 2	Waveform 10	Completed	Yes
11	5290	FCC Radar Type 2	Waveform 11	Completed	Yes
12	5290	FCC Radar Type 2	Waveform 12	Completed	Yes
13	5290	FCC Radar Type 2	Waveform 13	Completed	No
14	5290	FCC Radar Type 2	Waveform 14	Completed	Yes
15	5290	FCC Radar Type 2	Waveform 15	Completed	Yes
16	5290	FCC Radar Type 2	Waveform 16	Completed	Yes
17	5290	FCC Radar Type 2	Waveform 17	Completed	Yes
18	5290	FCC Radar Type 2	Waveform 18	Completed	Yes
19	5290	FCC Radar Type 2	Waveform 19	Completed	Yes
20	5290	FCC Radar Type 2	Waveform 20	Completed	Yes
21	5290	FCC Radar Type 2	Waveform 21	Completed	Yes
22	5290	FCC Radar Type 2	Waveform 22	Completed	Yes
23	5290	FCC Radar Type 2	Waveform 23	Completed	Yes
24	5290	FCC Radar Type 2	Waveform 24	Completed	Yes
25	5290	FCC Radar Type 2	Waveform 25	Completed	Yes
26	5290	FCC Radar Type 2	Waveform 26	Completed	Yes
27	5290	FCC Radar Type 2	Waveform 27	Completed	Yes
28	5290	FCC Radar Type 2	Waveform 28	Completed	Yes
29	5290	FCC Radar Type 2	Waveform 29	Completed	Yes
30	5290	FCC Radar Type 2	Waveform 30	Completed	Yes

Detection Probability Rate %: 96.7

**Test Result-5290MHz – 80MHz**

<b>Trials</b>	<b>Frequency (MHz)</b>	<b>Radar Type</b>	<b>Waveform Type</b>	<b>Status</b>	<b>Result</b>
1	5290	FCC Radar Type 3	Waveform 1	Completed	Yes
2	5290	FCC Radar Type 3	Waveform 2	Completed	Yes
3	5290	FCC Radar Type 3	Waveform 3	Completed	Yes
4	5290	FCC Radar Type 3	Waveform 4	Completed	Yes
5	5290	FCC Radar Type 3	Waveform 5	Completed	Yes
6	5290	FCC Radar Type 3	Waveform 6	Completed	Yes
7	5290	FCC Radar Type 3	Waveform 7	Completed	Yes
8	5290	FCC Radar Type 3	Waveform 8	Completed	Yes
9	5290	FCC Radar Type 3	Waveform 9	Completed	Yes
10	5290	FCC Radar Type 3	Waveform 10	Completed	Yes
11	5290	FCC Radar Type 3	Waveform 11	Completed	Yes
12	5290	FCC Radar Type 3	Waveform 12	Completed	Yes
13	5290	FCC Radar Type 3	Waveform 13	Completed	Yes
14	5290	FCC Radar Type 3	Waveform 14	Completed	Yes
15	5290	FCC Radar Type 3	Waveform 15	Completed	Yes
16	5290	FCC Radar Type 3	Waveform 16	Completed	Yes
17	5290	FCC Radar Type 3	Waveform 17	Completed	Yes
18	5290	FCC Radar Type 3	Waveform 18	Completed	Yes
19	5290	FCC Radar Type 3	Waveform 19	Completed	Yes
20	5290	FCC Radar Type 3	Waveform 20	Completed	Yes
21	5290	FCC Radar Type 3	Waveform 21	Completed	Yes
22	5290	FCC Radar Type 3	Waveform 22	Completed	Yes
23	5290	FCC Radar Type 3	Waveform 23	Completed	Yes
24	5290	FCC Radar Type 3	Waveform 24	Completed	Yes
25	5290	FCC Radar Type 3	Waveform 25	Completed	Yes
26	5290	FCC Radar Type 3	Waveform 26	Completed	Yes
27	5290	FCC Radar Type 3	Waveform 27	Completed	Yes
28	5290	FCC Radar Type 3	Waveform 28	Completed	Yes
29	5290	FCC Radar Type 3	Waveform 29	Completed	Yes
30	5290	FCC Radar Type 3	Waveform 30	Completed	Yes

Detection Probability Rate %: 100

**Test Result-5290MHz – 80MHz**

<b>Trials</b>	<b>Frequency (MHz)</b>	<b>Radar Type</b>	<b>Waveform Type</b>	<b>Status</b>	<b>Result</b>
1	5290	FCC Radar Type 4	Waveform 1	Completed	Yes
2	5290	FCC Radar Type 4	Waveform 2	Completed	Yes
3	5290	FCC Radar Type 4	Waveform 3	Completed	Yes
4	5290	FCC Radar Type 4	Waveform 4	Completed	Yes
5	5290	FCC Radar Type 4	Waveform 5	Completed	Yes
6	5290	FCC Radar Type 4	Waveform 6	Completed	Yes
7	5290	FCC Radar Type 4	Waveform 7	Completed	Yes
8	5290	FCC Radar Type 4	Waveform 8	Completed	Yes
9	5290	FCC Radar Type 4	Waveform 9	Completed	Yes
10	5290	FCC Radar Type 4	Waveform 10	Completed	Yes
11	5290	FCC Radar Type 4	Waveform 11	Completed	Yes
12	5290	FCC Radar Type 4	Waveform 12	Completed	Yes
13	5290	FCC Radar Type 4	Waveform 13	Completed	Yes
14	5290	FCC Radar Type 4	Waveform 14	Completed	Yes
15	5290	FCC Radar Type 4	Waveform 15	Completed	Yes
16	5290	FCC Radar Type 4	Waveform 16	Completed	Yes
17	5290	FCC Radar Type 4	Waveform 17	Completed	Yes
18	5290	FCC Radar Type 4	Waveform 18	Completed	Yes
19	5290	FCC Radar Type 4	Waveform 19	Completed	Yes
20	5290	FCC Radar Type 4	Waveform 20	Completed	Yes
21	5290	FCC Radar Type 4	Waveform 21	Completed	Yes
22	5290	FCC Radar Type 4	Waveform 22	Completed	Yes
23	5290	FCC Radar Type 4	Waveform 23	Completed	Yes
24	5290	FCC Radar Type 4	Waveform 24	Completed	Yes
25	5290	FCC Radar Type 4	Waveform 25	Completed	Yes
26	5290	FCC Radar Type 4	Waveform 26	Completed	Yes
27	5290	FCC Radar Type 4	Waveform 27	Completed	Yes
28	5290	FCC Radar Type 4	Waveform 28	Completed	Yes
29	5290	FCC Radar Type 4	Waveform 29	Completed	Yes
30	5290	FCC Radar Type 4	Waveform 30	Completed	Yes

Detection Probability Rate %: 100

**Test Result-5290MHz – 80MHz**

Trials	Frequency (MHz)	Radar Type	Waveform Type	Status	Result
1	5294	FCC Radar Type 5	Waveform 1	Completed	Yes
2	5301	FCC Radar Type 5	Waveform 2	Completed	Yes
3	5292	FCC Radar Type 5	Waveform 3	Completed	Yes
4	5314	FCC Radar Type 5	Waveform 4	Completed	Yes
5	5299	FCC Radar Type 5	Waveform 5	Completed	Yes
6	5303	FCC Radar Type 5	Waveform 6	Completed	Yes
7	5310	FCC Radar Type 5	Waveform 7	Completed	Yes
8	5304	FCC Radar Type 5	Waveform 8	Completed	Yes
9	5312	FCC Radar Type 5	Waveform 9	Completed	Yes
10	5309	FCC Radar Type 5	Waveform 10	Completed	Yes
11	5305	FCC Radar Type 5	Waveform 11	Completed	Yes
12	5314	FCC Radar Type 5	Waveform 12	Completed	Yes
13	5290	FCC Radar Type 5	Waveform 13	Completed	Yes
14	5299	FCC Radar Type 5	Waveform 14	Completed	Yes
15	5303	FCC Radar Type 5	Waveform 15	Completed	Yes
16	5286	FCC Radar Type 5	Waveform 16	Completed	Yes
17	5288	FCC Radar Type 5	Waveform 17	Completed	Yes
18	5274	FCC Radar Type 5	Waveform 18	Completed	Yes
19	5275	FCC Radar Type 5	Waveform 19	Completed	Yes
20	5277	FCC Radar Type 5	Waveform 20	Completed	Yes
21	5279	FCC Radar Type 5	Waveform 21	Completed	Yes
22	5263	FCC Radar Type 5	Waveform 22	Completed	Yes
23	5288	FCC Radar Type 5	Waveform 23	Completed	Yes
24	5275	FCC Radar Type 5	Waveform 24	Completed	Yes
25	5289	FCC Radar Type 5	Waveform 25	Completed	Yes
26	5266	FCC Radar Type 5	Waveform 26	Completed	No
27	5285	FCC Radar Type 5	Waveform 27	Completed	Yes
28	5277	FCC Radar Type 5	Waveform 28	Completed	Yes
29	5288	FCC Radar Type 5	Waveform 29	Completed	Yes
30	5288	FCC Radar Type 5	Waveform 30	Completed	Yes
Occupied BW: 17.741MHz, 80%*17.741=14.192MHz, The frequency range from 5293MHz to 5307MHz					
Detection Probability Rate %:96.7					

**Note: Per 905462 D02 UNII DFS Compliance Procedures New Rules v02. The center frequency for each of the 30 trials of the Bin 5 radar shall be randomly selected within 80% of the Occupied Bandwidth.**

**Test Result-5290MHz – 80MHz**

<b>Trials</b>	<b>Frequency (MHz)</b>	<b>Radar Type</b>	<b>Waveform Type</b>	<b>Status</b>	<b>Result</b>
1	5290	FCC Radar Type 6	Waveform 1	Completed	Yes
2	5290	FCC Radar Type 6	Waveform 2	Completed	Yes
3	5290	FCC Radar Type 6	Waveform 3	Completed	Yes
4	5290	FCC Radar Type 6	Waveform 4	Completed	Yes
5	5290	FCC Radar Type 6	Waveform 5	Completed	Yes
6	5290	FCC Radar Type 6	Waveform 6	Completed	Yes
7	5290	FCC Radar Type 6	Waveform 7	Completed	Yes
8	5290	FCC Radar Type 6	Waveform 8	Completed	Yes
9	5290	FCC Radar Type 6	Waveform 9	Completed	Yes
10	5290	FCC Radar Type 6	Waveform 10	Completed	Yes
11	5290	FCC Radar Type 6	Waveform 11	Completed	Yes
12	5290	FCC Radar Type 6	Waveform 12	Completed	Yes
13	5290	FCC Radar Type 6	Waveform 13	Completed	Yes
14	5290	FCC Radar Type 6	Waveform 14	Completed	Yes
15	5290	FCC Radar Type 6	Waveform 15	Completed	Yes
16	5290	FCC Radar Type 6	Waveform 16	Completed	Yes
17	5290	FCC Radar Type 6	Waveform 17	Completed	Yes
18	5290	FCC Radar Type 6	Waveform 18	Completed	Yes
19	5290	FCC Radar Type 6	Waveform 19	Completed	Yes
20	5290	FCC Radar Type 6	Waveform 20	Completed	Yes
21	5290	FCC Radar Type 6	Waveform 21	Completed	Yes
22	5290	FCC Radar Type 6	Waveform 22	Completed	Yes
23	5290	FCC Radar Type 6	Waveform 23	Completed	Yes
24	5290	FCC Radar Type 6	Waveform 24	Completed	Yes
25	5290	FCC Radar Type 6	Waveform 25	Completed	Yes
26	5290	FCC Radar Type 6	Waveform 26	Completed	Yes
27	5290	FCC Radar Type 6	Waveform 27	Completed	Yes
28	5290	FCC Radar Type 6	Waveform 28	Completed	Yes
29	5290	FCC Radar Type 6	Waveform 29	Completed	Yes
30	5290	FCC Radar Type 6	Waveform 30	Completed	Yes
Detection Probability Rate %:					100.00

**Test Result-5530MHz – 80MHz**

<b>Trials</b>	<b>Frequency (MHz)</b>	<b>Radar Type</b>	<b>Waveform Type</b>	<b>Status</b>	<b>Result</b>
1	5530	FCC Radar Type 1	Waveform 1	Completed	Yes
2	5530	FCC Radar Type 1	Waveform 2	Completed	Yes
3	5530	FCC Radar Type 1	Waveform 3	Completed	Yes
4	5530	FCC Radar Type 1	Waveform 4	Completed	Yes
5	5530	FCC Radar Type 1	Waveform 5	Completed	Yes
6	5530	FCC Radar Type 1	Waveform 6	Completed	Yes
7	5530	FCC Radar Type 1	Waveform 7	Completed	Yes
8	5530	FCC Radar Type 1	Waveform 8	Completed	Yes
9	5530	FCC Radar Type 1	Waveform 9	Completed	No
10	5530	FCC Radar Type 1	Waveform 10	Completed	Yes
11	5530	FCC Radar Type 1	Waveform 11	Completed	Yes
12	5530	FCC Radar Type 1	Waveform 12	Completed	Yes
13	5530	FCC Radar Type 1	Waveform 13	Completed	Yes
14	5530	FCC Radar Type 1	Waveform 14	Completed	Yes
15	5530	FCC Radar Type 1	Waveform 15	Completed	Yes
16	5530	FCC Radar Type 1	Waveform 16	Completed	Yes
17	5530	FCC Radar Type 1	Waveform 17	Completed	Yes
18	5530	FCC Radar Type 1	Waveform 18	Completed	Yes
19	5530	FCC Radar Type 1	Waveform 19	Completed	Yes
20	5530	FCC Radar Type 1	Waveform 20	Completed	Yes
21	5530	FCC Radar Type 1	Waveform 21	Completed	Yes
22	5530	FCC Radar Type 1	Waveform 22	Completed	Yes
23	5530	FCC Radar Type 1	Waveform 23	Completed	Yes
24	5530	FCC Radar Type 1	Waveform 24	Completed	Yes
25	5530	FCC Radar Type 1	Waveform 25	Completed	Yes
26	5530	FCC Radar Type 1	Waveform 26	Completed	Yes
27	5530	FCC Radar Type 1	Waveform 27	Completed	Yes
28	5530	FCC Radar Type 1	Waveform 28	Completed	Yes
29	5530	FCC Radar Type 1	Waveform 29	Completed	Yes
30	5530	FCC Radar Type 1	Waveform 30	Completed	Yes

Detection Probability Rate %: 96.67

**Test Result-5530MHz – 80MHz**

<b>Trials</b>	<b>Frequency (MHz)</b>	<b>Radar Type</b>	<b>Waveform Type</b>	<b>Status</b>	<b>Result</b>
1	5530	FCC Radar Type 2	Waveform 1	Completed	Yes
2	5530	FCC Radar Type 2	Waveform 2	Completed	Yes
3	5530	FCC Radar Type 2	Waveform 3	Completed	Yes
4	5530	FCC Radar Type 2	Waveform 4	Completed	Yes
5	5530	FCC Radar Type 2	Waveform 5	Completed	NO
6	5530	FCC Radar Type 2	Waveform 6	Completed	Yes
7	5530	FCC Radar Type 2	Waveform 7	Completed	Yes
8	5530	FCC Radar Type 2	Waveform 8	Completed	Yes
9	5530	FCC Radar Type 2	Waveform 9	Completed	Yes
10	5530	FCC Radar Type 2	Waveform 10	Completed	Yes
11	5530	FCC Radar Type 2	Waveform 11	Completed	Yes
12	5530	FCC Radar Type 2	Waveform 12	Completed	Yes
13	5530	FCC Radar Type 2	Waveform 13	Completed	Yes
14	5530	FCC Radar Type 2	Waveform 14	Completed	Yes
15	5530	FCC Radar Type 2	Waveform 15	Completed	Yes
16	5530	FCC Radar Type 2	Waveform 16	Completed	Yes
17	5530	FCC Radar Type 2	Waveform 17	Completed	Yes
18	5530	FCC Radar Type 2	Waveform 18	Completed	Yes
19	5530	FCC Radar Type 2	Waveform 19	Completed	NO
20	5530	FCC Radar Type 2	Waveform 20	Completed	Yes
21	5530	FCC Radar Type 2	Waveform 21	Completed	Yes
22	5530	FCC Radar Type 2	Waveform 22	Completed	Yes
23	5530	FCC Radar Type 2	Waveform 23	Completed	Yes
24	5530	FCC Radar Type 2	Waveform 24	Completed	Yes
25	5530	FCC Radar Type 2	Waveform 25	Completed	Yes
26	5530	FCC Radar Type 2	Waveform 26	Completed	Yes
27	5530	FCC Radar Type 2	Waveform 27	Completed	Yes
28	5530	FCC Radar Type 2	Waveform 28	Completed	Yes
29	5530	FCC Radar Type 2	Waveform 29	Completed	Yes
30	5530	FCC Radar Type 2	Waveform 30	Completed	Yes

Detection Probability Rate %: 93.33

**Test Result-5530MHz – 80MHz**

<b>Trials</b>	<b>Frequency (MHz)</b>	<b>Radar Type</b>	<b>Waveform Type</b>	<b>Status</b>	<b>Result</b>
1	5530	FCC Radar Type 3	Waveform 1	Completed	Yes
2	5530	FCC Radar Type 3	Waveform 2	Completed	Yes
3	5530	FCC Radar Type 3	Waveform 3	Completed	Yes
4	5530	FCC Radar Type 3	Waveform 4	Completed	Yes
5	5530	FCC Radar Type 3	Waveform 5	Completed	Yes
6	5530	FCC Radar Type 3	Waveform 6	Completed	Yes
7	5530	FCC Radar Type 3	Waveform 7	Completed	Yes
8	5530	FCC Radar Type 3	Waveform 8	Completed	Yes
9	5530	FCC Radar Type 3	Waveform 9	Completed	No
10	5530	FCC Radar Type 3	Waveform 10	Completed	Yes
11	5530	FCC Radar Type 3	Waveform 11	Completed	Yes
12	5530	FCC Radar Type 3	Waveform 12	Completed	Yes
13	5530	FCC Radar Type 3	Waveform 13	Completed	Yes
14	5530	FCC Radar Type 3	Waveform 14	Completed	Yes
15	5530	FCC Radar Type 3	Waveform 15	Completed	Yes
16	5530	FCC Radar Type 3	Waveform 16	Completed	Yes
17	5530	FCC Radar Type 3	Waveform 17	Completed	Yes
18	5530	FCC Radar Type 3	Waveform 18	Completed	Yes
19	5530	FCC Radar Type 3	Waveform 19	Completed	NO
20	5530	FCC Radar Type 3	Waveform 20	Completed	Yes
21	5530	FCC Radar Type 3	Waveform 21	Completed	Yes
22	5530	FCC Radar Type 3	Waveform 22	Completed	Yes
23	5530	FCC Radar Type 3	Waveform 23	Completed	Yes
24	5530	FCC Radar Type 3	Waveform 24	Completed	Yes
25	5530	FCC Radar Type 3	Waveform 25	Completed	Yes
26	5530	FCC Radar Type 3	Waveform 26	Completed	Yes
27	5530	FCC Radar Type 3	Waveform 27	Completed	Yes
28	5530	FCC Radar Type 3	Waveform 28	Completed	NO
29	5530	FCC Radar Type 3	Waveform 29	Completed	Yes
30	5530	FCC Radar Type 3	Waveform 30	Completed	Yes
Detection Probability Rate %:					90

**Test Result-5530MHz – 80MHz**

<b>Trials</b>	<b>Frequency (MHz)</b>	<b>Radar Type</b>	<b>Waveform Type</b>	<b>Status</b>	<b>Result</b>
1	5530	FCC Radar Type 4	Waveform 1	Completed	Yes
2	5530	FCC Radar Type 4	Waveform 2	Completed	Yes
3	5530	FCC Radar Type 4	Waveform 3	Completed	Yes
4	5530	FCC Radar Type 4	Waveform 4	Completed	Yes
5	5530	FCC Radar Type 4	Waveform 5	Completed	Yes
6	5530	FCC Radar Type 4	Waveform 6	Completed	Yes
7	5530	FCC Radar Type 4	Waveform 7	Completed	Yes
8	5530	FCC Radar Type 4	Waveform 8	Completed	Yes
9	5530	FCC Radar Type 4	Waveform 9	Completed	Yes
10	5530	FCC Radar Type 4	Waveform 10	Completed	Yes
11	5530	FCC Radar Type 4	Waveform 11	Completed	Yes
12	5530	FCC Radar Type 4	Waveform 12	Completed	Yes
13	5530	FCC Radar Type 4	Waveform 13	Completed	Yes
14	5530	FCC Radar Type 4	Waveform 14	Completed	Yes
15	5530	FCC Radar Type 4	Waveform 15	Completed	Yes
16	5530	FCC Radar Type 4	Waveform 16	Completed	NO
17	5530	FCC Radar Type 4	Waveform 17	Completed	Yes
18	5530	FCC Radar Type 4	Waveform 18	Completed	Yes
19	5530	FCC Radar Type 4	Waveform 19	Completed	Yes
20	5530	FCC Radar Type 4	Waveform 20	Completed	Yes
21	5530	FCC Radar Type 4	Waveform 21	Completed	Yes
22	5530	FCC Radar Type 4	Waveform 22	Completed	Yes
23	5530	FCC Radar Type 4	Waveform 23	Completed	Yes
24	5530	FCC Radar Type 4	Waveform 24	Completed	Yes
25	5530	FCC Radar Type 4	Waveform 25	Completed	Yes
26	5530	FCC Radar Type 4	Waveform 26	Completed	Yes
27	5530	FCC Radar Type 4	Waveform 27	Completed	Yes
28	5530	FCC Radar Type 4	Waveform 28	Completed	Yes
29	5530	FCC Radar Type 4	Waveform 29	Completed	Yes
30	5530	FCC Radar Type 4	Waveform 30	Completed	Yes

Detection Probability Rate %: 96.67

**Test Result-5530MHz – 80MHz**

<b>Trials</b>	<b>Frequency (MHz)</b>	<b>Radar Type</b>	<b>Waveform Type</b>	<b>Status</b>	<b>Result</b>
1	5550	FCC Radar Type 5	Waveform 1	Completed	Yes
2	5533	FCC Radar Type 5	Waveform 2	Completed	Yes
3	5534	FCC Radar Type 5	Waveform 3	Completed	Yes
4	5555	FCC Radar Type 5	Waveform 4	Completed	Yes
5	5540	FCC Radar Type 5	Waveform 5	Completed	Yes
6	5558	FCC Radar Type 5	Waveform 6	Completed	Yes
7	5544	FCC Radar Type 5	Waveform 7	Completed	Yes
8	5555	FCC Radar Type 5	Waveform 8	Completed	Yes
9	5555	FCC Radar Type 5	Waveform 9	Completed	Yes
10	5548	FCC Radar Type 5	Waveform 10	Completed	Yes
11	5559	FCC Radar Type 5	Waveform 11	Completed	Yes
12	5550	FCC Radar Type 5	Waveform 12	Completed	Yes
13	5552	FCC Radar Type 5	Waveform 13	Completed	Yes
14	5532	FCC Radar Type 5	Waveform 14	Completed	Yes
15	5539	FCC Radar Type 5	Waveform 15	Completed	Yes
16	5516	FCC Radar Type 5	Waveform 16	Completed	Yes
17	5505	FCC Radar Type 5	Waveform 17	Completed	Yes
18	5504	FCC Radar Type 5	Waveform 18	Completed	Yes
19	5527	FCC Radar Type 5	Waveform 19	Completed	Yes
20	5515	FCC Radar Type 5	Waveform 20	Completed	Yes
21	5519	FCC Radar Type 5	Waveform 21	Completed	Yes
22	5521	FCC Radar Type 5	Waveform 22	Completed	Yes
23	5510	FCC Radar Type 5	Waveform 23	Completed	Yes
24	5511	FCC Radar Type 5	Waveform 24	Completed	Yes
25	5503	FCC Radar Type 5	Waveform 25	Completed	Yes
26	5504	FCC Radar Type 5	Waveform 26	Completed	Yes
27	5529	FCC Radar Type 5	Waveform 27	Completed	Yes
28	5517	FCC Radar Type 5	Waveform 28	Completed	Yes
29	5521	FCC Radar Type 5	Waveform 29	Completed	Yes
30	5521	FCC Radar Type 5	Waveform 30	Completed	Yes
Occupied BW: 75.561MHz, 80%*75.561=60.496MHz, The frequency range from 5500MHz to 5560MHz					
Detection Probability Rate %: 100					

**Note: Per 905462 D02 UNII DFS Compliance Procedures New Rules v02r02. The center frequency for each of the 30 trials of the Bin 5 radar shall be randomly selected within 80% of the Occupied Bandwidth.**

**Test Result-5530MHz – 80MHz**

<b>Trials</b>	<b>Frequency (MHz)</b>	<b>Radar Type</b>	<b>Waveform Type</b>	<b>Status</b>	<b>Result</b>
1	5530	FCC Radar Type 6	Waveform 1	Completed	Yes
2	5530	FCC Radar Type 6	Waveform 2	Completed	Yes
3	5530	FCC Radar Type 6	Waveform 3	Completed	Yes
4	5530	FCC Radar Type 6	Waveform 4	Completed	Yes
5	5530	FCC Radar Type 6	Waveform 5	Completed	Yes
6	5530	FCC Radar Type 6	Waveform 6	Completed	Yes
7	5530	FCC Radar Type 6	Waveform 7	Completed	Yes
8	5530	FCC Radar Type 6	Waveform 8	Completed	Yes
9	5530	FCC Radar Type 6	Waveform 9	Completed	Yes
10	5530	FCC Radar Type 6	Waveform 10	Completed	Yes
11	5530	FCC Radar Type 6	Waveform 11	Completed	Yes
12	5530	FCC Radar Type 6	Waveform 12	Completed	Yes
13	5530	FCC Radar Type 6	Waveform 13	Completed	Yes
14	5530	FCC Radar Type 6	Waveform 14	Completed	Yes
15	5530	FCC Radar Type 6	Waveform 15	Completed	Yes
16	5530	FCC Radar Type 6	Waveform 16	Completed	Yes
17	5530	FCC Radar Type 6	Waveform 17	Completed	Yes
18	5530	FCC Radar Type 6	Waveform 18	Completed	Yes
19	5530	FCC Radar Type 6	Waveform 19	Completed	Yes
20	5530	FCC Radar Type 6	Waveform 20	Completed	Yes
21	5530	FCC Radar Type 6	Waveform 21	Completed	Yes
22	5530	FCC Radar Type 6	Waveform 22	Completed	Yes
23	5530	FCC Radar Type 6	Waveform 23	Completed	Yes
24	5530	FCC Radar Type 6	Waveform 24	Completed	Yes
25	5530	FCC Radar Type 6	Waveform 25	Completed	Yes
26	5530	FCC Radar Type 6	Waveform 26	Completed	Yes
27	5530	FCC Radar Type 6	Waveform 27	Completed	Yes
28	5530	FCC Radar Type 6	Waveform 28	Completed	Yes
29	5530	FCC Radar Type 6	Waveform 29	Completed	Yes
30	5530	FCC Radar Type 6	Waveform 30	Completed	Yes

Detection Probability Rate %: 100.00

## Annex A. TEST INSTRUMENT

Instrument	Model	Serial #	Cal Date	Cal Due	In use
<b>Radiated DFS Measurement</b>					
Keysight Signal Analyzer	N9020A	MY49100060	11/16/2015	11/15/2016	<input checked="" type="checkbox"/>
Splitter/Combiner (Mini-Circuit)	PD-2/8-2S	XA022154	11/16/2015	11/15/2016	<input checked="" type="checkbox"/>
Splitter/Combiner (Mini-Circuit)	PD-2/8-2S	XA022155	11/16/2015	11/15/2016	<input checked="" type="checkbox"/>
Splitter/Combiner (Mini-Circuit)	PD-2/8-2S	XA022159	11/16/2015	11/15/2016	<input checked="" type="checkbox"/>
Agilent Signal Generator	MXG N5182A	MY50140530	11/18/2015	11/17/2016	<input checked="" type="checkbox"/>

**Annex C. iI. SUPPORTING EQUIPMENT DESCRIPTION**

The following is a description of supporting equipment and details of cables used with the EUT.

<b>Manufacturer</b>	<b>Equipment Description</b>	<b>Model</b>	<b>Serial No</b>
USB Wireless Adaptor	Adapter	WUSB6300	CX12503647
Lenovo	Laptop	E40	13E10S0A303087

Test Report No.	16040115-FCC-R3
Page	77 of 78

**Annex D. User Manual / Block Diagram / Schematics / Partlist**

Please see attachment

Test Report No.	16040115-FCC-R3
Page	78 of 78

## Annex E. DECLARATION OF SIMILARITY