



# RADIO TEST REPORT

## Test Report No. 14206465H-B-R2

<b>Customer</b>	<b>Panasonic Corporation of North America</b>
<b>Description of EUT</b>	<b>Radio Module (Tested inside of Panasonic Personal Computer FZ-G2)</b>
<b>Model Number of EUT</b>	<b>WW22A</b>
<b>FCC ID</b>	<b>ACJ9TGWW22A</b>
<b>Test Regulation</b>	<b>FCC Part 96</b>
<b>Test Result</b>	<b>Complied (Refer to SECTION 3)</b>
<b>Issue Date</b>	<b>December 9, 2022</b>
<b>Remarks</b>	<b>Spurious Emission (Radiated) test only</b>

**Representative Test Engineer**

Junya Okuno  
Engineer

**Approved By**

Takayuki Shimada  
Leader



CERTIFICATE 5107.02

- The testing in which "Non-accreditation" is displayed is outside the accreditation scopes in UL Japan, Inc.  
 There is no testing item of "Non-accreditation".

## ANNOUNCEMENT

- This test report shall not be reproduced in full or partial, without the written approval of UL Japan, Inc.
- The results in this report apply only to the sample tested.
- This sample tested is in compliance with the limits of the above regulation.
- The test results in this test report are traceable to the national or international standards.
- This test report must not be used by the customer to claim product certification, approval, or endorsement by the A2LA accreditation body.
- This test report covers Radio technical requirements.  
It does not cover administrative issues such as Manual or non-Radio test related Requirements. (if applicable)
- The all test items in this test report are conducted by UL Japan, Inc Ise EMC Lab.
- The opinions and the interpretations to the result of the description in this report are outside scopes where UL Japan, Inc. has been accredited.
- The information provided from the applicant for this report is identified in Section 1.
- For test report(s) referred in this report, the latest version (including any revisions) is always referred.

## REVISION HISTORY

### Original Test Report No.: 14206465H-B

This report is a revised version of 14206465H-B-R1. 14206465H-B-R1 is replaced with this report.

Revision	Test Report No.	Date	Page Revised Contents
- (Original)	14206465H-B	June 16, 2022	-
1	14206465H-B-R1	December 2, 2022	<u>Relevant page</u> Deleted the information about FCC Part 27 and data for LTE Band 42.
1	14206465H-B-R1	December 2, 2022	<u>Clause 4.1</u> Deleted Table for LTE Band 42 and added note "LTE Band 42 (3550-3600 MHz) is covered by LTE Band 48 (3550-3700 MHz)."
1	14206465H-B-R1	December 2, 2022	<u>APPENDIX 2</u> Removed test instruments related to the deleted data.
2	14206465H-B-R2	December 9, 2022	<u>APPENDIX 1 (P.16, 17)</u> Added Reference Plot data for Spurious Emission (Radiated).

**Reference: Abbreviations (Including words undescribed in this report)**

A2LA	The American Association for Laboratory Accreditation	ICES	Interference-Causing Equipment Standard
AC	Alternating Current	IEC	International Electrotechnical Commission
AFH	Adaptive Frequency Hopping	IEEE	Institute of Electrical and Electronics Engineers
AM	Amplitude Modulation	IF	Intermediate Frequency
Amp, AMP	Amplifier	ILAC	International Laboratory Accreditation Conference
ANSI	American National Standards Institute	ISED	Innovation, Science and Economic Development Canada
Ant, ANT	Antenna	ISO	International Organization for Standardization
AP	Access Point	JAB	Japan Accreditation Board
ASK	Amplitude Shift Keying	LAN	Local Area Network
Atten., ATT	Attenuator	LIMS	Laboratory Information Management System
AV	Average	MCS	Modulation and Coding Scheme
BPSK	Binary Phase-Shift Keying	MRA	Mutual Recognition Arrangement
BR	Bluetooth Basic Rate	N/A	Not Applicable
BT	Bluetooth	NIST	National Institute of Standards and Technology
BT LE	Bluetooth Low Energy	NS	No signal detect.
BW	BandWidth	NSA	Normalized Site Attenuation
Cal Int	Calibration Interval	NVLAP	National Voluntary Laboratory Accreditation Program
CCK	Complementary Code Keying	OBW	Occupied Band Width
Ch., CH	Channel	OFDM	Orthogonal Frequency Division Multiplexing
CISPR	Comite International Special des Perturbations Radioelectriques	P/M	Power meter
CW	Continuous Wave	PCB	Printed Circuit Board
DBPSK	Differential BPSK	PER	Packet Error Rate
DC	Direct Current	PHY	Physical Layer
D-factor	Distance factor	PK	Peak
DFS	Dynamic Frequency Selection	PN	Pseudo random Noise
DQPSK	Differential QPSK	PRBS	Pseudo-Random Bit Sequence
DSSS	Direct Sequence Spread Spectrum	PSD	Power Spectral Density
EDR	Enhanced Data Rate	QAM	Quadrature Amplitude Modulation
EIRP, e.i.r.p.	Equivalent Isotropically Radiated Power	QP	Quasi-Peak
EMC	ElectroMagnetic Compatibility	QPSK	Quadri-Phase Shift Keying
EMI	ElectroMagnetic Interference	RBW	Resolution Band Width
EN	European Norm	RDS	Radio Data System
ERP, e.r.p.	Effective Radiated Power	RE	Radio Equipment
EU	European Union	RF	Radio Frequency
EUT	Equipment Under Test	RMS	Root Mean Square
Fac.	Factor	RSS	Radio Standards Specifications
FCC	Federal Communications Commission	Rx	Receiving
FHSS	Frequency Hopping Spread Spectrum	SA, S/A	Spectrum Analyzer
FM	Frequency Modulation	SG	Signal Generator
Freq.	Frequency	SVSWR	Site-Voltage Standing Wave Ratio
FSK	Frequency Shift Keying	TR	Test Receiver
GFSK	Gaussian Frequency-Shift Keying	Tx	Transmitting
GNSS	Global Navigation Satellite System	VBW	Video BandWidth
GPS	Global Positioning System	Vert.	Vertical
Hori.	Horizontal	WLAN	Wireless LAN

<b>CONTENTS</b>	<b>PAGE</b>
<b>SECTION 1: Customer information .....</b>	<b>5</b>
<b>SECTION 2: Equipment under test (EUT) .....</b>	<b>5</b>
<b>SECTION 3: Test specification, procedures &amp; results .....</b>	<b>7</b>
<b>SECTION 4: Operation of EUT during testing.....</b>	<b>9</b>
<b>SECTION 5: Spurious Emission (Radiated) .....</b>	<b>11</b>
<b>APPENDIX 1: Test data.....</b>	<b>13</b>
Spurious Emission (Radiated).....	13
<b>APPENDIX 2: Test instruments .....</b>	<b>18</b>
<b>APPENDIX 3: Photographs of test setup.....</b>	<b>19</b>
Spurious Emission (Radiated).....	19
Worst Case Position .....	20

## **SECTION 1: Customer information**

Company Name	Panasonic Corporation of North America
Address	Two Riverfront Plaza, 9th Floor Newark, NEW JERSEY, 07102-5940, USA
Telephone Number	+1-201-348-7760
Contact Person	Ben Botros

**\*Remarks:**

Panasonic Connect Co., Ltd. is on behalf of the applicant: Panasonic Corporation of North America (Company incorporated abroad).

The information provided from the customer is as follows;

- Customer, Description of EUT, Model Number of EUT, FCC ID on the cover and other relevant pages
- Operating/Test Mode(s) (Mode(s)) on all the relevant pages
- SECTION 1: Customer Information
- SECTION 2: Equipment Under Test (EUT) other than the Receipt Date and Test Date
- SECTION 4: Operation of EUT during testing

\* The laboratory is exempted from liability of any test results affected from the above information in SECTION 2 and 4.

## **SECTION 2: Equipment under test (EUT)**

### **2.1 Identification of EUT**

Description	Radio Module
Model Number	WW22A
Serial Number	Refer to SECTION 4.2
Condition	Engineering prototype (Not for Sale: This sample is equivalent to mass-produced items.)
Modification	No Modification by the test lab
Receipt Date	March 8, 2022
Test Date	March 30 to May 24, 2022

<Information of Host device>

Type	Personal Computer FZ-G2 Intel Core i7 processor (1.1 GHz Max 4.9 GHz) 10.1 inch LCD (1920 x 1200)
------	---

## 2.2 Product Description

### General Specification

Rating	DC 3.0 V to 3.6 V
Operating temperature	-10 deg. C to 50 deg. C

### Radio Specification

Wireless technologies	Dup.	Band	Mode
WCDMA	FDD		2 UMTS Rel. 99 (Data) HSDPA (Rel. 5)
	FDD		4 HSUPA (Rel. 6), HSPA+ (Rel. 7), DC-HSDPA (Rel. 8)
	FDD		5
LTE  *B14, B41, B48: not used in Canada (ISED)	FDD		2 QPSK, 16QAM, 64AQM, 256QAM
	FDD		4
	FDD		5
	FDD		7
	FDD		12
	FDD		13
	FDD		14
	FDD		17
	FDD		25
	FDD		26
	FDD(Rx only)		29
	FDD(Rx only)		32
	TDD		38
	TDD		41
	TDD		42
	TDD(Rx only)		46
TDD		48	
FDD		66	
LTE CA	Downlink		Uplink
	Maximum 5 carriers		*B42: not used in US (FCC) / B48: not used in Canada(ISED) Maximum 2 carriers Supported combination: <Intra-band contiguous> 5B, 7C, 38C, 41C, 42C

\*This test report applies to LTE Band 42 and Band 48 parts only.

### **SECTION 3: Test specification, procedures & results**

#### **3.1 Test Specification**

Test Specification	FCC Part 96 final revised on May 1, 2020
Title	FCC 47CFR PART 96 CITIZENS BROADBAND RADIO SERVICE

#### **3.2 Procedures and results**

Item	Test Specification & Procedure	Worst margin	Results	Remarks
Spurious Emission (Radiated)	FCC 2.1053 FCC 96.41(e)	11.98 dB 7197.800 MHz Vertical, AV	Complied a)	Radiated
<p>Note: UL Japan's EMI Work Procedures: Work Instructions-ULID-003591            *These tests were also referred to:            ANSI/C63.26:2015, ANSI/TIA-603-E-2016, KDB 971168 D01 v03r01, KDB 971168 D02 v02r01 and            KDB 940660 D01 v03.</p> <p>*These tests were performed without any deviations from test procedure except for additions or exclusions.</p> <p>a) Refer to APPENDIX 1 (Spurious Emission (Radiated))</p> <p>Symbols:            Complied The data of this test item has enough margin, more than the measurement uncertainty.            Complied# The data of this test item meets the limits unless the measurement uncertainty is taken into consideration.</p>				

#### **3.3 Addition to standard**

No addition, exclusion nor deviation has been made from the standard.

#### **3.4 Uncertainty**

There is no applicable rule of uncertainty in this applied standard. Therefore, the results are derived depending on whether or not laboratory uncertainty is applied.

The following uncertainties have been calculated to provide a confidence level of 95 % using a coverage factor k=2.

##### **Radiated emission**

Measurement distance	Frequency range		Uncertainty (+/-)
3 m	9 kHz to 30 MHz		3.2 dB
10 m			3.0 dB
3 m	30 MHz to 200 MHz	Horizontal	4.8 dB
		Vertical	5.0 dB
	200 MHz to 1000 MHz	Horizontal	5.1 dB
		Vertical	6.2 dB
10 m	30 MHz to 200 MHz	Horizontal	4.8 dB
		Vertical	4.8 dB
	200 MHz to 1000 MHz	Horizontal	5.0 dB
		Vertical	5.0 dB
3 m	1 GHz to 6 GHz		4.9 dB
	6 GHz to 18 GHz		5.2 dB
1 m	10 GHz to 26.5 GHz		5.4 dB
	26.5 GHz to 40 GHz		5.4 dB
10 m	1 GHz to 18 GHz		5.4 dB

### 3.5 Test Location

UL Japan, Inc. Ise EMC Lab.

\*A2LA Certificate Number: 5107.02 / FCC Test Firm Registration Number: 884919

ISED Lab Company Number: 2973C / CAB identifier: JP0002

4383-326 Asama-cho, Ise-shi, Mie-ken 516-0021 Japan

Telephone: +81-596-24-8999

Test site	Width x Depth x Height (m)	Size of reference ground plane (m) / horizontal conducting plane	Other rooms	Maximum measurement distance
No.1 semi-anechoic chamber	19.2 x 11.2 x 7.7	7.0 x 6.0	No.1 Power source room	10 m
No.2 semi-anechoic chamber	7.5 x 5.8 x 5.2	4.0 x 4.0	-	3 m
No.3 semi-anechoic chamber	12.0 x 8.5 x 5.9	6.8 x 5.75	No.3 Preparation room	3 m
No.3 shielded room	4.0 x 6.0 x 2.7	N/A	-	-
No.4 semi-anechoic chamber	12.0 x 8.5 x 5.9	6.8 x 5.75	No.4 Preparation room	3 m
No.4 shielded room	4.0 x 6.0 x 2.7	N/A	-	-
No.5 semi-anechoic chamber	6.0 x 6.0 x 3.9	6.0 x 6.0	-	-
No.5 measurement room	6.4 x 6.4 x 3.0	6.4 x 6.4	-	-
No.6 shielded room	4.0 x 4.5 x 2.7	4.0 x 4.5	-	-
No.6 measurement room	4.75 x 5.4 x 3.0	4.75 x 4.15	-	-
No.7 shielded room	4.7 x 7.5 x 2.7	4.7 x 7.5	-	-
No.8 measurement room	3.1 x 5.0 x 2.7	3.1 x 5.0	-	-
No.9 measurement room	8.8 x 4.6 x 2.8	2.4 x 2.4	-	-
No.10 shielded room	3.8 x 2.8 x 2.8	3.8 x 2.8	-	-
No.11 measurement room	4.0 x 3.4 x 2.5	N/A	-	-
No.12 measurement room	2.6 x 3.4 x 2.5	N/A	-	-
Large Chamber	16.9 x 22.1 x 10.17	16.9 x 22.1	-	10 m
Small Chamber	5.3 x 6.69 x 3.59	5.3 x 6.69	-	-

\* Size of vertical conducting plane (for Conducted Emission test) : 2.0 x 2.0 m for No.1, No.2, No.3, and No.4 semi-anechoic chambers and No.3 and No.4 shielded rooms.

### 3.6 Test data, Test instruments, and Test set up

Refer to APPENDIX.



## **SECTION 4: Operation of EUT during testing**

### **4.1 Operating Mode(s)**

#### **<LTE Band 48>**

<b>Test</b>	<b>Operating mode</b>	<b>Power Control</b>	<b>Tested frequency</b>	<b>Uplink Channel</b>
Spurious Emission (Radiated)	Transmitting (Tx) LTE Band 48 (20 MHz band) *1)	TPC All Up bits (Max)	3560 MHz 3625 MHz 3690 MHz	55340 55990 56640
*1) The test was performed on the worst mode according to the result of preliminary testing.				

\*Power of the EUT was set by the software as follows;

Power settings: All up bits

Software: T77W968.F1.0.0.5.3

\*This setting of software is the worst case.

Any conditions under the normal use do not exceed the condition of setting.

In addition, end users cannot change the settings of the output power of the product.

LTE Band 42 (3550-3600 MHz) is covered by LTE Band 48 (3550-3700 MHz).

## 4.2 Configuration and peripherals

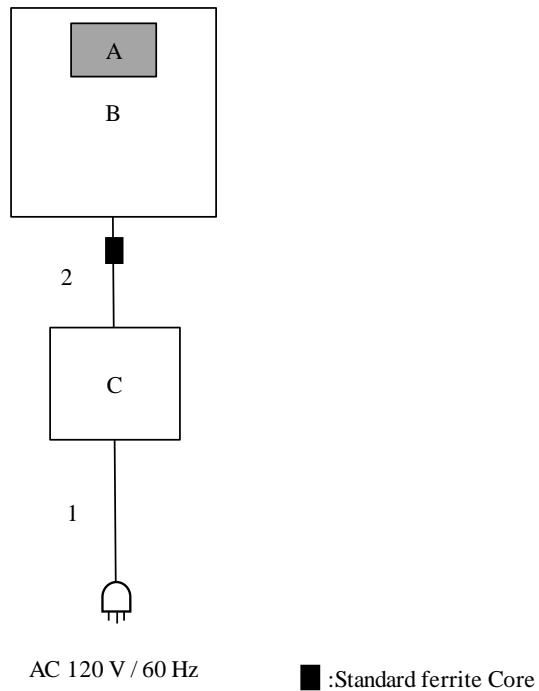

\* Cabling and setup(s) were taken into consideration and test data was taken under worse case conditions.

### Description of EUT and Support equipment

No.	Item	Model number	Serial number	Manufacturer	Remarks
A	Wireless Module	WW22A	*1)	Panasonic Connect Co., Ltd.	EUT
B	Personal Computer	FZ-G2	1JTSA76441	Panasonic Connect Co., Ltd.	-
C	AC Adaptor	CF-AA5713A M7	5713AM7217008383WB	Panasonic Connect Co., Ltd.	-

### List of cables used

No.	Name	Length (m)	Shield		Remarks
			Cable	Connector	
1	AC Cable	2.0	Unshielded	Unshielded	-
2	DC Cable	1.5	Unshielded	Unshielded	-

\*1) This item is controlled with B: Personal Computer.

## **SECTION 5: Spurious Emission (Radiated)**

[Radiated: Spurious Emission]

[For below 1 GHz]

EUT was placed on a urethane platform of nominal size, 0.5 m by 1.0 m, raised 0.8 m above the conducting ground plane. The Radiated Electric Field Strength has been measured in a Semi Anechoic Chamber with a ground plane.

[For above 1 GHz]

EUT was placed on a urethane platform of nominal size, 0.5 m by 0.5 m, raised 1.5 m above the conducting ground plane. The Radiated Electric Field Strength has been measured in a Semi Anechoic Chamber with absorbent materials lined on a ground plane.

The height of the measuring antenna varied between 1 m and 4 m and EUT was rotated a full revolution in order to obtain the maximum value of the electric field strength.

Test antenna was aimed at the EUT for receiving the maximum signal and always kept within the illumination area of the 3 dB beam width of the antenna.

The measurements were performed for both vertical and horizontal antenna polarization with the Test Receiver, or the Spectrum Analyzer.

**Test Antennas are used as below;**

Frequency	Below 30 MHz	30 MHz to 200 MHz	200 MHz to 1 GHz	Above 1 GHz
Antenna Type	Loop	Biconical	Logperiodic	Horn

- The carrier level and noise levels were confirmed at each position of X, Y and Z axes of EUT to see the position of maximum noise, and the test was made at the position that has the maximum noise.

Setting of the spectrum analyzer: below 1 GHz RBW 100 kHz VBW 300 kHz above 1 GHz RBW 1 MHz VBW 3 MHz

Figure 1: Test Setup

Below 1 GHz

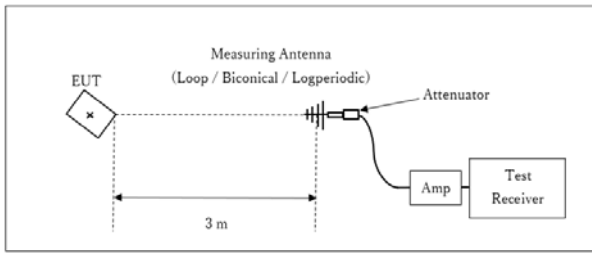

Test Distance: 3 m

1 GHz - 10 GHz

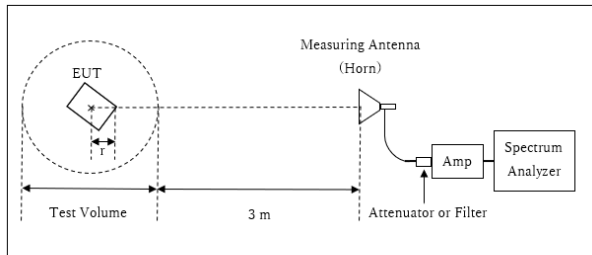

Distance Factor:  $20 \times \log(3.9 \text{ m} / 3.0 \text{ m}) = 2.29 \text{ dB}$   
\* Test Distance:  $(3 + \text{SVSWR Volume} / 2) - r = 3.90 \text{ m}$

SVSWR Volume : 2.0 m  
(SVSWR Volume has been calibrated based on CISPR 16-1-4.)  
r = 0.10 m

10 GHz - 40 GHz

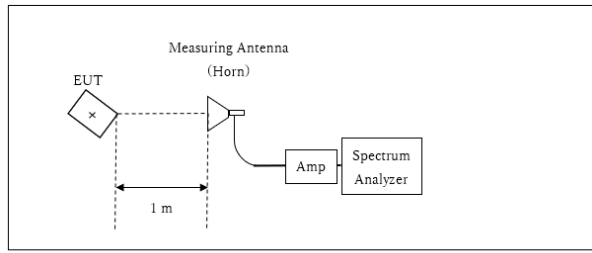

Test Distance: 1 m

The test results and limit are rounded off to one decimal place, so some differences might be observed.

Measurement range : 30 MHz - 40 GHz  
Test data : APPENDIX  
Test result : Pass

**APPENDIX 1: Test data**

**Spurious Emission (Radiated)**

Test place	Ise EMC Lab.
Semi Anechoic Chamber	No.3
Date	May 24, 2022
Temperature / Humidity	20 deg. C / 52 % RH
Engineer	Junya Okuno
Mode	LTE Band 48 3560 MHz, 20 MHz Band

For End User Device in the 3550-3700 MHz band

Polarity	Frequency [MHz]	Detector	Reading [dBuV]	Ant.Fac. [dB/m]	Loss [dB]	Gain [dB]	RBW Conversion Factor [dB]	Result [dBuV/m]	Distance [m]	EIRP [dBm]	ERP [dBm]	Limit [dBm]	Margin [dB]	Remark
Hori.	183.813	AV	21.00	16.39	9.01	32.06	10.00	24.34	3.00	-70.92	-73.07	-40.00	33.07	
Hori.	226.042	AV	23.65	11.90	9.39	32.04	10.00	22.90	3.00	-72.36	-74.51	-40.00	34.51	
Hori.	3275.905	AV	37.83	28.39	5.46	32.50	-	39.18	3.00	-56.08	-58.23	-40.00	18.23	
Hori.	3826.311	AV	40.27	29.57	5.75	32.29	-	43.30	3.00	-51.96	-54.11	-40.00	14.11	
Hori.	7120.000	AV	34.28	35.60	10.04	32.74	-	47.18	3.00	-48.08	-50.23	-40.00	10.23	Floor noise
Vert.	181.221	AV	20.45	16.35	8.98	32.07	10.00	23.71	3.00	-71.55	-73.70	-40.00	33.70	
Vert.	225.560	AV	30.37	11.89	9.39	32.04	10.00	29.61	3.00	-65.65	-67.80	-40.00	27.80	
Vert.	3275.905	AV	38.60	28.39	5.46	32.50	-	39.95	3.00	-55.31	-57.46	-40.00	17.46	
Vert.	3826.311	AV	41.12	29.57	5.75	32.29	-	44.15	3.00	-51.11	-53.26	-40.00	13.26	
Vert.	7120.000	AV	34.31	35.60	10.04	32.74	-	47.21	3.00	-48.05	-50.20	-40.00	10.20	Floor noise

Result (E) = Reading + Ant Factor + Loss (Cable+Attenuator+Filter+Distance factor(above 1 GHz)) - Gain(Amplifier) + RBW Conversion Factor(below 1 GHz)

EIRP = E + 20\*log(D) -104.8

ERP =EIRP -2.15

RBW Conversion Factor = 10\*log [1 MHz / (Measurement RBW)]

\*Other frequency noises omitted in this report were not seen or had enough margin (more than 20 dB).

Distance factor: 1 GHz - 10 GHz 20log (3.9 m / 3.0 m) = 2.28 dB

\*No signal was detected above 10 GHz.

### Spurious Emission (Radiated)

Test place	Ise EMC Lab.
Semi Anechoic Chamber	No.3
Date	May 24, 2022
Temperature / Humidity	20 deg. C / 52 % RH
Engineer	Junya Okuno
Mode	LTE Band 48 3625 MHz, 20 MHz Band

For End User Device in the 3550-3700 MHz band

Polarity	Frequency [MHz]	Detector	Reading [dBuV]	Ant.Fac. [dB/m]	Loss [dB]	Gain [dB]	RBW Conversion Factor [dB]	Result [dBuV/m]	Distance [m]	EIRP [dBm]	ERP [dBm]	Limit [dBm]	Margin [dB]	Remark
Hori.	183.372	AV	21.55	16.38	9.00	32.06	10.00	24.87	3.00	-70.39	-72.54	-40.00	32.54	
Hori.	227.440	AV	23.47	11.93	9.41	32.04	10.00	22.77	3.00	-72.49	-74.64	-40.00	34.64	
Hori.	3340.955	AV	38.24	28.30	5.50	32.48	-	39.56	3.00	-55.70	-57.85	-40.00	17.85	
Hori.	3891.314	AV	40.00	29.68	5.78	32.26	-	43.20	3.00	-52.06	-54.21	-40.00	14.21	
Hori.	7250.000	AV	33.98	35.78	10.01	32.79	-	46.98	3.00	-48.28	-50.43	-40.00	10.43	Floor noise
Vert.	182.556	AV	20.57	16.38	9.00	32.06	10.00	23.89	3.00	-71.37	-73.52	-40.00	33.52	
Vert.	226.962	AV	29.89	11.92	9.40	32.04	10.00	29.17	3.00	-66.09	-68.24	-40.00	28.24	
Vert.	3340.955	AV	38.45	28.30	5.50	32.48	-	39.77	3.00	-55.49	-57.64	-40.00	17.64	
Vert.	3891.314	AV	38.52	29.68	5.78	32.26	-	41.72	3.00	-53.54	-55.69	-40.00	15.69	
Vert.	7250.000	AV	34.04	35.78	10.01	32.79	-	47.04	3.00	-48.22	-50.37	-40.00	10.37	Floor noise

Result (E) = Reading + Ant Factor + Loss (Cable+Attenuator+Filter+Distance factor(above 1 GHz)) - Gain(Amplifier) + RBW Conversion Factor(below 1 GHz)

EIRP = E + 20\*log(D) -104.8

ERP =EIRP -2.15

RBW Conversion Factor = 10\*log [1 MHz / (Measurement RBW)]

\*Other frequency noises omitted in this report were not seen or had enough margin (more than 20 dB).

Distance factor: 1 GHz - 10 GHz 20log (3.9 m / 3.0 m) = 2.28 dB

\*No signal was detected above 10 GHz.

### Spurious Emission (Radiated)

Test place	Ise EMC Lab.
Semi Anechoic Chamber	No.3
Date	May 24, 2022
Temperature / Humidity	20 deg. C / 52 % RH
Engineer	Junya Okuno
Mode	LTE Band 48 3690 MHz, 20 MHz Band

For End User Device in the 3550-3700 MHz band

Polarity	Frequency	Detector	Reading	Ant.Fac.	Loss	Gain	RBW Conversion Factor	Result	Distance	EIRP	ERP	Limit	Margin	Remark
	[MHz]		[dBuV]	[dB/m]	[dB]	[dB]	[dB]	[dBuV/m]	[m]	[dBm]	[dBm]	[dBm]	[dB]	
Hori.	182.892	AV	21.84	16.38	9.00	32.06	10.00	25.16	3.00	-70.10	-72.25	-40.00	32.25	
Hori.	227.330	AV	23.34	11.93	9.41	32.04	10.00	22.64	3.00	-72.62	-74.77	-40.00	34.77	
Hori.	3405.911	AV	36.76	28.40	5.53	32.45	-	38.24	3.00	-57.02	-59.17	-40.00	19.17	
Hori.	3956.317	AV	36.70	29.78	5.82	32.24	-	40.06	3.00	-55.20	-57.35	-40.00	17.35	
Hori.	7380.000	AV	33.88	36.02	9.96	32.84	-	47.02	3.00	-48.24	-50.39	-40.00	10.39	Floor noise
Vert.	182.702	AV	20.54	16.38	9.00	32.06	10.00	23.86	3.00	-71.40	-73.55	-40.00	33.55	
Vert.	227.004	AV	29.62	11.92	9.40	32.04	10.00	28.90	3.00	-66.36	-68.51	-40.00	28.51	
Vert.	3405.911	AV	39.38	28.40	5.53	32.45	-	40.86	3.00	-54.40	-56.55	-40.00	16.55	
Vert.	3956.317	AV	36.92	29.78	5.82	32.24	-	40.28	3.00	-54.98	-57.13	-40.00	17.13	
Vert.	7380.000	AV	33.76	36.02	9.96	32.84	-	46.90	3.00	-48.36	-50.51	-40.00	10.51	Floor noise

Result (E) = Reading + Ant Factor + Loss (Cable+Attenuator+Filter+Distance factor(above 1 GHz)) - Gain(Amplifier) + RBW Conversion Factor(below 1 GHz)

EIRP = E + 20\*log(D) -104.8

ERP =EIRP -2.15

RBW Conversion Factor = 10\*log [1 MHz / (Measurement RBW)]

\*Other frequency noises omitted in this report were not seen or had enough margin (more than 20 dB).

Distance factor: 1 GHz - 10 GHz 20log (3.9 m / 3.0 m) = 2.28 dB

\*No signal was detected above 10 GHz.

**Spurious Emission (Radiated)**  
(Reference plot)

Test place	Ise EMC Lab.
Semi Anechoic Chamber	No.3
Date	May 24, 2022
Temperature / Humidity	20 deg. C / 52 % RH
Engineer	Junya Okuno
Mode	LTE Band 48 3560 MHz, 20 MHz Band

For End User Device in the 3550-3700 MHz band

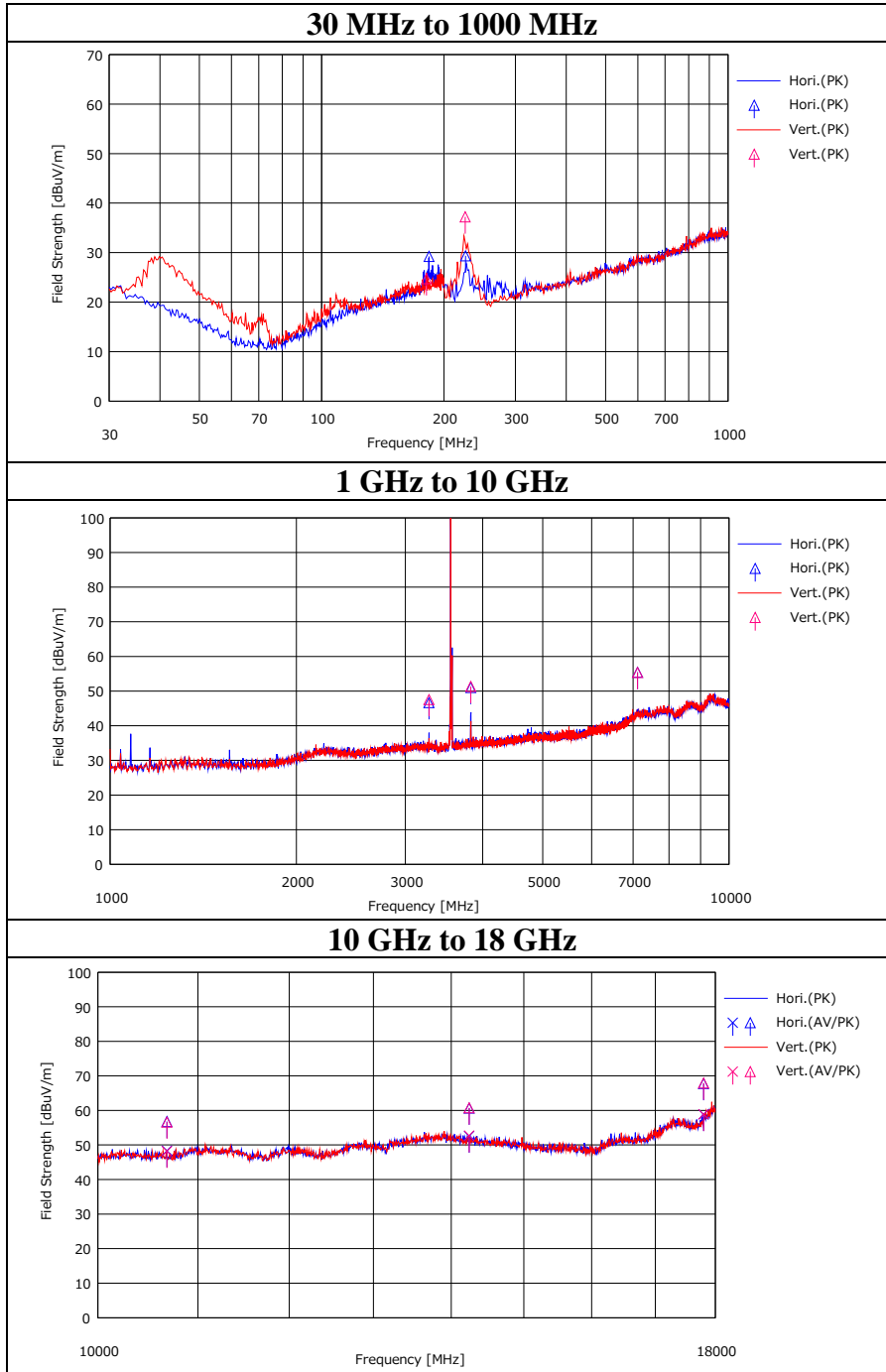



**Spurious Emission (Radiated)**  
(Reference plot)

Test place	Ise EMC Lab.
Semi Anechoic Chamber	No.3
Date	May 24, 2022
Temperature / Humidity	20 deg. C / 52 % RH
Engineer	Junya Okuno
Mode	LTE Band 48 3560 MHz, 20 MHz Band

For End User Device in the 3550-3700 MHz band

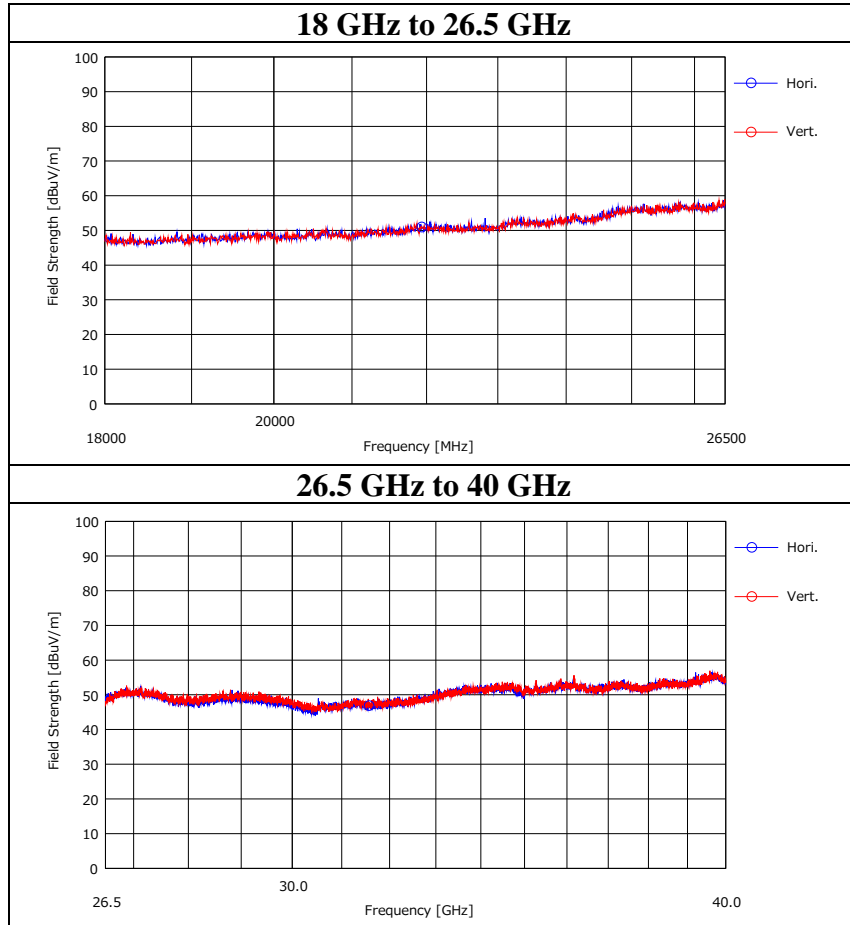

## APPENDIX 2: Test instruments

### Test equipment

Test Item	Local ID	LIMS ID	Description	Manufacturer	Model	Serial	Last Calibration Date	Cal Int
RE	COTS-MEMI-02	178648	EMI measurement program	TSJ (Techno Science Japan)	TEPTO-DV	-	-	-
RE	MAEC-03	142008	AC3_Semi Anechoic Chamber(NSA)	TDK	Semi Anechoic Chamber 3m	DA-10005	05/22/2020	24
RE	MAEC-03-SVSWR	142013	AC3_Semi Anechoic Chamber(SVSWR)	TDK	Semi Anechoic Chamber 3m	DA-10005	04/01/2021	24
RE	MAT-95	142314	Attenuator	Pasternack Enterprises	PE7390-6	D/C 1504	06/09/2021	12
RE	MBA-03	141424	Biconical Antenna	Schwarzbeck Mess-Elektronik OHG	VHA9103+BBA9106	1915	08/21/2021	12
RE	MCC-177	141226	Microwave Cable	Junkosha	MMX221-00500DMSDMS	1502S304	03/17/2022	12
RE	MCC-231	177964	Microwave Cable	Junkosha INC.	MMX221	1901S329(1m)/1902S579(5m)	03/15/2022	12
RE	MCC-51	141323	Coaxial cable	UL Japan	-	-	07/19/2021	12
RE	MCC-54	141325	Microwave Cable	Suhner	SUCOFLEX101	2873(1m) / 2876(5m)	03/17/2022	12
RE	MHA-16	141513	Horn Antenna 15-40GHz	Schwarzbeck Mess-Elektronik OHG	BBHA9170	BBHA9170306	06/07/2021	12
RE	MHA-20	141507	Horn Antenna 1-18GHz	Schwarzbeck Mess-Elektronik OHG	BBHA9120D	258	11/09/2021	12
RE	MHF-22	141293	High Pass Filter 7-20GHz	TOKIMEC	TF37NCCB	602	02/24/2022	12
RE	MJM-29	142230	Measure	KOMELON	KMC-36	-	-	-
RE	MLA-22	141266	Logperiodic Antenna(200-1000MHz)	Schwarzbeck Mess-Elektronik OHG	VUSLP9111B	9111B-191	08/21/2021	12
RE	MMM-08	141532	DIGITAL HiTESTER	HIOKI E.E. CORPORATION	3805	51201197	01/16/2022	12
RE	MOS-13	141554	Thermo-Hygrometer	CUSTOM. Inc	CTH-201	1301	01/10/2022	12
RE	MPA-11	141580	MicroWave System Amplifier	Keysight Technologies Inc	83017A	MY39500779	03/17/2022	12
RE	MPA-13	141582	Pre Amplifier	SONOMA INSTRUMENT	310	260834	02/25/2022	12
RE	MPA-22	141588	Pre Amplifier	MITEQ, Inc	AMF-6F-2600400-33-8P / AMF-4F-2600400-33-8P	1871355 / 1871328	09/30/2021	12
RE	MSA-03	141884	Spectrum Analyzer	Keysight Technologies Inc	E4448A	MY44020357	03/31/2022	12
RE	MURC-08	141959	Radio Communication Analyzer	Anritsu Corporation	MT8821C	6201547850	-	-

\*Hyphens for Last Calibration Date and Cal Int (month) are instruments that Calibration is not required (e.g. software), or instruments checked in advance before use.

The expiration date of the calibration is the end of the expired month.

As for some calibrations performed after the tested dates, those test equipment have been controlled by means of an unbroken chains of calibrations.

The expiration\*1) This test equipment was used for the tests before the expiration date of the calibration.

All equipment is calibrated with valid calibrations. Each measurement data is traceable to the national or international standards.

Test item: RE: Radiated Emission test