



TEST REPORT

Report Number : 13489136-E1V2

Applicant : PANASONIC CORPORATION OF NORTH AMERICA

Model : WW18A

FCC ID : ACJ9TGWW18C

Test Standard(s) : FCC PART 96.47

Date Of Issue:

May 28, 2021

Prepared by:

UL Verification Services Inc.

47173 Benicia Street

Fremont, CA 94538, U.S.A.

TEL: (510) 771-1000

FAX: (510) 661-0888



NVLAP LAB CODE 200065-0

Revision History

<u>Rev.</u>	<u>Issue Date</u>	<u>Revisions</u>	<u>Revised By</u>
V1	5/18/2021	Initial Issue	Dan Corona
V2	5/28/2021	Section 3: Updated Information of Test Sites	Dan Corona

TABLE OF CONTENTS

1. ATTESTATION OF TEST RESULTS	4
2. TEST METHODOLOGY	5
3. FACILITIES AND ACCREDITATION	5
4. DECISION RULES AND MEASUREMENT UNCERTAINTY	6
4.1. METROLOGICAL TRACEABILITY	6
4.2. DECISION RULES	6
4.3. MEASUREMENT UNCERTAINTY	6
4.4. CALIBRATION.....	6
4.5. MEASURING INSTRUMENT CALIBRATION	6
5. EQUIPMENT UNDER TEST	7
5.1. DESCRIPTION OF EUT.....	7
5.2. SOFTWARE AND FIRMWARE.....	7
5.3. DESCRIPTION OF TEST SETUP.....	7
6. TEST AND MEASUREMENT EQUIPMENT	9
7. END USER DEVICE ADDITIONAL REQUIREMENT	10
7.1. Test Requirement.....	10
8. TEST PROCEDURE AND EUT CONFIGURATION	10
8.1. End User Device Configuration 1	11
8.2. End User Device Configuration 2	13
9. SETUP PHOTOS	15

1. ATTESTATION OF TEST RESULTS

COMPANY NAME: PANASONIC CORPORATION OF NORTH AMERICA
EUT DESCRIPTION: Radio Module
MODEL: WW18A
SERIAL NUMBER: FM-201EDVT1V5
DATE TESTED: 4/24/2021

APPLICABLE STANDARDS	
STANDARD	TEST RESULTS
FCC PART 96.47	Complies

UL Verification Services Inc. tested the above equipment in accordance with the requirements set forth in the above standards. All indications of Pass/Fail in this report are opinions expressed by UL Verification Services Inc. based on interpretations and/or observations of test results. Measurement Uncertainties were not taken into account and are published for informational purposes only. The test results show that the equipment tested is capable of demonstrating compliance with the requirements as documented in this report.

Note: The results documented in this report apply only to the tested sample, under the conditions and modes of operation as described herein. This document may not be altered or revised in any way unless done so by UL Verification Services Inc. and all revisions are duly noted in the revisions section. Any alteration of this document not carried out by UL Verification Services Inc. will constitute fraud and shall nullify the document. This report must not be used by the client to claim product certification, approval, or endorsement by NVLAP, NIST, any agency of the Federal Government, or any agency of any government.

Approved & Released For
UL Verification Services Inc. By:

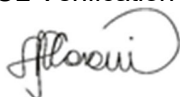

Dan Corona
Operations Leader
UL Verification Services Inc.

Prepared By:



Steven Tran
Project Lead
UL Verification Services Inc.

2. TEST METHODOLOGY

The tests documented in this report were performed in accordance with FCC Part 96.47, KDB 940660 D01 Part 96 CBRS v03 and WINNF-TS-0122-v1.0.2.

3. FACILITIES AND ACCREDITATION

UL Verification Services Inc. is accredited by NVLAP, Laboratory Code 200065-0, for all testing performed within the scope of this report. Testing was performed at the locations noted below.

	Address	ISED CABID	ISED Company Number	FCC Registration
<input type="checkbox"/>	Building 1: 47173 Benicia Street, Fremont, CA 94538	US0104	2324A	208313
<input checked="" type="checkbox"/>	Building 2: 47266 Benicia Street, Fremont, CA 94538	US0104	22541	208313
<input type="checkbox"/>	Building 4: 47658 Kato Rd, Fremont, CA 94538	US0104	2324B	208313

4. DECISION RULES AND MEASUREMENT UNCERTAINTY

4.1. METROLOGICAL TRACEABILITY

All test and measuring equipment utilized to perform the tests documented in this report are calibrated on a regular basis, with a maximum time between calibrations of one year or the manufacturers' recommendation, whichever is less, and where applicable is traceable to recognized national standards.

4.2. DECISION RULES

The Decision Rule is based on Simple Acceptance in accordance with ISO Guide 98-4:2012 Clause 8.2. (Measurement uncertainty is not taken into account when stating conformity with a specified requirement.)

4.3. MEASUREMENT UNCERTAINTY

Where relevant, the following measurement uncertainty levels have been estimated for tests performed on the apparatus:

PARAMETER	U _{LAB}
Worst Case Conducted Disturbance, 9KHz to 0.15 MHz	3.39 dB
Worst Case Conducted Disturbance, 0.15 to 30 MHz	3.07 dB
Worst Case Radiated Disturbance, 9KHz to 30 MHz	2.52 dB
Worst Case Radiated Disturbance, 30 to 1000 MHz	4.88 dB
Worst Case Radiated Disturbance, 1000 to 18000 MHz	4.24 dB
Worst Case Radiated Disturbance, 18000 to 26000 MHz	4.37 dB
Worst Case Radiated Disturbance, 26000 to 40000 MHz	5.17 dB

Uncertainty figures are valid to a confidence level of 95%.

4.4. CALIBRATION

4.5. MEASURING INSTRUMENT CALIBRATION

The measuring equipment utilized to perform the tests documented in this report has been calibrated in accordance with the manufacturer's recommendations, and is traceable to recognized national standards.

5. EQUIPMENT UNDER TEST

5.1. DESCRIPTION OF EUT

EUT is a radio module.

5.2. SOFTWARE AND FIRMWARE

The test utility software used during testing was WINNF-TS-0122 V1.0.2

5.3. DESCRIPTION OF TEST SETUP

SUPPORT EQUIPMENT

Support Equipment List				
Description	Manufacturer	Model	Serial Number	FCC ID
Router/AC/DC adapter	ASUS	AC1900	GCIAGO000300	MSQ-RTAC6Uv2
Laptop AC/DC adapter	Lenovo	4236B92	PBFBKHK	ODS-BRCM1046
Directional Coupler	Krytar	152613	T1537	NA

I/O CABLES

I/O Cable List						
Cable No	Port	# of identical ports	Connector Type	Cable Type	Cable Length (m)	Remarks
1	AC	1	AC	Un-Shielded	1	N/A
3	RJ45	3	Ethernet	Un-Shielded	1	N/A
2	RF Port	2	SMA	Shielded	0.5	N/A

TEST SETUP

The standalone EUT connected to a certified CBSD and Spectrum Analyzer via air and an RF cable respectively.

SETUP DIAGRAM OF TEST SYSTEM

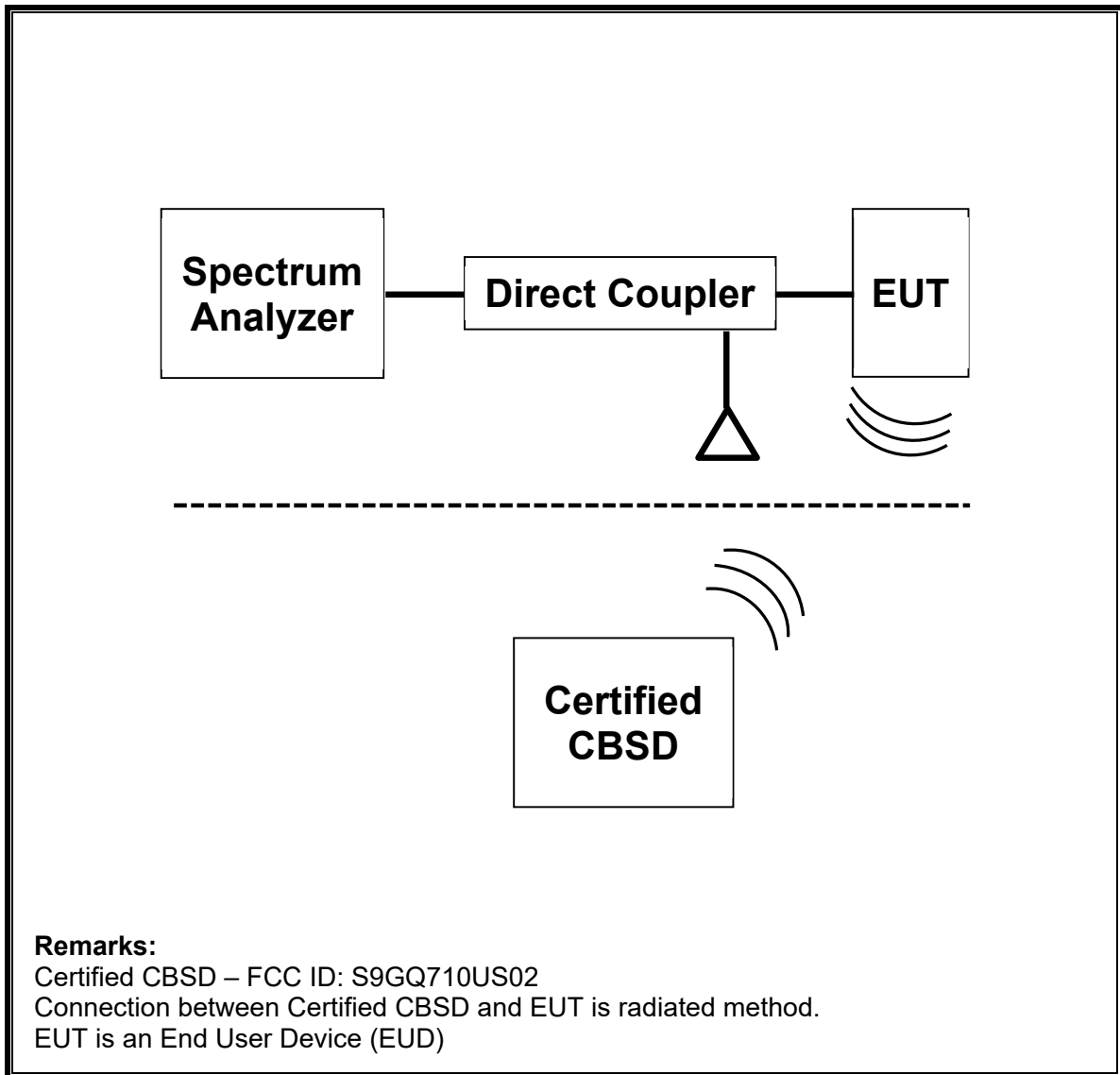

6. TEST AND MEASUREMENT EQUIPMENT

The following test and measurement equipment was utilized for the tests documented in this report:

Test Equipment List				
Description	Manufacturer	Model	ID Num	Cal Due
Spectrum Analyzer, PXA, 3Hz to 44GHz	Agilent (Keysight) Technologies	N9030A	T113	03/08/2022

Test Software			
Description	Manufacturer	Model	Version Number
Laptop (Local SAS – WINNForum Test Harness)	Lenovo	PBFBKHK	2.0

7. END USER DEVICE ADDITIONAL REQUIREMENT

7.1. Test Requirement

FCC Part 96.47

- (a) End User Devices may operate only if they can positively receive and decode an authorization signal transmitted by a CBSD, including the frequencies and power limits for their operation.
- (1) An End User Device must discontinue operations, change frequencies, or change its operational power level within 10 seconds of receiving instructions from its associated CBSD.

8. TEST PROCEDURE AND EUT CONFIGURATION

KDB 940660 D01 Part 96 CBRS v03, WINNF-TS-0122 V1.0.2

Additional requirements are required to End-User Device LTE Band 48 device base on CBSD protocol. During the test, the EUT and its companion certified CBSD (FCC ID: S9GQ710US02) device communicate with each other via air.

Configuration	Frequency (MHz)	Power (dBm/MHz)	Bandwidth (MHz)
1	3615 - 3635	13	20
2	3660 - 3670	8	10

Configuration 1

- a) Setup WINNF.PT.C.HBT.1 with 3615MHz-3635MHz and power level 13 dBm/MHz
- b) Enable AP service from Ruckus Cloud Management
- c) Check EUT Transmitter Frequency and power
- d) Disable AP service from Ruckus Cloud management and check EUT stop transmission within 10s.

Configuration 2

- a) Setup WINNF.PT.C.HBT.1 with 3660MHz-3670MHz and power level 8 dBm/MHz
- b) Enable AP service from Ruckus Cloud Management
- c) Check EUT Transmitter Frequency and power
- d) Disable AP service from Ruckus Cloud Management and check EUT stop transmission within 10s.

TEST RESULTS

8.1. End User Device Configuration 1 (3615MHz - 3635MHz; MaxEIRP: 13 dBm/MHz)

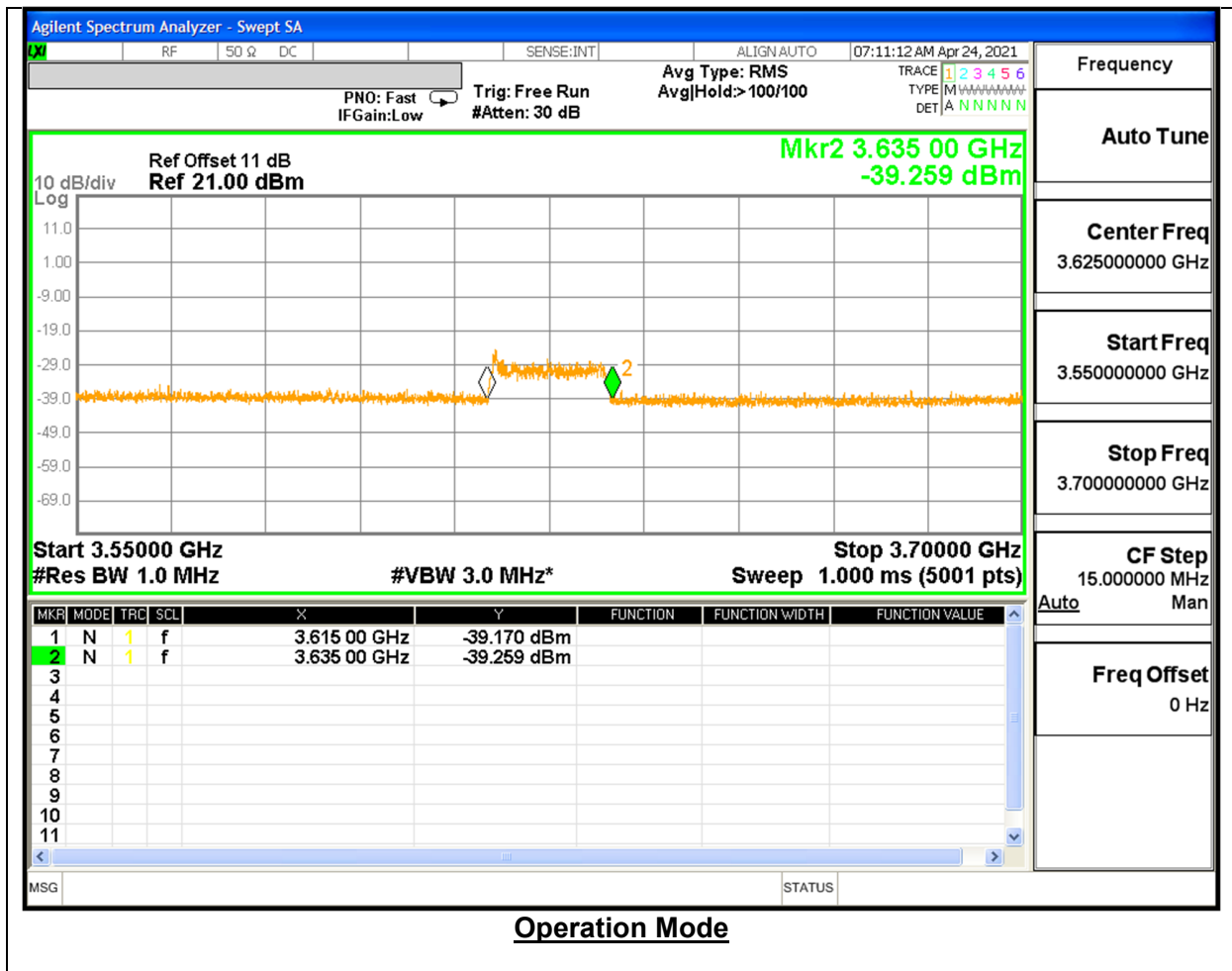

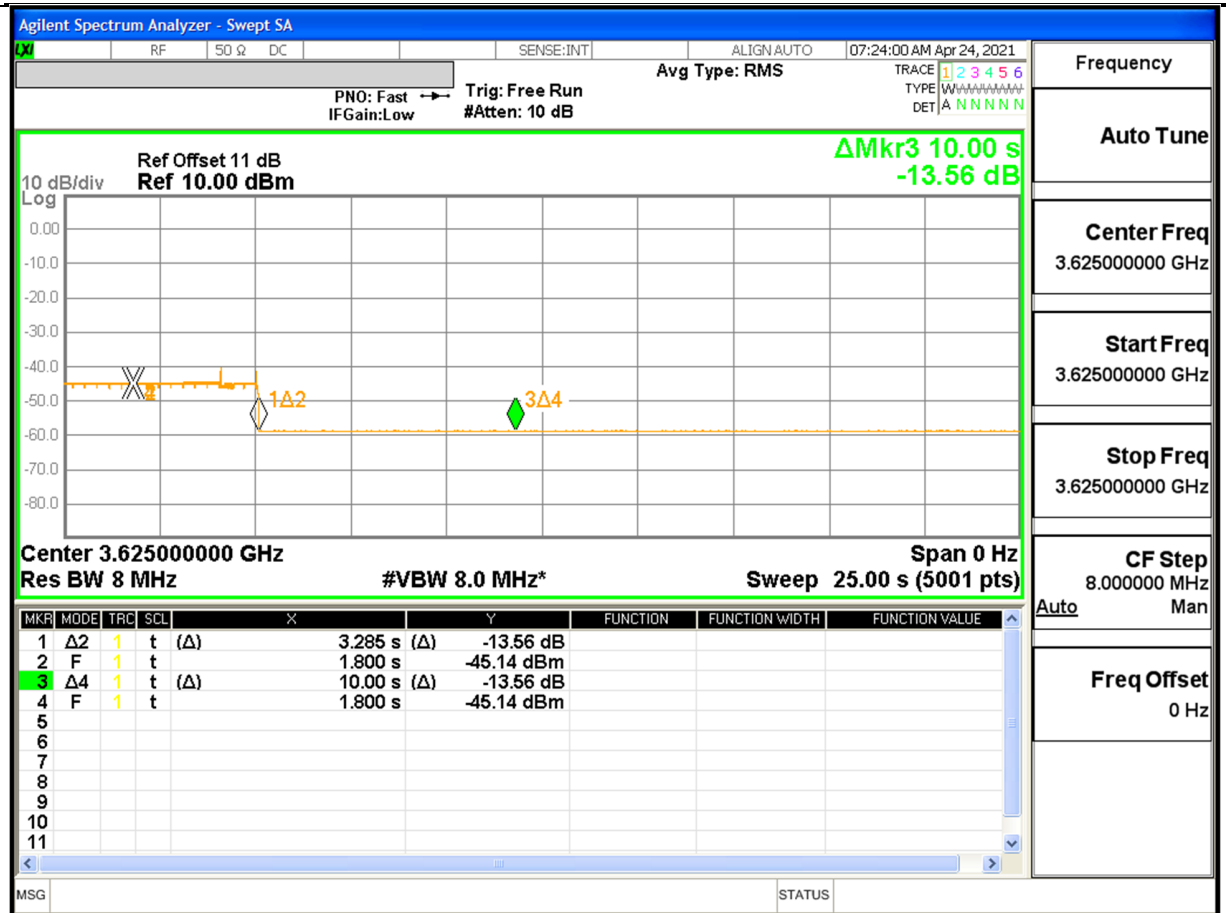

Stop Operation Within 10 second Mode

NOTE:

Marker 1: Authorized CBSD sends a signal to stop LTE transmission.
 Marker 2: Time elapsed since signal to stop LTE transmission. EUD has stopped transmission.
 Marker 3-4 Delta: 10 seconds has elapsed since CBSD has sent a signal to stop LTE transmission to EUT.

8.2. End User Device Configuration 2 (3660MHz - 3670MHz; MaxEIRP: 8 dBm/MHz)

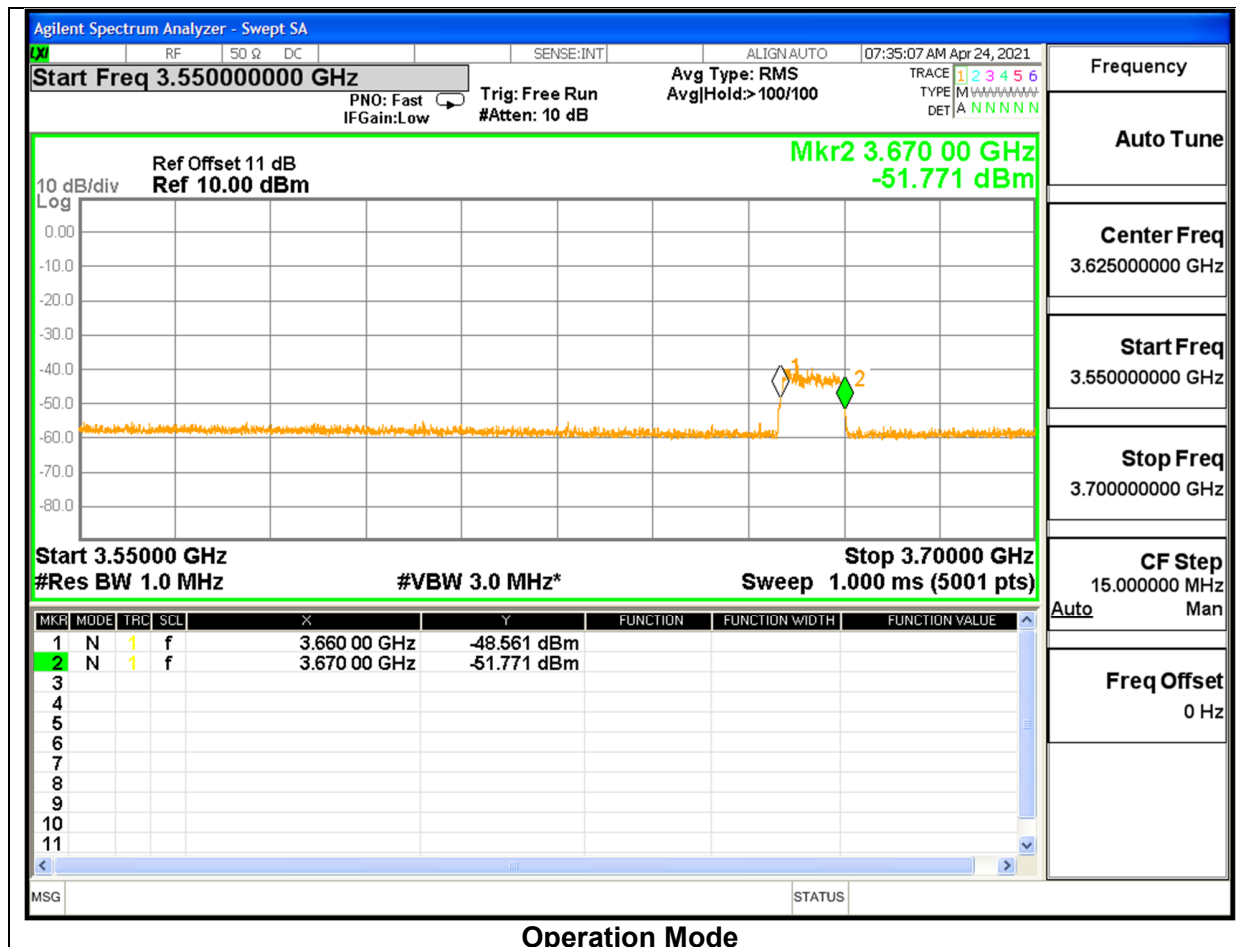



Stop Operation Within 10 second Mode

NOTE:

- Marker 1: Authorized CBSD sends a signal to stop LTE transmission.
- Marker 2: Time elapsed since signal to stop LTE transmission. EUD has stopped transmission.
- Marker 3-4 Delta: 10 seconds has elapsed since CBSD has sent a signal to stop LTE transmission to EUT.