



# RADIO TEST REPORT

Test Report No. : 11500829H-C-R1

**Applicant** : Panasonic Corporation of North America  
**Type of Equipment** : Common Trigger Box  
**Model No.** : WV-TW37003  
**FCC ID** : ACJ9TAWV-TW37003  
**Test regulation** : FCC Part 15 Subpart E: 2016  
**Test Result** : Complied

1. This test report shall not be reproduced in full or partial, without the written approval of UL Japan, Inc.
2. The results in this report apply only to the sample tested.
3. This sample tested is in compliance with the above regulation.
4. The test results in this report are traceable to the national or international standards.
5. This test report must not be used by the customer to claim product certification, approval, or endorsement by NVLAP, NIST, or any agency of the Federal Government.
6. This test report covers Radio technical requirements. It does not cover administrative issues such as Manual or non-Radio test related Requirements. (if applicable)
7. This report is a revised version of 11500829H-C. 11500829H-C is replaced with this report.

**Date of test:** December 15 to 22, 2016

**Representative test engineer:**

  
Tomoki Matsui  
Engineer  
Consumer Technology Division

**Approved by:**

  
Tsubasa Takayama  
Engineer  
Consumer Technology Division



NVLAP LAB CODE: 200572-0

This laboratory is accredited by the NVLAP LAB CODE 200572-0, U.S.A. The tests reported herein have been performed in accordance with its terms of accreditation.  
\*As for the range of Accreditation in NVLAP, you may refer to the WEB address,  
[http://japan.ul.com/resources/emc\\_accredited/](http://japan.ul.com/resources/emc_accredited/)

**UL Japan, Inc.**

**Ise EMC Lab.**

4383-326 Asama-cho, Ise-shi, Mie-ken 516-0021 JAPAN

Telephone : +81 596 24 8999

Facsimile : +81 596 24 8124

13-EM-F0429



<b>CONTENTS</b>	<b>PAGE</b>
<b>SECTION 1: Customer information.....</b>	<b>4</b>
<b>SECTION 2: Equipment under test (E.U.T.).....</b>	<b>4</b>
<b>SECTION 3: Test specification, procedures &amp; results.....</b>	<b>6</b>
<b>SECTION 4: Operation of E.U.T. during testing.....</b>	<b>9</b>
<b>SECTION 5: Radiated Spurious Emission and Band Edge Compliance .....</b>	<b>12</b>
<b>SECTION 6: Antenna Terminal Conducted Tests.....</b>	<b>14</b>
<b>APPENDIX 1: Test data .....</b>	<b>15</b>
99 % Occupied Bandwidth.....	15
6 dB Bandwidth .....	19
Maximum Conducted Output Power .....	23
Average Output Power .....	30
Maximum Power Spectral Density .....	36
Radiated Spurious Emission .....	42
Conducted Spurious Emission .....	59
<b>APPENDIX 2: Test instruments .....</b>	<b>60</b>
<b>APPENDIX 3: Photographs of test setup .....</b>	<b>62</b>
Radiated Spurious Emission .....	62
Worst Case Position .....	63

## **SECTION 1: Customer information**

### **Applicant**

Company Name : Panasonic Corporation of North America  
Address : Two Riverfront Plaza, Newark, NJ 07102-5490  
Telephone Number : +1-201-348-7724  
Facsimile Number : +1-201-392-4564  
Contact Person : Vir Angelo Lontoc

### **Manufacturer**

Company Name : Panasonic System Networks Co., Ltd.  
Address : 4-1-62, Minoshima, Hakata-ku, Fukuoka 812-8531, Japan  
Telephone Number : +81-50-3380-1993  
Facsimile Number : +81-50-3380-2002  
Contact Person : Yukio Kaneko

#### **\*Remarks:**

Panasonic Corporation of North America designates Panasonic System Networks Co., Ltd. as manufacturer of the product (Common Trigger Box).

## **SECTION 2: Equipment under test (E.U.T.)**

### **2.1 Identification of E.U.T.**

Type of Equipment : Common Trigger Box  
Model No. : WV-TW37003  
Serial No. : Refer to Section 4, Clause 4.2  
Rating : DC 12 V, DC 24 V  
Receipt Date of Sample : December 10, 2016  
Country of Mass-production : Japan  
Condition of EUT : Engineering prototype  
(Not for Sale: This sample is equivalent to mass-produced items.)  
Modification of EUT : No Modification by the test lab

---

**UL Japan, Inc.**

**Ise EMC Lab.**

4383-326 Asama-cho, Ise-shi, Mie-ken 516-0021 JAPAN

Telephone : +81 596 24 8999

Facsimile : +81 596 24 8124

## 2.2 Product Description

Model: WV-TW37003 (referred to as the EUT in this report) is a Common Trigger Box.

### Radio Specification

Radio Type : Transceiver  
Power Supply (inner) : DC 4.0 V (POWER), DC 1.8 V (IO)  
Clock frequency (crystal) : 37.4 MHz

	IEEE802.11b	IEEE802.11g/n (20 M band)	IEEE802.11a/n/ac (20 M band)	IEEE802.11n/ac (40 M band)	IEEE802.11ac (80 M band)
Frequency of operation	2412 MHz to 2462 MHz	2412 MHz to 2462 MHz	5745 MHz to 5825 MHz *1)	5755 MHz *1) 5795 MHz *1)	5775 MHz *1)
Type of modulation	DSSS (CCK, DQPSK, DBPSK)	OFDM-CCK (64QAM, 16QAM, QPSK, BPSK)	OFDM (64QAM, 16QAM, QPSK, BPSK, 256QAM(IEEE802.11ac only))		
Channel spacing	5MHz		20MHz	40MHz	80MHz
Antenna type	Patterned dipole antenna				
Antenna Connector type	RP-SMA Jack (Female)				
Antenna Gain	-0.8 dBi (2.4 GHz Band), -8.1 dBi (5 GHz Band) *including cable loss				

	Bluetooth Ver.4.1 with EDR function / Bluetooth Low Energy
Frequency of operation	2402 MHz - 2480 MHz
Type of modulation	BT: FHSS (GFSK, $\pi/4$ -DQPSK, 8-DPSK) LE: GFSK
Channel spacing	BT: 1 MHz LE: 2 MHz
Antenna type	Patterned dipole antenna
Antenna Connector type	RP-SMA Jack (Female)
Antenna Gain	-0.8 dBi *including cable loss

\*1) This test report applies to WLAN (5 GHz band).

\*Wireless LAN and Bluetooth do not transmit simultaneously.

## **SECTION 3: Test specification, procedures & results**

### **3.1 Test Specification**

Test Specification : FCC Part 15 Subpart E  
FCC Part 15 final revised on November 14, 2016 and effective December 14, 2016

Title : FCC 47CFR Part15 Radio Frequency Device Subpart E  
Unlicensed National Information Infrastructure Devices  
Section 15.407 General technical requirements

### **3.2 Procedures and results**

Item	Test Procedure	Specification	Worst margin	Results	Remarks
Conducted Emission	FCC: ANSI C63.10-2013	FCC: 15.407 (b) (6) / 15.207	-	N/A *1)	-
	IC: RSS-Gen 8.8	IC: RSS-Gen 8.8			
26 dB Emission Bandwidth	FCC: KDB Publication Number 789033	FCC: 15.407 (a) (1) (2) (3)	See data	N/A	Conducted
	IC: -	IC: -			
Maximum Conducted Output Power	FCC: KDB Publication Number 789033	FCC: 15.407 (a) (1) (2) (3)		Complied	Conducted
	IC: -	IC: RSS-247 6.2.1 (1) 6.2.2 (1) 6.2.3 (1) 6.2.4 (1)			
Maximum Power Spectral Density	FCC: KDB Publication Number 789033	FCC : 15.407 (a) (1) (2) (3)		Complied	Conducted
	IC: -	IC: RSS-247 6.2.1 (1) 6.2.2 (1) 6.2.3 (1) 6.2.4 (1)			
Spurious Emission Restricted Band Edge	FCC: ANSI C63.10-2013 KDB Publication Number 789033	FCC: 15.407 (b), 15.205 and 15.209	2.0 dB 1150.000 MHz, Horizontal, AV	Complied	Conducted (< 30 MHz) / Radiated (> 30 MHz) *2)
	IC: -	IC: RSS-247 6.2.1 (2) 6.2.2 (2) 6.2.3 (2) 6.2.4 (2)			
6 dB Emission Bandwidth	FCC: ANSI C63.10-2013	FCC: 15.407 (e)	See data	Complied	Conducted
	IC: -	IC: RSS-247 6.2.4 (1)			

Note: UL Japan, Inc.'s EMI Work Procedures No. 13-EM-W0420 and 13-EM-W0422.

\*1) The test is not applicable since the EUT is not the device that is designed to be connected to the public utility (AC) power line.

\*2) Radiated test was selected over 30 MHz based on section FCC 15.407 (b) and KDB 789033 D02 G.3.b).

\* In case any questions arise about test procedure, ANSI C63.10: 2013 is also referred.

#### **FCC Part 15.31 (e)**

The EUT provides stable voltage (DC 4.0 V, DC 1.8 V) constantly to the wireless transmitter regardless of input voltage. The test was performed with DC 12.0 V by using DC power supply.

That does not affect the test result, therefore the EUT complies with the requirement.

#### **FCC Part 15.203 Antenna requirement**

The EUT has a unique coupling/antenna connector (RP-SMA Jack). Therefore the equipment complies with the requirement of 15.203.

**UL Japan, Inc.**

**Ise EMC Lab.**

4383-326 Asama-cho, Ise-shi, Mie-ken 516-0021 JAPAN

Telephone : +81 596 24 8999

Facsimile : +81 596 24 8124

### 3.3 Addition to standard

Item	Test Procedure	Specification	Worst margin	Results	Remarks
99 % Occupied Band Width	RSS-Gen 6.6	IC: -	N/A	N/A	Conducted

Other than above, no addition, exclusion nor deviation has been made from the standard.

### 3.4 Uncertainty

#### EMI

The following uncertainties have been calculated to provide a confidence level of 95 % using a coverage factor  $k=2$ .  
Ise EMC Lab.

Antenna terminal test Uncertainty (+/-)							
Power meter		Conducted emission and Power density			Conducted emission		Channel power
Below 1 GHz	Above 1 GHz	Below 1 GHz	1 GHz - 3 GHz	3 GHz - 18 GHz	18 GHz - 26.5 GHz	26.5 GHz - 40 GHz	
0.9 dB	1.0 dB	1.4 dB	1.5 dB	2.8 dB	2.8 dB	2.9 dB	

Test distance	Radiated emission (+/-) 9 kHz - 30 MHz
3m	3.8 dB
10m	3.7 dB

Polarity	Radiated emission (Below 1GHz)			
	(3 m*) (+/-)		(10 m*) (+/-)	
	30 - 200 MHz	200 - 1000MHz	30 - 200 MHz	200 - 1000MHz
Horizontal	5.0 dB	5.3 dB	5.0 dB	5.0 dB
Vertical	4.7 dB	5.9 dB	5.0 dB	5.1 dB

Radiated emission (Above 1GHz)				
(3 m*) (+/-)		(1 m*) (+/-)		(10 m*) (+/-)
1 - 6GHz	6 - 18GHz	10 - 26.5 GHz	26.5 - 40GHz	1 - 18 GHz
5.2 dB	5.4 dB	5.5 dB	5.5 dB	5.4 dB

\*Measurement distance

#### Radiated emission test

The data listed in this report meets the limits unless the uncertainty is taken into consideration.

### 3.5 Test Location

UL Japan, Inc. Ise EMC Lab. \*NVLAP Lab. code: 200572-0  
4383-326 Asama-cho, Ise-shi, Mie-ken 516-0021 JAPAN  
Telephone: +81 596 24 8999, Facsimile: +81 596 24 8124

Test site	IC Registration Number	Width x Depth x Height (m)	Size of reference ground plane (m) / horizontal conducting plane	Other rooms	Maximum measurement distance
No.1 semi-anechoic chamber	2973C-1	19.2 x 11.2 x 7.7	7.0 x 6.0	No.1 Power source room	10 m
No.2 semi-anechoic chamber	2973C-2	7.5 x 5.8 x 5.2	4.0 x 4.0	-	3 m
No.3 semi-anechoic chamber	2973C-3	12.0 x 8.5 x 5.9	6.8 x 5.75	No.3 Preparation room	3 m
No.3 shielded room	-	4.0 x 6.0 x 2.7	N/A	-	-
No.4 semi-anechoic chamber	2973C-4	12.0 x 8.5 x 5.9	6.8 x 5.75	No.4 Preparation room	3 m
No.4 shielded room	-	4.0 x 6.0 x 2.7	N/A	-	-
No.5 semi-anechoic chamber	-	6.0 x 6.0 x 3.9	6.0 x 6.0	-	-
No.6 shielded room	-	4.0 x 4.5 x 2.7	4.0 x 4.5	-	-
No.6 measurement room	-	4.75 x 5.4 x 3.0	4.75 x 4.15	-	-
No.7 shielded room	-	4.7 x 7.5 x 2.7	4.7 x 7.5	-	-
No.8 measurement room	-	3.1 x 5.0 x 2.7	N/A	-	-
No.9 measurement room	-	8.8 x 4.6 x 2.8	2.4 x 2.4	-	-
No.11 measurement room	-	6.2 x 4.7 x 3.0	4.8 x 4.6	-	-

\* Size of vertical conducting plane (for Conducted Emission test) : 2.0 x 2.0 m for No.1, No.2, No.3, and No.4 semi-anechoic chambers and No.3 and No.4 shielded rooms.

### 3.6 Test data, Test instruments, and Test set up

Refer to APPENDIX.

**UL Japan, Inc.**

**Ise EMC Lab.**

4383-326 Asama-cho, Ise-shi, Mie-ken 516-0021 JAPAN

Telephone : +81 596 24 8999

Facsimile : +81 596 24 8124

## **SECTION 4: Operation of E.U.T. during testing**

### **4.1 Operating Mode(s)**

Test operating mode was determined as follows according to “Section 1 of 6 802.11 a/b/g/n testing - Managing Complex Regulatory Approvals -” of TCB Council Workshop October 2009 and also was judged the necessity of 802.11ac mode by the pre-test.

<b>Mode</b>	<b>Remarks*</b>
IEEE 802.11a (11a)	6 Mbps, PN9
IEEE 802.11n 20 MHz BW (11n-20)	MCS 7 (Long GI), PN9
IEEE 802.11ac 20 MHz BW (11ac-20)	MCS 8 (Long GI), PN9
IEEE 802.11n 40 MHz BW (11n-40)	MCS 5 (Short GI), PN9
IEEE 802.11ac 40 MHz BW (11ac-40)	MCS 1 (Short GI), PN9
IEEE 802.11ac 80 MHz BW (11ac-80)	MCS 9 (Long GI), PN9
*The worst condition was determined based on the test result of Maximum Conducted Output Power.	
*The power value of the EUT was set for testing as follows (setting value might be different from product specification value); Power settings: Same as production model Software: bcm43455c0 *This setting of software is the worst case. Any conditions under the normal use do not exceed the condition of setting. In addition, end users cannot change the settings of the output power of the product.	

\*The details of Operation mode(s)

<b>Test Item</b>	<b>Operating Mode</b>	<b>Tested Frequency</b>			
		<b>Lower Band</b>	<b>Middle Band</b>	<b>Additional Band</b>	<b>Upper Band</b>
99 % Occupied Bandwidth, Maximum Conducted Output Power, Maximum Power Spectral Density	11a Tx	-	-	-	5745 MHz
	11n-20 Tx	-	-	-	5785 MHz
	11ac-20 Tx	-	-	-	5825 MHz
	11n-40 Tx	-	-	-	5755 MHz
	11ac-40 Tx	-	-	-	5795 MHz
6 dB Bandwidth	11a Tx	-	-	-	5745 MHz
	11n-20 Tx	-	-	-	5785 MHz
	11ac-20 Tx	-	-	-	5825 MHz
	11n-40 Tx	-	-	-	5755 MHz
	11ac-40 Tx	-	-	-	5795 MHz
Radiated Spurious Emission (Below 1 GHz)	11a Tx *1)	-	-	-	5825 MHz
	11ac-80 Tx	-	-	-	5775 MHz
Radiated Spurious Emission (Above 1 GHz)	11a Tx	-	-	-	5745 MHz
	11ac-20 Tx *2)	-	-	-	5785 MHz
	11ac-40 Tx *2)	-	-	-	5825 MHz
	11n-40 Tx	-	-	-	5755 MHz
	11ac-40 Tx	-	-	-	5795 MHz
Conducted Spurious Emission	11a Tx *1)	-	-	-	5825 MHz

\*1) The mode was tested as a representative, because it had the highest power at antenna terminal test.  
\*2) Since 11n-20 and 11ac-20 / 11n-40 and 11ac-40 have the same modulation method and no differences in transmitting specification, test was performed on the representative mode that had the highest output power.

**UL Japan, Inc.**

**Ise EMC Lab.**

4383-326 Asama-cho, Ise-shi, Mie-ken 516-0021 JAPAN

Telephone : +81 596 24 8999

Facsimile : +81 596 24 8124

## 4.2 Configuration and peripherals

### For Radiated Spurious Emission test

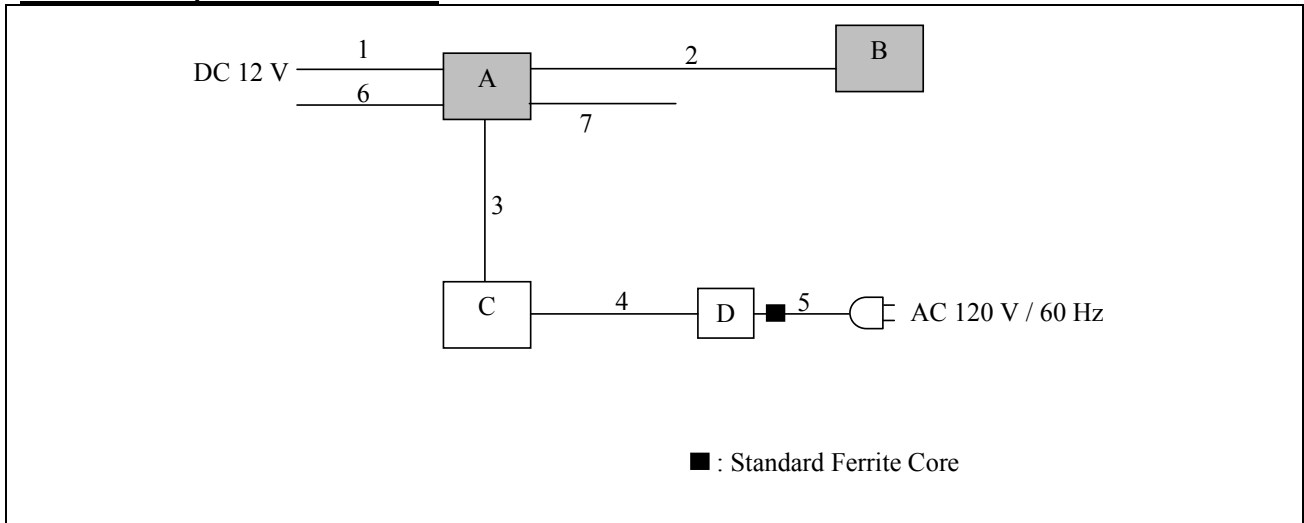

\* Cabling and setup(s) were taken into consideration and test data was taken under worse case conditions.

### Description of EUT and Support equipment

No.	Item	Model number	Serial number	Manufacturer	Remarks
A	Common Trigger Box	WV-TW37003	001	Panasonic System Networks Co., Ltd.	EUT
B	Antenna	AP-W-M-S2-R P-WH	001	ANTENNA PLUS	EUT
C	Laptop PC	T60	L3-DM302	IBM	-
D	AC Adapter	92P1160	11S92P1160Z1ZBGH6B6DKV	IBM	-

### List of cables used

No.	Name	Length (m)	Shield		Remarks
			Cable	Connector	
1	DC Cable	2.0	Unshielded	Unshielded	-
2	Antenna Cable	3.0	Shielded	Shielded	-
3	LAN Cable	3.0	Unshielded	Unshielded	-
4	DC Cable	1.8	Unshielded	Unshielded	-
5	AC Cable	0.9	Unshielded	Unshielded	-
6	Signal Cable	1.0	Unshielded	Unshielded	-
7	Flat Cable	0.12	Unshielded	Unshielded	-

**UL Japan, Inc.**

**Ise EMC Lab.**

4383-326 Asama-cho, Ise-shi, Mie-ken 516-0021 JAPAN

Telephone : +81 596 24 8999

Facsimile : +81 596 24 8124

**For Antenna Terminal Conducted Tests**

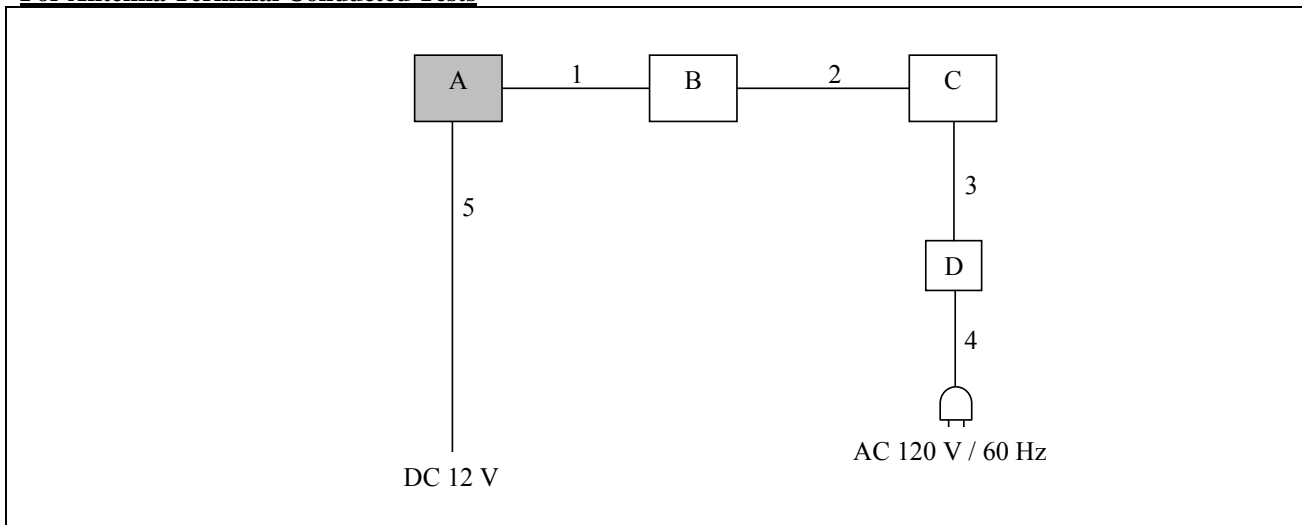

\* Cabling and setup(s) were taken into consideration and test data was taken under worse case conditions.

**Description of EUT and Support equipment**

No.	Item	Model number	Serial number	Manufacturer	Remarks
A	Common Trigger Box	WV-TW37003	002	Panasonic System Networks Co., Ltd.	EUT
B	Jig	-	-	-	-
C	Laptop PC	T450	0715PC06BG66	Lenovo	-
D	AC Adapter	ADLX65NCC2A	11S45N0263Z1ZS995578FZ	Lenovo	-

**List of cables used**

No.	Name	Length (m)	Shield		Remarks
			Cable	Connector	
1	Flat Cable	0.12	Unshielded	Unshielded	-
2	USB Cable	0.7	Unshielded	Unshielded	-
3	DC Cable	1.6	Unshielded	Unshielded	-
4	AC Cable	0.8	Unshielded	Unshielded	-
5	DC Cable	0.6	Unshielded	Unshielded	-

## **SECTION 5: Radiated Spurious Emission and Band Edge Compliance**

### **Test Procedure**

< Below 1GHz >

EUT was placed on a urethane platform of nominal size, 0.5 m by 1.0 m, raised 0.8 m above the conducting ground plane. The Radiated Electric Field Strength has been measured in a Semi Anechoic Chamber with a ground plane.

< Above 1GHz >

EUT was placed on a urethane platform of nominal size, 0.5 m by 0.5 m, raised 1.5 m above the conducting ground plane.

The Radiated Electric Field Strength has been measured in a Semi Anechoic Chamber with absorbent materials lined on a ground plane.

The height of the measuring antenna varied between 1 and 4 m and EUT was rotated a full revolution in order to obtain the maximum value of the electric field strength.

The measurements were performed for both vertical and horizontal antenna polarization with the Test Receiver, or the Spectrum Analyzer.

The measurements were made with the following detector function of the test receiver and the Spectrum analyzer (in linear mode).

The test was made with the detector (RBW/VBW) in the following table.

When using Spectrum analyzer, the test was made with adjusting span to zero by using peak hold.

< Below 1GHz >

The result also satisfied with the general limits specified in section 15.209 (a).

< Above 1GHz >

Inside of restricted bands (Section 15.205):

Apply to limit in the Section 15.209 (a).

Outside of the restricted bands:

Apply to limit in the Section 15.407 (b) (4).

Restricted band edge:

Apply to limit in the Section 15.209 (a).

Since this limit is severer than the limit of the inside of restricted bands.

\*Electric field strength to e.i.r.p. conversion:

$$E = \frac{1000000\sqrt{30P}}{3} \text{ (uV/m)} \quad :P \text{ is the e.i.r.p. (Watts)}$$

**Test Antennas are used as below;**

Frequency	30 MHz to 200 MHz	200 MHz to 1 GHz	Above 1 GHz
Antenna Type	Biconical	Logperiodic	Horn

Frequency	Below 1 GHz	Above 1 GHz	
Instrument used	Test Receiver	Spectrum Analyzer	
Detector	QP	Peak	Average
IF Bandwidth	BW: 120 kHz	RBW: 1 MHz VBW: 3 MHz	Method AD *1) RBW: 1 MHz VBW: 3 MHz Detector: Power Averaging (RMS) Trace: ≥ 100 traces If duty cycle was less than 98%, a duty factor was added to the results.
Test Distance	3 m	3 m*2) (1 GHz – 10GHz), 1 m*3) (10 GHz – 40 GHz)	

\*1) The test method was also referred to KDB 789033 D02 General UNII Test Procedures New Rules v01r03 "Guidelines for Compliance Testing of Unlicensed National Information Infrastructure (U-NII) Devices Part 15, Subpart E".

\*2) Distance Factor:  $20 \times \log(4.45 \text{ m}/3.0 \text{ m}) = 3.43 \text{ dB}$

\*3) Distance Factor:  $20 \times \log(1.0 \text{ m}/3.0 \text{ m}) = -9.5 \text{ dB}$

- The carrier level and noise levels were confirmed at each position of X, Y and Z axes of EUT (Common Trigger Box and antenna) to see the position of maximum noise, and the test was made at the position that has the maximum noise.

The test results and limit are rounded off to one decimal place, so some differences might be observed.

**Measurement range** : 30 MHz-40 GHz  
**Test data** : APPENDIX  
**Test result** : Pass

## **SECTION 6: Antenna Terminal Conducted Tests**

### **Test Procedure**

The tests were made with below setting connected to the antenna port.

<b>Test</b>	<b>Span</b>	<b>RBW</b>	<b>VBW</b>	<b>Sweep time</b>	<b>Detector</b>	<b>Trace</b>	<b>Instrument used and Test method</b>
99 % Occupied Bandwidth *1)	Enough width to display emission skirts	1 % to 5 % of OBW	≥ 3 RBW	Auto	Peak	Max Hold	Spectrum Analyzer
6 dB Bandwidth	Enough to capture the emission	100 kHz	300 kHz	Auto	Peak	Max Hold	Spectrum Analyzer
Maximum Conducted Output Power	-	-	-	Auto	Average	-	Power Meter (Sensor: 80 MHz BW) (Method PM)
Maximum Power Spectral Density	Encompass the entire EBW	470 kHz *2)	≥ 3 RBW	Auto	RMS Power Averaging	Clear Write	Spectrum Analyzer
Conducted Spurious Emission	9 kHz – 150 kHz	200 Hz	620 Hz	Auto	Peak	Max Hold	Spectrum Analyzer
	150 kHz – 30 MHz	9.1 kHz	27 kHz				

\* The test method was also referred to KDB 789033 D02 General UNII Test Procedures New Rules v01r03 "Guidelines for Compliance Testing of Unlicensed National Information Infrastructure (U-NII) Devices Part 15, Subpart E".

\*1) Peak hold was applied as Worst-case measurement.

\*2) KDB 789033 D02 says that RBW is set to be 500 kHz for 5.725 GHz-5.850 GHz, but it is not possible with spectrum analyzer, so RBW Correction Factor ( $10 \log(500 \text{ kHz} / 470 \text{ kHz})$ ) was added to the test result.

\*3) In the frequency range below 30 MHz, RBW was narrowed to separate the noise contents.

Then, wide-band noise near the limit was checked separately, however the noise was not detected as shown in the chart. (9 kHz-150 kHz: RBW = 200 Hz, 150 kHz-30 MHz: RBW = 9.1 kHz)

The test results and limit are rounded off to two decimals place, so some differences might be observed.

**Test data** : APPENDIX  
**Test result** : Pass

## APPENDIX 1: Test data

### 99 % Occupied Bandwidth

Test place Ise EMC Lab. No.6 Measurement Room  
Report No. 11500829H  
Date December 15, 2016  
Temperature / Humidity 23deg. C / 31 % RH  
Engineer Yutaka Yoshida  
Mode Tx

#### 11a, 6Mbps

Tested Frequency [MHz]	99 % Occupied Bandwidth [MHz]	Limit [MHz]
5745	17.274	-
5785	17.258	-
5825	17.247	-

#### 11n-20, MCS7, Long GI

Tested Frequency [MHz]	99 % Occupied Bandwidth [MHz]	Limit [MHz]
5745	18.058	-
5785	17.965	-
5825	18.008	-

#### 11n-40, MCS5, Short GI

Tested Frequency [MHz]	99 % Occupied Bandwidth [MHz]	Limit [MHz]
5755	36.271	-
5795	36.245	-

#### 11ac-20, MCS8, Long GI

Tested Frequency [MHz]	99 % Occupied Bandwidth [MHz]	Limit [MHz]
5745	17.996	-
5785	18.005	-
5825	17.981	-

#### 11ac-40, MCS1, Short GI

Tested Frequency [MHz]	99 % Occupied Bandwidth [MHz]	Limit [MHz]
5755	36.462	-
5795	36.355	-

#### 11ac-80, MCS9, Long GI

Tested Frequency [MHz]	99 % Occupied Bandwidth [MHz]	Limit [MHz]
5775	75.635	-

## 99 % Occupied Bandwidth

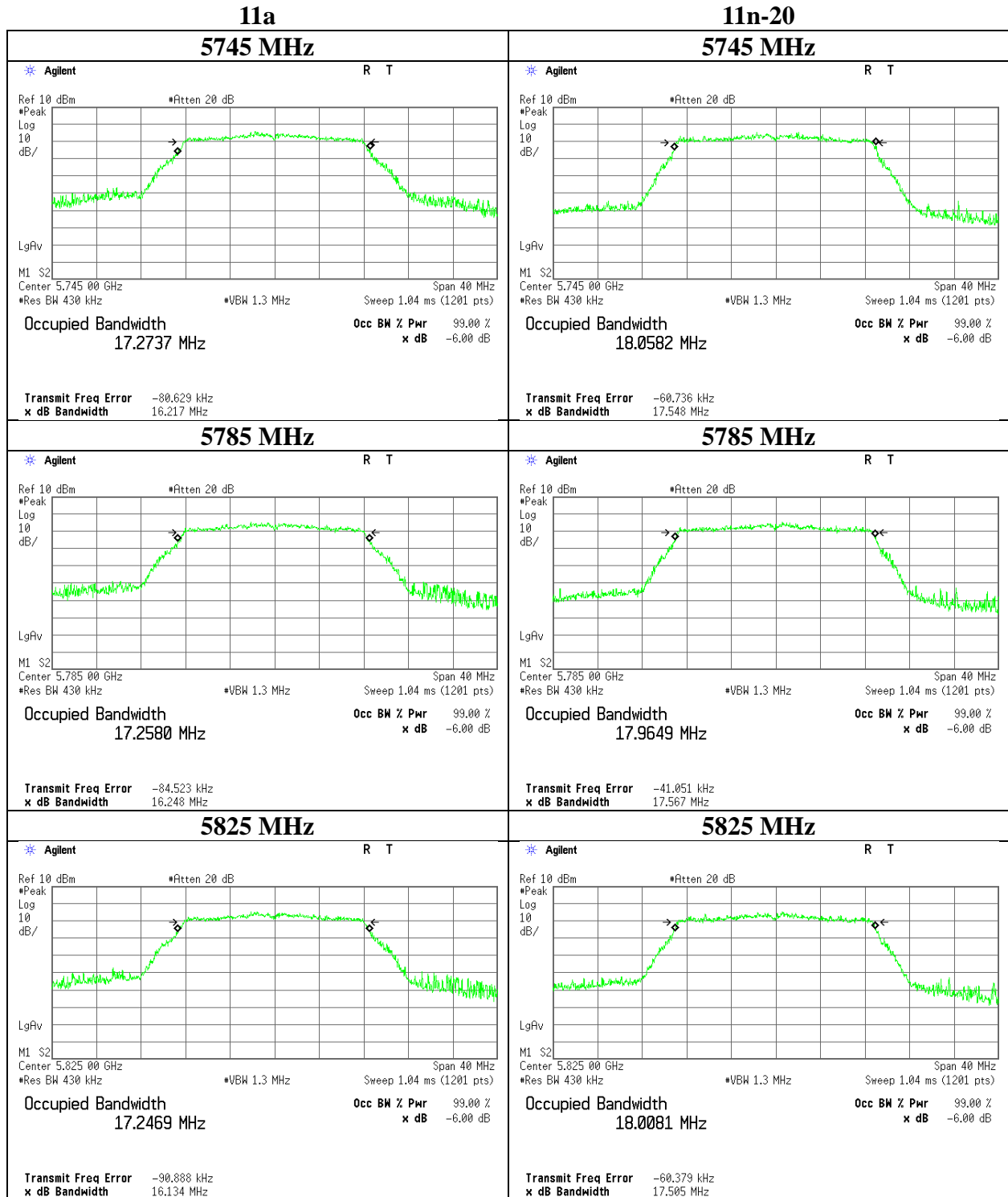

**UL Japan, Inc.**

**Ise EMC Lab.**

4383-326 Asama-cho, Ise-shi, Mie-ken 516-0021 JAPAN

Telephone : +81 596 24 8999

Facsimile : +81 596 24 8124

**99 % Occupied Bandwidth**

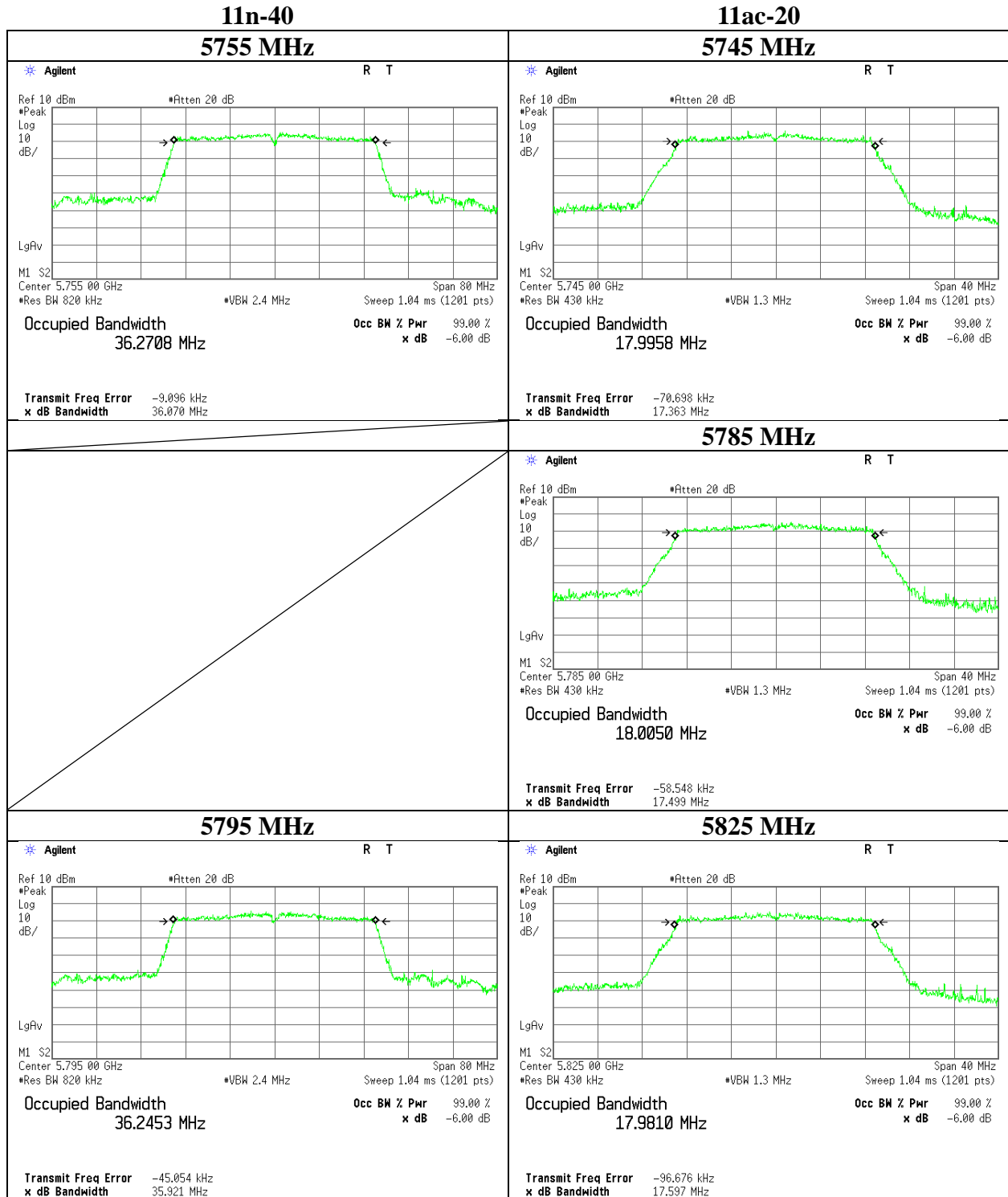

**99 % Occupied Bandwidth**

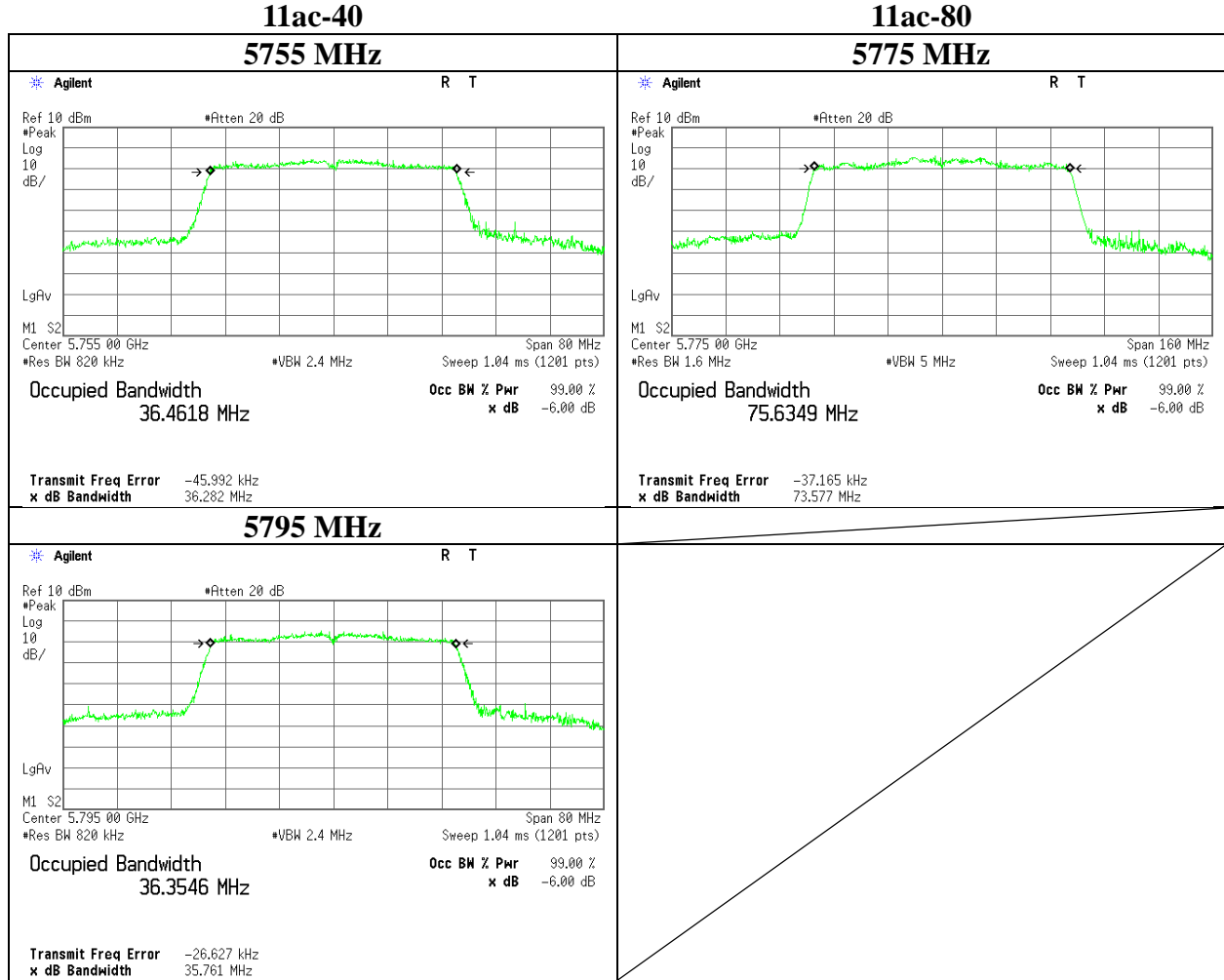

## 6 dB Bandwidth

Test place Ise EMC Lab. No.6 Measurement Room  
Report No. 11500829H  
Date December 15, 2016  
Temperature / Humidity 23deg. C / 31 % RH  
Engineer Yutaka Yoshida  
Mode Tx

### 11a, 6Mbps

Tested Frequency [MHz]	6 dB Bandwidth [MHz]	Limit [kHz]
5745	16.316	> 500
5785	16.355	> 500
5825	16.350	> 500

### 11n-20, MCS7, Long GI

Tested Frequency [MHz]	6 dB Bandwidth [MHz]	Limit [kHz]
5745	17.627	> 500
5785	17.648	> 500
5825	17.691	> 500

### 11n-40, MCS5, Short GI

Tested Frequency [MHz]	6 dB Bandwidth [MHz]	Limit [kHz]
5755	36.193	> 500
5795	36.369	> 500

### 11ac-20, MCS8, Long GI

Tested Frequency [MHz]	6 dB Bandwidth [MHz]	Limit [kHz]
5745	17.677	> 500
5785	17.642	> 500
5825	17.597	> 500

### 11ac-40, MCS1, Short GI

Tested Frequency [MHz]	6 dB Bandwidth [MHz]	Limit [kHz]
5755	35.721	> 500
5795	35.854	> 500

### 11ac-80, MCS9, Long GI

Tested Frequency [MHz]	6 dB Bandwidth [MHz]	Limit [kHz]
5775	75.578	> 500

### 6 dB Bandwidth

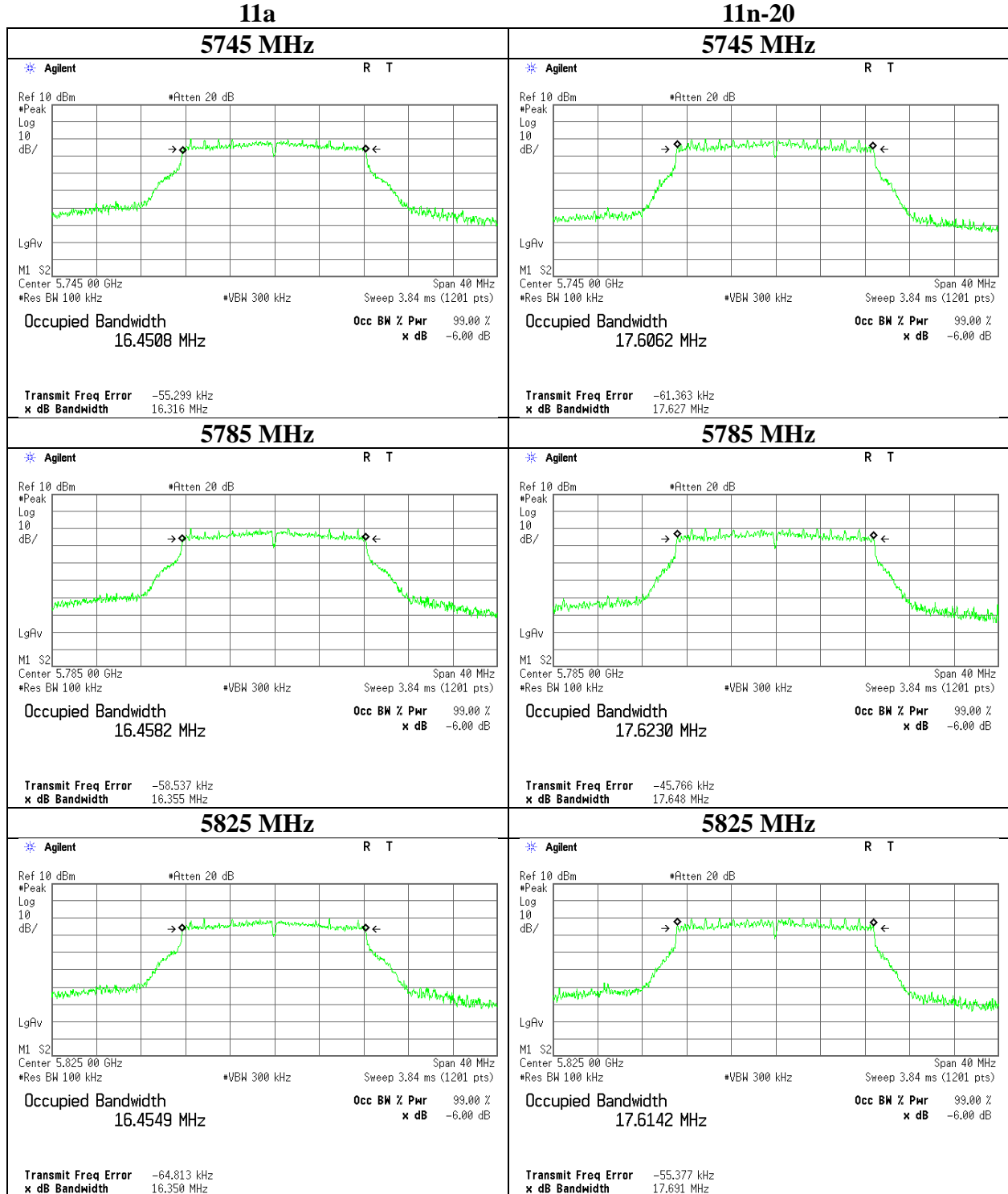

**UL Japan, Inc.**

**Ise EMC Lab.**

4383-326 Asama-cho, Ise-shi, Mie-ken 516-0021 JAPAN

Telephone : +81 596 24 8999

Facsimile : +81 596 24 8124

### 6 dB Bandwidth

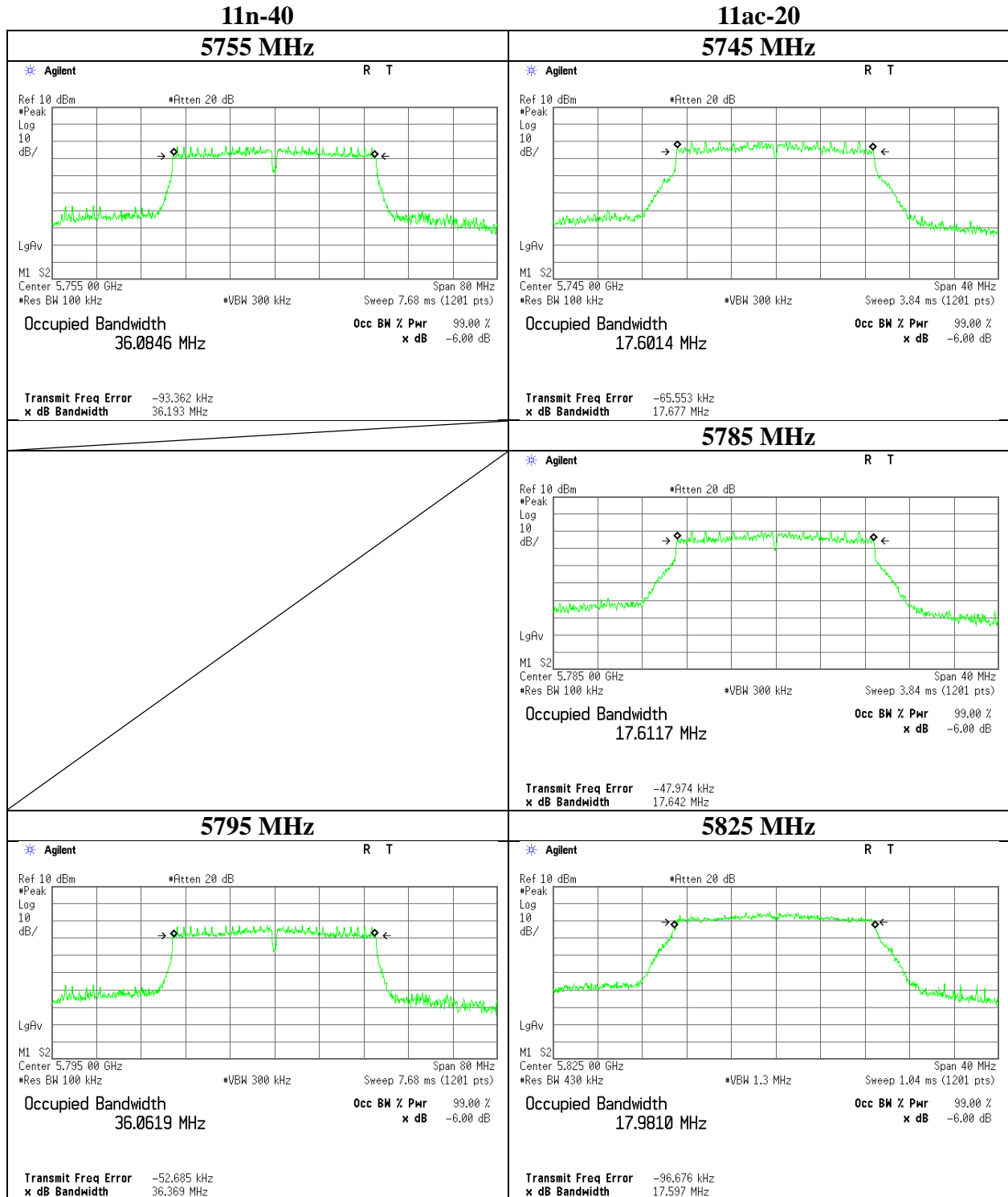

**UL Japan, Inc.**

**Ise EMC Lab.**

4383-326 Asama-cho, Ise-shi, Mie-ken 516-0021 JAPAN

Telephone : +81 596 24 8999

Facsimile : +81 596 24 8124

### 6 dB Bandwidth

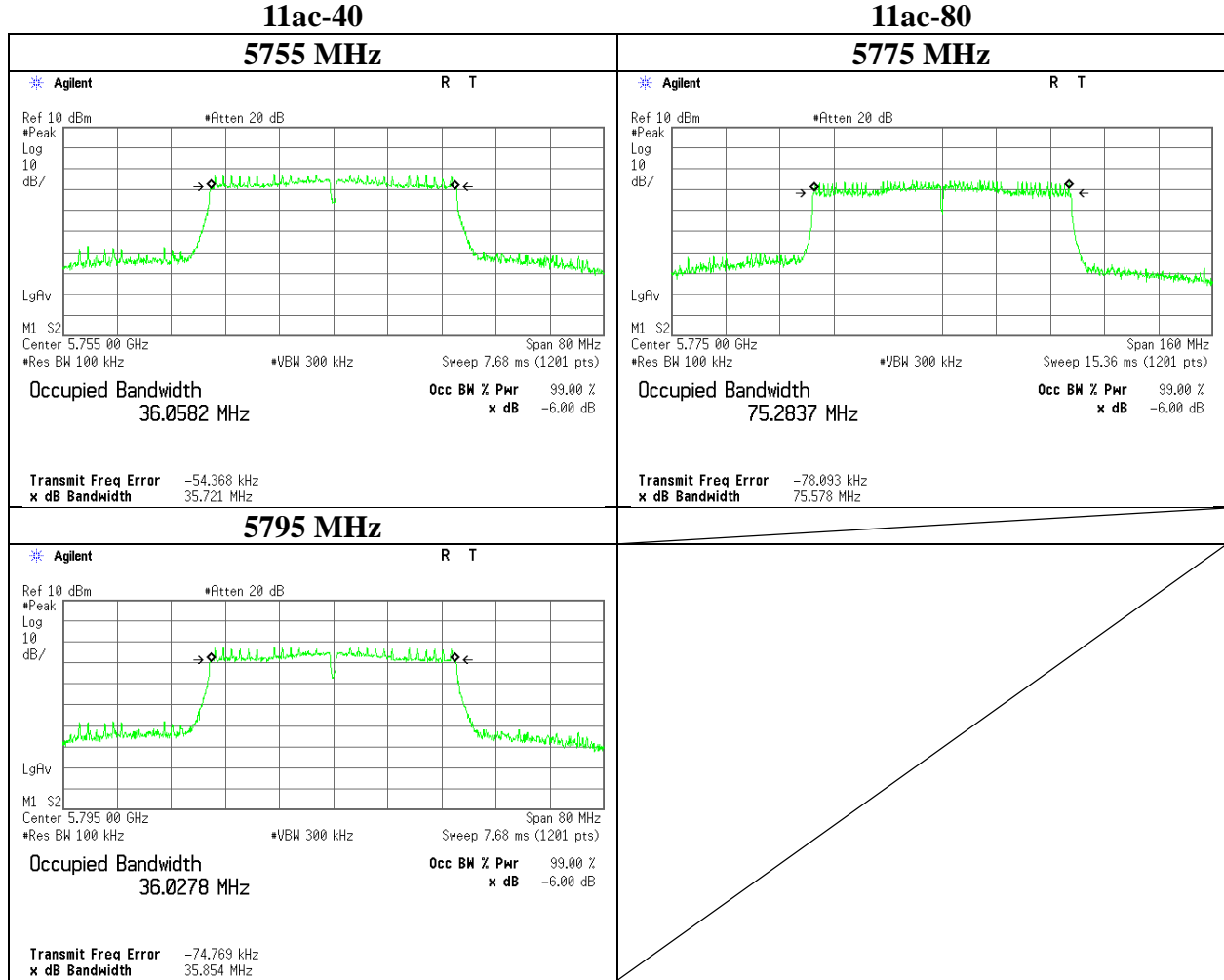

**UL Japan, Inc.**

**Ise EMC Lab.**

4383-326 Asama-cho, Ise-shi, Mie-ken 516-0021 JAPAN

Telephone : +81 596 24 8999

Facsimile : +81 596 24 8124

## Maximum Conducted Output Power

Test place : Ise EMC Lab. No.6 Measurement Room  
Report No. : 11500829H  
Date : December 14, 2016  
Temperature / Humidity : 25deg. C / 29 % RH  
Engineer : Yutaka Yoshida  
Mode : Tx

### 11a, 6Mbps

Applied limit: 15.407

Tested Frequency [MHz]	Power Meter Reading [dBm]	Cable Loss [dB]	Atten. Loss [dB]	Duty Factor [dB]	Antenna Gain [dBi]	26 dB EBW (B for FCC) [MHz]	99% OBW (B for IC) [MHz]	Conducted Power			e.i.r.p.				
								Result [dBm]	Limit [dBm]	Margin [dB]	Result [dBm]	Limit [dBm]	Margin [dB]	Result [mW]	Limit [dBm]
5745	1.04	2.08	10.12	0.29	-8.1	-	-	13.53	22.54	30.00	16.47	5.43	3.49	36.00	30.57
5785	1.16	2.08	10.12	0.29	-8.1	-	-	13.65	23.17	30.00	16.35	5.55	3.59	36.00	30.45
5825	1.20	2.09	10.11	0.29	-8.1	-	-	13.69	23.39	30.00	16.31	5.59	3.62	36.00	30.41

### 11n-20, MCS7, Long GI

Applied limit: 15.407

Tested Frequency [MHz]	Power Meter Reading [dBm]	Cable Loss [dB]	Atten. Loss [dB]	Duty Factor [dB]	Antenna Gain [dBi]	26 dB EBW (B for FCC) [MHz]	99% OBW (B for IC) [MHz]	Conducted Power			e.i.r.p.				
								Result [dBm]	Limit [dBm]	Margin [dB]	Result [dBm]	Limit [dBm]	Margin [dB]	Result [mW]	Limit [dBm]
5745	-0.80	2.08	10.12	2.02	-8.1	-	-	13.42	21.98	30.00	16.58	5.32	3.40	36.00	30.68
5785	-1.01	2.08	10.12	2.02	-8.1	-	-	13.21	20.94	30.00	16.79	5.11	3.24	36.00	30.89
5825	-0.96	2.09	10.11	2.02	-8.1	-	-	13.26	21.18	30.00	16.74	5.16	3.28	36.00	30.84

### 11n-40, MCS5, Short GI

Applied limit: 15.407

Tested Frequency [MHz]	Power Meter Reading [dBm]	Cable Loss [dB]	Atten. Loss [dB]	Duty Factor [dB]	Antenna Gain [dBi]	26 dB EBW (B for FCC) [MHz]	99% OBW (B for IC) [MHz]	Conducted Power			e.i.r.p.				
								Result [dBm]	Limit [dBm]	Margin [dB]	Result [dBm]	Limit [dBm]	Margin [dB]	Result [mW]	Limit [dBm]
5755	-1.61	2.08	10.12	2.84	-8.1	-	-	13.43	22.03	30.00	16.57	5.33	3.41	36.00	30.67
5795	-1.61	2.09	10.12	2.84	-8.1	-	-	13.44	22.03	30.00	16.56	5.34	3.42	36.00	30.66

### 11ac-20, MCS8, Long GI

Applied limit: 15.407

Tested Frequency [MHz]	Power Meter Reading [dBm]	Cable Loss [dB]	Atten. Loss [dB]	Duty Factor [dB]	Antenna Gain [dBi]	26 dB EBW (B for FCC) [MHz]	99% OBW (B for IC) [MHz]	Conducted Power			e.i.r.p.				
								Result [dBm]	Limit [dBm]	Margin [dB]	Result [dBm]	Limit [dBm]	Margin [dB]	Result [mW]	Limit [dBm]
5745	-0.94	2.08	10.12	2.18	-8.1	-	-	13.44	22.08	30.00	16.56	5.34	3.42	36.00	30.66
5785	-1.15	2.08	10.12	2.18	-8.1	-	-	13.23	21.04	30.00	16.77	5.13	3.26	36.00	30.87
5825	-1.04	2.09	10.11	2.18	-8.1	-	-	13.34	21.58	30.00	16.66	5.24	3.34	36.00	30.76

### 11ac-40, MCS1, Short GI

Applied limit: 15.407

Tested Frequency [MHz]	Power Meter Reading [dBm]	Cable Loss [dB]	Atten. Loss [dB]	Duty Factor [dB]	Antenna Gain [dBi]	26 dB EBW (B for FCC) [MHz]	99% OBW (B for IC) [MHz]	Conducted Power			e.i.r.p.				
								Result [dBm]	Limit [dBm]	Margin [dB]	Result [dBm]	Limit [dBm]	Margin [dB]	Result [mW]	Limit [dBm]
5755	0.07	2.08	10.12	1.18	-8.1	-	-	13.45	22.13	30.00	16.55	5.35	3.43	36.00	30.65
5795	0.06	2.09	10.12	1.18	-8.1	-	-	13.44	22.08	30.00	16.56	5.34	3.42	36.00	30.66

### 11ac-80, MCS9, Long GI

Applied limit: 15.407

Tested Frequency [MHz]	Power Meter Reading [dBm]	Cable Loss [dB]	Atten. Loss [dB]	Duty Factor [dB]	Antenna Gain [dBi]	26 dB EBW (B for FCC) [MHz]	99% OBW (B for IC) [MHz]	Conducted Power			e.i.r.p.				
								Result [dBm]	Limit [dBm]	Margin [dB]	Result [dBm]	Limit [dBm]	Margin [dB]	Result [mW]	Limit [dBm]
5775	-3.55	2.08	10.12	3.91	-8.1	-	-	12.56	18.03	30.00	17.44	4.46	2.79	36.00	31.54

Sample Calculation:

Conducted Power Result = Reading + Cable Loss (including the cable(s) customer supplied) + Atten. Loss + Duty Factor

### Maximum Conducted Output Power

Test place : Ise EMC Lab. No.6 Measurement Room  
Report No. : 11500829H  
Date : December 14, 2016  
Temperature / Humidity : 25deg. C / 29 % RH  
Engineer : Yutaka Yoshida  
Mode : Tx 11a

#### 5745 MHz

Mode	Rate Mbps	Reading (gated average) [dBm]	Remarks
11a	6	1.52	*
	9	1.51	
	12	1.50	
	18	1.50	
	24	1.51	
	36	1.39	
	48	1.49	
	54	1.43	

\* Worst rate

All comparison were carried out on same frequency and measurement factors.

## Maximum Conducted Output Power

Test place : Ise EMC Lab. No.6 Measurement Room  
Report No. : 11500829H  
Date : December 14, 2016  
Temperature / Humidity : 25deg. C / 29 % RH  
Engineer : Yutaka Yoshida  
Mode : Tx 11n-20

### 5745 MHz Short GI

Mode	MCS Index Number	Reading (gated average) [dBm]	Remarks
11n-20	0	1.08	
	1	1.06	
	2	1.05	
	3	1.06	
	4	1.16	
	5	1.19	
	6	1.08	
	7	1.12	

\* Worst rate

All comparison were carried out on same frequency and measurement factors.

### 5745 MHz Long GI

Mode	MCS Index Number	Reading (gated average) [dBm]	Remarks
11n-20	0	1.10	
	1	1.11	
	2	1.12	
	3	1.13	
	4	1.09	
	5	1.20	
	6	1.16	
	7	1.22	*

\* Worst rate

All comparison were carried out on same frequency and measurement factors.

## Maximum Conducted Output Power

Test place : Ise EMC Lab. No.6 Measurement Room  
Report No. : 11500829H  
Date : December 14, 2016  
Temperature / Humidity : 25deg. C / 29 % RH  
Engineer : Yutaka Yoshida  
Mode : Tx 11n-40

### 5755 MHz Short GI

Mode	MCS Index Number	Reading (gated average) [dBm]	Remarks
11n-40	0	1.07	
	1	1.21	
	2	1.11	
	3	1.10	
	4	1.15	
	5	1.31	*
	6	1.29	
	7	1.27	

\* Worst rate

All comparison were carried out on same frequency and measurement factors.

### 5755 MHz Long GI

Mode	MCS Index Number	Reading (gated average) [dBm]	Remarks
11n-40	0	1.12	
	1	1.17	
	2	1.19	
	3	1.11	
	4	1.12	
	5	1.17	
	6	1.22	
	7	1.23	

\* Worst rate

All comparison were carried out on same frequency and measurement factors.

## Maximum Conducted Output Power

Test place : Ise EMC Lab. No.6 Measurement Room  
Report No. : 11500829H  
Date : December 14, 2016  
Temperature / Humidity : 25deg. C / 29 % RH  
Engineer : Yutaka Yoshida  
Mode : Tx 11ac-20

### 5745 MHz Short GI

Mode	MCS Index Number	Reading (gated average) [dBm]	Remarks
11ac-20	0	1.12	
	1	1.14	
	2	1.17	
	3	1.14	
	4	1.21	
	5	1.18	
	6	1.18	
	7	1.10	
8	1.16		

\* Worst rate

All comparison were carried out on same frequency and measurement factors.

### 5745 MHz Long GI

Mode	MCS Index Number	Reading (gated average) [dBm]	Remarks
11ac-20	0	1.14	
	1	1.11	
	2	1.05	
	3	1.06	
	4	1.16	
	5	1.23	
	6	1.13	
	7	1.15	
8	1.28	*	

\* Worst rate

All comparison were carried out on same frequency and measurement factors.

## Maximum Conducted Output Power

Test place : Ise EMC Lab. No.6 Measurement Room  
Report No. : 11500829H  
Date : December 14, 2016  
Temperature / Humidity : 25deg. C / 29 % RH  
Engineer : Yutaka Yoshida  
Mode : Tx 11ac-40

### 5755 MHz Short GI

Mode	MCS Index Number	Reading (gated average) [dBm]	Remarks
11ac-40	0	1.10	
	1	1.25	*
	2	1.19	
	3	1.02	
	4	1.19	
	5	1.11	
	6	1.22	
	7	1.12	
	8	1.23	
	9	1.12	

\* Worst rate

All comparison were carried out on same frequency and measurement factors.

### 5755 MHz Long GI

Mode	MCS Index Number	Reading (gated average) [dBm]	Remarks
11ac-40	0	1.10	
	1	1.19	
	2	1.06	
	3	1.01	
	4	1.15	
	5	1.16	
	6	1.14	
	7	1.16	
	8	1.20	
	9	1.18	

\* Worst rate

All comparison were carried out on same frequency and measurement factors.

## Maximum Conducted Output Power

Test place	Ise EMC Lab. No.6 Measurement Room
Report No.	11500829H
Date	December 14, 2016
Temperature / Humidity	25deg. C / 29 % RH
Engineer	Yutaka Yoshida
Mode	Tx 11ac-80

### 5775 MHz Short GI

Mode	MCS Index Number	Reading (gated average) [dBm]	Remarks
11ac-80	0	-0.30	
	1	-0.37	
	2	-0.36	
	3	-0.36	
	4	-0.39	
	5	-0.37	
	6	-0.36	
	7	-0.31	
	8	-0.27	
	9	-0.26	

\* Worst rate

All comparison were carried out on same frequency and measurement factors.

### 5775 MHz Long GI

Mode	MCS Index Number	Reading (gated average) [dBm]	Remarks
11ac-80	0	-0.38	
	1	-0.33	
	2	-0.38	
	3	-0.30	
	4	-0.45	
	5	-0.33	
	6	-0.23	
	7	-0.46	
	8	-0.25	
	9	-0.22	*

\* Worst rate

All comparison were carried out on same frequency and measurement factors.

**UL Japan, Inc.**

**Ise EMC Lab.**

4383-326 Asama-cho, Ise-shi, Mie-ken 516-0021 JAPAN

Telephone : +81 596 24 8999

Facsimile : +81 596 24 8124

**Average Output Power**  
**(Reference data for RF Exposure)**

Test place : Ise EMC Lab. No.6 Measurement Room  
Report No. : 11500829H  
Date : December 14, 2016  
Temperature / Humidity : 25deg. C / 29 % RH  
Engineer : Yutaka Yoshida  
Mode : Tx 11a / Tx 11n-20

**6Mbps**

Tested Frequency [MHz]	Power Meter Reading [dBm]	Cable Loss [dB]	Atten. Loss [dB]	Result (Timed average)		Duty factor [dB]	Result (Burst power average)	
				[dBm]	[mW]		[dBm]	[mW]
5745	1.04	2.08	10.12	13.24	21.09	0.29	13.53	22.54
5785	1.16	2.08	10.12	13.36	21.68	0.29	13.65	23.17
5825	1.20	2.09	10.11	13.40	21.88	0.29	13.69	23.39

Sample Calculation:

Result (Timed average) = Reading + Cable Loss (including the cable(s) customer supplied) + Atten. Loss

Result (Burst power average) = Time average + Duty factor

**11n-20 MCS0 Long GI**

Tested Frequency [MHz]	Power Meter Reading [dBm]	Cable Loss [dB]	Atten. Loss [dB]	Result (Timed average)		Duty factor [dB]	Result (Burst power average)	
				[dBm]	[mW]		[dBm]	[mW]
5745	0.80	2.08	10.12	13.00	19.95	0.30	13.30	21.38
5785	0.74	2.08	10.12	12.94	19.68	0.30	13.24	21.09
5825	0.71	2.09	10.11	12.91	19.54	0.30	13.21	20.94

Sample Calculation:

Result (Timed average) = Reading + Cable Loss (including the cable(s) customer supplied) + Atten. Loss

Result (Burst power average) = Time average + Duty factor

**The average output power was measured with the lowest order modulation and lowest data rate configuration in each IEEE 802.11 mode based on KDB 248227 D01.**

**Average Output Power**  
**(Reference data for RF Exposure)**

Test place : Ise EMC Lab. No.6 Measurement Room  
Report No. : 11500829H  
Date : December 14, 2016  
Temperature / Humidity : 25deg. C / 29 % RH  
Engineer : Yutaka Yoshida  
Mode : Tx 11n-40 / Tx 11ac-20

**11n-40 MCS0 Long GI**

Tested Frequency [MHz]	Power Meter Reading [dBm]	Cable Loss [dB]	Atten. Loss [dB]	Result (Timed average)		Duty factor [dB]	Result (Burst power average)	
				[dBm]	[mW]		[dBm]	[mW]
5755	0.53	2.08	10.12	12.73	18.75	0.60	13.33	21.53
5795	0.54	2.09	10.12	12.74	18.79	0.60	13.34	21.58

Sample Calculation:

Result (Timed average) = Reading + Cable Loss (including the cable(s) customer supplied) + Atten. Loss

Result (Burst power average) = Time average + Duty factor

**11ac-20 MCS0 Long GI**

Tested Frequency [MHz]	Power Meter Reading [dBm]	Cable Loss [dB]	Atten. Loss [dB]	Result (Timed average)		Duty factor [dB]	Result (Burst power average)	
				[dBm]	[mW]		[dBm]	[mW]
5745	0.81	2.08	10.12	13.01	20.00	0.31	13.32	21.48
5785	0.82	2.08	10.12	13.02	20.04	0.31	13.33	21.53
5825	0.80	2.09	10.11	13.00	19.95	0.31	13.31	21.43

Sample Calculation:

Result (Timed average) = Reading + Cable Loss (including the cable(s) customer supplied) + Atten. Loss

Result (Burst power average) = Time average + Duty factor

**The average output power was measured with the lowest order modulation and lowest data rate configuration in each IEEE 802.11 mode based on KDB 248227 D01.**

**Average Output Power**  
**(Reference data for RF Exposure)**

Test place : Ise EMC Lab. No.6 Measurement Room  
Report No. : 11500829H  
Date : December 14, 2016  
Temperature / Humidity : 25deg. C / 29 % RH  
Engineer : Yutaka Yoshida  
Mode : Tx 11ac-40 / Tx 11ac-80

**11ac-40 MCS0 Long GI**

Tested Frequency [MHz]	Power Meter Reading [dBm]	Cable Loss [dB]	Atten. Loss [dB]	Result (Timed average)		Duty factor [dB]	Result (Burst power average)	
				[dBm]	[mW]		[dBm]	[mW]
5755	0.46	2.08	10.12	12.66	18.45	0.59	13.25	21.13
5795	0.59	2.09	10.12	12.79	19.01	0.59	13.38	21.78

Sample Calculation:

Result (Timed average) = Reading + Cable Loss (including the cable(s) customer supplied) + Atten. Loss

Result (Burst power average) = Time average + Duty factor

**11ac-80 MCS0 Long GI**

Tested Frequency [MHz]	Power Meter Reading [dBm]	Cable Loss [dB]	Atten. Loss [dB]	Result (Timed average)		Duty factor [dB]	Result (Burst power average)	
				[dBm]	[mW]		[dBm]	[mW]
5775	-1.00	2.08	10.12	11.20	13.18	1.11	12.31	17.02

Sample Calculation:

Result (Timed average) = Reading + Cable Loss (including the cable(s) customer supplied) + Atten. Loss

Result (Burst power average) = Time average + Duty factor

**The average output power was measured with the lowest order modulation and lowest data rate configuration in each IEEE 802.11 mode based on KDB 248227 D01.**

### Burst rate confirmation

Test place	Ise EMC Lab. No.6 Measurement Room
Report No.	11500829H
Date	December 14, 2016
Temperature / Humidity	25deg. C / 29 % RH
Engineer	Yutaka Yoshida
Mode	Tx

#### 11a 6Mbps

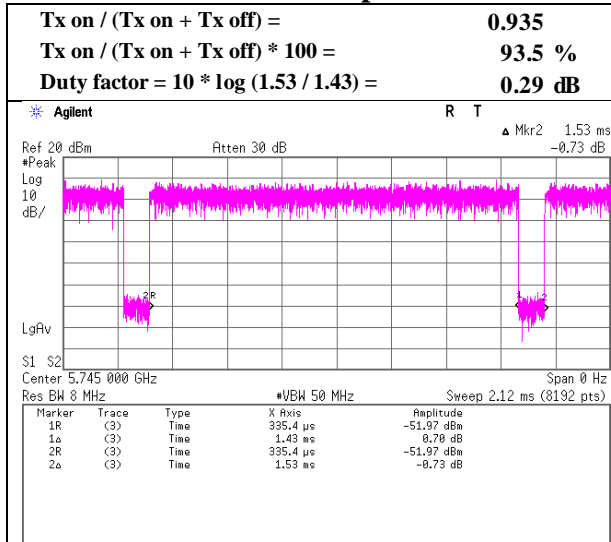

#### 11n-20 MCS0, Long GI

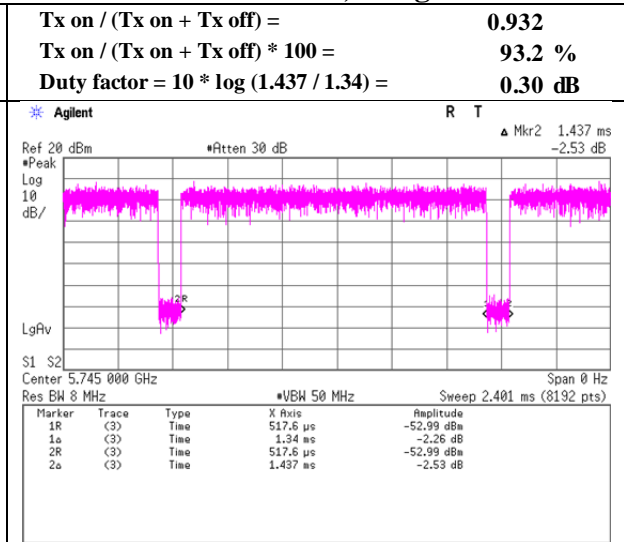

#### 11n-20 MCS7, Long GI

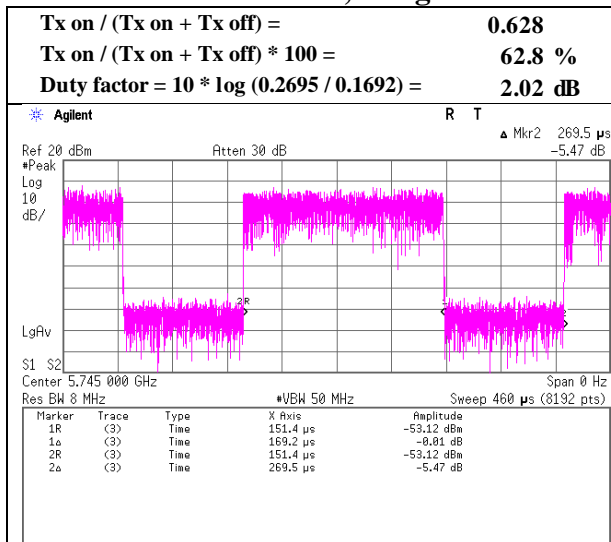

#### 11n-40 MCS0, Long GI

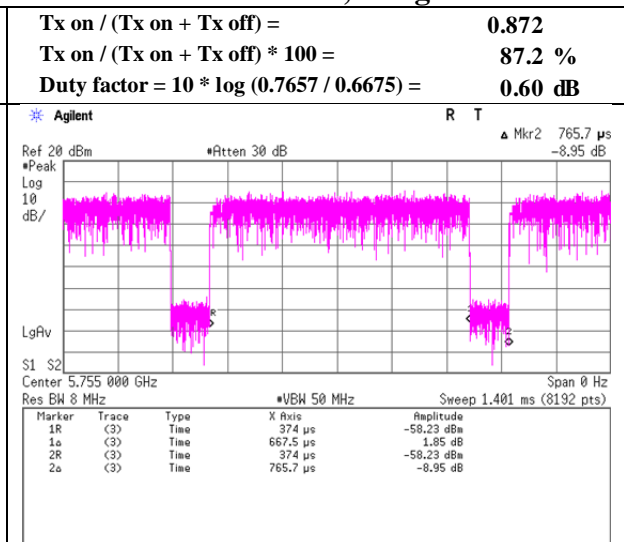

### Burst rate confirmation

Test place	Ise EMC Lab. No.6 Measurement Room
Report No.	11500829H
Date	December 14, 2016
Temperature / Humidity	25deg. C / 29 % RH
Engineer	Yutaka Yoshida
Mode	Tx

#### 11n-40 MCS5, Short GI

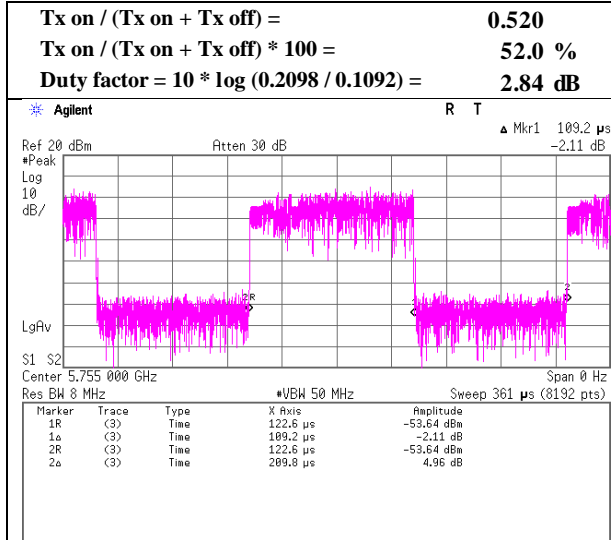

#### 11ac-20 MCS0, Long GI

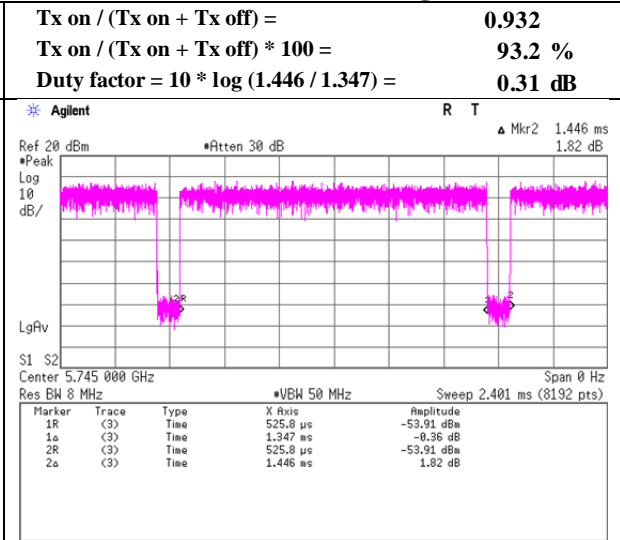

#### 11ac-20 MCS8, Long GI

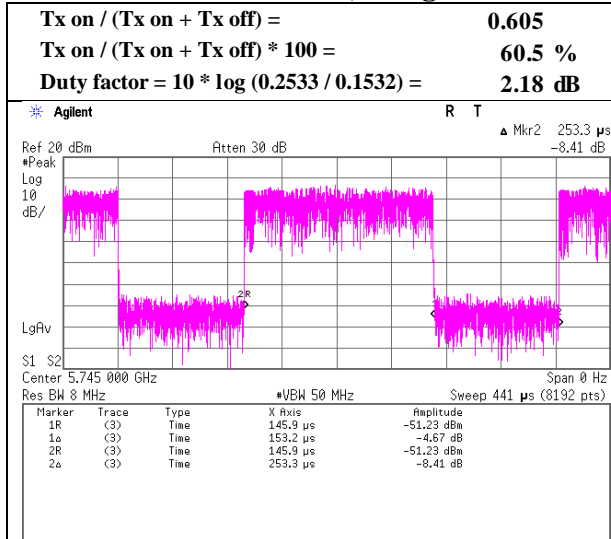

#### 11ac40 MCS0, Long GI

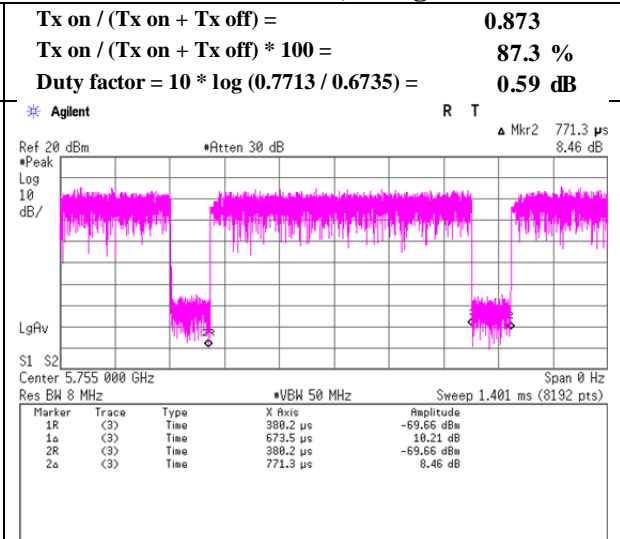

### Burst rate confirmation

Test place	Ise EMC Lab. No.6 Measurement Room
Report No.	11500829H
Date	December 14, 2016
Temperature / Humidity	25deg. C / 29 % RH
Engineer	Yutaka Yoshida
Mode	Tx

#### 11ac-40 MCS1, Short GI

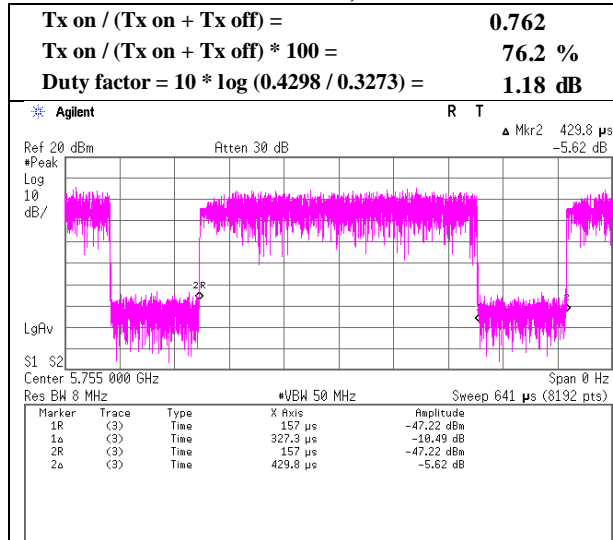

#### 11ac-80 MCS0 Long GI

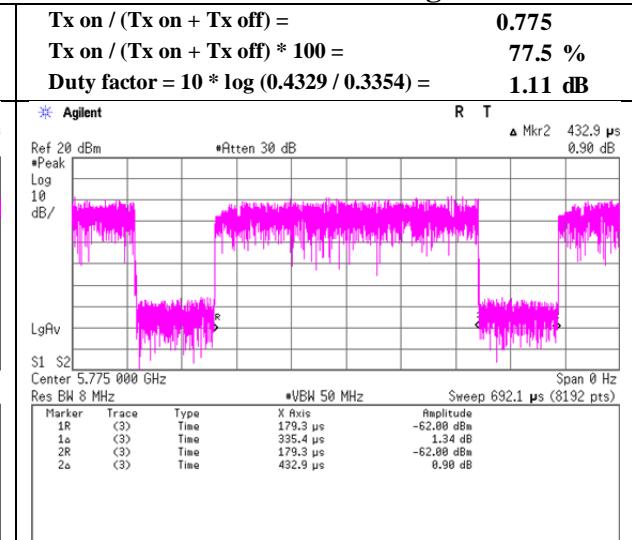

#### 11ac80 MCS9, Long GI

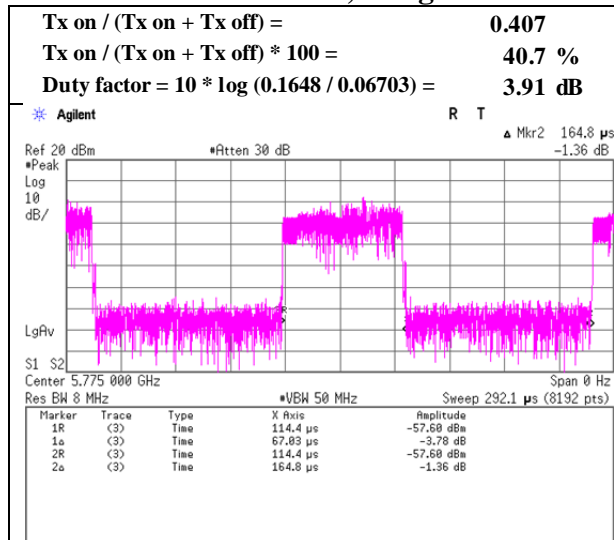

## Maximum Power Spectral Density

Test place : Ise EMC Lab. No.6 Measurement Room  
Report No. : 11500829H  
Date : December 15, 2016  
Temperature / Humidity : 23deg. C / 31 % RH  
Engineer : Yutaka Yoshida  
Mode : Tx 11a / Tx 11n-20

### 11a, 6Mbps

Applied limit: 15.407

Tested Frequency [MHz]	PSD Reading [dBm /MHz]	Cable Loss [dB]	Atten. Loss [dB]	Duty Factor [dB]	Antenna Gain [dBi]	RBW Correction Factor [dB]	PSD (Conducted)			PSD (e.i.r.p.)		
							Result [dBm /MHz]	Limit [dBm /MHz]	Margin [dB]	Result [dBm /MHz]	Limit [dBm /MHz]	Margin [dB]
5745	-11.75	2.08	10.12	0.29	-8.1	0.27	1.01	30.00	28.99	-7.09	36.00	43.09
5785	-11.51	2.08	10.12	0.29	-8.1	0.27	1.25	30.00	28.75	-6.85	36.00	42.85
5825	-11.70	2.09	10.11	0.29	-8.1	0.27	1.07	30.00	28.93	-7.03	36.00	43.03

Sample Calculation:

PSD: Power Spectral Density

The PSD within 5725 MHz to 5825 MHz are based on any 500 kHz band.

RBW Correction Factor =  $10 * \log (\text{Specified bandwidth} / \text{Measured bandwidth})$

PSD Result (Conducted) = Reading + Cable Loss (including the cable(s) customer supplied) + Atten. Loss + Duty Factor + RBW Correction Factor

PSD Result (e.i.r.p.) = Conducted PSD Result + Antenna Gain

### 11n-20, MCS7, Long GI

Applied limit: 15.407

Tested Frequency [MHz]	PSD Reading [dBm /MHz]	Cable Loss [dB]	Atten. Loss [dB]	Duty Factor [dB]	Antenna Gain [dBi]	RBW Correction Factor [dB]	PSD (Conducted)			PSD (e.i.r.p.)		
							Result [dBm /MHz]	Limit [dBm /MHz]	Margin [dB]	Result [dBm /MHz]	Limit [dBm /MHz]	Margin [dB]
5745	-14.08	2.08	10.12	2.02	-8.1	0.27	0.41	30.00	29.59	-7.69	36.00	43.69
5785	-13.87	2.08	10.12	2.02	-8.1	0.27	0.62	30.00	29.38	-7.48	36.00	43.48
5825	-13.99	2.09	10.11	2.02	-8.1	0.27	0.51	30.00	29.49	-7.59	36.00	43.59

Sample Calculation:

PSD: Power Spectral Density

The PSD within 5725 MHz to 5825 MHz are based on any 500 kHz band.

RBW Correction Factor =  $10 * \log (\text{Specified bandwidth} / \text{Measured bandwidth})$

PSD Result (Conducted) = Reading + Cable Loss (including the cable(s) customer supplied) + Atten. Loss + Duty Factor + RBW Correction Factor

PSD Result (e.i.r.p.) = Conducted PSD Result + Antenna Gain

## Maximum Power Spectral Density

Test place	Ise EMC Lab. No.6 Measurement Room
Report No.	11500829H
Date	December 15, 2016
Temperature / Humidity	23deg. C / 31 % RH
Engineer	Yutaka Yoshida
Mode	Tx 11a / Tx 11n-20

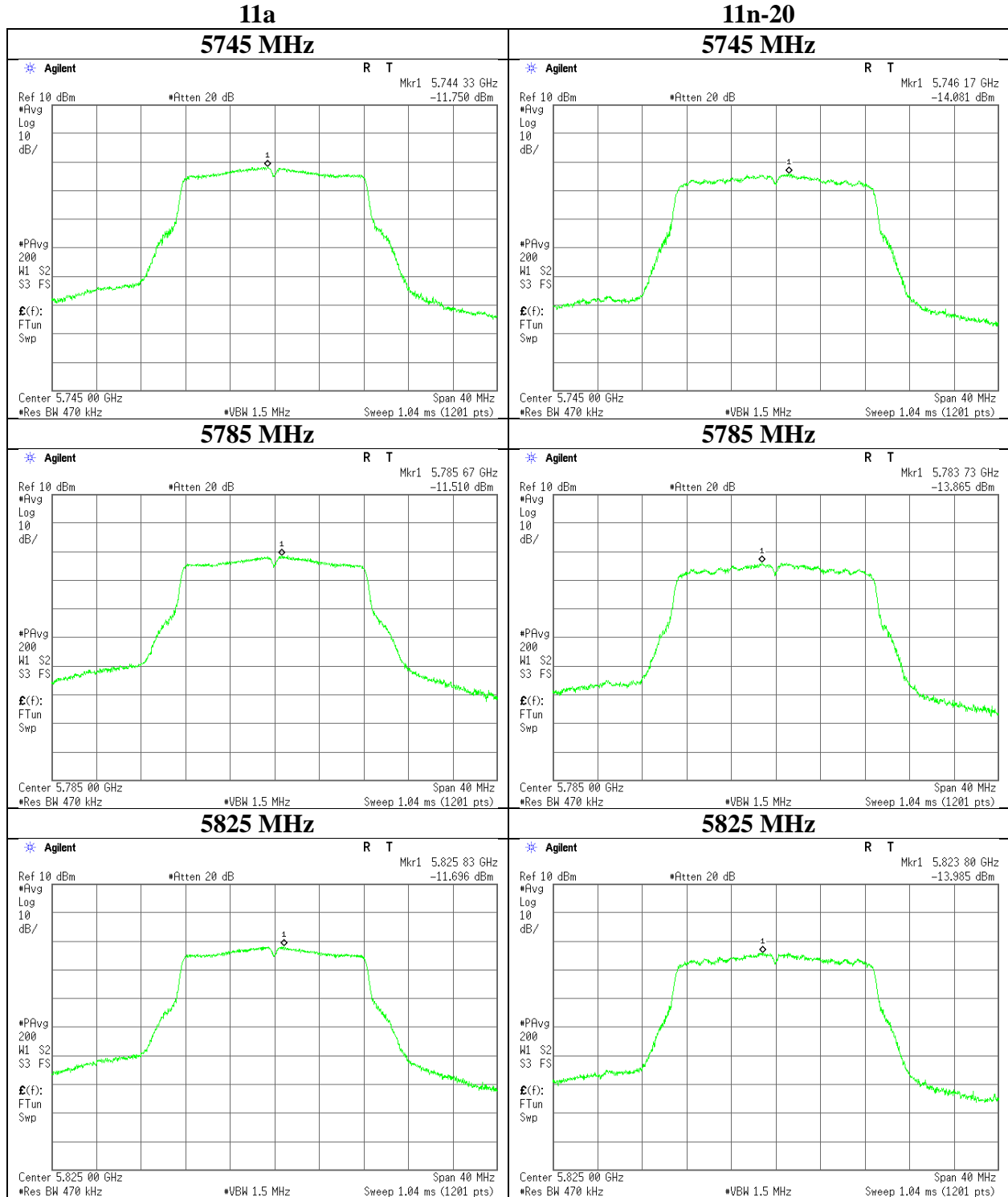

## Maximum Power Spectral Density

Test place : Ise EMC Lab. No.6 Measurement Room  
Report No. : 11500829H  
Date : December 15, 2016  
Temperature / Humidity : 23deg. C / 31 % RH  
Engineer : Yutaka Yoshida  
Mode : Tx 11n-40 / Tx 11ac-20

### 11n-40, MCS5, Short GI

Applied limit: 15.407

Tested Frequency [MHz]	PSD Reading [dBm /MHz]	Cable Loss [dB]	Atten. Loss [dB]	Duty Factor [dB]	Antenna Gain [dBi]	RBW Correction Factor [dB]	PSD (Conducted)			PSD (e.i.r.p.)		
							Result [dBm /MHz]	Limit [dBm /MHz]	Margin [dB]	Result [dBm /MHz]	Limit [dBm /MHz]	Margin [dB]
5755	-17.82	2.08	10.12	2.84	-8.1	0.27	-2.51	30.00	32.51	-10.61	36.00	46.61
5795	-17.48	2.09	10.12	2.84	-8.1	0.27	-2.17	30.00	32.17	-10.27	36.00	46.27

Sample Calculation:

PSD: Power Spectral Density

The PSD within 5725 MHz to 5825 MHz are based on any 500 kHz band.

RBW Correction Factor =  $10 * \log(\text{Specified bandwidth} / \text{Measured bandwidth})$

PSD Result (Conducted) = Reading + Cable Loss (including the cable(s) customer supplied) + Atten. Loss + Duty Factor + RBW Correction Factor

PSD Result (e.i.r.p.) = Conducted PSD Result + Antenna Gain

### 11ac-20, MCS8, Long GI

Applied limit: 15.407

Tested Frequency [MHz]	PSD Reading [dBm /MHz]	Cable Loss [dB]	Atten. Loss [dB]	Duty Factor [dB]	Antenna Gain [dBi]	RBW Correction Factor [dB]	PSD (Conducted)			PSD (e.i.r.p.)		
							Result [dBm /MHz]	Limit [dBm /MHz]	Margin [dB]	Result [dBm /MHz]	Limit [dBm /MHz]	Margin [dB]
5745	-13.97	2.08	10.12	2.18	-8.1	0.27	0.68	30.00	29.32	-7.42	36.00	43.42
5785	-13.75	2.08	10.12	2.18	-8.1	0.27	0.90	30.00	29.10	-7.20	36.00	43.20
5825	-14.07	2.09	10.11	2.18	-8.1	0.27	0.58	30.00	29.42	-7.52	36.00	43.52

Sample Calculation:

PSD: Power Spectral Density

The PSD within 5725 MHz to 5825 MHz are based on any 500 kHz band.

RBW Correction Factor =  $10 * \log(\text{Specified bandwidth} / \text{Measured bandwidth})$

PSD Result (Conducted) = Reading + Cable Loss (including the cable(s) customer supplied) + Atten. Loss + Duty Factor + RBW Correction Factor

PSD Result (e.i.r.p.) = Conducted PSD Result + Antenna Gain

### Maximum Power Spectral Density

Test place	Ise EMC Lab. No.6 Measurement Room
Report No.	11500829H
Date	December 15, 2016
Temperature / Humidity	23deg. C / 31 % RH
Engineer	Yutaka Yoshida
Mode	Tx 11n-40 / Tx 11ac-20

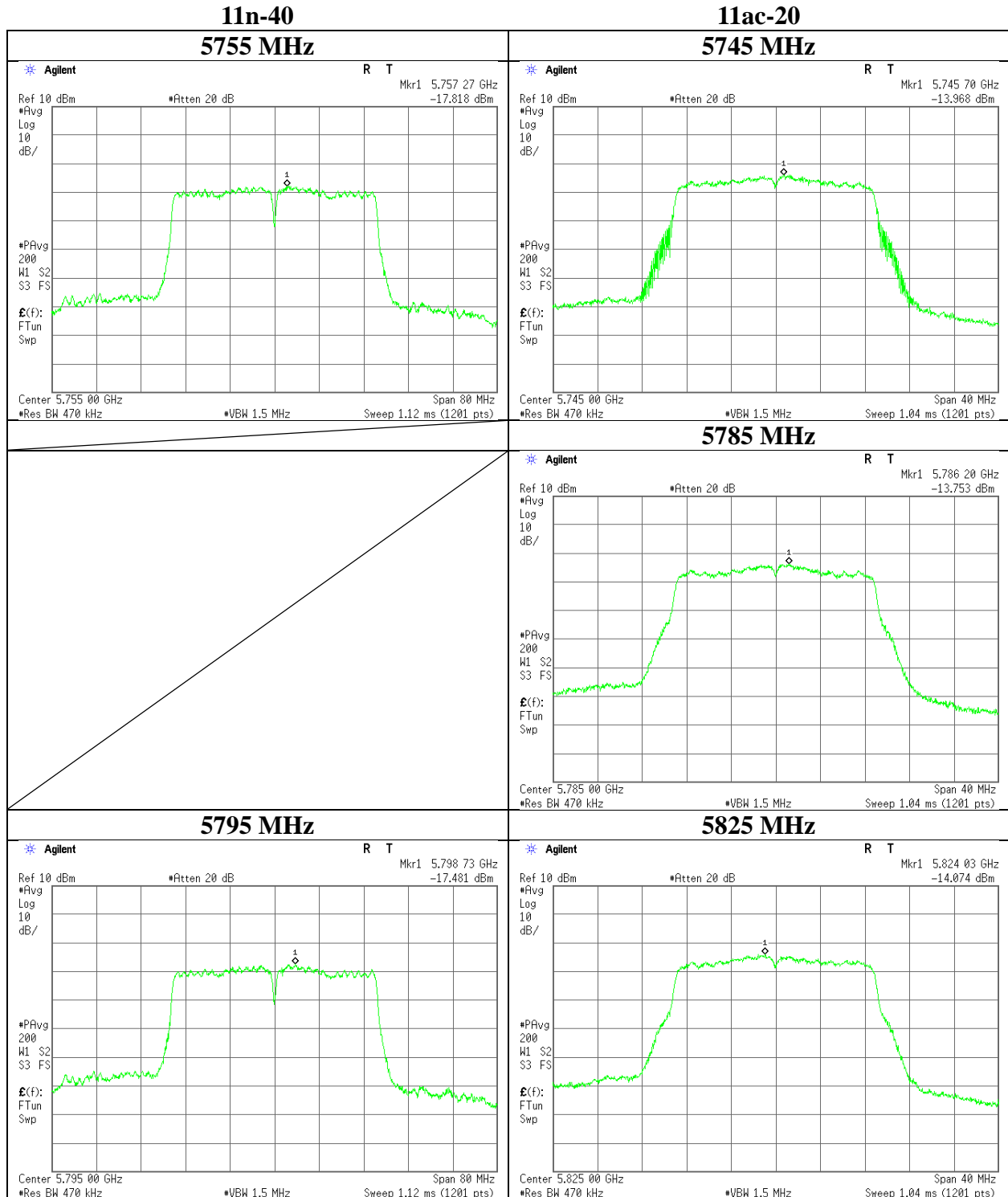

## Maximum Power Spectral Density

Test place : Ise EMC Lab. No.6 Measurement Room  
Report No. : 11500829H  
Date : December 15, 2016  
Temperature / Humidity : 23deg. C / 31 % RH  
Engineer : Yutaka Yoshida  
Mode : Tx 11ac-40 / Tx 11ac-80

### 11ac-40, MCS1, Short GI

Applied limit: 15.407

Tested Frequency [MHz]	PSD Reading [dBm /MHz]	Cable Loss [dB]	Atten. Loss [dB]	Duty Factor [dB]	Antenna Gain [dBi]	RBW Correction Factor [dB]	PSD (Conducted)			PSD (e.i.r.p.)		
							Result [dBm /MHz]	Limit [dBm /MHz]	Margin [dB]	Result [dBm /MHz]	Limit [dBm /MHz]	Margin [dB]
5755	-16.30	2.08	10.12	1.18	-8.1	0.27	-2.66	30.00	32.66	-10.76	36.00	46.76
5795	-16.68	2.09	10.12	1.18	-8.1	0.27	-3.02	30.00	33.02	-11.12	36.00	47.12

Sample Calculation:

PSD: Power Spectral Density

The PSD within 5725 MHz to 5825 MHz are based on any 500 kHz band.

RBW Correction Factor =  $10 * \log(\text{Specified bandwidth} / \text{Measured bandwidth})$

PSD Result (Conducted) = Reading + Cable Loss (including the cable(s) customer supplied) + Atten. Loss + Duty Factor + RBW Correction Factor

PSD Result (e.i.r.p.) = Conducted PSD Result + Antenna Gain

### 11ac-80, MCS9, Long GI

Applied limit: 15.407

Tested Frequency [MHz]	PSD Reading [dBm /MHz]	Cable Loss [dB]	Atten. Loss [dB]	Duty Factor [dB]	Antenna Gain [dBi]	RBW Correction Factor [dB]	PSD (Conducted)			PSD (e.i.r.p.)		
							Result [dBm /MHz]	Limit [dBm /MHz]	Margin [dB]	Result [dBm /MHz]	Limit [dBm /MHz]	Margin [dB]
5775	-21.68	2.08	10.12	3.91	-8.1	0.27	-5.30	30.00	35.30	-13.40	36.00	49.40

Sample Calculation:

PSD: Power Spectral Density

The PSD within 5725 MHz to 5825 MHz are based on any 500 kHz band.

RBW Correction Factor =  $10 * \log(\text{Specified bandwidth} / \text{Measured bandwidth})$

PSD Result (Conducted) = Reading + Cable Loss (including the cable(s) customer supplied) + Atten. Loss + Duty Factor + RBW Correction Factor

PSD Result (e.i.r.p.) = Conducted PSD Result + Antenna Gain

## Maximum Power Spectral Density

Test place	Ise EMC Lab. No.6 Measurement Room
Report No.	11500829H
Date	December 15, 2016
Temperature / Humidity	23deg. C / 31 % RH
Engineer	Yutaka Yoshida
Mode	Tx 11ac-40 / Tx 11ac-80

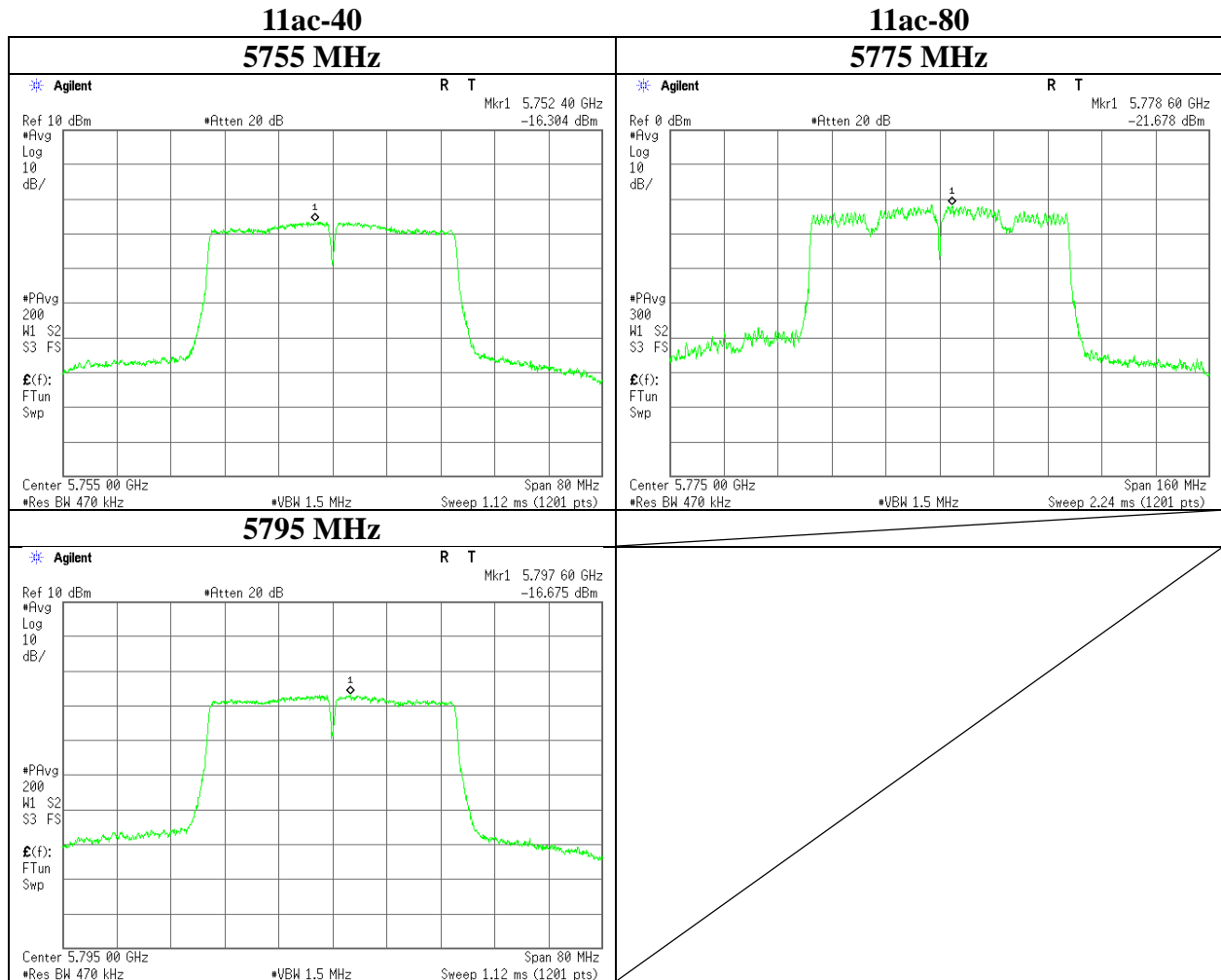

## Radiated Spurious Emission

Test place : Ise EMC Lab. No.3 Semi Anechoic Chamber  
Report No. : 11500829H  
Date : December 20, 2016      December 21, 2016      December 22, 2016  
Temperature / Humidity : 22deg. C / 37 % RH      25deg. C / 33 % RH      23deg. C / 40 % RH  
Engineer : Tomoki Matsui      Tomoki Matsui      Keisuke Kawamura  
            (1 GHz - 10 GHz)      (10 GHz - 26.5 GHz)      (26.5 GHz - 40 GHz)  
Mode : Tx 11a 5745 MHz

Polarity	Frequency [MHz]	Detector	Reading [dBuV]	Ant.Fac. [dB/m]	Loss [dB]	Gain [dB]	Duty Factor [dB]	Result [dBuV/m]	Limit [dBuV/m]	Margin [dB]	Remark
Hori	1050.000	PK	58.9	23.7	5.2	35.2	-	52.6	73.9	21.3	
Hori	1150.000	PK	58.7	24.1	5.3	34.9	-	53.2	73.9	20.7	
Hori	1250.000	PK	53.3	24.4	5.4	34.6	-	48.5	73.9	25.4	
Hori	3830.000	PK	45.8	28.9	6.9	32.0	-	49.6	73.9	24.3	
Hori	5650.000	PK	39.8	31.3	7.7	31.8	-	47.0	68.2	21.2	
Hori	5700.000	PK	43.6	31.4	7.7	31.8	-	50.9	105.2	54.3	
Hori	5715.000	PK	49.7	31.4	7.7	31.8	-	57.0	109.4	52.4	
Hori	5720.000	PK	55.9	31.4	7.7	31.8	-	63.2	110.8	47.6	
Hori	5725.000	PK	56.2	31.4	7.7	31.8	-	63.5	122.2	58.7	
Hori	11490.000	PK	41.7	39.1	-1.6	33.4	-	45.8	73.9	28.1	Floor noise
Hori	17235.000	PK	42.9	42.2	0.2	32.7	-	52.6	73.9	21.3	Floor noise
Hori	22980.000	PK	43.4	39.7	-0.5	32.3	-	50.3	73.9	23.6	Floor noise
Hori	1050.000	AV	57.4	23.7	5.2	35.2	-	51.1	53.9	2.8	
Hori	1150.000	AV	57.4	24.1	5.3	34.9	-	51.9	53.9	2.0	
Hori	1250.000	AV	50.8	24.4	5.4	34.6	-	46.0	53.9	7.9	
Hori	3830.000	AV	40.6	28.9	6.9	32.0	0.3	44.7	53.9	9.2	
Hori	11490.000	AV	32.6	39.1	-1.6	33.4	-	36.7	53.9	17.2	Floor noise
Hori	17235.000	AV	33.8	42.2	0.2	32.7	-	43.5	53.9	10.4	Floor noise
Hori	22980.000	AV	34.7	39.7	-0.5	32.3	-	41.6	53.9	12.3	Floor noise
Vert	1050.000	PK	57.0	23.7	5.2	35.2	-	50.7	73.9	23.2	
Vert	1150.000	PK	56.9	24.1	5.3	34.9	-	51.4	73.9	22.5	
Vert	1250.000	PK	53.1	24.4	5.4	34.6	-	48.3	73.9	25.6	
Vert	3830.000	PK	44.6	28.9	6.9	32.0	-	48.4	73.9	25.5	
Vert	5650.000	PK	40.6	31.3	7.7	31.8	-	47.8	68.2	20.4	
Vert	5700.000	PK	44.3	31.4	7.7	31.8	-	51.6	105.2	53.6	
Vert	5715.000	PK	51.8	31.4	7.7	31.8	-	59.1	109.4	50.3	
Vert	5720.000	PK	57.9	31.4	7.7	31.8	-	65.2	110.8	45.6	
Vert	5725.000	PK	57.1	31.4	7.7	31.8	-	64.4	122.2	57.8	
Vert	11490.000	PK	41.7	39.1	-1.6	33.4	-	45.8	73.9	28.1	Floor noise
Vert	17235.000	PK	42.9	42.2	0.2	32.7	-	52.6	73.9	21.3	Floor noise
Vert	22980.000	PK	43.4	39.7	-0.5	32.3	-	50.3	73.9	23.6	Floor noise
Vert	1050.000	AV	55.3	23.7	5.2	35.2	-	49.0	53.9	4.9	
Vert	1150.000	AV	55.6	24.1	5.3	34.9	-	50.1	53.9	3.8	
Vert	1250.000	AV	50.3	24.4	5.4	34.6	-	45.5	53.9	8.4	
Vert	3830.000	AV	38.8	28.9	6.9	32.0	0.3	42.9	53.9	11.0	
Vert	11490.000	AV	32.6	39.1	-1.6	33.4	-	36.7	53.9	17.2	Floor noise
Vert	17235.000	AV	33.8	42.2	0.2	32.7	-	43.5	53.9	10.4	Floor noise
Vert	22980.000	AV	34.7	39.7	-0.5	32.3	-	41.6	53.9	12.3	Floor noise

Result = Reading + Ant Factor + Loss (Cable+Attenuator+Filter+Distance factor(above 1 GHz)) - Gain(Amplifier) + Duty factor

\*Other frequency noises omitted in this report were not seen or had enough margin (more than 20 dB).

Distance factor:      1 GHz - 10 GHz      20log (4.45 m / 3.0 m) = 3.43 dB  
                            10 GHz - 40 GHz      20log (1.0 m / 3.0 m) = -9.5 dB

**UL Japan, Inc.**

**Ise EMC Lab.**

4383-326 Asama-cho, Ise-shi, Mie-ken 516-0021 JAPAN

Telephone : +81 596 24 8999

Facsimile : +81 596 24 8124

## Radiated Spurious Emission

Test place	Ise EMC Lab. No.3 Semi Anechoic Chamber
Report No.	11500829H
Date	December 20, 2016
Temperature / Humidity	22deg. C / 37 % RH
Engineer	Tomoki Matsui
Mode	Tx 11a 5745 MHz

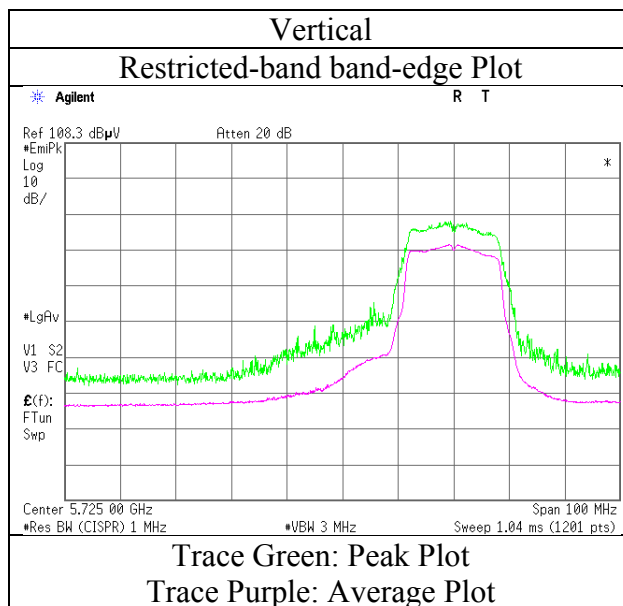
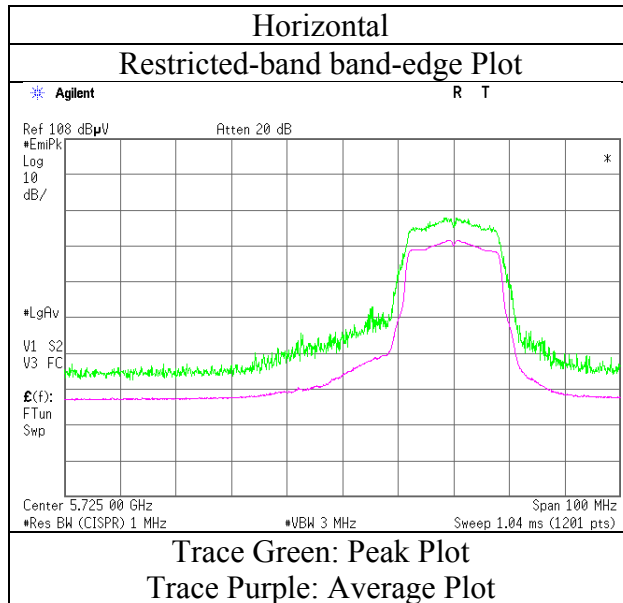

\* Final result of restricted band edge was shown in tabular data.

## Radiated Spurious Emission

Test place : Ise EMC Lab. No.3 Semi Anechoic Chamber  
Report No. : 11500829H  
Date : December 20, 2016      December 21, 2016      December 22, 2016  
Temperature / Humidity : 22deg. C / 37 % RH      25deg. C / 33 % RH      23deg. C / 40 % RH  
Engineer : Tomoki Matsui      Tomoki Matsui      Keisuke Kawamura  
            (1 GHz - 10 GHz)      (10 GHz - 26.5 GHz)      (26.5 GHz - 40 GHz)  
Mode : Tx 11a 5785 MHz

Polarity	Frequency [MHz]	Detector	Reading [dBuV]	Ant.Fac. [dB/m]	Loss [dB]	Gain [dB]	Duty Factor [dB]	Result [dBuV/m]	Limit [dBuV/m]	Margin [dB]	Remark
Hori	1050.000	PK	59.0	23.7	5.2	35.2	-	52.7	73.9	21.2	
Hori	1150.000	PK	58.7	24.1	5.3	34.9	-	53.2	73.9	20.7	
Hori	1250.000	PK	53.6	24.4	5.4	34.6	-	48.8	73.9	25.1	
Hori	3856.646	PK	46.0	29.0	6.9	32.0	-	49.9	73.9	24.0	
Hori	11570.000	PK	40.4	39.1	-1.6	33.4	-	44.5	73.9	29.4	Floor noise
Hori	17355.000	PK	41.6	42.8	0.3	32.7	-	52.0	73.9	21.9	Floor noise
Hori	23140.000	PK	43.9	39.6	-0.5	32.3	-	50.7	73.9	23.2	Floor noise
Hori	1050.000	AV	57.2	23.7	5.2	35.2	-	50.9	53.9	3.0	
Hori	1150.000	AV	57.4	24.1	5.3	34.9	-	51.9	53.9	2.0	
Hori	1250.000	AV	50.9	24.4	5.4	34.6	-	46.1	53.9	7.8	
Hori	3856.646	AV	41.1	29.0	6.9	32.0	0.3	45.3	53.9	8.6	
Hori	11570.000	AV	32.8	39.1	-1.6	33.4	-	36.9	53.9	17.0	Floor noise
Hori	17355.000	AV	32.8	42.8	0.3	32.7	-	43.2	53.9	10.7	Floor noise
Hori	23140.000	AV	35.4	39.6	-0.5	32.3	-	42.2	53.9	11.7	Floor noise
Vert	1050.000	PK	56.8	23.7	5.2	35.2	-	50.5	73.9	23.4	
Vert	1150.000	PK	57.0	24.1	5.3	34.9	-	51.5	73.9	22.4	
Vert	1250.000	PK	53.8	24.4	5.4	34.6	-	49.0	73.9	24.9	
Vert	3856.646	PK	45.0	29.0	6.9	32.0	-	48.9	73.9	25.0	
Vert	11570.000	PK	40.4	39.1	-1.6	33.4	-	44.5	73.9	29.4	Floor noise
Vert	17355.000	PK	41.6	42.8	0.3	32.7	-	52.0	73.9	21.9	Floor noise
Vert	23140.000	PK	43.9	39.6	-0.5	32.3	-	50.7	73.9	23.2	Floor noise
Vert	1050.000	AV	55.3	23.7	5.2	35.2	-	49.0	53.9	4.9	
Vert	1150.000	AV	55.3	24.1	5.3	34.9	-	49.8	53.9	4.1	
Vert	1250.000	AV	51.0	24.4	5.4	34.6	-	46.2	53.9	7.7	
Vert	3856.646	AV	39.7	29.0	6.9	32.0	0.3	43.9	53.9	10.0	
Vert	11570.000	AV	32.8	39.1	-1.6	33.4	-	36.9	53.9	17.0	Floor noise
Vert	17355.000	AV	32.8	42.8	0.3	32.7	-	43.2	53.9	10.7	Floor noise
Vert	23140.000	AV	35.4	39.6	-0.5	32.3	-	42.2	53.9	11.7	Floor noise

Result = Reading + Ant Factor + Loss (Cable+Attenuator+Filter+Distance factor(above 1 GHz)) - Gain(Amplifier) + Duty factor

\*Other frequency noises omitted in this report were not seen or had enough margin (more than 20 dB).

Distance factor:      1 GHz - 10 GHz      20log (4.45 m / 3.0 m) = 3.43 dB  
                                 10 GHz - 40 GHz      20log (1.0 m / 3.0 m) = -9.5 dB

## Radiated Spurious Emission

Test place : Ise EMC Lab. No.3 Semi Anechoic Chamber  
Report No. : 11500829H  
Date : December 20, 2016      December 21, 2016      December 22, 2016      December 22, 2016  
Temperature / Humidity : 22deg. C / 37 % RH      25deg. C / 33 % RH      23deg. C / 40 % RH      23deg. C / 45 % RH  
Engineer : Tomoki Matsui      Tomoki Matsui      Keisuke Kawamura      Tomoki Matsui  
            (1 GHz - 10 GHz)      (10 GHz - 26.5 GHz)      (26.5 GHz - 40 GHz)      (Below 1 GHz)  
Mode : Tx 11a 5825 MHz

Polarity	Frequency [MHz]	Detector	Reading [dBuV]	Ant.Fac. [dB/m]	Loss [dB]	Gain [dB]	Duty Factor [dB]	Result [dBuV/m]	Limit [dBuV/m]	Margin [dB]	Remark
Hori	32.940	QP	27.7	16.5	7.2	32.2	-	19.2	40.0	20.8	
Hori	39.420	QP	29.1	14.5	7.3	32.2	-	18.7	40.0	21.3	
Hori	168.000	QP	44.8	15.9	8.9	32.1	-	37.5	43.5	6.0	
Hori	180.000	QP	38.3	16.3	9.0	32.1	-	31.5	43.5	12.0	
Hori	192.000	QP	44.2	16.4	9.1	32.1	-	37.6	43.5	5.9	
Hori	196.600	QP	39.4	16.4	9.2	32.1	-	32.9	43.5	10.6	
Hori	1050.000	PK	59.2	23.7	5.2	35.2	-	52.9	73.9	21.0	
Hori	1150.000	PK	58.5	24.1	5.3	34.9	-	53.0	73.9	20.9	
Hori	1250.000	PK	52.8	24.4	5.4	34.6	-	48.0	73.9	25.9	
Hori	3883.333	PK	46.2	29.0	6.9	32.0	-	50.1	73.9	23.8	
Hori	5850.000	PK	47.5	31.6	7.7	31.8	-	55.0	122.2	67.2	
Hori	5855.000	PK	47.1	31.6	7.7	31.8	-	54.6	110.8	56.2	
Hori	5860.000	PK	44.3	31.6	7.7	31.8	-	51.8	109.4	57.6	
Hori	5875.000	PK	40.2	31.6	7.7	31.8	-	47.7	105.2	57.5	
Hori	5925.000	PK	40.8	31.6	7.7	31.8	-	48.3	68.2	19.9	
Hori	11650.000	PK	42.9	39.0	-1.4	33.4	-	47.1	73.9	26.8	Floor noise
Hori	17475.000	PK	42.5	43.5	0.4	32.7	-	53.7	73.9	20.2	Floor noise
Hori	23300.000	PK	43.3	39.5	-0.5	32.2	-	50.1	73.9	23.8	Floor noise
Hori	1050.000	AV	57.2	23.7	5.2	35.2	-	50.9	53.9	3.0	
Hori	1150.000	AV	57.2	24.1	5.3	34.9	-	51.7	53.9	2.2	
Hori	1250.000	AV	49.9	24.4	5.4	34.6	-	45.1	53.9	8.8	
Hori	3883.333	AV	42.0	29.0	6.9	32.0	0.3	46.2	53.9	7.7	
Hori	11650.000	AV	33.8	39.0	-1.4	33.4	-	38.0	53.9	15.9	Floor noise
Hori	17475.000	AV	33.7	43.5	0.4	32.7	-	44.9	53.9	9.0	Floor noise
Hori	23300.000	AV	35.0	39.5	-0.5	32.2	-	41.8	53.9	12.1	Floor noise
Vert	39.350	QP	44.4	14.5	7.3	32.2	-	34.0	40.0	6.0	
Vert	45.020	QP	44.1	12.6	7.4	32.2	-	31.9	40.0	8.1	
Vert	48.002	QP	46.4	11.5	7.4	32.2	-	33.1	40.0	6.9	
Vert	158.000	QP	33.6	15.5	8.8	32.1	-	25.8	43.5	17.7	
Vert	168.000	QP	42.8	15.9	8.9	32.1	-	35.5	43.5	8.0	
Vert	196.600	QP	35.6	16.4	9.2	32.1	-	29.1	43.5	14.4	
Vert	1050.000	PK	57.1	23.7	5.2	35.2	-	50.8	73.9	23.1	
Vert	1150.000	PK	57.3	24.1	5.3	34.9	-	51.8	73.9	22.1	
Vert	1250.000	PK	53.9	24.4	5.4	34.6	-	49.1	73.9	24.8	
Vert	3883.333	PK	44.9	29.0	6.9	32.0	-	48.8	73.9	25.1	
Vert	5850.000	PK	45.9	31.6	7.7	31.8	-	53.4	122.2	68.8	
Vert	5855.000	PK	45.7	31.6	7.7	31.8	-	53.2	110.8	57.6	
Vert	5860.000	PK	43.0	31.6	7.7	31.8	-	50.5	109.4	58.9	
Vert	5875.000	PK	40.4	31.6	7.7	31.8	-	47.9	105.2	57.3	
Vert	5925.000	PK	40.0	31.6	7.7	31.8	-	47.5	68.2	20.7	
Vert	11650.000	PK	42.9	39.0	-1.4	33.4	-	47.1	73.9	26.8	Floor noise
Vert	17475.000	PK	42.5	43.5	0.4	32.7	-	53.7	73.9	20.2	Floor noise
Vert	23300.000	PK	43.3	39.5	-0.5	32.2	-	50.1	73.9	23.8	Floor noise
Vert	1050.000	AV	55.6	23.7	5.2	35.2	-	49.3	53.9	4.6	
Vert	1150.000	AV	55.4	24.1	5.3	34.9	-	49.9	53.9	4.0	
Vert	1250.000	AV	51.0	24.4	5.4	34.6	-	46.2	53.9	7.7	
Vert	3883.333	AV	40.2	29.0	6.9	32.0	0.3	44.4	53.9	9.5	
Vert	11650.000	AV	33.8	39.0	-1.4	33.4	-	38.0	53.9	15.9	Floor noise
Vert	17475.000	AV	33.7	43.5	0.4	32.7	-	44.9	53.9	9.0	Floor noise
Vert	23300.000	AV	35.0	39.5	-0.5	32.2	-	41.8	53.9	12.1	Floor noise

Result = Reading + Ant Factor + Loss (Cable+Attenuator+Filter+Distance factor(above 1 GHz)) - Gain(Amplifier) + Duty factor  
\*Other frequency noises omitted in this report were not seen or had enough margin (more than 20 dB).

Distance factor:      1 GHz - 10 GHz      20log (4.45 m / 3.0 m) = 3.43 dB  
                             10 GHz - 40 GHz      20log (1.0 m / 3.0 m) = -9.5 dB

**UL Japan, Inc.**

**Ise EMC Lab.**

4383-326 Asama-cho, Ise-shi, Mie-ken 516-0021 JAPAN

Telephone : +81 596 24 8999

Facsimile : +81 596 24 8124

## Radiated Spurious Emission

Test place	Ise EMC Lab. No.3 Semi Anechoic Chamber
Report No.	11500829H
Date	December 20, 2016
Temperature / Humidity	22deg. C / 37 % RH
Engineer	Tomoki Matsui
Mode	Tx 11a 5825 MHz

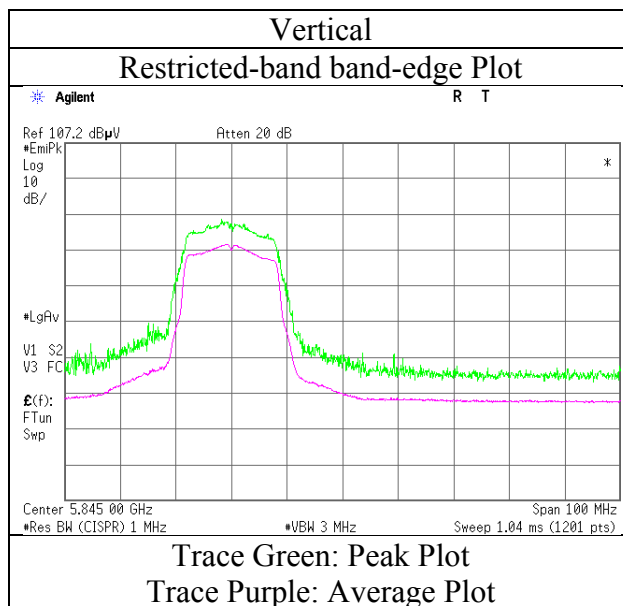
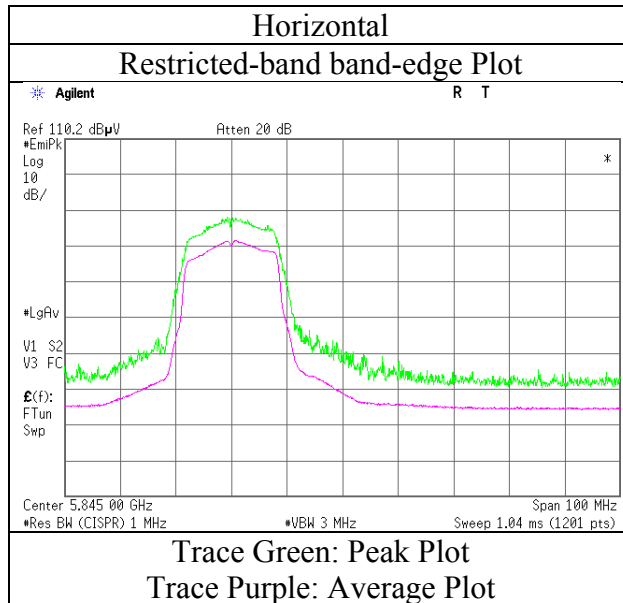

\* Final result of restricted band edge was shown in tabular data.

## Radiated Spurious Emission

Test place : Ise EMC Lab. No.3 Semi Anechoic Chamber  
Report No. : 11500829H  
Date : December 20, 2016      December 21, 2016      December 22, 2016  
Temperature / Humidity : 22deg. C / 37 % RH      25deg. C / 33 % RH      23deg. C / 40 % RH  
Engineer : Tomoki Matsui      Tomoki Matsui      Keisuke Kawamura  
(1 GHz - 10 GHz)      (10 GHz - 26.5 GHz)      (26.5 GHz - 40 GHz)  
Mode : Tx 11ac-20 5745 MHz

Polarity	Frequency [MHz]	Detector	Reading [dBuV]	Ant.Fac. [dB/m]	Loss [dB]	Gain [dB]	Duty Factor [dB]	Result [dBuV/m]	Limit [dBuV/m]	Margin [dB]	Remark
Hori	1050.000	PK	58.2	23.7	5.2	35.2	-	51.9	73.9	22.0	
Hori	1150.000	PK	58.9	24.1	5.3	34.9	-	53.4	73.9	20.5	
Hori	1250.000	PK	53.4	24.4	5.4	34.6	-	48.6	73.9	25.3	
Hori	3830.000	PK	46.4	28.9	6.9	32.0	-	50.2	73.9	23.7	
Hori	5650.000	PK	41.2	31.3	7.7	31.8	-	48.4	68.2	19.8	
Hori	5700.000	PK	40.8	31.4	7.7	31.8	-	48.1	105.2	57.1	
Hori	5715.000	PK	49.1	31.4	7.7	31.8	-	56.4	109.4	53.0	
Hori	5720.000	PK	52.0	31.4	7.7	31.8	-	59.3	110.8	51.5	
Hori	5725.000	PK	54.3	31.4	7.7	31.8	-	61.6	122.2	60.6	
Hori	11490.000	PK	41.7	39.1	-1.6	33.4	-	45.8	73.9	28.1	Floor noise
Hori	17235.000	PK	42.9	42.2	0.2	32.7	-	52.6	73.9	21.3	Floor noise
Hori	22980.000	PK	43.4	39.7	-0.5	32.3	-	50.3	73.9	23.6	Floor noise
Hori	1050.000	AV	56.7	23.7	5.2	35.2	-	50.4	53.9	3.5	
Hori	1150.000	AV	57.4	24.1	5.3	34.9	-	51.9	53.9	2.0	
Hori	1250.000	AV	50.8	24.4	5.4	34.6	-	46.0	53.9	7.9	
Hori	3830.000	AV	39.2	28.9	6.9	32.0	2.2	45.2	53.9	8.7	
Hori	11490.000	AV	32.6	39.1	-1.6	33.4	-	36.7	53.9	17.2	Floor noise
Hori	17235.000	AV	33.8	42.2	0.2	32.7	-	43.5	53.9	10.4	Floor noise
Hori	22980.000	AV	34.7	39.7	-0.5	32.3	-	41.6	53.9	12.3	Floor noise
Vert	1050.000	PK	56.7	23.7	5.2	35.2	-	50.4	73.9	23.5	
Vert	1150.000	PK	56.6	24.1	5.3	34.9	-	51.1	73.9	22.8	
Vert	1250.000	PK	53.4	24.4	5.4	34.6	-	48.6	73.9	25.3	
Vert	3830.000	PK	44.6	28.9	6.9	32.0	-	48.4	73.9	25.5	
Vert	5650.000	PK	40.0	31.3	7.7	31.8	-	47.2	68.2	21.0	
Vert	5700.000	PK	40.6	31.4	7.7	31.8	-	47.9	105.2	57.3	
Vert	5715.000	PK	48.1	31.4	7.7	31.8	-	55.4	109.4	54.0	
Vert	5720.000	PK	50.3	31.4	7.7	31.8	-	57.6	110.8	53.2	
Vert	5725.000	PK	55.2	31.4	7.7	31.8	-	62.5	122.2	59.7	
Vert	11490.000	PK	41.7	39.1	-1.6	33.4	-	45.8	73.9	28.1	Floor noise
Vert	17235.000	PK	42.9	42.2	0.2	32.7	-	52.6	73.9	21.3	Floor noise
Vert	22980.000	PK	43.4	39.7	-0.5	32.3	-	50.3	73.9	23.6	Floor noise
Vert	1050.000	AV	55.0	23.7	5.2	35.2	-	48.7	53.9	5.2	
Vert	1150.000	AV	55.6	24.1	5.3	34.9	-	50.1	53.9	3.8	
Vert	1250.000	AV	51.1	24.4	5.4	34.6	-	46.3	53.9	7.6	
Vert	3830.000	AV	37.7	28.9	6.9	32.0	2.2	43.7	53.9	10.2	
Vert	11490.000	AV	32.6	39.1	-1.6	33.4	-	36.7	53.9	17.2	Floor noise
Vert	17235.000	AV	33.8	42.2	0.2	32.7	-	43.5	53.9	10.4	Floor noise
Vert	22980.000	AV	34.7	39.7	-0.5	32.3	-	41.6	53.9	12.3	Floor noise

Result = Reading + Ant Factor + Loss (Cable+Attenuator+Filter+Distance factor(above 1 GHz)) - Gain(Amplifier) + Duty factor

\*Other frequency noises omitted in this report were not seen or had enough margin (more than 20 dB).

Distance factor:      1 GHz - 10 GHz      20log (4.45 m / 3.0 m) = 3.43 dB  
                                 10 GHz - 40 GHz      20log (1.0 m / 3.0 m) = -9.5 dB

**UL Japan, Inc.**

**Ise EMC Lab.**

4383-326 Asama-cho, Ise-shi, Mie-ken 516-0021 JAPAN

Telephone : +81 596 24 8999

Facsimile : +81 596 24 8124

## Radiated Spurious Emission

Test place	Ise EMC Lab. No.3 Semi Anechoic Chamber
Report No.	11500829H
Date	December 20, 2016
Temperature / Humidity	22deg. C / 37 % RH
Engineer	Tomoki Matsui
Mode	Tx 11ac-20 5745 MHz

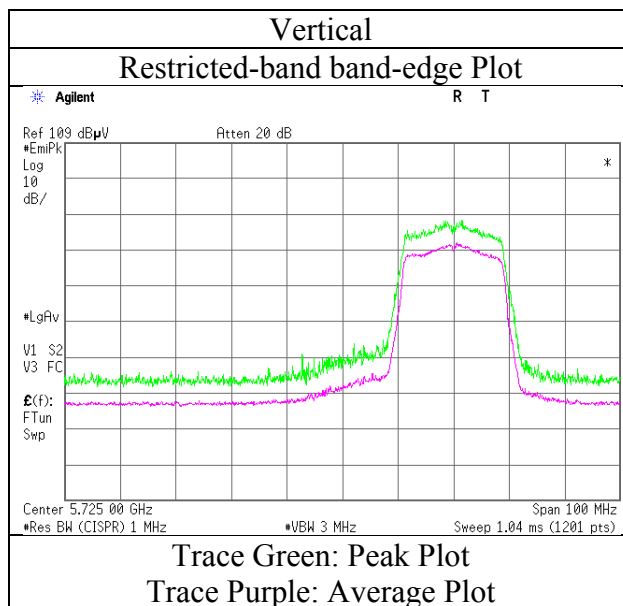
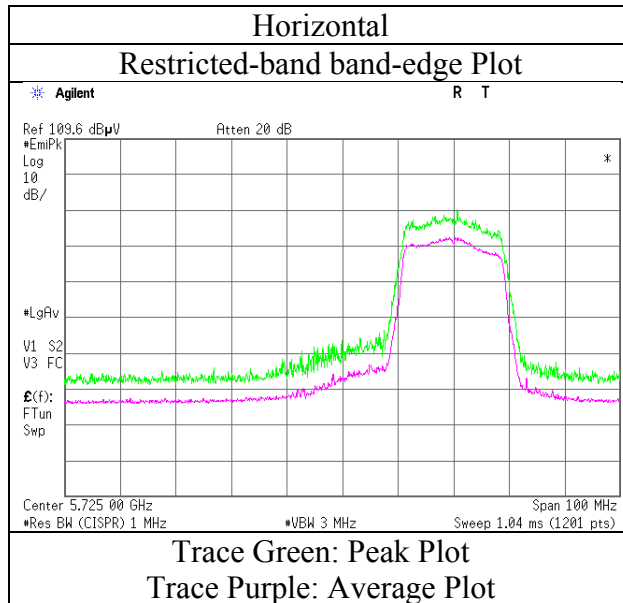

\* Final result of restricted band edge was shown in tabular data.

## Radiated Spurious Emission

Test place	Ise EMC Lab. No.3 Semi Anechoic Chamber		
Report No.	11500829H		
Date	December 20, 2016	December 21, 2016	December 22, 2016
Temperature / Humidity	22deg. C / 37 % RH	25deg. C / 33 % RH	23deg. C / 40 % RH
Engineer	Tomoki Matsui	Tomoki Matsui	Keisuke Kawamura
	(1 GHz - 10 GHz)	(10 GHz - 26.5 GHz)	(26.5 GHz - 40 GHz)
Mode	Tx 11ac-20 5785 MHz		

Polarity	Frequency [MHz]	Detector	Reading [dBuV]	Ant.Fac. [dB/m]	Loss [dB]	Gain [dB]	Duty Factor [dB]	Result [dBuV/m]	Limit [dBuV/m]	Margin [dB]	Remark
Hori	1050.000	PK	59.1	23.7	5.2	35.2	-	52.8	73.9	21.1	
Hori	1150.000	PK	58.5	24.1	5.3	34.9	-	53.0	73.9	20.9	
Hori	1250.000	PK	53.1	24.4	5.4	34.6	-	48.3	73.9	25.6	
Hori	3856.646	PK	46.0	29.0	6.9	32.0	-	49.9	73.9	24.0	
Hori	11570.000	PK	40.4	39.1	-1.6	33.4	-	44.5	73.9	29.4	Floor noise
Hori	17355.000	PK	41.6	42.8	0.3	32.7	-	52.0	73.9	21.9	Floor noise
Hori	23140.000	PK	43.9	39.6	-0.5	32.3	-	50.7	73.9	23.2	Floor noise
Hori	1050.000	AV	57.2	23.7	5.2	35.2	-	50.9	53.9	3.0	
Hori	1150.000	AV	57.1	24.1	5.3	34.9	-	51.6	53.9	2.3	
Hori	1250.000	AV	50.5	24.4	5.4	34.6	-	45.7	53.9	8.2	
Hori	3856.646	AV	39.6	29.0	6.9	32.0	2.2	45.7	53.9	8.2	
Hori	11570.000	AV	32.8	39.1	-1.6	33.4	-	36.9	53.9	17.0	Floor noise
Hori	17355.000	AV	32.8	42.8	0.3	32.7	-	43.2	53.9	10.7	Floor noise
Hori	23140.000	AV	35.4	39.6	-0.5	32.3	-	42.2	53.9	11.7	Floor noise
Vert	1050.000	PK	56.5	23.7	5.2	35.2	-	50.2	73.9	23.7	
Vert	1150.000	PK	57.8	24.1	5.3	34.9	-	52.3	73.9	21.6	
Vert	1250.000	PK	54.3	24.4	5.4	34.6	-	49.5	73.9	24.4	
Vert	3856.646	PK	45.3	29.0	6.9	32.0	-	49.2	73.9	24.7	
Vert	11570.000	PK	40.4	39.1	-1.6	33.4	-	44.5	73.9	29.4	Floor noise
Vert	17355.000	PK	41.6	42.8	0.3	32.7	-	52.0	73.9	21.9	Floor noise
Vert	23140.000	PK	43.9	39.6	-0.5	32.3	-	50.7	73.9	23.2	Floor noise
Vert	1050.000	AV	55.2	23.7	5.2	35.2	-	48.9	53.9	5.0	
Vert	1150.000	AV	56.0	24.1	5.3	34.9	-	50.5	53.9	3.4	
Vert	1250.000	AV	51.2	24.4	5.4	34.6	-	46.4	53.9	7.5	
Vert	3856.646	AV	37.8	29.0	6.9	32.0	2.2	43.9	53.9	10.0	
Vert	11570.000	AV	32.8	39.1	-1.6	33.4	-	36.9	53.9	17.0	Floor noise
Vert	17355.000	AV	32.8	42.8	0.3	32.7	-	43.2	53.9	10.7	Floor noise
Vert	23140.000	AV	35.4	39.6	-0.5	32.3	-	42.2	53.9	11.7	Floor noise

Result = Reading + Ant Factor + Loss (Cable+Attenuator+Filter+Distance factor(above 1 GHz)) - Gain(Amplifier) + Duty factor

\*Other frequency noises omitted in this report were not seen or had enough margin (more than 20 dB).

Distance factor:    1 GHz - 10 GHz     $20\log(4.45\text{ m} / 3.0\text{ m}) = 3.43\text{ dB}$   
                          10 GHz - 40 GHz     $20\log(1.0\text{ m} / 3.0\text{ m}) = -9.5\text{ dB}$

## Radiated Spurious Emission

Test place : Ise EMC Lab. No.3 Semi Anechoic Chamber  
Report No. : 11500829H  
Date : December 20, 2016      December 21, 2016      December 22, 2016  
Temperature / Humidity : 22deg. C / 37 % RH      25deg. C / 33 % RH      23deg. C / 40 % RH  
Engineer : Tomoki Matsui      Tomoki Matsui      Keisuke Kawamura  
(1 GHz - 10 GHz)      (10 GHz - 26.5 GHz)      (26.5 GHz - 40 GHz)  
Mode : Tx 11ac-20 5825 MHz

Polarity	Frequency [MHz]	Detector	Reading [dBuV]	Ant.Fac. [dB/m]	Loss [dB]	Gain [dB]	Duty Factor [dB]	Result [dBuV/m]	Limit [dBuV/m]	Margin [dB]	Remark
Hori	1050.000	PK	59.3	23.7	5.2	35.2	-	53.0	73.9	20.9	
Hori	1150.000	PK	58.5	24.1	5.3	34.9	-	53.0	73.9	20.9	
Hori	1250.000	PK	53.2	24.4	5.4	34.6	-	48.4	73.9	25.5	
Hori	3883.333	PK	46.4	29.0	6.9	32.0	-	50.3	73.9	23.6	
Hori	5850.000	PK	48.9	31.6	7.7	31.8	-	56.4	122.2	65.8	
Hori	5855.000	PK	46.6	31.6	7.7	31.8	-	54.1	110.8	56.7	
Hori	5860.000	PK	44.0	31.6	7.7	31.8	-	51.5	109.4	57.9	
Hori	5875.000	PK	39.7	31.6	7.7	31.8	-	47.2	105.2	58.0	
Hori	5925.000	PK	39.8	31.6	7.7	31.8	-	47.3	68.2	20.9	
Hori	11650.000	PK	42.9	39.0	-1.4	33.4	-	47.1	73.9	26.8	Floor noise
Hori	17475.000	PK	42.5	43.5	0.4	32.7	-	53.7	73.9	20.2	Floor noise
Hori	23300.000	PK	43.3	39.5	-0.5	32.2	-	50.1	73.9	23.8	Floor noise
Hori	1050.000	AV	57.2	23.7	5.2	35.2	-	50.9	53.9	3.0	
Hori	1150.000	AV	57.2	24.1	5.3	34.9	-	51.7	53.9	2.2	
Hori	1250.000	AV	49.9	24.4	5.4	34.6	-	45.1	53.9	8.8	
Hori	3883.333	AV	40.4	29.0	6.9	32.0	2.2	46.5	53.9	7.4	
Hori	11650.000	AV	33.8	39.0	-1.4	33.4	-	38.0	53.9	15.9	Floor noise
Hori	17475.000	AV	33.7	43.5	0.4	32.7	-	44.9	53.9	9.0	Floor noise
Hori	23300.000	AV	35.0	39.5	-0.5	32.2	-	41.8	53.9	12.1	Floor noise
Vert	1050.000	PK	57.1	23.7	5.2	35.2	-	50.8	73.9	23.1	
Vert	1150.000	PK	57.8	24.1	5.3	34.9	-	52.3	73.9	21.6	
Vert	1250.000	PK	53.8	24.4	5.4	34.6	-	49.0	73.9	24.9	
Vert	3883.333	PK	45.3	29.0	6.9	32.0	-	49.2	73.9	24.7	
Vert	5850.000	PK	45.7	31.6	7.7	31.8	-	53.2	122.2	69.0	
Vert	5855.000	PK	44.9	31.6	7.7	31.8	-	52.4	110.8	58.4	
Vert	5860.000	PK	42.3	31.6	7.7	31.8	-	49.8	109.4	59.6	
Vert	5875.000	PK	39.8	31.6	7.7	31.8	-	47.3	105.2	57.9	
Vert	5925.000	PK	39.8	31.6	7.7	31.8	-	47.3	68.2	20.9	
Vert	11650.000	PK	42.9	39.0	-1.4	33.4	-	47.1	73.9	26.8	Floor noise
Vert	17475.000	PK	42.5	43.5	0.4	32.7	-	53.7	73.9	20.2	Floor noise
Vert	23300.000	PK	43.3	39.5	-0.5	32.2	-	50.1	73.9	23.8	Floor noise
Vert	1050.000	AV	55.6	23.7	5.2	35.2	-	49.3	53.9	4.6	
Vert	1150.000	AV	55.9	24.1	5.3	34.9	-	50.4	53.9	3.5	
Vert	1250.000	AV	51.0	24.4	5.4	34.6	-	46.2	53.9	7.7	
Vert	3883.333	AV	39.4	29.0	6.9	32.0	2.2	45.5	53.9	8.4	
Vert	11650.000	AV	33.8	39.0	-1.4	33.4	-	38.0	53.9	15.9	Floor noise
Vert	17475.000	AV	33.7	43.5	0.4	32.7	-	44.9	53.9	9.0	Floor noise
Vert	23300.000	AV	35.0	39.5	-0.5	32.2	-	41.8	53.9	12.1	Floor noise

Result = Reading + Ant Factor + Loss (Cable+Attenuator+Filter+Distance factor(above 1 GHz)) - Gain(Amplifier) + Duty factor

\*Other frequency noises omitted in this report were not seen or had enough margin (more than 20 dB).

Distance factor:      1 GHz - 10 GHz      20log(4.45 m / 3.0 m) = 3.43 dB  
                                 10 GHz - 40 GHz      20log(1.0 m / 3.0 m) = -9.5 dB

## Radiated Spurious Emission

Test place	Ise EMC Lab. No.3 Semi Anechoic Chamber
Report No.	11500829H
Date	December 20, 2016
Temperature / Humidity	22deg. C / 37 % RH
Engineer	Tomoki Matsui
Mode	Tx 11ac-20 5825 MHz

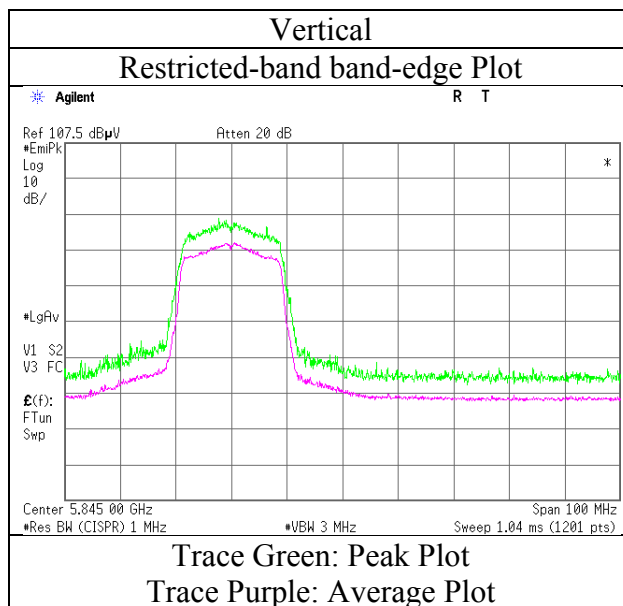
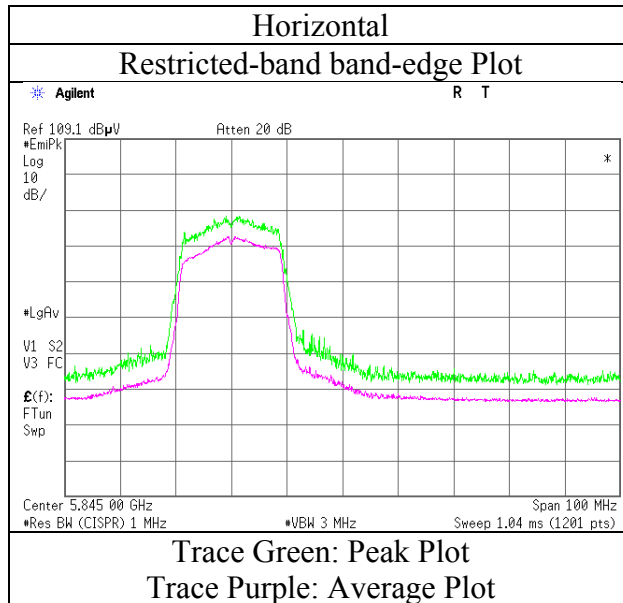

\* Final result of restricted band edge was shown in tabular data.

## Radiated Spurious Emission

Test place : Ise EMC Lab. No.3 Semi Anechoic Chamber  
Report No. : 11500829H  
Date : December 20, 2016      December 21, 2016      December 22, 2016  
Temperature / Humidity : 22deg. C / 37 % RH      25deg. C / 33 % RH      23deg. C / 40 % RH  
Engineer : Tomoki Matsui      Tomoki Matsui      Keisuke Kawamura  
(1 GHz - 10 GHz)      (10 GHz - 26.5 GHz)      (26.5 GHz - 40 GHz)  
Mode : Tx 11ac-40 5755 MHz

Polarity	Frequency [MHz]	Detector	Reading [dBuV]	Ant.Fac. [dB/m]	Loss [dB]	Gain [dB]	Duty Factor [dB]	Result [dBuV/m]	Limit [dBuV/m]	Margin [dB]	Remark
Hori	1050.000	PK	58.1	23.7	5.2	35.2	-	51.8	73.9	22.1	
Hori	1150.000	PK	58.9	24.1	5.3	34.9	-	53.4	73.9	20.5	
Hori	1250.000	PK	53.2	24.4	5.4	34.6	-	48.4	73.9	25.5	
Hori	3836.633	PK	45.7	28.9	6.9	32.0	-	49.5	73.9	24.4	
Hori	5650.000	PK	40.2	31.3	7.7	31.8	-	47.4	68.2	20.8	
Hori	5700.000	PK	47.1	31.4	7.7	31.8	-	54.4	105.2	50.8	
Hori	5715.000	PK	56.7	31.4	7.7	31.8	-	64.0	109.4	45.4	
Hori	5720.000	PK	57.7	31.4	7.7	31.8	-	65.0	110.8	45.8	
Hori	5725.000	PK	57.3	31.4	7.7	31.8	-	64.6	122.2	57.6	
Hori	11510.000	PK	42.4	39.1	-1.6	33.4	-	46.5	73.9	27.4	Floor noise
Hori	17265.000	PK	41.7	42.3	0.3	32.7	-	51.6	73.9	22.3	Floor noise
Hori	23020.000	PK	45.1	39.7	-0.5	32.3	-	52.0	73.9	21.9	Floor noise
Hori	1050.000	AV	56.7	23.7	5.2	35.2	-	50.4	53.9	3.5	
Hori	1150.000	AV	57.4	24.1	5.3	34.9	-	51.9	53.9	2.0	
Hori	1250.000	AV	50.8	24.4	5.4	34.6	-	46.0	53.9	7.9	
Hori	3836.633	AV	40.7	28.9	6.9	32.0	1.2	45.7	53.9	8.2	
Hori	11510.000	AV	33.3	39.1	-1.6	33.4	-	37.4	53.9	16.5	Floor noise
Hori	17265.000	AV	33.4	42.3	0.3	32.7	-	43.3	53.9	10.6	Floor noise
Hori	23020.000	AV	35.4	39.7	-0.5	32.3	-	42.3	53.9	11.6	Floor noise
Vert	1050.000	PK	56.8	23.7	5.2	35.2	-	50.5	73.9	23.4	
Vert	1150.000	PK	57.2	24.1	5.3	34.9	-	51.7	73.9	22.2	
Vert	1250.000	PK	53.7	24.4	5.4	34.6	-	48.9	73.9	25.0	
Vert	3836.633	PK	45.8	28.9	6.9	32.0	-	49.6	73.9	24.3	
Vert	5650.000	PK	40.7	31.3	7.7	31.8	-	47.9	68.2	20.3	
Vert	5700.000	PK	44.7	31.4	7.7	31.8	-	52.0	105.2	53.2	
Vert	5715.000	PK	53.9	31.4	7.7	31.8	-	61.2	109.4	48.2	
Vert	5720.000	PK	55.6	31.4	7.7	31.8	-	62.9	110.8	47.9	
Vert	5725.000	PK	55.1	31.4	7.7	31.8	-	62.4	122.2	59.8	
Vert	11510.000	PK	42.4	39.1	-1.6	33.4	-	46.5	73.9	27.4	Floor noise
Vert	17265.000	PK	41.7	42.3	0.3	32.7	-	51.6	73.9	22.3	Floor noise
Vert	23020.000	PK	45.1	39.7	-0.5	32.3	-	52.0	73.9	21.9	Floor noise
Vert	1050.000	AV	55.0	23.7	5.2	35.2	-	48.7	53.9	5.2	
Vert	1150.000	AV	55.9	24.1	5.3	34.9	-	50.4	53.9	3.5	
Vert	1250.000	AV	51.4	24.4	5.4	34.6	-	46.6	53.9	7.3	
Vert	3836.633	AV	39.4	28.9	6.9	32.0	1.2	44.4	53.9	9.5	
Vert	11510.000	AV	33.3	39.1	-1.6	33.4	-	37.4	53.9	16.5	Floor noise
Vert	17265.000	AV	33.4	42.3	0.3	32.7	-	43.3	53.9	10.6	Floor noise
Vert	23020.000	AV	35.4	39.7	-0.5	32.3	-	42.3	53.9	11.6	Floor noise

Result = Reading + Ant Factor + Loss (Cable+Attenuator+Filter+Distance factor(above 1 GHz)) - Gain(Amplifier) + Duty factor

\*Other frequency noises omitted in this report were not seen or had enough margin (more than 20 dB).

Distance factor:      1 GHz - 10 GHz      20log (4.45 m / 3.0 m) = 3.43 dB  
                                 10 GHz - 40 GHz      20log (1.0 m / 3.0 m) = -9.5 dB

## Radiated Spurious Emission

Test place	Ise EMC Lab. No.3 Semi Anechoic Chamber
Report No.	11500829H
Date	December 20, 2016
Temperature / Humidity	22deg. C / 37 % RH
Engineer	Tomoki Matsui
Mode	Tx 11ac-40 5755 MHz

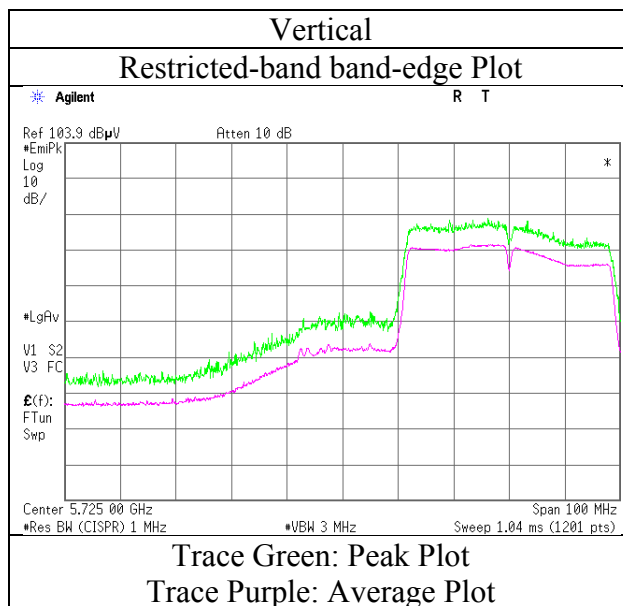
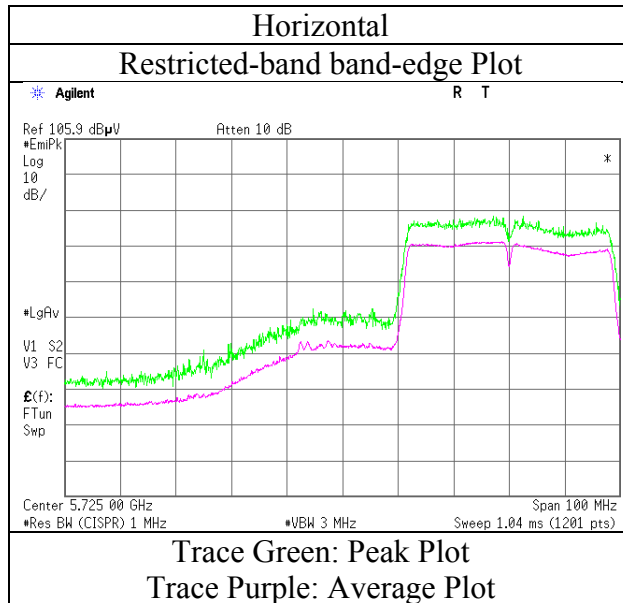

\* Final result of restricted band edge was shown in tabular data.

## Radiated Spurious Emission

Test place : Ise EMC Lab. No.3 Semi Anechoic Chamber  
Report No. : 11500829H  
Date : December 20, 2016      December 21, 2016      December 22, 2016  
Temperature / Humidity : 22deg. C / 37 % RH      25deg. C / 33 % RH      23deg. C / 40 % RH  
Engineer : Tomoki Matsui      Tomoki Matsui      Keisuke Kawamura  
(1 GHz - 10 GHz)      (10 GHz - 26.5 GHz)      (26.5 GHz - 40 GHz)  
Mode : Tx 11ac-40 5795 MHz

Polarity	Frequency [MHz]	Detector	Reading [dBuV]	Ant.Fac. [dB/m]	Loss [dB]	Gain [dB]	Duty Factor [dB]	Result [dBuV/m]	Limit [dBuV/m]	Margin [dB]	Remark
Hori	1050.000	PK	59.1	23.7	5.2	35.2	-	52.8	73.9	21.1	
Hori	1150.000	PK	58.3	24.1	5.3	34.9	-	52.8	73.9	21.1	
Hori	1250.000	PK	53.2	24.4	5.4	34.6	-	48.4	73.9	25.5	
Hori	3863.275	PK	45.5	29.0	6.9	32.0	-	49.4	73.9	24.5	
Hori	5850.000	PK	43.2	31.6	7.7	31.8	-	50.7	122.2	71.5	
Hori	5855.000	PK	42.5	31.6	7.7	31.8	-	50.0	110.8	60.8	
Hori	5860.000	PK	41.8	31.6	7.7	31.8	-	49.3	109.4	60.1	
Hori	5875.000	PK	40.1	31.6	7.7	31.8	-	47.6	105.2	57.6	
Hori	5925.000	PK	39.8	31.6	7.7	31.8	-	47.3	68.2	20.9	
Hori	11590.000	PK	43.3	39.1	-1.6	33.4	-	47.4	73.9	26.5	Floor noise
Hori	17385.000	PK	42.1	43.0	0.3	32.7	-	52.7	73.9	21.2	Floor noise
Hori	23180.000	PK	44.0	39.6	-0.5	32.3	-	50.8	73.9	23.1	Floor noise
Hori	1050.000	AV	57.1	23.7	5.2	35.2	-	50.8	53.9	3.1	
Hori	1150.000	AV	57.0	24.1	5.3	34.9	-	51.5	53.9	2.4	
Hori	1250.000	AV	49.9	24.4	5.4	34.6	-	45.1	53.9	8.8	
Hori	3863.275	AV	40.0	29.0	6.9	32.0	1.2	45.1	53.9	8.8	
Hori	11590.000	AV	33.3	39.1	-1.6	33.4	-	37.4	53.9	16.5	Floor noise
Hori	17385.000	AV	33.3	43.0	0.3	32.7	-	43.9	53.9	10.0	Floor noise
Hori	23180.000	AV	35.3	39.6	-0.5	32.3	-	42.1	53.9	11.8	Floor noise
Vert	1050.000	PK	57.1	23.7	5.2	35.2	-	50.8	73.9	23.1	
Vert	1150.000	PK	57.3	24.1	5.3	34.9	-	51.8	73.9	22.1	
Vert	1250.000	PK	53.7	24.4	5.4	34.6	-	48.9	73.9	25.0	
Vert	3863.275	PK	44.9	29.0	6.9	32.0	-	48.8	73.9	25.1	
Vert	5850.000	PK	41.1	31.6	7.7	31.8	-	48.6	122.2	73.6	
Vert	5855.000	PK	40.7	31.6	7.7	31.8	-	48.2	110.8	62.6	
Vert	5860.000	PK	41.1	31.6	7.7	31.8	-	48.6	109.4	60.8	
Vert	5875.000	PK	40.1	31.6	7.7	31.8	-	47.6	105.2	57.6	
Vert	5925.000	PK	39.4	31.6	7.7	31.8	-	46.9	68.2	21.3	
Vert	11590.000	PK	43.3	39.1	-1.6	33.4	-	47.4	73.9	26.5	Floor noise
Vert	17385.000	PK	42.1	43.0	0.3	32.7	-	52.7	73.9	21.2	Floor noise
Vert	23180.000	PK	44.0	39.6	-0.5	32.3	-	50.8	73.9	23.1	Floor noise
Vert	1050.000	AV	55.6	23.7	5.2	35.2	-	49.3	53.9	4.6	
Vert	1150.000	AV	55.4	24.1	5.3	34.9	-	49.9	53.9	4.0	
Vert	1250.000	AV	51.0	24.4	5.4	34.6	-	46.2	53.9	7.7	
Vert	3863.275	AV	38.8	29.0	6.9	32.0	1.2	43.9	53.9	10.0	
Vert	11590.000	AV	33.3	39.1	-1.6	33.4	-	37.4	53.9	16.5	Floor noise
Vert	17385.000	AV	33.3	43.0	0.3	32.7	-	43.9	53.9	10.0	Floor noise
Vert	23180.000	AV	35.3	39.6	-0.5	32.3	-	42.1	53.9	11.8	Floor noise

Result = Reading + Ant Factor + Loss (Cable+Attenuator+Filter+Distance factor(above 1 GHz)) - Gain(Amplifier) + Duty factor

\*Other frequency noise omitted in this report were not seen or had enough margin (more than 20 dB).

Distance factor:      1 GHz - 10 GHz      20log (4.45 m / 3.0 m) = 3.43 dB  
                                 10 GHz - 40 GHz      20log (1.0 m / 3.0 m) = -9.5 dB

## Radiated Spurious Emission

Test place	Ise EMC Lab. No.3 Semi Anechoic Chamber
Report No.	11500829H
Date	December 20, 2016
Temperature / Humidity	22deg. C / 37 % RH
Engineer	Tomoki Matsui
Mode	Tx 11ac-40 5795 MHz

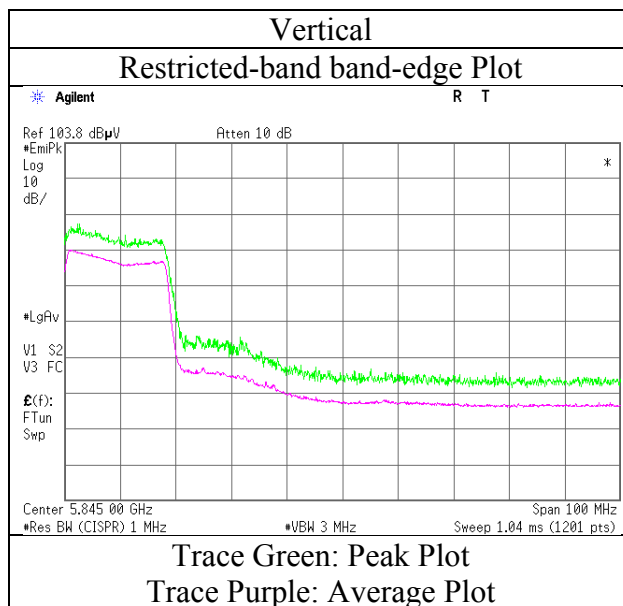
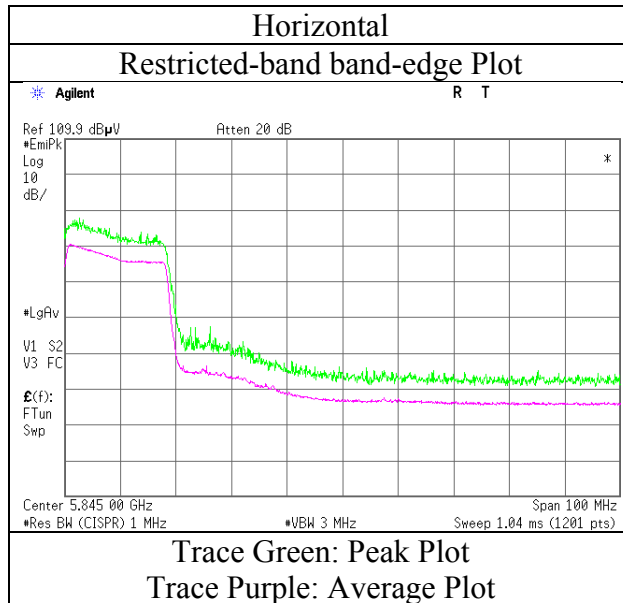

\* Final result of restricted band edge was shown in tabular data.

## Radiated Spurious Emission

Test place	Ise EMC Lab. No.3 Semi Anechoic Chamber		
Report No.	11500829H		
Date	December 20, 2016	December 21, 2016	December 22, 2016
Temperature / Humidity	22deg. C / 37 % RH	25deg. C / 33 % RH	23deg. C / 40 % RH
Engineer	Tomoki Matsui	Tomoki Matsui	Keisuke Kawamura
	(1 GHz - 10 GHz)	(10 GHz - 26.5 GHz)	(26.5 GHz - 40 GHz)
Mode	Tx 11ac-80 5775 MHz		

Polarity	Frequency [MHz]	Detector	Reading [dBuV]	Ant.Fac. [dB/m]	Loss [dB]	Gain [dB]	Duty Factor [dB]	Result [dBuV/m]	Limit [dBuV/m]	Margin [dB]	Remark
Hori	1050.000	PK	58.9	23.7	5.2	35.2	-	52.6	73.9	21.3	
Hori	1150.000	PK	57.8	24.1	5.3	34.9	-	52.3	73.9	21.6	
Hori	1250.000	PK	52.1	24.4	5.4	34.6	-	47.3	73.9	26.6	
Hori	3849.985	PK	46.5	29.0	6.9	32.0	-	50.4	73.9	23.5	
Hori	5650.000	PK	41.2	31.3	7.7	31.8	-	48.4	68.2	19.8	
Hori	5700.000	PK	45.4	31.4	7.7	31.8	-	52.7	105.2	52.5	
Hori	5715.000	PK	47.6	31.4	7.7	31.8	-	54.9	109.4	54.5	
Hori	5720.000	PK	50.5	31.4	7.7	31.8	-	57.8	110.8	53.0	
Hori	5725.000	PK	49.5	31.4	7.7	31.8	-	56.8	122.2	65.4	
Hori	5850.000	PK	47.7	31.6	7.7	31.8	-	55.2	122.2	67.0	
Hori	5855.000	PK	45.6	31.6	7.7	31.8	-	53.1	110.8	57.7	
Hori	5860.000	PK	45.5	31.6	7.7	31.8	-	53.0	109.4	56.4	
Hori	5875.000	PK	40.5	31.6	7.7	31.8	-	48.0	105.2	57.2	
Hori	5925.000	PK	40.4	31.6	7.7	31.8	-	47.9	68.2	20.3	
Hori	11550.000	PK	41.1	39.1	-1.6	33.4	-	45.2	73.9	28.7	Floor noise
Hori	17325.000	PK	41.8	42.7	0.3	32.7	-	52.1	73.9	21.8	Floor noise
Hori	23100.000	PK	43.5	39.7	-0.5	32.3	-	50.4	73.9	23.5	Floor noise
Hori	1050.000	AV	57.0	23.7	5.2	35.2	-	50.7	53.9	3.2	
Hori	1150.000	AV	56.7	24.1	5.3	34.9	-	51.2	53.9	2.7	
Hori	1250.000	AV	49.0	24.4	5.4	34.6	-	44.2	53.9	9.7	
Hori	3849.985	AV	39.6	29.0	6.9	32.0	3.9	47.4	53.9	6.5	
Hori	11550.000	AV	32.0	39.1	-1.6	33.4	-	36.1	53.9	17.8	Floor noise
Hori	17325.000	AV	33.0	42.7	0.3	32.7	-	43.3	53.9	10.6	Floor noise
Hori	23100.000	AV	35.1	39.7	-0.5	32.3	-	42.0	53.9	11.9	Floor noise
Vert	1050.000	PK	57.2	23.7	5.2	35.2	-	50.9	73.9	23.0	
Vert	1150.000	PK	57.1	24.1	5.3	34.9	-	51.6	73.9	22.3	
Vert	1250.000	PK	53.9	24.4	5.4	34.6	-	49.1	73.9	24.8	
Vert	3849.985	PK	45.9	29.0	6.9	32.0	-	49.8	73.9	24.1	
Vert	5650.000	PK	41.9	31.3	7.7	31.8	-	49.1	68.2	19.1	
Vert	5700.000	PK	44.8	31.4	7.7	31.8	-	52.1	105.2	53.1	
Vert	5715.000	PK	47.6	31.4	7.7	31.8	-	54.9	109.4	54.5	
Vert	5720.000	PK	49.7	31.4	7.7	31.8	-	57.0	110.8	53.8	
Vert	5725.000	PK	49.8	31.4	7.7	31.8	-	57.1	122.2	65.1	
Vert	5850.000	PK	47.5	31.6	7.7	31.8	-	55.0	122.2	67.2	
Vert	5855.000	PK	45.3	31.6	7.7	31.8	-	52.8	110.8	58.0	
Vert	5860.000	PK	45.3	31.6	7.7	31.8	-	52.8	109.4	56.6	
Vert	5875.000	PK	40.9	31.6	7.7	31.8	-	48.4	105.2	56.8	
Vert	5925.000	PK	39.8	31.6	7.7	31.8	-	47.3	68.2	20.9	
Vert	11550.000	PK	41.1	39.1	-1.6	33.4	-	45.2	73.9	28.7	Floor noise
Vert	17325.000	PK	41.8	42.7	0.3	32.7	-	52.1	73.9	21.8	Floor noise
Vert	23100.000	PK	43.5	39.7	-0.5	32.3	-	50.4	73.9	23.5	Floor noise
Vert	1050.000	AV	55.6	23.7	5.2	35.2	-	49.3	53.9	4.6	
Vert	1150.000	AV	55.1	24.1	5.3	34.9	-	49.6	53.9	4.3	
Vert	1250.000	AV	51.1	24.4	5.4	34.6	-	46.3	53.9	7.6	
Vert	3849.985	AV	39.1	29.0	6.9	32.0	3.9	46.9	53.9	7.0	
Vert	11550.000	AV	32.0	39.1	-1.6	33.4	-	36.1	53.9	17.8	Floor noise
Vert	17325.000	AV	33.0	42.7	0.3	32.7	-	43.3	53.9	10.6	Floor noise
Vert	23100.000	AV	35.1	39.7	-0.5	32.3	-	42.0	53.9	11.9	Floor noise

Result = Reading + Ant Factor + Loss (Cable+Attenuator+Filter+Distance factor(above 1 GHz)) - Gain(Amplifier) + Duty factor

\*Other frequency noises omitted in this report were not seen or had enough margin (more than 20 dB).

Distance factor:      1 GHz - 10 GHz      20log(4.45 m / 3.0 m) = 3.43 dB  
                                 10 GHz - 40 GHz      20log(1.0 m / 3.0 m) = -9.5 dB

**UL Japan, Inc.**

**Ise EMC Lab.**

4383-326 Asama-cho, Ise-shi, Mie-ken 516-0021 JAPAN

Telephone : +81 596 24 8999

Facsimile : +81 596 24 8124

## Radiated Spurious Emission

Test place	Ise EMC Lab. No.3 Semi Anechoic Chamber
Report No.	11500829H
Date	December 20, 2016
Temperature / Humidity	22deg. C / 37 % RH
Engineer	Tomoki Matsui
Mode	Tx 11ac-80 5775 MHz

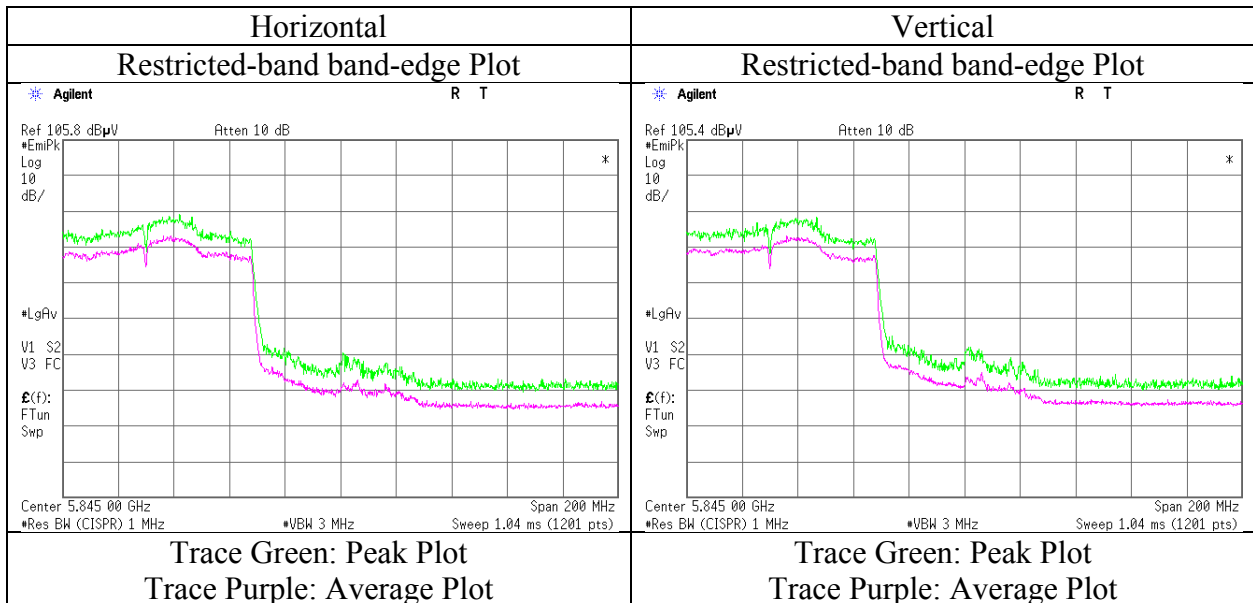
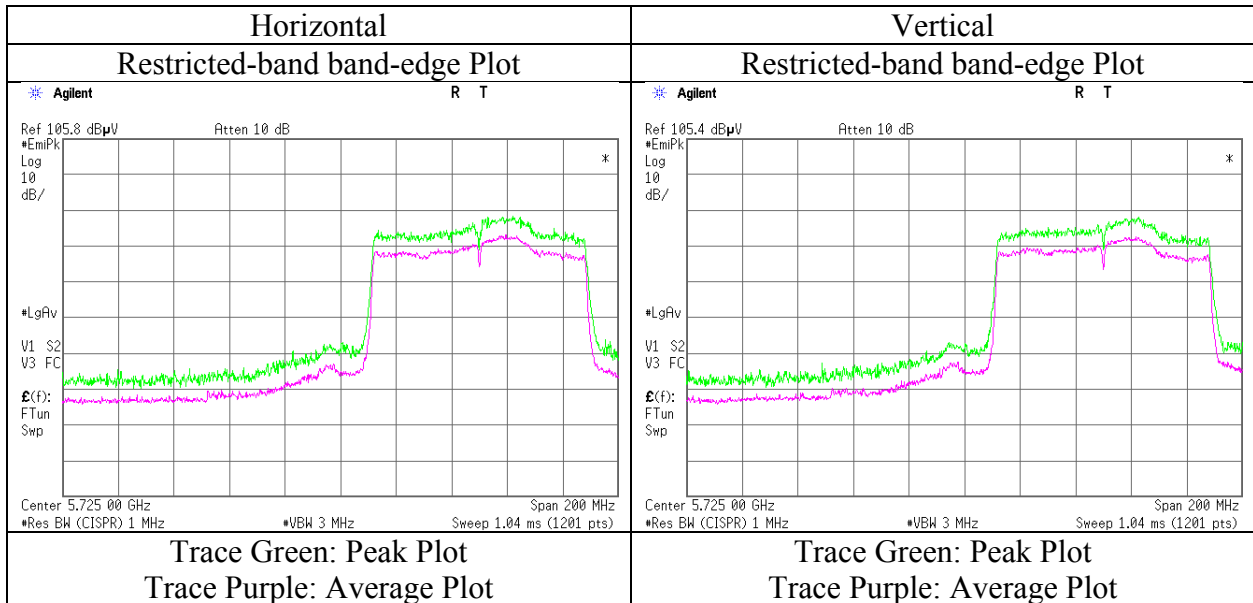

\* Final result of restricted band edge was shown in tabular data.

**UL Japan, Inc.**

**Ise EMC Lab.**

4383-326 Asama-cho, Ise-shi, Mie-ken 516-0021 JAPAN

Telephone : +81 596 24 8999

Facsimile : +81 596 24 8124

**Radiated Spurious Emission**  
**(Plot data, Worst case)**

Test place	Ise EMC Lab. No.3 Semi Anechoic Chamber			
Report No.	11500829H			
Date	December 20, 2016	December 21, 2016	December 22, 2016	December 22, 2016
Temperature / Humidity	22deg. C / 37 % RH	25deg. C / 33 % RH	23deg. C / 40 % RH	23deg. C / 45 % RH
Engineer	Tomoki Matsui (1 GHz - 10 GHz)	Tomoki Matsui (10 GHz - 26.5 GHz)	Keisuke Kawamura (26.5 GHz - 40 GHz)	Tomoki Matsui (Below 1 GHz)
Mode	Tx 11a 5825 MHz			

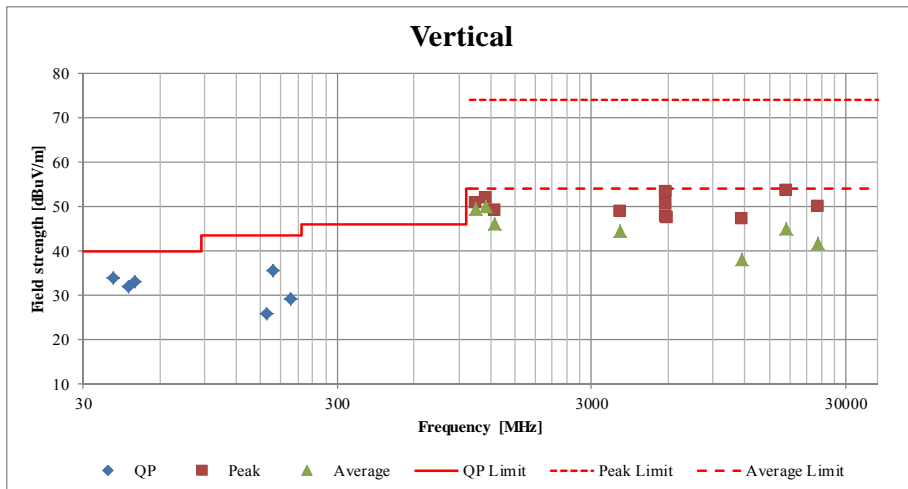
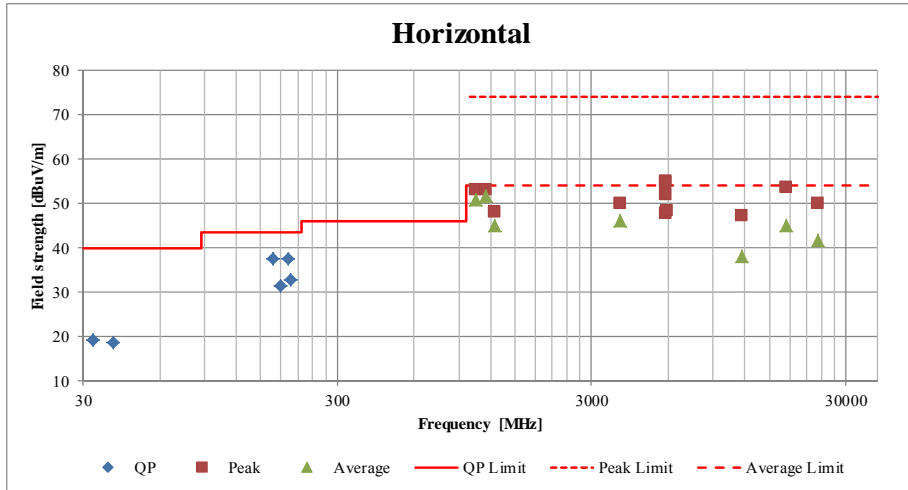

\*These plots data contains sufficient number to show the trend of characteristic features for EUT.

## Conducted Spurious Emission

Test place	Ise EMC Lab. No.6 Measurement Room
Report No.	11500829H
Date	December 15, 2016
Temperature / Humidity	23deg. C / 31 % RH
Engineer	Yutaka Yoshida
Mode	Tx 11a 6Mbps, 5825 MHz

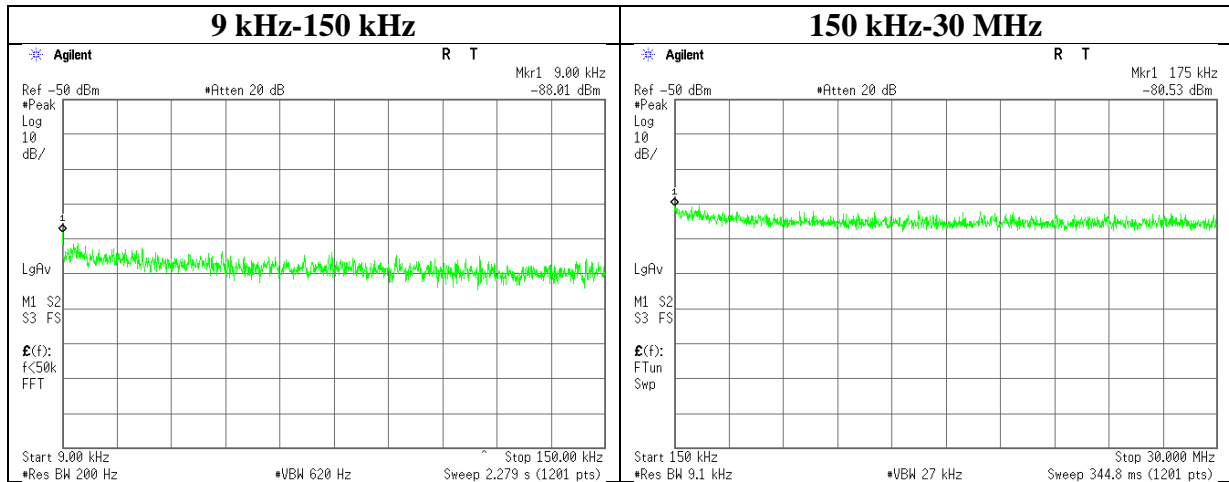

Frequency [kHz]	Reading [dBm]	Cable Loss [dB]	Attenuator [dB]	Antenna Gain* [dBi]	N (Number of Output)	EIRP [dBm]	Distance [m]	Ground bounce [dB]	E (field strength) [dBuV/m]	Limit [dBuV/m]	Margin [dB]	Remark
9.00	-88.0	0.01	9.8	2.0	1	-76.2	300	6.0	-14.9	48.5	63.4	
175.00	-80.5	0.01	9.8	2.0	1	-68.7	300	6.0	-7.4	22.7	30.1	

$E \text{ [dBuV/m]} = \text{EIRP [dBm]} - 20 \log(\text{Distance [m]}) + \text{Ground bounce [dB]} + 104.8 \text{ [dBuV/m]}$

$\text{EIRP [dBm]} = \text{Reading [dBm]} + \text{Cable loss [dB]} + \text{Attenuator Loss [dB]} + \text{Antenna gain [dBi]} + 10 * \log(N)$

N: Number of output

\*2.0 dBi was applied to the test result based on KDB 558074 since antenna gain was less than 2.0 dBi.

**UL Japan, Inc.**

**Ise EMC Lab.**

4383-326 Asama-cho, Ise-shi, Mie-ken 516-0021 JAPAN

Telephone : +81 596 24 8999

Facsimile : +81 596 24 8124

## **APPENDIX 2: Test instruments**

### **Test equipment**

<b>Control No.</b>	<b>Instrument</b>	<b>Manufacturer</b>	<b>Model No</b>	<b>Serial No</b>	<b>Test Item</b>	<b>Calibration Date * Interval(month)</b>
MOS-14	Thermo-Hygrometer	Custom	CTH-201	1401	AT	2016/01/21 * 12
MSA-10	Spectrum Analyzer	Agilent	E4448A	MY46180655	AT	2016/08/17 * 12
MCC-172	Microwave Cable	Junkosha	MWX221	1409S495	AT	2016/03/11 * 12
MAT-58	Attenuator(10dB)	Suhner	6810.19.A	-	AT	2016/12/15 * 12
MMM-10	DIGITAL HiTESTER	Hioki	3805	051201148	AT	2016/01/18 * 12
MPM-16	Power Meter	Agilent	8990B	MY51000271	AT	2016/04/07 * 12
MPSE-23	Power sensor	Agilent	N1923A	MY54070004	AT	2016/04/07 * 12
MCC-64	Coaxial Cable	UL Japan	-	-	AT	2016/03/10 * 12
MAT-10	Attenuator(10dB)	Weinschel Corp	2	BL1173	AT	2016/11/28 * 12
MAEC-03	Semi Anechoic Chamber(NSA)	TDK	Semi Anechoic Chamber 3m	DA-10005	RE	2016/10/20 * 12
MOS-13	Thermo-Hygrometer	Custom	CTH-180	1301	RE	2016/01/21 * 12
MJM-16	Measure	KOMELON	KMC-36	-	RE	-
COTS-MEMI	EMI measurement program	TSJ	TEPTO-DV	-	RE	-
MSA-16	Spectrum Analyzer	Agilent	E4440A	MY46186390	RE	2016/02/08 * 12
MHA-20	Horn Antenna 1-18GHz	Schwarzbeck	BBHA9120D	258	RE	2016/05/29 * 12
MCC-167	Microwave Cable	Junkosha	MWX221	1404S374(1m) / 1405S074(5m)	RE	2016/05/20 * 12
MPA-11	MicroWave System Amplifier	Agilent	83017A	MY39500779	RE	2016/03/24 * 12
MMM-08	DIGITAL HiTESTER	Hioki	3805	051201197	RE	2016/01/13 * 12
MHA-16	Horn Antenna 15-40GHz	Schwarzbeck	BBHA9170	BBHA9170306	RE	2016/05/29 * 12
MHA-29	Horn Antenna 26.5-40GHz	ETS LINDGREN	3160-10	00152399	RE	2016/09/28 * 12
MCC-55	Microwave Cable	Suhner	SUCOFLEX101	2874(1m) / 2877(5m)	RE	2016/03/28 * 12
MPA-22	Pre Amplifier	MITEQ, Inc	AMF-6F-2600400-3 3-8P / AMF-4F-2600400-3 3-8P	1871355 /1871328	RE	2016/09/06 * 12
MSA-03	Spectrum Analyzer	Agilent	E4448A	MY44020357	RE	2016/05/19 * 12
MTR-08	Test Receiver	Rohde & Schwarz	ESCI	100767	RE	2016/09/15 * 12
MBA-03	Biconical Antenna	Schwarzbeck	BBA9106	1915	RE	2016/10/15 * 12
MLA-22	Logperiodic Antenna(200-1000MHz)	Schwarzbeck	VUSLP9111B	911B-191	RE	2016/01/30 * 12
MCC-51	Coaxial cable	UL Japan	-	-	RE	2016/07/26 * 12
MAT-98	Attenuator	KEYSIGHT	8491A	MY52462349	RE	2016/12/05 * 12
MPA-13	Pre Amplifier	SONOMA INSTRUMENT	310	260834	RE	2016/03/24 * 12

**UL Japan, Inc.**

**Ise EMC Lab.**

4383-326 Asama-cho, Ise-shi, Mie-ken 516-0021 JAPAN

Telephone : +81 596 24 8999

Facsimile : +81 596 24 8124

**The expiration date of the calibration is the end of the expired month.**

**All equipment is calibrated with valid calibrations. Each measurement data is traceable to the national or international standards.**

**As for some calibrations performed after the tested dates, those test equipment have been controlled by means of an unbroken chains of calibrations.**

**Test Item: RE: Radiated Emission  
AT: Antenna Terminal Conducted test**