



RADIO TEST REPORT

Test Report No. : 12486805H-B-R2

Applicant : Panasonic Corporation of North America
Type of Equipment : Wireless LAN Module
Model No. : WJ-VR3004
FCC ID : ACJ9TAWJ-VR3004
Test regulation : FCC Part 15 Subpart E: 2018
For Permissive change
(Radiated Spurious Emission tests only)
Test Result : Complied

1. This test report shall not be reproduced in full or partial, without the written approval of UL Japan, Inc.
2. The results in this report apply only to the sample tested.
3. This sample tested is in compliance with the above regulation.
4. The test results in this report are traceable to the national or international standards.
5. This test report covers Radio technical requirements. It does not cover administrative issues such as Manual or non-Radio test related Requirements. (if applicable)
6. The all test items in this test report are conducted by UL Japan, Inc. Ise EMC Lab.
7. This test report must not be used by the customer to claim product certification, approval, or endorsement by NVLAP, NIST, or any agency of the Federal Government.
8. This report is a revised version of 12486805H-B-R1. 12486805H-B-R1 is replaced with this report.

Date of test: September 20 to 27, 2018

Representative test engineer: 
Takafumi Noguchi
Engineer
Consumer Technology Division

Approved by: 
Tsubasa Takayama
Leader
Consumer Technology Division

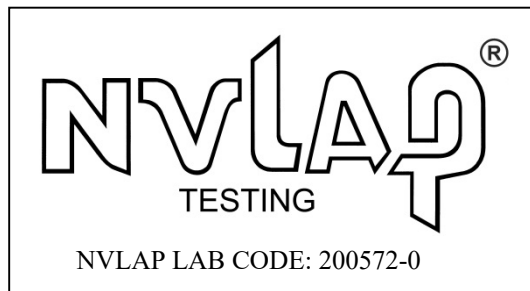

This laboratory is accredited by the NVLAP LAB CODE 200572-0, U.S.A. The tests reported herein have been performed in accordance with its terms of accreditation.
*As for the range of Accreditation in NVLAP, you may refer to the WEB address,
http://japan.ul.com/resources/emc_accredited/

- The testing in which "Non-accreditation" is displayed is outside the accreditation scopes in UL Japan.
 There is no testing item of "Non-accreditation".

UL Japan, Inc.
Ise EMC Lab.

4383-326 Asama-cho, Ise-shi, Mie-ken 516-0021 JAPAN
Telephone : +81 596 24 8999
Facsimile : +81 596 24 8124

CONTENTS	PAGE
SECTION 1: Customer information.....	4
SECTION 2: Equipment under test (E.U.T.).....	4
SECTION 3: Test specification, procedures & results.....	5
SECTION 4: Operation of E.U.T. during testing.....	8
SECTION 5: Radiated Spurious Emission and Band Edge Compliance.....	11
APPENDIX 1: Test data	14
Radiated Spurious Emission	14
APPENDIX 2: Test instruments	32
APPENDIX 3: Photographs of test setup	33
Radiated Spurious Emission	33
Worst Case Position	34

SECTION 1: Customer information

Company Name : Panasonic Corporation*
Address : 1-62, 4-chome, Minoshima, Hakata-ku, Fukuoka 812-853 Japan
Telephone Number : +81-50-3380-1993
Facsimile Number : +81-50-3380-2002
Contact Person : Koji Yamasaki

* Panasonic Corporation is on behalf of the applicant: Panasonic Corporation of North America.

SECTION 2: Equipment under test (E.U.T.)

2.1 Identification of E.U.T.

Type of Equipment : Wireless LAN Module
Model No. : WJ-VR3004
Serial No. : Refer to Section 4, Clause 4.2
Rating : DC10.5 V
Receipt Date of Sample : September 14, 2018
Country of Mass-production : Japan
Condition of EUT : Production prototype
(Not for Sale: This sample is equivalent to mass-produced items.)
Modification of EUT : No Modification by the test lab

2.2 Product Description

Model: WJ-VR3004 (referred to as the EUT in this report) is a Wireless LAN Module.

General Specification

Clock frequency(ies) in the system : 32.768 kHz, 38.4 MHz

Radio Specification

[WLAN (IEEE802.11a/b/g/n-20)]

Equipment Type	Transceiver	
Frequency of Operation	2412 MHz – 2462 MHz	W53: 5280 -5320 MHz *1) W58: 5745 MHz -5825 MHz *1)
Type of Modulation	DSSS, OFDM	OFDM
Antenna Type	Dual (Pattern)	
Antenna connecter type	Module side: Rectangular Coaxial Connector (SMT) Antenna side: RP-SMA	
Antenna Gain with cable loss	3.9145 dBi (2.4 GHz)	0.24 dBi (5 GHz)

[WLAN (IEEE802.11n-40)]

Equipment Type	Transceiver	
Frequency of Operation	2422 MHz – 2452 MHz	W53: 5310 MHz *1) MHzW58: 5755 MHz - 5795 MHz *1)
Type of Modulation	OFDM	OFDM
Antenna Type	Dual (Pattern)	
Antenna connecter type	Module side: Rectangular Coaxial Connector (SMT) Antenna side: RP-SMA	
Antenna Gain with cable loss	3.9145 dBi (2.4 GHz)	0.24 dBi (5 GHz)

*1) This test report applies to Wireless LAN (5 GHz Band).

UL Japan, Inc.

Ise EMC Lab.

4383-326 Asama-cho, Ise-shi, Mie-ken 516-0021 JAPAN
Telephone : +81 596 24 8999
Facsimile : +81 596 24 8124

SECTION 3: Test specification, procedures & results

3.1 Test Specification

Test Specification : FCC Part 15 Subpart E
FCC Part 15 final revised on March 12, 2018 and effective April 11, 2018

Title : FCC 47CFR Part15 Radio Frequency Device Subpart E
Unlicensed National Information Infrastructure Devices
Section 15.407 General technical requirements

3.2 Procedures and results

Item	Test Procedure	Specification	Worst margin	Results	Remarks
Spurious Emission Restricted Band Edge	FCC: ANSI C63.10-2013 KDB Publication Number 789033 IC: -	FCC: 15.407 (b), 15.205 and 15.209 IC: RSS-247 6.2.1.2 6.2.2.2 6.2.3.2 6.2.4.2	12.2 dB 267.235 MHz, QP, Vert.	Complied	Conducted (< 30 MHz)/ Radiated (> 30 MHz) *1)
Note: UL Japan, Inc.'s EMI Work Procedures No. 13-EM-W0420 and 13-EM-W0422. *1) Radiated test was selected over 30 MHz based on section FCC 15.407 (b) and KDB 789033 D02 G.3.b).					
Symbols: Complied The data of this test item has enough margin, more than the measurement uncertainty. Complied# The data of this test item meets the limits unless the measurement uncertainty is taken into consideration.					

* In case any questions arise about test procedure, ANSI C63.10: 2013 is also referred.

FCC 15.31 (e)

The RF Module has its own regulator.

The RF Module is constantly provided voltage through the regulator regardless of input voltage. Therefore, this EUT complies with the requirement.

FCC Part 15.203/212 Antenna requirement

The EUT has a unique coupling/antenna connector (Module side: Rectangular Coaxial Connector (SMT), Antenna side: RP-SMA). Therefore the equipment complies with the requirement of 15.203/212.

3.3 Addition to standard

No addition, exclusion nor deviation has been made from the standard.

3.4 Uncertainty

EMI

The following uncertainties have been calculated to provide a confidence level of 95 % using a coverage factor $k=2$.

Radiated emission

Measurement distance	Frequency range	Uncertainty (+/-)
3 m	9 kHz to 30 MHz	3.3 dB
10 m		3.2 dB
3 m	30 MHz to 200 MHz (Horizontal)	4.8 dB
		(Vertical) 5.0 dB
	200 MHz to 1000 MHz (Horizontal)	5.2 dB
		(Vertical) 6.3 dB
10 m	30 MHz to 200 MHz (Horizontal)	4.8 dB
		(Vertical) 4.9 dB
	200 MHz to 1000 MHz (Horizontal)	5.0 dB
		(Vertical) 5.0 dB
3 m	1 GHz to 6 GHz	5.0 dB
	6 GHz to 18 GHz	5.3 dB
1 m	10 GHz to 26.5 GHz	5.8 dB
	26.5 GHz to 40 GHz	5.8 dB
10 m	1 GHz to 18 GHz	5.2 dB

3.5 Test Location

UL Japan, Inc. Ise EMC Lab.

4383-326 Asama-cho, Ise-shi, Mie-ken 516-0021 JAPAN

Telephone: +81 596 24 8999, Facsimile: +81 596 24 8124

NVLAP Lab. code: 200572-0 / FCC Test Firm Registration Number: 199967

Test site	IC Registration Number	Width x Depth x Height (m)	Size of reference ground plane (m) / horizontal conducting plane	Other rooms	Maximum measurement distance
No.1 semi-anechoic chamber	2973C-1	19.2 x 11.2 x 7.7	7.0 x 6.0	No.1 Power source room	10 m
No.2 semi-anechoic chamber	2973C-2	7.5 x 5.8 x 5.2	4.0 x 4.0	-	3 m
No.3 semi-anechoic chamber	2973C-3	12.0 x 8.5 x 5.9	6.8 x 5.75	No.3 Preparation room	3 m
No.3 shielded room	-	4.0 x 6.0 x 2.7	N/A	-	-
No.4 semi-anechoic chamber	2973C-4	12.0 x 8.5 x 5.9	6.8 x 5.75	No.4 Preparation room	3 m
No.4 shielded room	-	4.0 x 6.0 x 2.7	N/A	-	-
No.5 semi-anechoic chamber	-	6.0 x 6.0 x 3.9	6.0 x 6.0	-	-
No.6 shielded room	-	4.0 x 4.5 x 2.7	4.0 x 4.5	-	-
No.6 measurement room	-	4.75 x 5.4 x 3.0	4.75 x 4.15	-	-
No.7 shielded room	-	4.7 x 7.5 x 2.7	4.7 x 7.5	-	-
No.8 measurement room	-	3.1 x 5.0 x 2.7	N/A	-	-
No.9 measurement room	-	8.8 x 4.6 x 2.8	2.4 x 2.4	-	-
No.11 measurement room	-	6.2 x 4.7 x 3.0	4.8 x 4.6	-	-

* Size of vertical conducting plane (for Conducted Emission test) : 2.0 x 2.0 m for No.1, No.2, No.3, and No.4 semi-anechoic chambers and No.3 and No.4 shielded rooms.

3.6 Test data, Test instruments, and Test set up

Refer to APPENDIX.

UL Japan, Inc.

Ise EMC Lab.

4383-326 Asama-cho, Ise-shi, Mie-ken 516-0021 JAPAN

Telephone : +81 596 24 8999

Facsimile : +81 596 24 8124

SECTION 4: Operation of E.U.T. during testing

4.1 Operating Mode(s)

Test operating mode was determined as follows according to “Section 1 of 6 802.11 a/b/g/n testing - Managing Complex Regulatory Approvals -” of TCB Council Workshop October 2009.

Mode	Remarks*
IEEE 802.11a (11a)	12Mbps, PN9
IEEE 802.11n MIMO 20MHz BW (11n-20): 5GHz Band	MCS 13, PN9
IEEE 802.11n MIMO 40MHz BW (11n-40) : 5GHz Band	MCS 15, PN9
*The worst condition was determined based on the test result of Maximum Conducted Output Power (Mid Channel)	
*Power of the EUT was set by the software as follows; - Power settings: 12 dBm - Software: Dut Wlan BT Labtool Version 1.0.8.1.6 *This setting of software is the worst case. Any conditions under the normal use do not exceed the condition of setting. In addition, end users cannot change the settings of the output power of the product.	

*The details of Operation mode(s)

Test Item	Operating Mode	Antenna	Tested Frequency		
			Low Band	Middle Band	Additional Band
Spurious Emission (Radiated)	11n-20 Tx *1)	A+B	-	5280MHz 5300MHz 5320MHz	5745MHz 5785MHz 5825MHz
	----- 11n-40 Tx		----- -	----- 5310MHz	----- 5755MHz 5795MHz
*1) Since 11a and 11n-20 have the same modulation method and no differences in transmitting specification, test was performed on the representative mode that had the highest peak output power.					

UL Japan, Inc.

Ise EMC Lab.

4383-326 Asama-cho, Ise-shi, Mie-ken 516-0021 JAPAN

Telephone : +81 596 24 8999

Facsimile : +81 596 24 8124

4.2 Configuration and peripherals

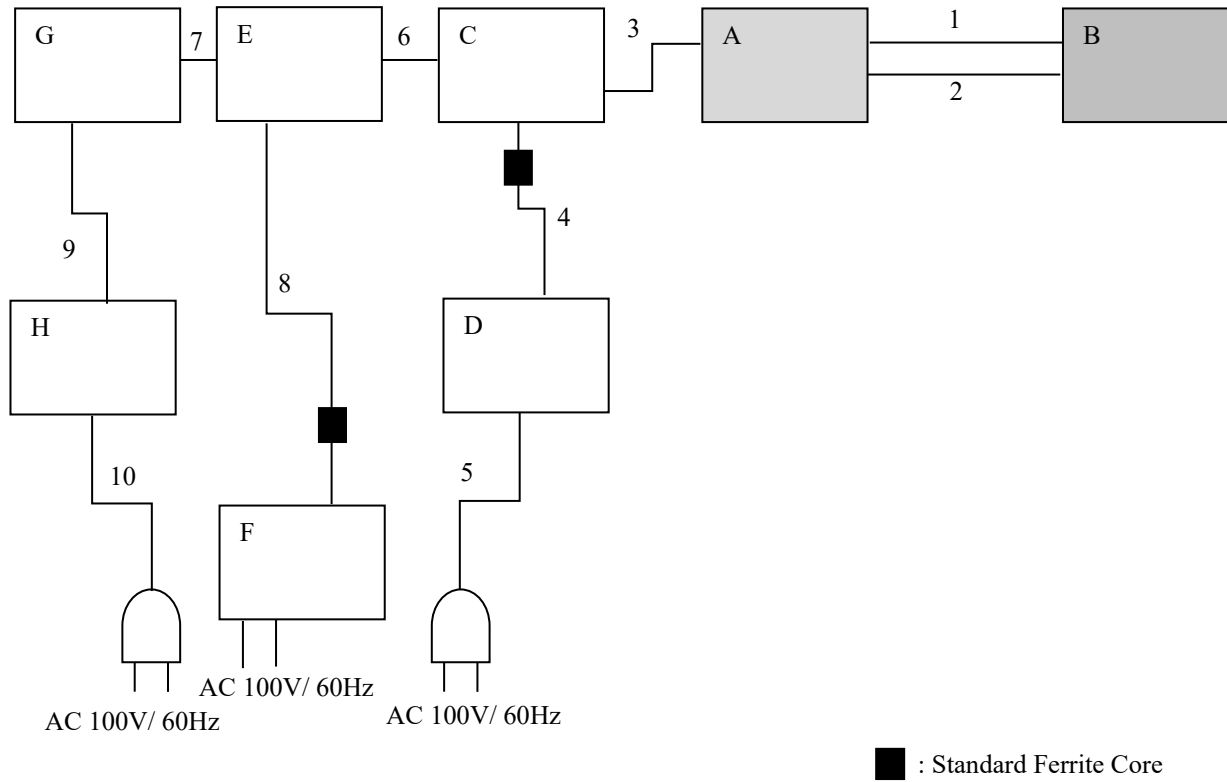

* Cabling and setup(s) were taken into consideration and test data was taken under worse case conditions.

Description of EUT and Support equipment

No.	Item	Model number	Serial number	Manufacturer	Remarks
A	Wireless LAN Module	WJ-VR3004	PJA00186	Panasonic	EUT
B	Double Wi-Fi Antenna	AP-PAN-WW-Q-S22-RP -BL-18 (ARB-APWWQS22-RP- BL)	-	Airgain, Inc. (Panasonic)	EUT
C	Laptop PC	CF-31	OJKSA31800	Panasonic	-
D	AC Adaptor	CF-AA1653A	04209776B	Panasonic	-
E	Switching Hub	CG-SW05GTPLW	1077580071100385	Corega	-
F	AC Adaptor	MU10-4033200A-1	-	Corega	-
G	Laptop PC	ProBook 6560b	-	HP	-
H	AC Adaptor	PPP009L-E	WBGST0A4LZTT08	HP	-

List of cables used

No.	Name	Length (m)	Shield		Remarks
			Cable	Connector	
1	Antenna Cable	5.5	Shielded	Shielded	-
2	Antenna Cable	5.5	Shielded	Shielded	-
3	USB Cable	3.0	Shielded	Shielded	-
4	DC Cable	2.0	Unshielded	Unshielded	-
5	AC Cable	2.0	Unshielded	Unshielded	-
6	LAN Cable	1.0	Unshielded	Unshielded	-
7	LAN Cable	2.0	Unshielded	Unshielded	-
8	DC Cable	2.0	Unshielded	Unshielded	-
9	DC Cable	2.0	Unshielded	Unshielded	-
10	AC Cable	2.0	Unshielded	Unshielded	-

UL Japan, Inc.

Ise EMC Lab.

4383-326 Asama-cho, Ise-shi, Mie-ken 516-0021 JAPAN

Telephone : +81 596 24 8999

Facsimile : +81 596 24 8124

SECTION 5: Radiated Spurious Emission and Band Edge Compliance

Test Procedure

< Below 1GHz >

EUT was placed on a urethane platform of nominal size, 0.5 m by 1.0 m, raised 0.8 m above the conducting ground plane. The Radiated Electric Field Strength has been measured in a Semi Anechoic Chamber with a ground plane.

< Above 1GHz >

EUT was placed on a urethane platform of nominal size, 0.5 m by 0.5 m, raised 1.5 m above the conducting ground plane.

The Radiated Electric Field Strength has been measured in a Semi Anechoic Chamber with absorbent materials lined on a ground plane.

The height of the measuring antenna varied between 1 and 4 m and EUT was rotated a full revolution in order to obtain the maximum value of the electric field strength.

The measurements were performed for both vertical and horizontal antenna polarization with the Test Receiver, or the Spectrum Analyzer.

The measurements were made with the following detector function of the test receiver and the Spectrum analyzer (in linear mode).

The test was made with the detector (RBW/VBW) in the following table.

When using Spectrum analyzer, the test was made with adjusting span to zero by using peak hold.

< Below 1GHz >

The result also satisfied with the general limits specified in section 15.209 (a).

< Above 1GHz >

Inside of restricted bands (Section 15.205):

Apply to limit in the Section 15.209 (a).

Outside of the restricted bands:

Apply to limit 68.2 dBuV/m, 3 m (-27 dBm e.i.r.p.*) in the Section 15.407 (b) (2) (4).

For W58 Bandedge

-27 dBm/MHz at 75 MHz or more above or below the band edge increasing linearly to 10 dBm/MHz at 25 MHz above or below the band edge, and from 25 MHz above or below the band edge increasing linearly to a level of 15.6 dBm/MHz at 5 MHz above or below the band edge, and from 5 MHz above or below the band edge increasing linearly to a level of 27 dBm/MHz at the band edge in the section 15.407(b)(4)(i)
Or, apply to limit in the section 15.209 (a).

Restricted band edge:

Apply to limit in the Section 15.209 (a).

Since this limit is severer than the limit of the inside of restricted bands.

*Electric field strength to e.i.r.p. conversion:

$$E = \frac{1000000\sqrt{30P}}{3} \text{ (uV/m)} \quad :P \text{ is the e.i.r.p. (Watts)}$$

Test Antennas are used as below;

Frequency	30 MHz to 200 MHz	200 MHz to 1 GHz	Above 1 GHz
Antenna Type	Biconical	Logperiodic	Horn

Frequency	Below 1 GHz	Above 1 GHz	
Instrument used	Test Receiver	Spectrum Analyzer	
Detector	QP	Peak	Average
IF Bandwidth	BW: 120 kHz	RBW: 1 MHz VBW: 3 MHz	Method AD *1) RBW: 1 MHz VBW: 3 MHz Detector: Power Averaging (RMS) Trace: ≥ 100 traces If duty cycle was less than 98%, a duty factor was added to the results.

*1) The test method was also referred to KDB 789033 D02 General UNII Test Procedures New Rules v02r01 "Guidelines for Compliance Testing of Unlicensed National Information Infrastructure (U-NII) Devices Part 15, Subpart E".

Figure 1: Test Setup

Below 1 GHz

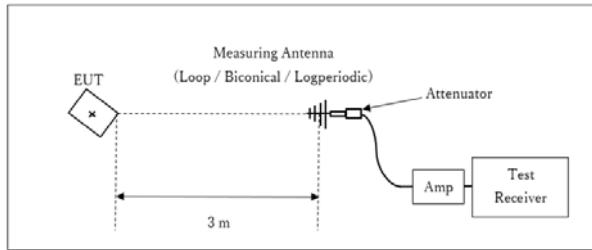

× : Center of turn table

Test Distance: 3 m

1 GHz - 10 GHz

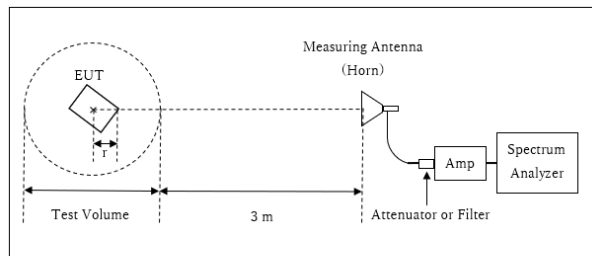

r : Radius of an outer periphery of EUT
× : Center of turn table

Distance Factor: $20 \times \log(4 \text{ m} / 3.0 \text{ m}) = 2.5 \text{ dB}$
* Test Distance: $(3 + \text{Test Volume} / 2) - r = 4.0 \text{ m}$

Test Volume : 2.0 m
(Test Volume has been calibrated based on CISPR 16-1-4.)
r = 0.0 m

* The test was performed with r = 0.0 m since EUT is small and it was the rather conservative condition.

10 GHz - 40 GHz

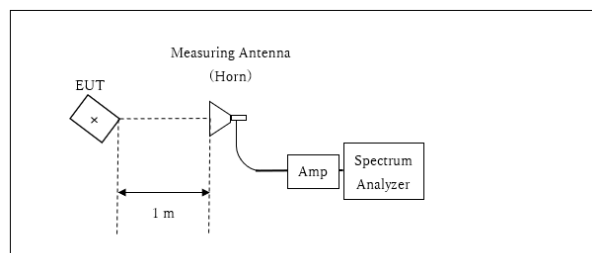

× : Center of turn table

Distance Factor: $20 \times \log(1.0 \text{ m} / 3.0 \text{ m}) = -9.5 \text{ dB}$
*Test Distance: 1 m

- The carrier level and noise levels were confirmed at each position of X, Y and Z axes of EUT and Antenna to see the position of maximum noise, and the test was made at the position that has the maximum noise.

The test results and limit are rounded off to one decimal place, so some differences might be observed.

Measurement range : 30 MHz - 40 GHz
Test data : APPENDIX
Test result : Pass

APPENDIX 1: Test data

Radiated Spurious Emission

Report No. 12486805H
Test place Ise EMC Lab.
Semi Anechoic Chamber No.4 No.1
Date September 20, 2018 September 25, 2018
Temperature / Humidity 22 deg. C / 53 % RH 24 deg. C / 68 % RH
Engineer Akihiko Maeda Takafumi Noguchi
(1 GHz - 10 GHz) (10 GHz - 40 GHz)
Mode Tx 11n-20 5280 MHz

Polarity	Frequency [MHz]	Detector	Reading [dBuV]	Ant.Fac. [dB/m]	Loss [dB]	Gain [dB]	Duty Factor [dB]	Result [dBuV/m]	Limit [dBuV/m]	Margin [dB]	Remark
Hori	5250.000	PK	40.8	31.6	4.0	31.7	-	44.7	68.2	23.5	
Hori	10560.000	PK	43.6	39.2	-2.6	36.4	-	43.8	68.2	24.4	Floor noise
Hori	15840.000	PK	45.8	36.9	-0.7	36.7	-	45.3	73.9	28.6	Floor noise
Hori	15840.000	AV	37.6	36.9	-0.7	36.7	-	37.1	53.9	16.8	Floor noise
Vert	5250.000	PK	40.0	31.6	4.0	31.7	-	43.9	68.2	24.3	
Vert	10560.000	PK	42.8	39.2	-2.6	36.4	-	43.0	68.2	25.2	Floor noise
Vert	15840.000	PK	44.5	36.9	-0.7	36.7	-	44.0	73.9	29.9	Floor noise
Vert	15840.000	AV	37.7	36.9	-0.7	36.7	-	37.2	53.9	16.7	Floor noise

Result = Reading + Ant Factor + Loss (Cable+Attenuator+Filter+Distance factor(above 1 GHz)) - Gain(Amplifier)

*Other frequency noises omitted in this report were not seen or had enough margin (more than 20 dB).

Distance factor: 1 GHz - 10 GHz 20log(4 m / 3.0 m) = 2.5 dB
10 GHz - 40 GHz 20log(1.0 m / 3.0 m) = -9.5 dB

UL Japan, Inc.

Ise EMC Lab.

4383-326 Asama-cho, Ise-shi, Mie-ken 516-0021 JAPAN

Telephone : +81 596 24 8999

Facsimile : +81 596 24 8124

Radiated Spurious Emission

Report No.	12486805H
Test place	Ise EMC Lab.
Semi Anechoic Chamber	No.4
Date	September 20, 2018
Temperature / Humidity	22 deg. C / 53 % RH
Engineer	Akihiko Maeda
Mode	Tx 11n-20 5280 MHz

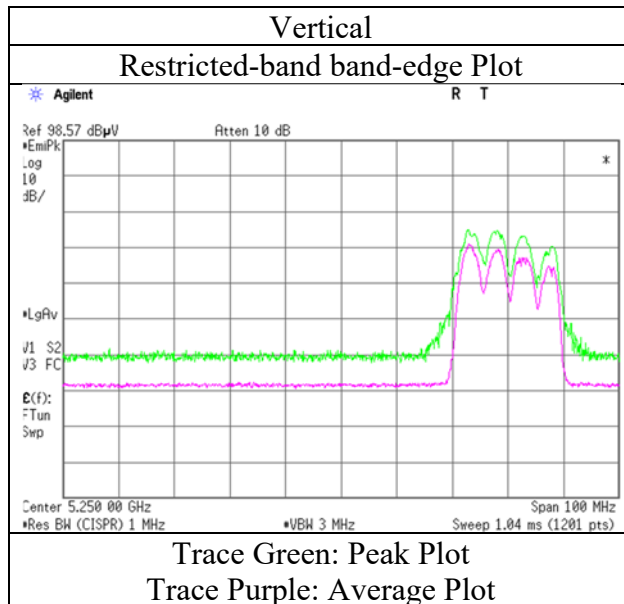
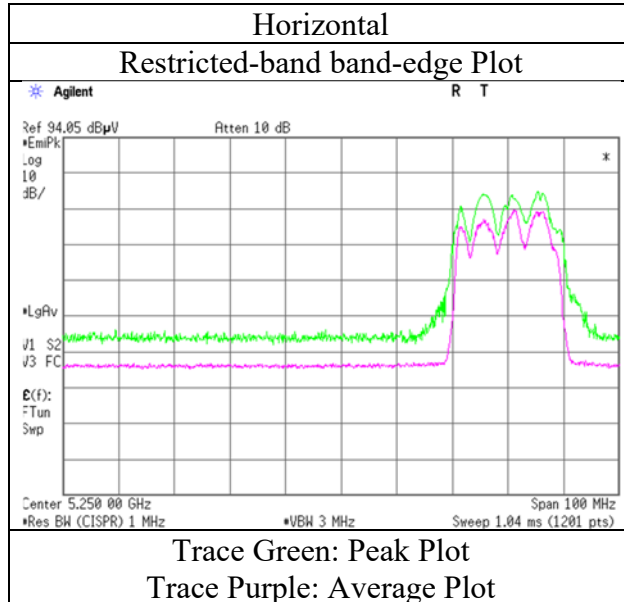

* Final result of restricted band edge was shown in tabular data.

Radiated Spurious Emission

Report No.	12486805H	
Test place	Ise EMC Lab.	
Semi Anechoic Chamber	No.4	No.1
Date	September 20, 2018	September 25, 2018
Temperature / Humidity	22 deg. C / 53 % RH	24 deg. C / 68 % RH
Engineer	Akihiko Maeda	Takafumi Noguchi
	(1 GHz - 10 GHz)	(10 GHz - 40 GHz)
Mode	Tx 11n-20 5300 MHz	

Polarity	Frequency [MHz]	Detector	Reading [dBuV]	Ant.Fac. [dB/m]	Loss [dB]	Gain [dB]	Duty Factor [dB]	Result [dBuV/m]	Limit [dBuV/m]	Margin [dB]	Remark
Hori	10600.000	PK	45.7	39.3	-2.6	36.3	-	46.1	73.9	27.8	Floor noise
Hori	15900.000	PK	45.2	37.0	-0.7	36.7	-	44.8	73.9	29.1	Floor noise
Hori	10600.000	AV	36.5	39.3	-2.6	36.3	-	36.9	53.9	17.0	Floor noise
Hori	15900.000	AV	35.8	37.0	-0.7	36.7	-	35.4	53.9	18.5	Floor noise
Vert	10600.000	PK	43.9	39.3	-2.6	36.3	-	44.3	73.9	29.6	Floor noise
Vert	15900.000	PK	45.7	37.0	-0.7	36.7	-	45.3	73.9	28.6	Floor noise
Vert	10600.000	AV	35.9	39.3	-2.6	36.3	-	36.3	53.9	17.6	Floor noise
Vert	15900.000	AV	37.6	37.0	-0.7	36.7	-	37.2	53.9	16.7	Floor noise

Result = Reading + Ant Factor + Loss (Cable+Attenuator+Filter+Distance factor(above 1 GHz)) - Gain(Amplifier)

*Other frequency noises omitted in this report were not seen or had enough margin (more than 20 dB).

Distance factor: 1 GHz - 10 GHz $20\log(4\text{ m} / 3.0\text{ m}) = 2.5\text{ dB}$
 10 GHz - 40 GHz $20\log(1.0\text{ m} / 3.0\text{ m}) = -9.5\text{ dB}$

Radiated Spurious Emission

Report No.	12486805H		
Test place	Ise EMC Lab.		
Semi Anechoic Chamber	No.4	No.1	No.1
Date	September 20, 2018	September 25, 2018	September 27, 2018
Temperature / Humidity	22 deg. C / 53 % RH	24 deg. C / 68 % RH	24 deg. C / 68 % RH
Engineer	Akihiko Maeda	Takafumi Noguchi	Takafumi Noguchi
	(1 GHz - 10 GHz)	(10 GHz - 40 GHz)	(30 MHz - 1000 MHz)
Mode	Tx 11n-20 5320 MHz		

Polarity	Frequency [MHz]	Detector	Reading [dBuV]	Ant.Fac. [dB/m]	Loss [dB]	Gain [dB]	Duty Factor [dB]	Result [dBuV/m]	Limit [dBuV/m]	Margin [dB]	Remark
Hori	46.008	QP	35.4	12.5	7.7	38.9	-	16.7	40.0	23.3	
Hori	54.938	QP	40.7	9.3	7.8	38.9	-	18.9	40.0	21.1	
Hori	193.376	QP	36.8	16.5	9.7	39.0	-	24.0	43.5	19.5	
Hori	246.957	QP	42.4	11.6	10.2	38.9	-	25.3	46.0	20.7	
Hori	480.016	QP	40.7	17.5	12.0	38.5	-	31.7	46.0	14.3	
Hori	721.044	QP	33.2	20.1	13.6	38.3	-	28.6	46.0	17.4	
Hori	5350.000	PK	40.3	31.6	6.5	31.8	-	46.6	73.9	27.3	
Hori	10640.000	PK	43.8	39.4	-2.6	36.3	-	44.3	73.9	29.6	Floor noise
Hori	15960.000	PK	45.7	37.0	-0.7	36.8	-	45.2	73.9	28.7	Floor noise
Hori	5350.000	AV	29.7	31.6	6.5	31.8	-	36.0	53.9	17.9	
Hori	10640.000	AV	34.5	39.4	-2.6	36.3	-	35.0	53.9	18.9	Floor noise
Hori	15960.000	AV	36.5	37.0	-0.7	36.8	-	36.0	53.9	17.9	Floor noise
Vert	46.000	QP	44.7	12.5	7.7	38.9	-	26.0	40.0	14.0	
Vert	88.543	QP	48.3	7.7	8.4	38.9	-	25.5	43.5	18.0	
Vert	105.230	QP	44.8	10.8	8.6	39.0	-	25.2	43.5	18.3	
Vert	267.235	QP	49.8	12.5	10.4	38.9	-	33.8	46.0	12.2	
Vert	338.996	QP	42.1	14.8	11.0	38.7	-	29.2	46.0	16.8	
Vert	415.529	QP	40.7	16.0	11.6	38.6	-	29.7	46.0	16.3	
Vert	5350.000	PK	40.1	31.6	6.5	31.8	-	46.4	73.9	27.5	
Vert	10640.000	PK	43.7	39.4	-2.6	36.3	-	44.2	73.9	29.7	Floor noise
Vert	15960.000	PK	45.9	37.0	-0.7	36.8	-	45.4	73.9	28.5	Floor noise
Vert	5350.000	AV	31.4	31.6	6.5	31.8	-	37.7	53.9	16.2	
Vert	10640.000	AV	35.7	39.4	-2.6	36.3	-	36.2	53.9	17.7	Floor noise
Vert	15960.000	AV	36.4	37.0	-0.7	36.8	-	35.9	53.9	18.0	Floor noise

Result = Reading + Ant Factor + Loss (Cable+Attenuator+Filter+Distance factor(above 1 GHz)) - Gain(Amplifier)

*Other frequency noises omitted in this report were not seen or had enough margin (more than 20 dB).

Distance factor: 1 GHz - 10 GHz 20log (4 m / 3.0 m) = 2.5 dB
 10 GHz - 40 GHz 20log (1.0 m / 3.0 m) = -9.5 dB

Radiated Spurious Emission

Report No.	12486805H
Test place	Ise EMC Lab.
Semi Anechoic Chamber	No.4
Date	September 20, 2018
Temperature / Humidity	22 deg. C / 53 % RH
Engineer	Akihiko Maeda
Mode	Tx 11n-20 5320 MHz

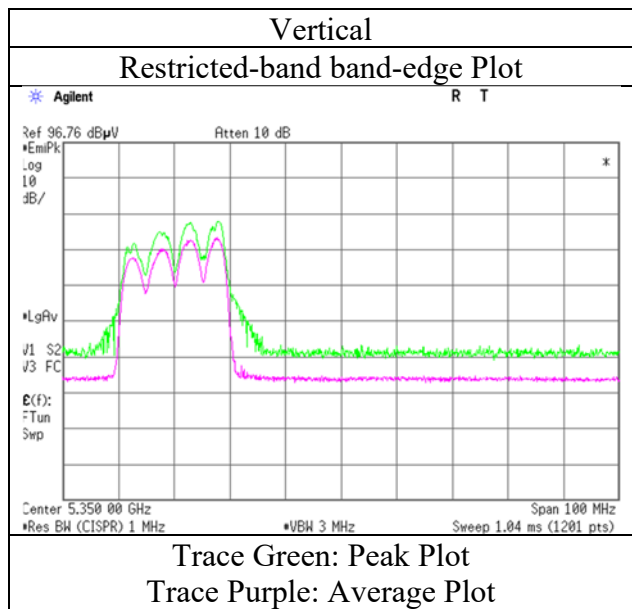
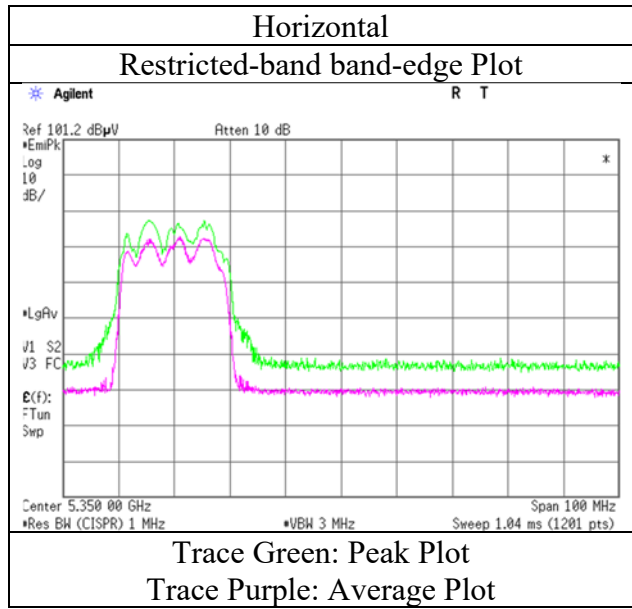

* Final result of restricted band edge was shown in tabular data.

Radiated Spurious Emission

Report No.	12486805H	
Test place	Ise EMC Lab.	
Semi Anechoic Chamber	No.4	No.1
Date	September 20, 2018	September 25, 2018
Temperature / Humidity	22 deg. C / 53 % RH	24 deg. C / 68 % RH
Engineer	Akihiko Maeda	Takafumi Noguchi
	(1 GHz - 10 GHz)	(10 GHz - 40 GHz)
Mode	Tx 11n-40 5310 MHz	

Polarity	Frequency [MHz]	Detector	Reading [dBuV]	Ant.Fac. [dB/m]	Loss [dB]	Gain [dB]	Duty Factor [dB]	Result [dBuV/m]	Limit [dBuV/m]	Margin [dB]	Remark
Hori	5250.000	PK	39.8	31.6	6.5	31.7	-	46.2	73.9	27.7	
Hori	5350.000	PK	40.4	31.6	6.5	31.8	-	46.7	73.9	27.2	
Hori	10620.000	PK	43.8	39.3	-2.6	36.3	-	44.2	73.9	29.7	Floor noise
Hori	15930.000	PK	46.2	37.0	-0.7	36.8	-	45.7	73.9	28.2	Floor noise
Hori	5350.000	AV	31.3	31.6	6.5	31.8	-	37.6	53.9	16.3	
Hori	10620.000	AV	34.4	39.3	-2.6	36.3	-	34.8	53.9	19.1	Floor noise
Hori	15930.000	AV	37.0	37.0	-0.7	36.8	-	36.5	53.9	17.4	Floor noise
Vert	5250.000	PK	39.8	31.6	6.5	31.7	-	46.2	73.9	27.7	
Vert	5350.000	PK	39.4	31.6	6.5	31.8	-	45.7	73.9	28.2	
Vert	10620.000	PK	44.6	39.3	-2.6	36.3	-	45.0	73.9	28.9	Floor noise
Vert	15930.000	PK	45.7	37.0	-0.7	36.8	-	45.2	73.9	28.7	Floor noise
Vert	5350.000	AV	32.1	31.6	6.5	31.8	-	38.4	53.9	15.5	
Vert	10620.000	AV	36.2	39.3	-2.6	36.3	-	36.6	53.9	17.3	Floor noise
Vert	15930.000	AV	35.9	37.0	-0.7	36.8	-	35.4	53.9	18.5	Floor noise

Result = Reading + Ant Factor + Loss (Cable+Attenuator+Filter+Distance factor(above 1 GHz)) - Gain(Amplifier)

*Other frequency noises omitted in this report were not seen or had enough margin (more than 20 dB).

Distance factor: 1 GHz - 10 GHz $20\log(4\text{ m} / 3.0\text{ m}) = 2.5\text{ dB}$
 10 GHz - 40 GHz $20\log(1.0\text{ m} / 3.0\text{ m}) = -9.5\text{ dB}$

Radiated Spurious Emission

Report No.	12486805H
Test place	Ise EMC Lab.
Semi Anechoic Chamber	No.4
Date	September 20, 2018
Temperature / Humidity	22 deg. C / 53 % RH
Engineer	Akihiko Maeda
Mode	Tx 11n-40 5310 MHz

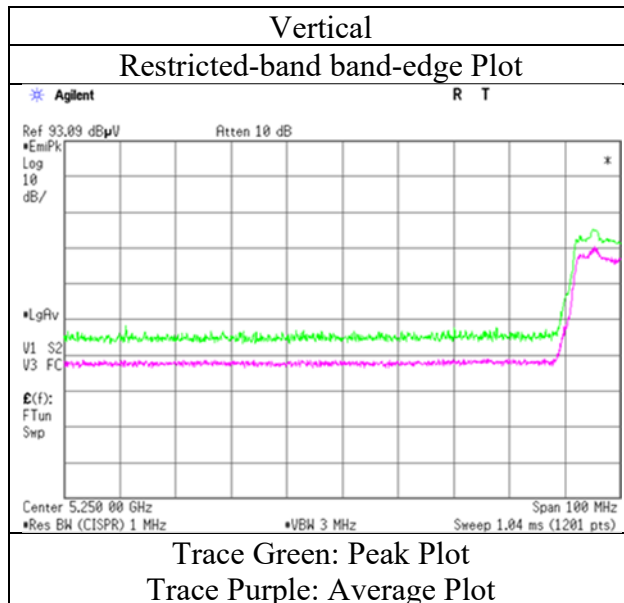
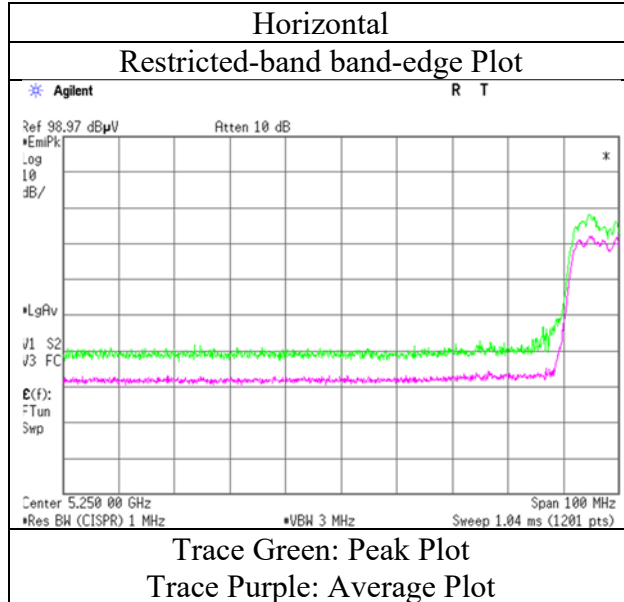

* Final result of restricted band edge was shown in tabular data.

Radiated Spurious Emission

Report No.	12486805H
Test place	Ise EMC Lab.
Semi Anechoic Chamber	No.4
Date	September 20, 2018
Temperature / Humidity	22 deg. C / 53 % RH
Engineer	Akihiko Maeda
Mode	Tx 11n-40 5310 MHz

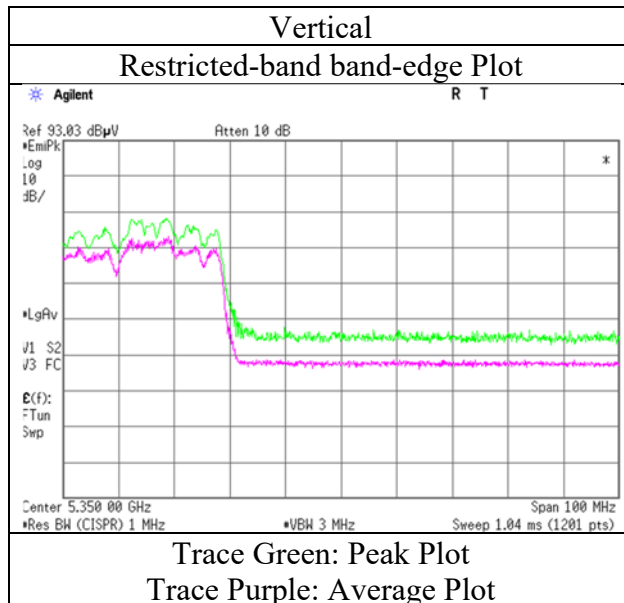
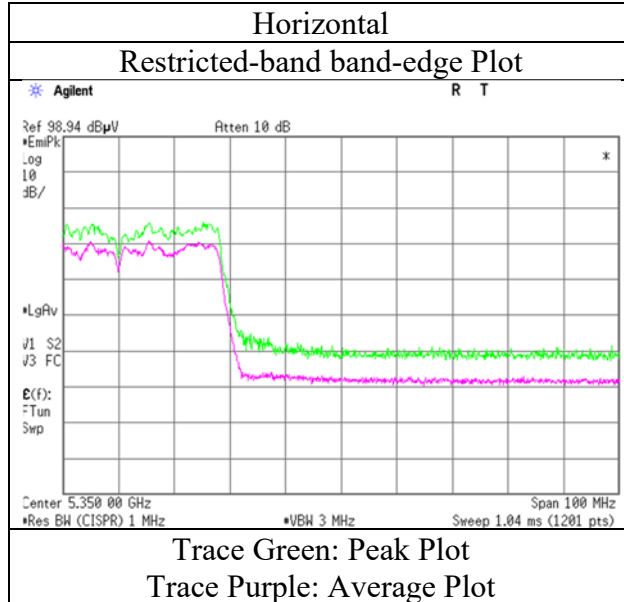

* Final result of restricted band edge was shown in tabular data.

UL Japan, Inc.

Ise EMC Lab.

4383-326 Asama-cho, Ise-shi, Mie-ken 516-0021 JAPAN

Telephone : +81 596 24 8999

Facsimile : +81 596 24 8124

Radiated Spurious Emission

Report No.	12486805H	
Test place	Ise EMC Lab.	
Semi Anechoic Chamber	No.4	No.1
Date	September 20, 2018	September 25, 2018
Temperature / Humidity	22 deg. C / 53 % RH	24 deg. C / 68 % RH
Engineer	Akihiko Maeda	Takafumi Noguchi
	(1 GHz - 10 GHz)	(10 GHz - 40 GHz)
Mode	Tx 11n-20 5745 MHz	

Polarity	Frequency [MHz]	Detector	Reading [dBuV]	Ant.Fac. [dB/m]	Loss [dB]	Gain [dB]	Duty Factor [dB]	Result [dBuV/m]	Limit [dBuV/m]	Margin [dB]	Remark
Hori	5650.000	PK	40.0	31.9	6.6	31.8	-	46.7	68.2	21.5	
Hori	5700.000	PK	40.3	32.0	6.6	31.8	-	47.1	105.2	58.1	
Hori	5720.000	PK	44.5	32.1	6.6	31.8	-	51.4	110.8	59.4	
Hori	5725.000	PK	40.6	32.1	6.6	31.8	-	47.5	122.2	74.7	
Hori	11490.000	PK	44.5	39.8	-2.3	36.0	-	46.0	73.9	27.9	Floor noise
Hori	17235.000	PK	44.9	40.7	-0.3	35.6	-	49.7	73.9	24.2	Floor noise
Hori	22980.000	PK	45.1	40.7	-1.0	35.5	-	49.3	73.9	24.6	Floor noise
Hori	11490.000	AV	34.6	39.8	-2.3	36.0	-	36.1	53.9	17.8	Floor noise
Hori	17235.000	AV	35.9	40.7	-0.3	35.6	-	40.7	53.9	13.2	Floor noise
Hori	22980.000	AV	35.2	40.7	-1.0	35.5	-	39.4	53.9	14.5	Floor noise
Vert	5650.000	PK	40.6	31.9	6.6	31.8	-	47.3	68.2	20.9	
Vert	5700.000	PK	41.4	32.0	6.6	31.8	-	48.2	105.2	57.0	
Vert	5720.000	PK	40.0	32.1	6.6	31.8	-	46.9	110.8	63.9	
Vert	5725.000	PK	40.2	32.1	6.6	31.8	-	47.1	122.2	75.1	
Vert	11490.000	PK	45.4	39.8	-2.3	36.0	-	46.9	73.9	27.0	Floor noise
Vert	17235.000	PK	45.7	40.7	-0.3	35.6	-	50.5	73.9	23.4	Floor noise
Vert	22980.000	PK	45.0	40.7	-1.0	35.5	-	49.2	73.9	24.7	Floor noise
Vert	11490.000	AV	34.6	39.8	-2.3	36.0	-	36.1	53.9	17.8	Floor noise
Vert	17235.000	AV	36.3	40.7	-0.3	35.6	-	41.1	53.9	12.8	Floor noise
Vert	22980.000	AV	35.0	40.7	-1.0	35.5	-	39.2	53.9	14.7	Floor noise

Result = Reading + Ant Factor + Loss (Cable+Attenuator+Filter+Distance factor(above 1 GHz)) - Gain(Amplifier)

*Other frequency noises omitted in this report were not seen or had enough margin (more than 20 dB).

Distance factor: 1 GHz - 10 GHz $20\log(4\text{ m} / 3.0\text{ m}) = 2.5\text{ dB}$
 10 GHz - 40 GHz $20\log(1.0\text{ m} / 3.0\text{ m}) = -9.5\text{ dB}$

Radiated Spurious Emission

Report No.	12486805H
Test place	Ise EMC Lab.
Semi Anechoic Chamber	No.4
Date	September 20, 2018
Temperature / Humidity	22 deg. C / 53 % RH
Engineer	Akihiko Maeda
Mode	Tx 11n-20 5745 MHz

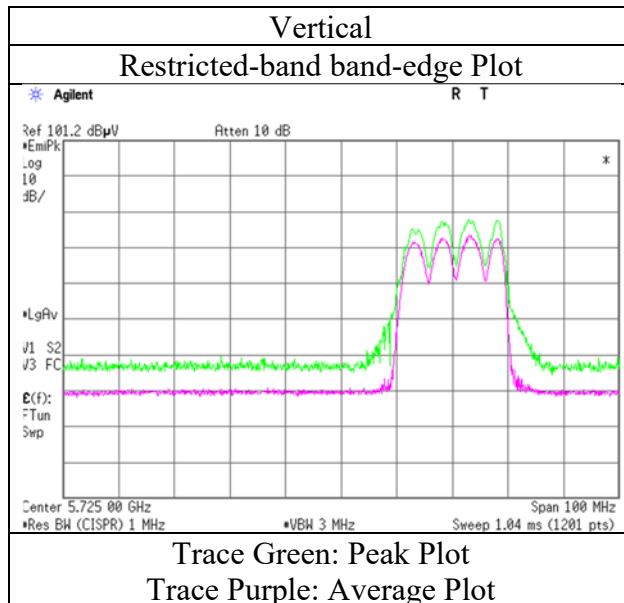
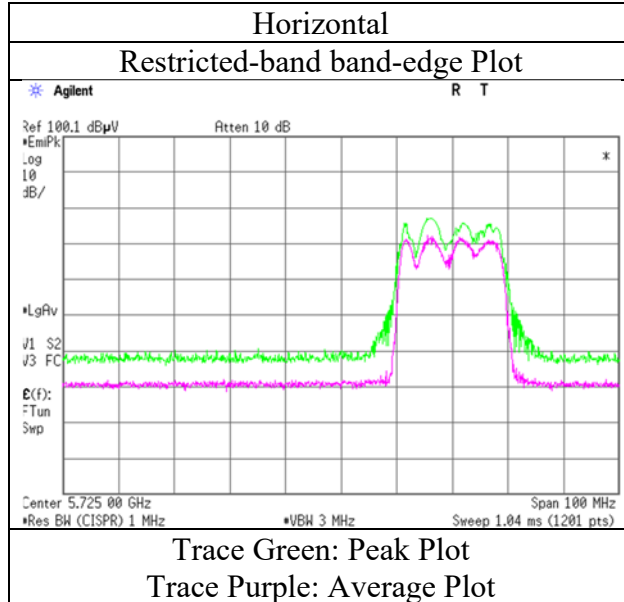

* Final result of restricted band edge was shown in tabular data.

Radiated Spurious Emission

Report No.	12486805H	
Test place	Ise EMC Lab.	
Semi Anechoic Chamber	No.4	No.1
Date	September 20, 2018	September 25, 2018
Temperature / Humidity	22 deg. C / 53 % RH	24 deg. C / 68 % RH
Engineer	Akihiko Maeda	Takafumi Noguchi
	(1 GHz - 10 GHz)	(10 GHz - 40 GHz)
Mode	Tx 11n-20 5785 MHz	

Polarity	Frequency [MHz]	Detector	Reading [dBuV]	Ant.Fac. [dB/m]	Loss [dB]	Gain [dB]	Duty Factor [dB]	Result [dBuV/m]	Limit [dBuV/m]	Margin [dB]	Remark
Hori	11570.000	PK	42.8	39.7	-2.2	36.0	-	44.3	73.9	29.6	Floor noise
Hori	17355.000	PK	45.2	41.6	-0.3	35.6	-	50.9	73.9	23.0	Floor noise
Hori	23140.000	PK	45.4	40.6	-1.0	35.5	-	49.5	73.9	24.4	Floor noise
Hori	11570.000	AV	33.9	39.7	-2.2	36.0	-	35.4	53.9	18.5	Floor noise
Hori	17355.000	AV	35.8	41.6	-0.3	35.6	-	41.5	53.9	12.4	Floor noise
Hori	23140.000	AV	35.3	40.6	-1.0	35.5	-	39.4	53.9	14.5	Floor noise
Vert	11570.000	PK	43.6	39.7	-2.2	36.0	-	45.1	73.9	28.8	Floor noise
Vert	17355.000	PK	44.7	41.6	-0.3	35.6	-	50.4	73.9	23.5	Floor noise
Vert	23140.000	PK	45.8	40.6	-1.0	35.5	-	49.9	73.9	24.0	Floor noise
Vert	11570.000	AV	34.4	39.7	-2.2	36.0	-	35.9	53.9	18.0	Floor noise
Vert	17355.000	AV	35.9	41.6	-0.3	35.6	-	41.6	53.9	12.3	Floor noise
Vert	23140.000	AV	35.4	40.6	-1.0	35.5	-	39.5	53.9	14.4	Floor noise

Result = Reading + Ant Factor + Loss (Cable+Attenuator+Filter+Distance factor(above 1 GHz)) - Gain(Amplifier)

*Other frequency noises omitted in this report were not seen or had enough margin (more than 20 dB).

Distance factor: 1 GHz - 10 GHz 20log(4 m / 3.0 m) = 2.5 dB
 10 GHz - 40 GHz 20log(1.0 m / 3.0 m) = -9.5 dB

Radiated Spurious Emission

Report No.	12486805H	
Test place	Ise EMC Lab.	
Semi Anechoic Chamber	No.4	No.1
Date	September 20, 2018	September 25, 2018
Temperature / Humidity	22 deg. C / 53 % RH	24 deg. C / 68 % RH
Engineer	Akihiko Maeda	Takafumi Noguchi
	(1 GHz - 10 GHz)	(10 GHz - 40 GHz)
Mode	Tx 11n-20 5825 MHz	

Polarity	Frequency [MHz]	Detector	Reading [dBuV]	Ant.Fac. [dB/m]	Loss [dB]	Gain [dB]	Duty Factor [dB]	Result [dBuV/m]	Limit [dBuV/m]	Margin [dB]	Remark
Hori	5850.000	PK	39.9	32.2	6.7	31.8	-	47.0	122.2	75.2	
Hori	5855.000	PK	39.8	32.2	6.7	31.8	-	46.9	110.8	63.9	
Hori	5875.000	PK	39.6	32.3	6.7	31.8	-	46.8	105.2	58.4	
Hori	5925.000	PK	40.4	32.3	6.7	31.8	-	47.6	68.2	20.6	
Hori	11650.000	PK	45.4	39.4	-2.2	36.0	-	46.6	73.9	27.3	Floor noise
Hori	17475.000	PK	45.2	42.6	-0.3	35.5	-	52.0	73.9	21.9	Floor noise
Hori	23300.000	PK	45.6	40.5	-1.0	35.5	-	49.6	73.9	24.3	Floor noise
Hori	11650.000	AV	34.6	39.4	-2.2	36.0	-	35.8	53.9	18.1	Floor noise
Hori	17475.000	AV	35.8	42.6	-0.3	35.5	-	42.6	53.9	11.3	Floor noise
Hori	23300.000	AV	35.8	40.5	-1.0	35.5	-	39.8	53.9	14.1	Floor noise
Vert	5850.000	PK	39.8	32.2	6.7	31.8	-	46.9	122.2	75.3	
Vert	5855.000	PK	39.9	32.2	6.7	31.8	-	47.0	110.8	63.8	
Vert	5875.000	PK	39.8	32.3	6.7	31.8	-	47.0	105.2	58.2	
Vert	5925.000	PK	40.3	32.3	6.7	31.8	-	47.5	68.2	20.7	
Vert	11650.000	PK	44.8	39.4	-2.2	36.0	-	46.0	73.9	27.9	Floor noise
Vert	17475.000	PK	44.9	42.6	-0.3	35.5	-	51.7	73.9	22.2	Floor noise
Vert	23300.000	PK	45.8	40.5	-1.0	35.5	-	49.8	73.9	24.1	Floor noise
Vert	11650.000	AV	34.6	39.4	-2.2	36.0	-	35.8	53.9	18.1	Floor noise
Vert	17475.000	AV	36.3	42.6	-0.3	35.5	-	43.1	53.9	10.8	Floor noise
Vert	23300.000	AV	35.9	40.5	-1.0	35.5	-	39.9	53.9	14.0	Floor noise

Result = Reading + Ant Factor + Loss (Cable+Attenuator+Filter+Distance factor(above 1 GHz)) - Gain(Amplifier)

*Other frequency noises omitted in this report were not seen or had enough margin (more than 20 dB).

Distance factor: 1 GHz - 10 GHz 20log(4 m / 3.0 m) = 2.5 dB
 10 GHz - 40 GHz 20log(1.0 m / 3.0 m) = -9.5 dB

Radiated Spurious Emission

Report No.	12486805H
Test place	Ise EMC Lab.
Semi Anechoic Chamber	No.4
Date	September 20, 2018
Temperature / Humidity	22 deg. C / 53 % RH
Engineer	Akihiko Maeda
Mode	Tx 11n-20 5825 MHz

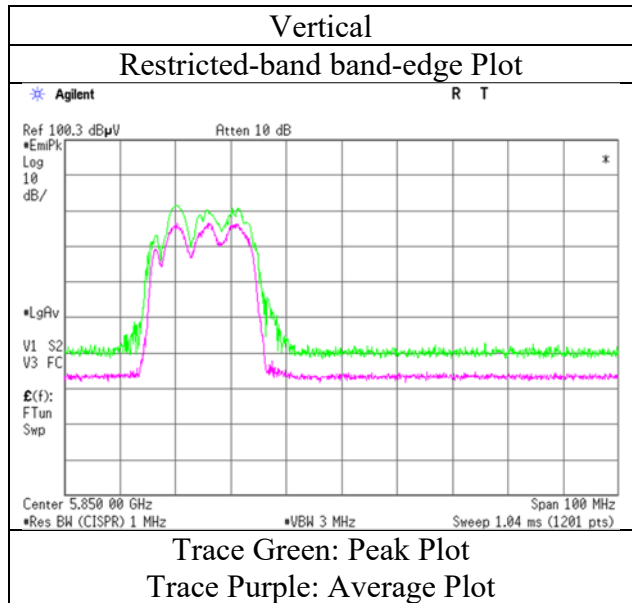
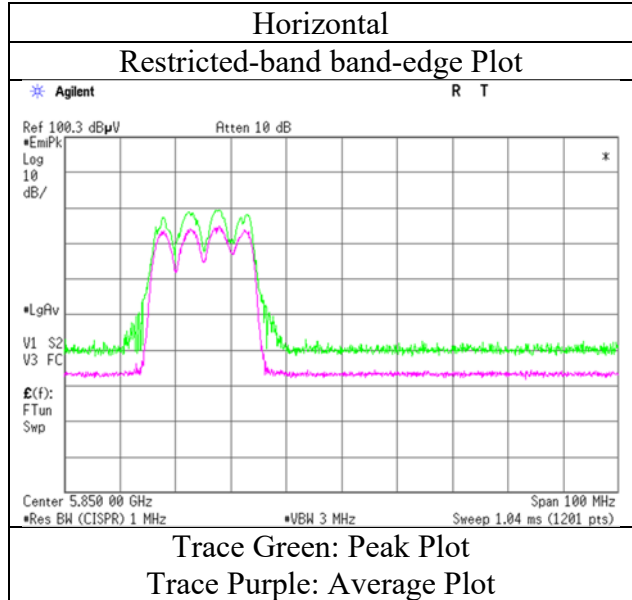

* Final result of restricted band edge was shown in tabular data.

Radiated Spurious Emission

Report No.	12486805H		
Test place	Ise EMC Lab.		
Semi Anechoic Chamber	No.4	No.1	No.1
Date	September 20, 2018	September 25, 2018	September 27, 2018
Temperature / Humidity	22 deg. C / 53 % RH	24 deg. C / 68 % RH	24 deg. C / 68 % RH
Engineer	Akihiko Maeda (1 GHz - 10 GHz)	Takafumi Noguchi (10 GHz - 40 GHz)	Takafumi Noguchi (30 MHz - 1000 MHz)
Mode	Tx 11n-40 5755 MHz		

Polarity	Frequency [MHz]	Detector	Reading [dBuV]	Ant.Fac. [dB/m]	Loss [dB]	Gain [dB]	Duty Factor [dB]	Result [dBuV/m]	Limit [dBuV/m]	Margin [dB]	Remark
Hori	45.985	QP	35.8	12.5	7.7	38.9	-	17.1	40.0	22.9	
Hori	54.571	QP	40.8	9.4	7.8	38.9	-	19.1	40.0	20.9	
Hori	88.560	QP	41.3	7.7	8.4	38.9	-	18.5	43.5	25.0	
Hori	193.473	QP	35.5	16.5	9.7	39.0	-	22.7	43.5	20.8	
Hori	247.883	QP	46.6	11.6	10.2	38.9	-	29.5	46.0	16.5	
Hori	480.000	QP	41.2	17.5	12.0	38.5	-	32.2	46.0	13.8	
Hori	721.805	QP	35.7	20.1	13.7	38.3	-	31.2	46.0	14.8	
Hori	5650.000	PK	41.0	31.9	6.6	31.8	-	47.7	68.2	20.5	
Hori	5700.000	PK	40.2	32.0	6.6	31.8	-	47.0	105.2	58.2	
Hori	5720.000	PK	42.6	32.1	6.6	31.8	-	49.5	110.8	61.3	
Hori	5723.050	PK	39.9	32.1	6.6	31.8	-	46.8	117.8	71.0	
Hori	5725.000	PK	40.0	32.1	6.6	31.8	-	46.9	122.2	75.3	
Hori	11510.000	PK	43.3	39.7	-2.3	36.0	-	44.7	73.9	29.2	Floor noise
Hori	17265.000	PK	46.0	40.9	-0.3	35.6	-	51.0	73.9	22.9	Floor noise
Hori	23020.000	PK	45.6	40.7	-1.0	35.5	-	49.8	73.9	24.1	Floor noise
Hori	11510.000	AV	34.4	39.7	-2.3	36.0	-	35.8	53.9	18.1	Floor noise
Hori	17265.000	AV	35.6	40.9	-0.3	35.6	-	40.6	53.9	13.3	Floor noise
Hori	23020.000	AV	36.0	40.7	-1.0	35.5	-	40.2	53.9	13.7	Floor noise
Vert	45.920	QP	43.4	12.5	7.7	38.9	-	24.7	40.0	15.3	
Vert	88.524	QP	46.7	7.7	8.4	38.9	-	23.9	43.5	19.6	
Vert	105.219	QP	45.0	10.8	8.6	39.0	-	25.4	43.5	18.1	
Vert	268.538	QP	48.1	12.6	10.4	38.9	-	32.2	46.0	13.8	
Vert	337.339	QP	42.3	14.7	11.0	38.7	-	29.3	46.0	16.7	
Vert	480.003	QP	36.9	17.5	12.0	38.5	-	27.9	46.0	18.1	
Vert	5650.000	PK	40.2	31.9	6.6	31.8	-	46.9	68.2	21.3	
Vert	5700.000	PK	39.7	32.0	6.6	31.8	-	46.5	105.2	58.7	
Vert	5720.000	PK	40.2	32.1	6.6	31.8	-	47.1	110.8	63.7	
Vert	5723.050	PK	39.9	32.1	6.6	31.8	-	46.8	117.8	71.0	
Vert	5725.000	PK	40.9	32.1	6.6	31.8	-	47.8	122.2	74.4	
Vert	11510.000	PK	46.3	39.7	-2.3	36.0	-	47.7	73.9	26.2	Floor noise
Vert	17265.000	PK	45.4	40.9	-0.3	35.6	-	50.4	73.9	23.5	Floor noise
Vert	23020.000	PK	45.8	40.7	-1.0	35.5	-	50.0	73.9	23.9	Floor noise
Vert	11510.000	AV	34.5	39.7	-2.3	36.0	-	35.9	53.9	18.0	Floor noise
Vert	17265.000	AV	35.9	40.9	-0.3	35.6	-	40.9	53.9	13.0	Floor noise
Vert	23020.000	AV	36.2	40.7	-1.0	35.5	-	40.4	53.9	13.5	Floor noise

Result = Reading + Ant Factor + Loss (Cable+Attenuator+Filter+Distance factor(above 1 GHz)) - Gain(Amplifier)

*Other frequency noises omitted in this report were not seen or had enough margin (more than 20 dB).

Distance factor: 1 GHz - 10 GHz 20log(4 m / 3.0 m) = 2.5 dB
 10 GHz - 40 GHz 20log(1.0 m / 3.0 m) = -9.5 dB

Radiated Spurious Emission

Report No.	12486805H
Test place	Ise EMC Lab.
Semi Anechoic Chamber	No.4
Date	September 20, 2018
Temperature / Humidity	22 deg. C / 53 % RH
Engineer	Akihiko Maeda
Mode	Tx 11n-40 5755 MHz

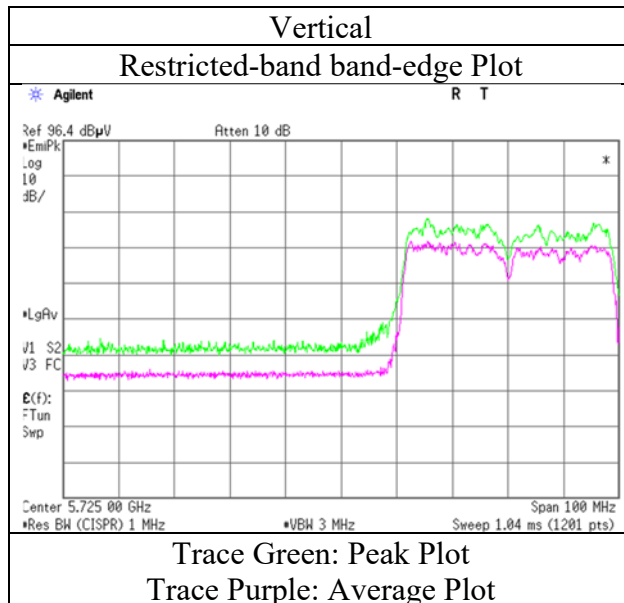
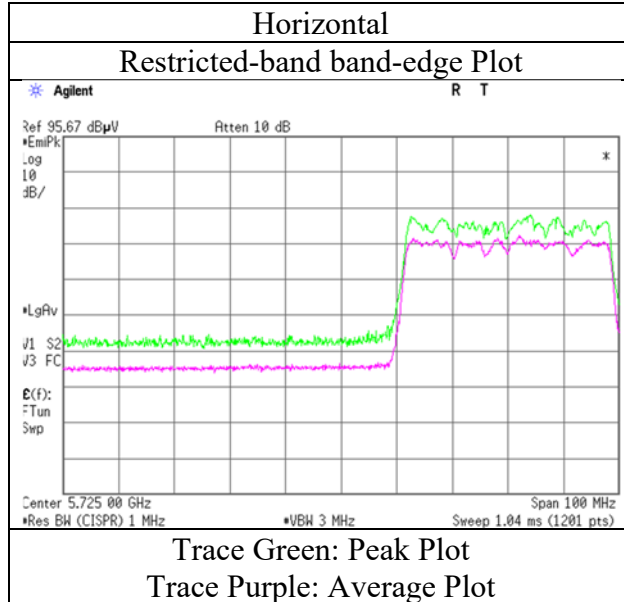

* Final result of restricted band edge was shown in tabular data.

UL Japan, Inc.

Ise EMC Lab.

4383-326 Asama-cho, Ise-shi, Mie-ken 516-0021 JAPAN

Telephone : +81 596 24 8999

Facsimile : +81 596 24 8124

Radiated Spurious Emission

Report No.	12486805H
Test place	Ise EMC Lab.
Semi Anechoic Chamber	No.4
Date	September 20, 2018
Temperature / Humidity	22 deg. C / 53 % RH
Engineer	Akihiko Maeda
Mode	Tx 11n-40 5795 MHz

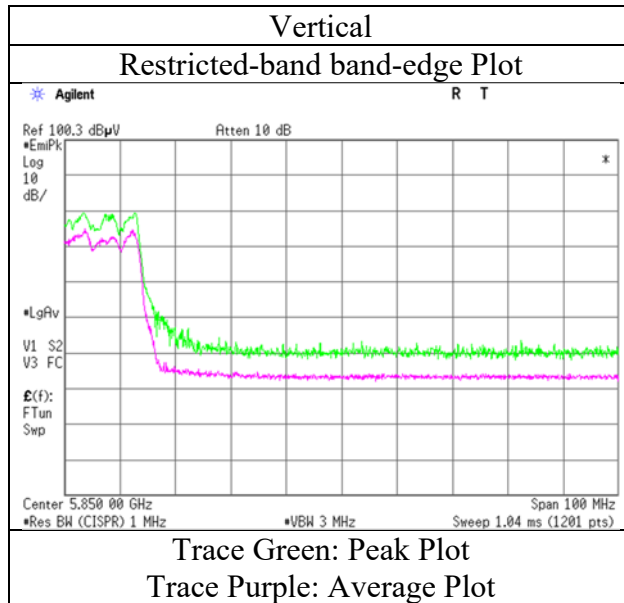
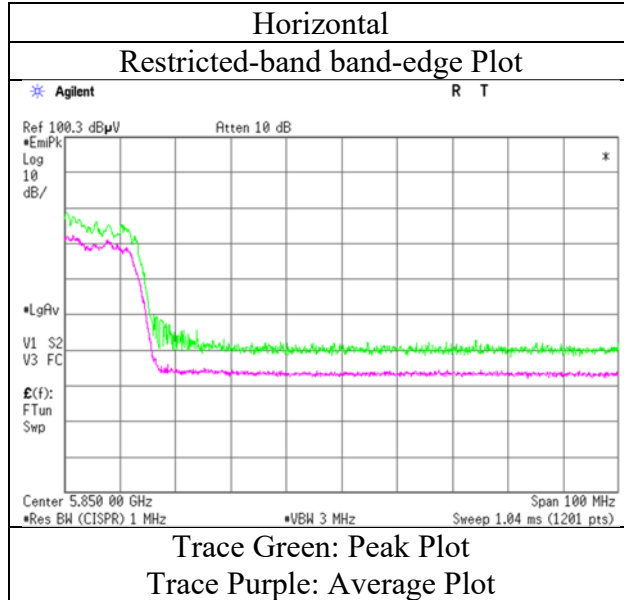

* Final result of restricted band edge was shown in tabular data.

UL Japan, Inc.

Ise EMC Lab.

4383-326 Asama-cho, Ise-shi, Mie-ken 516-0021 JAPAN

Telephone : +81 596 24 8999

Facsimile : +81 596 24 8124

Radiated Spurious Emission (Plot data, Worst case)

Report No.	12486805H		
Test place	Ise EMC Lab.		
Semi Anechoic Chamber	No.4	No.1	No.1
Date	September 20, 2018	September 25, 2018	September 27, 2018
Temperature / Humidity	22 deg. C / 53 % RH	24 deg. C / 68 % RH	24 deg. C / 68 % RH
Engineer	Akihiko Maeda (1 GHz - 10 GHz)	Takafumi Noguchi (10 GHz - 40 GHz)	Takafumi Noguchi (30 MHz - 1000 MHz)
Mode	Tx 11n-40 5755 MHz		

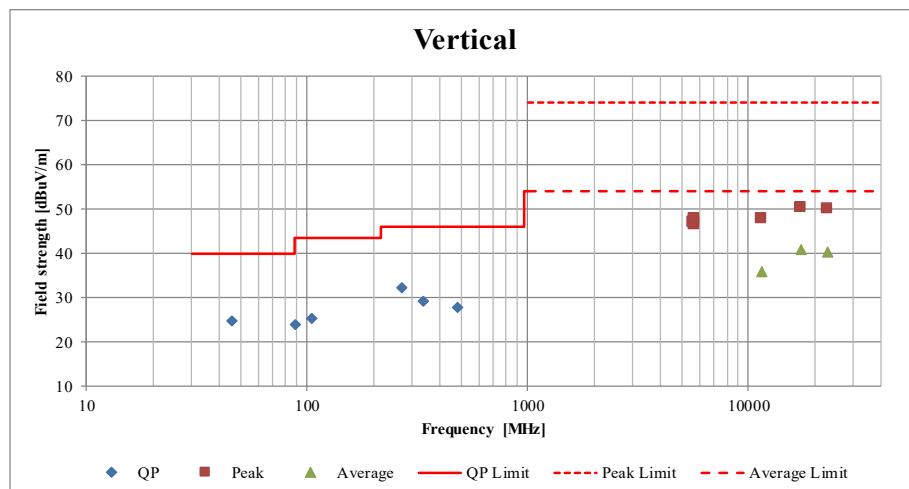
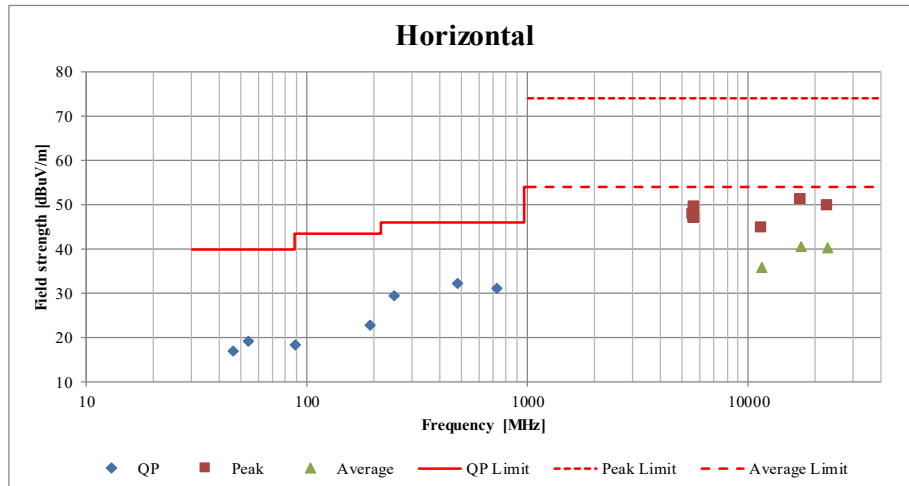

*These plots data contains sufficient number to show the trend of characteristic features for EUT.

APPENDIX 2: Test instruments

Test Instruments

Test Item	LIMS ID	Description	Manufacturer	Model	Serial	Last Calibration Date	Calibration Due Date	Cal Int
RE	141226	Microwave Cable	Junkosha	MMX221-00500DMSD MS	1502S304	03/12/2018	03/31/2019	12
RE	141293	High Pass Filter 7-20GHz	TOKIMEC	TF37NCCB	602	01/18/2018	01/31/2019	12
RE	141393	Microwave Cable	Junkosha	MWX221	1604S254(1 m) / 1608S088(5 m)	08/08/2018	08/31/2019	12
RE	141511	Horn Antenna 1-18GHz	Schwarzbeck	BBHA9120D	253	06/04/2018	06/30/2019	12
RE	141576	Pre Amplifier	AGILENT	8449B	3008A01671	02/16/2018	02/28/2019	12
RE	141885	Spectrum Analyzer	AGILENT	E4448A	US44300523	11/14/2017	11/30/2018	12
RE	141588	Pre Amplifier	MITEQ, Inc	AMF-6F-2600400-33-8P / AMF-4F-2600	1871355 / 1871328	09/21/2018	09/30/2019	12
RE	142226	Measure	KOMELON	KMC-36	-	-	-	-
RE	160324	Coaxial Cable	Huber+Suhner	SUCOFLEX 102A	MY009/2A	11/08/2017	11/30/2018	12
RE	141517	Horn Antenna 26.5-40GHz	ETS LINDGREN	3160-10	152399	06/08/2018	06/30/2019	12
RE	141530	Digital Tester	Fluke Corporation	FLUKE 26-3	78030621	08/21/2018	08/31/2019	12
RE	141566	Thermo-Hygrometer	CUSTOM	CTH-201	A08Q26	01/24/2018	01/31/2019	12
RE	141503	Horn Antenna 18-26.5GHz	EMCO	3160-09	1265	06/06/2018	06/30/2019	12

*Hyphens for Last Calibration Date, Calibration Due Date and Cal Int (month) are instruments that Calibration is not required (e.g. software), or instruments checked in advance before use.

The expiration date of the calibration is the end of the expired month.

All equipment is calibrated with valid calibrations. Each measurement data is traceable to the national or international standards.

As for some calibrations performed after the tested dates, those test equipment have been controlled by means of an unbroken chains of calibrations.

Test item:

RE: Radiated Emission

UL Japan, Inc.

Ise EMC Lab.

4383-326 Asama-cho, Ise-shi, Mie-ken 516-0021 JAPAN

Telephone : +81 596 24 8999

Facsimile : +81 596 24 8124