

Panasonic[®]

Operating Instructions

Section 1 : Before Use

Network Recorder

Model No.

WJ-VPU4000

For professional use only

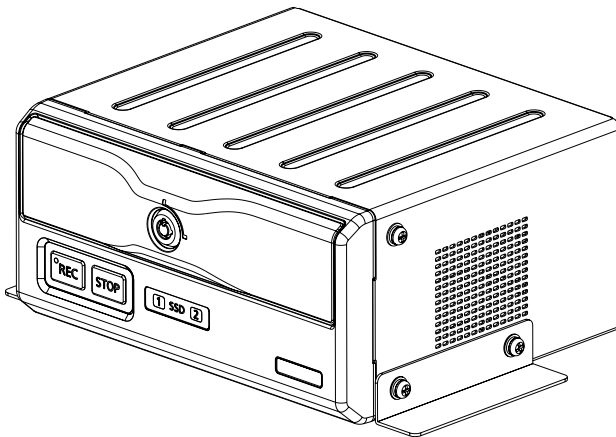

Manuals for this recorder are prepared in two parts.

Section 1 : Before Use (this manual)

Section 2 : Operation (for operating procedures, functions, etc.)
(PDF)

Before operating this product, please read the instructions carefully and save this manual for future use.

Contents

Read this first!.....	3	Before Use	16
IMPORTANT SAFETY		Notes on Handling.....	19
INSTRUCTIONS	11	Control Reference Guide	20
Functions of This Recorder	12	Connections.....	26
Included Accessories.....	13	SSD Insertion and Removal.....	28
Other Necessary Items (not included)	13	Turning the Recorder On and Off..	30
Options	13	On.....	30
About Manuals of This Recorder ..	14	Off.....	30
Open Source Software.....	14	Connector Signals.....	31
Limitation of liability	14	Troubleshooting.....	33
Disclaimer of warranty.....	15	Specifications	34
Trademarks and registered trademarks.....	15		

Read this first!

WARNING:

- To prevent fire or electric shock hazard, do not expose this apparatus to rain or moisture.
- The installation shall be carried out in accordance with all applicable installation rules.
- This product has no power switch. When turning off the power, turn off a Power Supply or remove a power cable.
- Stop operation immediately in case of abnormal operation. If the product emits smoke, smells of smoke, or shows signs of external deformation, continued use may lead to fire or other failure, resulting in injury or damage to the product. Turn the power off immediately and contact qualified service personnel for service.

CAUTION:

- This product has no power switch. Be sure to install disconnect devices such as a circuit breaker to shut down the main power of power supplying equipment to this product.
- In order to maintain adequate ventilation, do not install or place this unit in a book case, built-in cabinet or any other confined space. To prevent risk of electric shock or fire hazard due to overheating, ensure that curtains and any other materials do not obstruct the ventilation. Provide at least the space indicated by the width of the brackets on each side of the ventilation vents when installing the recorder. Do not install the recorder so that the ventilation vents are located downwards.
- To reduce the risk of fire or electric shock and annoying interference, use the recommended accessories only.
- To reduce the risk of fire, the red (BATT) and white (SIGNAL) wires of the power cable must be connected via fuses (10 A).
- Before attempting to connect or operate this product, please read the label on the bottom.
- Before attempting to connect or operate this product, please read these instructions carefully.
- The DC power supply connected to this recorder must be in the same building.
- This recorder is only intended for a connection to an ethernet or PoE network without routing to the outside plant.

 indicates safety information.

Read this first! (continued)

- Shielded (STP) LAN cables must be used with this unit to ensure compliance with EMC standards.
- This recorder is designed for use and installation in a vehicle.
For example, it may be mounted on the center console or in the trunk.
- The installation of this equipment must only be performed by a professional installer.
- For information about screws and other parts required for installation, refer to the corresponding section of this document.
- The rating plate is on the underside of the unit.

For U.S.A.

FCC Caution:

Changes or modifications not expressly approved by the party responsible for compliance could void the user's authority to operate the equipment.

Supplier's Declaration of conformity

Trade name: Panasonic

Model No.: WJ-VPU4000

Responsible Party: Panasonic Corporation of North America

Two Riverfront Plaza, Newark, New Jersey 07102-5490

Support Contact: 1-800-528-6747



FCC Note:

This equipment has been tested and found to comply with the limits for a class A digital device, pursuant to Part 15 of the FCC Rules.

These limits are designed to provide reasonable protection against harmful interference when the equipment is operated in a commercial environment.

This equipment generates, uses, and can radiate radio frequency energy, and if not installed and used in accordance with the instruction manual, may cause harmful interference to radio communications. Operation of this equipment in a residential area is likely to cause harmful interference in which case the user will be required to correct the interference at his own expense.

Warning:

To assure continued FCC emission limit compliance, the user must only use shielded interface cables when connecting to external units. Also, any unauthorized changes or modifications to this equipment could void the user's authority to operate it.

For Canada

CAN ICES-3(A)/NMB-3(A)

Read this first! (continued)

AVERTISSEMENT:

- Afin d'éviter tout risque de déclaration d'incendie ou d'électrocution, ne pas exposer cet appareil à la pluie ni à l'humidité.
- L'installation doit être effectuée conformément à toutes les règles d'installation en vigueur.
- Ce produit ne dispose pas d'un interrupteur d'alimentation. Une fois l'appareil hors tension, éteindre la source d'alimentation ou retirer le câble d'alimentation.
- Arrêtez immédiatement d'utiliser le produit en cas de fonctionnement anormal.

Si le produit émet de la fumée, des odeurs de fumée ou montre des signes de déformation externe, une utilisation prolongée pourrait entraîner un incendie ou d'autres défaillances, et causer ainsi des blessures ou endommager le produit.

Mettez immédiatement le produit hors tension et prenez contact avec un technicien qualifié pour le dépannage.

ATTENTION:

- Ce produit ne possède aucun interrupteur d'alimentation. Assurez-vous d'installer des dis-positifs de déconnexion tel qu'un disjoncteur pour couper la puissance principale des équipements d'alimentation à ce produit.
- Afin de maintenir une aération appropriée, ne pas installer pas ni placer cet appareil dans une bibliothèque, un placard ou tout autre espace réduit.
Afin de prévenir le risque de choc électrique ou d'incendie dû à la surchauffe, veiller à ce que les rideaux ou autres matériaux n'obstruent pas l'aération.
Prévoir au moins l'espace indiqué par la largeur des supports sur les côtés des orifices d'aération lors de l'installation de l'enregistreur. Ne pas installer l'enregistreur avec les orifices d'aération vers le bas.
- Afin de réduire le risque d'incendie, de choc électrique et d'interférence, n'utiliser que les accessoires recommandés.
- Afin de réduire le risque d'incendie, les fils rouge (BATT) et blanc (SIGNAL) du câble d'alimentation doivent être raccordés par les fusibles (10 A).
- Avant d'effectuer le branchement ou de mettre cet appareil en service, veuillez lire les instructions de l'étiquette collée dessous.
- Nous vous recommandons de lire attentivement ces instructions avant de raccorder ou d'utiliser cet appareil.
- L'alimentation CC connectée à cet enregistreur doit se trouver dans le même bâtiment.
- Cet enregistreur est uniquement destiné à une connexion à un réseau Ethernet ou PoE sans acheminement vers l'installation extérieure.

 indique les informations concernant la sécurité.

Read this first! (continued)

- Des câbles blindés LAN (STP) doivent être utilisés avec cet appareil pour assurer la conformité aux normes CEM.
- Cet enregistreur est destiné à un usage et à une installation dans un véhicule. Par exemple, il peut se monter sur une console centrale ou dans un coffre.
- L'installation de cet appareil ne peut être effectuée que par un technicien qualifié.
- Pour plus d'informations sur les vis et les autres pièces requises pour l'installation, reportez-vous à la section correspondante de ce document.
- La plaque signalétique se trouve sur la partie inférieure de cet appareil.

Pour le Canada

CAN ICES-3(A)/NMB-3(A)

• Vis de fixation

Méthode d'installation	Vis recommandée *1	La capacité de traction minimale requise *2
Quand l'enregistreur est installé sur un plancher du coffre.	M4 x 16 mm *3 {5/8 pouces} / 4 él.	196 N {44 lbf}

*1 Choisissez les vis en fonction du matériau de l'endroit où de l'enregistreur sera montée. Les vis et les clous à bois ne doivent pas être utilisés dans ce cas.

*2 Cette valeur indique la capacité de traction minimale requise par vis.

*3 La longueur des vis est un exemple pour l'installation de l'enregistreur sur un plancher de coffre robuste d'une épaisseur de 20 mm {25/32 pouces} ou plus.

Read this first! (continued)

For U.S.A.

<FCC Information>

The following regulatory and safety notices must be published in documentation supplied to the end user of the product or system incorporating an adapter in compliance with local regulations.

This transmitter must not be co-located or operated in conjunction with any other antenna or transmitter.

Operating near 2.4 GHz electrical appliances may cause interference. Move away from the electrical appliances.

Compliance with FCC requirement 15.407(c)

Data transmission is always initiated by software, which is then passed down through the MAC, through the digital and analog baseband, and finally to the RF chip. Several special packets are initiated by the MAC. These are the only ways the digital baseband portion will turn on the RF transmitter, which it then turns off at the end of the packet. Therefore, the transmitter will be on only while one of the aforementioned packets is being transmitted. In other words, this device automatically discontinues transmission in case of either absence of information to transmit or operational failure.

Frequency Tolerance: ± 20 ppm (2.4GHz band), ± 20 ppm (5GHz band)

Radio Frequency (RF) Exposure Warning

This equipment complies with FCC radiation exposure limits set forth for an uncontrolled environment and meets the FCC radio frequency (RF) Exposure Guidelines. This equipment should be installed and operated keeping the radiator at least 20cm or more away from person's body.

This [WJ-VPU4000] has been tested and meets the FCC RF exposure guidelines when used with the [Panorama Antennas Ltd] accessories supplied or designated for this product. Use of other accessories may not ensure compliance with FCC RF exposure guidelines.

FCC RF Exposure Warning

To comply with FCC RF exposure requirements in uncontrolled environment:
– This equipment must be installed and operated in accordance with provided instructions and a minimum 20 cm (8 inches) spacing must be provided between antenna and all person's body (excluding extremities of hands, wrists, feet and ankles) during wireless modes of operation.

Read this first! (continued)

For Canada

<IC Information>

The following regulatory and safety notices must be published in documentation supplied to the end user of the product or system incorporating an adapter in compliance with local regulations.

Informations à fournir à l'utilisateur final par l'installateur ou l'intégrateur

Les consignes de contrôle et de sécurité suivantes doivent être publiées dans la documentation fournie à l'utilisateur final du produit ou du système intégrant un adaptateur conformément aux règlements locaux.

This device contains licence-exempt transmitter(s)/receiver(s) that comply with Innovation, Science and Economic Development Canada's licence-exempt RSS(s). Operation is subject to the following two conditions:

1. This device may not cause interference.
2. This device must accept any interference, including interference that may cause undesired operation of the device.

L'émetteur/récepteur exempt de licence contenu dans le présent appareil est conforme aux CNR d'Innovation, Sciences et Développement économique Canada applicables aux appareils radio exempts de licence. L'exploitation est autorisée aux deux conditions suivantes:

1. L'appareil ne doit pas produire de brouillage;
2. L'appareil doit accepter tout brouillage radioélectrique subi, même si le brouillage est susceptible d'en compromettre le fonctionnement.

This radio transmitter (216A-WJVP4000) has been approved by Innovation, Science and Economic Development Canada to operate with the antenna types listed below, with the maximum permissible gain indicated. Antenna types not included in this list that have a gain greater than the maximum gain indicated for any type listed are strictly prohibited for use with this device.

Antenna type	Gain	Impedance
Sharkfin Antenna	2.5 dBi	50 Ohms

Le présent émetteur radio (216A-WJVP4000) a été approuvé par Innovation, Sciences et Développement économique Canada pour fonctionner avec les types d'antenne énumérés ci-dessous et ayant un gain admissible maximal. Les types d'antenne non inclus dans cette liste, et dont le gain est supérieur au gain maximal indiqué pour tout type figurant sur la liste, sont strictement interdits pour l'exploitation de l'émetteur.

Type d'antenne	Gain	l'impédance
Sharkfin Antenna	2.5 dBi	50 Ohms

Read this first! (continued)

For Canada

<IC Information>

Radio Frequency (RF) Exposure Warning

This equipment complies with ISED radiation exposure limits set forth for an uncontrolled environment and meets RSS-102 of the ISED radio frequency (RF) Exposure rules. This equipment should be installed and operated keeping the radiator at least 20cm or more away from person's body.

Cet équipement est conforme aux limites d'exposition aux rayonnements énoncés pour un environnement non contrôlé et respecte les règles d'exposition aux fréquences radioélectriques (RF) CNR-102 de l'ISDE. Cet équipement doit être installé et utilisé en gardant une distance de 20 cm ou plus entre le radiateur et le corps humain.

This WJ-VPU4000 has been tested and meets the ISED RF exposure rules when used with the Panorama Antennas Ltd accessories supplied or designated for this product. Use of other accessories may not ensure compliance with ISED RF exposure rules.

Ce WJ-VPU4000 a été testé et est conforme aux règles d'exposition aux fréquences radioélectriques (RF) de l'ISDE lorsqu'il est utilisé avec les accessoires Antennas Ltd fournis ou conçus pour ce produit. L'usage d'autres accessoires ne garantit pas nécessairement la conformité aux règles d'exposition aux RF de l'ISDE.

Data transmission is always initiated by software, which is then passed down through the MAC, through the digital and analog baseband, and finally to the RF chip. Several special packets are initiated by the MAC. These are the only ways the digital baseband portion will turn on the RF transmitter, which it then turns off at the end of the packet. Therefore, the transmitter will be on only while one of the aforementioned packets is being transmitted. In other words, this device automatically discontinues transmission in case of either absence of information to transmit or operational failure.

La transmission des données est toujours initiée par le logiciel, puis les données sont transmises par l'intermédiaire du MAC, par la bande de base numérique et analogique et, enfin, à la puce RF. Plusieurs paquets spéciaux sont initiés par le MAC. Ce sont les seuls moyens pour qu'une partie de la bande de base numérique active l'émetteur RF, puis désactive celui-ci à la fin du paquet. En conséquence, l'émetteur reste uniquement activé lors de la transmission d'un des paquets susmentionnés. En d'autres termes, ce dispositif interrompt automatiquement toute transmission en cas d'absence d'information à transmettre ou de défaillance.

Read this first! (continued)

Mandatory Safety Precautions for Installation

WARNING:

To reduce the risk of fire or damage to the product, be sure to follow the instructions below.

- Read the operating instructions of this product and optional equipment carefully.
- Read all safety instructions provided by the automaker before installation.
- Before connecting, disconnect the power cable (included in the Cable Kit sold separately) from the unit.
- Disconnect a minus battery lead wire from the battery terminals before installing and connecting the product.
- After all other connections are complete, make sure to properly connect the power cable.
- The red (BATT) and white (SIGNAL) wires of the power cable (included in the Cable Kit sold separately) must be connected via fuses (10 A).
- Do not use the power cable (included in the Cable Kit sold separately) with the engine compartment.
- The product, accessories and wiring must not be installed in locations where they impede airbag operation.
- Do not use bolts and nuts that secure safety devices (such as the steering, brake system and the fuel tank) for product installation and ground cable connection.
- Make sure that all unused wires are properly insulated so that no bare wire ends can come into contact with metal car parts.
- All wiring must be bundled together and properly secured to prevent entanglement with the steering wheel, shift lever, brake pedal and the feet of occupants. Loose wires may otherwise create an obstacle in entering and leaving the vehicle and pose a threat to safe driving.
- After completing installation and wiring, make sure that all automotive electric components (such as brakes, lights, the horn, hazard lights and direction indicators) work normally.
- Install the wireless LAN antennas where they will be at least 20 cm away from people at all times.

CAUTION:

- All wiring, installation and removal work require technical expertise and experience, and must be performed by authorized personnel.
- Use only the supplied accessories and designated parts. Failure to do so may result in fire or other hazard.
- To prevent risk of fire hazard due to overheating, do not obstruct the ventilation.

IMPORTANT SAFETY INSTRUCTIONS

This product is a professional equipment.

This product is not suitable for use in locations where children are likely to be present.

The power supply cord is used as the main disconnect device, ensure that the socket-outlet is located/installed near the equipment and is easily accessible.

Only use attachments/accessories specified by the manufacturer.

Refer all servicing to qualified service personnel. Servicing is required when the apparatus has been damaged in any way, such as power-supply cord or plug is damaged, liquid has been spilled or objects have fallen into the apparatus, the apparatus has been exposed to rain or moisture, does not operate normally, or has been dropped.

For U.S.A

The model number and serial number of this product may be found on the surface of the unit.

You should note the model number and serial number of this unit in the space provided and retain this book as a permanent record of your purchase to aid identification in the event of theft.

Model No. _____

Serial No. _____

Notice (U.S.A. only):

Disposal may be regulated in your community due to environmental considerations.

For disposal or recycling information, please visit Panasonic website:

<https://www.panasonic.com/us/corporate/sustainability.html> or
call 1-888-769-0149.

Functions of This Recorder

The WJ-VPU4000 is a video recorder using an SSD (Solid State Drive). Separately sold network cameras, and a trigger cable can be connected to the recorder, as can off-the-shelf radar guns and microphones. The recorder can be controlled using software installed on a personal computer.

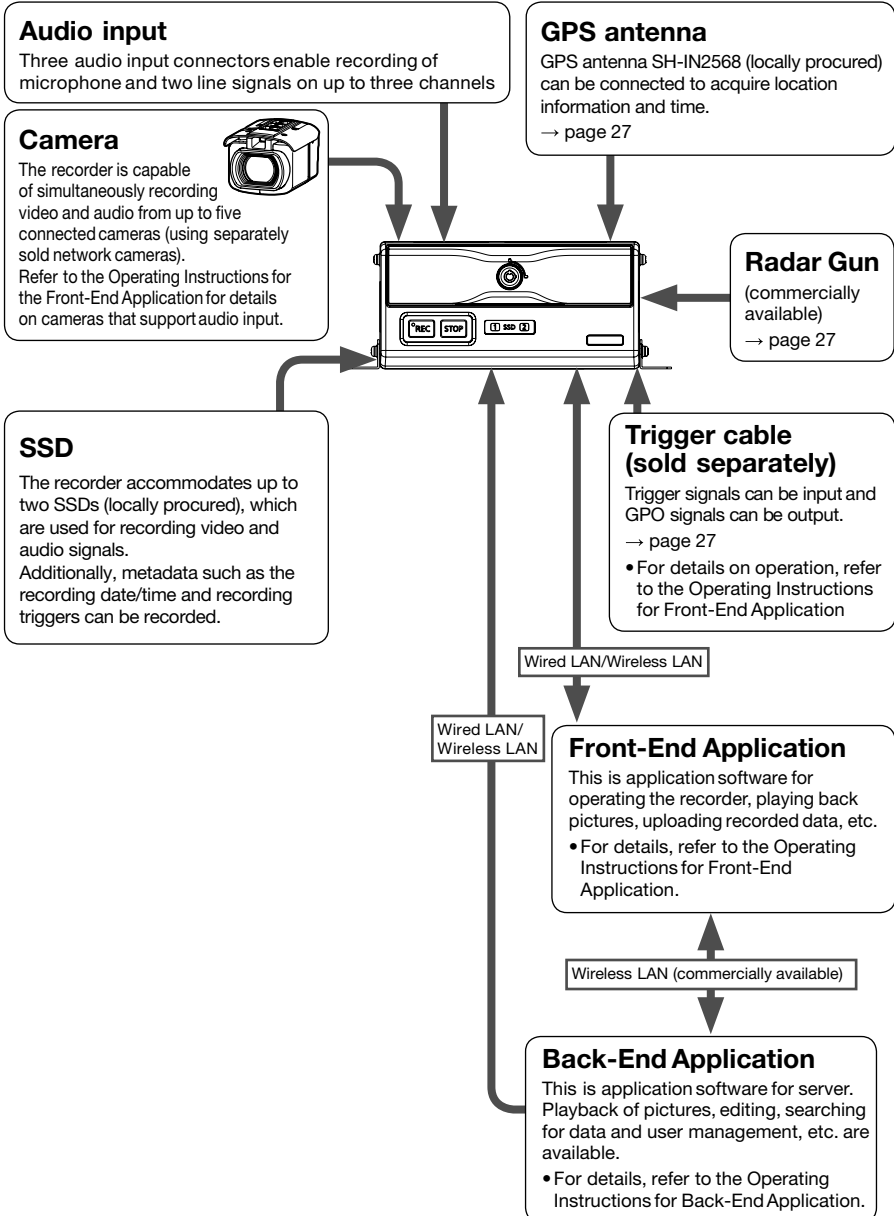

Included Accessories

Warranty card	1	Open Source Software license booklet.....	1
Operating Instructions"Section 1" (this document).....	1	Key	2

Other Necessary Items (not included)

• Fixing screw

Installation method	Recommended screw ^{*1}	Minimum pull-out strength ^{*2}
Mount the recorder on a trunk floor.	M4 × 16 mm ^{*3} {5/8 inches} × 4 pcs.	196 N {44 lbf}

- *1 Select screws according to the material of the location that the recorder will be mounted to. In this case, wood screws and nails should not be used.
- *2 This value indicates the minimum pull-out strength required value per screw.
- *3 The screw length is an example when installing the recorder on a robust trunk floor with a thickness of 20mm {25/32 inches} or more.

Options

- Network Camera (WV-VC30, WV-VC35)
Front Camera
 - Network Camera (WV-VC31)
Back Seat Camera (Rear Seat Camera)
 - Network Camera (WV-VC32)
Side Camera
 - Pairing Dock
(WV-TW37004A/WV-TW37004)
For Body Worn Camera (WV-TW370)
 - PC Applications
Front-End Application
Back-End Application
 - Antenna
(SH-IN2568/SH-IN2568-W, locally procured)
Multiple antenna for WLAN × 2
Bluetooth, GPS
- Note:**
You can connect Panasonic network cameras.
Refer to the Operating Instructions for the Front-End Application for details on supported models.
- Cable Kit (WJ-VR3001)
Power cable
Trigger cable
 - Single Dock Charger
(WV-BWC40D1A/WV-BWC40D1)
For Body Worn Camera
(WV-BWC4000)
- Note:**
• Part No. of different colors (Electrical data other than color is the same)
SH-IN2568 (Body Color: Black)
SH-IN2568-W (Body Color: White)
• In this manual, SH-IN2568 and SH-IN2568-W are referred to as SH-IN2568.

About Manuals of This Recorder

Manuals for this recorder are prepared in two parts:

Section 1: Before Use (this manual)

Section 2: Operation (for operating procedures, functions, etc.) (PDF)

Ask the supplier for information on how to obtain "Section 2: Operation."

LEDs described as lamps or indicators in the operating manual of network cameras are described as lamps in this manual.

■ Definition of terms

Officer: anybody using the Front-End Application, or Back-End Application to control the recorder

Administrator: a user with administrator privileges to collect and manage Network Recorder data

■ Figures in this manual

Figures for this recorder may differ from the actual product.

Open Source Software

- This product contains open source software licensed under GPL (GNU General Public License), LGPL (GNU Lesser General Public License), etc.
- Customers can duplicate, distribute and modify the source code of the software under license of GPL and/or LGPL.
- For details concerning licensing and source code of open source software, refer to the included booklet "Open Source Software".
- Please note that we shall not respond to any inquiries regarding the contents of the source code.

Limitation of liability

THIS PUBLICATION IS PROVIDED "AS IS" WITHOUT WARRANTY OF ANY KIND, EITHER EXPRESS OR IMPLIED, INCLUDING BUT NOT LIMITED TO, THE IMPLIED WARRANTIES OF MERCHANTABILITY, FITNESS FOR ANY PARTICULAR PURPOSE, OR NON-INFRINGEMENT OF THE THIRD PARTY'S RIGHT. THIS PUBLICATION COULD INCLUDE TECHNICAL INACCURACIES OR TYPOGRAPHICAL ERRORS. CHANGES ARE ADDED TO THE INFORMATION HEREIN, AT ANY TIME, FOR THE IMPROVEMENTS OF THIS PUBLICATION AND/OR THE CORRESPONDING PRODUCT(S).

Disclaimer of warranty

IN NO EVENT SHALL Panasonic i-PRO Sensing Solutions Co., Ltd. BE LIABLE TO ANY PARTY OR ANY PERSON, EXCEPT FOR REPLACEMENT OR REASONABLE MAINTENANCE OF THE PRODUCT, FOR THE CASES, INCLUDING BUT NOT LIMITED TO BELOW:

- (1) ANY DAMAGE AND LOSS, INCLUDING WITHOUT LIMITATION, DIRECT OR INDIRECT, SPECIAL, CONSEQUENTIAL OR EXEMPLARY, ARISING OUT OF OR RELATING TO THE PRODUCT;
- (2) PERSONAL INJURY OR ANY DAMAGE CAUSED BY INAPPROPRIATE USE OR NEGLIGENT OPERATION OF THE USER;
- (3) UNAUTHORIZED DISASSEMBLE, REPAIR OR MODIFICATION OF THE PRODUCT BY THE USER;
- (4) INCONVENIENCE OR ANY LOSS ARISING WHEN IMAGES ARE NOT DISPLAYED, DUE TO ANY REASON OR CAUSE INCLUDING ANY FAILURE OR PROBLEM OF THE PRODUCT;
- (5) ANY PROBLEM, CONSEQUENTIAL INCONVENIENCE, OR LOSS OR DAMAGE, ARISING OUT OF THE SYSTEM COMBINED BY THE DEVICES OF THIRD PARTY;
- (6) ANY CLAIM OR ACTION FOR DAMAGES, BROUGHT BY ANY PERSON OR ORGANIZATION BEING A PHOTOGENIC SUBJECT, DUE TO VIOLATION OF PRIVACY WITH THE RESULT OF THAT SURVEILLANCE-CAMERA' s PICTURE, INCLUDING SAVED DATA, FOR SOME REASON, BECOMES PUBLIC OR IS USED FOR ANY PURPOSE;
- (7) LOSS OF REGISTERED DATA CAUSED BY ANY FAILURE.

Trademarks and registered trademarks

- The Bluetooth word mark and logos are registered trademarks owned by Bluetooth SIG, Inc. and any use of such marks by Panasonic i-PRO sensing solutions Co., Ltd. is under license.
- All other trademarks identified herein are the property of their respective owners.

Before Use

■ Always perform a test recording.

Before making important recordings, always perform a test recording to confirm that recording works as expected. Especially when using “Changing the image mode” or “Night Shooting with the IR Function”, verify that your settings produce the desired results.

■ When using for the first time or when using in a place with a different time zone, set the correct time zone.

The factory default time zone setting is “Eastern DST”.

When using in a different time zone, set the time zone for that region (refer to the Operating Instructions for Front-End Application).

■ Entering officer/user information on this unit allows you to find out the person performed recording later

(refer to the Operating Instructions for Front-End Application).

■ This recorder is designed for use with other specified accessories , options (sold separately) and antenna (locally procured).

■ This unit can be managed by application software running on a PC (referred to as the PC application in this manual).

- For details on how to run the PC application, see the Operating Instructions of the PC application.

■ Do not turn the power off while recording.

Be sure to stop all operations before disconnecting power (refer to “Stopping Recording” in Section 2: Operation).

Disconnecting power especially during access (for example, during recording) may damage the SSD or corrupt file management data, settings information and other data on the SSD. If file corruption occurs involving file management data, the drive should be reformatted. For details on reformatting, refer to the Operating Instructions for Front-End Application or contact your supplier.

- In no event will Panasonic i-PRO sensing solutions Co., Ltd. be liable for any damages, including any incidental or consequential damages, stemming from a failure to record data or from lost settings or data. Any of the following actions can result in problems:
 - Power supply to the recorder is interrupted or impaired during recording, for example by starting an engine.

Before Use (continued)

■ About the Internal Clock

Confirming the Time

The internal clock is set at the time of factory default. Check the time before using, and reset the clock if necessary. (Refer to the Operating Instructions for Front-End Application)

Note:

To use GPS, connect the GPS antenna SH-IN2568 (locally procured) to the [GPS ANT.] connector on the rear panel.

Consult your supplier and request connection.

During GPS reception, the signals received will regularly and automatically set the recorder clock to GPS time.

■ Product Disposal/Transfer.

Video, Audio and images saved on the SSD may lead to personal information leakage.

When it is necessary to dispose or give this product to someone, even when for repair, make sure that all evidence has been removed from the recorder and the PC installed with the Front-End or Back-End Application (refer to the Operating Instructions for Front-End Application to clear user information in the recorder).

■ Network Security

In order to reduce the occurrence of the security problem, make sure to set up the security-relating functions before using Internet Connection. For details, refer to the Operating Instructions for Front-End Application or Back-End Application.

As you will use this unit connected to a network, your attention is called to the following security risks.

- ① Leakage or theft of information through this unit
- ② Use of this unit for illegal operations by persons with malicious intent
- ③ Interference with or stoppage of this unit by persons with malicious intent

It is your responsibility to take precautions such as those described below to protect yourself against the above network security risks.

- Use this unit in a network secured by a firewall, etc.
- If this unit is connected to a network that includes PCs, make sure that the system is not infected by computer viruses or other malicious entities (using a regularly updated anti-virus program, antispyware program, etc.)
- Protect your network against unauthorized access by restricting users to those who log in with an authorized user name and password (refer to the Operating Instructions for Front-End Application).
- Apply measures such as user authentication to protect your network against leakage or theft of information, including image data and authentication information (user names and passwords).

Before Use (continued)

- After the unit is accessed by the administrator, make sure to close the browser for added security (refer to the Operating Instructions for Front-End Application).
- Change the administrator password periodically for added security.
- Do not install the recorder and the PC in locations where the recorder, the PC or the cables can be destroyed or damaged by persons with malicious intent.

■ Security alert when using Wireless LAN products

Wireless LAN provides with an advantage of freely connecting to the network as long as you are in the reach of radio waves.

On the other hand, the radio wave reaches everywhere in the range regardless of obstacles such as walls. Therefore, if security measure is not taken, the following problems may occur:

Communication content may be compromised

A malicious third party may attempt to intercept the radio wave and steal your ID, password, transmitting images, etc.

Breaking into a system

A malicious third party may access your network without authorization and attempt the following:

- Stealing personal and confidential information (Information leakage)
- Impersonating a specific user, communicating and spreading false information (Impersonation)

- Re-writing the intercepted communication content (Falsification)
- Sending computer viruses to corrupt data or the system (Corruption)

In general, Wireless LAN is equipped with the security-related functions to avoid the above threats.

Therefore, enabling the security functions will reduce the possibility of occurrence of the above.

In order to reduce the occurrence of the security problem, make sure to set up the security-relating functions before using the Wireless LAN product.

Due to the specification of Wireless LAN, note that there is a possibility of the security function being compromised by a special manner.

In regard to the security-related settings, please contact your dealer, if necessary.

We would like you to fully understand the risks of using a Wireless LAN product without taking precautions for security, and we recommend you take your own preventative measures upon your own judgment and responsibilities.

If security-related problem occurs due to negligence of security measures or the inevitable reasons caused by the specifications of Wireless LAN, we shall not take any responsibility for the damages that are caused thereby.

Notes on Handling

■ Usage

- Do not set liquid containers or small metal objects on the recorder or SSDs.
- Do not insert foreign objects into the openings of any devices.
- Do not attempt to modify the recorder or SSDs.
- Do not use the recorder in a place where it or an SSD might get wet, or water might get inside them.
- The recorder is intended to work only with SSDs. Do not attempt to use non-SSDs, as that could damage the recorder.
- When inserting an SSD, make certain that it is not upside down or backwards, and do not attempt to force a bent or damaged SSD, as that could damage the card or SSD slot.
- While the recorder is recording or settings are being changed, do not disconnect the recorder's power cable (included in the separately sold Cable Kit). Before disconnecting the power cable, first stop all operations and turn the recorder off. Otherwise, the SSD may be damaged, or recorder setting files or management data on the SSD may be corrupted.
If the video and audio was recorded while being played back, several seconds of video and audio before the moment the power cable was disconnected will be lost.

Precautions for use of SSDs

- SSDs are formatted using the Front-End Application. SSDs formatted by any means other than the Front-End Application cannot be used with this recorder. (Refer to the Operating Instructions for Front-End Application)

■ Maintenance

- To clean the recorder, turn the vehicle's ignition switch to the LOCK (OFF) position, and keep the recorder power turned off (see "Off" on page 30).
- Do not use solvents such as benzene, thinner or alcohol, as these can deform the case or damage the surface finish.
- Use a soft, dry cloth to dust off the recorder.
- If using a chemically treated cloth, follow the instructions provided with it.

Control Reference Guide

Front panel (1)

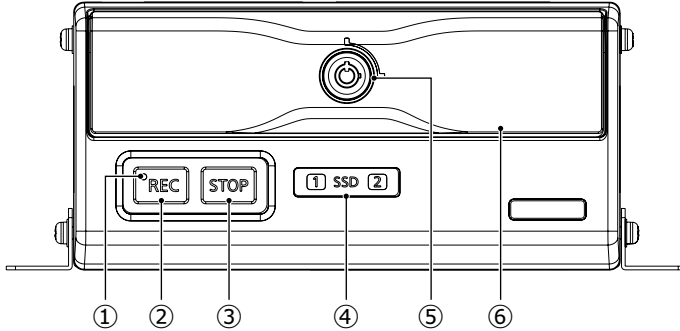

① **REC lamp**

Lights during recording. Flashes when the combined remaining recording time of drives inserted in SSD slots 1 and 2 is less than 30 minutes. (Refer to “Indicator Lamps and Recorder Status” in Section 2: Operation.)

② **REC button**

Starts recording of video and audio to an SSD.

③ **STOP button**

Stops recording.

④ **SSD lamps 1, 2**

Light green when recordable SSDs are inserted in the SSD slots.

⑤ **Lock**

Locks and unlocks the SSD slot cover.

⑥ **SSD slot cover**

Protects the SSDs. Recording is disabled when the cover is open.

Control Reference Guide (continued)

Front panel (2)

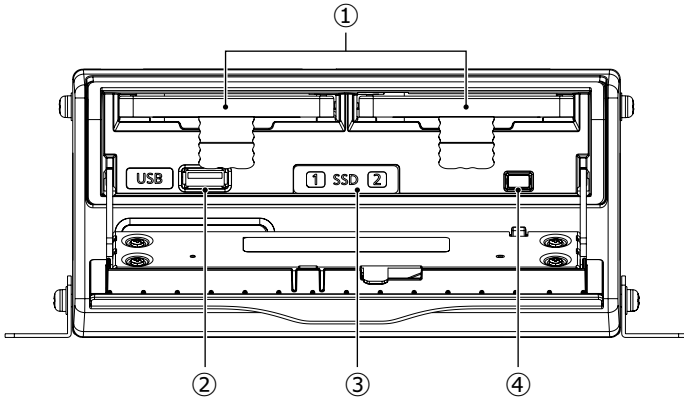

① **SSD slots 1, 2**

Insert SSDs here.
Up to two drives can be inserted simultaneously.

③ **SSD lamps 1, 2**

When SSD slot cover opened, if the light flashes, do not pull out the SSD.

② **USB connector**

This port is for maintenance use only.

④ **SSD slot cover detect switch**

Detects when the SSD slot cover is open.

Control Reference Guide (continued)

Rear panel (1)

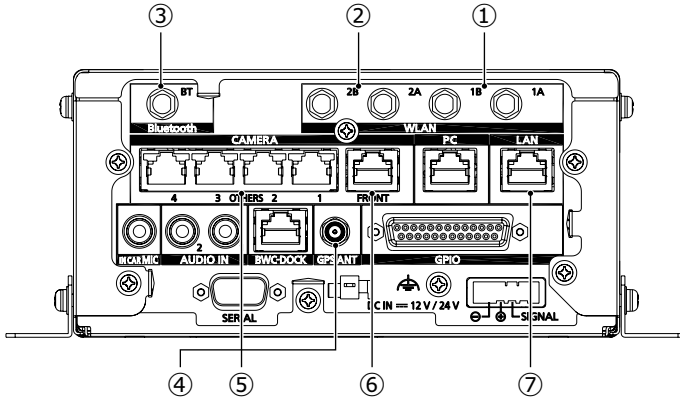

- ① **WLAN [1A, 1B] connector**
- ② **WLAN [2A, 2B] connector**
- ③ **Bluetooth [BT] connector**
- ④ **GPS ANT. connector**

Connect the 6 coaxial cables from the external antenna SH-IN2568 (locally procured) to the corresponding connectors.

The coaxial cables are labeled with "WIFI1", "WIFI2", "WIFI3", "WIFI4", "WIFI5", and "GPS / GNSS" respectively. Attach them to each connector as follows.

- Connect WIFI1 to WLAN [1A]
- Connect WIFI2 to WLAN [1B]
- Connect WIFI3 to WLAN [2A]
- Connect WIFI4 to WLAN [2B]
- Connect WIFI5 to Bluetooth [BT]
- Connect GPS / GNSS to GPS.ANT

Important:

- Antenna other than SH-IN2568 is not available.

Note:

- The external antenna SH-IN2568 contains built-in antennas of WLAN×2, BT and GPS.

- During GPS reception, the signals received will regularly and automatically set the recorder clock to GPS time, and provide speed information, if the recorder is attached to a vehicle.

- ⑤ **CAMERA [OTHERS 1, 2, 3, 4] connector**

Connect the Network Camera (sold separately) using shielded LAN cables.

- OTHER1 : For Back Seat Camera
- OTHER2 : For Side Camera (Left)
- OTHER3 : For Side Camera (Rear)
- OTHER4 : For Side Camera (Right)

- ⑥ **CAMERA [FRONT] connector**

Connect the Network Camera (sold separately) using shielded LAN cables.

- ⑦ **PC, LAN connectors**

Connect the recorder to PCs using shielded LAN cables.

Note:

For details on how to connect a PC, contact your supplier.

Control Reference Guide (continued)

Rear panel (2)

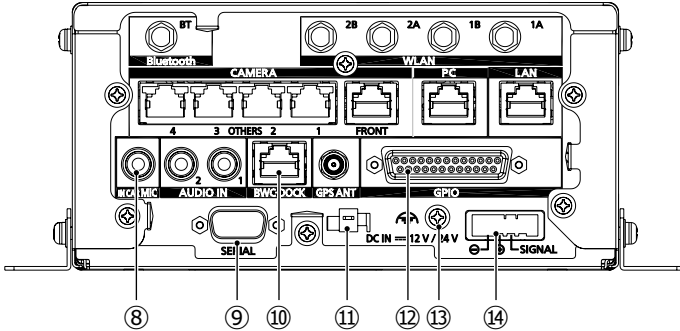

⑧ IN CAR MIC, AUDIO IN [1, 2] connectors

These are line and microphone level signal inputs. The output signals of audio components or wireless microphones can be connected here.
IN CAR MIC : MIC level input
AUDIO IN : Line level input

⑨ SERIAL connector

For RS-232C. Connect a commercially available radar gun.

⑩ BWC-DOCK connector

Connect the Single Dock Charger or Pairing Dock (Both are locally procured). You can connect an Ethernet cable to the Dock and communicate with the Body Worn Camera via the Dock for data transmission and pairing operation.

Note:

Can not charge Body Worn Camera from this connector by the Dock.

⑪ Cable Clamp

Use this clamp to secure cables.

⑫ GPIO connector

This combo connector accepts up to 16 trigger signal (GPI 1-16) inputs and supplies up to four signal (GPO1-4) outputs. Connect the trigger cable here (included in the separately sold Cable Kit).

⑬ Grounding screw [Functional grounding symbol (Functional earthing symbol)]

Connect this to the car's grounding.

⑭ DC IN connector [DC IN --- 12V/24V] Direct current symbol (---)

This connector accepts power from the vehicle battery. Connect the power cable here (included in the separately sold Cable Kit).

Note:

Do not pull out the power cable (included in the separately sold Cable Kit) while the recorder is running. Power loss, especially during access (for example, during recording) may damage the SSD or cause file corruption and corrupt the setting data of the recorder.

Control Reference Guide (continued)

Mounting bracket and ventilation

The recorder can be mounted by turning the mounting bracket 90 degrees in a center console or trunk. The figure below is an example of mounting in a trunk. (Factory default setting)

For center console mounting, remove the screw to remove the mounting bracket. Rotate the mounting bracket 90° and attach the screw again.

Panasonic i-PRO Sensing Solutions Co., Ltd. assumes no responsibility for injuries or property damage resulting from failures arising out of improper installation or operation inconsistent with this documentation.

Example of installation in a trunk

Step1

Loosen 4 mounting bracket attaching screws to remove the mounting brackets.

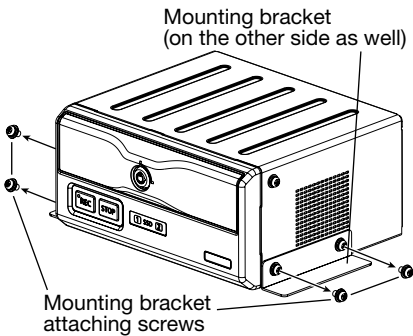

Step2

Drill 2 holes in each removed mounting bracket, 4 holes in total.

Step3

Attach the drilled mounting brackets to their original positions. Recommended tightening torque: 1.5 N·m {1.11 lbf·ft}

Step4

Fix the recorder to the trunk with fixing screws (4 pcs.) (M4 × 16 mm {5/8 inches}*, locally procured).

* The screw length is an example when installing the recorder on a robust trunk floor with a thickness of 20 mm {25/32 inches} or more.

Minimum pull-out strength: 196 N {44 lbf} (per 1 pc.)

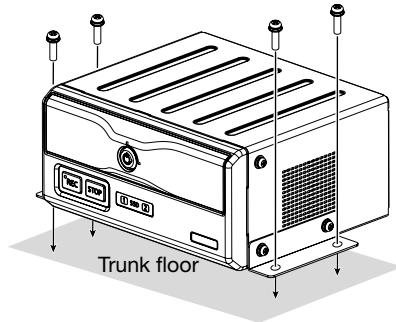

Note:

- Consult your supplier and request help with installation.

Control Reference Guide (continued)

Ventilation

Do not block the ventilation inlet or outlet.

Left side
Ventilation inlet

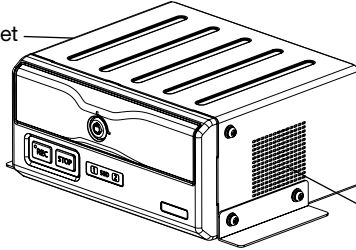

Right side
Ventilation outlet (fan)

Note:

- Leave at least 3 cm {1-1/4 inches} around the Ventilation inlet and outlet.

Connections

- You are recommended to connect the recorder to the power cable via an Automotive Distribution Center (manufactured by LIND ELECTRONICS, Inc.).
- Connect the red (BATT) and white (SIGNAL) power cable wires via a fuse (10 A). (A power cable is included in the separately sold Cable Kit.)
- Be sure to consult the supplier to have the power cable installed and connected.
- Connect the power cable from the passenger compartment fuse box. Use a commercially available automotive cable to provide power from the engine compartment to operate the recorder in the passenger compartment.

- Connect the power cable when all connections are completed. Be sure to read the instructions in the connector diagram on pages 28 through 29 and the operating instructions of the devices that will be connected.
- Verify that recording is not in progress prior to disconnecting any cables from the recorder. Be sure to disconnect the power cable first, and then disconnect any other cables.
- An incorrectly connected power cable could cause a fire or damage. Be sure to connect the power cable correctly.

Connections (continued)

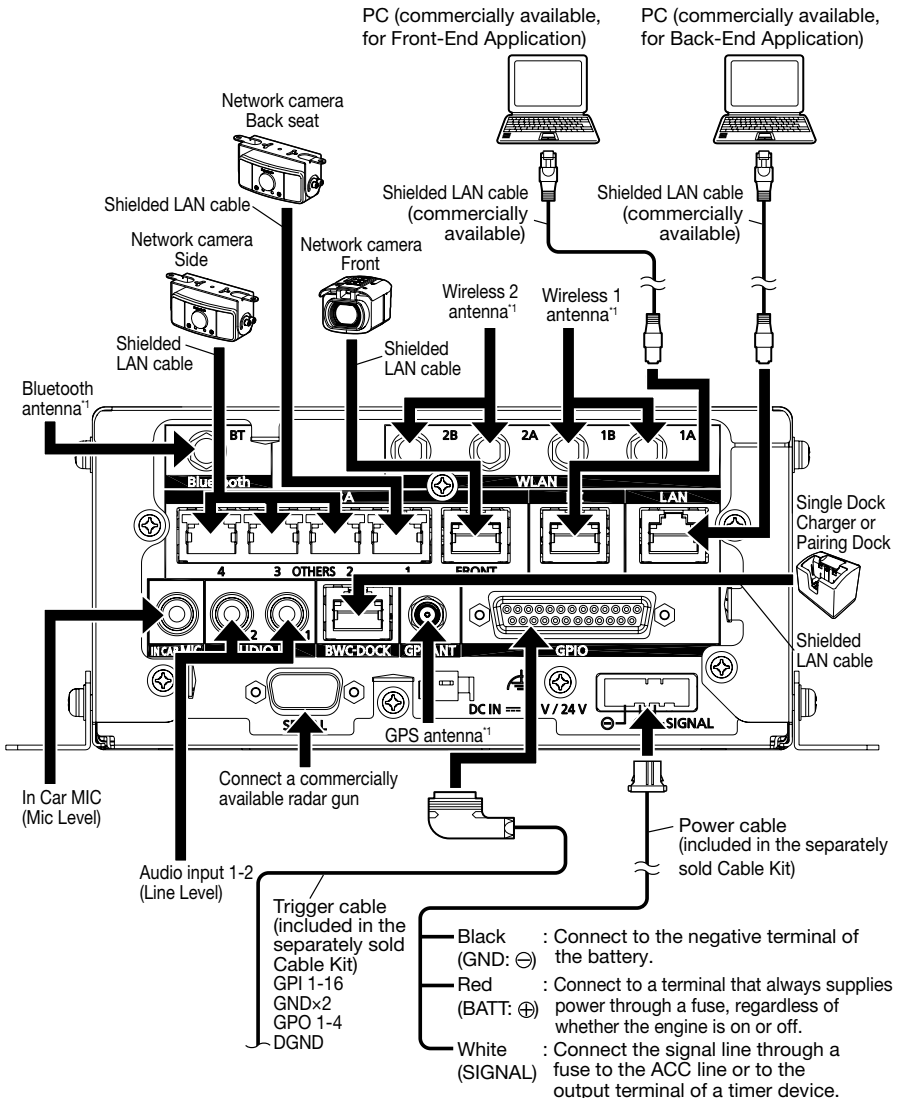

*1 Connect the coaxial cables from the integrated antenna SH-IN2568 to the Wireless 1 antenna, Wireless 2 antenna, Bluetooth antenna and GPS antenna.

Note:

- Confirm the compatible Windows version for PC in the Front-End Application user manual.
- The cameras illustrated in the above are examples.

SSD Insertion and Removal

Inserting an SSD

(1) Unlock the key.

Insert the key in the lock and turn it clockwise to [] and remove it.

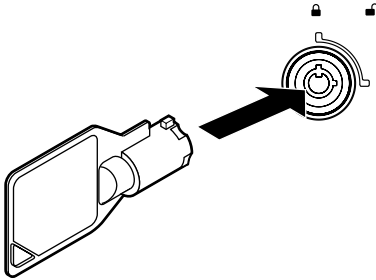

Note:

- Do not try to turn the key further than the stop position, and do not move it unnecessarily, to prevent damage to the key and lock.

(2) Open the SSD slot cover.

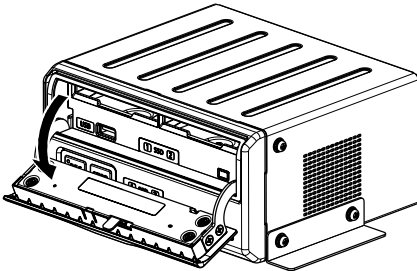

Note:

- To prevent damage, do not exert undue force on the open cover.

(3) Insert an SSD into an SSD slot.

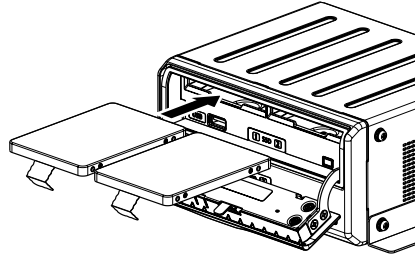

Note:

- Use officially supported SSD.

(4) Close the SSD slot cover.

Return the SSD slot cover to its original closed position by pushing to the end.

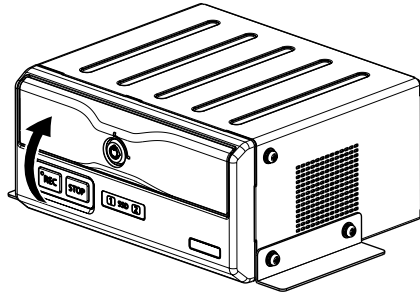

When you close the SSD slot cover after inserting an SSD, the [SSD] lamp indicates the recorder status. (Refer to “Indicator Lamps and Recorder Status” in Section 2: Operation.)

(5) Lock and remove the key.

Insert the key in the lock and turn it counterclockwise to [], and remove it.

SSD Insertion and Removal (continued)

Removing an SSD

- (1) Open the SSD slot cover
(see previous page).
- (2) Remove the SSD by pulling
on the ribbon attached to the
SSD.

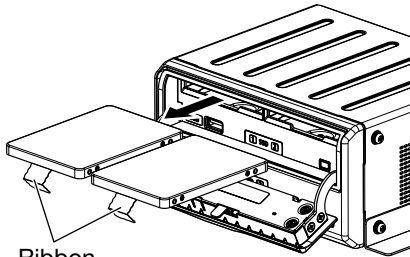

Ribbon

Note:

- Do not remove SSD when the SSD1 or SSD2 lamp blinks. Remove the SSD when the light goes off.
- If an SSD is removed while being accessed, the drive may be damaged.

- (3) Close the SSD slot cover.
Return the SSD slot cover to its original closed position by pushing to the end.

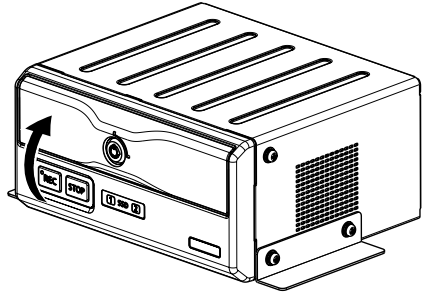

- (4) Remove the key.
Turn the key counterclockwise to [🔒], and remove it.

Turning the Recorder On and Off

Recorder power is supplied from the vehicle's battery.

On

Turn the vehicle's ignition switch to ON or ACC.

Power to the recorder is turned on.

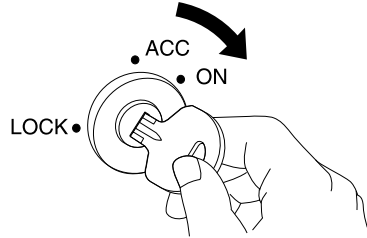

Off

Turn the vehicle's ignition switch to LOCK (OFF).

Power to the recorder is turned off.

Note:

The [Power Off Time] can be set to allow the recorder to continue operating after the vehicle's ignition switch is turned to LOCK (OFF).

Refer to the Operating Instructions for the Front-End Application.

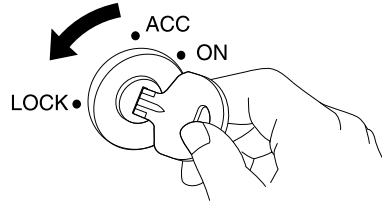

Connector Signals

[DC IN] connector
(male)

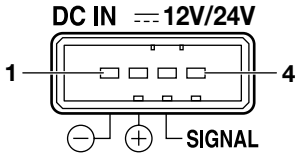

Pin number	Signal	Cable color
1	GND (⊖)	Black
2	BATT (⊕)	Red
3	SIGNAL*	White
4	N.C.	

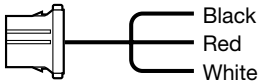

**Power cable (included in the
separately sold Cable Kit)**

* Recorder power can be turned on and off by the SIGNAL port. If an OFF signal is input while the recorder is operating, the recorder turns off after the time specified on Front-End Application.

Connector signals (continued)

[GPIO] connector (female)

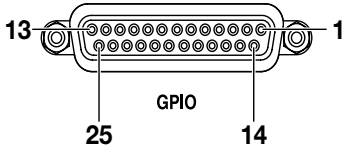

Trigger cable
(included in the separately
sold Cable Kit)

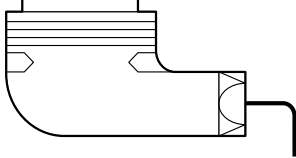

GPO 1	Open emitter output
GPO 2	Open emitter output
GPO 3	Open collector output
GPO 4	Power output of 5 V

Pin number	Signal	Cable color
1	GND	Black/White
2	N.C.	—
3	GPI 13	Pink
4	GPI 14	Light Green
5	GPI 15	Brown/White
6	GPI 16	Orange/White
7	GND (DIGITAL)	Green/Black
8	GPO 2	Green/White
9	GND	Black
10	GPI 1	Brown
11	GPI 2	Red
12	GPI 3	Orange
13	GPI 4	Yellow
14	GPI 9	Blue/White
15	GPI 10	Violet/White
16	GPI 11	Red/Black
17	GPI 12	Orange/Black
18	GPO 3	Yellow/Black
19	GPO 4	Red/White
20	N.C.	—
21	GPI 5	Green
22	GPI 6	Blue
23	GPI 7	Violet
24	GPI 8	Gray
25	GPO 1	White

[SERIAL] connector (male)^{*1}

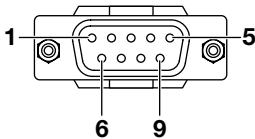

Pin number	Signal
1	N.C.
2	RxD
3	TxD
4	DTR
5	SG
6	DSR
7 ^{*2}	RTS
8 ^{*2}	CTS
9	N.C.

*1 Consult your supplier and request radar gun connection.

*2 Pins 7 and 8 on this recorder are short-circuited.

Troubleshooting

Before requesting service, check the points listed below. If the problem persists, contact your supplier.

■ Starting up

Symptom	Remedy
Power does not come on.	<ul style="list-style-type: none">• Check whether power cable (included in the sold separately Cable Kit) is connected correctly.

Specifications

Power requirements:

12 V DC / 24 V DC

Input current:

4.7 A (at 12 V DC)

2.3 A (at 24 V DC)

(When 5 cameras
are connected)

Current consumption in standby:

max. 5 mA

(12 V DC / 24 V DC)

 indicates safety information.

Operating temperature:

-10 °C to 50 °C {14 °F to 122 °F}

Storage temperature:

-20 °C to 60 °C {-4 °F to 140 °F}

Operating humidity:

10 % to 80 % (no condensation)

Mass

Approx. 2.0 kg {Approx. 4.4 lbs}

Dimensions (W x H x D)

(excluding protrusions and
recorder mounting brackets)

178 mm x 87 mm x 155 mm

{7 inches x 3-7/16 inches x 6-9/32
inches}

Recording media:

SSD (Solid State Drive)

■ Network

- LAN
RJ-45, 1000BASE-T/100BASE-TX
For upload data
- PC
RJ-45, 1000BASE-T/100BASE-TX
Connected to PC/Control panel
- CAMERA FRONT
RJ-45, 100BASE-TX w/ PoE
- CAMERA OTHERS 1 -4
RJ-45, 100BASE-TX w/ PoE

• BWC-DOCK

RJ-45, 100BASE-TX

For WV-BWC40D1A/WV-BWC40D1,
WV-TW37004A/WV-TW37004

Note:

CAMERA Port total power
consumption must be less than 26 W.

■ Audio

Inputs:

- AUDIO IN 1 - 2 (Pin jack) x 2
WMIC: -10 dBV, 25 kΩ, unbalanced
- IN CAR MIC (Pin jack) x 1
MIC: -50 dBV, 3 kΩ, unbalanced
(plug-in power approx. 4 V)

■ DC IN connector

SIGNAL port

Input voltage L: 0 V - 1.0V

H: 8 V - 28 V

Input current: 1 mA (max.)

■ I/O connectors

- GPIO connector x 1
D-Subminiature 25-pin
GPIO
Inputs: 16 ports
Input voltage L: 0 V - 1.0 V
H: 4 V - 28 V
Input current: 12 mA (max.)
(Time required to
detect changes: 100 ms)
- Outputs: 4 ports
Open-emitter output x 2
Output voltage: approx. 4.5 V
Output current: 15 mA (max.)
Open-collector output x 1
Input voltage: 4 V - 28 V
Input current: 25 mA (max.)
- DC output x 1
Output voltage: approx. 5.0 V
Output current: 50 mA (max.)

Specifications (continued)

- WIRELESS 1 ANT connector × 2
For the antenna SH-IN2568.
- WIRELESS 2 ANT connector × 2
For the antenna SH-IN2568.
- Bluetooth ANT connector × 1
For the antenna SH-IN2568.
- GPS ANT connector × 1
For the antenna SH-IN2568

■ Other connectors

- USB connector × 1
For maintenance
- SERIAL connector × 1
D-Subminiature 9-pin RS-232C
For Rader gun

Specifications (continued)

■ Others

• Wireless LAN

Communication Standard:	IEEE802.11 a/b/g/n/ac
Access mode:	Infrastructure mode MIMO : 2x2 2stream
Frequency Band (STA):	2.4 GHz band 2412 MHz to 2462 MHz (1-11 ch) 5 GHz band 5280 MHz to 5320 MHz (56, 60, 62, 64 ch) 5500 MHz to 5580 MHz (100, 102, 104, 106, 108, 110, 112, 116 ch) 5660 MHz to 5720 MHz (132, 134, 136, 138, 140, 142, 144 ch) 5745 MHz to 5825 MHz (149, 151, 153, 155, 157, 159, 161, 165 ch)
Frequency Band (AP):	2.4 GHz band 2412 MHz to 2462 MHz (1-11 ch) 5 GHz band 5745 MHz to 5825 MHz (149, 151, 153, 155, 157, 159, 161, 165 ch)
Security:	WPA-Personal WPA2-Personal WPA2-Enterprise

• Bluetooth

Bluetooth standard:	Bluetooth Low Energy (Ver4.2)
Frequency band:	2402 MHz to 2480 MHz
Support profile:	GATT (Generic attribute profile)
Modulation system:	Frequency Hopping Spread Spectrum (FH-SS)

• GPS (Global Positioning System)

Receive frequency:	1.57542 GHz (C/A code)
--------------------	------------------------

Mass and dimensions are approximate.
Specifications are subject to change without notice.

Panasonic i-PRO Sensing Solutions Corporation of America

800 Gessner Rd, Suite 700 Houston, TX 77024
<https://www.security.us.panasonic.com/>

Panasonic Canada Inc.

5770 Ambler Drive, Mississauga, Ontario, L4W 2T3 Canada
1-877-495-0580
<https://www.panasonic.com/ca/>