

DECT Microphone System
Receiver Board Module
for **AUDIO ENHANCEMENT**
Specifications

Audio Enhancement Approval	
Panasonic. Approval	

Ver. 1.0

November 29, 2019
Panasonic Corporation



■ INDEX

Ver. 1.0.....	i
1. GENERAL	4
2. FEATURES	4
3. SPECIFICATIONS.....	4
3.1. Product Specifications	4
3.2. Accessory	8
4. SAFETY REQUEST	9
5. BLOCK DIAGRAM.....	10
6. APPEARANCE	11
7. CONTROL TERMINAL SPECIFICATIONS	13
7.1. Electrical specifications.....	13
8. PACKAGING SPECIFICATIONS	16
8.1. Packaging specifications	16
9. FCC AND INDUSTRY CANADA REQUIREMENTS REGARDING THE END PRODUCT.....	17
9.1. List of applicable FCC and IC rules	17
9.2. FCC rules that must be complied with in the end product.....	17
9.3. IC rules that must be complied with in the end product.....	17
9.4. Requirement of regarding the end product and manual.....	18
9.5. Notice.....	19

No.	Ver. Date	Revision	Change Time	Sign	Check
1	1.0	Draft The blue sentences is the changing points from K-SRC14 (Wireless Receiver).	29/Nov/2019	Mitsutoshi Nozawa	Motoshi Suzuki

1.GENERAL

- These specifications describe the preliminary specifications of “Receiver Board Module for DECT Microphone System” for Audio Enhancement (AE).

2.FEATURES

- Receiver Board Module has same features and outside interface as DECT Receiver (K-SRC14).
- System specifications and system functions including microphones are same as "DECT Microphone System" with Receiver, so refer to “DECT Microphone System for Audio Enhancement Specifications”, with replace "Receiver" to "Receiver board module."

3.SPECIFICATIONS

3.1.Product Specifications

GENERAL

Combined AE's product	: BEAM, XDSolo
Power	: 24VDC (minimum 21.6VDC~maximum 26.4VDC) input from AE's product (BEAM or XDSolo)
Input current	: 130mA
Dimensions	: 150mm(W)x 114mm(H) x 18mm(D)
Weight	: 85g
Temperature Range	: 0 °C ~ +50°C (around Receiver Board Module)
Humidity Range	: ~ 90%
The Condition of Installation	: Indoor, Fixed Installation
Mounting direction	: Only vertical direction with antenna facing upward

LINE Inputs

The number of connectors	: 1 Stereo input (Tip:Left, Ring:Right, Sleeve:GND) 1/8" (3.5 mm) Stereo phone Jack
Internal Bus	: Mono Mixing
Input Level	: -10dBV Unbalanced
Input Impedance	: 10kΩ or more

OUTPUT

The number of connectors	: 1 Mono output (Mix output Unbalanced) 1/8" (3.5 mm) Stereo phone Jack
Adapted Load Impedance	: 10kΩ or more
Nominal Output Level	: -10dBV
Residual Noise	: -60dBV or less

OUTPUT (Amplifier interface)

Connectors	:	RJ-45 (Type for LAN), connect to Amplifier
Adapted Load Impedance	:	10k Ω or more
Nominal Output Level	:	
Mic output 1,2	:	-5dBV Balanced
Mix output	:	0dBV Balanced
Residual Noise	:	-60dBV or less

GENERAL SPECIFICATIONS for AUDIO

Cross talk	:	-45dB or more @ 1kHz
Dynamic Range	:	80dB or more (Line In to Mix output Balanced)
	:	80dB or more (Line In to Mix output Unbalanced)
	:	85dB or more (Receiver to Mic/Mix output Balanced)
		By auto level control function in Microphone
Signal to noise ratio (S/N)	:	60dB or more (Line In to Mix output Balanced)
	:	60dB or more (Line In to Mix output Unbalanced)
	:	60dB or more (Receiver to Mic/Mix output Balanced)
Frequency Response	:	100Hz ~ 7kHz,
	:	0dB \pm 3dB (Line In to Mix output)
	:	0dB \pm 3dB (Receiver to Mic output)
Total Harmonic Distortion	:	3.0% or less (Line In to Mix output)
	:	3.0% or less (Receiver to Mic output)
Attenuator	:	Built-in each output (Mic output 1,2, Mix output)
		0 dB ~ -32dB /2step
		-32dB ~ -48dB /4step,-60dB,-70dB, OFF
		(Controlled from Pendant type microphone and RS-232C)
Mixing output attenuator	:	-10dB attenuator build in to mixing output.
		Set by dip switch

FEEDBACK BLOCKER

Assignment	:	Mic Channe1 and Mic Channel 2
Filter	:	5 band Filter
Operation	:	3 step operation
		1st Step : Searching Feedback point and enable a filter
		2nd Step: Add 6dB attenuation to 1st step
		3rd Step: Full attenuation

RESPONSE TONE

Number of tone signal	:	Five tone signals are build-in
		※refer to “AE DECT Mic Specification” -2.9 TONE”

OTHER FUNCTIONS

- Teacher's over ride : This function will work when voice come into input from Mic CH1 or CH2. Then Mix-output level will be set to fixed attenuate level.
Available On/Off control by Dip switch
Attenuation = 12dB or more
- Paging mute : When Paging mute terminal is activated, this function will be work.
At this time, Mic output channel 1 and 2, Mix-output level set to Mute Level.
Attenuation = 40dB or more
- Mic mixing : Mic channel 1 and 2 are available to assign to the Mix output
This function is set by RS-232C control only

CONTROL TERMINAL

- The number of connectors : 7pin and 8pin Euro type connector
- E1 output : CONT=Maximum control voltage 30V
Maximum control current 20mA
Opt-isolated open collector
COM =common
- E2 output : CONT=Maximum control voltage 30V, Dry contact
Maximum control current 20mA
Opt-isolated open collector
COM =common
- E2 acknowledgement : IN = Pull to GND
Short current 2mA
5VDC always appear on the terminal
GND=GND
- Page Mute : IN = Pull to GND
Short current 2mA
5VDC always appear on the terminal
GND=GND
- Serial port (RS-232C) : TxD= Transmission port
RxD=Receiver port
GND=GND
Baudrate and protocol =
9600 bps, 8 data bits, 1 stop bit, No parity
Maximum distance = 15m
- LINK Button : IN = Pull to GND
Short current 2mA
5VDC always appear on the terminal
GND=GND
- Alert Notification Button : IN = Pull to GND
Short current 2mA
5VDC always appear on the terminal
GND=GND

INTERFACE CONNECTOR

Amplifier interface

Connector	:	RJ-45 (Type for LAN) , connect to Amplifier
Recommended Cable	:	LAN Cable (CAT5)
Pin assignment	:	1: Mic output 1 Hot 5: GND 2: Mic output 1 Cold 6: Mix output Cold 3: Mix output Hot 7: Mic output 2 Hot 4: Power DC24V 8: Mic output 2 Cold

DIP SWITCHES

Teacher's Over Ride	:	No1-1 *ON/OFF, setting function When set to ON, Teacher's over ride is enabled. When teacher's voice will be detected on each Mic input, The line input will set to mute level.
Response Tone	:	No1-2 *ON/OFF When set to ON, The tone signal will be assigned to Mix-output
Response Tone Level	:	No1-3 ON(HIGH)/ *OFF(LOW),setting tone level
Microphone Mix setting	:	No1-4 *ON/OFF When set to ON, Mic CH1&CH2 will be Mixed to the Mix-output
Feedback Blocker	:	No1-5 ON/*OFF, setting function
Volume Control Bypass (Remote volume)	:	No1-6 ON/*OFF This function will disable volume control from the tear-drop-microphone, and provide a volume control of the external device via RS-232C
Mixing output attenuator	:	No1-7 *ON/OFF When set to ON , -10dB attenuator of mixing output is enabled This will be used for match a audio level to next equipment.
RF Tx power setting	:	No1-8 ON(mode2; HIGH)/ *OFF(mode1; Normal)
Channel 3 VOL Line/Mic Alert ON/OFF	:	No2-1 ON(MIC/MDS)/ *OFF(LINE). No2-2 *ON/OFF When set to ON , Receiver receives a SAFE Alert
Not use	:	No2-3 to 8 ON/*OFF

Note *: Factory setting

SWITCH

LINK Button	:	[LINK] For Audio link up or registration
-------------	---	---

INDICATOR

Mic1 Indicator	:	1 LED (2 colors LED) Refer to soft specifications
Power Indicator	:	2 LED (2 colors LED) Refer to soft specifications
Mic2 Indicator	:	3 LED (2 colors LED) Refer to soft specifications
LINK Indicator	:	4 LED (2 colors LED) Refer to soft specifications

RF COMMUNICATION

- Antenna : The number of Antenna: 2
Antenna type: Dipole
Frequency range: 1,920 – 1,930 MHz
Antenna gain: 0dBi

- Specified Output Power : [Mode 1] (NORMAL) 0dBm (to Microphone)
[Mode 2] (Hi POWER) 5dBm (to Microphone)

- Coverage : [Mode 1] (NORMAL) 20m
[Mode 2] (Hi POWER) 30m

- Diversity Support : Space Diversity (Except Broadcast)
No Slot Diversity

3.2.Accessory

Unattached:

- Operating Instructions : None. Total operating instructions are prepared by Audio Enhancement.
- Warranty Card : None, the warranty period is described in the contract.

4.SAFETY REQUEST

In order to comply with the Panasonic Safety Regulations, take one of the following action on the AE product side.

-Add the circuit protection element (“PRCP-NSMF020/30X” made by COPAL ELECTRONICS) to the board in AE product which supplies the power to Receiver board

5.BLOCK DIAGRAM

Receiver Board Module

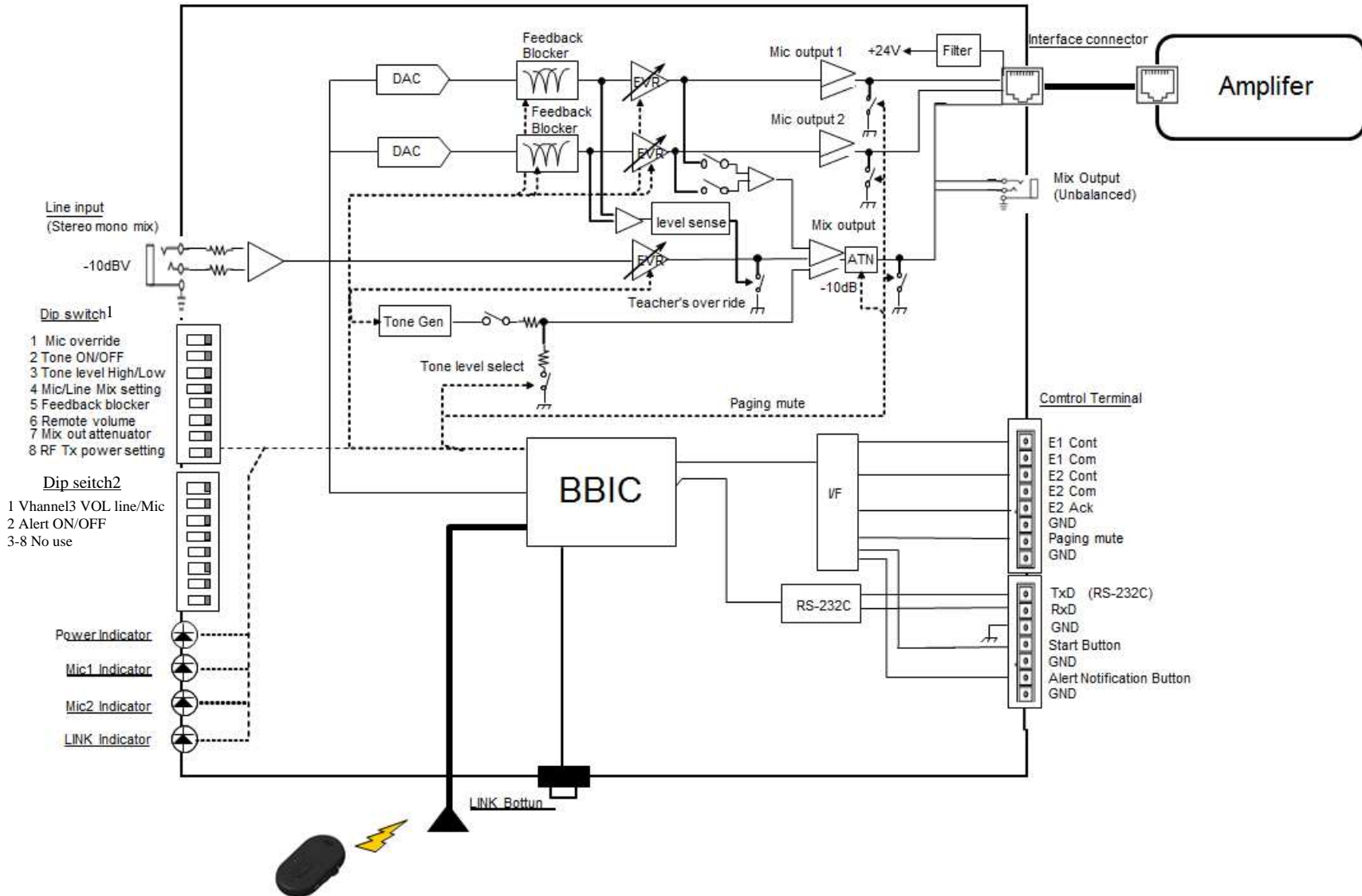

6.APPEARANCE

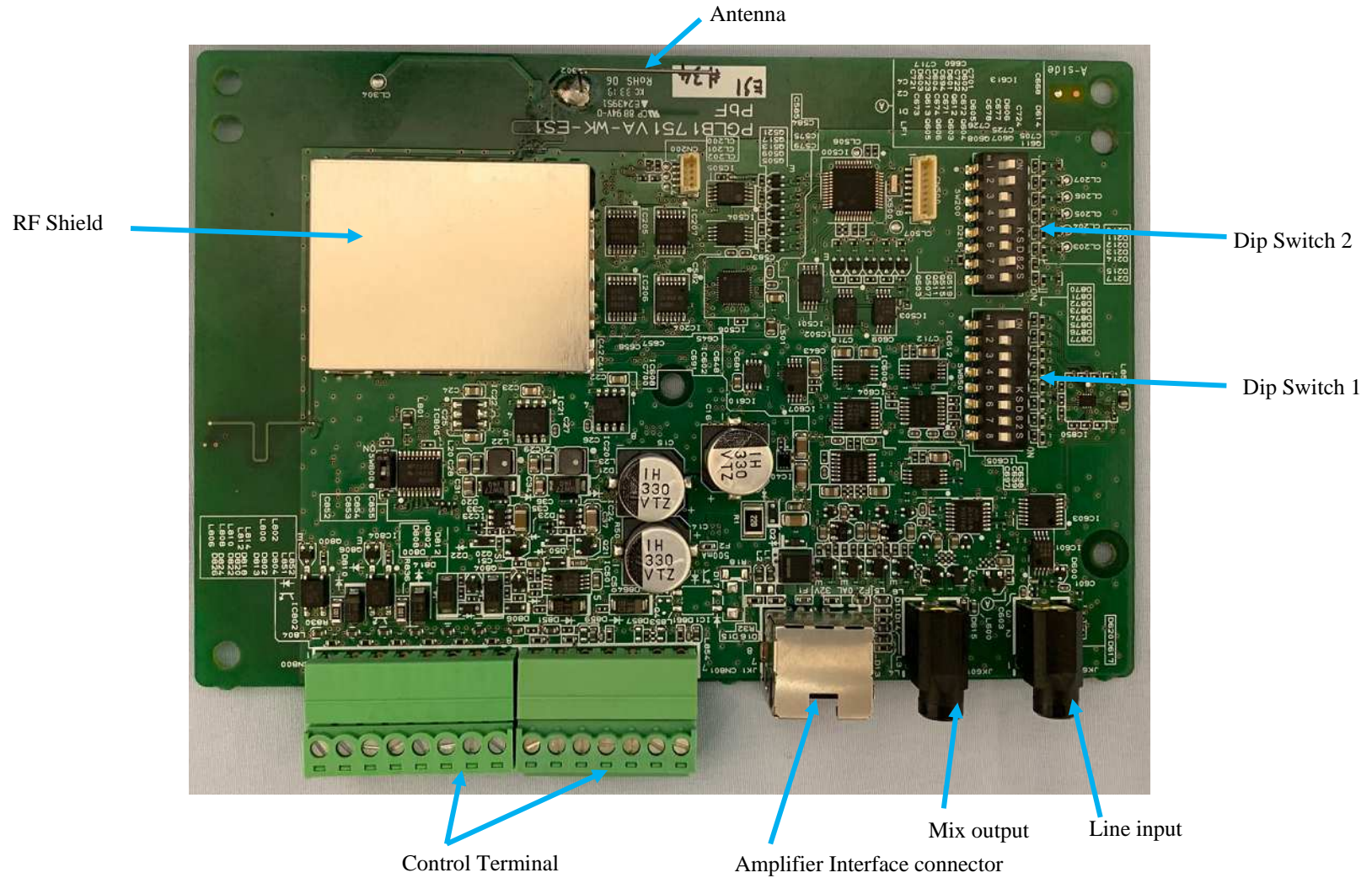

Name plate label

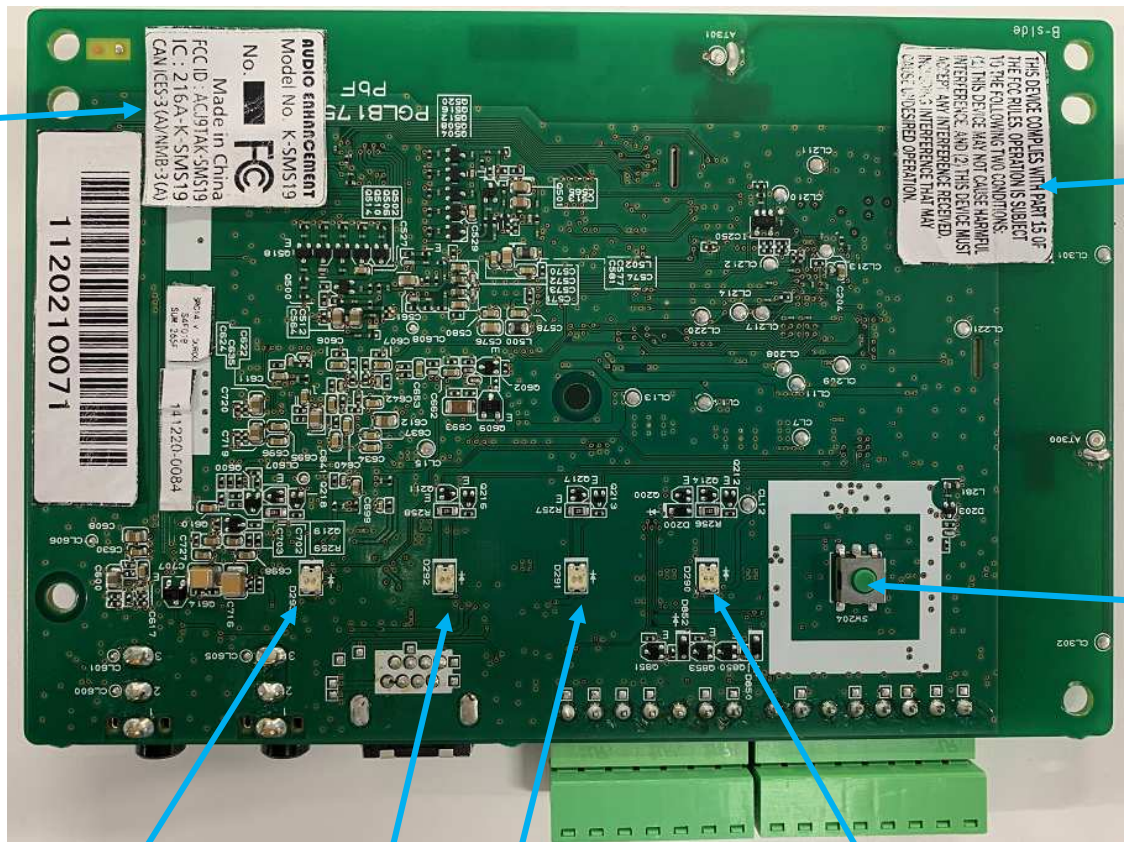

FCC Caution Label

LINK Button

Mic status indicator for CH1

Mic status indicator for CH2

Power indicator

LINK indicator

7.CONTROL TERMINAL SPECIFICATIONS

7.1.Electrical specifications

a. E1,E2 terminal

- Output circuit type is open collector. It has diode to prevent reverse connection.
- The terminal could drive until 20mA against the load equipment
- Maximum voltage rating is 30VDC

Name	I/O	Electrical specifications	Equivalent Schematic
E1 E2	output	Max control Voltage : 30V Max control current : 20mA	

b. E2 Ack terminal

- Input configuration is transistor. It has diode to prevent reverse current.
- Designed for external device which has dry contact like relay output.
- 5VDC will always appear on the terminal.
- Short current is 2mA If the terminal will be shorted by external device.

Name	I/O	Electrical specifications	Equivalent Schematic
E2 Ack	input	Terminal voltage:5V Short current:2mA	

c. Page mute terminal

- Input configuration is transistor. It has diode to prevent reverse current
- Designed for external device which has dry contact like relay output.
- 5VDC will always appear on the terminal.
- Short current is 2mA If the terminal will be shorted by external device.

Name	I/O	Electrical specifications	Equivalent Schematic
Page mute	input	Terminal voltage:5V Short current:2mA	

d. LINK Button terminal

- Input configuration is transistor. It has diode to prevent reverse current
- Designed for external device which has dry contact like relay output.
- 5VDC will always appear on the terminal.
- Short current is 2mA If the terminal will be shorted by external device.

Name	I/O	Electrical specifications	Equivalent Schematic
LINK Button	input	Terminal voltage:5V Short current:2mA	

e. Alert Notification Button terminal

- Input configuration is transistor. It has diode to prevent reverse current
- Designed for external device which has dry contact like relay output.
- 5VDC will always appear on the terminal.
- Short current is 2mA If the terminal will be shorted by external device.

Name	I/O	Electrical specifications	Equivalent Schematic
Alert Notification Button	input	Terminal voltage:5V Short current:2mA	

8.PACKAGING SPECIFICATIONS

8.1.Packaging specifications

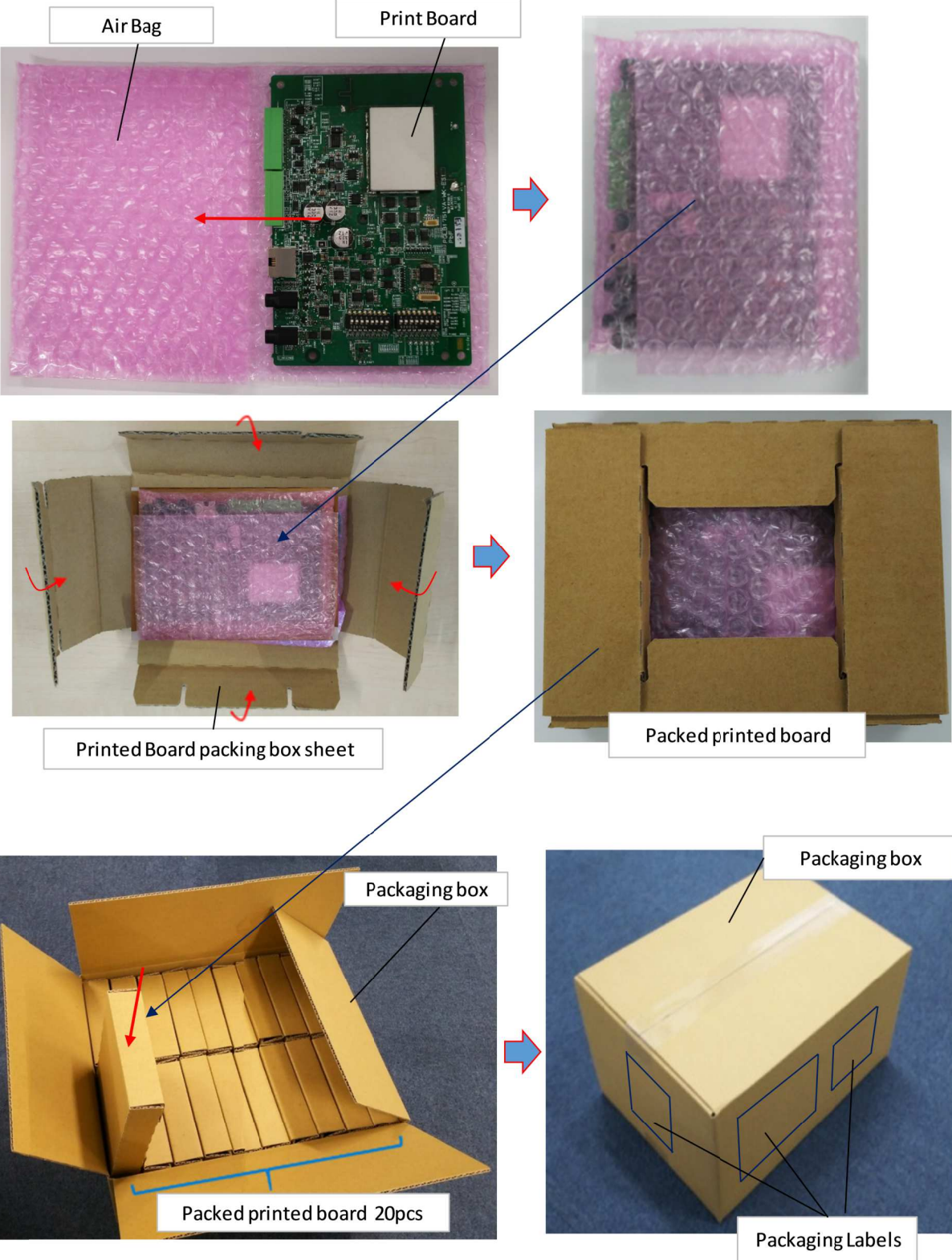

Dimensions of Packing box : 340mm(W)x 270mm(D) x 18mm(H)

9.FCC AND INDUSTRY CANADA REQUIREMENTS REGARDING THE END PRODUCT

9.1.List of applicable FCC and IC rules

K-SRB20 (Receiver Board Module) complies with FCC part15 subpart D and Industry Canada RSS 213 Issue3.

9.2.FCC rules that must be complied with in the end product

K-SRB20 (Receiver Board Module) is only FCC authorized for the specific rule FCC part 15 subpart D listed on the grant, and that the host product manufacturer is responsible for compliance to any other FCC rules that apply to the host not covered by the modular transmitter grant of certification. The end product manufacturer is responsible for compliance to any other FCC rules FCC part15 subpart B.

9.3.IC rules that must be complied with in the end product

K-SRB20 (Receiver Board Module) is only IC authorized for the specific rule Industry Canada RSS 213 Issue3 listed on the grant, and that the host product manufacturer is responsible for compliance to any other ICC rules that apply to the host not covered by the modular transmitter grant of certification. The end product manufacturer is responsible for compliance to any other ICC rules ICES-003 issue 6.

9.4. Requirement of regarding the end product and manual

End product and literature provided to the end user must include the following wording:

Wording	Display location
Contains Transmitter Module FCC ID:ACJ9TAK-SRB20 IC:216M-KSRB20	User manual and end product
CAN ICES-3(A)/NMB-3(A)	User manual and end product
FCC Caution: Changes or modifications not expressly approved by the party responsible for compliance could void the user's authority to operate the equipment.	User manual
This device complies with Part 15 of the FCC Rules and Innovation, Science and Economic Development Canada's licence-exempt RSS(s). Operation is subject to the following two conditions: (1) This device may not cause harmful interference, and (2) this device must accept any interference received, including interference that may cause undesired operation.	User manual and end product. If it cannot be displayed on the end product, it must be displayed on the packaging box
NOTE: This equipment has been tested and found to comply with the limits for a Class A digital device, pursuant to part 15 of the FCC Rules. These limits are designed to provide reasonable protection against harmful interference when the equipment is operated in a commercial environment. This equipment generates, uses, and can radiate radio frequency energy and, if not installed and used in accordance with the instruction manual, may cause harmful interference to radio communications. Operation of this equipment in a residential area is likely to cause harmful interference in which case the user will be required to correct the interference at his own expense.	User manual
FCC RF Exposure Warning: To comply with FCC RF exposure requirements in uncontrolled environment: – This equipment must be installed and operated in accordance with provided instructions and a minimum 20 cm (8 inches) spacing must be provided between antenna and all person's body (excluding extremities of hands, wrists, feet and ankles) during wireless modes of operation.	User manual
This transmitter must not be co-located or operated in conjunction with any other antenna or transmitter.	User manual
RSS-Gen · Under Industry Canada regulations, this radio transmitter may only operate using an antenna of a type and maximum (or lesser) gain approved for the transmitter by Industry Canada. To reduce potential radio interference to other users, the antenna type and its gain should be so chosen that the equivalent isotropically radiated power (e.i.r.p.) is not more than that necessary for successful communication. · This device contains licence-exempt transmitter(s)/receiver(s) that comply with Innovation, Science and Economic Development Canada's licence-exempt RSS(s). Operation is subject to the following two conditions: 1. This device may not cause interference. This device must accept any interference, including interference that may cause undesired operation of the device. L'émetteur/récepteur exempt de licence contenu dans le présent appareil est conforme aux CNR d'Innovation, Sciences et Développement économique Canada applicables aux appareils radio exempts de licence. L'exploitation est autorisée aux deux conditions suivantes : 1. L'appareil ne doit pas produire de brouillage; L'appareil doit accepter tout brouillage radioélectrique subi, même si le brouillage est susceptible d'en compromettre le fonctionnement.	User manual

9.5.Notice

1. This module (K-SRB20) is not the Limited Module.
2. There is no trace antenna design in the end product.