



Panasonic Model KX-TG210 Series
900 MHz / 2.4 GHz Spread Spectrum Cordless Telephone System
FCC ID: ACJ96NKX-TG210

Certelecom Laboratories Inc.

Safety - EMI - Telecom - ISO Guide 25

ENGINEERING TEST REPORT

**ON:
THE PANASONIC CANADA INC.
"2.4 GHz SPREAD SPECTRUM CORDLESS TELEPHONE"**

**IN ACCORDANCE WITH:
FCC PART 15, SUBPART B
RADIO RECEIVERS**

PROJECT NO.: 8R00161

TESTED FOR:

PANASONIC CANADA INC.
5770 AMBLER DRIVE
MISSISSAUGA, ONTARIO
L4W 2T3

TESTED BY:

CERTELECOM LABORATORIES INC.
3325 RIVER ROAD, R.R. 5
OTTAWA, ONTARIO K1V 1H2

MAY 1998

This document contains 22 pages including this one.

Certelecom Laboratories Inc. authorizes the above named company to reproduce this report provided it is reproduced in its entirety and for use by the company's employees only.

Any use which a third party makes of this report, or any reliance on or decisions to be made based on it, are the responsibility of such third parties. Certelecom Laboratories Inc. accepts no responsibility for damages, if any, suffered by any third party as a result of decisions made or actions based on this report.

This report applies only to the items tested.

EQUIPMENT: 2.4 GHz Spread Spectrum Cordless Telephone

DESCRIPTION OF EQUIPMENT:

MODEL NO.: KX-TG210

SERIAL NO.: None

GENERAL:

These test were conducted on a sample of the equipment for the purpose of demonstrating compliance with FCC Part 15, Subpart B requirements for Radio Receivers.

The equipment was tested for conducted emissions from 0.45 MHz to 30 MHz using a 50 microhenry line impedance stabilization network (L.I.S.N.) as described in ANSI C63.4-1992. Peripheral equipment was also operated through a 50 microhenry L.I.S.N.

The equipment was tested for radiated emissions in accordance with the requirements of FCC Part 15, Subpart B. Frequencies were initially identified in a large shielded room. Amplitude measurements were made on an outdoor Open Area Test Site. Details of the outdoor site are on file with the FCC.

ABSTRACT:

NAME OF TEST	PARA. NO.	RESULTS
Powerline Conducted Emissions	15.107(a)	Complies
Radiated Emissions	15.109(a)	Complies

THIS TEST REPORT RELATES ONLY TO THE ITEM(S) TESTED.

THE FOLLOWING DEVIATIONS FROM, ADDITIONS TO, OR EXCLUSIONS FROM THE TEST SPECIFICATIONS HAVE BEEN MADE. None

TESTED BY: Kevin Carr
Kevin Carr, Technologist

DATE: 02 June 1998

APPROVED BY: Tom Tidwell
Tom Tidwell, Senior Technologist

DATE: 02 JUNE 1998

EQUIPMENT: 2.4 GHz Spread Spectrum Cordless Telephone

EQUIPMENT DETAILS

Type of Equipment:	Cordless Telephone
Manufacturer:	Panasonic
Model No.:	KX-TG210
Serial No.:	None
Frequency Range:	909.64 MHz to 920.8 MHz
No. of Channels:	32
Operating Frequency(ies) of Sample:	909.64 MHz to 920.8 MHz
Crystal Frequency(ies):	
Primary Power Requirement:	120 VAC, 60 Hz to 12 Vdc
Bandwidth and Emission Designator:	1.6 MHz, F1D

EQUIPMENT: 2.4 GHz Spread Spectrum Cordless Telephone

THEORY OF OPERATION

The Panasonic KX-TG210 Cordless Telephone utilizes direct sequence spread spectrum modulation techniques. The base unit transmits in the frequency range of 2402.08 MHz to 2481.44 MHz and receives between 909.64 MHz to 920.8 MHz. The handset transmits between 909.64 MHz and 920.8 MHz. The base unit can be used as a stand alone entity by utilizing the built in microphone.

EQUIPMENT: 2.4 GHz Spread Spectrum Cordless Telephone

JUSTIFICATION

The E.U.T. was configured for testing as per typical installation. Position and bundling of cables were investigated to establish maximum amplitude of emissions.

The following combinations were investigated to establish worst case configuration:

- (1) Base Station antenna up.
- (2) Base Station antenna parallel to table top.

EXERCISE PROGRAM

The E.U.T. exercise program used during radiated and conducted testing was designed to exercise the various system components in a manner similar to typical use.

Exercise mode:

- (1) Customer supplied test mode.

EQUIPMENT: 2.4 GHz Spread Spectrum Cordless Telephone

EQUIPMENT MODIFICATIONS

To achieve compliance the following change(s) were made by (Certelem) (customer) during compliance testing:

(1)

(2)

(3)

(4)

(5)

(6)

NOT APPLICABLE

EQUIPMENT: 2.4 GHz Spread Spectrum Cordless Telephone

Equipment Configuration List:

Item	Description	FCC ID:	Model No.	Serial.	Rev.
(A)	Base Unit	None	KT-TG210	None	
(B)	Handset	None	KT-TG210	None	
(C)	Headset	None	KT-TG210	None	
(D)	AC To DC Converter	None	None	None	

Inter-connection Cables

None

Configuration of the Equipment Under Test (E.U.T)

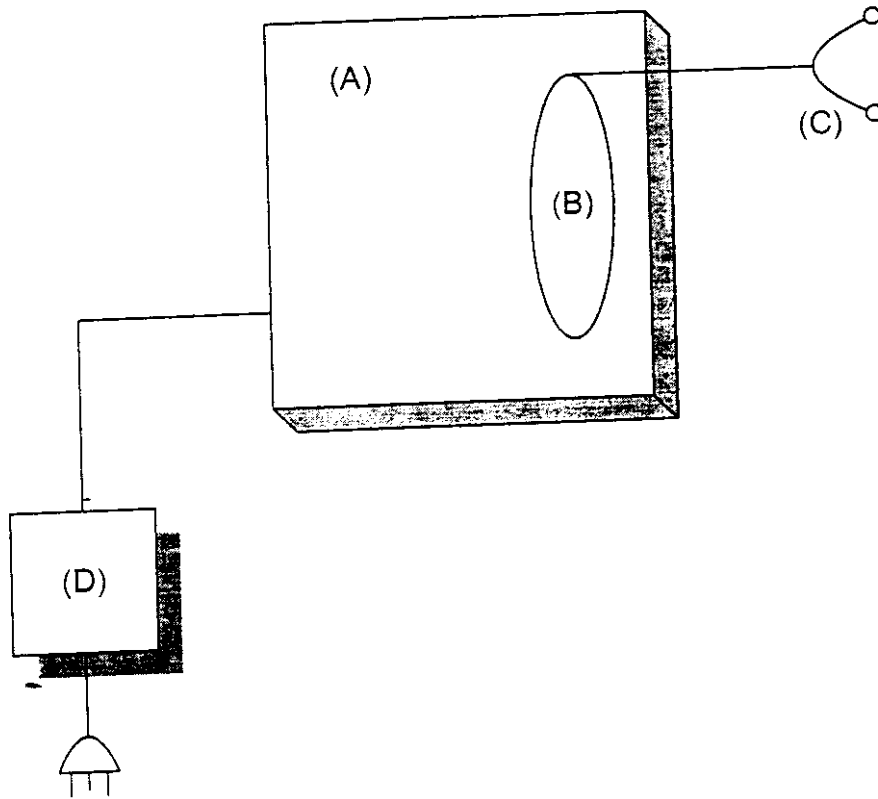

EQUIPMENT: 2.4 GHz Spread Spectrum Cordless Telephone

NAME OF TEST: Powerline Conducted Emissions	PARA. NO.: 15.107(a)
TESTED BY: Kevin Carr	DATE: April 17, 1998

TEST CONDITIONS: Standard Temperature and Humidity:
Standard Test Voltage:

MINIMUM STANDARD: The RF energy fed back into the power lines shall not exceed 48 dB μ V on any frequency between 0.45 MHz and 30 MHz inclusive.

TEST RESULTS: Complies. See attached graphs.

MEASUREMENT DATA: See attached graphs.

Measurements were made using a spectrum analyzer with 10 kHz RBW, Peak detector. Any emissions that are close to the limit are measured using a test receiver with 10 kHz bandwidth, CISPR Quasi-Peak detector.

Broadband emissions are identified by switching the receiver detector function from Quasi-Peak to Average. If the amplitude of the emission drops by 6 dB or more then the emission is classified as broadband and the Quasi-Peak level is reduced by a factor of 13 dB.

Neutral

April 17, 1998

8r00161_2 10dB Limiter used

REF 90.0 dBµV' ATTEN 10 dB

hp

10 dB/

PROJECT NO: 8R00161

PAGE NO. 11

POWERLINE CONDUCTED EMISSIONS

POWER OUTPUT: 0.0W

MOD.: NONE

DL

38.0

dBµV

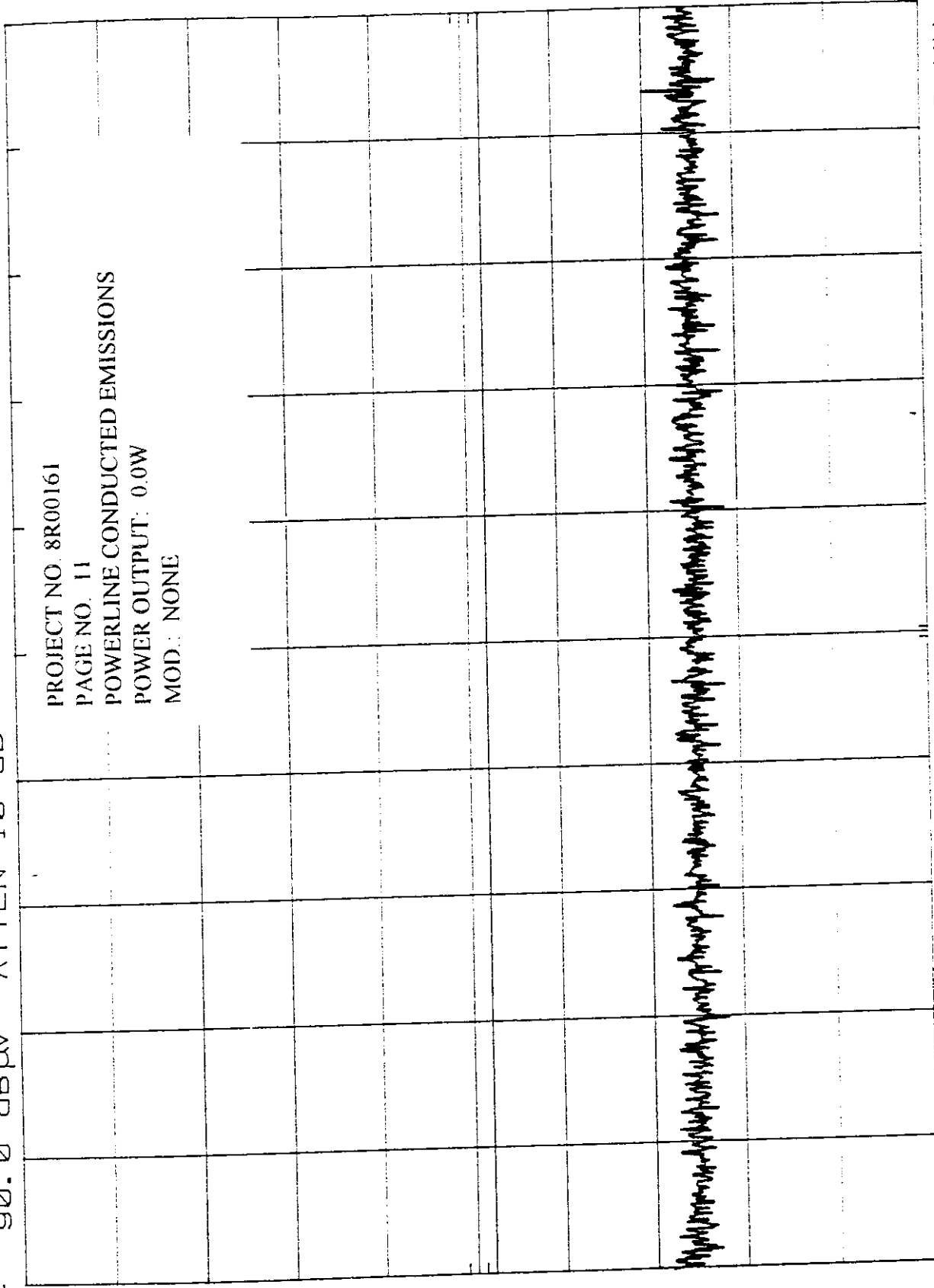

START 450 kHz

RES BW 10 kHz

VBW 30 kHz

STOP 30.0 MHz

SWP 887 msec

Phase

Apr 11 17, 1998

8r00161_2 10dB Limiter used

REF 90.0 dBμV ATTEN 10 dB

hp

10 dB/

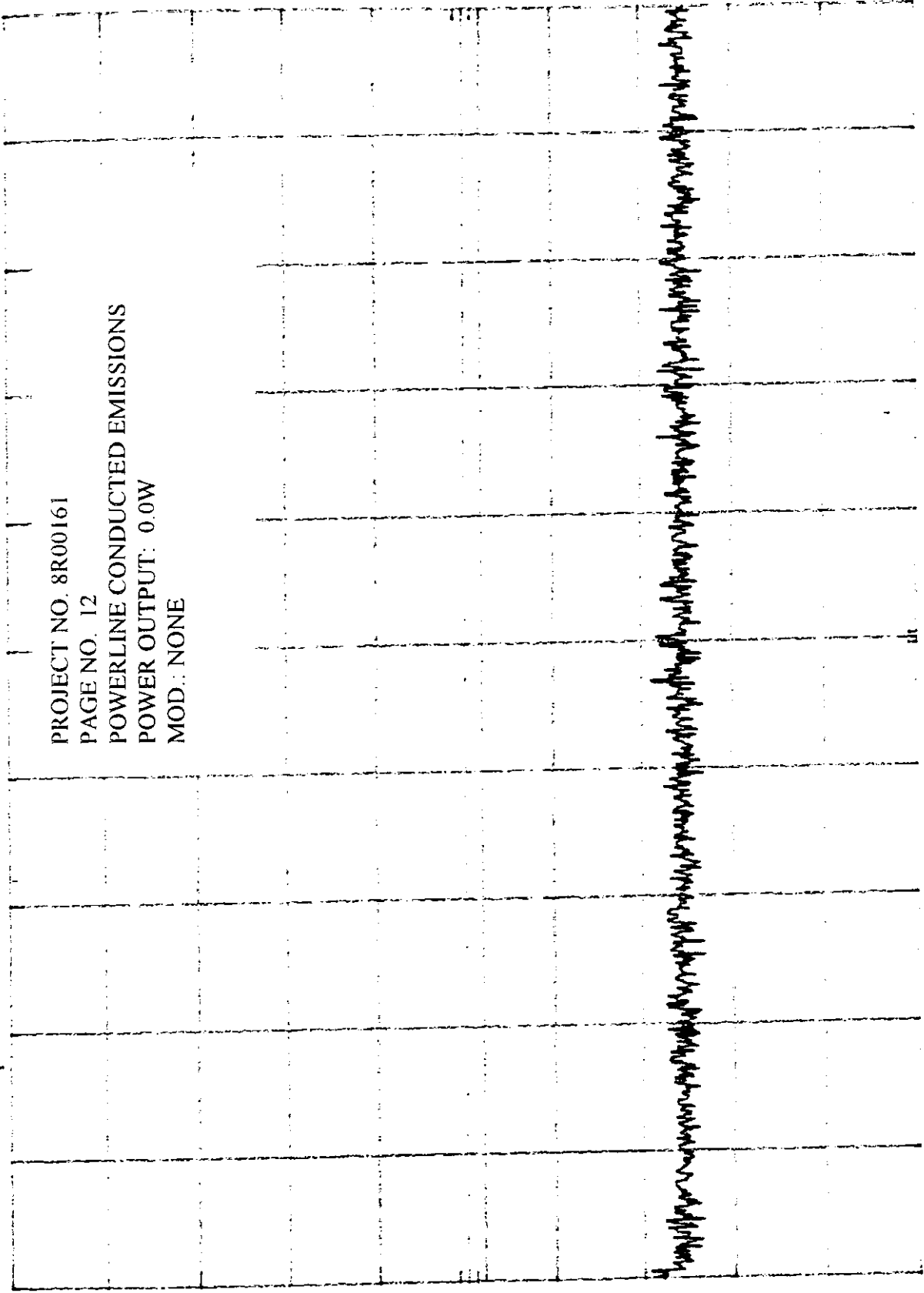

PROJECT NO. 8R00161
 PAGE NO. 12
 POWERLINE CONDUCTED EMISSIONS
 POWER OUTPUT: 0.0W
 MOD.: NONE

DL
 38.0
 dBμV

STOP 30.0 MHz
 SWP 887 msec

VBW 30 kHz

RES BW 10 kHz

START 450 kHz

EQUIPMENT: 2.4 GHz Spread Spectrum Cordless Telephone

NAME OF TEST: Radiated Emissions	PARA. NO.: 15.109(a)
TESTED BY: Kevin Carr	DATE: May 14, 1998

TEST CONDITIONS: Outdoor Range
Standard Test Voltage

MINIMUM STANDARD:

Frequency(MHz)	Field Strength(dBμV/m @3m)
30 - 88	40.0
88 - 216	43.5
216 - 960	46.0
Above 960	54.0

TEST RESULTS: Complies. The worst-case emission level is 34.8 dBμV/m@ 3m at 863.28 MHz. This is 11.2 dB below the specification limit.

MEASUREMENT DATA: See attached table.

The equipment was prescanned in a shielded room using a spectrum analyzer and broadband antenna. A list of frequencies was compiled for investigation in the open field. The equipment was then moved to an open area test site where amplitude measurements were made at a distance of 3 meters. The bandwidth was set to 120 kHz and the detector function was CISPR Quasi-Peak. Any emission within 6 dB of the specification limit is re-measured using a reference tuned dipole antenna per ANSI C63.4.

EQUIPMENT: 2.4 GHz Spread Spectrum Cordless Telephone

NAME OF TEST: Radiated Emissions	PARA. NO.: 15.109(a)
TESTED BY: Kevin Carr	DATE: May 14, 1998

TEST CONDITIONS: Outdoor Range
Standard Test Voltage

MINIMUM STANDARD: Equipment manufactured or imported before June 23, 1999 is permitted the following limits.

Frequency(MHz)	Field Strength($\mu\text{V/m}@3\text{m}$)
30 - 70	320(50.1 dB $\mu\text{V/m}$)
70 - 130	500(54.0 dB $\mu\text{V/m}$)
130 - 174	500 - 1500
174 - 260	1500(63.5 dB $\mu\text{V/m}$)
260 - 470	1500 - 5000(linear interpolation)
Above 470	5000(74.0 dB $\mu\text{V/m}$)

TEST RESULTS: Complies. The worst-case emission level is 34.8 dB $\mu\text{V/m}$ @ 3m at 863.28 MHz. This is 39.2 dB below the specification limit.

MEASUREMENT DATA: See attached table.

The equipment was prescanned in a shielded room using a spectrum analyzer and broadband antenna. A list of frequencies was compiled for investigation in the open field. The equipment was then moved to an open area test site where amplitude measurements were made at a distance of 3 meters. The bandwidth was set to 120 kHz and the detector function was CISPR Quasi-Peak. Any emission within 6 dB of the specification limit is re-measured using a reference tuned dipole antenna per ANSI C63.4.

Vertical Prescan

April 17, 1998

8r00161_2

REF 90.0 dBμV' ATTEN 0 dB

hp

10 dB/

DL

25.0

dBμV

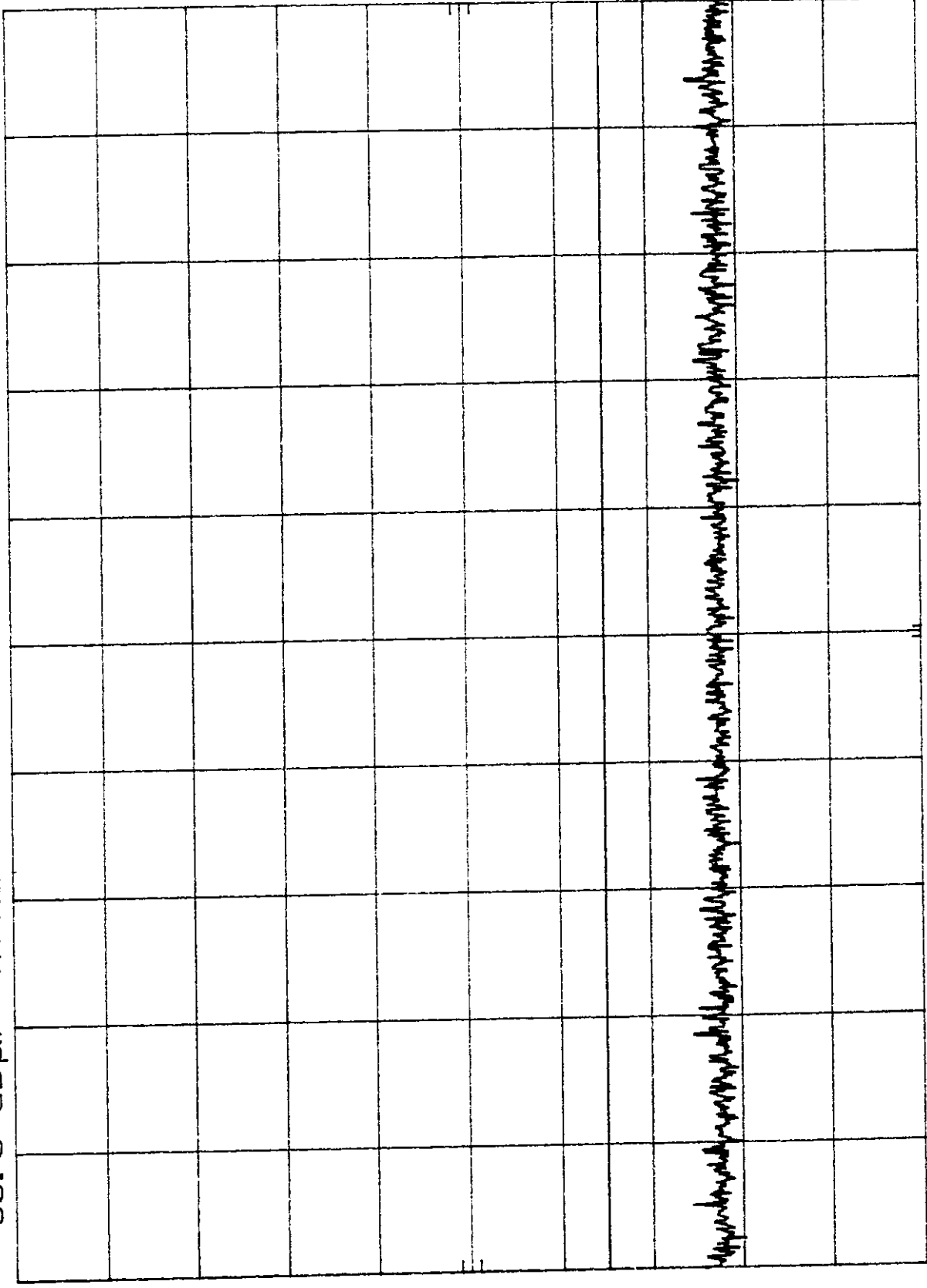

Project No.: 8R00161
Radiated Emissions
Prescans
Page No.: 16 of 22

START 30 MHz

RES BW 30 KHz

VBW 100 KHz

STOP 300 MHz

SWP 810 msec

Vertical Prescan

April 17, 1998

8r00161_2

REF 90.0 dBμV ATTEN 0 dB

hp

10 dB/

DL
20.0
dBμV

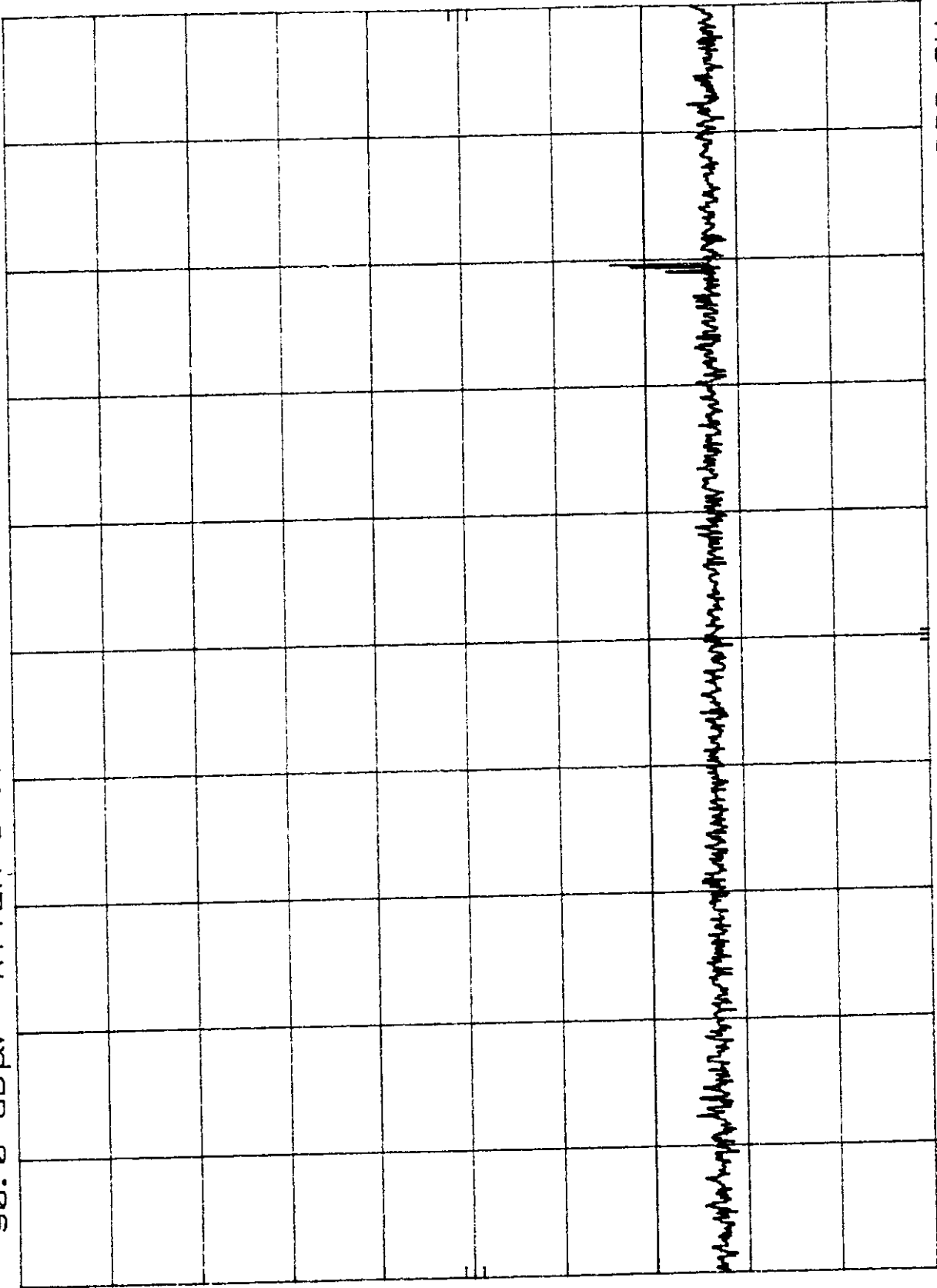

Project No.: 8R00161
Radiated Emissions
Prescans
Page No.: 17 of 22

START 300 MHz RES BW 30 KHZ VBW 100 KHZ STOP 1.000 GHz
SWP 2.10 sec

8r00161_2 April 17, 1998 Horizontal Prescan

HP REF 90.0 dBμV' ATTEN 0 dB

HP

10 dB/

DL
25.0
dBμV

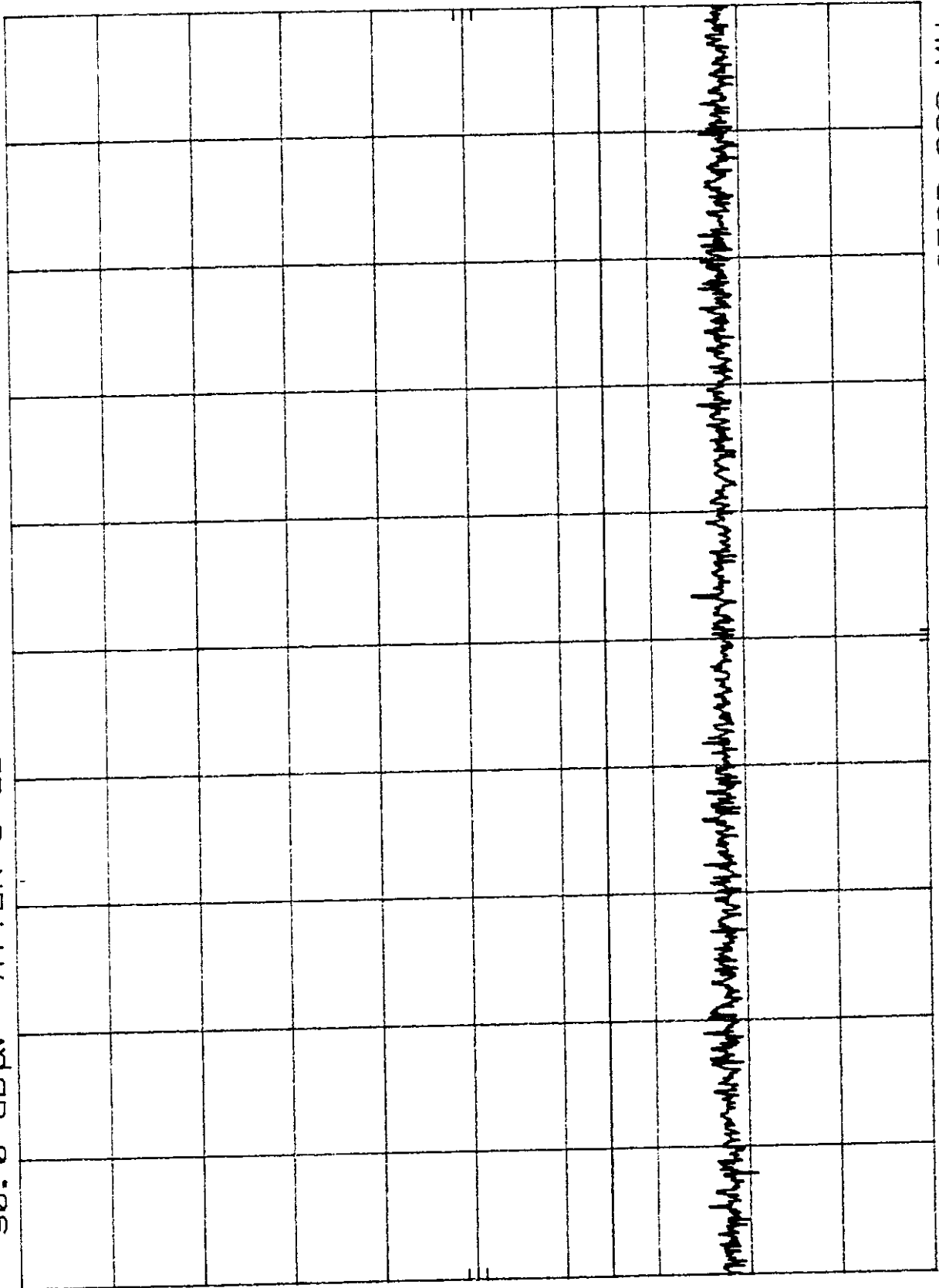

START 30 MHz RES BW 30 KHz VBW 100 KHz STOP 300 MHz
 SWP 810 msec

8r00161_2 April 17, 1998 Horizontal Prescans

hp REF 90.0 dBµV, ATTEN 0 dB

10 dB/

20.0

DL
20.0
dBµV

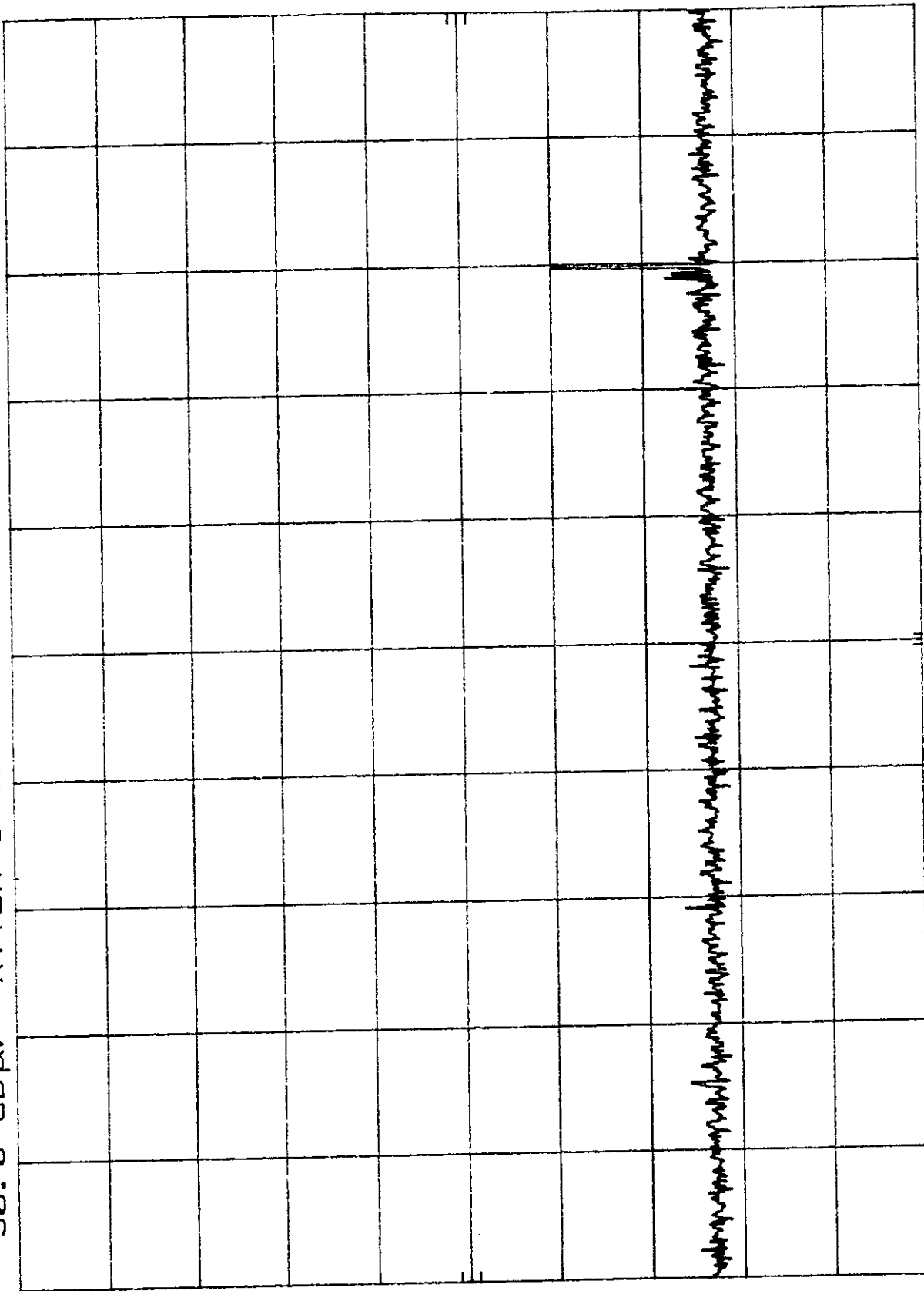

Project No.: 8R00161
Radiated Emissions
Prescans
Page No.: 19 of 22

STOP 1.000 GHz
SWP 2.10 sec

RES BW 30 KHZ
VBW 100 KHZ

STOP 1.000 MHz

EQUIPMENT: 2.4 GHz Spread Spectrum Cordless Telephone

Prescan Data

Project Number : 8r00161_2
Project Filename : 8R1612B.LST
Date : April 17, 1998
Start Frequency : 30 MHz
Stop Frequency : 1000 MHz
Display Line Value: 25 (30-300 MHz), 20 (300-1000MHz) dBuV

Vertical Prescan

Top Emissions below 300 MHz from the vertical prescan list:

Full Emission List below 300 MHz:

Top Emissions above 300 MHz from the vertical prescan list:

Full Emission List above 300 MHz:

Horizontal Prescan

Top Emissions below 300 MHz from the horizontal prescan list:

Full Emission List below 300 MHz:

Top Emissions above 300 MHz from the horizontal prescan list:

Full Emission List above 300 MHz:

EQUIPMENT: 2.4 GHz Spread Spectrum Cordless Telephone

BLOCK DIAGRAMS
POWERLINE CONDUCTED EMISSIONS

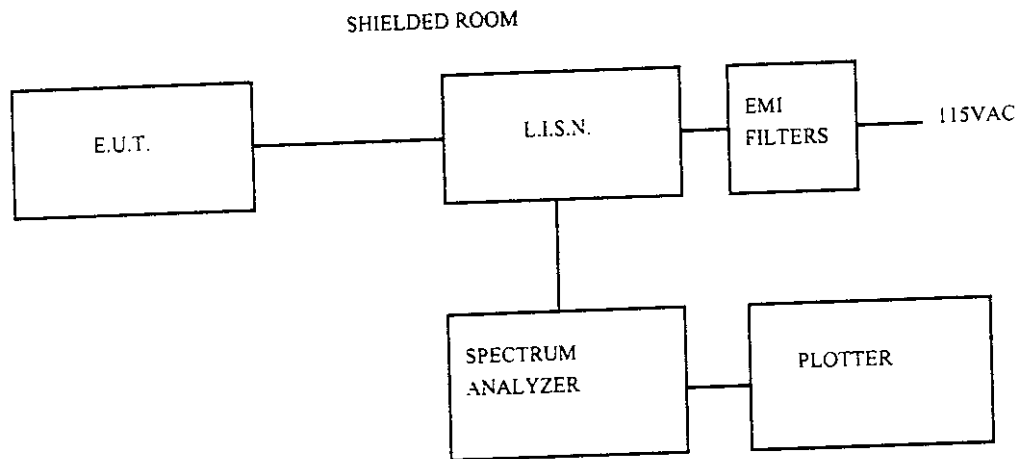

TEST SITE FOR RADIATED EMISSIONS

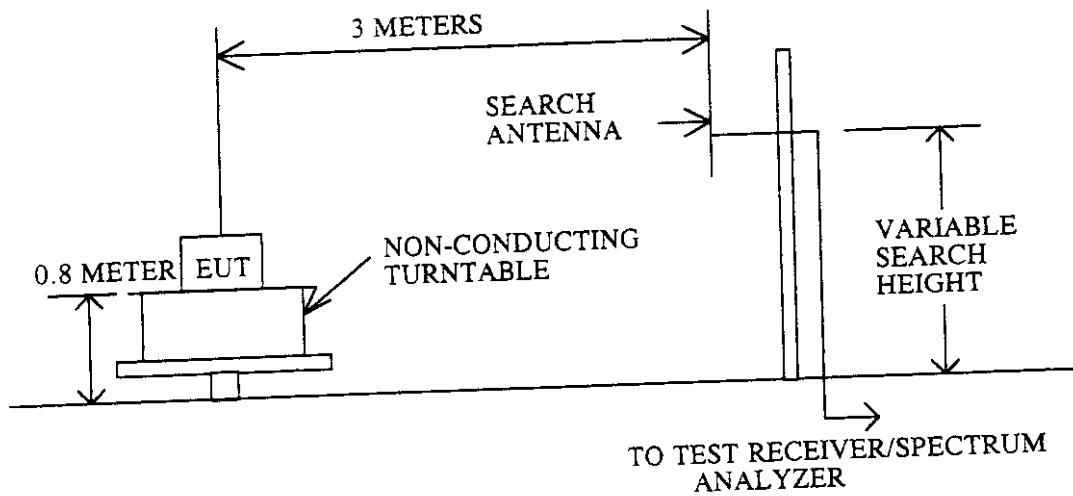

For Super Regenerative Receivers the receiver was activated using a tuned dipole antenna fed with a CW signal. The frequency of the activating signal is adjusted to obtain worst-case field strength of the EUT oscillator emission.

The spectrum was searched to the 10th harmonic of the fundamental frequency.

EQUIPMENT: 2.4 GHz Spread Spectrum Cordless Telephone

TEST EQUIPMENT LIST

Equipment List - Conducted Emissions - Shielded Room #2

CAL Cycle	Equipment	Manufacturer	Model #	Serial/Asset #	Last Cal.	Next Cal.
1Year	LISN	Tegam	95300-50	T-128556	July 24/97	July 24/98
	Plotter	Hewlett-Packard	7470A	2210A08836	N/A	N/A

Equipment List - Radiated Emissions

CAL Cycle	Equipment	Manufacturer	Model #	Serial/Asset #	Last Cal.	Next Cal.
	Biconilog Antenna	EMCO	3143	9404-1039	NCR	NCR
1Year	Receiver	Rohde & Schwarz	ESVP	892661/014	Mar. 31/98	Mar. 31/99
1 Year	Biconical (1) Antenna	EMCO	3109	9204-2708	July 11/97	July 11/98
2 Year	Horn Antenna	EMCO	3115	4336	Oct. 30/97	Oct. 30/99
1 Year	Log Periodic Antenna	EMCO	LPA-25	1141	July 10/97	July 10/98

Note: N/A = Not Applicable
 NCR = No Cal Required



Panasonic Model KX-TG210 Series
900 MHz / 2.4 GHz Spread Spectrum Cordless Telephone System
FCC ID: ACJ96NKX-TG210

Certelec Laboratories Inc.

Safety - EMI - Telecom - ISO Guide 25

ENGINEERING TEST REPORT

ON:

THE PANASONIC CANADA INC.

"2.4 GHz SPREAD SPECTRUM CORDLESS TELEPHONE BASE"

IN ACCORDANCE WITH:

FCC PART 15, SUBPART C

DIRECT SEQUENCE TRANSMITTERS

2400 - 2483.5 MHz

PROJECT NO.: 8R00161.1

TESTED FOR:

PANASONIC CANADA INC.
5770 AMBLER DRIVE
MISSISSAUGA, ONTARIO
L4W 2T3

TESTED BY:

CERTELECOM LABORATORIES INC.
3325 RIVER ROAD, R.R. 5
OTTAWA, ONTARIO K1V 1H2

MAY 1998

This document contains 53 pages including this one.

Certelec Laboratories Inc. authorizes the above named company to reproduce this report provided it is reproduced in its entirety and for use by the company's employees only.

Any use which a third party makes of this report, or any reliance on or decisions to be made based on it, are the responsibility of such third parties. Certelec Laboratories Inc. accepts no responsibility for damages, if any, suffered by any third party as a result of decisions made or actions based on this report.

This report applies only to the items tested.

EQUIPMENT: 2.4 GHz Spread Spectrum Cordless Telephone Base

EQUIPMENT DESCRIPTION:

MODEL NO.: KX-TG210

SERIAL NO.: None

GENERAL:

These tests were conducted on a sample of the equipment for the purpose of demonstrating compliance with Part 15, Subpart C Paragraph 15.247 for Direct Sequence Spread Spectrum devices.

ABSTRACT:

Based on the data contained in this report, the E.U.T. complies with the standards set forth in FCC Part 15.247 for direct sequence transmitters.

THIS TEST REPORT RELATES ONLY TO THE ITEM(S) TESTED.

THE FOLLOWING DEVIATIONS FROM, ADDITIONS TO, OR EXCLUSIONS FROM THE TEST SPECIFICATIONS HAVE BEEN MADE. - None

TESTED BY: *Kevin Carr*
Kevin Carr, Technologist

DATE: 02 June 1998

APPROVED BY: *Tom Tidwell*
Tom Tidwell, Senior Technologist

DATE: 02 JUNE 1998

EQUIPMENT: 2.4 GHz Spread Spectrum Cordless Telephone Base

SUMMARY OF TEST DATA

NAME OF TEST	PARA. NO.	SPEC.	MEAS.	RESULT
Powerline Conducted Emissions	15.207(a)	48 dB μ V	20 dB μ V	Complies
Occupied Bandwidth	15.247(a)(2)	\geq 500kHz	1.6 MHz	Complies
Peak Power Output	15.247(b)	1 watt	3.98 dBm	Complies
Spurious Emissions (Band Edge Antenna Radiated)	15.247(c)	-20 dBc	Plot	Complies
Spurious Emissions (Radiated)	15.247(c)	Table 15.209(a)	Chart	Complies
Transmitter Power Density	15.247(d)	\leq +8 dBm	-16.1 dBm	Complies
Processing Gain	15.247(e)	\geq 10 dB	Cust. Data	Complies

FOOTNOTES FOR N/A'S:

EQUIPMENT: 2.4 GHz Spread Spectrum Cordless Telephone Base

GENERAL EQUIPMENT SPECIFICATION
TRANSMITTER

Power Input:	12 Vdc via AC Adaptor
Frequency Range:	2402.8 MHz to 2481.44 MHz (BASE UNIT)
Tunable Bands:	1
Necessary Bandwidth:	500 kHz
6 dB Bandwidth:	1.6 MHz
Type of Modulation:	Direct Sequence, Spread Spectrum
Emission Designator:	F1D
Link AGC:	NORMAL MODE : 0.0025W (3.98dBm)
RF Power Output (rated):	HIGH MODE : 0.1W (20.1dBm)
Channel Spacing:	2.56 MHz
Operator Selection of Operating Frequency:	Software Controlled

EQUIPMENT: 2.4 GHz Spread Spectrum Cordless Telephone Base

GENERAL EQUIPMENT SPECIFICATION
RECEIVER

Frequency Range:	909.64 MHz to 920.80 MHz
Tunable Bands:	1
Type of modulation:	Direct Sequence Spread Spectrum
Operator Selection of Operating Frequency:	Software Controlled

EQUIPMENT: 2.4 GHz Spread Spectrum Cordless Telephone Base

NAME OF TEST: Powerline Conducted Emissions	15.207(a)
TESTED BY: Kevin Carr	DATE: April 17, 1998

TEST RESULTS: Complies. See attached graph.

MEASUREMENT DATA: See attached graph.

8r00161_2 April 17, 1998 Neutral

10dB Limiter used
REF 90.0 dBµV ATTN 10 dB

hp

10 dB/

PROJECT NO. 8r00161.1

PAGE NO. 8

POWERLINE CONDUCTED EMISSIONS

POWER OUTPUT: 0.0 W

MOD: NONE

DL
38.0
dBµV

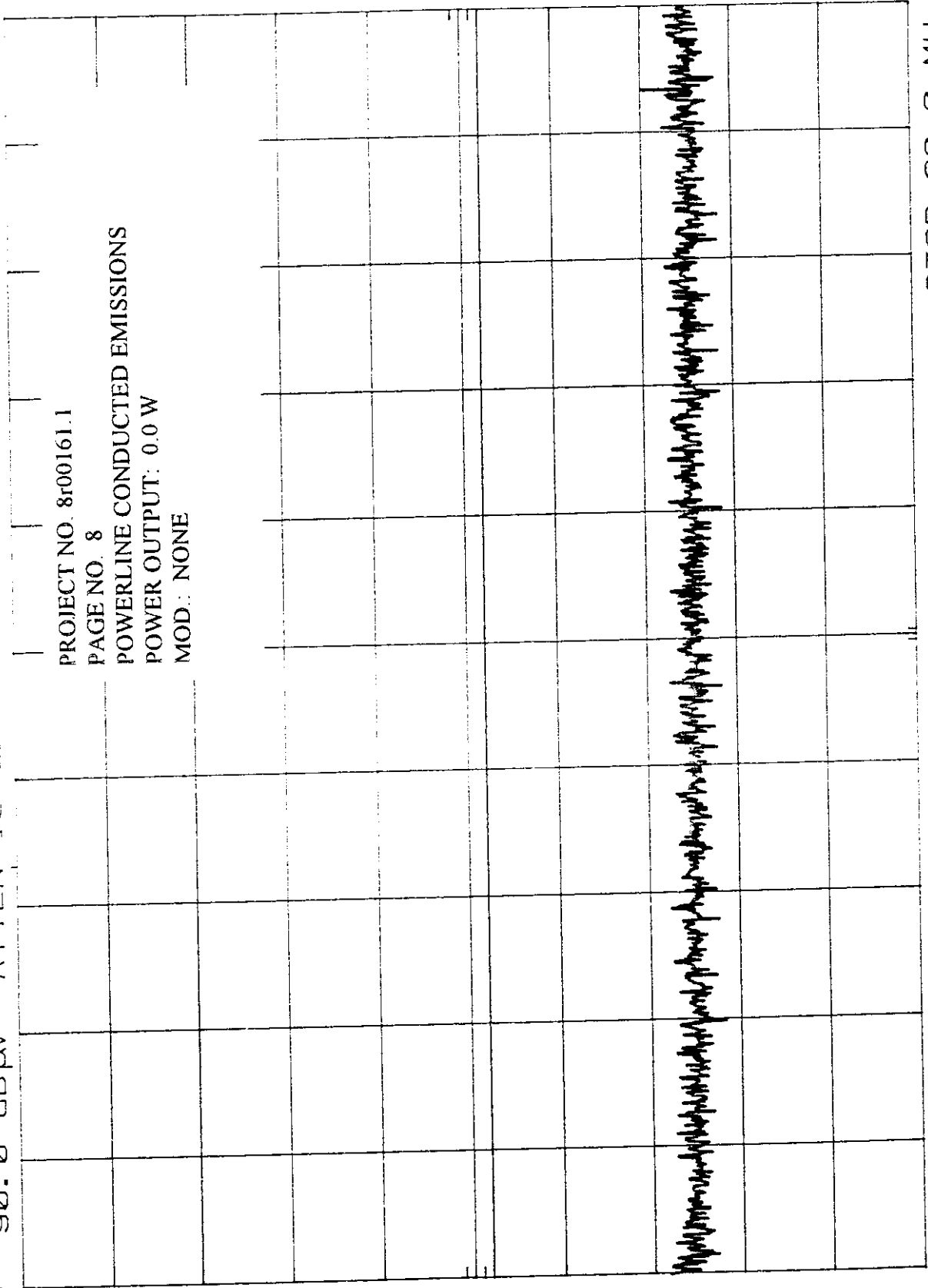

START 450 KHZ
RES BW 10 KHZ

VBW 30 KHZ

STOP 30.0 MHz
SWP 887 msec

Phase

Apr 11 17. 1998

8r00161_2 10dB Limiter used
REF 90.0 dBμV ATTEN 10 dB

hp

10 dB/

PROJECT NO. 8r00161.1
PAGE NO. 9
POWERLINE CONDUCTED EMISSIONS
POWER OUTPUT: 0.0 W
MOD.: NONE

DL
38.0
dBμV

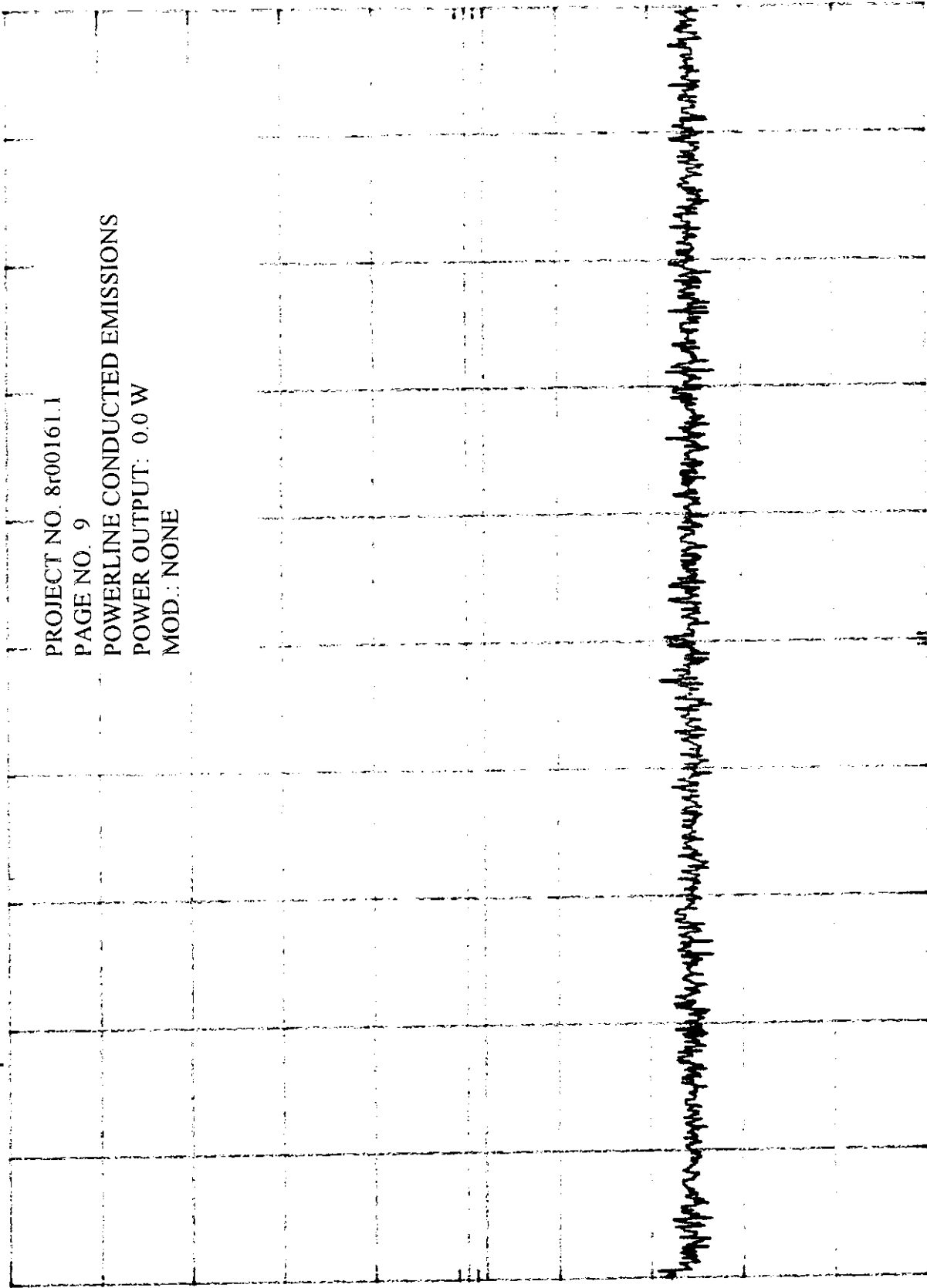

START 450 KHZ

RES BW 10 KHZ

VBW 30 KHZ

STOP 30.0 MHz

SWP 887 msec

EQUIPMENT: 2.4 GHz Spread Spectrum Cordless Telephone Base

NAME OF TEST: Occupied Bandwidth	PARA. NO.: 15.247(a)(2)
TESTED BY: Kevin Carr	DATE: April 27, 1998

TEST RESULTS: Complies. The 6 dB bandwidth is 1.6 MHz. See attached graph.

MEASUREMENT DATA: See attached graph.

ATTEN 10dB

RL -55.4dBm

2dB

MKA - .23dB

1.633MHz

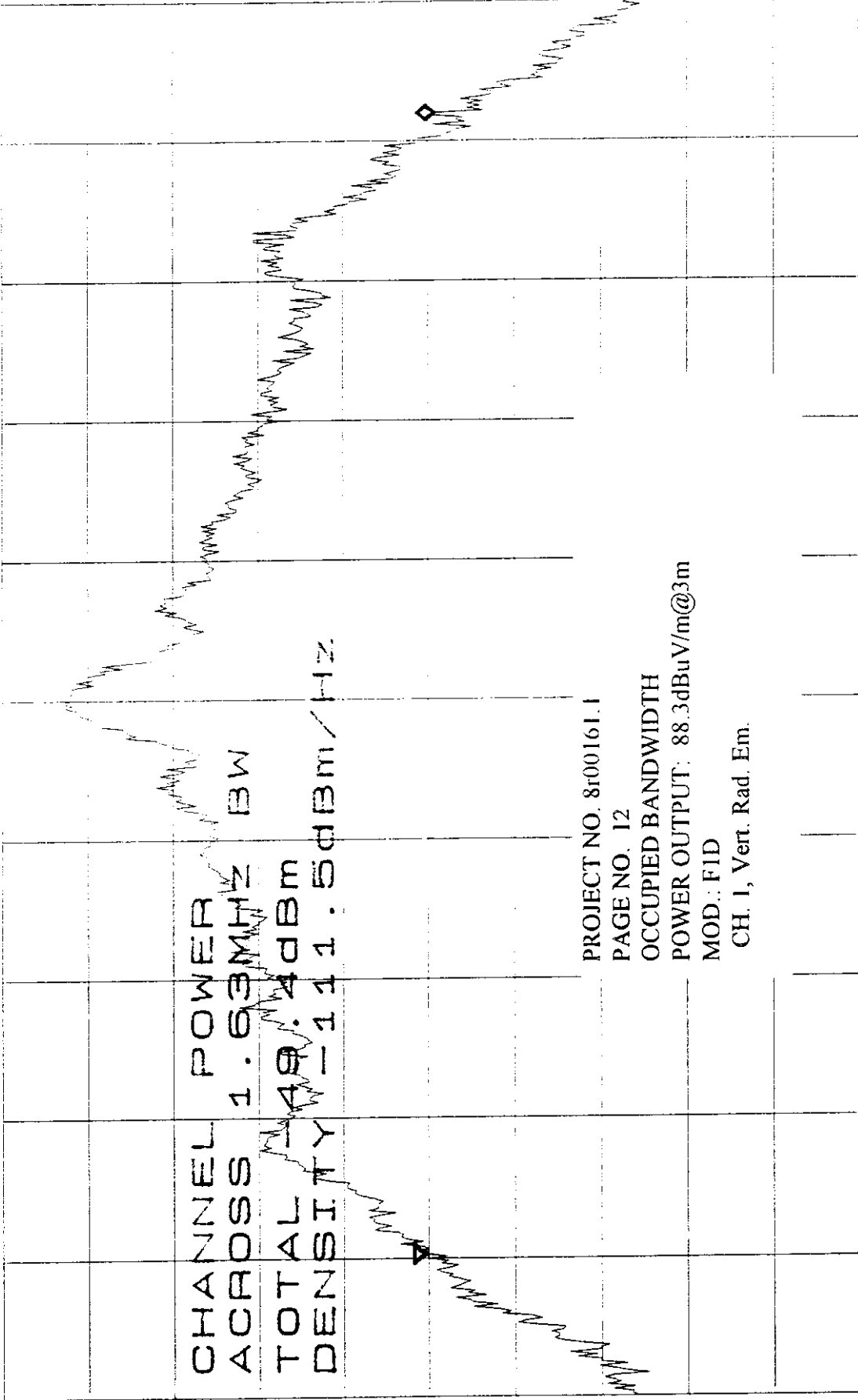

CHANNEL POWER
 ACROSS 1.63MHz BW
 TOTAL -49.4dBm
 DENSITY -111.5dBm/Hz

PROJECT NO. 8r00161.1

PAGE NO. 12

OCCUPIED BANDWIDTH

POWER OUTPUT: 88.3dBuV/m@3m

MOD.: FID

CH. 1, Vert. Rad. Em.

CENTER 2.402077GHz

SPAN 2.000MHz

*RBW 100kHz

VBW 100kHz

SWP 50.0ms

*ATTEN 0dB

RL -46.2dBm

MKR 0dB

1.260MHz

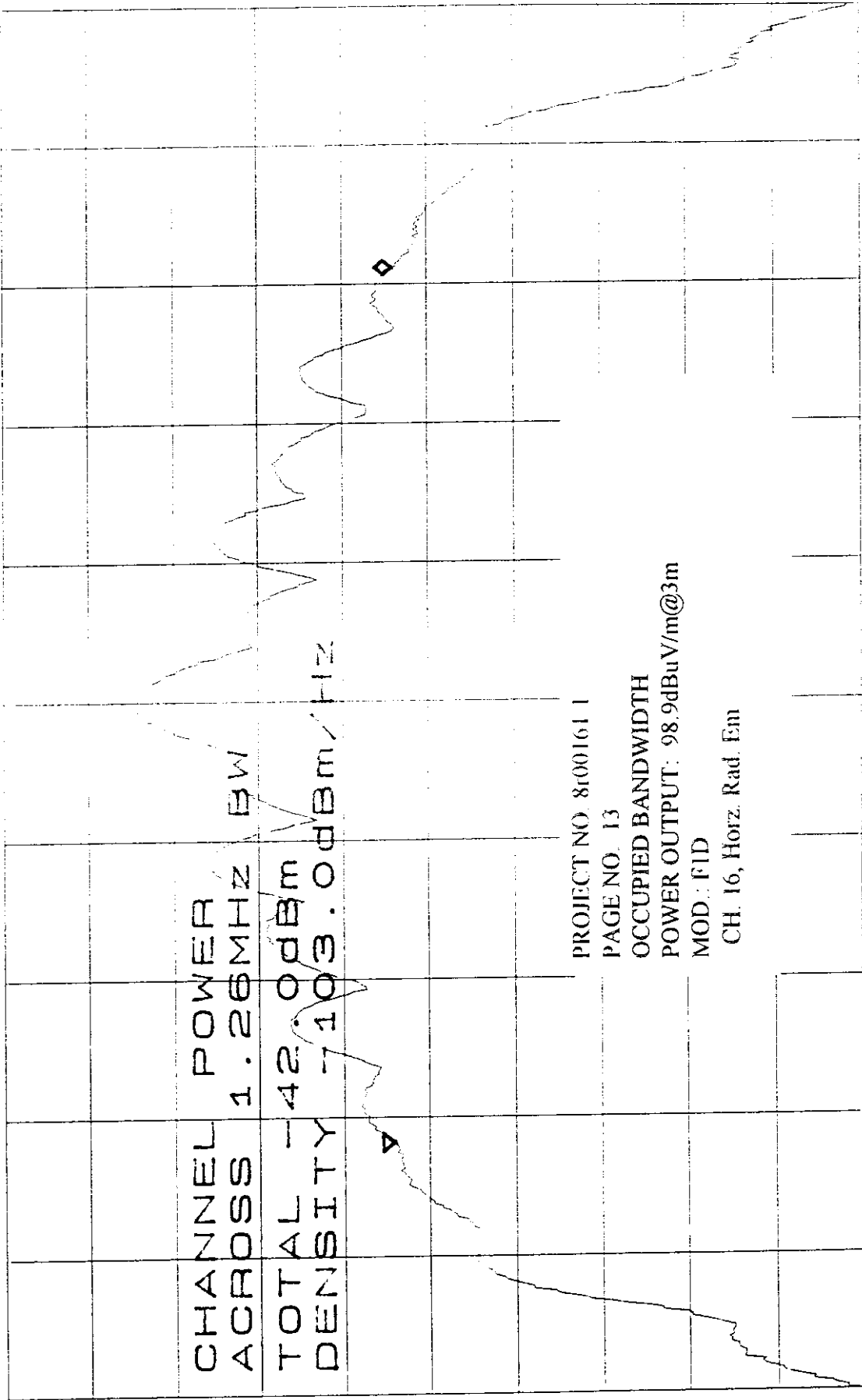

D

CENTER 2.440477GHz

SPAN 2.000MHz

*RBW 100kHz

VBW 100kHz

SWP 50.0ms

*ATTEN 0dB MKR .04dB

RL -50.0dBm 1.427MHz

2dB

*ATTEN 0dB

RL -50.0dBm

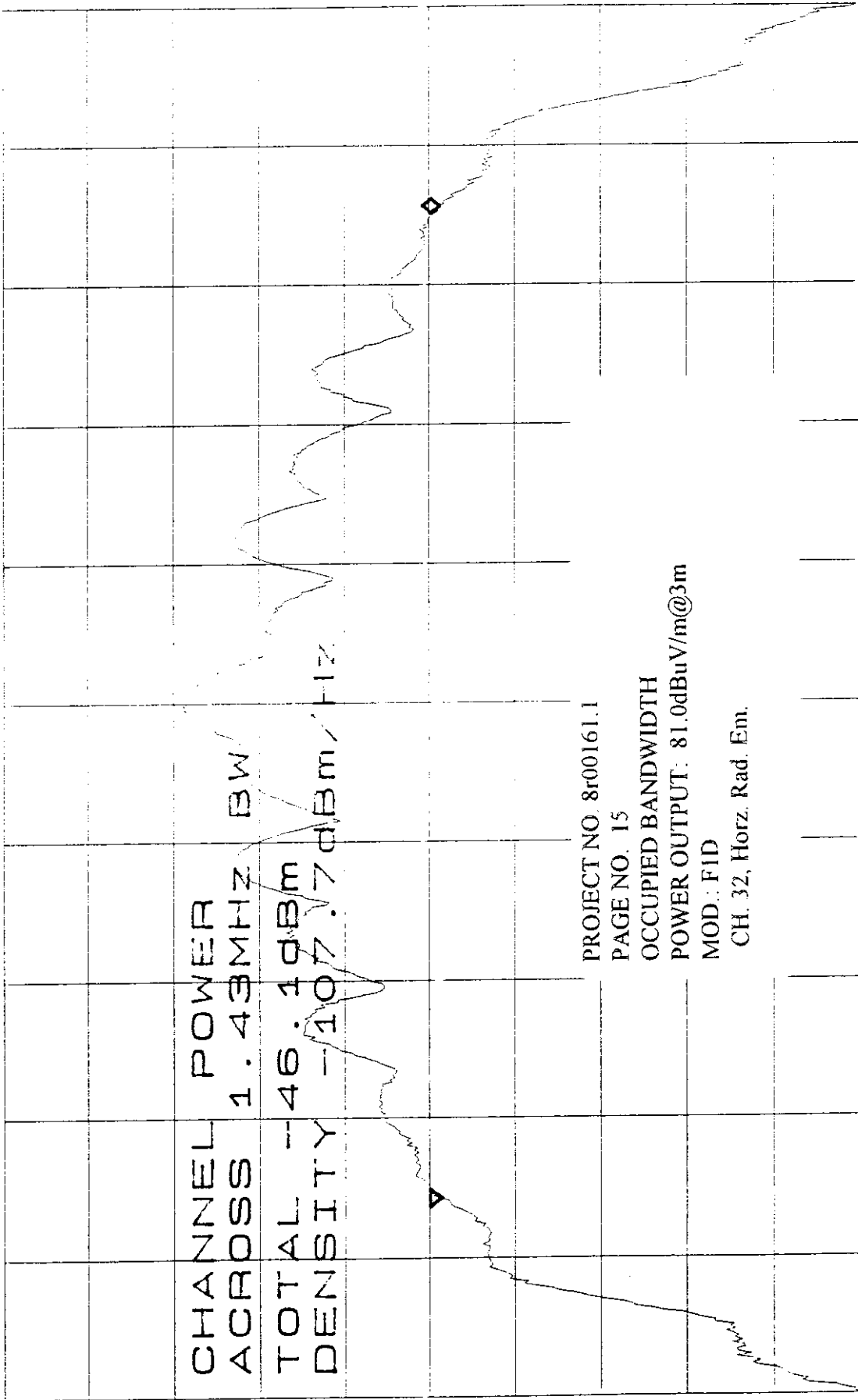

PROJECT NO. 8r00161.1

PAGE NO. 15

OCCUPIED BANDWIDTH

POWER OUTPUT: 81.0dBuV/m@3m

MOD.: FID

CH. 32, Horz. Rad. Em.

CENTER 2.481437GHz

SPAN 2.000MHz

*RBW 100kHz

VBW 100kHz

SWP 50.0ms

ATTEN 10dB ,

RL -48.3dBm

2dB/

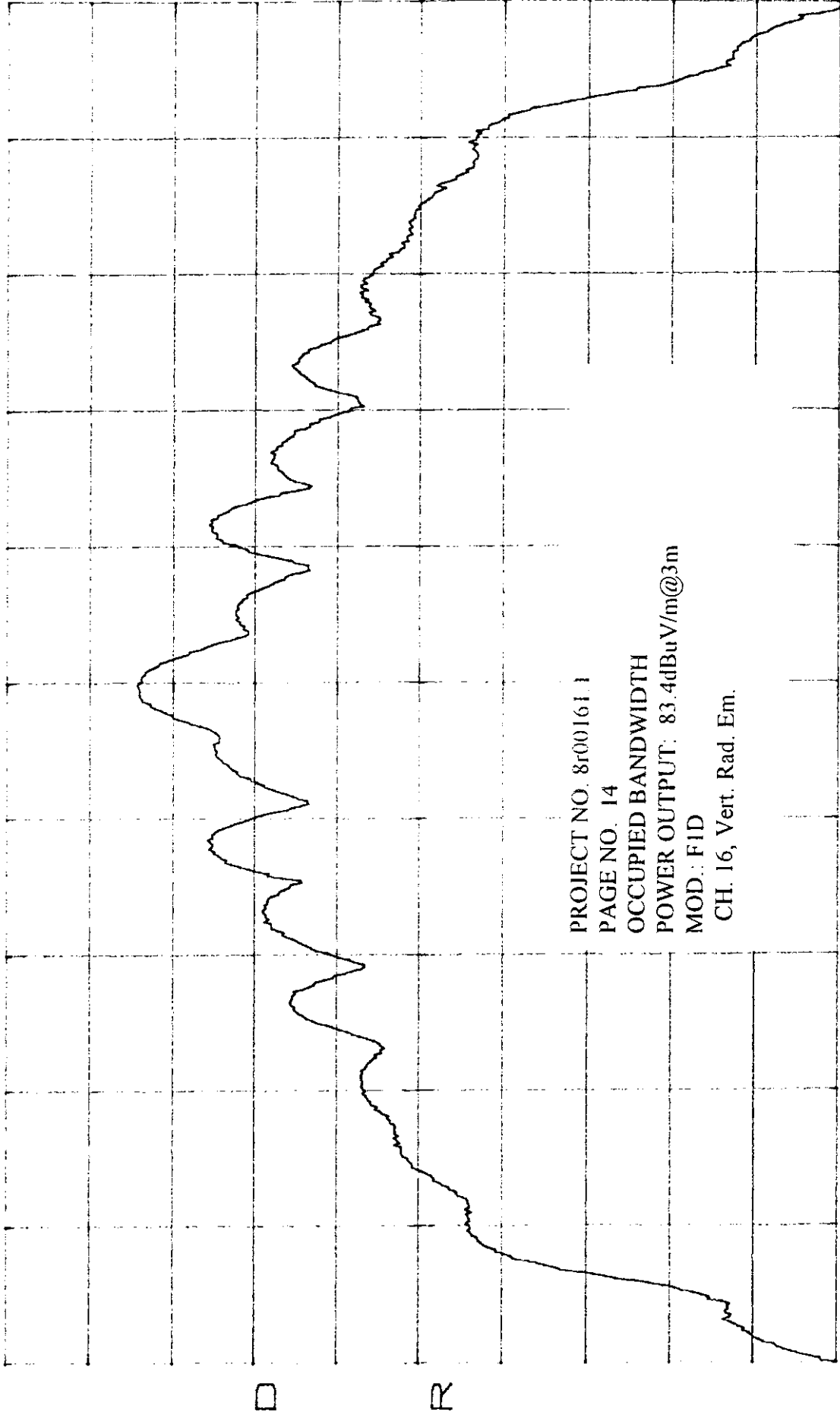

PROJECT NO. 8r001611

PAGE NO. 14

OCCUPIED BANDWIDTH

POWER OUTPUT: 83.4dBuV/m@3m

MOD: FID

CH. 16, Vert. Rad. Em.

CENTER 2.440480GHZ

SPAN 2.000MHZ

*RBW 100KHZ

VBW 100KHZ

SWP 50.0ms

*ATTEN 0dB

RL -57.1dBm

2dB/

MKA - .13dB

1.440MHZ

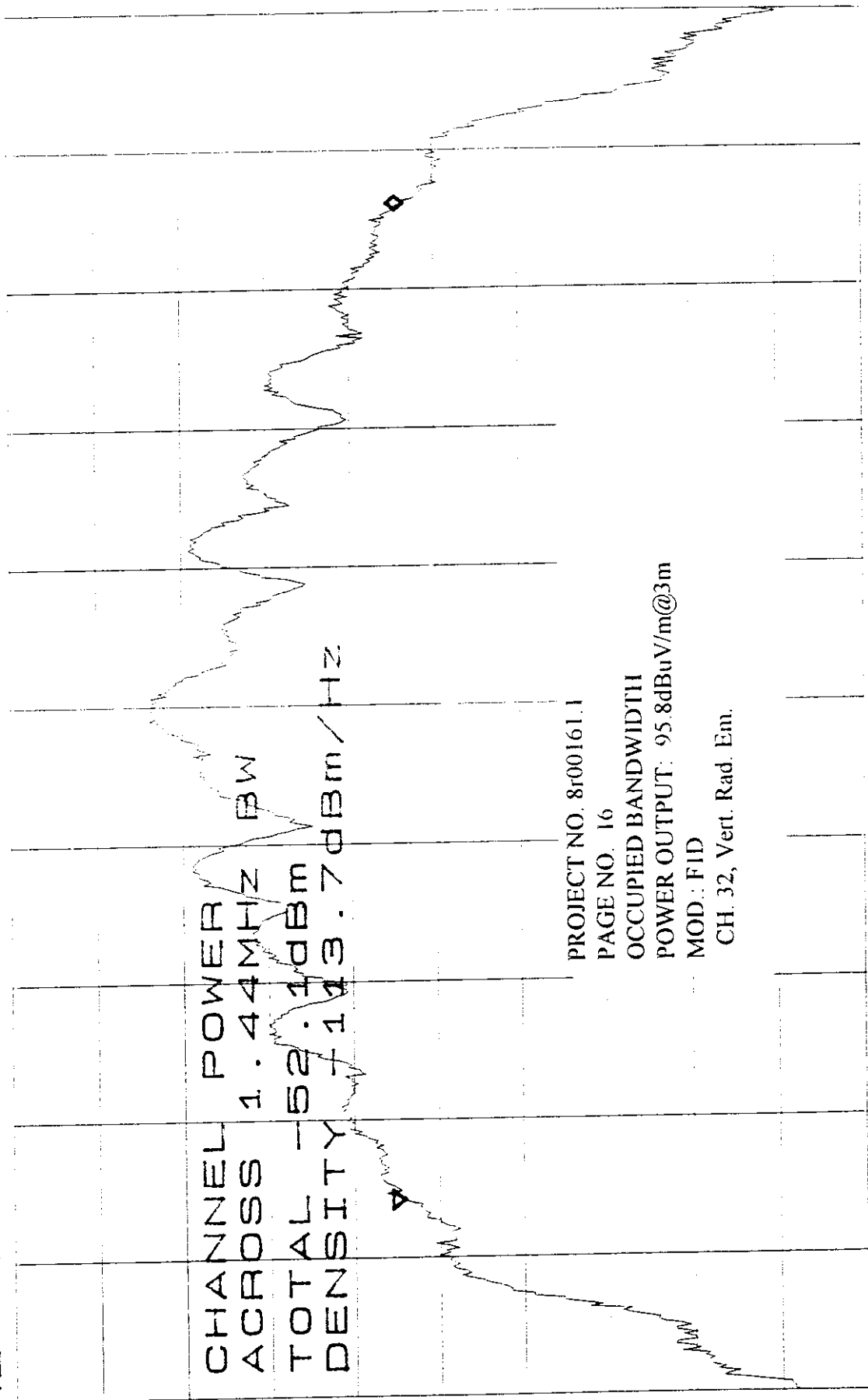

CHANNEL POWER
 ACROSS 1.44MHZ BW
 TOTAL -52.1dBm
 DENSITY -113.7dBm/HZ

PROJECT NO. 8r00161.1

PAGE NO. 16

OCCUPIED BANDWIDTH

POWER OUTPUT: 95.8dBuV/m@3m

MOD.: FID

CH. 32, Vert. Rad. Em.

CENTER 2.481440GHZ

SPAN 2.000MHZ

*RBW 100KHZ

VBW 100KHZ

SWP 50.0ms

EQUIPMENT: 2.4 GHz Spread Spectrum Cordless Telephone Base

NAME OF TEST: <u>Peak Power Output</u>	PARA. NO.: 15.247(b)
TESTED BY: Kevin Carr	DATE: May 20, 1998

TEST RESULTS: Complies. The maximum peak power output of the transmitter is 0.0025 watts.

MEASUREMENT DATA:

Detachable antenna? yes no

If yes, state the type of non-standard connector used at the antenna port:

Directional Gain of antenna: 0 dBi or 1 Numeric(dBi/10)

Peak Power Output: 0.0025 watts

Field Strength: 99.2 dB μ V/m @ 3m or 0.0912 V/m @ 3m.

$$\text{Log}^{-1}\left(\frac{99.2 \text{ dB}\mu\text{V}}{20}\right) = 91.2 \text{ mV}$$

$$\text{EIRPs} \left(\frac{91.2 \text{ mV}}{30}\right)^2 \times 9 = 2.50 \text{ mW}$$
$$= 3.98 \text{ dBm}$$

EQUIPMENT: 2.4 GHz Spread Spectrum Cordless Telephone Base

NAME OF TEST: Band Edge (Antenna Radiated)	PARA. NO.: 15.247(c)
TESTED BY: Kevin Carr	DATE: April 27, 1998

TEST RESULTS: Complies. The worst-case emission level is 23.3 dBc at 2399.4 MHz. This is 3.3 dB below the specification limit.

MEASUREMENT DATA: See attached graphs.

For the worst case radiated emission the difference in antenna factors between 2.6 and 2.4 GHz is 0.7 dB.

*ATTEN 0dB

RL -41.0dBm

10dB/

10dB/

MKR --81.67dBm

2.399408GHZ

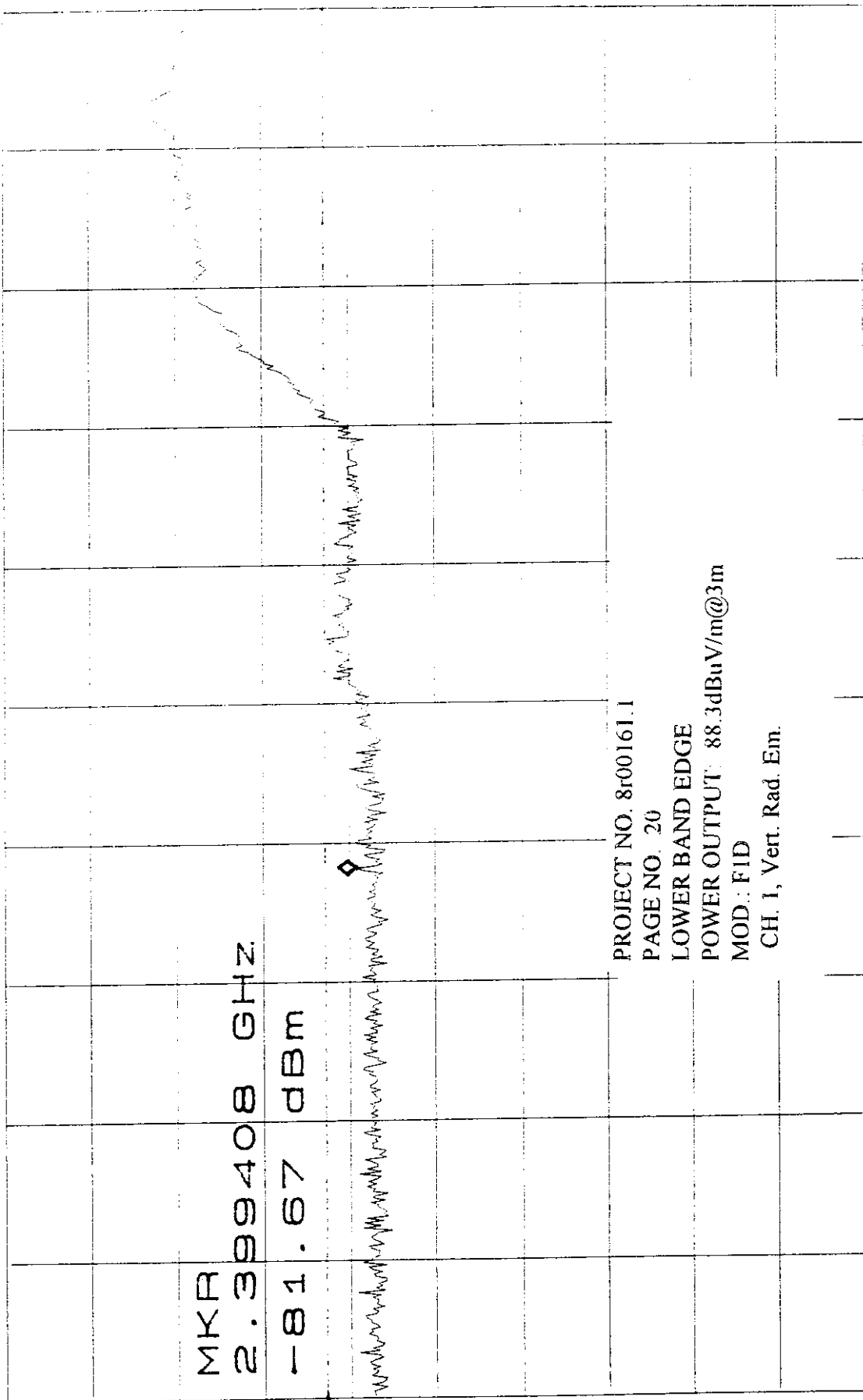

MKR
 2.399408 GHZ
 -81.67 dBm

PROJECT NO. 8r00161.1
 PAGE NO. 20
 LOWER BAND EDGE
 POWER OUTPUT: 88.3dBuV/m@3m
 MOD: FID
 CH. 1, Vert. Rad. Em.

CENTER 2.400000GHZ SPAN 5.000MHZ
 *RBW 100KHZ *VBW 300KHZ SWP 50.0ms

*ATTEN 0dB MKR -75.23dBm

RL -26.9dBm 10dB/ 2.398917GHZ

DISPLAY LINE
-65.0 dBm

D

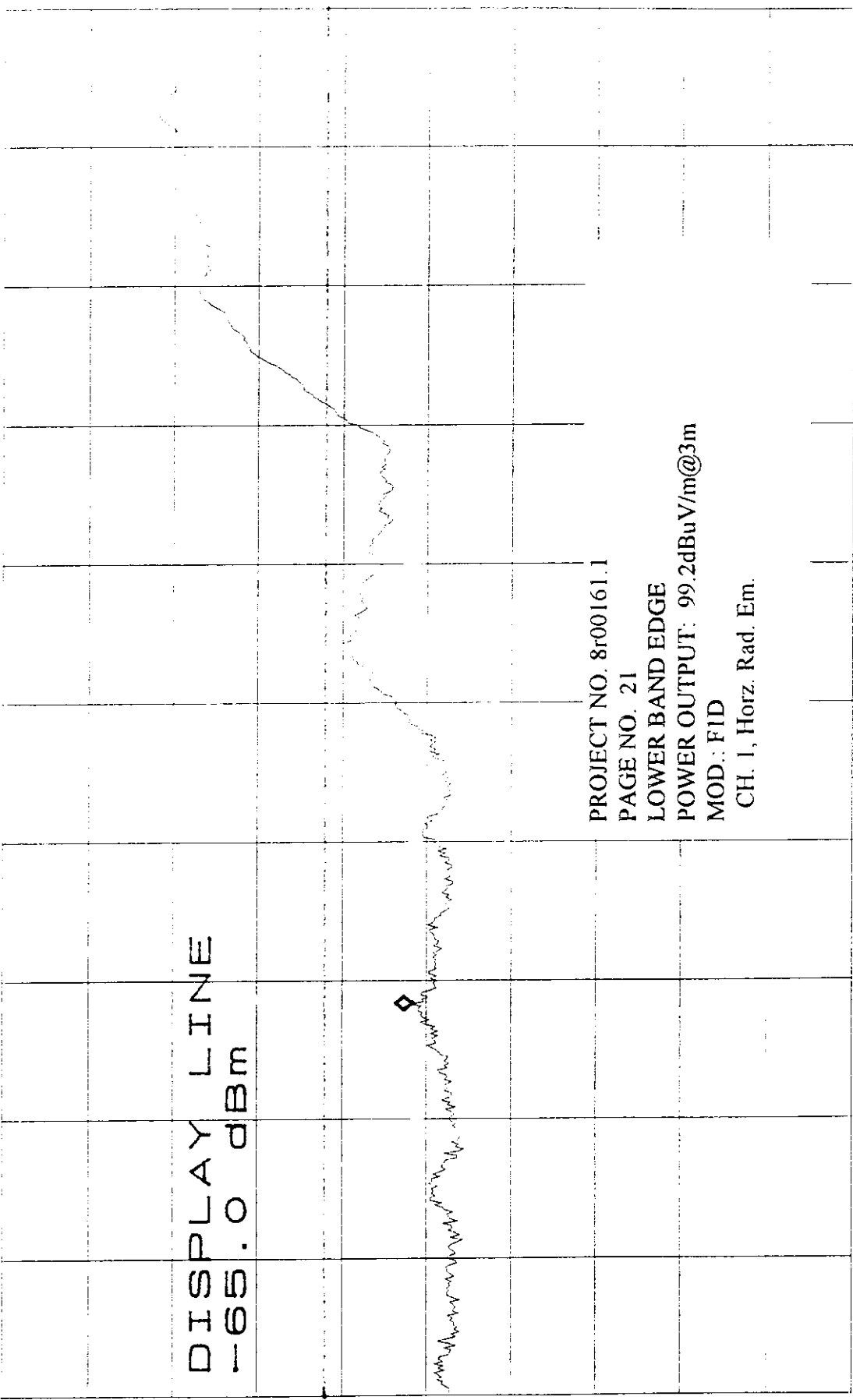

PROJECT NO. 8r00161.1
 PAGE NO. 21
 LOWER BAND EDGE
 POWER OUTPUT: 99.2dBuV/m@3m
 MOD.: FID
 CH. 1, Horz. Rad. Em.

CENTER 2.400000GHZ SPAN 5.000MHZ
 *RBW 100KHZ *VBW 300KHZ SWP 50.0ms

*ATTEN 0dB , MKR -81.70dBm
RL -33.7dBm 10dB/ 2.484742GHZ

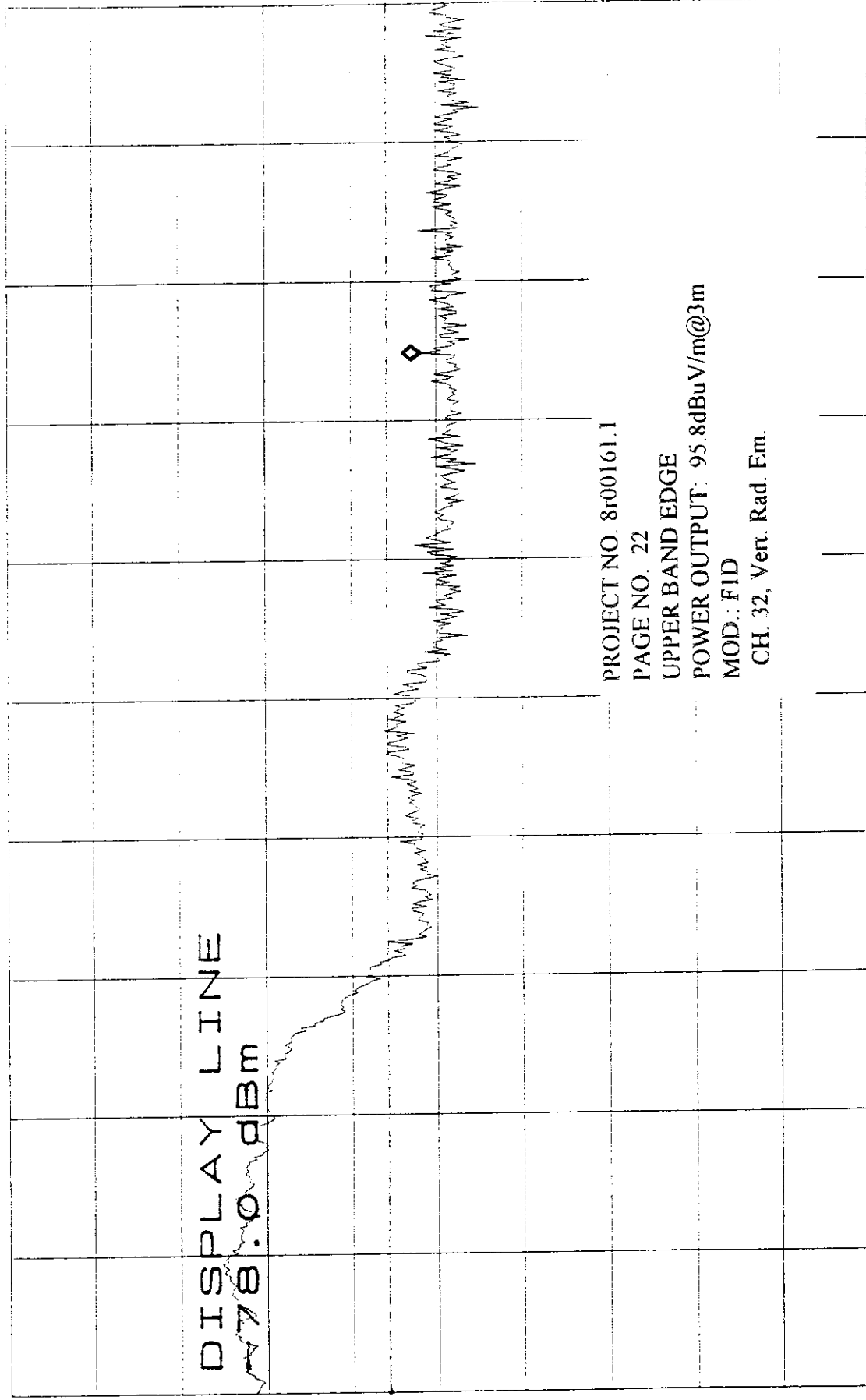

CENTER 2.483500GHZ SPAN 5.000MHZ
*RBW 100KHZ *VBW 300KHZ SWP 50.0ms

KTL - Certelecom Laboratories Inc.

**FCC PART 15, SUBPART C
DIRECT SEQUENCE TRANSMITTERS
PROJECT NO.: 8R00161.1**

EQUIPMENT: 2.4 GHz Spread Spectrum Cordless Telephone Base

Test Data - Radiated Emissions (PEAK)

Test Distance (meters): 3		Range: A Tower		Receiver: HP8566B		RBW: 1 MHz VBW: 1 MHz		PEAK			
Standard: FCC Part 15, Subpart C			E.U.T. Model No.: KX-TG210 Base			Date: May 20, 1998		Tested By: Kevin Carr			
Freq. (MHz)	Ant.	Pol. (V/H)	Ant. HGT. (m)	Table (deg)	RCVD Signal (dBµV/m)	Ant. Factor (dB)	Amp. Gain (dB)	Ant. Corr. (dB)	Field Strength (dBµV/m)	Limit	Margin (dB)
Channel 1											
4804.2	Horn2	V			47.7	40.8	-46.0	20	62.5	74.0	11.5
4804.2	Horn2	H			54.8	40.8	-46.0	20	69.6	74.0	4.4
7206	Horn2	V			45.4	46.2	-45.8	20	65.8	79.2	13.4
7206	Horn2	H			49.7	46.2	-45.8	20	66.1	79.2	13.1
9608.8	Horn2	V			44.7	51.4	-43.9		52.2	79.2	27.0
9608.8	Horn2	H			44.5	51.4	-43.9		52.0	79.2	27.2
12010.0	Horn2	V			44.6	55.0	-44.0		55.6	74.0	18.4
12010.0	Horn2	H			44.1	55.0	-44.0		55.1	74.0	18.9
Channel 16											
4881.0	Horn2	V			46.9	41.1	-46.0	20	62.0	74.0	12.0
4881.0	Horn2	H			50.7	41.1	-46.0	20	65.8	74.0	8.2
7321.5	Horn2	V			46.9	46.4	-45.7	20	67.6	74.0	6.4
7321.5	Horn2	H			45.6	46.4	-45.7	20	66.3	74.0	7.7
9762.0	Horn2	V			44.1	51.6	-44.4		51.3	79.2	27.9
9762.0	Horn2	H			44.6	51.6	-44.4		51.8	79.2	27.4
12202.5	Horn2	V			45.1	55.8	-44.3		56.6	74.0	17.4
12202.5	Horn2	H			45.0	55.8	-44.3		56.5	74.0	17.5
Channel 32											
4963.2	Horn2	V			46.4	41.4	-46.0	20	61.8	74.0	12.2
4963.2	Horn2	H			47.0	41.4	-46.0	20	62.4	74.0	11.6
7444.5	Horn2	V			45.2	46.6	-45.6	20	66.2	74.0	7.8
7444.5	Horn2	H			44.6	46.6	-45.6	20	65.6	74.0	8.4
9926.0	Horn2	V			44.3	51.8	-44.0		52.1	79.2	27.1
9926.0	Horn2	H			44.9	51.8	-44.0		52.7	79.2	26.5
12407.5	Horn2	V			44.8	56.6	-44.6		56.8	74.0	17.2
12407.5	Horn2	H			44.7	56.6	-44.6		56.7	74.0	17.3

Notes:
 1 B/C = biconical, B/L biconilog, L/P = log-periodic, H = horn, D/P = dipole
 2 Includes cable loss when amplifier is not used
 3 Includes cable loss
 (.) denotes failing emission level.

Peak limit for emissions in Restricted Bands is 20dB above 54dBµV/m Average Limit as per 15.35 (b).

Panasonic Spread Spectrum Cordless Telephone System, Model KX-TG210 Series
 Base Unit: FCC ID: ACJ96NKX-TG210 (Confirmation No.: EA89981)
 Handset Unit: FCC ID: ACJ96NKX-TG210B (Confirmation No.: EA90249)

EQUIPMENT: 2.4 GHz Spread Spectrum Cordless Telephone Base

Test Data - Radiated Emissions (PEAK)

Test Distance (meters) : 3		Range: A Tower		Receiver: HP8566B		RBW: 1 MHz VBW: 1 MHz		PEAK			
Standard: FCC Part 15, Subpart C			E.U.T. Model No.: KX-TG210 Base			Date: May 20, 1998		Tested By: Kevin Carr			
Freq. (MHz)	Ant.	Pol. (V/H)	Ant. HGT. (m)	Table (deg.)	RCVD Signal (dBµV/m)	Ant. Factor (dB) ¹	Amp. Gain (dB) ²	Attn Corr. (dB)	Field Strength (dBµV/m)	Limit	Margin (dB)
Channel 1											
4804.2	Horn2	V			47.7	40.8	-46.0	20	62.5	54	(8.5)
4804.2	Horn2	H			54.8	40.8	-46.0	20	69.6	54	(15.6)
7206	Horn2	V			45.4	46.2	-45.8	20	65.8	79.2	13.4
7206	Horn2	H			45.7	46.2	-45.8	20	66.1	79.2	13.1
9608.8	Horn2	V			44.7	51.4	-43.9		52.2	79.2	27.0
9608.8	Horn2	H			44.5	51.4	-43.9		52.0	79.2	27.2
12010.0	Horn2	V			44.6	55.0	-44.0		55.6	54.0	(1.6)
12010.0	Horn2	H			44.1	55.0	-44.0		55.1	54.0	(1.1)
Channel 16											
4881.0	Horn2	V			46.9	40.1	-46.0	20	62.0	54	(8.0)
4881.0	Horn2	H			50.7	41.1	-46.0	20	65.8	54	(11.8)
7321.5	Horn2	V			46.9	46.4	-45.7	20	67.6	54	(13.6)
7321.5	Horn2	H			45.8	46.4	-45.7	20	66.3	54	(12.3)
9762.0	Horn2	V			44.6	51.6	-44.4		51.3	79.2	27.9
9762.0	Horn2	H			44.6	51.6	-44.4		51.8	79.2	27.4
12202.5	Horn2	V			45.1	55.8	-44.3		56.6	54.0	(2.6)
12202.5	Horn2	H			45.0	55.8	-44.3		56.5	54.0	(2.5)
Channel 32											
4963.2	Horn2	V			46.4	41.4	-46.0	20	61.8	54	(7.8)
4963.2	Horn2	H			47.0	41.4	-46.0	20	62.4	54	(8.4)
7444.5	Horn2	V			45.2	46.6	-45.6	20	66.2	54	(12.2)
7444.5	Horn2	H			44.6	46.6	-45.6	20	65.6	54	(11.6)
9926.0	Horn2	V			44.3	51.8	-44.0		52.1	79.2	27.1
9926.0	Horn2	H			44.9	51.8	-44.0		52.7	79.2	26.5
12407.5	Horn2	V			44.8	56.6	-44.6		56.8	54.0	(2.8)
12407.5	Horn2	H			44.7	56.6	-44.6		56.7	54.0	(2.7)

Notes:
¹ B/C = biconical, B/L biconilog, L/P = log-periodic, H = horn, D/P = dipole
² Includes cable loss when amplifier is not used
³ Includes cable loss
 () denotes failing emission level.

KTL - Certelecom Laboratories Inc.

FCC PART 15, SUBPART C
 DIRECT SEQUENCE TRANSMITTERS
 PROJECT NO.: 8R00161.1

EQUIPMENT: 2.4 GHz Spread Spectrum Cordless Telephone Base

Test Data - Radiated Emissions (PEAK) Measured @ 1m

Test Distance (meters): 1		Range: A Tower		Receiver: HP8566B		RBW: 1 MHz VBW: 1 MHz		PEAK			
Standard: FCC Part 15, Subpart C			E.U.T. Model No.: KX-TG210 Base			Date: May 20, 1998		Tested By: Kevin Carr			
Freq. (MHz)	Ant.	Pol. (V/H)	Ant. HGT. (m)	Table (deg.)	RCVD Signal (dBµV/m)	Ant. Factor (dB) ¹	Amp. Gain (dB) ²	Dist. Corr. (dB)	Field Strength (dBµV/m)	Limit	Margin (dB)
Channel 1											
14413.2	Hrn2	V			34.6	44.1		-9.5	69.2	79.2	10.0
14413.2	Hrn2	H			35.0	44.1		-9.5	69.6	79.2	9.6
16815.4	Hrn2	V			34.1	41.0		-9.5	65.6	79.2	13.6
16815.4	Hrn2	H			34.2	41.0		-9.5	65.7	79.2	13.5
19217.6	SH50/60-1	V			37.6	40.2		-9.5	68.3	74.0	5.7
19217.6	SH50/60-1	H			37.4	40.2		-9.5	61.8	74.0	12.2
21619.8	SH50/60-1	V			39.1	40.6		-9.5	70.2	79.2	9.0
21619.8	SH50/60-1	H			41.0	40.6		-9.5	72.1	79.2	7.1
24022	SH50/60-1	V			41.5	40.7		-9.5	72.7	79.2	6.5
24022	SH50/60-1	H			41.5	40.7		-9.5	72.7	79.2	6.5
Channel 16											
14643	Hrn2	V			34.5	41.1		-9.5	66.1	79.2	13.1
14643	Hrn2	H			34.6	41.1		-9.5	66.2	79.2	13.0
17083.5	Hrn2	V			33.4	41.9		-9.5	65.8	79.2	13.4
17083.5	Hrn2	H			32.9	41.9		-9.5	65.3	79.2	13.9
195224	SH50/60-1	V			34.6	40.5		-9.5	65.6	74.0	8.4
195224	SH50/60-1	H			34.6	40.5		-9.5	65.6	74.0	8.4
21964.5	SH50/60-1	V			41.2	40.6		-9.5	72.3	79.2	6.9
21964.5	SH50/60-1	H			41.1	40.6		-9.5	72.2	79.2	7.0
24405	SH50/60-1	V			41.5	40.6		-9.5	72.6	79.2	6.6
24405	SH50/60-1	H			41.5	40.6		-9.5	72.6	79.2	6.6
Channel 32											
14889	Hrn2	V			32.8	39.0		-9.5	62.3	79.2	16.9
14889	Hrn2	H			33.0	39.0		-9.5	62.5	79.2	16.7
17370.5	Hrn2	V			33.3	44.1		-9.5	67.9	79.2	11.3
17370.5	Hrn2	H			33.1	44.1		-9.5	67.7	79.2	11.5
19852	SH50/60-1	V			37.3	40.5		-9.5	68.3	74.0	5.7
19852	SH50/60-1	H			37.7	40.5		-9.5	68.7	74.0	5.3
22333.5	SH50/60-1	V			40.7	40.6		-9.5	71.3	74.0	2.7
22333.5	SH50/60-1	H			40.3	40.6		-9.5	71.4	74.0	2.6
24815	SH50/60-1	V			41.5	40.7		-9.5	72.7	79.2	6.5
24815	SH50/60-1	H			41.5	40.7		-9.5	72.7	79.2	6.5

Notes:
¹ B/C = biconical, B/L = biconilog, L/P = log-periodic, H = horn, D/P = dipole
² Includes cable loss when amplifier is not used
³ Includes cable loss
 () denotes failing emission level.
 The above readings are noise floor.
 Peak limit for emissions in Restricted Bands is 20dB above 54dBµV/m Average Limit as per 15.35 (b).

Panasonic Spread Spectrum Cordless Telephone System, Model KX-TG210 Series
 Base Unit: FCC ID: ACJ96NKX-TG210 (Confirmation No.: EA89981)
 Handset Unit: FCC ID: ACJ96NKX-TG210B (Confirmation No.: EA90249)

Page 27 of 40

EQUIPMENT: 2.4 GHz Spread Spectrum Cordless Telephone Base

Test Data - Radiated Emissions (PEAK) Measured @ 1m

Test Distance (meters) : 1		Range: A Tower		Receiver: HP8566B		RBW: 1 MHz VBW: 1 MHz		PEAK			
Standard: FCC Part 15, Subpart C			E.U.T. Model No.: KX-TG210 Base			Date: May 20, 1998		Tested By: Kevin Carr			
Freq. (MHz)	Ant.	Pol. (V/H)	Ant. HGT. (m)	Table (deg.)	RCVD Signal (dBuV/m)	Ant. Factor (dB) ¹	Amp. Gain (dB) ²	Dist. Corr. (dB)	Field Strength (dBuV/m)	Limit	Margin (dB)
Channel 1											
14413.2	Hm2	V			34.6	44.1		-9.5	69.2	79.2	10.0
14413.2	Hm2	H			35.0	44.1		-9.5	69.6	79.2	9.6
16815.4	Hm2	V			34.1	41.0		-9.5	65.6	79.2	13.6
16815.4	Hm2	H			34.2	41.0		-9.5	65.7	79.2	13.5
19217.6	SH50/60-1	V			37.6	40.2		-9.5	68.3	54.0	(14.3)
19217.6	SH50/60-1	H			37.4	40.2		-9.5	61.8	54.0	(14.1)
21619.8	SH50/60-1	V			39.1	40.6		-9.5	70.2	79.2	9.0
21619.8	SH50/60-1	H			41.0	40.6		-9.5	72.1	79.2	7.1
24022	SH50/60-1	V			41.5	40.7		-9.5	72.7	79.2	6.5
24022	SH50/60-1	H			41.5	40.7		-9.5	72.7	79.2	6.5
Channel 16											
14643	Hm2	V			34.5	41.1		-9.5	66.1	79.2	13.1
14643	Hm2	H			34.6	41.1		-9.5	66.2	79.2	13.0
17083.5	Hm2	V			34.1	41.9		-9.5	65.8	79.2	13.4
17083.5	Hm2	H			32.9	41.9		-9.5	65.3	79.2	13.9
195224	SH50/60-1	V			34.6	40.5		-9.5	65.6	54.0	(11.6)
195224	SH50/60-1	H			34.6	40.5		-9.5	65.6	54.0	(11.6)
21964.5	SH50/60-1	V			41.2	40.6		-9.5	72.3	79.2	6.9
21964.5	SH50/60-1	H			41.1	40.6		-9.5	72.2	79.2	7.0
24405	SH50/60-1	V			41.5	40.6		-9.5	72.6	79.2	6.6
24405	SH50/60-1	H			41.5	40.6		-9.5	72.6	79.2	6.6
Channel 32											
14889	Hm2	V			32.8	39.0		-9.5	62.3	79.2	16.9
14889	Hm2	H			33.0	39.0		-9.5	62.5	79.2	16.7
17370.5	Hm2	V			33.3	44.1		-9.5	67.9	79.2	11.3
17370.5	Hm2	H			33.1	44.1		-9.5	67.7	79.2	11.5
19852	SH50/60-1	V			37.3	40.5		-9.5	68.3	54.0	(14.3)
19852	SH50/60-1	H			37.7	40.5		-9.5	68.7	54.0	(14.7)
22333.5	SH50/60-1	V			40.7	40.6		-9.5	71.3	54.0	(17.3)
22333.5	SH50/60-1	H			40.3	40.6		-9.5	71.4	54.0	(17.4)
24815	SH50/60-1	V			41.5	40.7		-9.5	72.7	79.2	6.5
24815	SH50/60-1	H			41.5	40.7		-9.5	72.7	79.2	6.5

Notes:
¹ B/C = biconical, B/L biconilog, L/P = log-periodic, H = horn. D/P = dipole
² Includes cable loss when amplifier is not used
³ Includes cable loss
 () denotes failing emission level.

The above readings are noise floor

EQUIPMENT: 2.4 GHz Spread Spectrum Cordless Telephone Base

Test Data - Radiated Emissions (AVERAGE)

Test Distance (meters) : 3		Range: A Tower		Receiver: HP8566B		RBW: 1 MHz VBW: 10 Hz		PEAK			
Standard: FCC Part 15, Subpart C			E.U.T. Model No.: KX-TG210 Base			Date: May 20, 1998		Tested By: Kevin Carr			
Freq. (MHz)	Ant.	Pol. (V/H)	Ant. HGT. (m)	Table (deg.)	RCVD Signal (dBµV/m)	Ant. Factor (dB) ²	Amp. Gain (dB) ²	Attn. Corr. (dB)	Field Strength (dBµV/m)	Limit	Margin (dB)
Channel 1											
4804.5	Horn2	V			30.0	40.8	-46.0	20	44.8	54	9.2
4804.5	Horn2	H			33.6	40.8	-46.0	20	48.4	54	5.6
7206	Horn2	V			28.3	46.2	-45.8	20	48.7	79.2	30.5
7206	Horn2	H			28.5	46.2	-45.8	20	48.9	79.2	30.3
9608.8	Horn2	V			33.3	51.4	-43.9		40.8	79.2	38.4
9608.8	Horn2	H			33.4	51.4	-43.9		40.9	79.2	38.3
12010	Horn2	V			33.1	55.0	-44.0		44.1	54	9.9
12010	Horn2	H			33.3	55.0	-44.0		44.3	54	9.7
Channel 16											
4881.0	Horn2	V			36.6	41.1	-46.0	20	51.7	54	2.3
4881.0	Horn2	H			34.1	41.1	-46.0	20	49.2	54	4.8
7321.5	Horn2	V			30.0	46.4	-45.7	20	50.7	54	3.3
7321.5	Horn2	H			30.5	46.4	-45.7	20	51.2	54	2.8
9762	Horn2	V			25.4	51.6	-44.4		32.6	79.2	46.6
9762	Horn2	H			25.5	51.6	-44.4		32.7	79.2	46.5
12202.5	Horn2	V			24.0	55.8	-44.3		35.5	54	18.5
12202.5	Horn2	H			23.9	55.8	-44.3		35.4	54	18.6
Channel 32											
4963.2	Horn2	V			35.2	41.4	-46.0	20	50.6	54	3.4
4963.2	Horn2	H			33.8	41.4	-46.0	20	49.2	54	4.8
7444.5	Horn2	V			30.8	46.6	-45.6	20	51.8	54	2.2
7444.5	Horn2	H			30.8	46.6	-45.6	20	51.8	54	2.2
9926.0	Horn2	V			25.6	51.8	-44.0		33.4	79.2	45.8
9926.0	Horn2	H			25.5	51.8	-44.0		33.3	79.2	45.9
12407.5	Horn2	V			24.1	56.6	-44.6		36.1	54	17.9
12407.5	Horn2	H			24.0	56.6	-44.6		36.0	54	18.0
Notes:											
¹ B/C = biconical, B/L biconilog, L/P = log-periodic, H = horn, D/P = dipole											
² Includes cable loss when amplifier is not used											
³ Includes cable loss											
() denotes failing emission level.											

KTL - Certelecom Laboratories Inc.

**FCC PART 15, SUBPART C
DIRECT SEQUENCE TRANSMITTERS
PROJECT NO.: BR00161.1**

EQUIPMENT: 2.4 GHz Spread Spectrum Cordless Telephone Base

Test Data - Radiated Emissions (AVERAGE), Measured at 1 m

Test Distance (meters): 1		Range: A Tower		Receiver: HP8566B		RBW: 1 MHz VBW: 10 Hz		PEAK			
Standard: FCC Part 15, Subpart C				E.U.T. Model No.: KX-TG210 Base		Date: May 20, 1998		Tested By: Kevin Carr			
Freq. (MHz)	Ant.	Pol. (V/H)	Ant. HGT. (m)	Tilt (deg)	RCVD Signal (dBµV/m)	Ant. Factor (dB) ²	Amp. Gain (dB) ³	Dist. Corr. (dB)	Field Strength (dBµV/m)	Limit	Margin (dB)
Channel 1											
14413.2	Hm2	V			28.0	44.1		-9.5	62.6	79.2	16.6
14413.2	Hm2	H			28.0	44.1		-9.5	62.6	79.2	16.6
16815.4	Hm2	V			28.1	41.0		-9.5	59.6	79.2	19.6
16815.4	Hm2	H			28.0	41.0		-9.5	59.5	79.2	19.7
19217.6	SH50/60-1	V			16.8	40.2		-9.5	47.5	54.0	6.5
19217.6	SH50/60-1	H			16.6	40.2		-9.5	47.3	54.0	6.7
21619.8	SH50/60-1	V			29.0	40.6		-9.5	60.1	79.2	19.1
21619.8	SH50/60-1	H			29.0	40.6		-9.5	60.1	79.2	19.1
24022	SH50/60-1	V			27.1	40.7		-9.5	58.3	79.2	20.9
24022	SH50/60-1	H			27.1	40.7		-9.5	58.3	79.2	20.9
Channel 16											
14643	Hm2	V			28.3	41.1		-9.5	59.9	79.2	19.3
14643	Hm2	H			28.5	41.1		-9.5	60.1	79.2	19.1
17083.5	Hm2	V			27.9	41.9		-9.5	60.3	79.2	18.9
17083.5	Hm2	H			28.0	41.9		-9.5	60.4	79.2	18.8
19524	SH50/60-1	V			17.1	40.5		-9.5	48.1	54.0	5.9
19524	SH50/60-1	H			17.1	40.5		-9.5	48.1	54.0	5.9
21964.5	SH50/60-1	V			24.6	40.6		-9.5	55.7	79.2	23.5
21964.5	SH50/60-1	H			24.7	40.6		-9.5	55.8	79.2	23.4
24405	SH50/60-1	V			27.1	40.6		-9.5	58.2	79.2	21.0
24405	SH50/60-1	H			27.1	40.6		-9.5	58.2	79.2	21.0
Channel 32											
14889	Hm2	V			27.9	39.0		-9.5	57.4	79.2	21.8
14889	Hm2	H			27.9	39.0		-9.5	57.4	79.2	21.8
17370.5	Hm2	V			28.2	44.1		-9.5	62.8	79.2	16.4
17370.5	Hm2	H			28.2	44.1		-9.5	62.8	79.2	16.4
19852	SH50/60-1	V			17.1	40.5		-9.5	48.1	54.0	5.9
19852	SH50/60-1	H			17.1	40.5		-9.5	48.1	54.0	5.9
22333.5	SH50/60-1	V			19.9	40.6		-9.5	51.0	54.0	3.0
22333.5	SH50/60-1	H			19.8	40.6		-9.5	50.9	54.0	3.1
24815	SH50/60-1	V			27.0	40.7		-9.5	58.2	79.2	21.0
24815	SH50/60-1	H			27.1	40.7		-9.5	58.3	79.2	20.9

Notes:
¹ B/C = biconical, B/L, biconilog, L/P = log-periodic, H = horn, D/P = dipole
² Includes cable loss when amplifier is not used
³ Includes cable loss
 () denotes failing emission level.
 The above readings are noise floor.

Panasonic Spread Spectrum Cordless Telephone System, Model KX-TG210 Series
Base Unit: FCC ID: ACJ96NKX-TG210 (Confirmation No.: EA89981)
Handset Unit: FCC ID: ACJ96NKX-TG210B (Confirmation No.: EA90249)

EQUIPMENT: 2.4 GHz Spread Spectrum Cordless Telephone Base

Test Data - Radiated Emissions (AVERAGE), Measured at 1 m

Test Distance (meters) : 1		Range: A Tower		Receiver: HP8566B		RBW: 1 MHz VBW: 10 Hz		PEAK			
Standard: FCC Part 15, Subpart C			E.U.T. Model No.: KX-TG210 Base			Date: May 20, 1998		Tested By: Kevin Carr			
Freq. (MHz)	Ant. ¹	Pol. (V/H)	Ant. HGT. (m)	Table (deg.)	RCVD Signal (dBµV/m)	Ant. Factor (dB) ²	Amp. Gain (dB) ³	Dist. Corr. (dB)	Field Strength (dBµV/m)	Limit	Margin (dB)
Channel 1											
14413.2	Hrn2	V			28.0	44.1		-9.5	69.1	79.2	10.1
14413.2	Hrn2	H			28.0	44.1		-9.5	69.1	79.2	10.1
16815.4	Hrn2	V			28.1	41.0		-9.5	69.1	79.2	10.1
16815.4	Hrn2	H			28.0	41.0		-9.5	69.0	79.2	10.2
19217.6	SH50/60-1	V			16.8	40.2		-9.5	57.0	54.0	6.5
19217.6	SH50/60-1	H			16.6	40.2		-9.5	56.8	54.0	6.7
21619.8	SH50/60-1	V			29.0	40.6		-9.5	69.6	79.2	9.6
21619.8	SH50/60-1	H			29.0	40.6		-9.5	69.6	79.2	9.6
24022	SH50/60-1	V			27.1	40.7		-9.5	67.8	79.2	11.4
24022	SH50/60-1	H			27.1	40.7		-9.5	67.8	79.2	11.4
Channel 16											
14643	Hrn2	V			28.3	41.1		-9.5	69.4	79.2	9.8
14643	Hrn2	H			28.5	41.1		-9.5	69.6	79.2	9.6
17083.5	Hrn2	V			27.9	41.9		-9.5	69.8	79.2	9.4
17083.5	Hrn2	H			28.0	41.9		-9.5	69.9	79.2	9.3
19524	SH50/60-1	V			17.1	40.5		-9.5	57.6	54.0	5.9
19524	SH50/60-1	H			17.1	40.5		-9.5	57.6	54.0	5.9
21964.5	SH50/60-1	V			24.6	40.6		-9.5	65.2	79.2	14.0
21964.5	SH50/60-1	H			24.7	40.6		-9.5	65.3	79.2	13.9
24405	SH50/60-1	V			27.1	40.6		-9.5	67.7	79.2	11.5
24405	SH50/60-1	H			27.1	40.6		-9.5	67.7	79.2	11.5
Channel 32											
14889	Hrn2	V			27.9	39.0		-9.5	56.9	79.2	22.3
14889	Hrn2	H			27.9	39.0		-9.5	56.9	79.2	22.3
17370.5	Hrn2	V			28.2	44.1		-9.5	72.3	79.2	6.9
17370.5	Hrn2	H			28.2	44.1		-9.5	72.3	79.2	6.9
19852	SH50/60-1	V			17.1	40.5		-9.5	57.6	54.0	5.9
19852	SH50/60-1	H			17.1	40.5		-9.5	57.6	54.0	5.9
22333.5	SH50/60-1	V			19.9	40.6		-9.5	60.5	54.0	3.0
22333.5	SH50/60-1	H			19.8	40.6		-9.5	60.4	54.0	3.1
24815	SH50/60-1	V			27.0	40.7		-9.5	67.7	79.2	11.5
24815	SH50/60-1	H			27.1	40.7		-9.5	67.8	79.2	11.4

Notes:
¹ B/C = biconical, B/L biconilog, L/P = log-periodic, H = horn, D/P = dipole
² Includes cable loss when amplifier is not used
³ Includes cable loss
 () denotes failing emission level.
 The above readings are noise floor

ACCEPTED
 C. Carr

ACCEPTED
 SHEET

EQUIPMENT: 2.4 GHz Spread Spectrum Cordless Telephone Base

NAME OF TEST: Transmitter Power Density	PARA. NO.: 15.247(d)
TESTED BY: Kevin Carr	DATE: April 21, 1998

TEST RESULTS: Complies.

MEASUREMENT DATA: See attached graphs.

WORST CASE: $\text{Log}^{-1}\left(\frac{50.5 + 28.6}{20}\right) \text{dB}\mu\text{V} = 9015.7\mu\text{V}$

$$\text{EIRPs} \left(\frac{9015.7 \times 10^{-6}}{30}\right)^2 \times 9 = 2.43 \times 10^{-5} \text{ W}$$

$$10 \text{ Log } 2.43 \times 10^{-5} \text{ W} = -16.1 \text{ dBm}$$

*ATTEN 0dB
RL 45.2dB V 2dB/

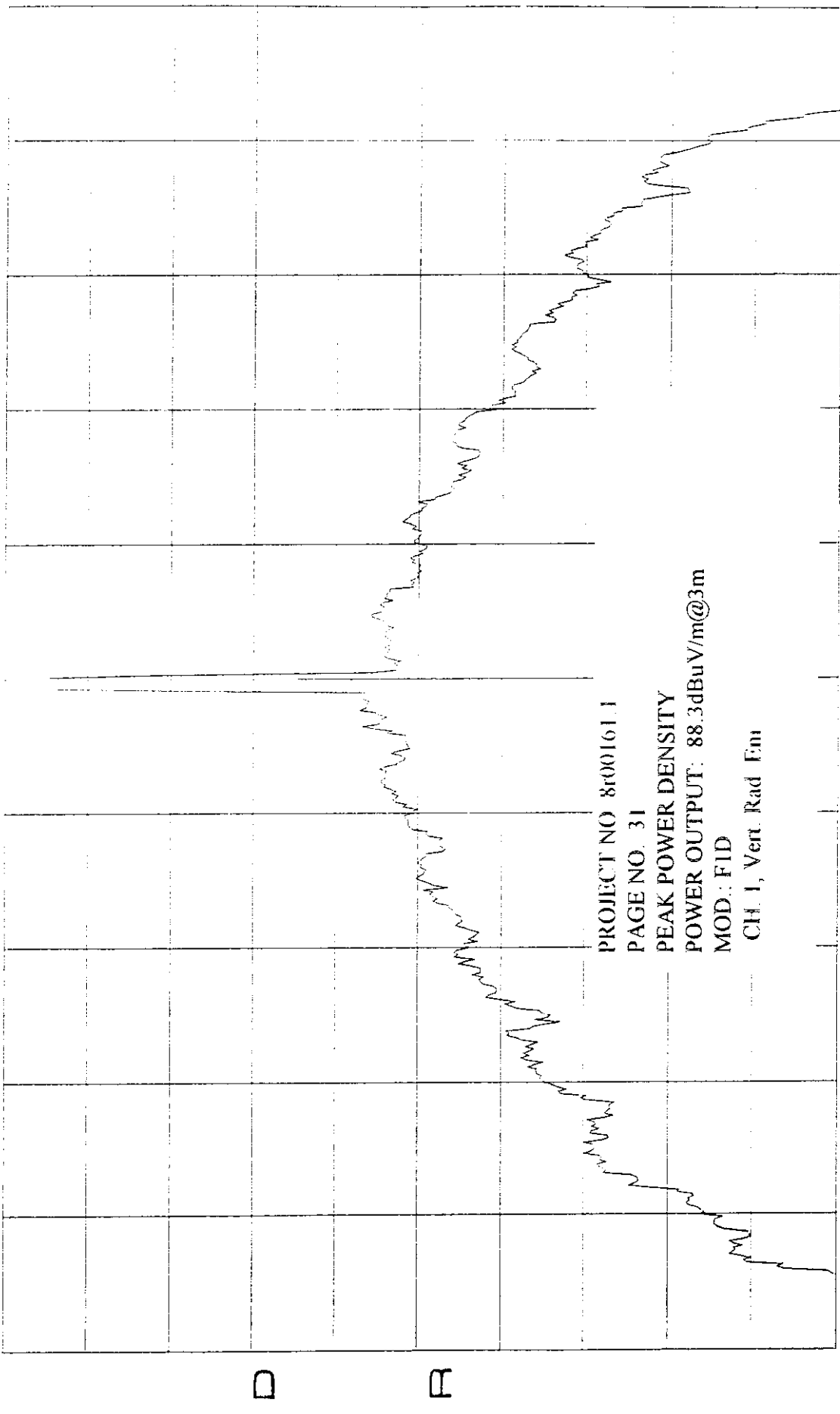

PROJECT NO 8r001611
PAGE NO. 31
PEAK POWER DENSITY
POWER OUTPUT: 88.3dBuV/m@3m
MOD: FID
CH 1, Vert. Rad Em

CENTER 2.402085GHZ
*RBW 3.0KHZ *VBW 1.0KHZ
SPAN 2.000MHZ *SWP 667sec

ATTEN 10dB , MKR - .30dB
RL 51.0dB V 2dB / 1.450MHZ

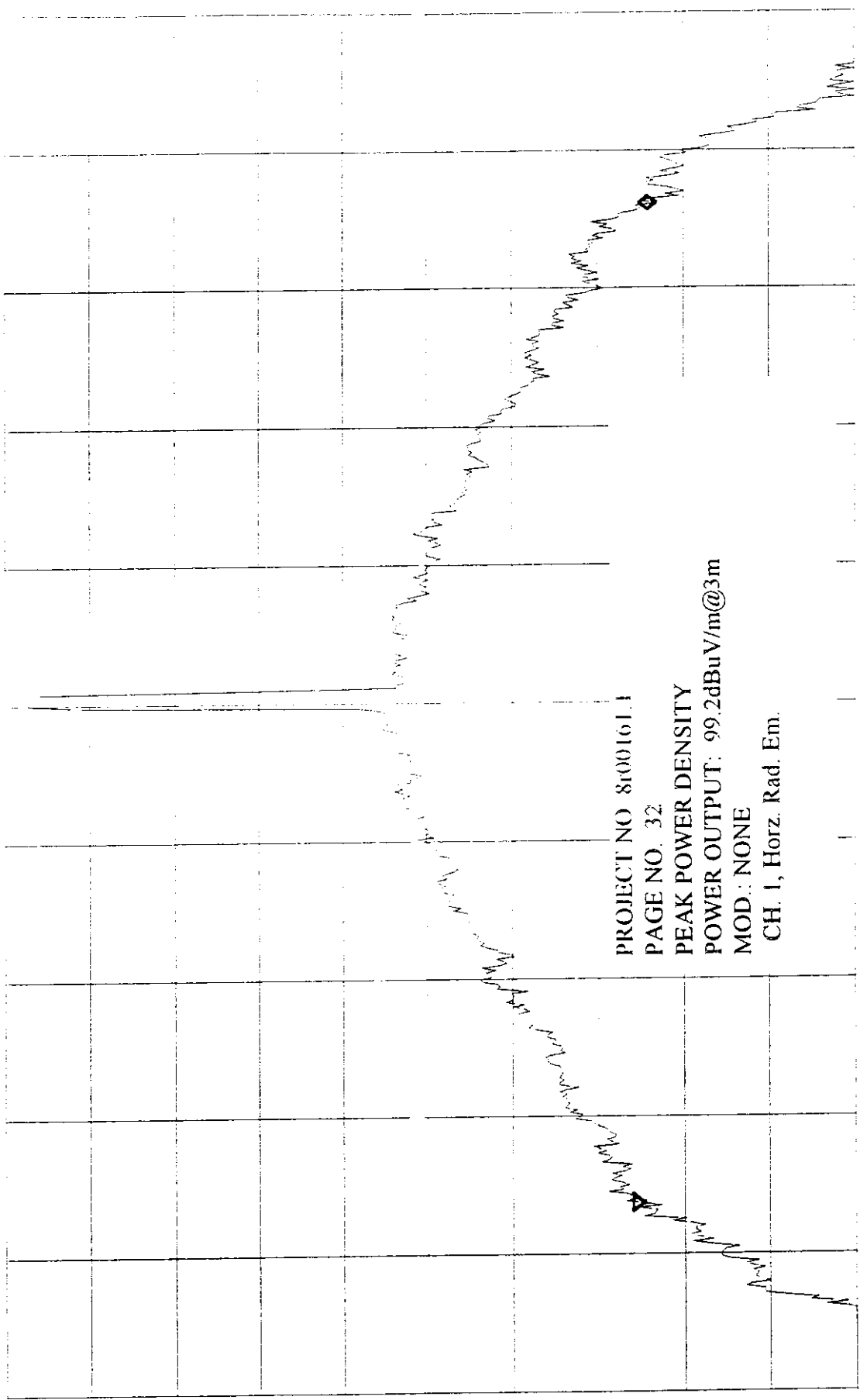

PROJECT NO 8r00161.1
PAGE NO. 32
PEAK POWER DENSITY
POWER OUTPUT: 99.2dBuV/m@3m
MOD.: NONE
CH. 1, Horz. Rad. Em.

CENTER 2.402073GHZ SPAN 2.000MHZ
*RBW 3.0KHZ *VBW 10KHZ *SWP 667sec

D

*ATTEN 0dB
RL 40.0dB V 2dB/

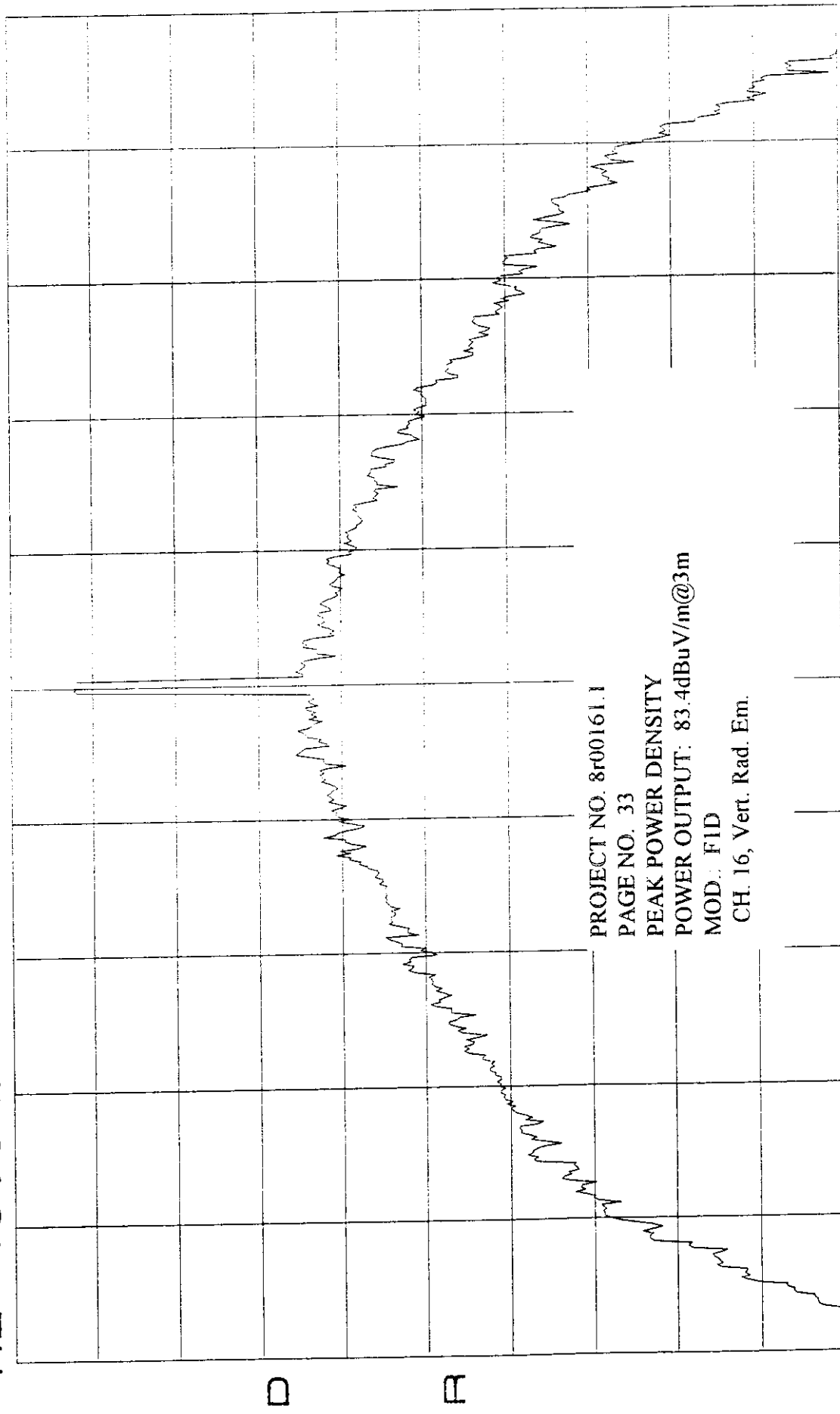

CENTER 2.440480GHZ
*RBW 3.0KHZ *VBW 10KHZ
SPAN 2.000MHZ
*SWP 667sec

*ATTEN 0dB , MKR -.07dB

RL 47.0dB V 2dB/ 1.457MHZ

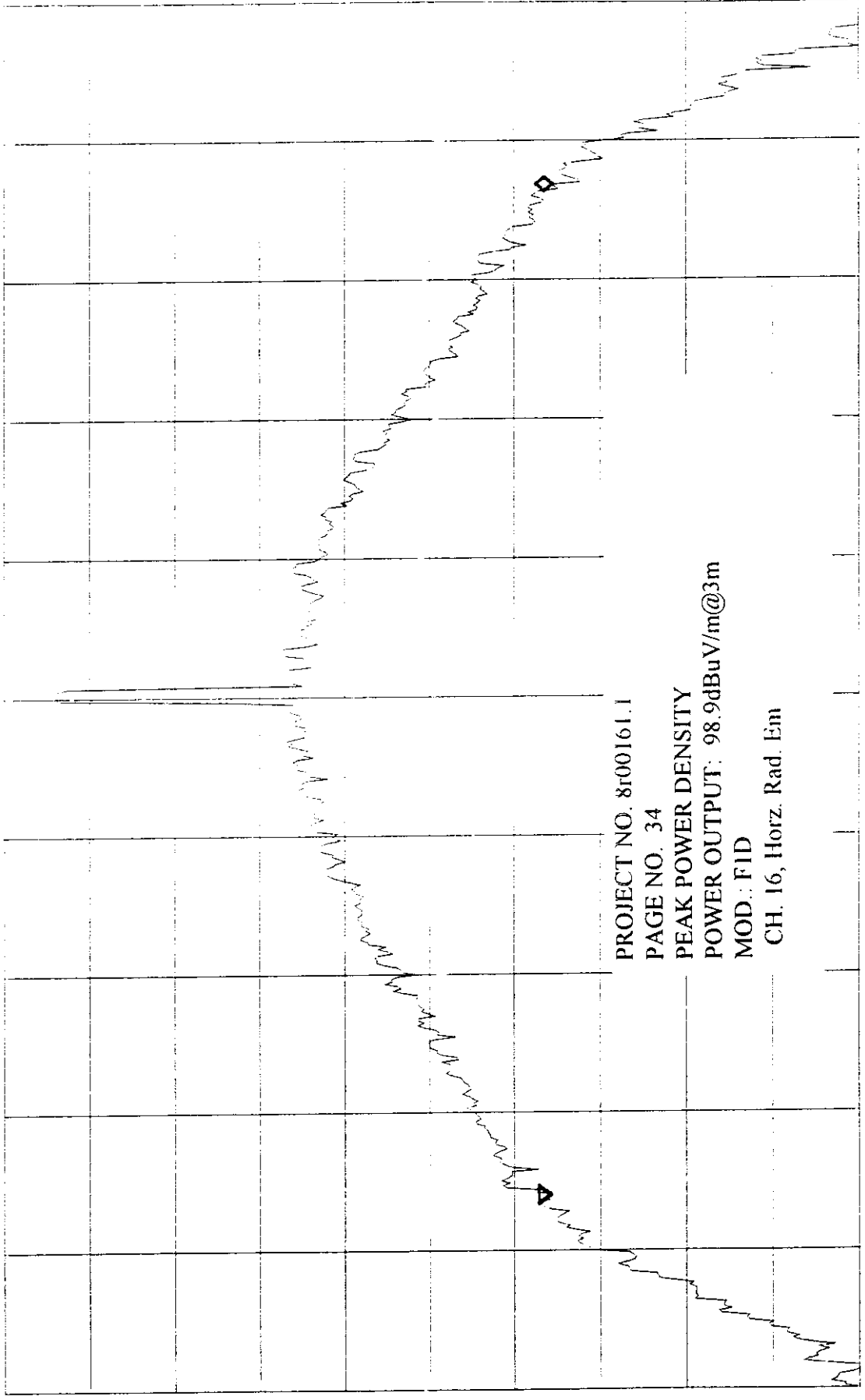

D

PROJECT NO. 8r00161.1
PAGE NO. 34
PEAK POWER DENSITY
POWER OUTPUT: 98.9dBuV/m@3m
MOD.: FID
CH. 16, Horiz. Rad. Em

CENTER 2.440477GHZ

SPAN 2.000MHZ

*RBW 3.0KHZ *VBW 10KHZ

*SWP 667sec

*ATTEN 0dB ,
RL 35.8dB V 2dB/

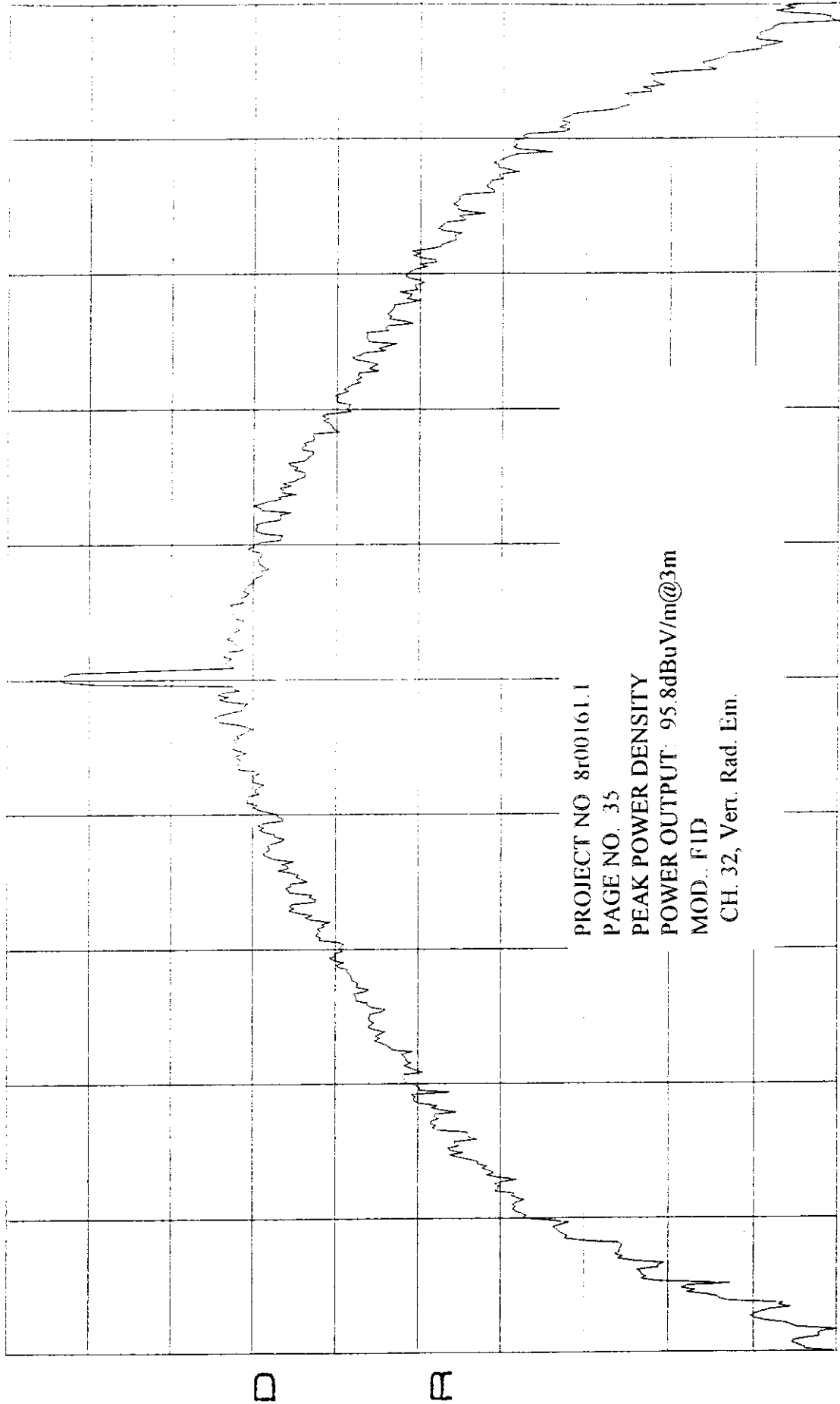

CENTER 2.481439GHZ SPAN 2.000MHZ
*RBW 3.0KHZ *VBW 10KHZ *SWP 667sec

*ATTEN 0dB MKR .44dB

RL 43.0dB V 1.510MHZ

2dB/

D

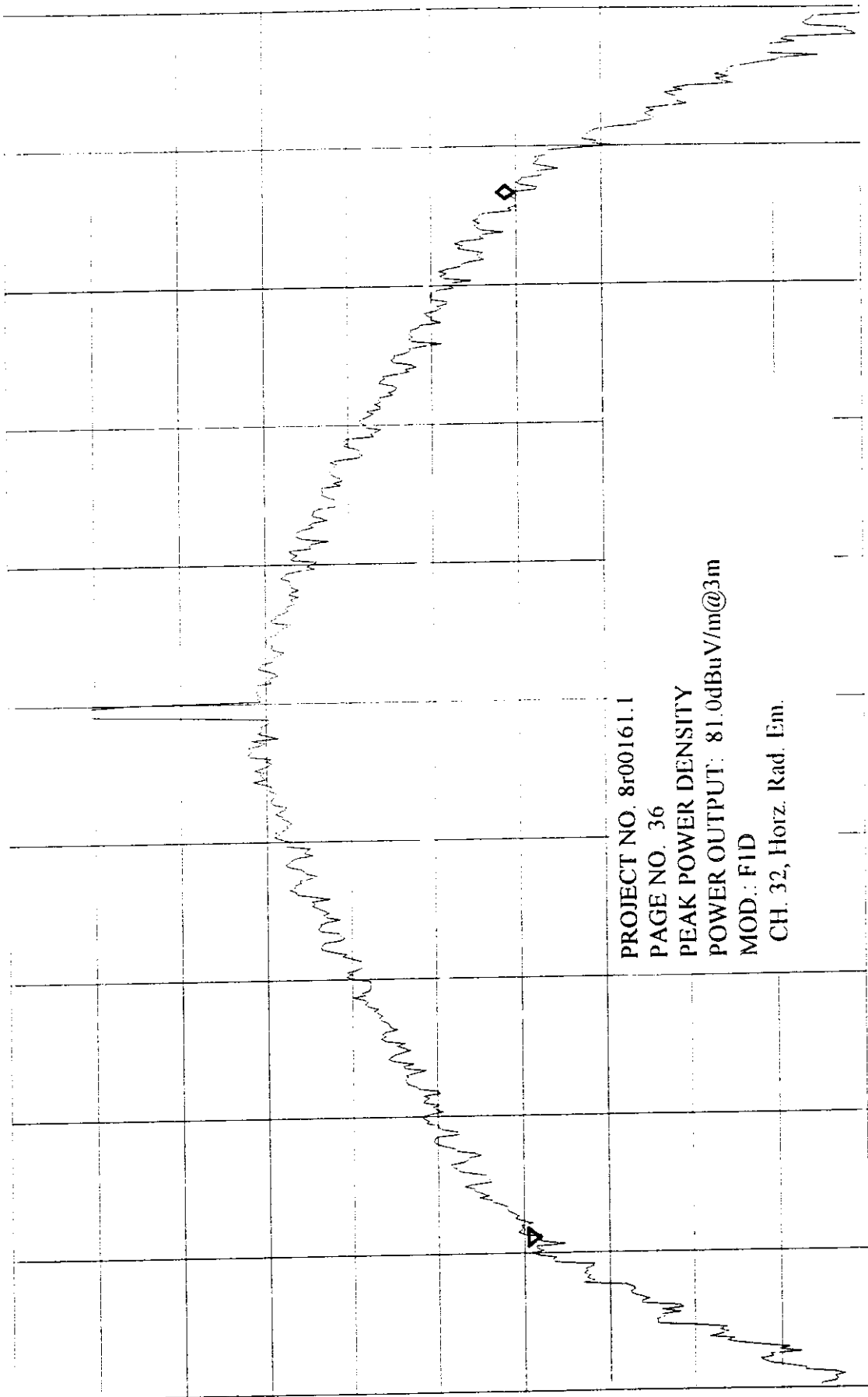

PROJECT NO. 8100161.1

PAGE NO. 36

PEAK POWER DENSITY

POWER OUTPUT: 81.0dBuV/m@3m

MOD.: FID

CH. 32, Horiz. Rad. Em.

CENTER 2.481450GHZ

SPAN 2.000MHZ

*RBW 3.0KHZ

*VBW 10KHZ

*SWP 667sec

EQUIPMENT: 2.4 GHz Spread Spectrum Cordless Telephone Base

NAME OF TEST: Processing Gain	PARA. NO.: 15.247(e)
-------------------------------	----------------------

TESTED BY: Panasonic Supplier Data	DATE: May 7, 1998
------------------------------------	-------------------

TEST CONDITIONS: Standard Temperature and Humidity: 20° C
 Standard Test Voltage: 120VAC

MINIMUM STANDARD: The processing gain shall be at least 10 dB.

TEST RESULTS: Complies. The processing gain of the system is 15.1 dB.

MEASUREMENT DATA: See attached data.

BER:

S/N_{min}:

J S ratio:

*B means Black (Color variation)

Test Results

3/6
pg 38

KX-TG210B Process Gain

Kyushu Matsushita Electric Co.,Ltd
Forth Division Engineering Department
H.Hamada

	Portable Unit	Base Unit
Δf (kHz)	D/U Ratio(dB)	D/U Ratio(dB)
1200	26.2	28.0
1150	22.2	27.0
1100	22.2	25.4
1050	22.5	23.6
1000	18.7	21.9
950	16.7	21.2
900	18.1	18.9
850	15.0	18.0
800	12.6	17.1
750	14.1	14.3
700	13.9	13.8
650	10.7	13.0
600	10.9	11.5
550	12.1	10.0
500	10.4	11.3
450	10.0	11.2
400		10.1
350		
300	9.8	
250		
200		
150	10.4	
100		
50		
0		
-50	9.2	12.3
-100	12.8	12.0
-150		
-200	9.0	10.6
-250	9.3	11.6
-300	10.0	
-350		10.5
-400	12.0	11.2
-450	11.0	12.9
-500	11.5	11.6
-550	10.9	11.6
-600	16.5	13.4
-650	14.0	14.0
-700	13.0	14.9
-750	16.8	16.5
-800	16.8	18.6
-850	20.0	21.5
-900	21.3	24.2
-950	21.5	25.7
-1000	25.5	25.7
-1050	24.4	26.0
-1100	26.6	26.6
-1150	31.3	26.9
-1200	28.0	27.4

D/U Ratio = (Desire Signal) / (Undesired Signal) Ratio

channel : 1ch

■ worst 20% points
These points are excluded.

OMj Jamming Margin

Mj(J/S ratio)	
Portable	9.2dB
Base	10.1dB

*Mj level is worst value after exclude worst 20% point

OProcess Gain

$G_p = (S/N)_o + M_j + L_{sys}$

$(S/N)_o = 3.0dB$

$L_{sys} = 2.0dB$

Mj: compare above table.

Gp (Process Gain)		
Portable	14.2dB	(=9.2+3+2)
Base	15.1dB	(=10.1+3+2)

OMeasurement Equipment

Signal Generator

HEWLETT PACKERD ESG-D3000A

Audio Analyzer

HEWLETT PACKERD 8903B

Four port junction Pad

Anritsu MA1812A

50 ohm terminator

HWELETT PACKERD 908A

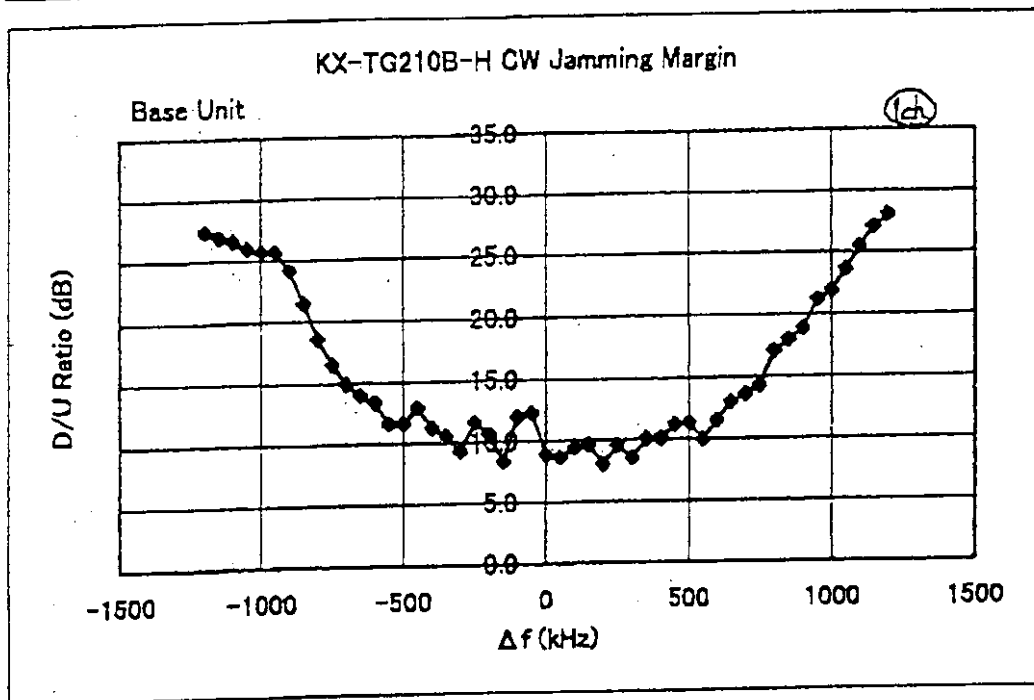
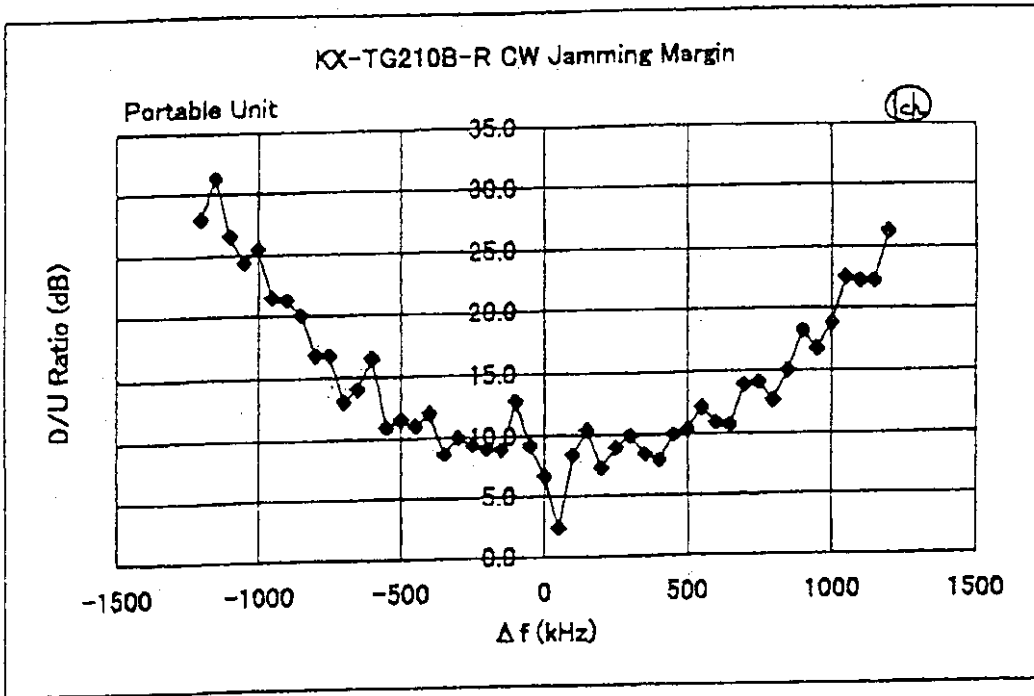

2/6
 P2 40

KX-TG210 Process gain

$$G_p = (C/N)_0 + M_j + L_{sys}$$

$G_p =$ KX-TG210 Process Gain

$(S/N)_0 =$ S/N ratio for keeping 12dB SINAD

The Base band signals of this model are analog.

$(S/N)_0$ is 3dB on this system.

$M_j =$ J/S ratio (CW Jamming margin method)

$L_{sys} =$ system loss (≤ 2.0 dB)

1. Method of measurement CW Jamming margin

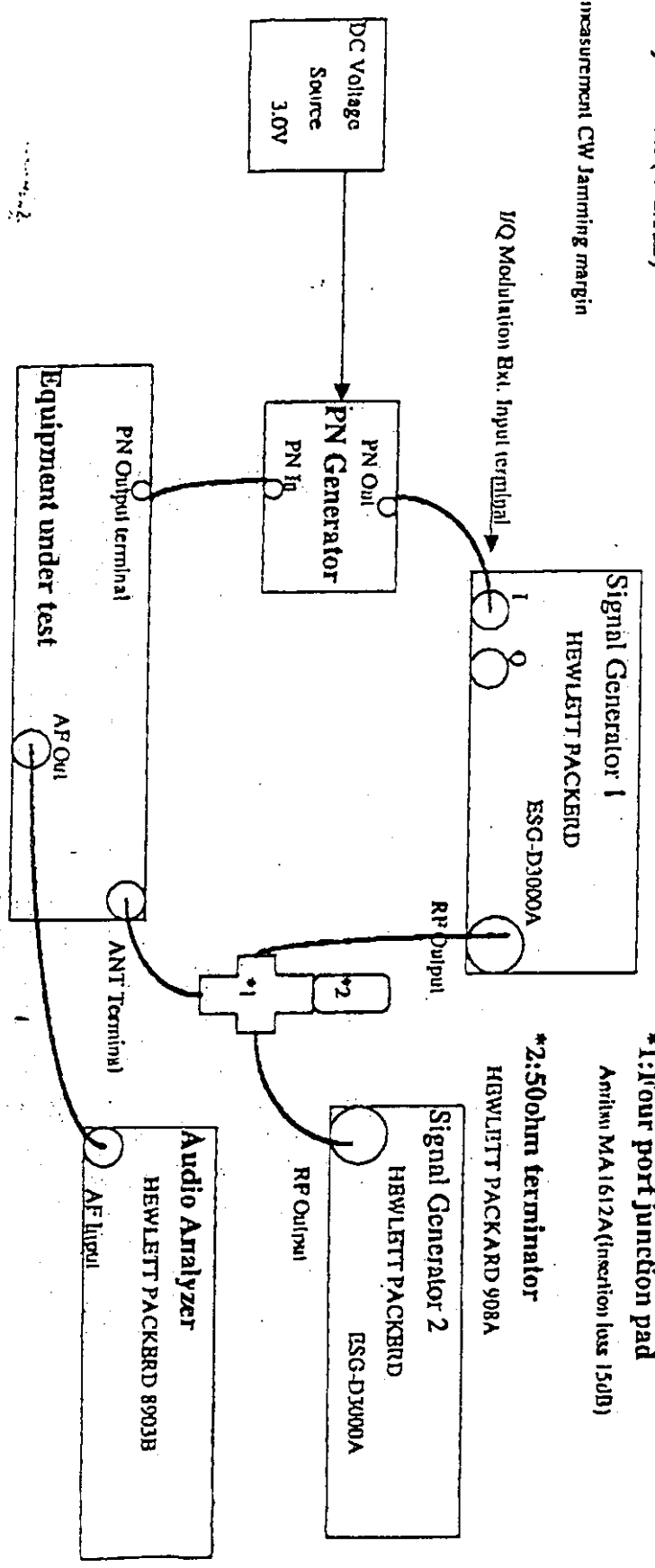

*1: Four port junction pad

Arifun MA1612A (insertion loss 15dB)

*2: 50ohm terminator

HEWLETT PACKARD 908A

KTL - Certelem Laboratories Inc.

FCC PART 15, SUBPART C
DIRECT SEQUENCE TRANSMITTERS
PROJECT NO.: SR00161.1
ANNEX A

EQUIPMENT: 2.4 GHz Spread Spectrum Cordless Telephone Base

ANNEX A

TEST METHODOLOGIES

EQUIPMENT: 2.4 GHz Spread Spectrum Cordless Telephone Base

NAME OF TEST: Powerline Conducted Emissions	15.207(a)
---	-----------

TEST CONDITIONS: Standard Temperature and Humidity
 Standard Test Voltage

MINIMUM STANDARD: The R.F. that is conducted back onto the AC power line on any frequency within the band 0.45 to 30 MHz shall not exceed 250 μ V (48 dB μ V) across 50 ohms.

EQUIPMENT: 2.4 GHz Spread Spectrum Cordless Telephone Base

NAME OF TEST: Occupied Bandwidth	PARA. NO.: 15.247(a)(2)
----------------------------------	-------------------------

TEST CONDITIONS: Standard Temperature and Humidity
Standard Test Voltage

MINIMUM STANDARD: The minimum bandwidth shall be at least 500 kHz.

METHOD OF MEASUREMENT:

The spectrum analyzer is set as follows:

RBW: 100 kHz
VBW: 100 kHz
Span: >RBW
LOG dB/div.: 2 dB
Sweep: Auto

Number of channels tested:

Tuning range	Number of channels tested	Channel location in band
1 MHz or less	1	middle
1 to 10 MHz	2	top and bottom
more than 10 MHz	3	top, middle, bottom

EQUIPMENT: 2.4 GHz Spread Spectrum Cordless Telephone Base

NAME OF TEST: Peak Power Output	PARA. NO.: 15.247(b)
---------------------------------	----------------------

TEST CONDITIONS: Standard Temperature and Humidity
 Standard Test Voltage

MINIMUM STANDARD: The maximum peak power output shall not exceed 1 watt.
 If transmitting antennas of directional gain greater than 6 dBi are used, the power shall be reduced by the amount in dB that the directional gain of the antenna exceeds 6 dBi.

DIRECT MEASUREMENT METHOD FOR DETACHABLE ANTENNAS:
 If the antenna is detachable, a peak power meter is used to measure the power output with the transmitter operating into a 50 ohm load.

CALCULATION OF EIRP FOR INTEGRAL ANTENNA:
 If the antenna is not detachable from the circuit then the Peak Power Output is derived from the peak radiated field strength of the fundamental emission by using the plane wave relation $GP/4\pi R^2 = E^2/120\pi$ and proceeding as follows:

$$P = \frac{E^2 R^2}{30G} = \frac{E^2 3^2}{30G}$$

where,

- P = the equivalent isotropic radiated power in watts
- E = the maximum measured field strength in V/m
- R = the measurement range (3 meters)
- G = the numeric gain of the transmit antenna in relation to an isotropic radiator

The RBW of the spectrum analyzer shall be set to a value greater than the measured 6 dB occupied bandwidth of the E.U.T.

Number of channels tested:

Tuning range	Number of channels tested	Channel location in band
1 MHz or less	1	middle
1 to 10 MHz	2	top and bottom
more than 10 MHz	3	top, middle, bottom

CH. 1 Hor2 88.3 dBμV @ 3m → 2402.05M
 CH32 Hor2 82.3 dBμV @ 3m → 2481.71M
 CH16 Hor2 83.2 dBμV @ 3m → 2440.82M

EQUIPMENT: 2.4 GHz Spread Spectrum Cordless Telephone Base

NAME OF TEST: Spurious Emissions at Antenna Terminals PARA. NO.: 15.247(c)

TEST CONDITIONS: Standard Temperature and Humidity
 Standard Test Voltage

MINIMUM STANDARD: In any 100kHz bandwidth outside the 902 - 928 MHz bands emissions shall be at least 20 dB below the fundamental emission or shall not exceed the following field strength limits. Emissions falling in the restricted bands of 15.205 shall not exceed the following field strength limits:

Frequency (MHz)	Field Strength (µV/m @ 3m)	Field Strength (dB @ 3m)
30 - 88	100	40.0
88 - 216	150	43.5
216 - 960	200	46.0
Above 960	500	54.0

THE SPECTRUM WAS SEARCHED TO THE 10th HARMONIC

METHOD OF MEASUREMENT:

30 MHz - 10th harmonic plot

RBW: 100 kHz
 VBW: 300 kHz
 Sweep: Auto
 Display line: -20 dBc

Lower Band Edge

RBW: At least 1% of span/div.
 VBW: >RBW
 Span: As necessary to display any spurious at band edge.
 Sweep: Auto
 Center Frequency: 2400 MHz
 Marker: Peak of fundamental emission
 Marker Δ: Peak of highest spurious level below 2400 MHz

Upper Band Edge

RBW: At least 1% of span/div.
 VBW: >RBW
 Span: As necessary to display any spurious at band edge.
 Sweep: Auto
 Center Frequency: 2483.5 MHz
 Marker: Peak of fundamental emission
 Marker Δ: Peak of highest spurious level above 2483.5 MHz

Number of channels tested:

Tuning range	Number of channels tested	Channel location in band
1 MHz or less	1	middle
1 to 10 MHz	2	top and bottom
more than 10 MHz	3	top, middle, bottom

*ATTEN 0dB MKR -52.67dBm

RL -10.0dBm 2.481450GHZ

10dB/

10dB/

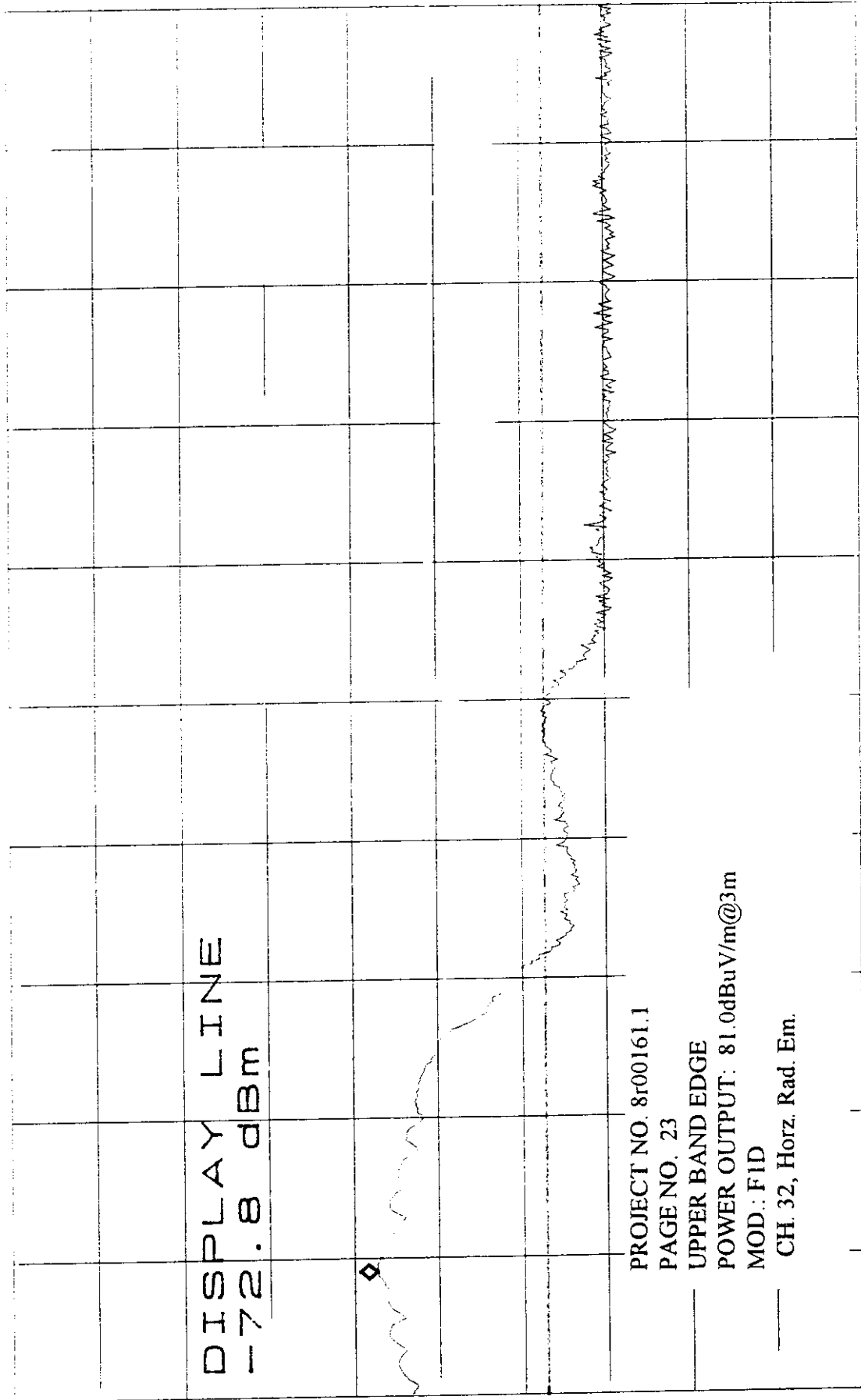

D

CENTER 2.483500GHZ

SPAN 5.000MHZ

*RBW 100KHZ

*VBW 300KHZ

SWP 50.0ms

EQUIPMENT: 2.4 GHz Spread Spectrum Cordless Telephone Base

NAME OF TEST: Spurious Emissions (Radiated)

PARA. NO.: 15.247(c)

TESTED BY: Kevin Carr

DATE: April 27, 1998

TEST RESULTS: Complies. The worst-case emission level is 51.8dB μ V/m @ 3m at 7444.5 MHz. This is 2.2 dB below the specification limit.

MEASUREMENT DATA: See attached table.

EQUIPMENT: 2.4 GHz Spread Spectrum Cordless Telephone Base

NAME OF TEST: Radiated Spurious Emissions PARA. NO.: 15.247(c)

TEST CONDITIONS: Standard Temperature and Humidity
 Standard Test Voltage

MINIMUM STANDARD: In any 100kHz bandwidth outside the 902 - 928 MHz bands emissions shall be at least 20 dB below the fundamental emission or shall not exceed the following field strength limits. **Emissions falling in the restricted bands of 15.205 shall not exceed the following field strength limits:**

Frequency (MHz)	Field Strength ($\mu\text{V/m @ 3m}$)	Field Strength (dB @ 3m)
30 - 88	100	40.0
88 - 216	150	43.5
216 - 960	200	46.0
Above 960	500	54.0

THE SPECTRUM WAS SEARCHED TO THE 10th HARMONIC

15.205 Restricted Bands

MHz	MHz	MHz	GHz
0.09-0.11	16.42-16.423	399.9-410	4.5-5.25
0.495-0.505	16.69475-16.69525	608-614	5.35-5.46
2.1735-2.1905	16.80425-16.80475	960-1240	7.25-7.75
4.125-4.128	25.5-25.67	1300-1427	8.025-8.5
4.17725-4.17775	37.5-38.25	1435-1626.5	9.0-9.2
4.20725-4.20775	73-74.6	1645.5-1646.5	9.3-9.5
6.125-6.218	74.8-75.2	1660-1710	10.6-12.7
6.26775-6.26825	108-121.94	1718.8-1722.2	13.25-13.4
6.31175-6.31225	123-138	2200-2300	14.47-14.5
8.291-8.294	149.9-150.05	2310-2390	15.35-16.2
8.362-8.366	156.52475-156.52525	2483.5-2500	17.7-21.4
8.37625-8.38675	156.7-156.9	2655-2900	22.01-23.12
8.41425-8.41475	162.0125-167.17	3260-3267	23.6-24.0
12.29-12.293	167.72-173.2	3332-3339	31.2-31.8
12.51975-12.52025	240-285	3345.8-3358	36.43-36.5
12.57675-12.57725	322-335.4	3600-4400	Above 38.6
13.36-13.41	1718		

Number of channels tested:

Tuning range	Number of channels tested	Channel location in band
1 MHz or less	1	middle
1 to 10 MHz	2	top and bottom
more than 10 MHz	3	top, middle, bottom

EQUIPMENT: 2.4 GHz Spread Spectrum Cordless Telephone Base

NAME OF TEST: Transmitter Power Density	PARA. NO.: 15.247(d)
---	----------------------

TEST CONDITIONS: Standard Temperature and Humidity
 Standard Test Voltage

MINIMUM STANDARD: The transmitted power density averaged over any 1 second interval shall not be greater than +8 dBm in any 3 kHz bandwidth.

METHOD OF MEASUREMENT:
 The spectrum analyzer is set as follows:

- RBW: 3 kHz
- VBW: >3 kHz
- Span: => measured 6 dB bandwidth
- Sweep: Span(kHz)/3 (i.e. for a span of 1.5 MHz the sweep rate is 1500/3 = 500 sec.
- LOG dB/div.: 2 dB

NOTE: For devices with spectrum line spacing =< 3 kHz, the RBW of the analyzer is reduced until the spectral lines are resolved. The measurement data is normalized to 3 kHz by summing the power of all the individual spectral lines within a 3 kHz band in linear power units.

Number of channels tested:

Tuning range	Number of channels tested	Channel location in band
1 MHz or less	1	middle
1 to 10 MHz	2	top and bottom
more than 10 MHz	3	top, middle, bottom

EQUIPMENT: 2.4 GHz Spread Spectrum Cordless Telephone Base

NAME OF TEST: Processing Gain

PARA. NO.: 15.247(e)

TEST CONDITIONS: Standard Temperature and Humidity
Standard Test Voltage

MINIMUM STANDARD: The processing gain shall be at least 10 dB.

METHOD OF MEASUREMENT:

The CW jamming margin method was used to determine the processing gain. A CW signal generator is stepped across the passband of the receiver in 50 kHz increments. At each point the signal generator level required to obtain the recommended bit error rate is recorded. The jammer to signal ratio (J/S) is then calculated. The worst 20% of the J/S points is discarded. The lowest remaining J/S ratio is used to calculate the processing gain.

CALCULATION OF PROCESSING GAIN:

The processing gain was determined by measuring the jamming margin of the E.U.T. and using the following formula:

$$\text{Jamming Margin} = G_p - (S/N)_{\text{out}} - L_{\text{sys}}$$

For a receiver using non-coherent detection the value $(S/N)_{\text{out}}$ is calculated using the formula:

$P_e = (1/2)\text{EXP}\{-E/2N_o\}$ where P_e is the probability of error (minimum Bit Error Rate required for proper operation).

E/N_o is $(S/N)_{\text{out}}$
for example, for a bit error rate of 10^{-4} a S/N ratio of 12.3 dB is required.

L_{sys} (system losses) is assumed to be 2 dB.

Therefore $G_p = M_j + (S/N)_{\text{out}} + L_{\text{sys}}$

Measurement performed at 915 MHz.

KTL - Certelecom Laboratories Inc.

FCC PART 15, SUBPART C
DIRECT SEQUENCE TRANSMITTERS
PROJECT NO.: 8R00161.1
ANNEX B

EQUIPMENT: 2.4 GHz Spread Spectrum Cordless Telephone Base

ANNEX B

BLOCK DIAGRAMS

EQUIPMENT: 2.4 GHz Spread Spectrum Cordless Telephone Base

TEST SITE FOR RADIATED EMISSIONS

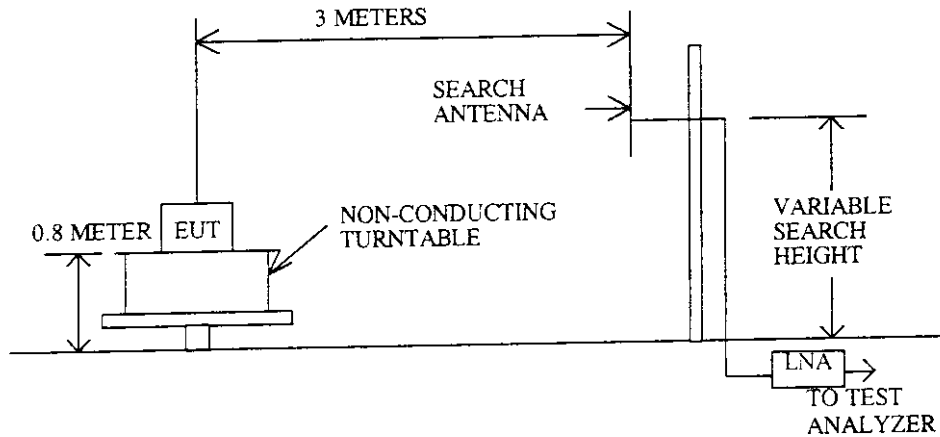

Below 1 GHz
Peak detector.
RBW = 100 kHz

Above 1 GHz for Peak emission levels
Peak detector
RBW = 1 MHz
VBW = >RBW

Above 1 GHz for Average emission levels
Peak detector
RBW = 1 MHz
VBW = 10 Hz

CONDUCTED EMISSIONS

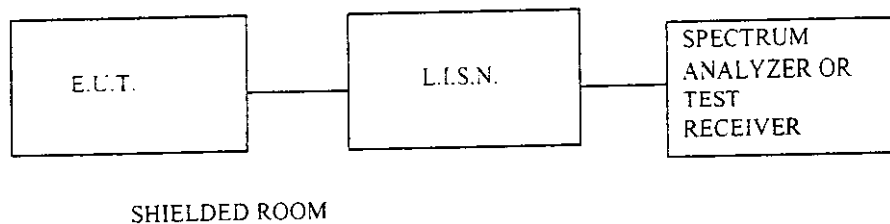

EQUIPMENT: 2.4 GHz Spread Spectrum Cordless Telephone Base

TRANSMITTER POWER DENSITY & PEAK POWER AT ANTENNA TERMINALS

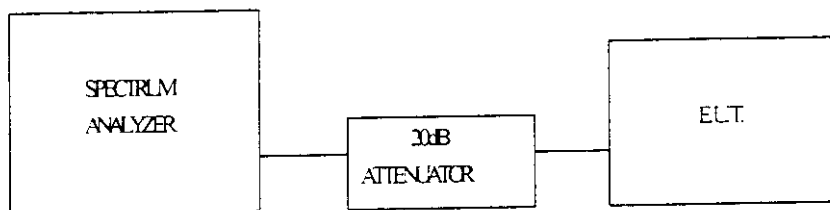

If the E.U.T. has an integral (non-detachable) antenna, the above test is performed as a radiated measurement and the result is reported as EIRP.

PROCESSING GAIN

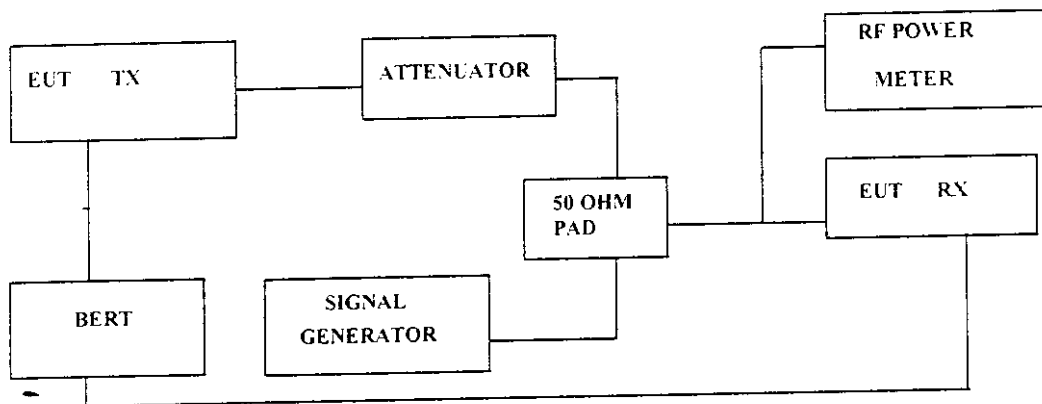

NOTE: This is a typical setup. The setup may vary slightly since many devices have BER test functions built into the device.

KTL - Certelecom Laboratories Inc.

FCC PART 15, SUBPART C
DIRECT SEQUENCE TRANSMITTERS
PROJECT NO.: 8R00161.1
ANNEX C

EQUIPMENT: 2.4 GHz Spread Spectrum Cordless Telephone Base

ANNEX C

TEST EQUIPMENT LIST

EQUIPMENT: 2.4 GHz Spread Spectrum Cordless Telephone Base**RADIO TEST EQUIPMENT LIST**

CAL CYCLE	EQUIPMENT	MANUFACTURER	MODEL	SERIAL	LAST CAL.	NEXT CAL.	
	Plotter	Hewlett Packard	7470A	2308A30807	NCR	NCR	
1 Year	Spectrum Analyzer-2	Hewlett Packard	8566B	1950A00400	Oct. 3/97	Oct. 3/98	
1 Year	Spectrum Analyzer Display-2	Hewlett Packard	85662A	1950A01177	Oct. 3/97	Oct. 3/98	
1 Year	Quasi Peak Adaptor-2	Hewlett Packard	85650A	2251A00620	Aug. 19/97	Aug. 19/98	
1 Year	Attenuator	Narda	765-20	9510	July 23/97	July 23/98	
1 Year	LISN(peripheral)	Tegam	95300-50	T-109014/15	July 25/97	July 25/98	
1 Year	Receiver	Rohde & Schwarz	ESVS-30	843710/002	Oct. 21/97	Oct. 21/98	
	Biconilog Antenna	EMCO	3143	1038	NCR	NCR	
2 Year	Horn Antenna	EMCO =2	3115	4336	Oct. 30/97	Oct. 30/99	
1 Year	Log Periodic Antenna	EMCO	LPA-25	1141	July 10/97	July 10/98	
1 Year	Biconical (1) Antenna	EMCO	3109	9204-2708	July 11/97	July 11/98	
1 Year	Low Noise Amplifier	Avantek	AWT-8035	1005	Oct. 24/97	Oct. 24/98	
1 Year	Low Noise Amplifier	DBS Microwave	DWT-13035	9623	Oct. 24/97	Oct. 24/98	
3 Year	Standard Gain Horn	Electro-Metres	SH-50 60-1	FA000479	July 29/97	July 29/00	
1 Year	Plotter	Hewlett Packard	7550A	FA001129	NCR	NCR	
1 Year	Spectrum Analyzer	Hewlett Packard	8565E	3804A00881	Feb. 27/98	Feb. 27/99	

NA: Not Applicable
NCR: No Cal Required