

# ENGINEERING TEST REPORT

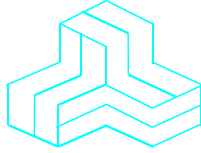

**Facsimile with 5.8GHz FHSS Cordless Telephone  
MODEL: KX-FPG391(xx)**

**FCC ID: ACJ96NKX-FPG391**

*Applicant:*

**Matsushita Electric Industrial Co., Ltd.**  
1006 Oaza Kadoma  
Kadoma Osaka 571  
Japan

*In Accordance With*

**Federal Communications Commission (FCC)  
Part 15, Subpart C, Section 15.247  
Frequency Hopping Spread Spectrum Transmitters  
Operating in the 5725 – 5850 MHz Band**

**UltraTech's File No.: PAN-051F15C247**

This Test report is Issued under the Authority of  
Tri M. Luu, Professional Engineer,  
Vice President of Engineering  
UltraTech Group of Labs



Date: May 10, 2004

Report Prepared by: Dan Huynh

Tested by: Mr. Hung Trinh, EMC/RFI Technician

Issued Date: May 10, 2004

Test Dates: April 23 – May 4, 2004

- *The results in this Test Report apply only to the sample(s) tested, and the sample tested is randomly selected.*
- *This report must not be used by the client to claim product endorsement by NVLAP or any agency of the US Government.*

## UltraTech

3000 Bristol Circle, Oakville, Ontario, Canada, L6H 6G4  
Tel.: (905) 829-1570 Fax.: (905) 829-8050

Website: [www.ultratech-labs.com](http://www.ultratech-labs.com), Email: [vic@ultratech-labs.com](mailto:vic@ultratech-labs.com), Email: [tri@ultratech-labs.com](mailto:tri@ultratech-labs.com)



31040/SIT



C-1376



46390-2049



200093-0



SL2-IN-E-1119R



00-034



## TABLE OF CONTENTS

<b>EXHIBIT 1.</b>	<b>INTRODUCTION.....</b>	<b>1</b>
1.1.	SCOPE .....	1
1.2.	RELATED SUBMITTAL(S)/GRANT(S).....	1
1.3.	NORMATIVE REFERENCES .....	1
<b>EXHIBIT 2.</b>	<b>PERFORMANCE ASSESSMENT .....</b>	<b>2</b>
2.1.	CLIENT INFORMATION .....	2
2.2.	EQUIPMENT UNDER TEST (EUT) INFORMATION .....	2
2.3.	EUT'S TECHNICAL SPECIFICATIONS .....	3
2.4.	LIST OF EUT'S PORTS.....	3
2.5.	ANCILLARY EQUIPMENT .....	3
<b>EXHIBIT 3.</b>	<b>EUT OPERATING CONDITIONS AND CONFIGURATIONS DURING TESTS.....</b>	<b>4</b>
3.1.	CLIMATE TEST CONDITIONS .....	4
3.2.	OPERATIONAL TEST CONDITIONS & ARRANGEMENT FOR TESTS .....	4
<b>EXHIBIT 4.</b>	<b>SUMMARY OF TEST RESULTS.....</b>	<b>5</b>
4.1.	LOCATION OF TESTS .....	5
4.2.	APPLICABILITY & SUMMARY OF EMC EMISSION TEST RESULTS .....	5
4.3.	MODIFICATIONS INCORPORATED IN THE EUT FOR COMPLIANCE PURPOSES .....	5
<b>EXHIBIT 5.</b>	<b>MEASUREMENTS, EXAMINATIONS &amp; TEST DATA FOR EMC EMISSIONS .....</b>	<b>6</b>
5.1.	TEST PROCEDURES .....	6
5.2.	MEASUREMENT UNCERTAINTIES .....	6
5.3.	MEASUREMENT EQUIPMENT USED .....	6
5.4.	ESSENTIAL/PRIMARY FUNCTIONS AS DECLARED BY THE MANUFACTURER.....	6
5.5.	COMPLIANCE WITH FCC PART 15 – GENERAL TECHNICAL REQUIREMENTS .....	7
5.6.	AC POWER LINE CONDUCTED EMISSIONS [47 CFR §15.107(a)].....	9
5.7.	HOPPING CHANNEL CARRIER FREQUENCY CHARACTERISTICS [47 CFR §§ 15.247(a)(1) & (a)(1)(iii)] .....	13
5.8.	PEAK OUTPUT POWER & EQUIVALENT ISOTROPIC RADIATED POWER (EIRP) [47 CFR § 15.247(b)].....	31
5.9.	RF EXPOSURE REQUIRMENTS [47 CFR §§ 15.247(b)(5) & 1.1310] .....	32
5.10.	TRANSMITTER BAND-EDGE & SPURIOUS CONDUCTED EMISSIONS [47 CFR § 15.247(c)] .....	35
5.11.	TRANSMITTER BAND-EDGE & SPURIOUS RADIATED EMISSIONS AT 3 METERS [47 CFR §§ 15.247(c), 15.209 & 15.205] .....	46
<b>EXHIBIT 6.</b>	<b>MEASUREMENT UNCERTAINTY.....</b>	<b>53</b>
6.1.	LINE CONDUCTED EMISSION MEASUREMENT UNCERTAINTY.....	53
6.2.	RADIATED EMISSION MEASUREMENT UNCERTAINTY .....	54
<b>EXHIBIT 7.</b>	<b>MEASUREMENT METHODS.....</b>	<b>55</b>
7.1.	GENERAL TEST CONDITIONS.....	55
7.2.	METHOD OF MEASUREMENTS - AC MAINS CONDUCTED EMISSIONS .....	56
7.3.	EQUIVALENT ISOTROPIC RADIATED POWER (EIRP).....	57
7.4.	SPURIOUS EMISSIONS (CONDUCTED & RADIATED).....	60
7.5.	ALTERNATIVE TEST PROCEDURES .....	63

## EXHIBIT 1. INTRODUCTION

### 1.1. SCOPE

<b>Reference:</b>	FCC Part 15, Subpart C, Section 15.247:2003; FCC Public Notice DA 00-705
<b>Title:</b>	Telecommunication – 47 Code of Federal Regulations (CFR), Part 15
<b>Purpose of Test:</b>	To gain FCC Certification Authorization for Frequency Hopping Spread Spectrum Transmitters Operating in the 5725 – 5850 MHz Band .
<b>Test Procedures:</b>	Both conducted and radiated emissions measurements were conducted in accordance with American National Standards Institute ANSI C63.4 - American National Standard for Methods of Measurement of Radio-Noise Emissions from Low-Voltage Electrical and Electronic Equipment in the Range of 9 kHz to 40 GHz.
<b>Environmental Classification:</b>	[ x ] Commercial, industrial or business environment [ x ] Residential environment

### 1.2. RELATED SUBMITTAL(S)/GRANT(S)

None.

### 1.3. NORMATIVE REFERENCES

Publication	Year	Title
47 CFR Parts 0-19	2003	Code of Federal Regulations – Telecommunication
ANSI C63.4	2003	American National Standard for Methods of Measurement of Radio-Noise Emissions from Low-Voltage Electrical and Electronic Equipment in the Range of 9 kHz to 40 GHz
CISPR 22 & EN 55022	2002 2003	Limits and Methods of Measurements of Radio Disturbance Characteristics of Information Technology Equipment
CISPR 16-1	1999	Specification for Radio Disturbance and Immunity measuring apparatus and methods
FCC Public Notice DA 00-705	2000	Filing and Measurement Guidelines for Frequency Hopping Spread Spectrum Systems

---

**ULTRATECH GROUP OF LABS**

3000 Bristol Circle, Oakville, Ontario, Canada L6H 6G4  
Tel. #: 905-829-1570, Fax. #: 905-829-8050, Email: [vic@ultratech-labs.com](mailto:vic@ultratech-labs.com), Website: <http://www.ultratech-labs.com>

File #: PAN-051F15C247

May 10, 2004

*All test results contained in this engineering test report are traceable to National Institute of Standards and Technology (NIST)*

## EXHIBIT 2. PERFORMANCE ASSESSMENT

### 2.1. CLIENT INFORMATION

APPLICANT	
<b>Name:</b>	Matsushita Electric Industrial Co., Ltd.
<b>Address:</b>	1006 Oaza Kadoma Kadoma Osaka 571 Japan
<b>Contact Person:</b>	Richard Mullen Phone #: 201-348-7758 Fax #: 201-392-4564 Email Address: <a href="mailto:mullenr@us.panasonic.com">mullenr@us.panasonic.com</a>

MANUFACTURER	
<b>Name:</b>	Panasonic Communications Co., Ltd.
<b>Address:</b>	1-62, 4-chome, Minoshima, Hakata-ku Fukuoka, Fukuoka-ken 812-8531 Japan
<b>Contact Person:</b>	Mr. Kunihiko Nawata Phone #: +81-92-477-1405 Fax #: +81-92-477-1487 Email Address: <a href="mailto:nawata.kunihiko@jp.panasonic.com">nawata.kunihiko@jp.panasonic.com</a>

### 2.2. EQUIPMENT UNDER TEST (EUT) INFORMATION

The following information (with the exception of the Date of Receipt) has been supplied by the applicant.

<b>Brand Name:</b>	Panasonic
<b>Product Name:</b>	Facsimile with 5.8GHz FHSS Cordless Telephone
<b>Model Name or Number:</b>	KX-FPG391(xx)
<b>Serial Number:</b>	Pre- Production
<b>Type of Equipment:</b>	Frequency Hopping Spread Spectrum Transmitters
<b>Input Power Supply Type:</b>	AC 120V 60Hz
<b>Primary User Functions of EUT:</b>	Facsimile with Cordless Telephone

#### ULTRATECH GROUP OF LABS

3000 Bristol Circle, Oakville, Ontario, Canada L6H 6G4  
Tel. #: 905-829-1570, Fax. #: 905-829-8050, Email: [vic@ultratech-labs.com](mailto:vic@ultratech-labs.com), Website: <http://www.ultratech-labs.com>

File #: PAN-051F15C247  
May 10, 2004

*All test results contained in this engineering test report are traceable to National Institute of Standards and Technology (NIST)*

### 2.3. EUT'S TECHNICAL SPECIFICATIONS

<b>TRANSMITTER</b>	
<b>Equipment Type:</b>	<input type="checkbox"/> Portable <input checked="" type="checkbox"/> Mobile
<b>Intended Operating Environment:</b>	<input checked="" type="checkbox"/> Commercial, industrial or business environment <input checked="" type="checkbox"/> Residential environment
<b>Power Supply Requirement:</b>	AC 120V 60Hz
<b>RF Output Power Rating:</b>	20.91 dBm (0.123 W) Peak Conducted Power
<b>Operating Frequency Range:</b>	5759.70240 - 5838.18697 MHz
<b>RF Output Impedance:</b>	50 Ohm
<b>Channel Spacing:</b>	891.87 kHz
<b>20 dB Bandwidth:</b>	625.25 kHz
<b>Modulation Type:</b>	FM (2-FSK)
<b>Channel Occupancy:</b>	6.61 msec within 30 second period
<b>Emission Designation:</b>	Frequency Hopping Spread Spectrum
<b>Antenna Connector Type:</b>	Permanently attached, antenna cable is soldered and fixed at EUT
<b>Antenna Description:</b>	Manufacturer: SANSEI ELECTRIC CO.,LTD. , Miyazaki Matsushita Electric Co.,Ltd.  Type: Colliner Antenna  Model: PQSA10148WA-RG(Left-ANT, SANSEI) PQSA10149XA-RG(Right-ANT, SANSEI)  Frequency Range: 5.759 – 5.838 GHz  Gain: 4dBi (nominal)

### 2.4. LIST OF EUT'S PORTS

Port Number	EUT's Port Description	Number of Identical Ports	Connector Type	Cable Type (Shielded/Non-shielded)
1	Telephone Line	1	RJ11 (USA) CA11 (Canada)	1.8m (Non-Shielded)

### 2.5. ANCILLARY EQUIPMENT

The EUT was tested while connected to the following representative configuration of ancillary equipment necessary to exercise the ports during tests:

None.

## EXHIBIT 3. EUT OPERATING CONDITIONS AND CONFIGURATIONS DURING TESTS

### 3.1. CLIMATE TEST CONDITIONS

The climate conditions of the test environment are as follows:

Temperature:	21°C
Humidity:	51%
Pressure:	102 kPa
Power Input Source:	AC 120V 60Hz

### 3.2. OPERATIONAL TEST CONDITIONS & ARRANGEMENT FOR TESTS

<b>Operating Modes:</b>	<ul style="list-style-type: none"> <li>▪ Each of lowest, middle and highest channel frequencies transmits continuously for emissions measurements.</li> <li>▪ The EUT operates in normal Frequency Hopping mode for occupancy duration and frequency separation.</li> </ul>
<b>Special Test Software:</b>	None.
<b>Special Hardware Used:</b>	None.
<b>Transmitter Test Antenna:</b>	The EUT is tested with the antenna fitted in a manner typical of normal intended use as integral antenna equipment.

<b>Transmitter Test Signals</b>	
<b>Frequency Band(s):</b>	5759.70240 – 5838.18697 MHz
<b>Frequency(ies) Tested:</b> (Near lowest, near middle & near highest frequencies in the frequency range of operation.)	<ul style="list-style-type: none"> <li>▪ 5759.70240 MHz</li> <li>▪ 5798.05084 MHz</li> <li>▪ 5838.18697 MHz</li> </ul>
<b>RF Power Output (measured maximum output power):</b>	20.91 dBm (0.123 W) Peak Conducted Power
<b>Normal Test Modulation:</b>	FM (2-FSK) with 576 kbps data rate
<b>Modulating Signal Source:</b>	Internal

## EXHIBIT 4. SUMMARY OF TEST RESULTS

### 4.1. LOCATION OF TESTS

All of the measurements described in this report were performed at Ultratech Group of Labs located in the city of Oakville, Province of Ontario, Canada.

- AC Powerline Conducted Emissions were performed in UltraTech's shielded room, 24'(L) by 16'(W) by 8'(H).
- Radiated Emissions were performed at the Ultratech's 3 Meter Open Field Test Site (OFTS) situated in the Town of Oakville, province of Ontario.

The above sites have been calibrated in accordance with ANSI C63.4, and found to be in compliance with the requirements of Sec. 2.948 of the FCC Rules. The descriptions and site measurement data of the Oakville Open Field Test Site has been filed with FCC office (FCC File No.: 31040/SIT 1300B3) and Industry Canada office (Industry Canada File No.: IC2049). Last Date of Site Calibration: February 17, 2004.

### 4.2. APPLICABILITY & SUMMARY OF EMC EMISSION TEST RESULTS

Reference	Test Requirements	Compliance (Yes/No)
Public Notice DA 00-1407	Part 15 Unlicensed Modular Transmitter Approval	Not Applicable
15.107(a)	AC Power Line Conducted Emissions Measurements	Yes
15.247(a)(1) & 15.247(a)(1)(ii)	Frequency Hopping Systems Characteristics	Yes
15.247(b)(1)	Peak Output Power	Yes
15.247(b)(5), 1.1307, 1.1310, 2.1091 & 2.1093	RF Exposure Limit	Yes
15.247(c)	Band-Edge and RF Conducted Spurious Emissions at the Transmitter Antenna Terminal	Yes
15.247(c), 15.209 & 15.205	Transmitter Radiated Emissions	Yes

The digital circuit portion of the EUT has been tested and verified to comply with FCC Part 15, Subpart B, Class B Digital Devices. The engineering test report can be provided upon requests.

### 4.3. MODIFICATIONS INCORPORATED IN THE EUT FOR COMPLIANCE PURPOSES

None.

---

---

## **EXHIBIT 5. MEASUREMENTS, EXAMINATIONS & TEST DATA FOR EMC EMISSIONS**

### **5.1. TEST PROCEDURES**

This section contains test results only. Details of test methods and procedures can be found in Exhibit 7 of this report, ANSI C63-4 and FCC Public Notice @ DA 00-705 (March 30, 2000) – Filing and Measurement Guidelines for Frequency Hopping Spread Spectrum Systems.

### **5.2. MEASUREMENT UNCERTAINTIES**

The measurement uncertainties stated were calculated in accordance with requirements of UKAS Document NIS 81 with a confidence level of 95%. Please refer to Exhibit 6 for Measurement Uncertainties.

### **5.3. MEASUREMENT EQUIPMENT USED**

The measurement equipment used complied with the requirements of the Standards referenced in the Methods & Procedures ANSI C63.4, FCC 15.247 and CISPR 16-1.

### **5.4. ESSENTIAL/PRIMARY FUNCTIONS AS DECLARED BY THE MANUFACTURER**

Facsimile with Cordless Telephone.

**5.5. COMPLIANCE WITH FCC PART 15 – GENERAL TECHNICAL REQUIREMENTS**

FCC Section	FCC Rules	
15.31	The hopping function must be disabled for tests, which should be performed with the EUT transmitting on the number of frequencies specified in this Section. The measurements made at the upper and lower ends of the band of operation should be made with the EUT tuned to the highest and lowest available channels.	Hopping function was disabled during testing
15.203	<p>Described how the EUT complies with the requirement that either its antenna is permanently attached, or that it employs a unique antenna connector, for every antenna proposed for use with the EUT.</p> <p>The exception is in those cases where EUT must be professionally installed. In order to demonstrate that professional installation is required, the following 3 points must be addressed:</p> <p>(a) The application (or intended use) of the EUT                      (b) The installation requirements of the EUT                      (c) The method by which the EUT will be marketed</p>	The antenna is permanently attached.
15.204	<p>Provided the information for every antenna proposed for use with the EUT:</p> <p>(a) type (e.g. Yagi, patch, grid, dish, etc...),                      (b) manufacturer and model number                      (c) gain with reference to an isotropic radiator</p>	Refer to Section 2.3 of this test report for details of antenna information
15.247(a)	Description of how the EUT meets the definition of a frequency hopping spread spectrum, found in Section 2.1. Based on the technical description.	Refer to FHSS Description
15.247(a)	<p><u>Pseudo Frequency Hopping Sequence:</u>                      Describe how the hopping sequence is generated. Provide an example of the hopping sequence channels, in order to demonstrate that the sequence meets the requirements specified in the definition of a frequency hopping spread spectrum system, found in Section 2.1</p>	Refer to FHSS Description
15.247(a)	<p><u>Equal Hopping Frequency Use:</u>                      Describe how each individual EUT meets the requirement that each of its hopping channels is used equally on average (e.g. that each new transmission event begins on the next channel in the hopping sequence after final channel used in the previous transmission events).</p>	Refer to FHSS Description

FCC Section	FCC Rules	Laboratory's Comments
15.247(g)	Describe how the EUT complies with the requirement that it be designed to be capable of operating as a true frequency hopping system	Refer to FHSS Description
15.247(h)	Describe how the EUT complies with the requirement that it not have the ability to coordinated with other FHSS is an effort to avoid the simultaneous occupancy of individual hopping frequencies by multiple transmitters	Refer to FHSS Description
Public Notice DA 00-705	<u>System Receiver Input Bandwidth:</u> Describe how the associated receiver(s) complies with the requirement that its input bandwidth (either RF or IF) matches the bandwidth of the transmitted signal.	Refer to FHSS Description
Public Notice DA 00-705	<u>System Receiver Hopping Capability:</u> Describe how the associated receiver(s) has the ability to shift frequencies in synchronization with the transmitted signals	Refer to FHSS Description

## 5.6. AC POWER LINE CONDUCTED EMISSIONS [47 CFR §15.107(a)]

### 5.6.1. Limits

The equipment shall meet the limits of the following table:

Frequency of emission (MHz)	Class B Conducted Limits (dB $\mu$ V)		Measuring Bandwidth
	Quasi-peak	Average	
0.15–0.5 .....	66 to 56* .....	56 to 46*	RBW = 9 kHz VBW $\geq$ 9 kHz for QP VBW = 1 Hz for Average
0.5–5 .....	56 .....	46	
5–30 .....	60 .....	50	

\* Decreases linearly with logarithm of the frequency

### 5.6.2. Method of Measurements

Refer to Section 7.2 of this test report & ANSI C63-4

### 5.6.3. Test Arrangement

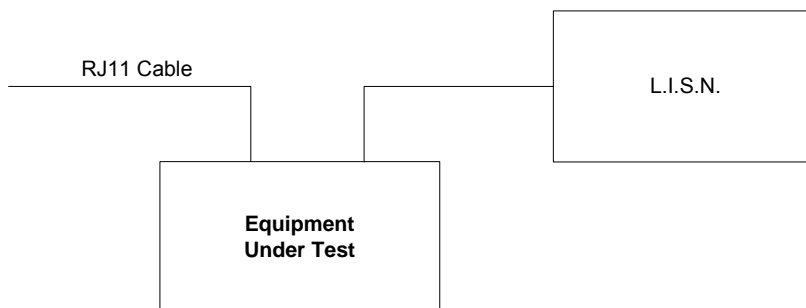

### 5.6.4. Test Equipment List

Test Instruments	Manufacturer	Model No.	Serial No.	Frequency Range
Spectrum Analyzer/ EMI Receiver	Hewlett Packard	HP 8593EM	3412A00103	9 kHz – 26.5 GHz
Transient Limiter	Hewlett Packard	11947A	310701998	9 kHz – 200 MHz 10 dB attenuation
L.I.S.N.	EMCO	3825/2	89071531	9 kHz – 200 MHz 50 Ohms / 50 $\mu$ H
24'(L) x 16'(W) x 8'(H) RF Shielded Chamber	Braden Shielding	...	...	...

5.6.5. Test Data

Frequency (MHz)	RF Level (dB $\mu$ V)	Receiver Detector (P/QP/AVG)	QP Limit (dB $\mu$ V)	AVG Limit (dB $\mu$ V)	Margin (dB)	Pass/ Fail	Line Tested (L1/L2)
0.170200	43.3	QP	65.0	55.0	-21.7	Pass	L1
0.170200	35.7	AVG	65.0	55.0	-19.3	Pass	L1
0.512325	34.4	QP	56.0	46.0	-21.6	Pass	L1
0.512325	29.3	AVG	56.0	46.0	-16.7	Pass	L1
1.201613	30.5	QP	56.0	46.0	-25.5	Pass	L1
1.201613	23.6	AVG	56.0	46.0	-22.4	Pass	L1
0.170212	42.5	QP	65.0	55.0	-22.5	Pass	L2
0.170212	36.3	AVG	65.0	55.0	-18.7	Pass	L2
0.512324	33.7	QP	56.0	46.0	-22.3	Pass	L2
0.512324	28.7	AVG	56.0	46.0	-17.3	Pass	L2
1.201611	33.2	QP	56.0	46.0	-22.8	Pass	L2
1.201611	29.2	AVG	56.0	46.0	-16.8	Pass	L2

Note: See the following test data plots (1 – 2) for detailed measurements

Plot 1:  
 AC Power Line Conducted Emissions  
 Line Voltage: 120 Vac 60 Hz  
 Line Tested: L1



13:28:47 JAN 06, 2004

Signal	Freq (MHz)	PK Amp	QP Amp	AV Amp	AV <sub>Δ</sub> L2
1	0.170200	45.0	43.3	35.7	-19.4
2	0.512325	36.0	34.4	29.3	-16.7
3	1.201613	33.3	30.5	23.6	-22.4

MARKER  
 260 kHz  
 43.08 dB<sub>μ</sub>V

ACTV DET: PEAK  
 MEAS DET: PEAK QP AVG  
 MKR 260 kHz  
 43.08 dB<sub>μ</sub>V

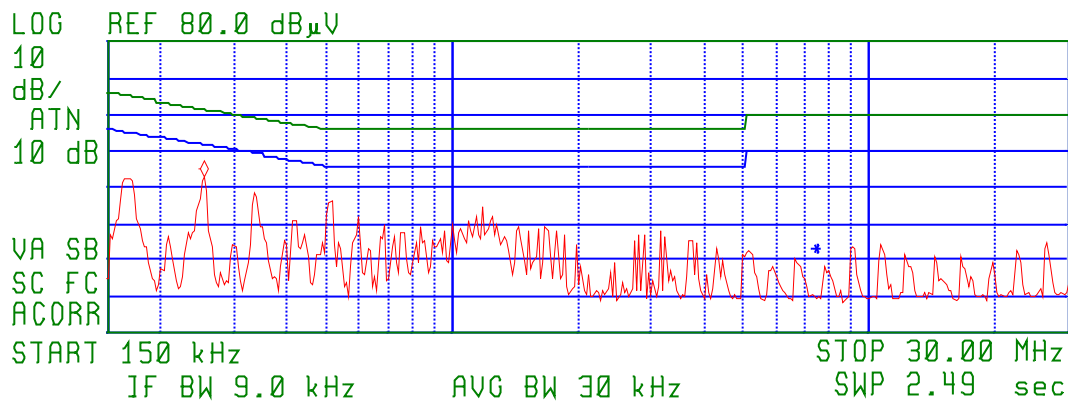

Plot 2:  
 AC Power Line Conducted Emissions  
 Line Voltage: 120 Vac 60 Hz  
 Line Tested: L2



13:28:47 JAN 06, 2004

Signal	Freq (MHz)	PK Amp	QP Amp	AV Amp	AV <sub>Δ</sub> L2
1	0.170212	44.3	42.5	36.3	-18.7
2	0.512324	35.0	33.7	28.7	-17.3
3	1.201611	35.8	33.2	29.2	-16.8

MARKER  
 260 kHz  
 42.28 dB<sub>μ</sub>V

ACTV DET: PEAK  
 MEAS DET: PEAK QP AVG  
 MKR 260 kHz  
 42.28 dB<sub>μ</sub>V

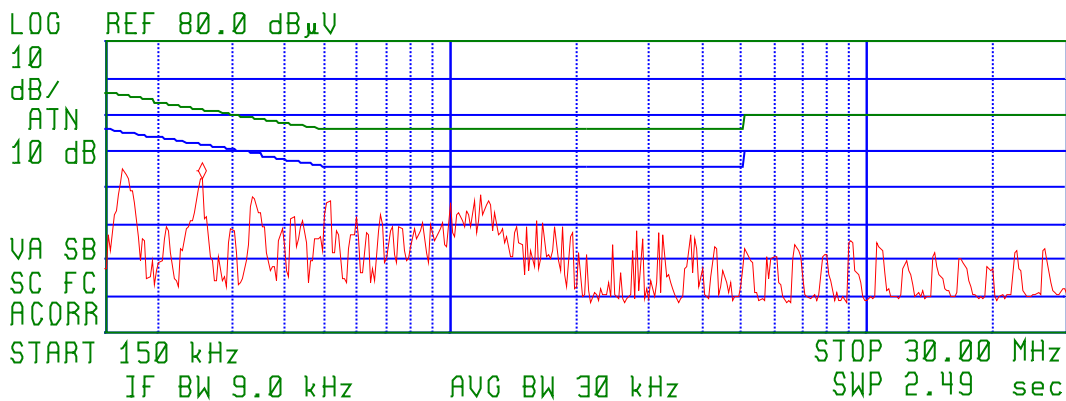

## 5.7. HOPPING CHANNEL CARRIER FREQUENCY CHARACTERISTICS [47 CFR §§ 15.247(a)(1) & (a)(1)(iii)]

### 5.7.1. Limits

- § 15.247(a)(1): Frequency hopping systems shall have hopping channel carrier frequencies separated by a minimum of 25 kHz or the 20 dB bandwidth of the hopping channel, whichever is greater. The system shall hop to channel frequencies that are selected at the system-hopping rate from a pseudo randomly ordered list of hopping frequencies. Each frequency must be used equally on the average by each transmitter. The system receivers shall have input bandwidths that match the hopping channel bandwidths of their corresponding transmitters and shall shift frequencies in synchronization with the transmitted signals.
- § 15.247(a)(1)(ii): Frequency hopping systems in the 5725–5850 MHz band shall use at least 75 hopping frequencies. The maximum 20dB bandwidth of the hopping channel is 1 MHz. The average time of occupancy on any frequency shall not be greater than 0.4 seconds within a 30 second period.

### 5.7.2. Method of Measurements

ANSI C63-4 and Public Notice DA 00-705

#### Carrier Frequency Separation:

The hopping function of the EUT is enabled. Use the spectrum analyzer setting as follows:

- Span = wide enough to capture the peaks of two adjacent channels
- RBW = 1% of the span
- VBW  $\geq$  RBW
- Sweep = Auto
- Detector = peak
- Trace = max hold

#### Number of hopping frequency:

The hopping function of the EUT is enabled. Use the spectrum analyzer setting as follows:

- Span = the frequency band of operation
- RBW = 1% of the span
- VBW  $\geq$  RBW
- Sweep = Auto
- Detector = peak
- Trace = max hold

**Time of Occupancy (Dwell Time):**

The hopping function of the EUT is enabled. Use the spectrum analyzer setting as follows:

- Span = 0 Hz centered on a hopping channel
- RBW = 1 MHz
- VBW ≥ RBW
- Sweep = as necessary to capture the entire dwell time per hopping channel
- Detector = peak
- Trace = max hold

If possible, use the marker-delta function to determine the dwell time. If this value varies with different modes of operation (e.g. data rate modulation format, etc.), repeat this test for each variation. The limit is specified in one of the subparagraphs of this Section. Submit this plot(s). An oscilloscope may be used instead of a spectrum analyzer.

**20 dB Bandwidth:**

Use the spectrum analyzer setting as follows:

- Span = approximately 2 to 3 times the 20 dB bandwidth, centered on a hopping channel
- RBW = 1% of the 20 dB bandwidth
- VBW ≥ RBW
- Sweep = auto
- Detector = peak
- Trace = max hold
- The transmitter shall be transmitting at its maximum data rate.
- Allow the trace to stabilize.
- Use the marker-to-peak function to set the marker to the peak of the emission.
- Use the marker-delta function to measure 20 dB down on both sides of the emission.
- The 20 dB BW is the delta reading in frequency between two markers.

**5.7.3. Test Arrangement**

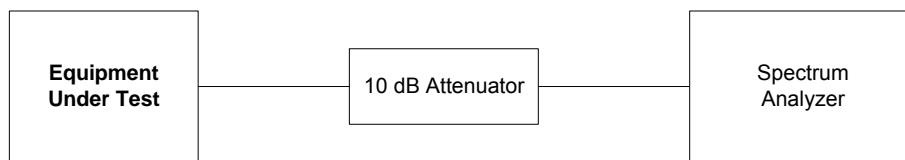

**5.7.4. Test Equipment List**

Test Instruments	Manufacturer	Model or P/N	Serial No.	Frequency Range
Spectrum Analyzer	Rohde & Schwarz	FSEK20/B4/B21	834157/005	9 kHz – 40 GHz
Attenuator	Macom	3082-6193-10	--	--

**5.7.5. Test data**

<b>Test Description</b>	<b>FCC Specifications</b>	<b>Measured Values</b>	<b>Comments</b>
Carrier Frequency Separation	Minimum of 25 kHz or 20dB BW whichever is greater.	891.78 kHz	Complies, see plot 3 for detailed measurements.
Number of Hopping Frequencies	At least 75 hopping frequencies.	75 hopping frequencies	Complies, see plots 4 to 7 for detailed measurements.
20 dB Bandwidth	The maximum 20dB bandwidth of the hopping channel is 1 MHz	625.25 kHz	Complies, see plots 8 to 10 for detailed measurements.
Time of Occupancy (Dwell Time)	The average time of occupancy on any frequency shall not be greater than 0.4 seconds within a 30 second period.	6.61 msec within a 30 second period	Complies, see plots 11 to 16 for detailed measurements.

Plot 3:  
Carrier Frequency Separation

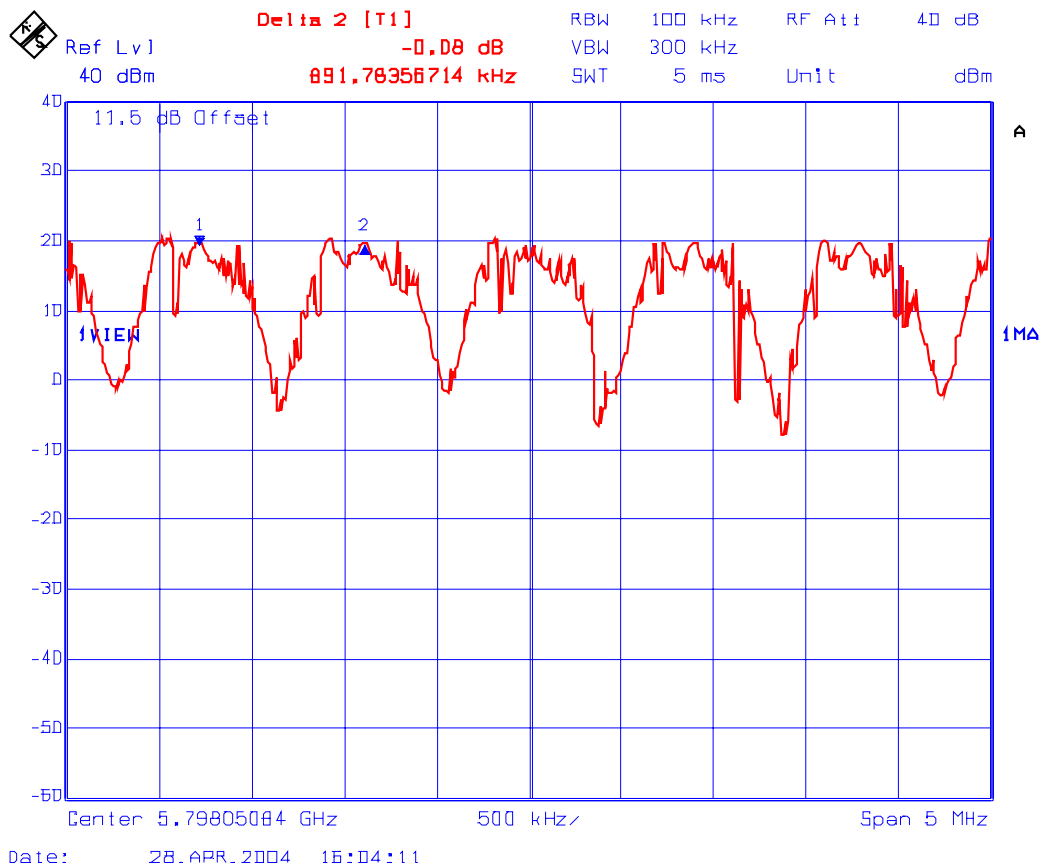

Plot 4:  
 Number of Hopping Frequencies  
 75 Hopping Frequencies (from 5.725 – 5.85 GHz)

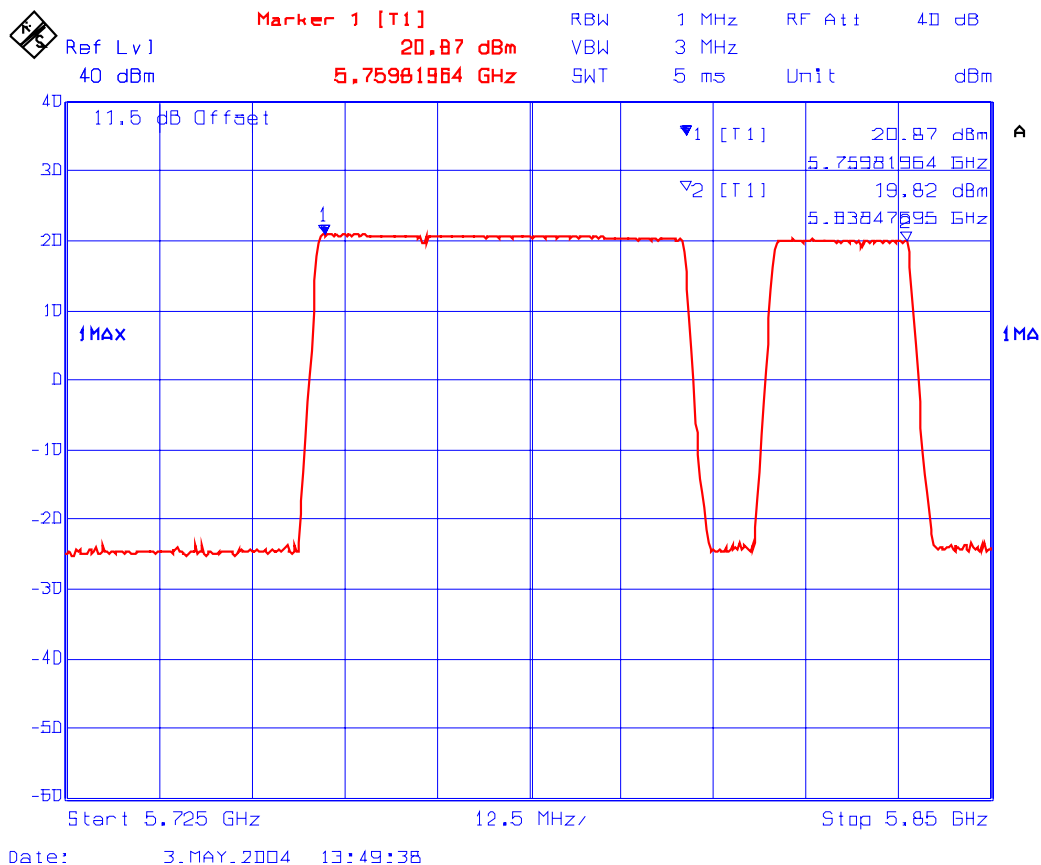

Plot 5:  
 Number of Hopping Frequencies  
 23 hopping frequencies (from 5759.7024 – 5780 MHz band)

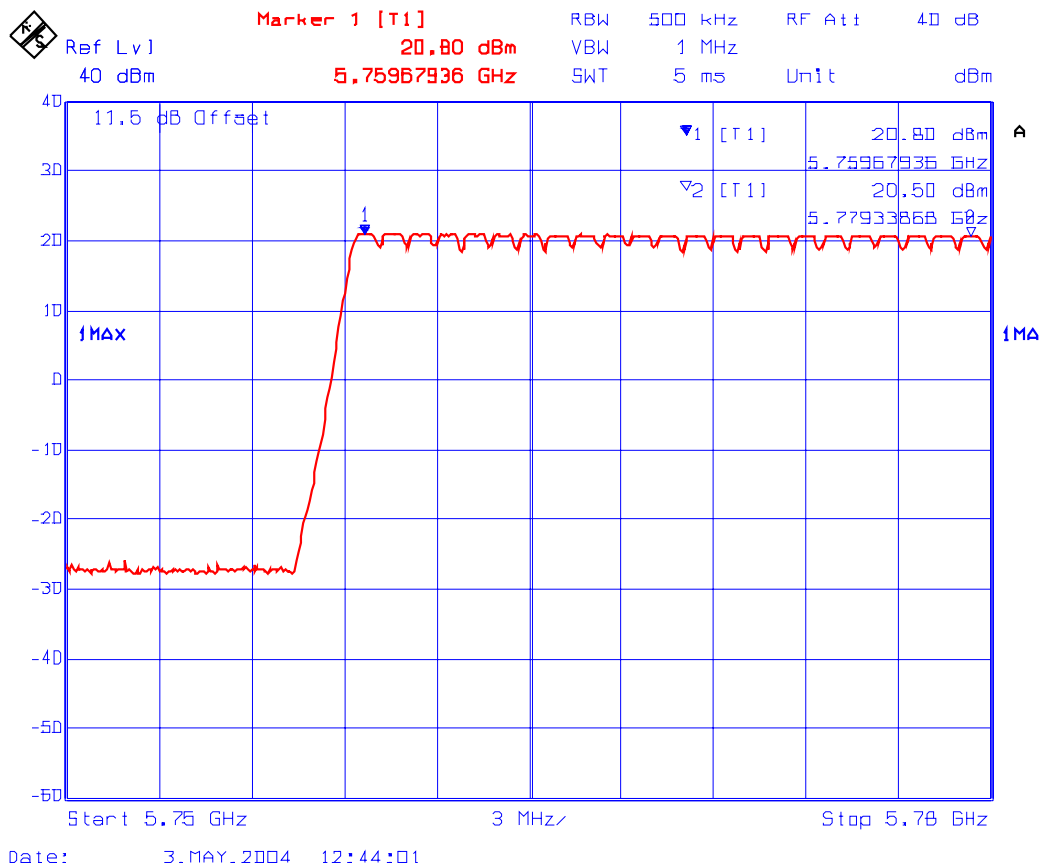

Plot 6:  
 Number of Hopping Frequencies  
 32 hopping frequencies (from 5779 – 5810 MHz)

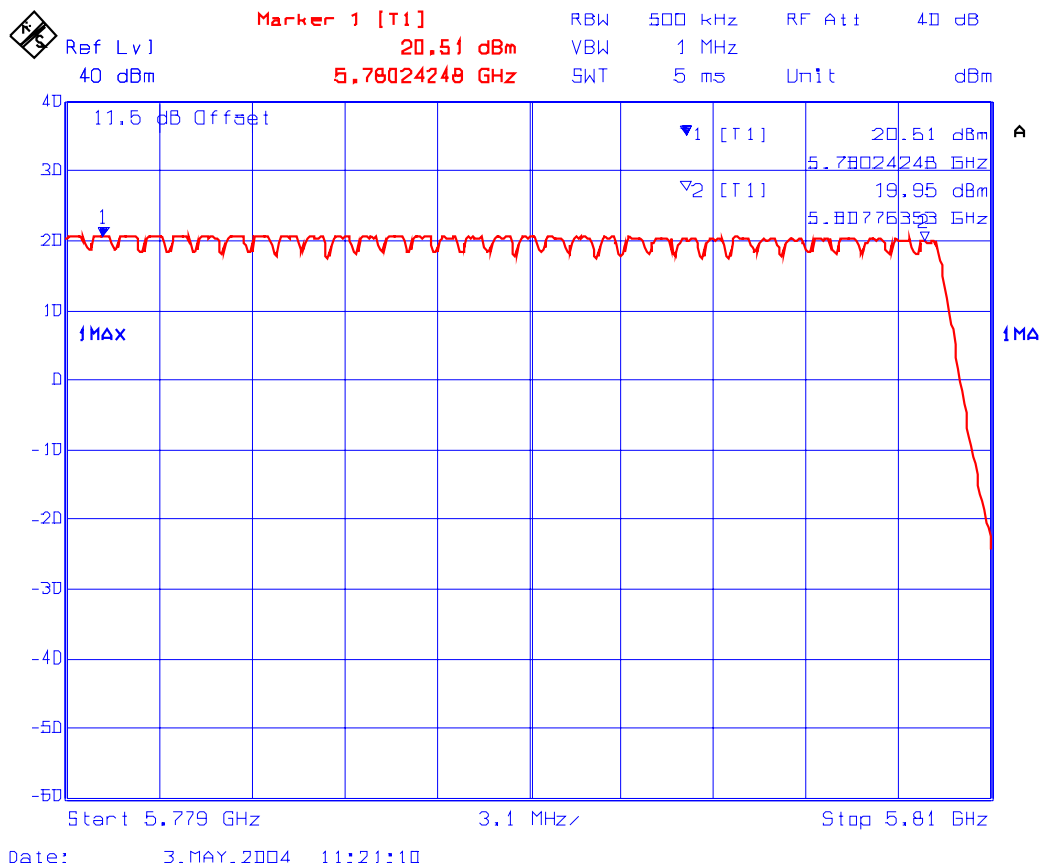

Plot 7:  
 Number of Hopping Frequencies  
 20 hopping frequencies (from 5800 – 5840 MHz)

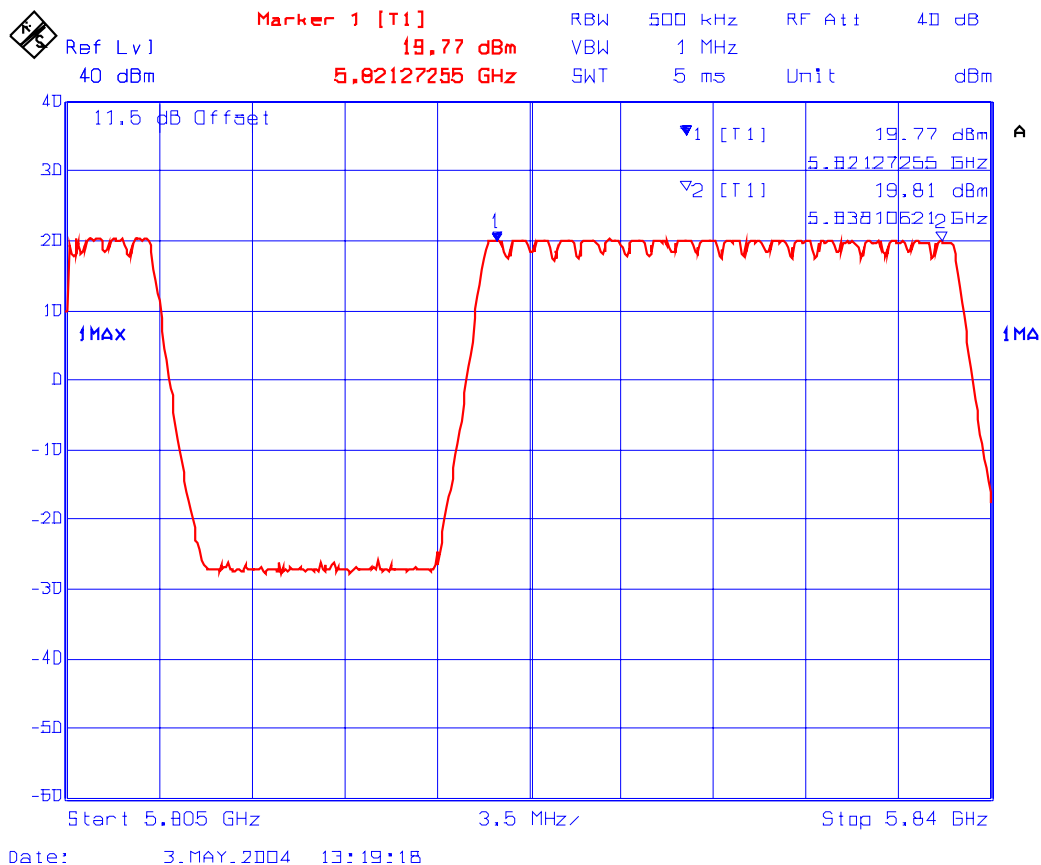

Plot 8:  
20 dB Bandwidth  
Test Frequency: 5759.70240 MHz (CH 00)

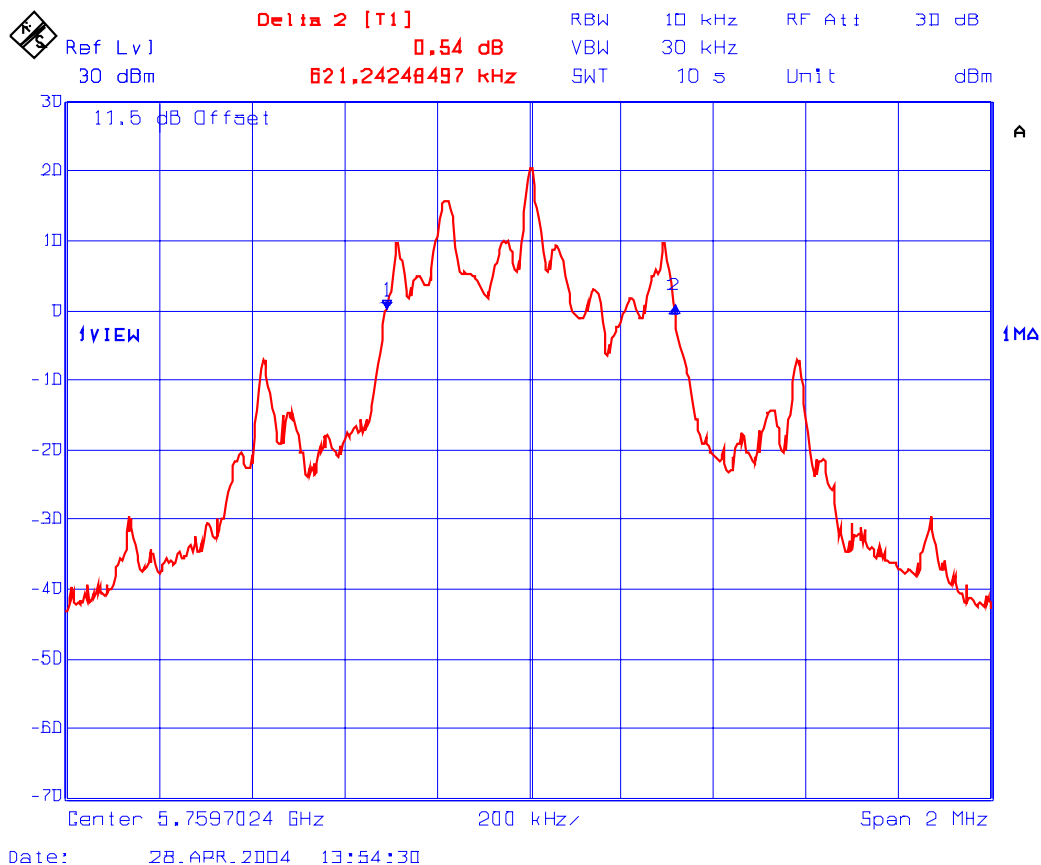

Plot 9:  
20 dB Bandwidth  
Test Frequency: 5798.05084 MHz (CH 43)

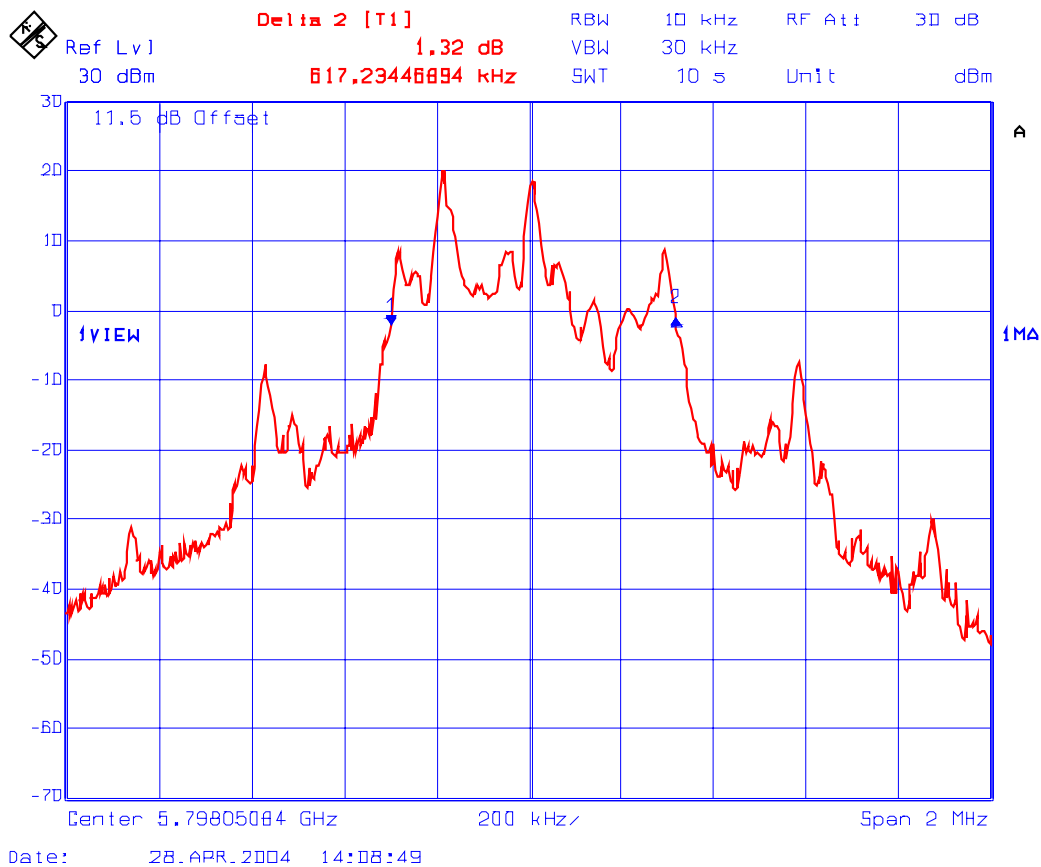

**ULTRATECH GROUP OF LABS**

3000 Bristol Circle, Oakville, Ontario, Canada L6H 6G4  
Tel. #: 905-829-1570, Fax. #: 905-829-8050, Email: [vic@ultratech-labs.com](mailto:vic@ultratech-labs.com), Website: <http://www.ultratech-labs.com>

File #: PAN-051F15C247  
May 10, 2004

All test results contained in this engineering test report are traceable to National Institute of Standards and Technology (NIST)

Plot 10:  
20 dB Bandwidth  
Test Frequency: 5838.18697 MHz (CH 88)

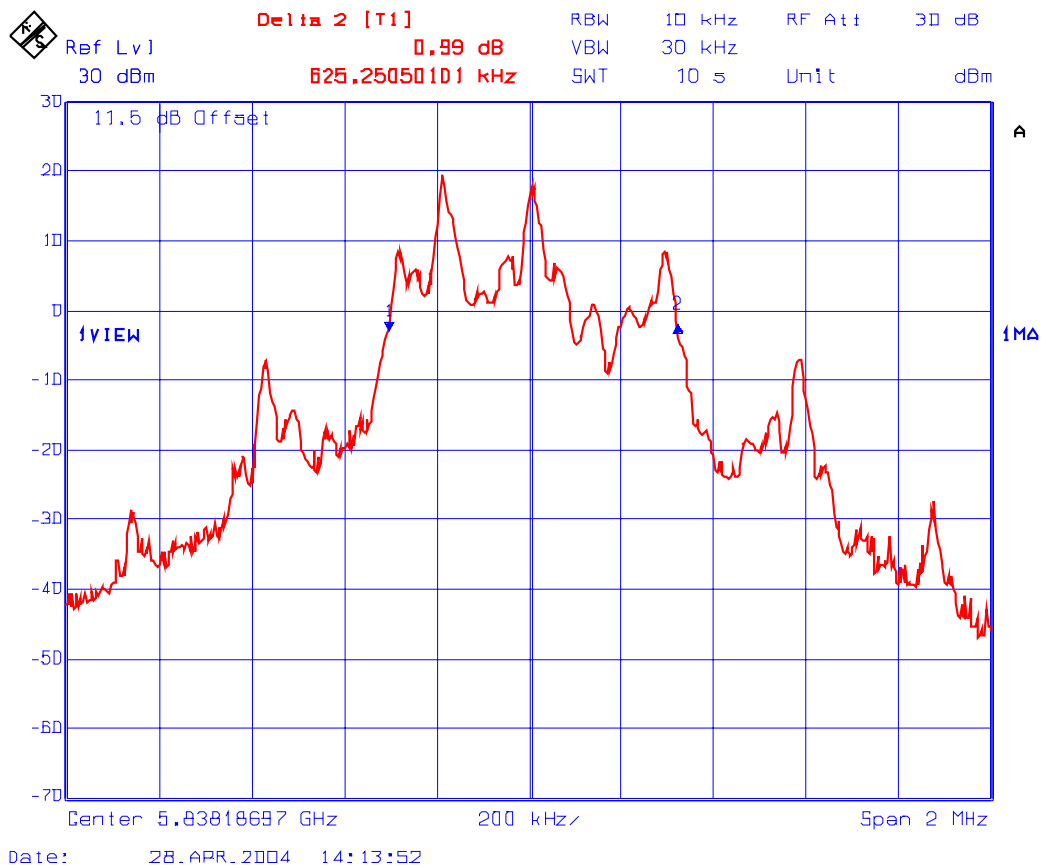

**ULTRATECH GROUP OF LABS**

3000 Bristol Circle, Oakville, Ontario, Canada L6H 6G4  
Tel. #: 905-829-1570, Fax. #: 905-829-8050, Email: [vic@ultratech-labs.com](mailto:vic@ultratech-labs.com), Website: <http://www.ultratech-labs.com>

File #: PAN-051F15C247  
May 10, 2004

All test results contained in this engineering test report are traceable to National Institute of Standards and Technology (NIST)

Plot 11:  
Time of Occupancy  
Test Frequency: 5759.7024 MHz (CH 00)

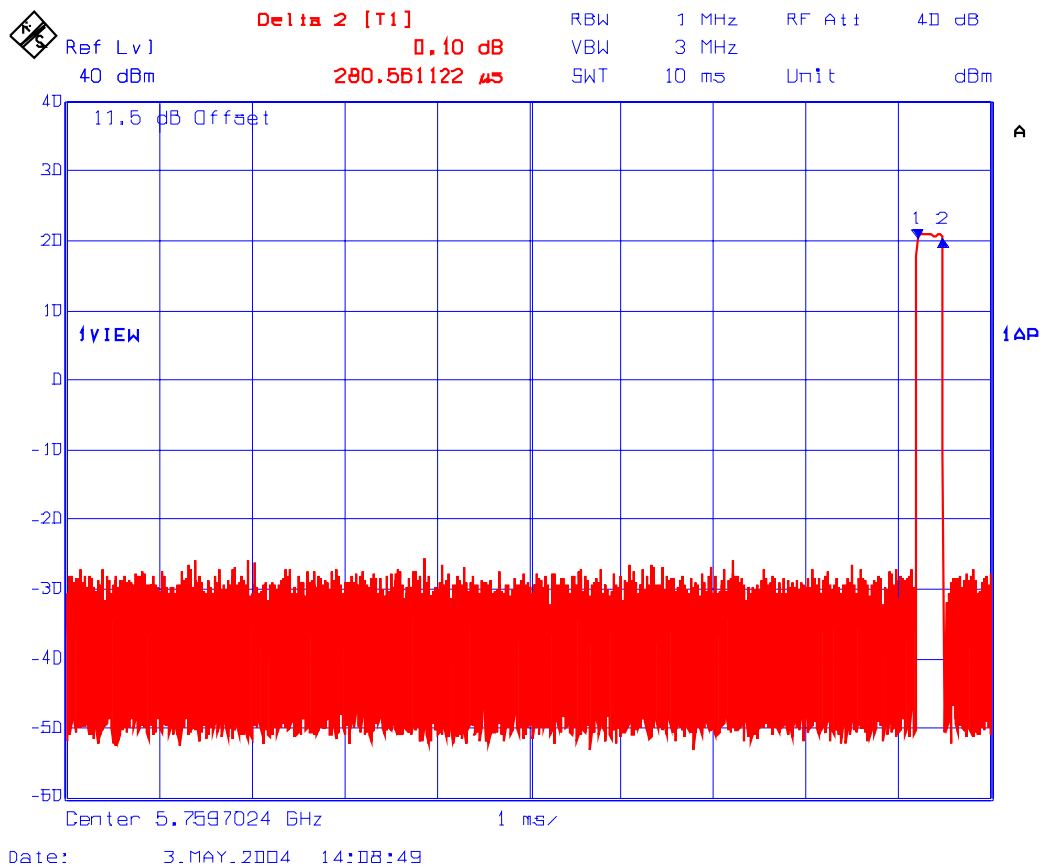

Dwell Time @ 5759.7024 MHz = 280.56 μsec

Plot 12:  
 Time of Occupancy  
 Test Frequency: 5759.7024 MHz (CH 00)

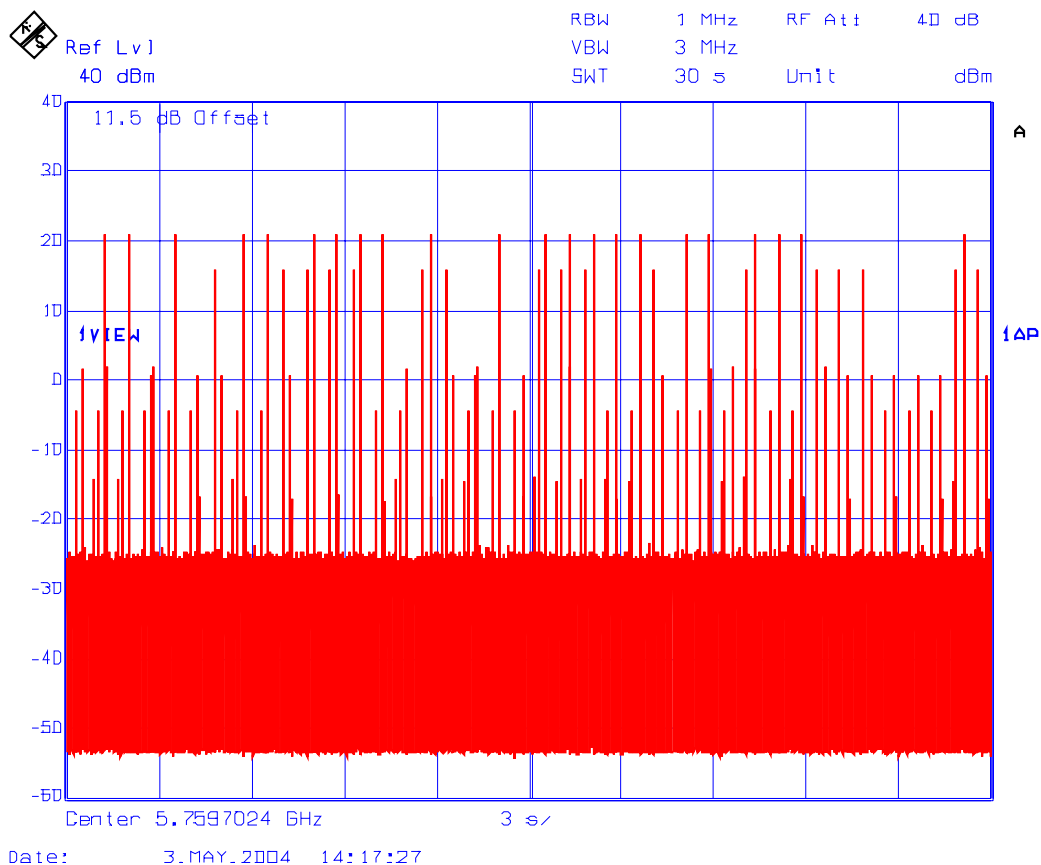

$$\begin{aligned}
 \text{Average time of occupancy in 30 s} &= (\text{Dwell Time @ 5759.7024 MHz}) \times (\text{number of hops in 30 s}) \\
 &= 280.56 \mu\text{sec} \times 22 \\
 &= 6.17 \text{ msec}
 \end{aligned}$$

Plot 13:  
Time of Occupancy  
Test Frequency: 5798.05084 MHz (CH 43)

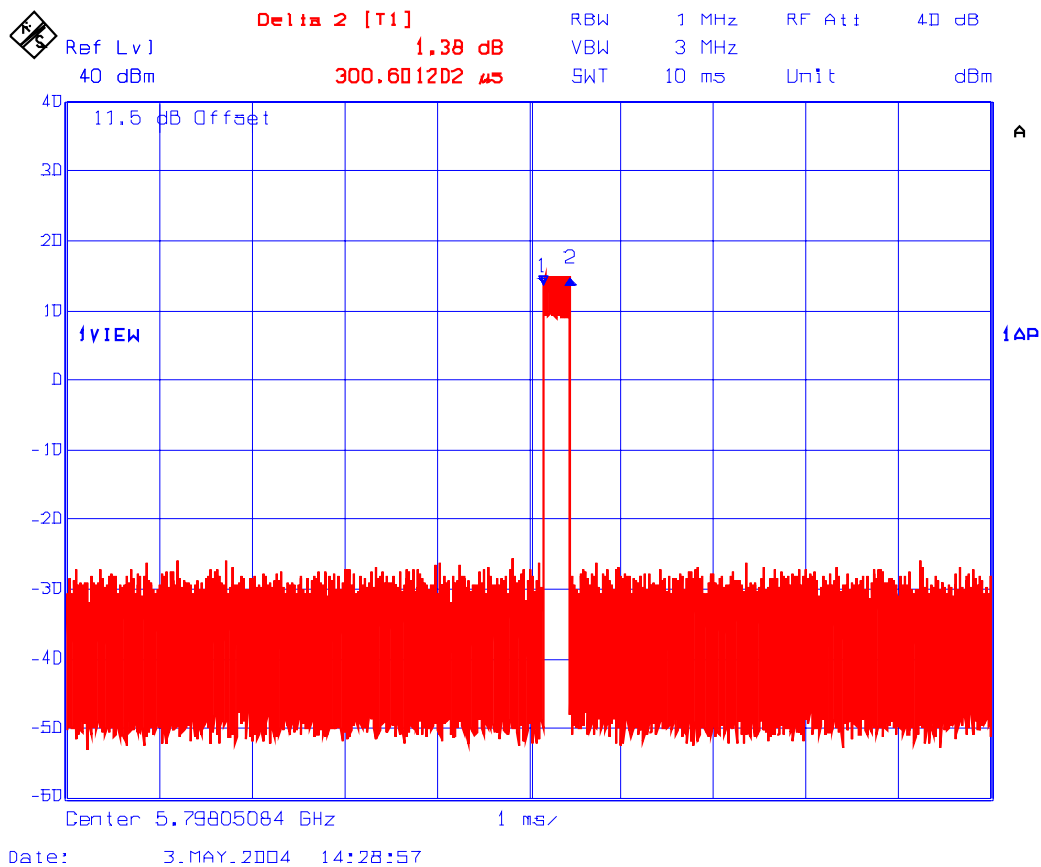

Dwell Time @ 5798.05084 MHz = 300.60 μsec

Plot 14:  
Time of Occupancy  
Test Frequency: 5798.05084 MHz (CH 43)

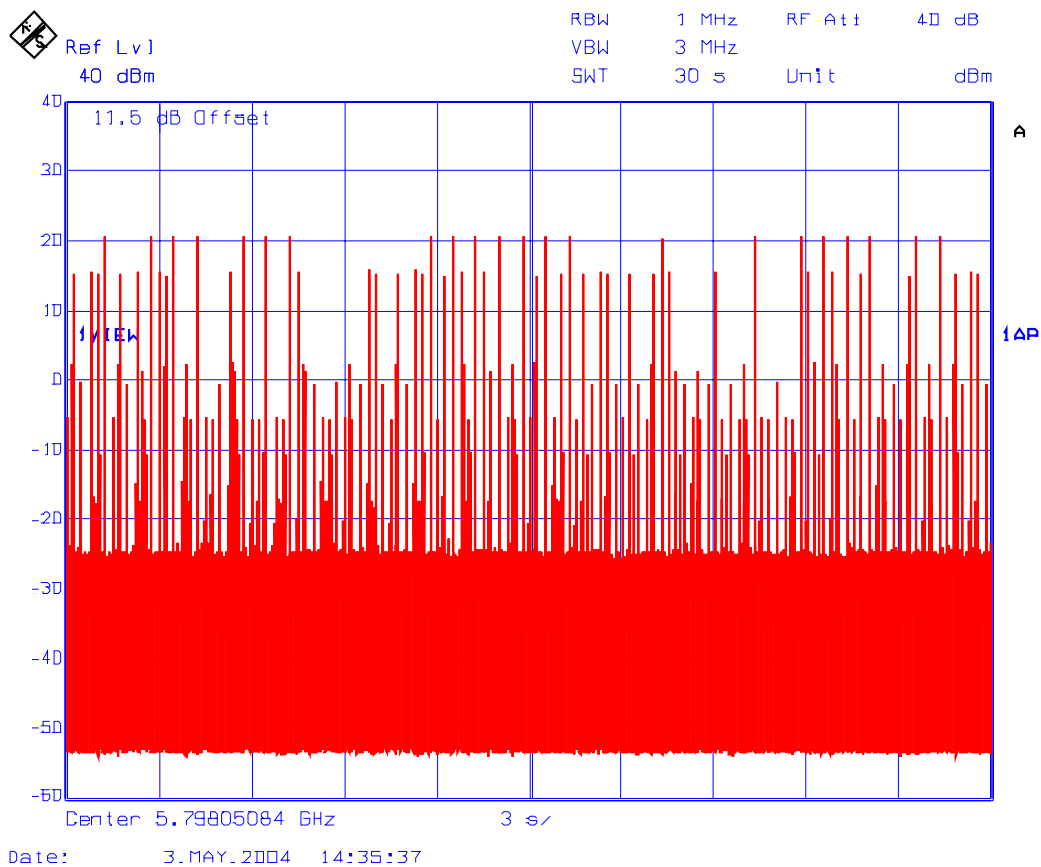

$$\begin{aligned} \text{Average time of occupancy in 30 s} &= (\text{Dwell Time @ 5798.05084 MHz}) \times (\text{number of hops in 30 s}) \\ &= 300.60 \mu\text{sec} \times 22 \\ &= 6.61 \text{ msec} \end{aligned}$$

Plot 15:  
Time of Occupancy  
Test Frequency: 5838.18697 MHz (CH 88)

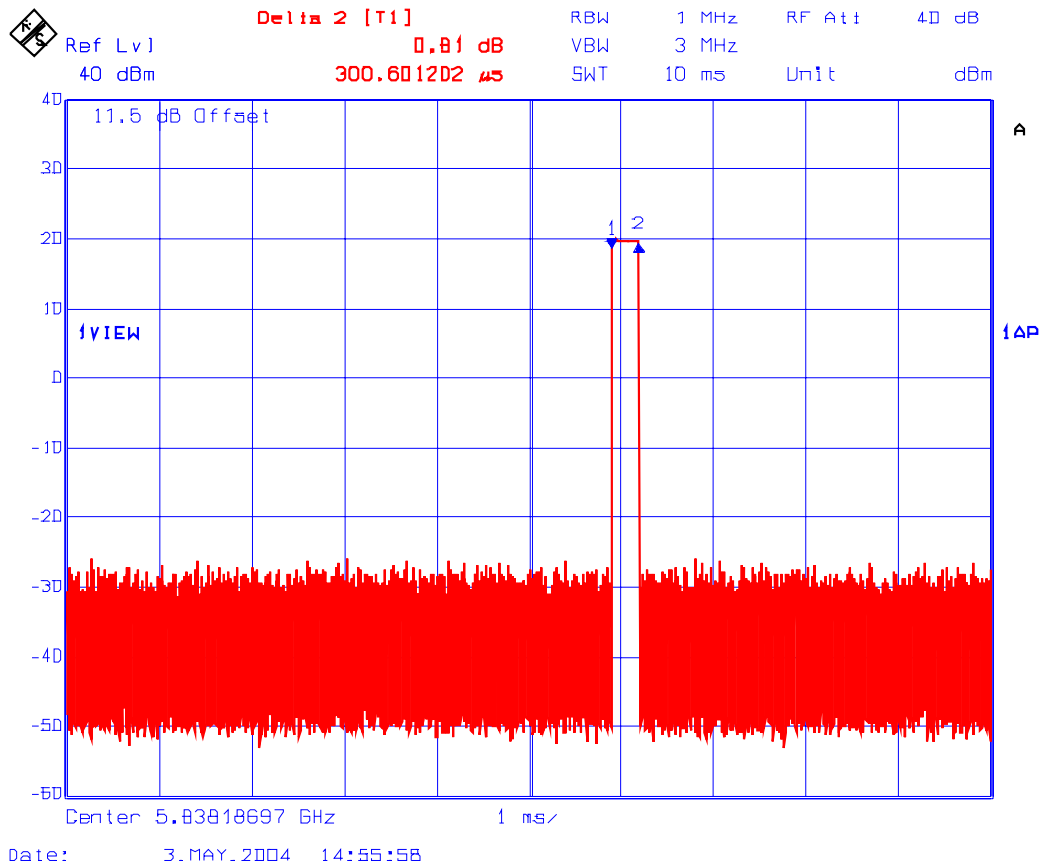

Dwell Time @ 5838.18697 MHz = 300.60 μsec

Plot 16:  
Time of Occupancy  
Test Frequency: 5838.18697 MHz (CH 88)

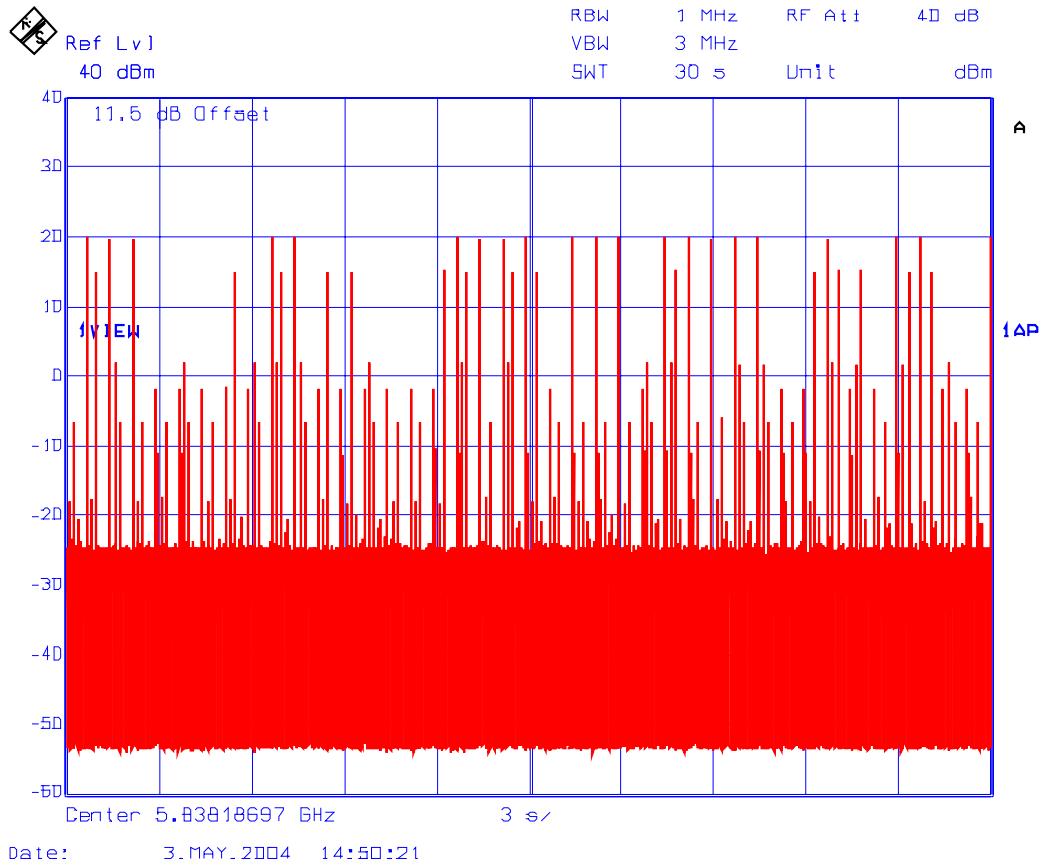

$$\begin{aligned} \text{Average time of occupancy in 30 s} &= (\text{Dwell Time @ 5838.18697 MHz}) \times (\text{number of hops in 30 s}) \\ &= 300.60 \mu\text{sec} \times 20 \\ &= 6.01 \text{ msec} \end{aligned}$$

FCC Specification	Manufacturer's Explanation
<b>FCC Requirement @ Section 15.247(a)(1):</b> The system shall hop to channel frequencies that are selected at the system hopping rate from a pseudo randomly ordered list of hopping frequencies. Each frequency must be used equally on the average by each transmitter. The system receivers shall have input bandwidths that match the hopping channel bandwidths of their corresponding transmitters and shall shift frequencies in synchronization with the transmitted signals	Refer to FHSS Descriptions
<b>FCC Requirement @ Section 15.247(g):</b> Describe how the EUT complies with the requirement that it be designed to be capable of operating as a true frequency hopping system	Refer to FHSS Descriptions
<b>FCC Requirement @ Section 15.247(h):</b> Describe how the EUT complies with the requirement that it does not have the ability to coordinated with other FHSS is an effort to avoid the simultaneous occupancy of individual hopping frequencies by multiple transmitters	Refer to FHSS Descriptions

## 5.8. PEAK OUTPUT POWER & EQUIVALENT ISOTROPIC RADIATED POWER (EIRP) [47 CFR § 15.247(b)]

### 5.8.1. Limits

The maximum peak output power of the intentional radiator shall not exceed the following:

- **§ 15.247(b)(1):** For frequency hopping systems in the 2400–2483.5 MHz band employing at least 75 hopping channels, and all frequency hopping systems in the 5725–5850 MHz band: 1 Watt. For all other frequency hopping systems in the 2400–2483.5 band: 0.125 Watt.
- **§ 15.247(b)(4):** If the antennas of directional gain greater than 6 dBi are used, the peak power from the intentional radiator shall be reduced below, as appropriate, by the amount in dB that the directional gain of the antenna exceeds 6 dBi.

### 5.8.2. Method of Measurements

Refer to Section 7.3 of this test report and ANSI C63-4

### 5.8.3. Test Arrangement

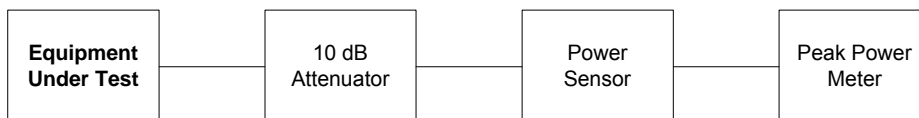

### 5.8.4. Test Equipment List

Test Instruments	Manufacturer	Model No.	Serial No.	Frequency Range
Peak Power Meter	Hewlett Packard	HP 8900D	3412A00103	9 kHz – 26.5 GHz
Power Sensor	Hewlett Packard	84811A	2551A02902	9 kHz – 26.5 GHz
Attenuator	Macom	3082-6193-10	--	--

### 5.8.5. Test Data

Transmitter Channel	Frequency (MHz)	Peak Power at Antenna Terminal (dBm)	*Calculated EIRP (dBm)	Conducted Power Limit (dBm)	EIRP Limit (dBm)
00	5759.70240	20.91	24.91	30.0	36.0
43	5798.05084	20.21	24.21	30.0	36.0
88	5838.18697	19.70	23.70	30.0	36.0

\* EIRP = Peak power at antenna terminal in dBm + EUT Antenna gain in dBi.

## 5.9. RF EXPOSURE REQUIRMENTS [47 CFR §§ 15.247(b)(5) & 1.1310]

### 5.9.1. Limits

- **FCC 15.247(b)(5):** Systems operating under provisions of this section shall be operated in a manner that ensures that the public is not exposed to radio frequency energy levels in excess of the Commission’s guidelines. See @ 1.1307(b)(1).
- **FCC 1.1310:-** The criteria listed in the following table shall be used to evaluate the environmental impact of human exposure to radio-frequency (RF) radiation as specified in 1.1307(b).

TABLE 1—LIMITS FOR MAXIMUM PERMISSIBLE EXPOSURE (MPE)

Frequency range (MHz)	Electric field strength (V/m)	Magnetic field strength (A/m)	Power density (mW/cm <sup>2</sup> )	Averaging time (minutes)
<b>(A) Limits for Occupational/Controlled Exposures</b>				
0.3–3.0 .....	614	1.63	*(100)	6
3.0–30 .....	1842/f	4.89/f	*(900/f <sup>2</sup> )	6
30–300 .....	61.4	0.163	1.0	6
300–1500 .....	.....	.....	f/300	6
1500–100,000 .....	.....	.....	5	6
<b>(B) Limits for General Population/Uncontrolled Exposure</b>				
0.3–1.34 .....	614	1.63	*(100)	30
1.34–30 .....	824/f	2.19/f	*(180/f <sup>2</sup> )	30
30–300 .....	27.5	0.073	0.2	30
300–1500 .....	.....	.....	f/1500	30
1500–100,000 .....	.....	.....	1.0	30

f = frequency in MHz

\* = Plane-wave equivalent power density

NOTE 1 TO TABLE 1: Occupational/controlled limits apply in situations in which persons are exposed as a consequence of their employment provided those persons are fully aware of the potential for exposure and can exercise control over their exposure. Limits for occupational/controlled exposure also apply in situations when an individual is transient through a location where occupational/controlled limits apply provided he or she is made aware of the potential for exposure.

NOTE 2 TO TABLE 1: General population/uncontrolled exposures apply in situations in which the general public may be exposed, or in which persons that are exposed as a consequence of their employment may not be fully aware of the potential for exposure or can not exercise control over their exposure.

### 5.9.2. Method of Measurements

Refer to FCC @ 1.1310, 2.1091 and Public Notice DA 00-705 (March 30, 2000)

- Spread spectrum transmitters operating under section 15.247 are categorically from routine environmental evaluation to demonstrating RF exposure compliance with respect to MPE and/or SAR limits. These devices are not exempted from compliance (As indicated in Section 15.247(b)(4), these transmitters are required to operate in a manner that ensures that exposure to public users and nearby persons) does not exceed the Commission’s RF exposure guidelines (see Section 1.1307 and 2.1093). Unless a device operates at substantially low power levels, with a low gain antenna(s), supporting information is generally needed to establish the various potential operating configurations and exposure conditions of a transmitter and its antenna(s) in order to determine compliance with the RF exposure guidelines.

- In order to demonstrate compliance with MPE requirements (see Section 2.1091), the following information is typically needed:
  - (1) Calculation that estimates the minimum separation distance (20 cm or more) between an antenna and persons required to satisfy power density limits defined for free space.
  - (2) Antenna installation and device operating instructions for installers (professional/unskilled users), and the parties responsible for ensuring compliance with the RF exposure requirement
  - (3) Any caution statements and/or warning labels that are necessary in order to comply with the exposure limits
  - (4) Any other RF exposure related issues that may affect MPE compliance

**Calculation Method of RF Safety Distance:**

$$S = PG/4\pi r^2 = EIRP/4\pi r^2$$

Where: P: power input to the antenna in mW  
EIRP: Equivalent (effective) isotropic radiated power  
S: power density mW/cm<sup>2</sup>  
G: numeric gain of antenna relative to isotropic radiator  
r: distance to centre of radiation in cm

$$r = \sqrt{PG/4\pi S}$$

- For portable transmitters (see Section 2.1093), or devices designed to operate next to a person's body, compliance is determined with respect to the SAR limit (define in the body tissues) for near-field exposure conditions. If the maximum average output power, operating condition configurations and exposure conditions are comparable to those of existing cellular and PCS phones., an SAR evaluation may be required in order to determine if such a device complies with SAR limit. When SAR evaluation data is not available, and the additional supporting information cannot assure compliance, the Commission may request that an SAR evaluation be performed, as provided for in Section 1.1307(d)

**5.9.3. MPE Evaluation**

<b>Evaluation of RF Exposure Compliance Requirements</b>	
<b>RF Exposure Requirements</b>	<b>Compliance with FCC Rules</b>
Minimum calculated separation distance between antenna and persons required: <b>*5.0 cm</b>	Manufacturer' instruction for separation distance between antenna and persons required: <b>20 cm.</b>
Antenna installation and device operating instructions for installers (professional/unskilled users), and the parties responsible for ensuring compliance with the RF exposure requirement	None, antenna is permanently attached.
Caution statements and/or warning labels that are necessary in order to comply with the exposure limits	Please refer to User's Manual for RF Exposure Information.
Any other RF exposure related issues that may affect MPE compliance	None.

\* The minimum separation distance between the antenna and bodies of users are calculated using the following formula:

$$\text{RF EXPOSURE DISTANCE LIMITS: } r = (PG/4\pi S)^{1/2} = (\text{EIRP}/4\pi S)^{1/2}$$

$$S = 1.0 \text{ mW/cm}^2$$

$$\text{EIRP} = 24.91 \text{ dBm} = 309.74 \text{ mW (Max. EIRP)}$$

$$r = (\text{EIRP}/4\pi S)^{1/2} = (309.74 / 4\pi(1.0))^{1/2} = 5.0 \text{ cm}$$

## 5.10. TRANSMITTER BAND-EDGE & SPURIOUS CONDUCTED EMISSIONS [47 CFR § 15.247(c)]

### 5.10.1. Limits

In any 100 KHz bandwidth outside the operating frequency band, in which the spread spectrum or digitally modulated intentional radiator is operating, the radio frequency power that is produced by the intentional radiator shall be at least 20 dB below that in the 100 KHz bandwidth within the band that contains the highest level of the desired power, based on either an RF conducted or a radiated measurement.

### 5.10.2. Method of Measurements

Refer to Section 7.4 of this test report and ANSI C63-4

### 5.10.3. Test Arrangement

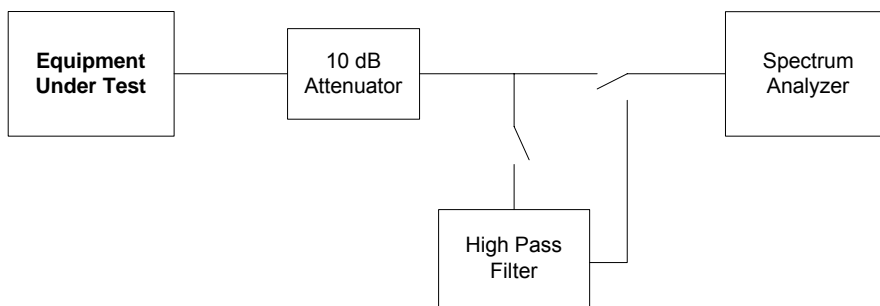

### 5.10.4. Test Equipment List

Test Instruments	Manufacturer	Model No.	Serial No.	Frequency Range
Spectrum Analyzer	Rohde & Schwarz	FSEK20/B4/B21	834157/005	9 kHz – 40 GHz
Attenuator	Macom	3082-6193-10	--	--
High Pass Filter	K & L	11SH10-8000/T18000-0/0	3	Cut-off Frequency at 8 GHz

### 5.10.5. Test Data

#### 5.10.5.1. Band-Edge RF Conducted Emissions

Refer to the following test data plots (17 to 20) for measurement results:

Plot 17:  
Band-Edge RF Conducted Emissions  
Low End of Frequency Band  
Single Frequency Mode

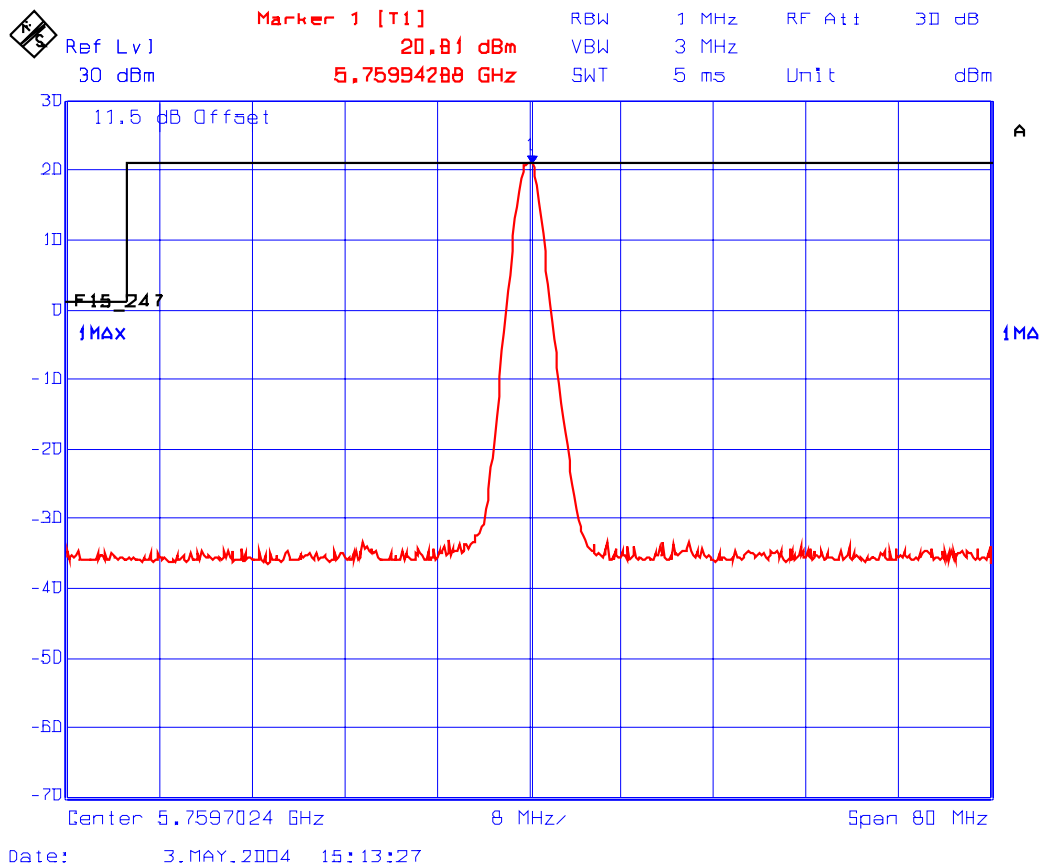

Plot 18:  
Band-Edge RF Conducted Emissions  
Low End of Frequency Band  
Pseudorandom Channel Hopping Mode

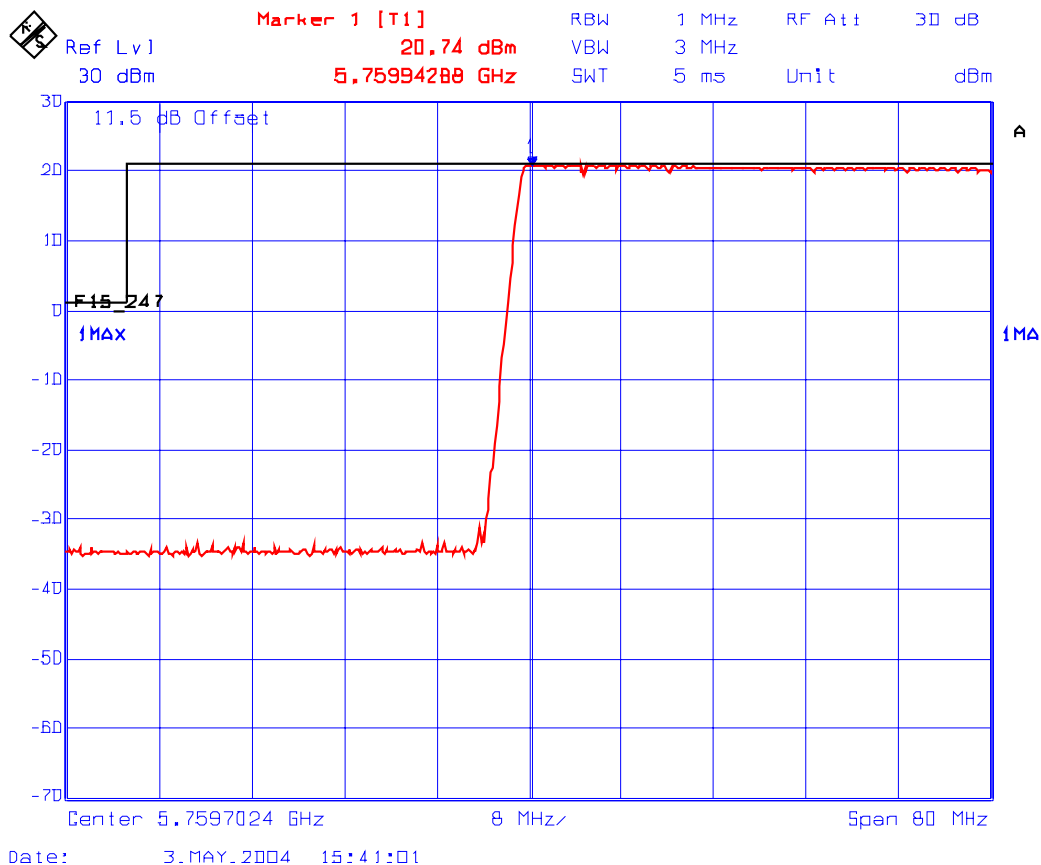

**ULTRATECH GROUP OF LABS**

3000 Bristol Circle, Oakville, Ontario, Canada L6H 6G4  
Tel. #: 905-829-1570, Fax. #: 905-829-8050, Email: [vic@ultratech-labs.com](mailto:vic@ultratech-labs.com), Website: <http://www.ultratech-labs.com>

File #: PAN-051F15C247  
May 10, 2004

All test results contained in this engineering test report are traceable to National Institute of Standards and Technology (NIST)

Plot 19:  
Band-Edge RF Conducted Emissions  
High End of Frequency Band  
Single Frequency Mode

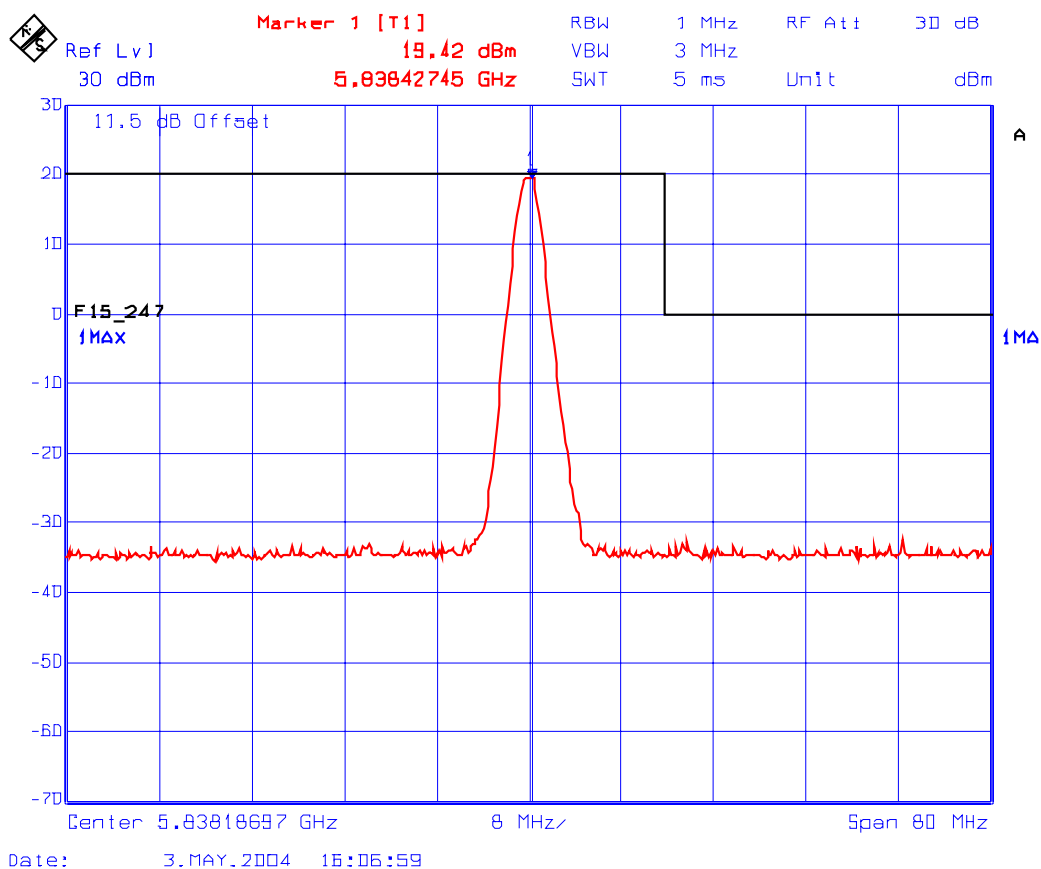

Plot 20:  
Band-Edge RF Conducted Emissions  
High End of Frequency Band  
Pseudorandom Channel Hopping Mode

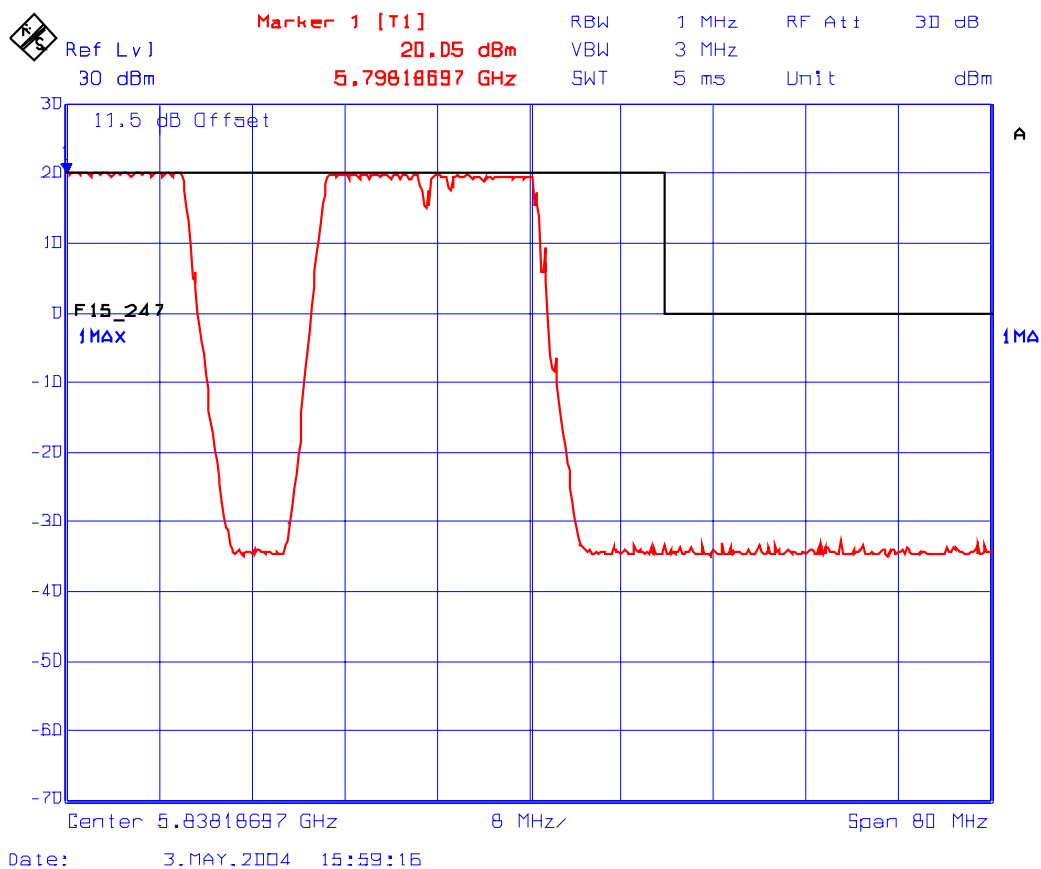

**ULTRATECH GROUP OF LABS**

3000 Bristol Circle, Oakville, Ontario, Canada L6H 6G4  
Tel. #: 905-829-1570, Fax. #: 905-829-8050, Email: [vic@ultratech-labs.com](mailto:vic@ultratech-labs.com), Website: <http://www.ultratech-labs.com>

File #: PAN-051F15C247  
May 10, 2004

All test results contained in this engineering test report are traceable to National Institute of Standards and Technology (NIST)

5.10.5.2. Transmitter Spurious RF Conducted Emissions

5.10.5.2.1. Lowest Frequency (5759.70240 MHz)

The emissions were scanned from 10 MHz to 40 GHz; refer to the following test data plots (21 to 22) for measurement results.

Plot 21:  
Spurious RF Conducted Emissions  
Transmitter Frequency: 5759.70240 MHz (CH 00)

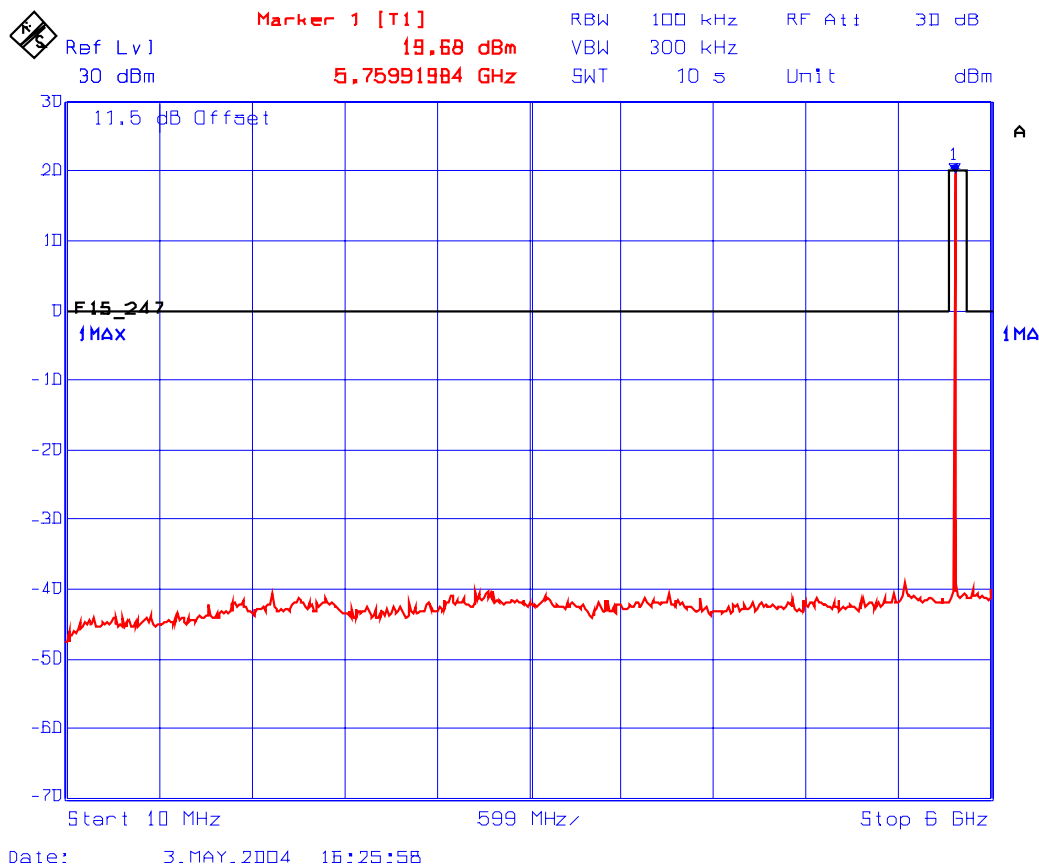

Plot 22:  
 Spurious RF Conducted Emissions  
 Transmitter Frequency: 5759.70240 MHz (CH 00)

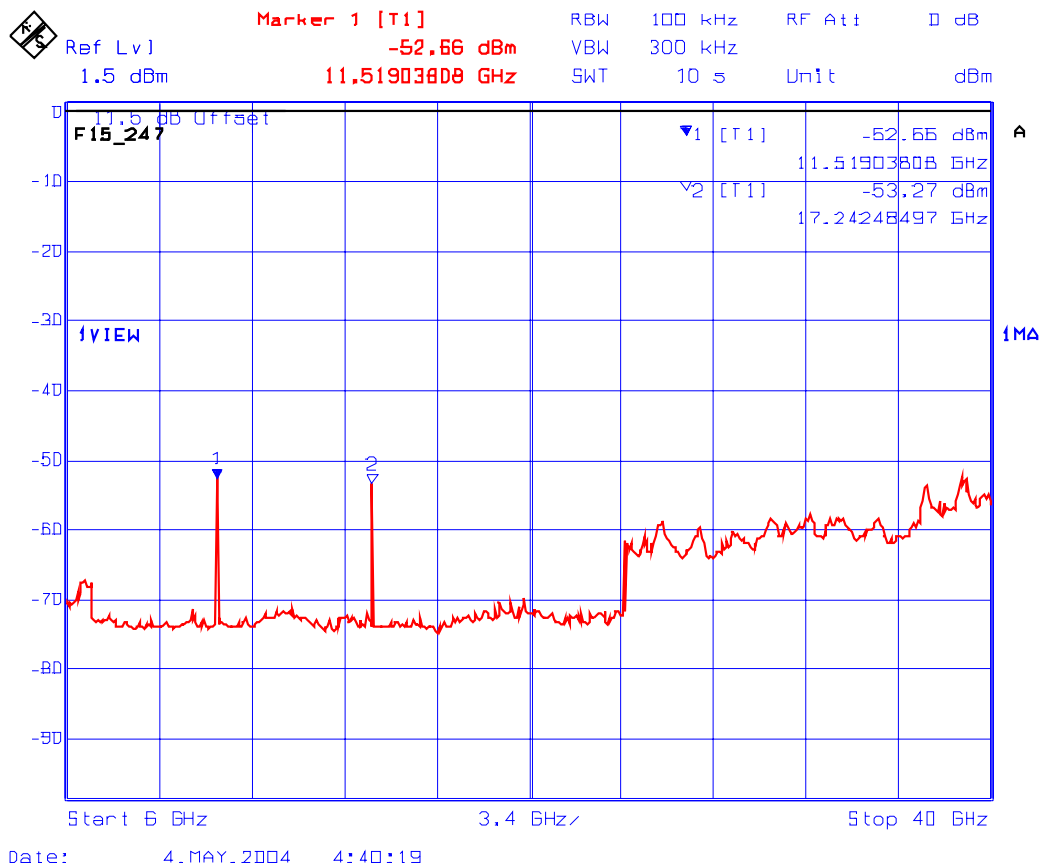

5.10.5.2.2. Middle Frequency (5798.05084 MHz)

The emissions were scanned from 10 MHz to 40 GHz; refer to the following test data plots (23 to 24) for measurement results.

Plot 23:  
Spurious RF Conducted Emissions  
Transmitter Frequency: 5798.05084 MHz (CH 43)

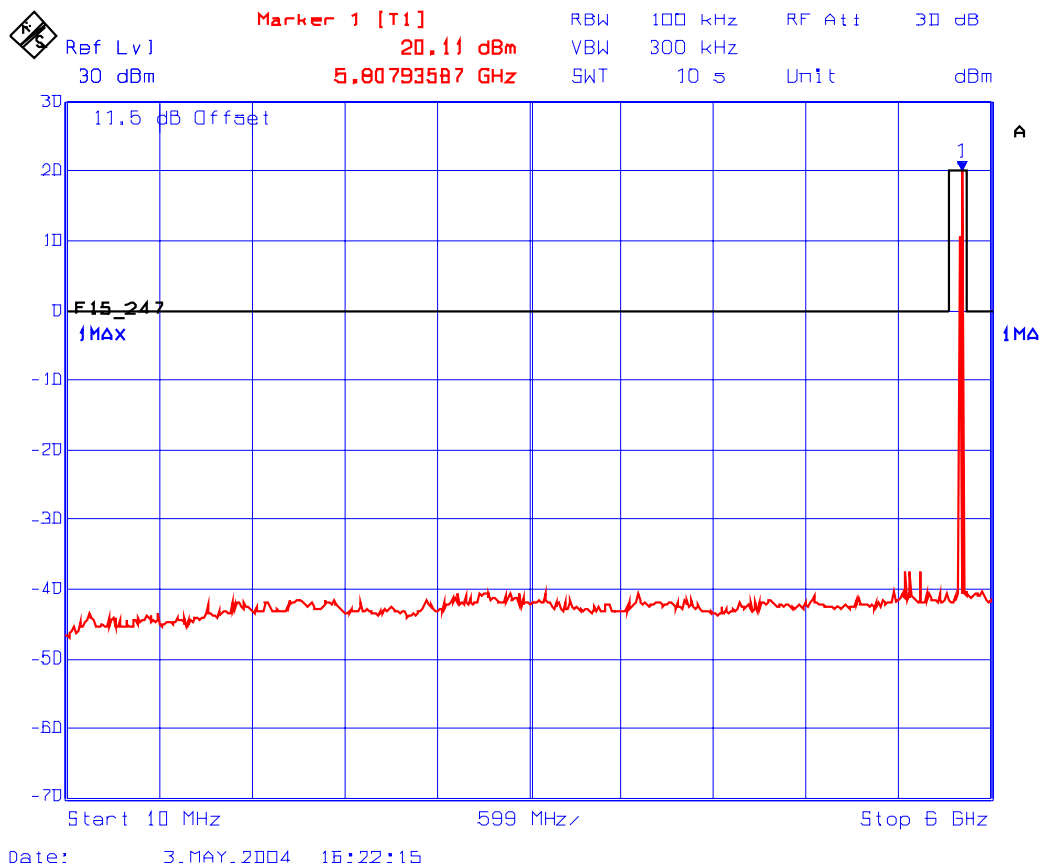

Plot 24:  
 Spurious RF Conducted Emissions  
 Transmitter Frequency: 5798.05084 MHz (CH 43)

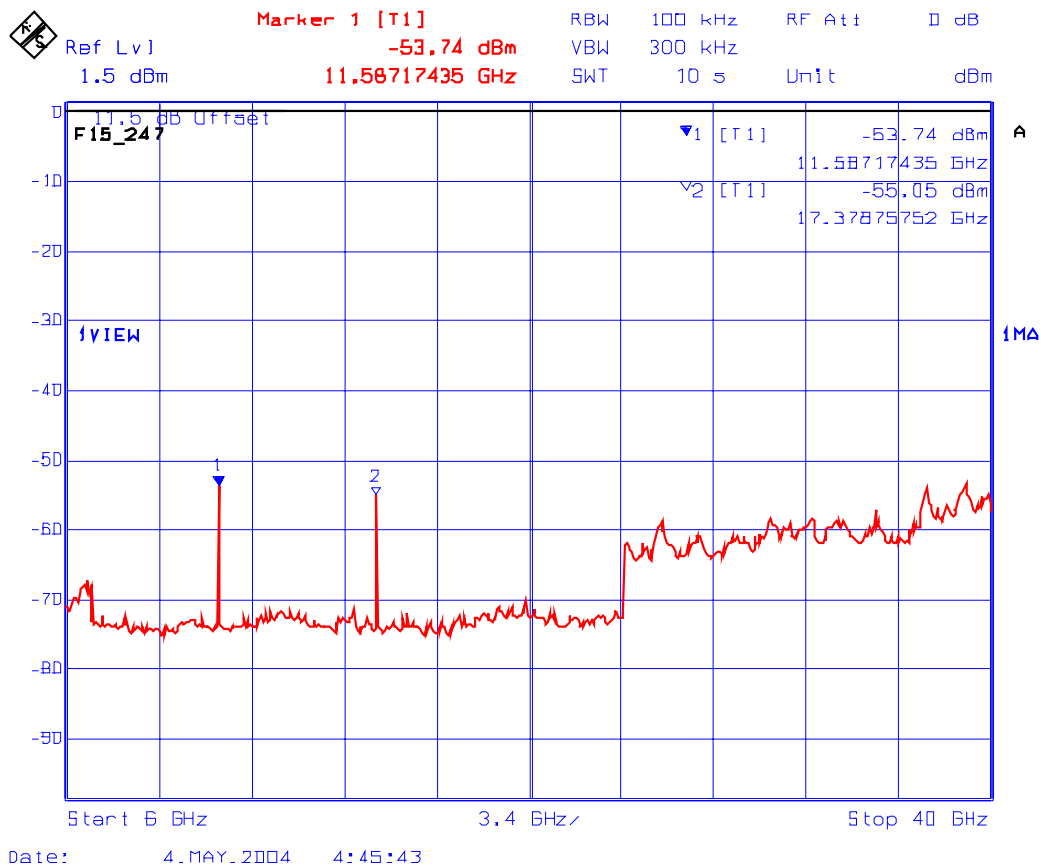

5.10.5.2.3. Highest Frequency (5838.18697 MHz)

The emissions were scanned from 10 MHz to 40 GHz; refer to the following test data plots (25 to 26) for measurement results.

Plot 25:  
Spurious RF Conducted Emissions  
Transmitter Frequency: 5838.18697 MHz (CH 88)

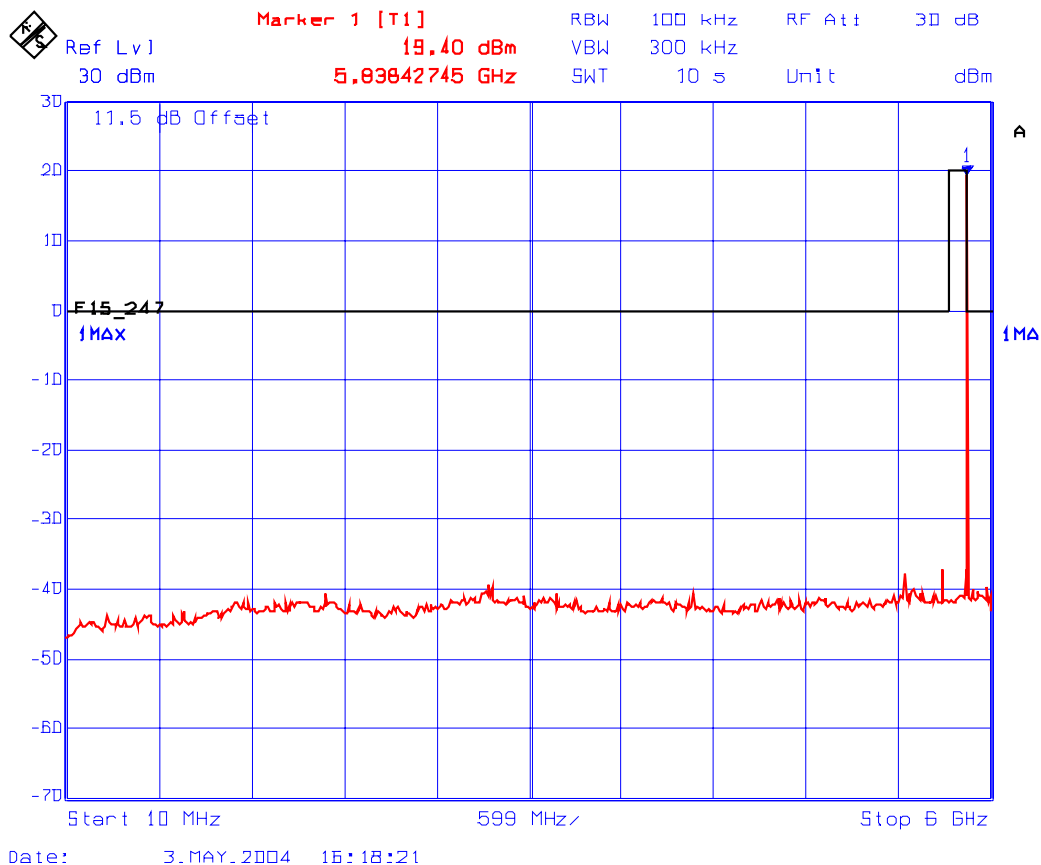

Plot 26:  
 Spurious RF Conducted Emissions  
 Transmitter Frequency: 5838.18697 MHz (CH 88)

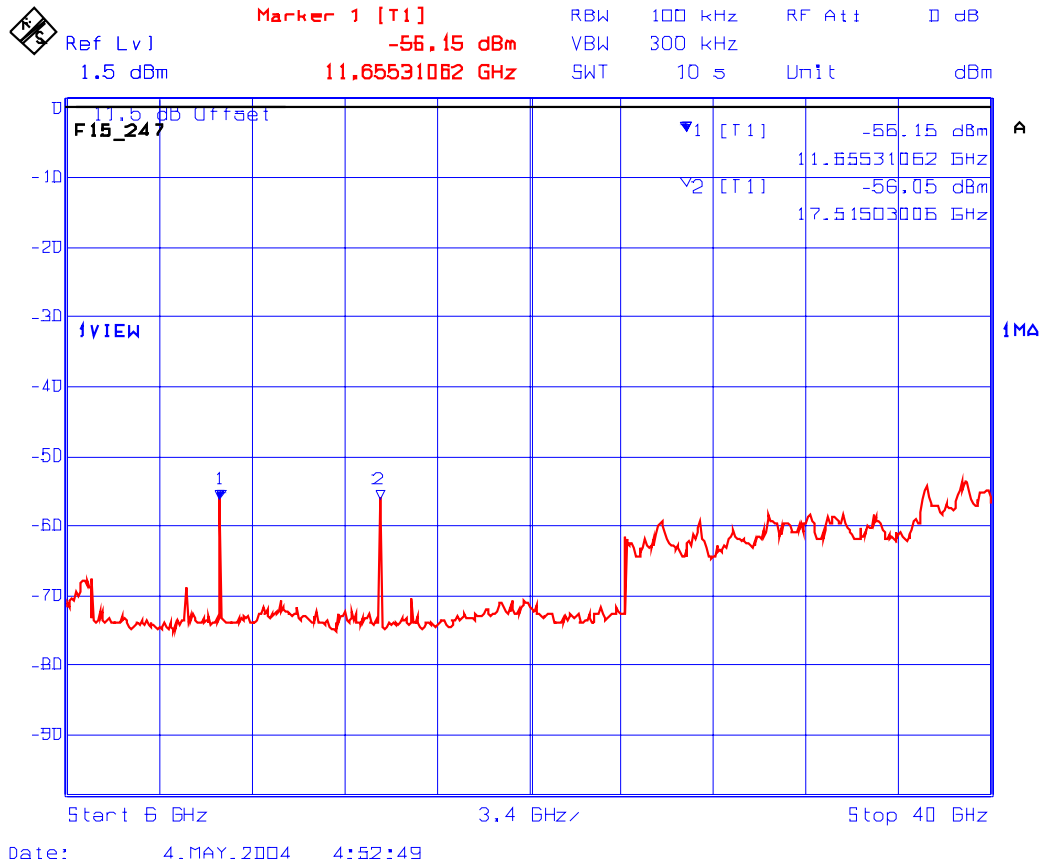

## 5.11. TRANSMITTER BAND-EDGE & SPURIOUS RADIATED EMISSIONS AT 3 METERS [47 CFR §§ 15.247(c), 15.209 & 15.205]

### 5.11.1. Limits

In any 100 KHz bandwidth outside the operating frequency band, in which the spread spectrum or digitally modulated intentional radiator is operating, the radio frequency power that is produced by the intentional radiator shall be at least 20 dB below that in the 100 KHz bandwidth within the band that contains the highest level of the desired power, based on either an RF conducted or a radiated measurement. Attenuation below the general limits specified in Section 15.209(a) is not required.

In addition, radiated emissions, which fall in the restricted bands, as defined in Section 15.205(a), must also comply with the radiated emission limits specified in section 15.209(a) (see Section 15.205(c)).

#### Remarks:

- Applies to harmonics/spurious emissions that fall in the restricted bands listed in section 15.205. The maximum permitted average field strength is listed in section 15.209.
- The emission limits as specified above are based on measurement instrument employing an average detector. The provisions in section 15.35 for limiting peak emissions apply.

#### 47 CFR 15.205(a) - Restricted Frequency Bands

MHz	MHz	MHz	GHz
0.090-0.110	16.42-16.423	399.9-410	4.5-5.15
1 0.495-0.505	16.69475-16.69525	608-614	5.35-5.46
2.1735-2.1905	16.80425-16.80475	960-1240	7.25-7.75
4.125-4.128	25.5-25.67	1300-1427	8.025-8.5
4.17725-4.17775	37.5-38.25	1435-1626.5	9.0-9.2
4.20725-4.20775	73-74.6	1645.5-1646.5	9.3-9.5
6.215-6.218	74.8-75.2	1660-1710	10.6-12.7
6.26775-6.26825	108-121.94	1718.8-1722.2	13.25-13.4
6.31175-6.31225	123-138	2200-2300	14.47-14.5
8.291-8.294	149.9-150.05	2310-2390	15.35-16.2
8.362-8.366	156.52475-156.52525	2483.5-2500	17.7-21.4
8.37625-8.38675	156.7-156.9	2655-2900	22.01-23.12
8.41425-8.41475	162.0125-167.17	3260-3267	23.6-24.0
12.29-12.293	167.72-173.2	3332-3339	31.2-31.8
12.51975-12.52025	240-285	3345.8-3358	36.43-36.5
12.57675-12.57725	322-335.4	3600-4400	( <sup>2</sup> )
13.36-13.41			

<sup>1</sup> Until February 1, 1999, this restricted band shall be 0.490-0.510 MHz.  
<sup>2</sup> Above 38.6

#### 47 CFR 15.209(a) -- Field Strength Limits within Restricted Frequency Bands --

Frequency (MHz)	Field Strength (microvolts/meter)	Measurement Distance (meters)
0.009 - 0.490	2,400 / F (kHz)	300
0.490 - 1.705	24,000 / F (kHz)	30
1.705 - 30.0	30	30
30 - 88	100	3
88 - 216	150	3
216 - 960	200	3
Above 960	500	3

**5.11.2. Method of Measurements**

Refer to Section 7.4 of this test report and ANSI C63.4 for detailed radiated emissions measurement procedures.

The following measurement procedures were also applied:

- Applies to harmonics/spurious that fall in the restricted bands listed in Section 15.205. the maximum permitted average field strength is listed in Section 15.209. A Pre-Amp and highpass filter are used for this measurement.
- For measurement below 1 GHz, set RBW = 100 KHz, VBW ≥ 100 KHz, SWEEP=AUTO.
- For measurement above 1 GHz, set RBW = 1 MHz, VBW = 1 MHz (Peak) & VBW = 10 Hz (Average), SWEEP=AUTO.
- If the emission is pulsed, modified the unit for continuous operation, then use the settings above for measurements, then correct the reading by subtracting the peak-average correction factor derived from the appropriate duty cycle calculation. See Sections 15.35(b) and (c).

**5.11.3. Test Arrangement**

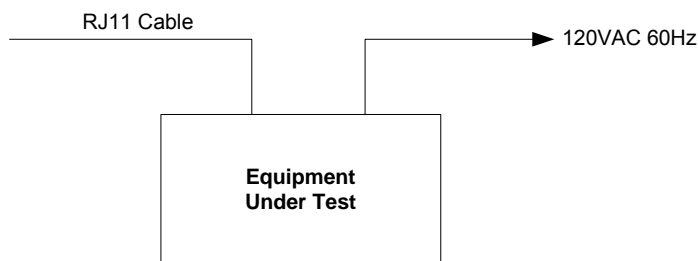

**5.11.4. Test Equipment List**

Test Instruments	Manufacturer	Model No.	Serial No.	Frequency Range
Spectrum Analyzer	Rohde & Schwarz	FSEK20/B4/B21	834157/005	9 kHz – 40 GHz
Microwave Amplifier	Hewlett Packard	83051A	3611A01947	40 MHz to 50 GHz
Biconilog Antenna	EMCO	3143	1029	20 MHz to 2 GHz
Horn Antenna	EMCO	3155	9701-5061	1 GHz – 18 GHz
Horn Antenna	EMCO	3160-09	..	18 GHz – 26.5 GHz
Horn Antenna	EMCO	3160-10	..	26.5 GHz – 40 GHz
Mixer	Tektronix	118-0098-00	..	18 GHz – 26.5 GHz
Mixer	Tektronix	119-0098-00	..	26.5 GHz – 40 GHz

**5.11.5. Test Data**

The following test results are the worst-case measurements:

**5.11.5.1. Band-Edge RF Radiated Emissions @ 3 Meters**

Refer to the following test data plots (27 to 30) for measurement results:

Plot 27:  
 Band-Edge RF Radiated Emissions @ 3 meters  
 Low End of Frequency Band  
 Vertical Polarization

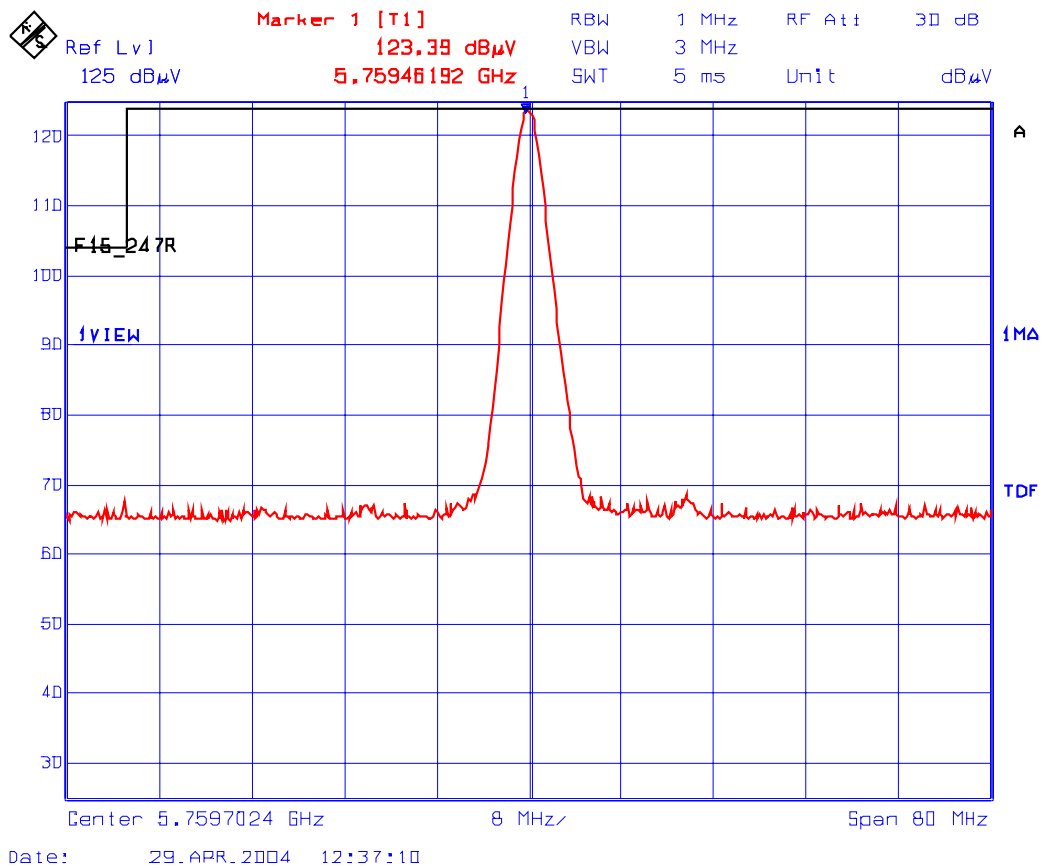

Plot 28:  
Band-Edge RF Radiated Emissions @ 3 meters  
Low End of Frequency Band  
Horizontal Polarization

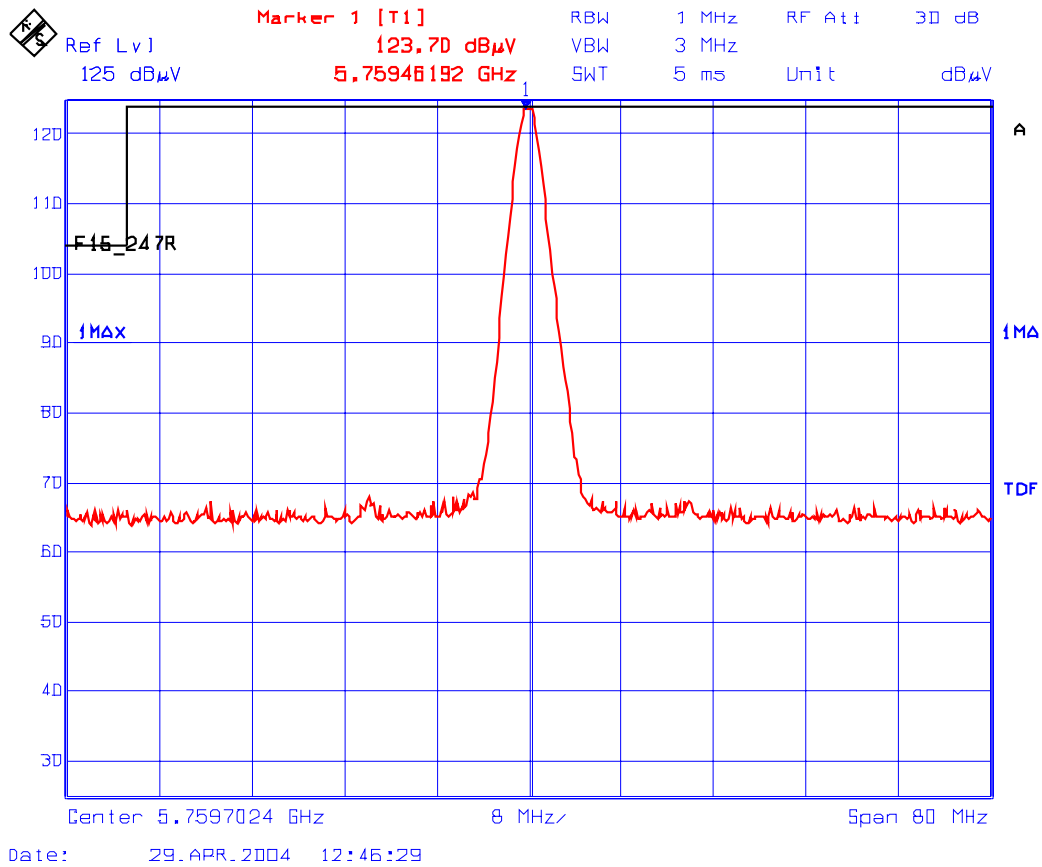

**ULTRATECH GROUP OF LABS**

3000 Bristol Circle, Oakville, Ontario, Canada L6H 6G4  
Tel. #: 905-829-1570, Fax. #: 905-829-8050, Email: [vic@ultratech-labs.com](mailto:vic@ultratech-labs.com), Website: <http://www.ultratech-labs.com>

File #: PAN-051F15C247

May 10, 2004

All test results contained in this engineering test report are traceable to National Institute of Standards and Technology (NIST)

Plot 29:  
Band-Edge RF Radiated Emissions @ 3 meters  
Upper End of Frequency Band  
Vertical Polarization

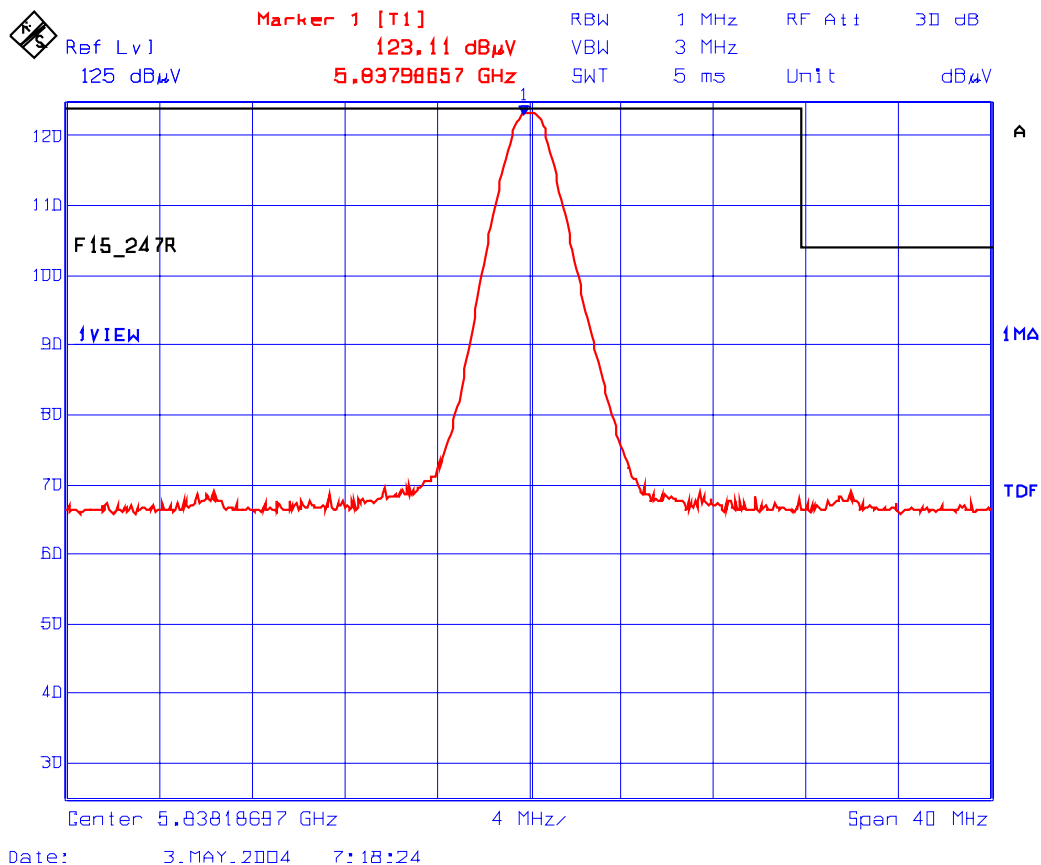

Plot 30:  
Band-Edge RF Radiated Emissions @ 3 meters  
Upper End of Frequency Band  
Horizontal Polarization

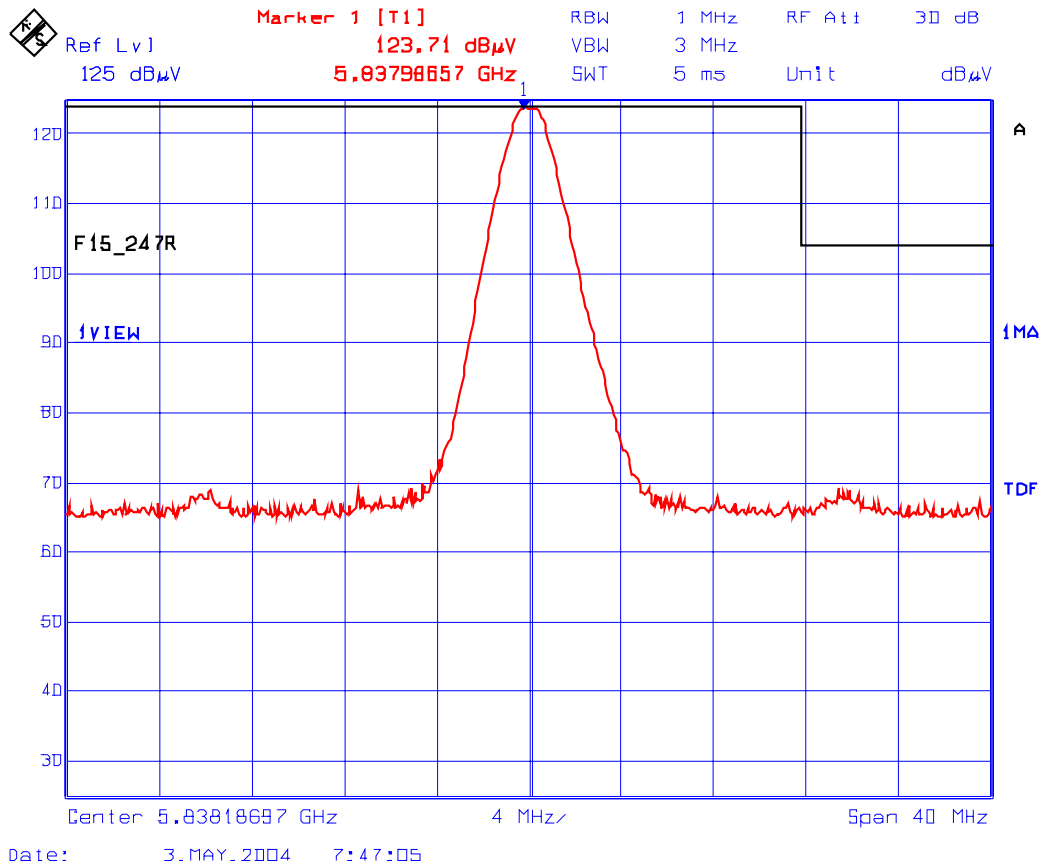

**5.11.5.2. Spurious Radiated Emissions @ 3 Meters**

Fundamental Frequency: 5759.70240 MHz (CH 00)  
 Frequency Test Range: 30 MHz – 40 GHz

Frequency (MHz)	RF Peak Level (dBµV/m)	RF Avg Level (dBµV/m)	Antenna Plane (H/V)	Limit 15.209 (dBµV/m)	Limit 15.247 (dBµV/m)	Margin (dB)	Pass/Fail
5759.7024	123.39	--	V	--	--	--	--
5759.7024	123.70	--	H	--	--	--	--
11519.4048	58.69	43.10	V	54.0	103.7	-10.9	Pass*
11519.4048	59.34	42.76	H	54.0	103.7	-11.2	Pass*

All other spurious emissions and harmonics are more than 20 dB below the permissible limit.

\* Emission inside restricted bands.

Fundamental Frequency: 5798.05804 MHz (CH 43)  
 Frequency Test Range: 30 MHz – 40 GHz

Frequency (MHz)	RF Peak Level (dBµV/m)	RF Avg Level (dBµV/m)	Antenna Plane (H/V)	Limit 15.209 (dBµV/m)	Limit 15.247 (dBµV/m)	Margin (dB)	Pass/Fail
5798.0508	123.35	--	V	--	--	--	--
5798.0508	123.86	--	H	--	--	--	--
11596.1016	56.94	43.36	V	54.0	103.9	-10.6	Pass*
11596.1016	59.41	43.28	H	54.0	103.9	-10.7	Pass*

All other spurious emissions and harmonics are more than 20 dB below the permissible limit.

\* Emission inside restricted bands.

Fundamental Frequency: 5838.18697 MHz (CH 88)  
 Frequency Test Range: 30 MHz – 40 GHz

Frequency (MHz)	RF Peak Level (dBµV/m)	RF Avg Level (dBµV/m)	Antenna Plane (H/V)	Limit 15.209 (dBµV/m)	Limit 15.247 (dBµV/m)	Margin (dB)	Pass/Fail
5838.1870	123.11	--	V	--	--	--	--
5838.1870	123.81	--	H	--	--	--	--
11676.3740	58.17	42.62	V	54.0	103.8	-11.4	Pass*
11676.3740	58.24	43.07	H	54.0	103.8	-10.9	Pass*

All other spurious emissions and harmonics are more than 20 dB below the permissible limit.

\* Emission inside restricted bands.

## EXHIBIT 6. MEASUREMENT UNCERTAINTY

The measurement uncertainties stated were calculated in accordance with the requirements of NIST Technical Note 1297 and NIS 81 (1994)

### 6.1. LINE CONDUCTED EMISSION MEASUREMENT UNCERTAINTY

CONTRIBUTION (Line Conducted)	PROBABILITY DISTRIBUTION	UNCERTAINTY (dB)	
		9-150 kHz	0.15-30 MHz
EMI Receiver specification	Rectangular	$\pm 1.5$	$\pm 1.5$
LISN coupling specification	Rectangular	$\pm 1.5$	$\pm 1.5$
Cable and Input Transient Limiter calibration	Normal (k=2)	$\pm 0.3$	$\pm 0.5$
Mismatch: Receiver VRC $\Gamma_1 = 0.03$ LISN VRC $\Gamma_R = 0.8(9 \text{ kHz}) 0.2 (30 \text{ MHz})$ Uncertainty limits $20\text{Log}(1 \pm \Gamma_1 \Gamma_R)$	U-Shaped	$\pm 0.2$	$\pm 0.3$
System repeatability	Std. deviation	$\pm 0.2$	$\pm 0.05$
Repeatability of EUT	--	--	--
Combined standard uncertainty	Normal	$\pm 1.25$	$\pm 1.30$
Expanded uncertainty U	Normal (k=2)	$\pm 2.50$	$\pm 2.60$

Sample Calculation for Measurement Accuracy in 450 kHz to 30 MHz Band:

$$u_c(y) = \sqrt{\sum_{i=1}^m u_i^2(y)} = \pm \sqrt{(1.5^2 + 1.5^2)/3 + (0.5/2)^2 + (0.05/2)^2 + 0.35^2} = \pm 1.30 \text{ dB}$$

$$U = 2u_c(y) = \pm 2.6 \text{ dB}$$

## 6.2. RADIATED EMISSION MEASUREMENT UNCERTAINTY

CONTRIBUTION (Radiated Emissions)	PROBABILITY DISTRIBUTION	UNCERTAINTY ( $\pm$ dB)	
		3 m	10 m
Antenna Factor Calibration	Normal (k=2)	$\pm 1.0$	$\pm 1.0$
Cable Loss Calibration	Normal (k=2)	$\pm 0.3$	$\pm 0.5$
EMI Receiver specification	Rectangular	$\pm 1.5$	$\pm 1.5$
Antenna Directivity	Rectangular	+0.5	+0.5
Antenna factor variation with height	Rectangular	$\pm 2.0$	$\pm 0.5$
Antenna phase center variation	Rectangular	0.0	$\pm 0.2$
Antenna factor frequency interpolation	Rectangular	$\pm 0.25$	$\pm 0.25$
Measurement distance variation	Rectangular	$\pm 0.6$	$\pm 0.4$
Site imperfections	Rectangular	$\pm 2.0$	$\pm 2.0$
Mismatch: Receiver VRC $\Gamma_1 = 0.2$ Antenna VRC $\Gamma_R = 0.67$ (Bi) 0.3 (Lp) Uncertainty limits $20\text{Log}(1+\Gamma_1\Gamma_R)$	U-Shaped	+1.1 -1.25	$\pm 0.5$
System repeatability	Std. Deviation	$\pm 0.5$	$\pm 0.5$
Repeatability of EUT		-	-
Combined standard uncertainty	Normal	+2.19 / -2.21	+1.74 / -1.72
Expanded uncertainty U	Normal (k=2)	+4.38 / -4.42	+3.48 / -3.44

Calculation for maximum uncertainty when 3m biconical antenna including a factor of k = 2 is used:

$$U = 2u_c(y) = 2x(+2.19) = +4.38 \text{ dB} \quad \text{And} \quad U = 2u_c(y) = 2x(-2.21) = -4.42 \text{ dB}$$

## EXHIBIT 7. MEASUREMENT METHODS

### 7.1. GENERAL TEST CONDITIONS

The following test conditions shall be applied throughout the tests covered in this report.

#### 7.1.1. Normal temperature and humidity

- Normal temperature: +15°C to +35°C
- Relative Humidity: +20% to 75%

The actual values during tests shall be recorded in the test report.

#### 7.1.2. Normal power source

##### 7.1.2.1. Mains Voltage

The nominal test voltage of the equipment to be connected to mains shall be the nominal mains voltage which is the declared voltage or any of the declared voltages for which the equipment was designed.

The frequency of test power source corresponding to the AC mains shall be between 59 Hz and 61 Hz.

##### 7.1.2.2. Battery Power Source.

For operation from battery power sources, the nominal test voltage shall be as declared by the equipment manufacturer. This shall be recorded in the test report.

#### 7.1.3. Operating Condition of Equipment under Test

- All tests shall be performed with the device operating at the number of frequencies in each band specified in the following table:

Frequency range over which device operates	Number of frequencies	Location in the range of operation
1 MHz or less	1	Middle.
1 to 10 MHz	2	1 near top and 1 near bottom.
More than 10 MHz	3	1 near top, 1 near middle and 1 near bottom.

- Modulation were applied using the Test Data sequence
- The transmitter was operated at the highest output power, or in the case the equipment able to operate at more than one power level, at the lowest and highest output powers

## 7.2. METHOD OF MEASUREMENTS - AC MAINS CONDUCTED EMISSIONS

- AC Mains conducted emissions measurements were performed in accordance with the standard against appropriate limits for each detector function.
- The test was performed in the shielded room, 24'(L) x 16'(W) x 8'(H).
- The test was performed were made over the frequency range from 150 kHz to 30 MHz to determine the line-to-ground radio noise voltage which was conducted from the EUT power-input terminals that were directly connected to a public power network.
- The EUT normally received power from another device that connects to the public utility ac power lines, measurements would be made on that device with the EUT in operation to ensure that the device continues to comply with the appropriate limits while providing the EUT with power.
- If the EUT operates only from internal or dedicated batteries, with no provisions for connection to the public utility ac power lines, AC Mains conducted measurements are not required.
- Table-top devices were placed on a platform of nominal size 1 m by 1.5m raised 80 cm above the conducting ground plane.
- The EUT current-carrying power lead, except the ground (safety) lead, was individually connected through a LISN to the power source. All unused 50-Ohm connectors of the LISN was terminated in 50-ohm when not connected to the measuring instruments.
- The line cord of the EUT connected to one LISN which was connected to the measuring instrument. Those power cords for the units of devices not under measurement were connected to a separate multiple ac outlet. Drawings and photographs of typically conducted emission test setups were shown in the Test Report. Each current-carrying conductor of the EUT shall be individually tested.
- The EUT was normally operated with a ground (safety) connection, the EUT was connected to the ground at the LISN through a conductor provided in the lead from the ac power mains to the LISN.
- The excess length of the power cord was folded back and forth in an 8-shape on a wooden strip with a vertical prong located on the top of the LISN case.
- The EUT was set-up in its typical configuration and operated in its various modes as described in this test report.
- A preliminary scan was made by using spectrum analyzer system with the detector function set to PEAK mode (9 KHz RBW, VBW > RBW), frequency span 150 kHz to 30 MHz.
- The maximum conducted emission for a given mode of operation was found by using the following step-by-step procedure:
  - Step 1. Monitor the frequency range of interest at a fixed EUT azimuth.
  - Step 2. Manipulate the system cables and peripheral devices to produce highest amplitude signal relative to the limit. Note the amplitude and frequency of the suspect signal.
  - Step 3. The effects of various modes of operation is examined. This is done by varying equipment operation modes as step 2 is being performed.
  - Step 4. After completing step 1 through 3, record EUT and peripheral device configuration, mode of operation, cable configuration, signal levels and frequencies for final test.
- Each highest signal level at the maximized test configuration was zoomed in a small frequency span on the spectrum analyzer's display (the manipulation of cables and peripheral devices and EUT operation modes might have to be repeated to obtain the highest signal level with the spectrum analyzer set to PEAK detector mode 10 KHz RBW and VBW > RBW). The spectrum analyzer was then set to CISPR QUASI-PEAK detector mode (9 KHz RBW, 1 MHz VBW) and AVERAGE detector mode (10 kHz RBW, 1 Hz VBW). The final highest RF signal levels and frequencies were record.

### 7.3. EQUIVALENT ISOTROPIC RADIATED POWER (EIRP)

- The following shall be applied to the combination(s) of the radio device and its intended antenna(e).
- If the RF level is user adjustable, all measurements shall be made with the highest power level available to the user for that combination.
- The following method of measurement shall apply to both conducted and radiated measurements.
- The radiated measurements are performed at the Ultratech Calibrated Open Field Test Site.
- The measurement shall be performed using normal operation of the equipment with modulation.

Test procedure shall be as follows:

#### Step 1: Duty Cycle measurements

- Using a spectrum analyzer with the frequency span set to 0 Hz and the sweep time set at a suitable value to capture the envelope peaks and the duty cycle of the transmitter output signal;
- The duty cycle of the transmitter,  $x = T_x \text{ on} / (T_x \text{ on} + T_x \text{ off})$  with  $0 < x < 1$ , is measure and recorded in the test report. For the purpose of testing, the equipment shall be operated with a duty cycle that is equal or more than 0.1.

#### Step 2: Calculation of Peak and Average EIRP

- The peak output power of the transmitter shall be determined using a wideband, calibrated RF Peak Power Meter with the power sensor with an integration period that exceeds the repetition period of the transmitter by a factor 5 or more. The observed value shall be recorded as “P” (in dBm);
- The Average EIRP shall be calculated from the above measured power output “A”, the observed duty cycle x, and the applicable antenna assembly gain “G” in dBi, according to the formula:

$$\text{Peak EIRP} = P + G$$
$$\text{Average EIRP} = \text{Peak EIRP} + 10\log(1/x)$$

Figure 1

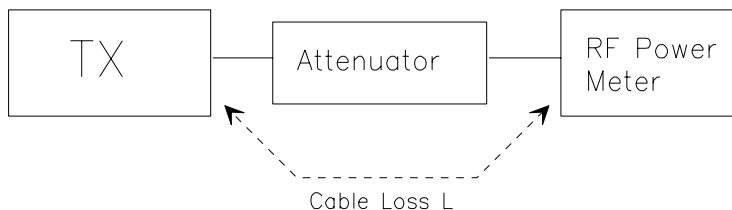

**Step 3:** Substitution Method. See Figure 2

- (a) The measurements was performed in the absence of modulation (un-modulated)
- (b) Test was performed at listed 3m open area test site (listed with FCC, IC, ITI, NVLAP, ACA & VCCI).
- (c) The transmitter under test was placed at the specified height on a non-conducting turntable (80 cm height)
- (d) The dipole test antenna was used and tuned to the transmitter carrier frequency.
- (e) The spectrum analyzer was tuned to transmitter carrier frequency. The test antenna was lowered or raised from 1 to 4 meters until the maximum signal level was detected.
- (f) The transmitter was rotated through  $360^\circ$  about a vertical axis until a higher maximum signal was received.
- (g) The test antenna was lowered or raised again from 1 to 4 meters until a maximum was obtained. This level was recorded.
- (h) The substitution dipole antenna and the signal generator replaced the transmitter and antenna under test in the same position, and the substitution dipole antenna was placed in vertical polarization. The test dipole antenna was lowered or raised as necessary to ensure that the maximum signal is stilled received.
- (i) The input signal to the substitution antenna was adjusted in level until an equal or a known related level to that detected from the transmitter was obtained in the test receiver. The maximum carrier radiated power is equal to the power supply by the generator.
- (j) The substitution antenna gain and cable loss were added to the signal generator level for the corrected ERP level.
- (k) Repeat steps (c) to (j) with the substitution antenna oriented in horizontal polarization.
- (l) Actual gain of the EUT's antenna is the difference of the measured ERP and measured RF power at the RF port. Correct the antenna gain if necessary.

**Figure 2**

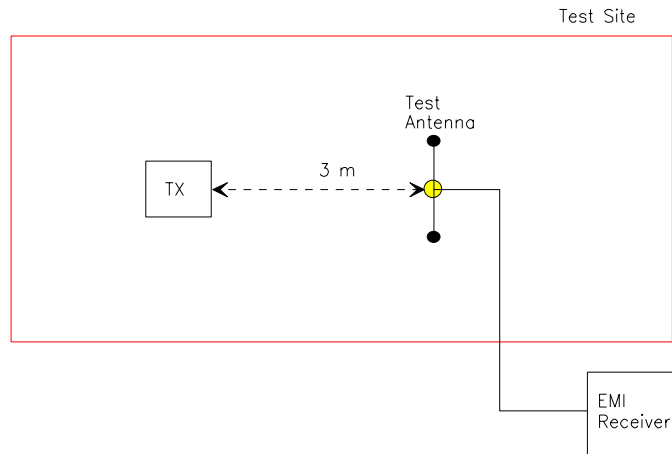
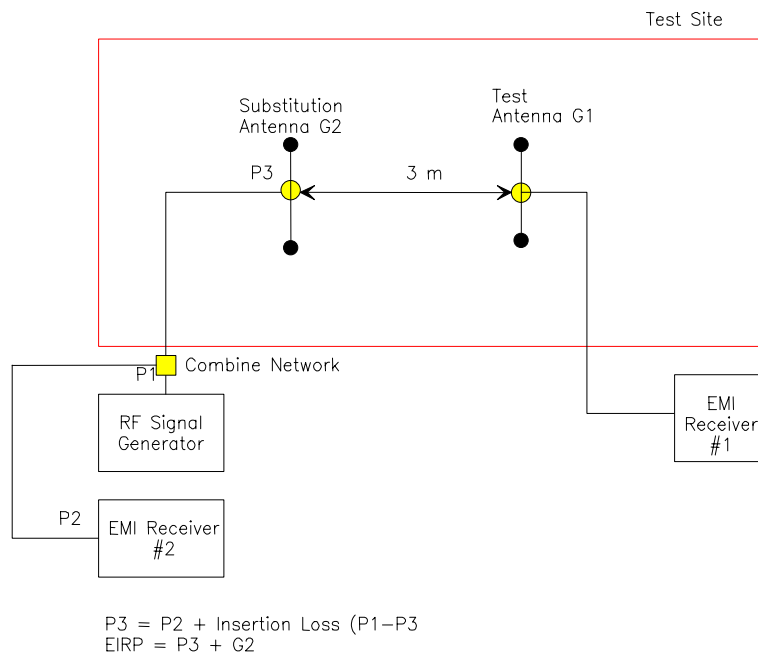

Figure 3



Use the following spectrum analyzer settings:

- Span = approximately 5 times the 20 dB BW, centered on a hopping channel
- RBW > 20 dB BW of the emission measured
- VBW = RBW
- Trace = max hold
- Allow the trace to stabilize
- Use the marker-to-marker function to set the marker to the peak of the emission.
- The indicated level is the peak output power (with the addition of the external attenuation and cable loss).
- The limit is specified in one of the subparagraph of this Section.
- Submit this plot.
- A peak responding power meter may be used instead of a spectrum analyzer.

## 7.4. SPURIOUS EMISSIONS (CONDUCTED & RADIATED)

For both conducted and radiated measurements, the spurious emissions were scanned from the lowest frequency generated by the EUT or 10 MHz whichever is lower to 10<sup>th</sup> harmonic of the highest frequency generated by the EUT.

### 7.4.1. Band-Edge and Spurious Emissions (Conducted)

#### Band-Edge Compliance of RF Conducted Emissions:

Use the following spectrum analyzer settings:

- The radio was connected to the measuring equipment via a suitable attenuator.
- Span = wide enough to capture the peak level of the emission operating on the channel closest to the band-edge, as well as any modulation products which fall outside of the authorized band of operation.
- RBW = 1 % of the span
- VBW  $\geq$  RBW
- Sweep = auto
- Detector function = peak
- Trace = max hold
- Allow the trace to stabilize
- Set the marker on the emission at the band-edge, or on the highest modulation product outside of the band, if this level is greater than that at the band-edge
- Enable the marker-delta function, then use the marker-to-peak function to move the marker to the peak of the in-band emission.
- The marker-delta value now displayed must comply with the limit specified
- Now, using the same instrument settings, enable the hopping function of the EUT
- Allow the trace to stabilize
- Follow the same procedure listed above to determine if any spurious emissions cause by the hopping function also comply with the specify limits.
- Submit this plot

#### Spurious RF Conducted Emissions:

Use the following spectrum analyzer settings:

- The radio was connected to the measuring equipment via a suitable attenuator.
- Span = wide enough to capture the peak level of the in-band-emission and all spurious emissions (e.g. harmonics) from the lowest frequency generated in the EUT up through the 10<sup>th</sup> harmonic. Typically, several plots are required to cover this entire span.
- RBW = 100 kHz
- VBW  $\geq$  RBW
- Sweep = auto
- Detector function = peak
- Trace = max hold
- Allow the trace to stabilize
- Set the marker on the any spurious emission recorded. The level displayed must comply with the limit specified in this Section.
- Submit this plot

### 7.4.2. Spurious Emissions (Radiated)

- The radiated emission measurements were performed at the UltraTech's 3 Meter Open Field Test Site (OFTS) situated in the Town of Oakville, province of Ontario. The Attenuation Characteristics of OFTS have been filed to FCC, Industry Canada, ACA/Austel, NVLap and ITI.
- Radiated emissions measurements were made using the following test instruments:
  1. Calibrated EMCO BiconiLog antenna in the frequency range from 30 MHz to 2000 MHz.
  2. Calibrated Emco Horn antennas in the frequency range above 1000 MHz (1GHz - 40 GHz).
  3. The test is required for any spurious emission or modulation product that falls in a Restricted Band, as defined in Section 15.205. It must be performed with the highest gain of each type of antenna proposed for use with the EUT. Use the following spectrum analyzer settings:
    - RBW = 100 kHz for  $f < 1\text{GHz}$  and  $\text{RBW} = 1\text{ MHz}$  for  $f \geq 1\text{ GHz}$
    - $\text{VBW} \geq \text{RBW}$
    - Sweep = auto
    - Detector function = peak
    - Trace = max hold
    - Follows the guidelines in ANSI C63.4-1992 with respect to maximizing the emission by rotating the EUT, measuring the emission while the EUT is situated in three orthogonal planes (if appropriate), adjusting the measurement antenna height and polarization, etc.. A pre-amp and highpass filter are required for this test, in order to provide the measuring system with sufficient sensitivity.
    - Allow the trace to stabilize.
    - The peak reading of the emission, after being corrected by the antenna correction factor, cable loss, pre-amp gain, etc.... is the peak field strength which comply with the limit specified in Section 15.35(b)

#### Calculation of Field Strength:

The field strength is calculated by adding the calibrated antenna factor and cable factor, and subtracting the Amplifier gain (if any) from the measured reading. The basic equation with a sample calculation is as follows:

$$\text{FS} = \text{RA} + \text{AF} + \text{CF} - \text{AG}$$

Where

FS	=	Field Strength
RA	=	Receiver/Analyzer Reading
AF	=	Antenna Factor
CF	=	Cable Attenuation Factor
AG	=	Amplifier Gain

Example: If a receiver reading of 60.0 dB $\mu$ V is obtained, the antenna factor of 7.0 dB/m and cable factor of 1.0 dB are added, and the amplifier gain of 30 dB is subtracted. The actual field strength will be:

$$\begin{aligned} \text{Field Level} &= 60 + 7.0 + 1.0 - 30 = 38.0 \text{ dB}\mu\text{V/m.} \\ \text{Field Level} &= 10^{(38/20)} = 79.43 \mu\text{V/m.} \end{aligned}$$

- Submit this test data
- Now set the VBW to 10Hz, while maintaining all of the other instrument settings. This peak level, once corrected, must comply with the limit specified in Section 15.209. If the dwell time per channel of the hopping signal is less than 100ms, then the reading obtained may be further adjusted by a “duty cycle correction factor”, derived from  $10\log(\text{dwell time}/100\text{ms})$  in an effort to demonstrate compliance with the 15.209.
- Submit test data

### **Maximizing The Radiated Emissions:**

- The frequencies of emissions was first detected. Then the amplitude of the emissions was measured at the specified measurement distance using required antenna height, polarization, and detector characteristics.
- During this process, cables and peripheral devices were manipulated within the range of likely configuration.
- For each mode of operation required to be tested, the frequency spectrum was monitored. Variations in antenna heights (from 1 meter to 4 meters above the ground plane), antenna polarization (horizontal plane and vertical plane), cable placement and peripheral placement were explored to produce the highest amplitude signal relative to the limit.

The maximum radiated emission for a given mode of operation was found by using the following step-by-step procedure:

- Step 1: Monitor the frequency range of interest at a fixed antenna height and EUT azimuth.
- Step 2: Manipulate the system cables to produce highest amplitude signal relative to the limit. Note the amplitude and frequency of the suspect signal.
- Step 3: Rotate the EUT 360 degrees to maximize the suspected highest amplitude signal. If the signal or another at a different frequency is observed to exceed the previously noted highest amplitude signal by 1 dB or more, go back to the azimuth and repeat Step 2. Otherwise, orient the EUT azimuth to repeat the highest amplitude observation and proceed.
- Step 4: Move the antenna over its full allowable range of travel (1 to 4 meters) to maximize the suspected highest amplitude signal. If the signal or another at a different frequency is observed to exceed the previously noted highest amplitude signal by 1 dB or more, return to Step 2 with the highest amplitude observation and proceed.
- Step 5: Change the polarization of the antenna and repeat Step 2 through 4. Compare the resulting suspected highest amplitude signal with that found for the other polarization. Select and note the higher of the two signals. This signal is termed the highest observed signal with respect to the limit for this EUT operational mode.
- Step 6: The effects of various modes of operation is examined. This is done by varying the equipment modes as steps 2 through 5 are being performed.
- Step 7: After completing steps 1 through 6, record the final highest emission level, frequency, antenna polarization and detector mode of the measuring instrument.

## 7.5. ALTERNATIVE TEST PROCEDURES

If the antenna conducted tests cannot be performed on this device, radiated tests show compliance with the peak output power limit specified in Section 15.247(b) and the spurious RF conducted emission limit specified in Section 15.247(c) are acceptable. As stated previously, a pre-amp, and, in the later case, a high pass filter, are required for the following measurements:

### 7.5.1. Peak Power Measurements

Calculate the transmitter's peak power using the following equation:

$$E = 30PG/d$$
$$P = (Ed)^2/30G$$

Where:

- E: measured maximum fundamental field strength in V/m. Utilizing a RBW, the 20 dB bandwidth of the emission  $VBW > RBW$ , peak detector function. Follow the procedures in C63.4-1992 with respect to maximizing the emission
- G is numeric gain of the transmitting antenna with reference to an isotropic radiator
- D is the distance in meters from which the field strength was measured
- P is the distance in meters from which the field strength was measured

### 7.5.2. Spurious RF conducted emissions

To demonstrate compliance with the spurious RF conducted emission requirement of Section 15.2479(c), use the following spectrum analyzer settings:

- Span = wide enough to fully capture the emission being measured
- RBW = 100 kHz
- Sweep = auto
- Detector function = peak
- Trace = max hold
- Measure the field strength of both the fundamental and all spurious emissions with these settings.
- Follow the procedures C63-4-1992 with respect to maximizing the emissions. The measured field strength of all spurious emissions must be below the measured field strength of the fundamental emission by the amount specified in Section 15.247©. Note that if the emission falls in a Restricted Band, as defined in Section 15.205, the procedure for measuring spurious radiated emissions listed above must be followed