



**Test report no. : 110398-4**

**Item tested : KX-TG8231**

**Type of equipment : UPCS Base**

**FCC ID : ACJ96NKX-TG8231**

**Client : Panasonic Communication Co., Ltd.**

**FCC Part 15, subpart D**

Isochronous UPCS Device  
1920 - 1930 MHz

**Industry Canada RSS-213, Issue 2**

2 GHz Licence-exempt Personal  
Communications Service Devices  
(LE-PCS)

**1 August 2008**

**Authorized by :** ..... *Egil Hauger* .....

Egil Hauger  
Technical Verificator



## CONTENTS

<b>1</b>	<b>GENERAL INFORMATION</b> .....	<b>3</b>
1.1	Testhouse Info.....	3
1.2	Client Information .....	3
1.3	Manufacturer (if other than client).....	3
<b>2</b>	<b>TEST INFORMATION</b> .....	<b>4</b>
2.1	Tested Item.....	4
2.2	Test Environment .....	5
2.3	Test Period .....	5
2.4	Test Engineer(s).....	5
2.5	Test Equipment .....	5
2.6	Other Comments .....	5
<b>3</b>	<b>TEST REPORT SUMMARY</b> .....	<b>6</b>
3.1	General.....	6
3.2	Test Summary .....	7
<b>4</b>	<b>TEST RESULTS</b> .....	<b>8</b>
4.1	Power Line Conducted Emissions.....	8
4.2	Out-of-band Emissions, Conducted.....	11
4.3	Receiver Spurious Emissions.....	12
<b>5</b>	<b>TEST SETUPS</b> .....	<b>13</b>
5.1	Conducted Emission Test.....	13
5.2	Power Line Conducted Emissions Test.....	13
<b>6</b>	<b>TEST EQUIPMENT USED</b> .....	<b>14</b>

## 1 GENERAL INFORMATION

### 1.1 Testhouse Info

Name : Nemko AS  
Address : Nemko Comlab  
Gåsevikveien 8, Box 96  
N-2027 Kjeller, NORWAY  
Telephone : +47 64 84 57 00  
Fax : +47 64 84 57 05  
E-mail: comlab@nemko.com  
FCC test firm  
registration # : 994405  
IC OATS  
registration # : 2040D-1  
Total Number  
of Pages: 14

### 1.2 Client Information

Name : Panasonic Communications Co. Ltd.  
Address : 1-62, 4-chome, Minoshima, Hakata-ku, Fukuoka 812-8531, Japan  
Telephone : +81 92 477 1405

**Contact:**

Name : Mr. Junji Sumi  
Telephone : +81 92 477 1405  
E-mail : sumi.junji@jp.panasonic.com

### 1.3 Manufacturer (if other than client)

Name : /  
Address : /  
Telephone : /  
E-mail : /

## 2 Test Information

### 2.1 Tested Item

Name :	Panasonic
FCC ID :	ACJ96NKX-TG8231
Industry Canada ID :	216A-KXTG8231
Model/version :	KX-TG8231
Serial number :	8DBQB120200
Hardware identity and/or version:	PQUP11527ZA-GW
Software identity and/or version :	/
Frequency Range :	1921.536 – 1928.448 MHz
Number of Channels :	5 RF Channels, 5x12 = 60 TDMA Duplex Channels
Type of Modulation :	GFSK (Gaussian Frequency Shift Keying)
User Frequency Adjustment :	None
Rated Output Power :	100 mW Peak Power
Type of Power Supply :	Panasonic PQLV219 AC Adaptor
Antenna Connector :	None
Number of Antennas :	2
Antenna Diversity Supported :	Yes

#### Description of Tested Device(s)

The tested equipment is a DECT base station which complies with ETSI EN 300 175. The frequencies have been reprogrammed, the output power reduced and the software updated to comply with the FCC requirements to an Isochronous UPCS device after FCC Part 15D.

The EUT is an responding device as described in ANSI C63.17 and is designed to operate together with a DECT portable part (i.e. a handset), which is then the initiating device.

## 2.2 Test Environment

Temperature:	21 – 24 °C
Relative humidity:	30 – 50 %
Normal test voltage:	120 V, 60 Hz AC

The values are the limit registered during the test period.

## 2.3 Test Period

Item received date:	2008-07-28
Test period :	from 2008-07-28 to 2008-07-30

## 2.4 Test Engineer(s)

Frode Sveinsen / Tore Moe

## 2.5 Test Equipment

See list of test equipment in clause 6.

## 2.6 Other Comments

This test report covers only re-tests for use with the new AC Adaptor PQLV219.

All tests except the Power line conducted emissions tests were performed in conducted mode with a temporary antenna connector.

### 3 TEST REPORT SUMMARY

#### 3.1 General

Manufacturer: Panasonic  
Model No.: KX-TG8231  
Serial No.: /

All measurements are traceable to national standards.

The tests were conducted on a sample of the equipment for the purpose of demonstrating compliance with FCC CFR47 Part 15D for Isochronous UPCS Devices and Industry Canada RSS-213 Issue 2.

The conducted test methods have been in accordance with ANSI C63.17-2006 where applicable.

Radiated tests were conducted in accordance with ANSI C63.4-2003. Radiated emissions are made in a 10m semi-anechoic chamber. A description of the test facility is on file with the FCC and Industry Canada.

- |  |   |
|--|---|
| <input type="checkbox"/> New Submission                        | <input checked="" type="checkbox"/> Production Unit |
| <input checked="" type="checkbox"/> Class II Permissive Change | <input type="checkbox"/> Pre-production Unit        |
| <b>PUB</b> Equipment Code                                      | <input type="checkbox"/> Family Listing             |

**THIS TEST REPORT APPLIES ONLY TO THE ITEM(S) AND CONFIGURATIONS TESTED.**

**Deviations from, additions to, or exclusions from the test specifications are described in "Summary of Test Data".**



**TEST REPORT NO: 110398-4**

TESTED BY :



Frode Sveinsen, Chief Engineer

DATE: 30 July 2008

Nemko Group authorizes the above named company to reproduce this report provided it is reproduced in its entirety and for use by the company's employees only. Any reproduction of parts of this report requires approval in writing from Nemko Group.

Any use which a third party makes of this report, or any reliance on or decisions to be made based on it, are the responsibility of such third parties. Nemko Group accepts no responsibility for damages suffered by any third party as a result of decisions made or actions based on this report.

### 3.2 Test Summary

Name of test	FCC CFR 47 Paragraph #	IC RSS-213 Paragraph #	Verdict
Power Line Conducted Emission	15.107(a) 15.207(a)	6.3 RSS-GEN 7.2.2	Complies
Out-of-band emissions	15.323(d)	6.7.1	Complies <sup>1</sup>
Receiver Spurious Emissions	N/A	6.8	Complies <sup>1</sup>

<sup>1</sup> This report covers only frequencies below 1 GHz.

## 4 TEST RESULTS

### 4.1 Power Line Conducted Emissions

Para. No.: 15.207 (a)

Test Performed By: Tore Moe	Date of Test: 30 July 2008
-----------------------------	----------------------------

Measurement procedure: ANSI C63.4-2003 using 50  $\mu$ H/50 ohms LISN.

Test Results: Complies

Measurement Data: See attached graph, (Peak detector).

Highest measured value (L1 and N):

All values are below the Average limit even when measured with Peak Detector.

Frequency	Detector	Measured value	Limit	Margin
KHz	Peak/QP/AV	dB $\mu$ V	dB $\mu$ V	dB
/	QP	/	/	/
/	AV	/	/	/
/	QP	/	/	/
/	AV	/	/	/

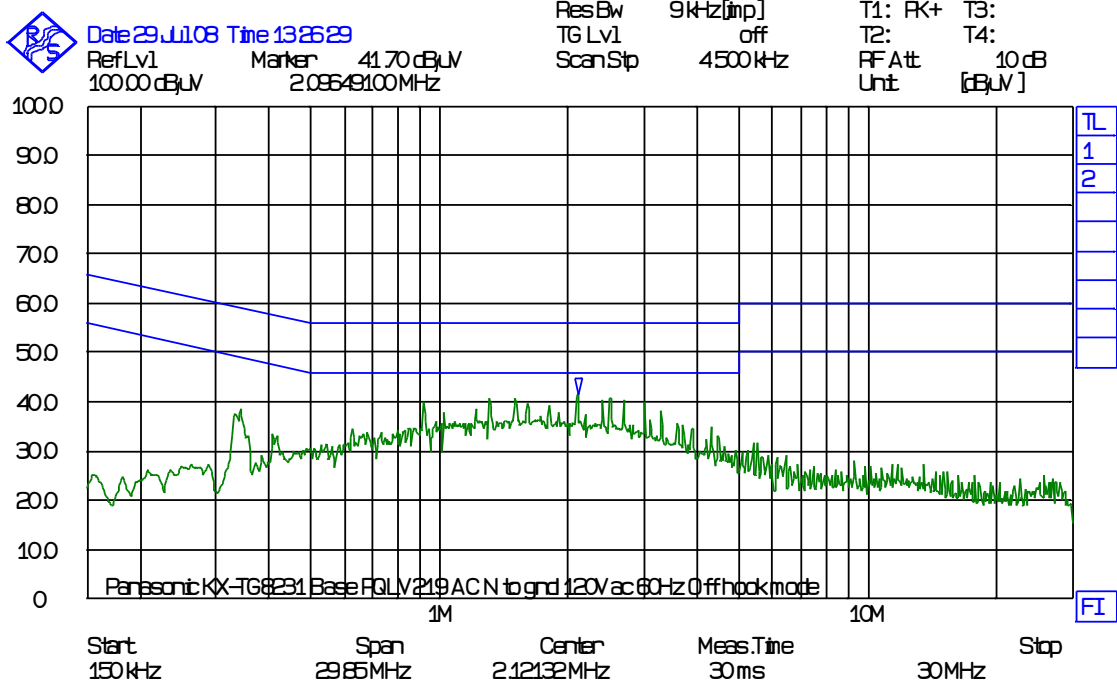

Phase N, Off Hook

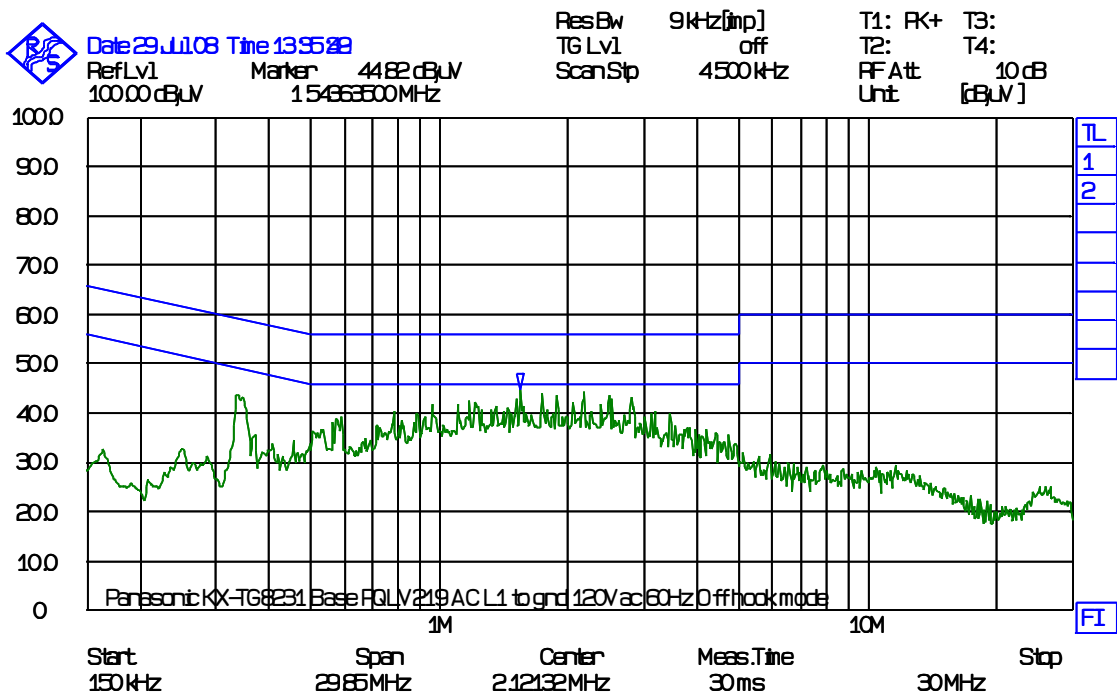

Phase L1, Off Hook

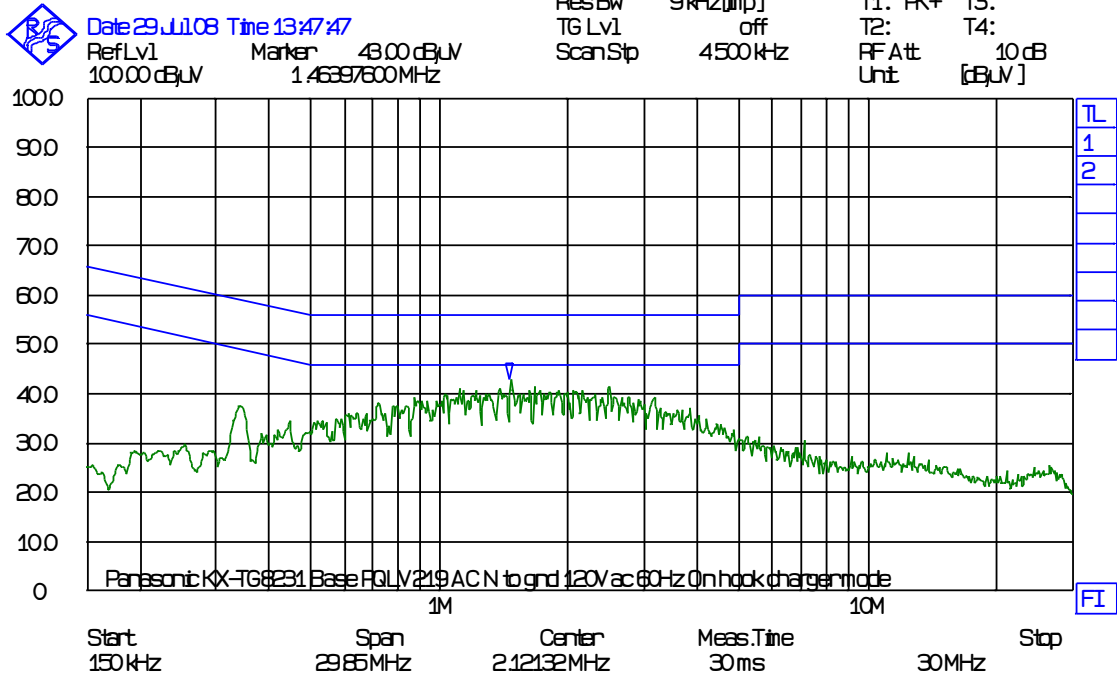

**Phase N, Charge Mode**

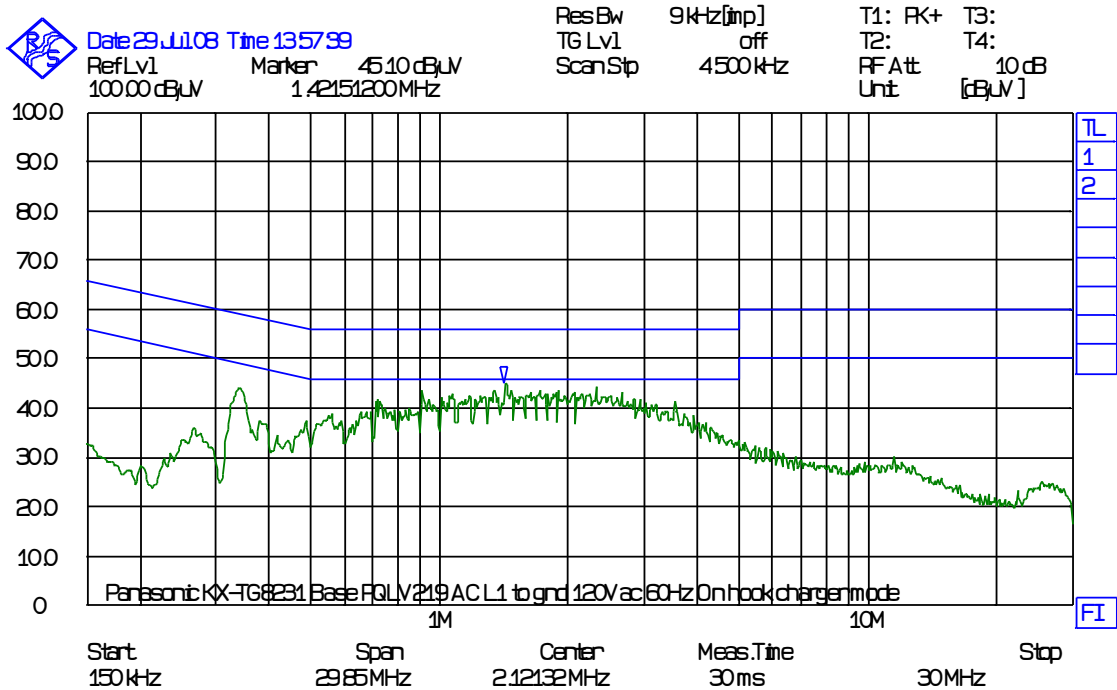

**Phase L1, Charge Mode**

## 4.2 Out-of-band Emissions, Conducted

### Test Method:

ANSI C63.17, clause 6.1.6.2.

### Test Results: Complies

### Measurement Data:

See plots.

### Requirements, FCC 15.323(d):

$f \leq 1.25\text{MHz}$  outside UPCS band :  $\leq -9.5\text{dBm}$   
 $1.25\text{MHz} \leq f \leq 2.5\text{MHz}$  outside UPCS band :  $\leq -29.5\text{ dBm}$   
 $f \geq 2.5\text{MHz}$  outside UPCS band :  $\leq -39.5\text{ dBm}$

## Out-of-Band Emissions, Conducted

### Lower Channel:

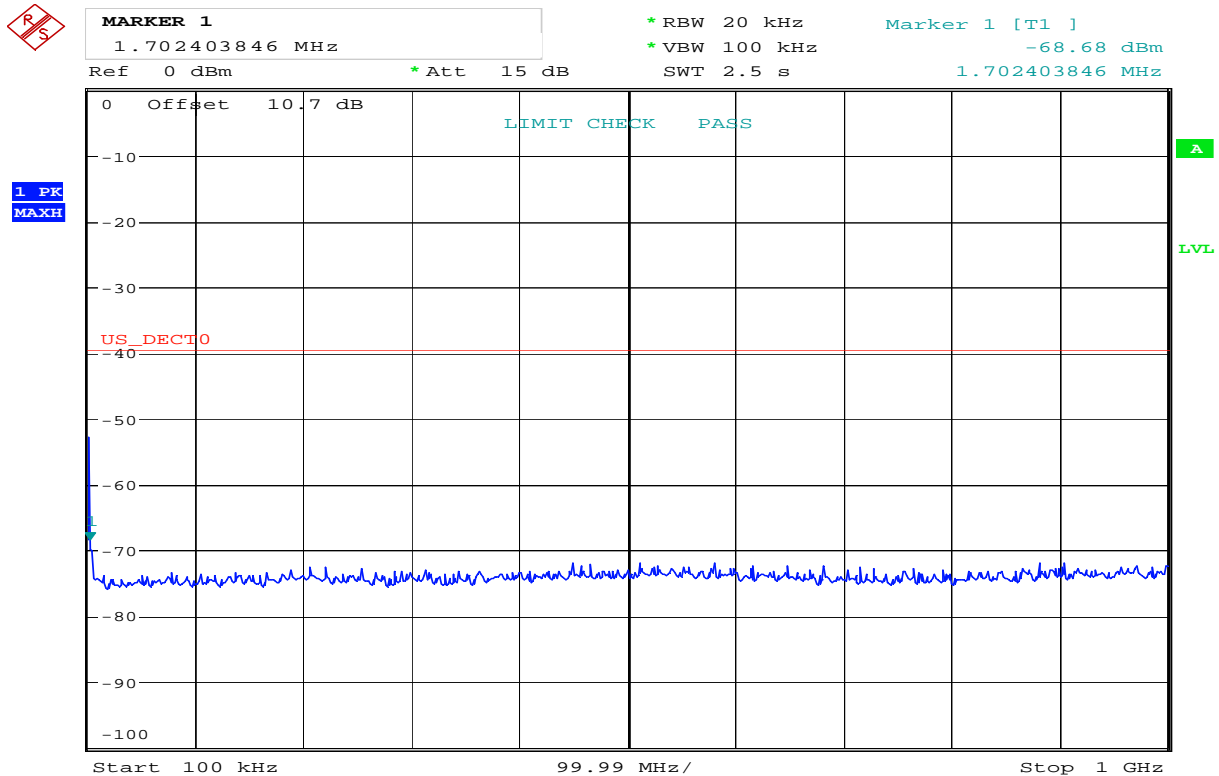

Date: 28.JUL.2008 14:46:17

### 4.3 Receiver Spurious Emissions

**Measurement Procedure:**

Industry Canada RSS-213 paragraph 6.8 and RSS-GEN paragraphs 4.8 and 6.

**Test results:**

Frequency MHz	Carrier No.	Measured Value Conducted dBm	Conducted Limit dBm	Margin dB
30 – 1000	all	< -76	-57	>19

The test was performed with the EUT in Receive-Only Mode with the Carrier disabled by software.

The test was only performed at frequencies below 1 GHz.

**Requirements, RSS-GEN Issue 2, clause 6**

The measurement can be performed either radiated or conducted.

**When measured Conducted:** no spurious signals appearing at the antenna terminals shall exceed 2 nW per any 4 kHz spurious frequency in the band 30-1000 MHz, or 5 nW above 1 GHz.

**When measured Radiated:** See Table 1 in RSS-GEN Issue 2, clause 6.

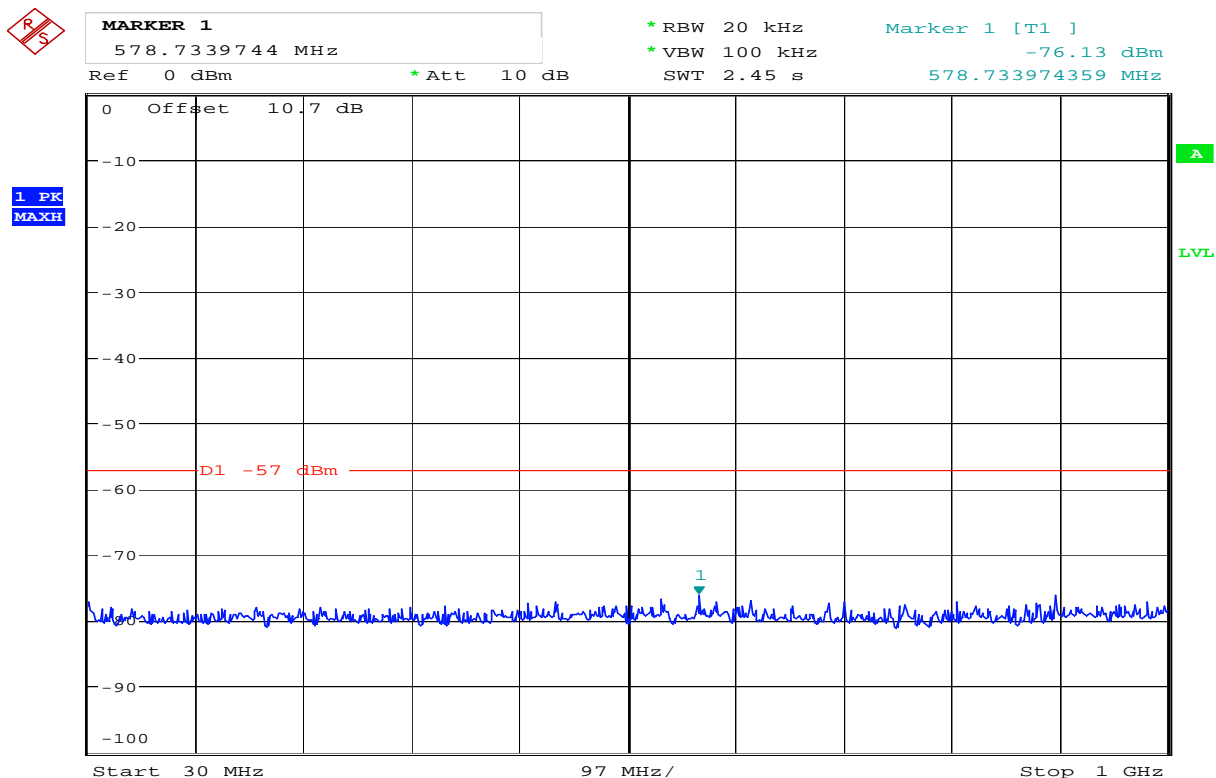

Date: 28.JUL.2008 14:40:31

**Receiver Conducted Emissions, 30 – 1000 MHz**

## 5 Test Setups

### 5.1 Conducted Emission Test

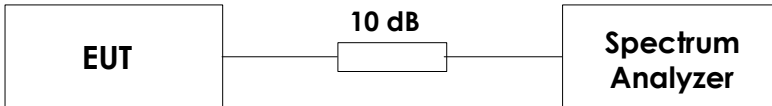

Test equipment included: 1, 13, 29

#### Test Set-up 3

This setup is used for all conducted emission tests.

### 5.2 Power Line Conducted Emissions Test

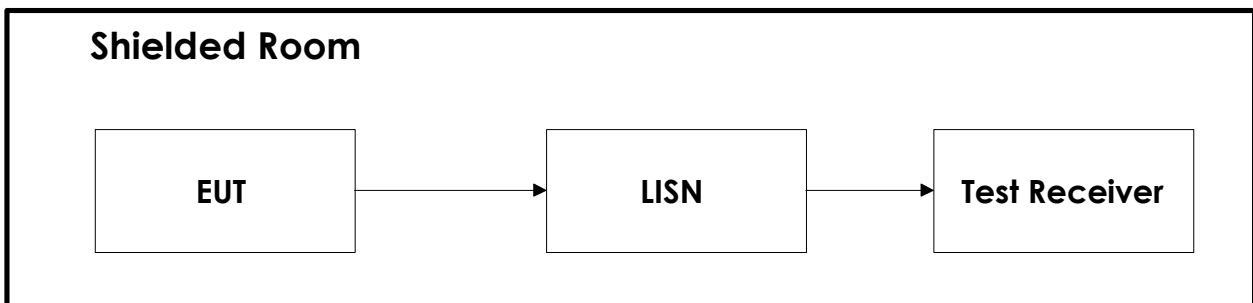

Test equipment: 12, 27, 28

#### Test Set-Up 5

## 6 Test Equipment Used

To facilitate inclusion on each page of the test equipment used for related tests, each item of test equipment and ancillaries are identified (numbered) by the Testhouse.

No.	Instrument/ancillary	Type of instrument/ancillary	Manufacturer	Ref. no.
1	FSEK30	Spectrum Analyzer	Rohde & Schwarz	LR 1337
2	SME03	Signal generator	Rohde & Schwarz	LR 1238
3	SMP04	Signal generator	Rohde & Schwarz	LR 1336
4	SMHU52	Signal generator	Rohde & Schwarz	LR 1240
5	53310A	Modulation Domain Analyzer	Hewlett Packard	LR 1483
6	81104A	Pulse-/ Pattern Generator	Agilent	LR 1502
7	8470B	Crystal Detector	Hewlett Packard	LR 1207
8	8449B	Preamplifier	Hewlett Packard	LR 1322
9	4HC3000/18000	High-pass filter	Trilithic	S.No.: 9849045
10	ESVS30	Measuring Receiver	Rohde & Schwarz	LR 1101
11	ESN	Measuring Receiver	Rohde & Schwarz	LR 1237
12	ESAI	Measuring Receiver	Rohde & Schwarz	LR 1090
13	6810.17B	Attenuator	Narda	LR1212
14	745-69	Step Attenuator	Narda	LR 1442
15	WE 1506A	Power Splitter	Weinchel	LR 244
16	WE 1506A	Power Splitter	Weinchel	LR 245
17	H-9	Hybrid	Anzac	LR 86
18	H-9	Hybrid	Anzac	LR 257
19	S212DS	RF Switch	Narda	LR 1244
20	3115	Horn Antenna	EMCO	LR 1226
21	PM7320-X	Horn Antenna	Sivers Lab	LR 102
22	DBF-520-20	Horn Antenna	Systron Donner	LR 100
23	638	Horn Antenna	Narda	LR 1480
24	HL223	Log-period Antenna	Rohde & Schwarz	LR 1261
25	HK116	Biconical Antenna	Rohde & Schwarz	LR 1260
26	HFH2-Z2	Loop Antenna	Rohde & Schwarz	LR 285
27	ESH3-Z5	Two Line V-Network	Rohde & Schwarz	LR 1076
28	80S	Signal Generator	Powertron	LT 502
29	FSU26	Spectrum Analyzer	Rohde & Schwarz	LR 1504
30	CMD60	DECT Tester	Rohde & Schwarz	LR 1335