

EMI Test Report No.: TR98-00037I

EMI TEST REPORT

CLASS B

INFORMATION TECHNOLOGY EQUIPMENT (ITE)

Model No. : KX-PS8102

KME

KME EMC TESTING LABORATORY

Issue Date : September 28, 1998

Kyushu Matsushita Electric Co., Ltd. (K M E)
Corporate Quality Assurance Division (C Q A D)

441-13 Nagahasu Tateishi-cho, Tosu-shi,
Saga-ken, 841-8585 Japan TEL 0942-84-8472

Do not reproduce except in full, without the written approval of
KME EMC TESTING LABORATORY

Table of Contents

EMI TEST REPORT ON ITE----- 3

1. Applicant	5. Measurement Procedure
2. Description of Device	6. Place of Measurement
3. Date of Receipt and Measurement	7. Facility Number
4. Regulations Applied	8. Measurement Results

[1] TEST RESULT

1. RADIATED EMISSION MEASUREMENTS -----	4, 5
2. AC POWERLINE CONDUCTED MEASUREMENTS -----	6, 7

[2] DESCRIPTION OF THE TEST EQUIPMENT

1. The equipment under test (EUT) -----	8,9
2. Type of Interface Cables -----	10
3. AC power cord -----	10

[3] PHOTOGRAPHS OF THE TEST SET-UP

1. RADIATED EMISSION MEASUREMENTS -----	11
2. AC POWERING CONDUCTED MEASUREMENTS -----	12

[4] TEST ARRANGEMENT AND LIST OF TEST INSTRUMENTS ---- 13,14

[5] TEST OPERATING CONDITION OF KX-PS8102----- 15

[5] ATTACHMENT ----- 16

Kyushu Matsushita Electric Co., Ltd.
 KME EMC TESTING LABORATORY
 441-13 Nagahasu tateishi-cho, Tosu-shi,
 Saga-ken, 841-8585 Japan
 TEL 0942-84-8472
 FAX 0942-84-8470

EMI TEST REPORT ON ITE

1. Applicant : Kyushu Matsushita Electric Co., Ltd.
 1-62, 4-Chome, Minoshima
 Hakata-Ku, Fukuoka, 812-8531 Japan
 Saga Division
 Kyushu Matsushita Electric Co., Ltd.
 1471 Murata-cho
 Tosu-shi, Saga-ken, 841-8501 Japan
2. Description of Device : **Color Scanner**
- a) Type of EUT : Desk-top Type
 b) Category : CLASS B
 INFORMATION TECHNOLOGY EQUIPMENT (ITE)
 c) Trade Name : Panasonic
 d) Model No. : KX-PS8102
 e) Serial No. : 8IMFDA00007
 f) Date of Manufacture : Sep 1998
 g) Power Supply : 120V AC 60Hz
3. Date of Receipt : Sep 1998
 Date of Measurement : Sep 24,25 1998
4. Regulations Applied : FCC Rules and Regulations Part 15
 Subpart B-Unitentional Radiators
5. Measurement Procedure : ANSI C63.4-1992
6. Place of Measurement : Kyushu Matsushita Electric Co., Ltd.
 KME EMC TESTING LABORATORY
7. Facility Number : (FCC) 31040/SIT /1300F2
8. Measurement Results : The results obtained from the measuring of
 the above-mentioned device are as shown in
 the attached sheets.

September 28, 1998

Chikito Kuwano

C. Kuwano

Quality manager

KME

[1] TEST RESULT

* TEST CONDITION OF EQUIPMENT UNDER TEST (EUT)

- 1 Configuration of EUT : Refer to the sheet No.8,9
- 2 Operating Condition : Stand by Mode,Running Mode
- 3 EUT Grounding : Grounded at the plug end of the line cord
- 4 Power Rating : 120V AC 60Hz

[1-1]RADIATED EMISSION MEASUREMENTS [30-2000 MHz][FCC](CLASS B)

[Test Site : Semi Anechoic chamber]

* TEST CONDITION OF INSTRUMENT

EUT Warm-up Time : 30 minutes

- 1) Resolution Bandwidth : 120kHz DATE September 24,1998
- 2) Detector Function : QP Temp.: 26°C Humi.:57%

(1-1) Stand by Mode

EMISSION FREQUENCY (MHz)	ANTENNA POLARITY (H,V)	METER READING at 3 m (dBμV)	ANTENNA FACTOR AND PREAMPGAIN (dB)	EMISSION LEVEL	FCC CLASS B
				at 3 m (dBμV/m)	at 3m (dBμV/m)
255.007	Hori.	40.7	-4.4	36.3	46.0
300.000	Hori.	36.6	-2.5	34.1	46.0
315.047	Hori.	39.3	-5.5	33.8	46.0
352.010	Hori.	39.4	-5.0	34.4	46.0
465.349	Hori.	40.0	-3.5	36.5	46.0
520.580	Hori.	40.6	-2.7	37.9	46.0
640.000	Hori.	35.6	0.9	36.5	46.0
1243.000	Hori.	39.8	-6.6	33.2	53.9
1280.120	Hori.	39.7	-6.4	33.3	53.9
35.605	Vert.	42.9	-8.2	34.7	40.0
44.179	Vert.	39.8	-11.3	28.5	40.0
58.541	Vert.	51.0	-16.0	35.0	40.0
81.090	Vert.	50.6	-17.7	32.9	40.0
99.734	Vert.	53.7	-16.0	37.7	43.5
199.435	Vert.	41.4	-6.5	34.9	43.5
296.828	Vert.	35.5	-2.6	32.9	46.0
531.844	Vert.	37.4	-2.1	35.3	46.0
679.995	Vert.	35.3	1.7	37.0	46.0
1260.080	Vert.	35.4	-6.5	28.9	53.9

Tested by :M.Horie

NOTES:1) The cable loss is included into the antenna factor and pre-amp gain.

2) Sample of calculation at 255.007 MHz

$$40.7(\text{dB}\mu\text{V}) - 4.4(\text{dB}) = 36.3(\text{dB}\mu\text{V}/\text{m})$$

Reviewed by : M.Horie *M. Horie*



(1-2) Running With The Program Mode

EMISSION FREQUENCY (MHz)	ANTENNA POLARITY (H, V)	METER READING at 3 m (dB μ V)	ANTENNA FACTOR AND PREAMP GAIN (dB)	EMISSION LEVEL	FCC CLASS B
				at 3 m (dB μ V/m)	at 3m (dB μ V/m)
35.672	Vert.	44.8	-8.2	36.6	40.0
60.257	Vert.	51.1	-16.5	34.6	40.0
64.947	Vert.	49.1	-17.1	32.0	40.0
81.465	Vert.	50.8	-17.7	33.1	40.0
99.734	Vert.	53.1	-14.0	39.1	43.5
199.435	Vert.	41.9	-6.5	35.4	43.5
255.007	Hori.	41.1	-6.3	34.8	46.0
319.994	Hori.	42.5	-5.5	37.0	46.0
465.349	Hori.	40.1	-3.5	36.6	46.0
531.837	Hori.	40.6	-2.1	38.5	46.0
640.000	Hori.	36.8	0.9	37.7	46.0
1279.974	Hori.	40.2	-6.4	33.8	53.9
1344.005	Hori.	40.8	-6.0	34.8	53.9
1813.000	Hori.	32	-3.3	28.7	53.9

Tested by : M.Horie

NOTES:1) The cable loss is included into the antenna factor and pre-amp gain.

2) Sample of calculation at 35.672 MHz
 $44.8 \text{ (dB}\mu\text{V)} - 8.2 \text{ (dB)} = 36.6 \text{ (dB}\mu\text{V)}$

Reviewed by : M.Horie *M. Horie*

2. AC POWERLINE CONDUCTED MEASUREMENTS [FCC Part15](CLASS B)

[Test Site : Shielded Room]

* TEST CONDITION OF INSTRUMENT

EUT Warm-up Time : 30 minutes

1) Resolution Bandwidth : 9 kHz

DATE : September 25, 1998

2) Detector Function : QP

Temp.: 28 °C Humi.: 62%

(2-1) Stand by MODE

	EMISSION FREQUENCY (MHz)	METER READING (dB μ V)	LISN FACTOR (dB)	EMISSION	FCC
				LEVEL	CLASS B
				at 3 m	at 3m
				(dB μ V)	(dB μ V)
Va	0.7041	17.9	-0.3	17.6	47.9
	0.8580	21.2	-0.2	21.0	47.9
	1.8908	16.7	-0.3	16.4	47.9
	2.4050	24.8	-0.3	24.5	47.9
	3.0845	17.8	-0.2	17.6	47.9
	20.8919	35.6	0.2	35.8	47.9
Vb	0.7041	18.1	-0.3	17.8	47.9
	0.8580	19.2	-0.2	19.0	47.9
	1.8908	13.8	-0.3	13.5	47.9
	2.4050	25.0	-0.3	24.7	47.9
	3.0845	16.6	-0.2	16.4	47.9
	20.8919	35.6	0.2	35.8	47.9

Tested by : M. Horie

NOTES:1) LISN factor includes the cable loss for 5 meter.

2) Sample of calculation at 0.7041 MHz

17.9 (dB μ V) -0.3 (dB)= 17.6 (dB μ V)

Reviewed by : M.Horie

M. Horie

(2-2) Running MODE

	EMISSION FREQUENCY (MHz)	METER READING (dB μ V)	LISN FACTOR (dB)	EMISSION LEVEL	FCC CLASS B
				at 3 m (dB μ V/m)	at 3m (dB μ V/m)
Va	0.7400	21.0	-0.3	20.7	47.9
	0.9908	25.3	-0.2	25.1	47.9
	1.9798	25.4	-0.3	25.1	47.9
	2.5171	21.6	-0.2	21.4	47.9
	3.3494	27.3	-0.2	27.1	47.9
	12.0662	19.2	-0.1	19.1	47.9
	20.8969	35.8	0.2	36.0	47.9
	23.9500	16.2	0.3	16.5	47.9
28.6361	32.7	0.4	33.1	47.9	
Vb	0.7400	27.1	-0.3	26.8	47.9
	0.9908	25.9	-0.2	25.7	47.9
	1.9798	26.0	-0.3	25.7	47.9
	2.5171	18.4	-0.2	18.2	47.9
	3.3494	27.9	-0.2	27.7	47.9
	12.0662	16.9	-0.1	16.8	47.9
	20.8969	17.2	0.2	17.4	47.9
	23.9500	12.6	0.3	12.9	47.9
28.6361	32.6	0.4	33.0	47.9	

Tested by : M. Horie

NOTES:1) LISN factor includes the cable loss for 5 meter.

2) Sample of calculation at 0.7400 MHz
 21.0 (dB μ V) -0.3 (dB) = 20.7 (dB μ V)

Reviewed by : M.Horie M. Horie

[2] DESCRIPTION OF THE TEST EQUIPMENT

[2-1] Configuration of EUT
(RADIATED EMISSION)

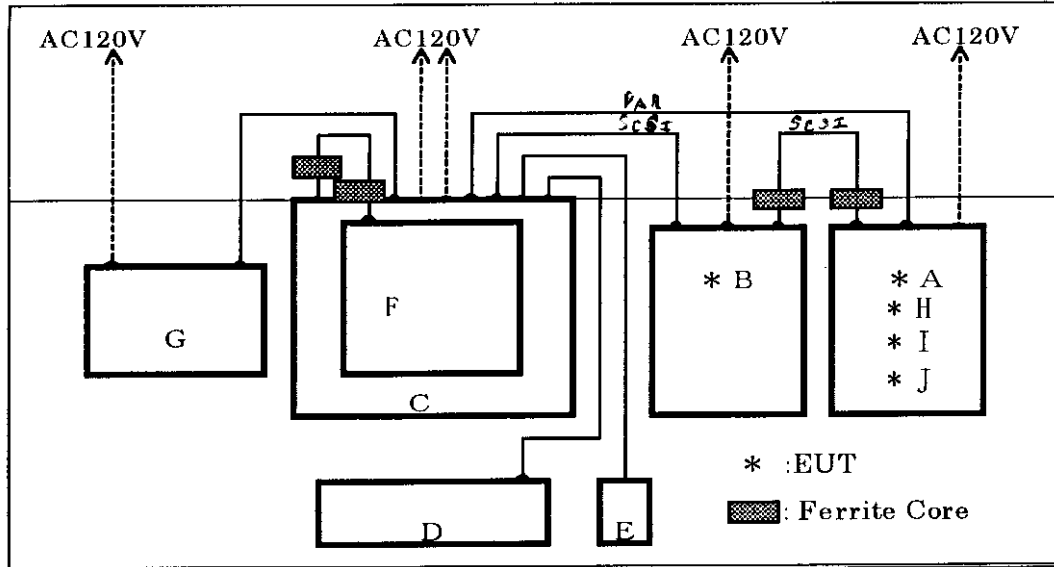

EUT Table : 2.1(W) × 1.0(D) × 0.8(H) (M)

■ : Ferrite core

*NOTE,
PRINTER,
SCANNER AND
SCSI CABLE
WITH 2
FERRITE CORES
AS MARKED
TOGETHER.*

		Model No. [Manufacture	Serial No.	FCC ID/DoC
A	Color Printer	KX-PS8101 [K M E]	8IMFCA00007	ACJ5Z6KX-PS8101
B	Color Scanner	KX-PS8102 [K M E]	8IMFDA00007	ACJ5Z6KX-PS8102
C	Personal Computer	VECTRA VL5/166 [H P]	SG71201025	DoC
D	Keyboard	RT6656TWJP	31470143	AQ6-MTN4C15
E	Mouse	M-S34 [H P]	LZA72556796	DZL211029
F	CRT Display	D2817A [H P]	JP52200864	ACJ9312120
G	Dot Printer	KX-P3200 [K M E]	5LMDMA01052	ACJ5Z6KX-P3200
	(OPTION)			
H	32MB DIMM Expansion ×3 pcs	KX-PEMD2 [K M E]	8IAMA00117 ~00119	N.A
I	HDD print data spooler	KX-PDHD1 [K M E]	8IAMA00107	N.A
J	2nd Cassette Feeder (with 2paper Tray)	KX-PCSF1 [K M E]	7KBGA01186	N.A

DoC: Device for Declaration of Conformity

[2-2] Configuration of EUT
 (AC POWERLINE CONDUCTED)

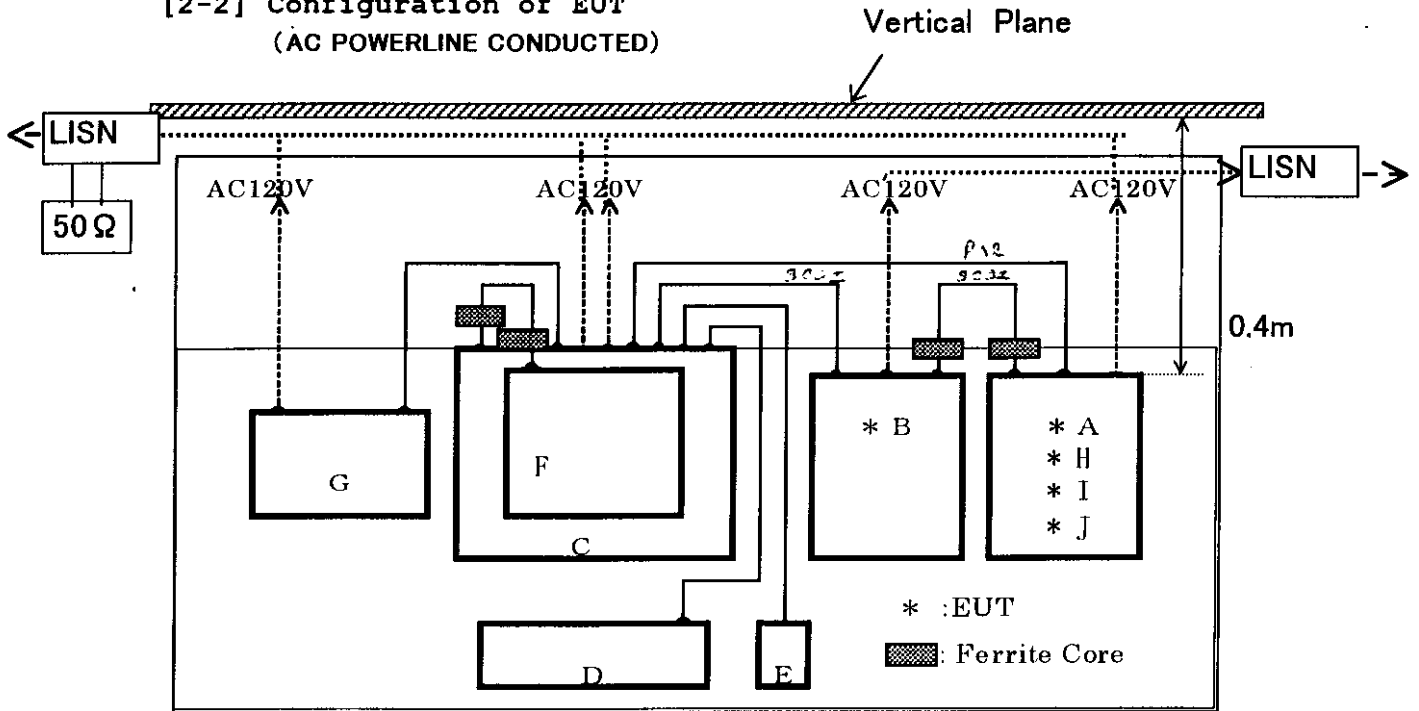

EUT Table : 2.1(W) × 1.0(D) × 0.8(H) (M)

		Model No. [Manufacture]	Serial No.	FCC ID/DoC
A	Color Printer	KX-PS8101 [K M E]	8IMFCA00007	ACJ5Z6KX-PS8101
B	Color Scanner	KX-PS8102 [K M E]	8IMFDA00007	ACJ5Z6KX-PS8102
C	Personal Computer	VECTRA VL5/166 [H P]	SG71201025	DoC
D	Keyboard	RT6656TWJP [H P]	31470143	AQ6-MTN4C15
E	Mouse	M-S34 [H P]	LZA72556796	DZL211029
F	CRT Display	D2817A [H P]	JP52200864	ACJ9312120
G	Dot Printer	KX-P3200 [K M E]	5LMDMA01052	ACJ5Z6KX-P3200
	(OPTION)			
H	32MB DIMM Expansion ×3 pcs	KX-PEMD2 [K M E]	8IAMA00117 ~00119	N.A
I	HDD print data spooler	KX-PDHD1 [K M E]	8IAMA00107	N.A
J	2nd Cassette Feeder (with 2paper Tray)	KX-PCSF1 [K M E]	7KBGA01186	N.A

DoC: Device for Declaration of Conformity

[2-2] Type of Interface Cables

[Main Frame]	[Peripheral]	[Length]	Number
*Color Printer (A)	--- Personal Computer (C) Metallic Hoods, Shielded Circular Cable	2.0 m	1
*Color Scanner (B)	--- Personal Computer (C) Metallic Hoods, Shielded Circular Cable	2.0 m	1
*Color Scanner (B)	--- Color Printer (A) Metallic Hoods, Shielded Circular Cable (Ferrite core at the end of the cable)	1.2 m	1
*Key board (D)	--- Personal Computer (C) Metallic Hoods, Shielded Circular Cable	1.7 m	1
*Mouse (E)	--- Personal Computer (C) Metallic Hoods, Shielded Circular Cable	1.8 m	1
*CRT Display (F)	--- Personal Computer (C) Metallic Hoods, Shielded Circular Cable (Ferrite core at the end of the cable)	1.6 m	1
*Dot Printer (G)	--- Personal Computer (C) Metallic Hoods, Shielded Circular Cable	2.0 m	1

[2-3] AC Power Cord

[Main Frame]	[Peripheral]	[Length]	Number
*Color Printer (A)	--- Plastic Hoods, Unshielded Circular Cable	2.0 m	1
*Color Scanner (B)	--- Plastic Hoods, Unshielded Circular Cable	2.0 m	1
*Personal Computer (C)	--- Plastic Hoods, Unshielded Circular Cable	2.0 m	1
*CRT Display (F)	--- Plastic Hoods, Unshielded Circular Cable	2.0 m	1
*Dot Printer (G)	--- Plastic Hoods, Unshielded Circular Cable	2.0 m	1

[2-4] Arrangement of the Interface Cables

Refer to the photographs.

These interface cables were positioned so as to produce the highest maximum at every frequency between 30MHz and 2000 MHz, being within the manner assumed to be a typical operating condition.

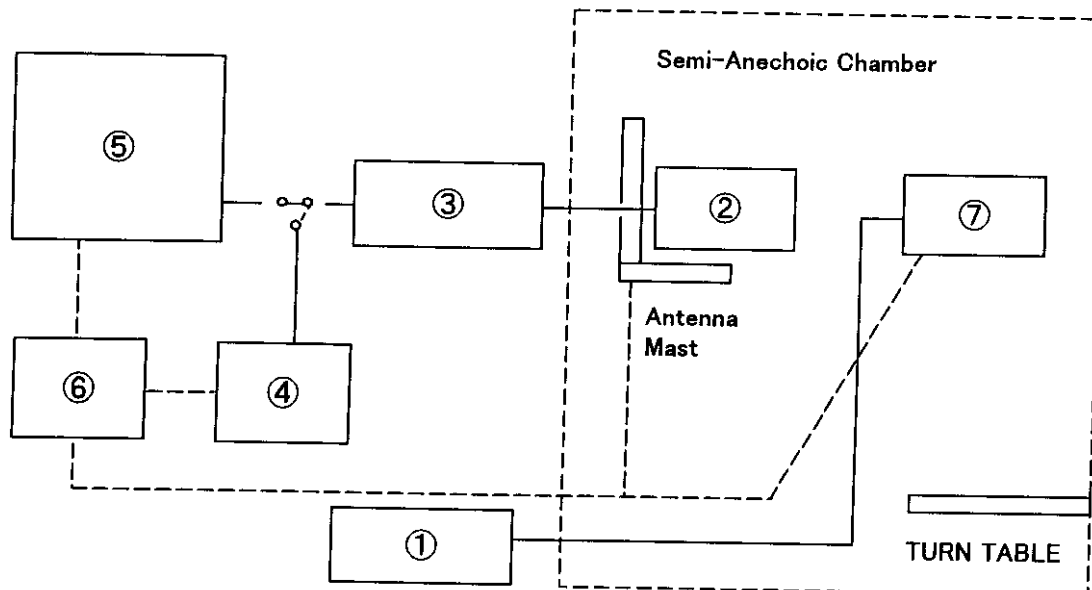
[4] TEST ARRANGEMENT AND LIST OF INSTRUMENTS**[4-1] TEST EQUIPMENTS OF RADIATED EMISSION MEASUREMENTS**

	Apparatus	Model No. (Manufacture)	Spec.	Calibrated Untill	Serial No.
①	1 phase AC SUPPLY	FUK-23749-1 (NF)	50/60Hz MAX 1Φ 265 V	---	---
②	Antenna	VHA9103 UHA9105 BBA9106 UHALP9107 (Shwarzbeck) 3115 (EMCO)	30M-300MHz (Dipole) 300M-1000MHz(Dipole) 30M-300MHz (Broad) 300M-1000MHz(Broad) 1G-18GHz(HORN)	June.1999 June.1999 April, 1999 April, 1999 July.1999	VHA91031457 VHA91052101 91031450 1728 4220
③	Pre-Amplifier	8447D (hp) 8449B (hp)	0.1M-1300MHz 1G-26.5GHz	Nov. 1999 July.1999	2944A08715 3008A00544
④	Spectrum Analyzer	R3371A (Advantest)	100Hz~26.5GHz	Nov. 1998	6830014
⑤	EMI Receiver	ESVS10 (R&S) 8566B (hp)	20M-1000MHz 100Hz-2.5GHz /2G-22GHz	Nov. 1998 July.1999	844594/005 3221A01468
⑥	Personal Computer	340 (IBM)	---	---	---
⑦	EUT	KX-PS8102	---	---	8IMFDA00007

[4-2] TEST EQUIPMENTS OF CONDUCTED MEASUREMENTS

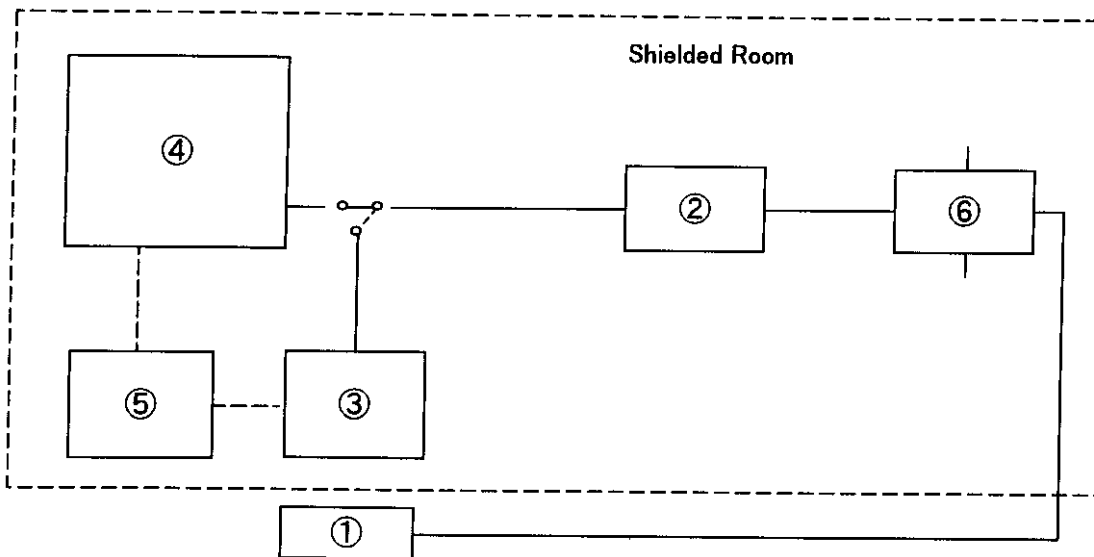

	Apparatus	Model No. (Manufacture)	Spec.	Calibrated Untill	Serial No.
①	1 phase AC SUPPLY	EA-2100A (NF)	40Hz~500Hz 1Φ 240 V MAX 1Φ 2 KVA	---	---
②	LISN	KNW407 (KYORITSU)	1Φ 250 V 15 A	Dec. 1998 Dec. 1998	8-1345-4 8-1345-3
③	Spectrum Analyzer	R3361C (Advantest)	9kHz~2.6GHz	Dec. 1998	61720502
④	EMI Receiver	ESHS10 (R&S)	9KHz~30MHz	Nov. 1998	844077/014
⑤	Personal Computer	340 (IBM)	---	---	---
⑥	EUT	KX-PS8102	---	---	8IMFDA00007

[5] TEST OPERATING CONDITION OF KX-PS8102

TEST PROGRAM (mode of SCSI Interface)

The EUT (KX-PS8102) is designed Color Scanner to be used exclusively by Microsoft Windows system. And the EUT functions with Printer (KX-PS8101) as color copier.

Then the exercise program used during radiated and conducted emission test exercised on Microsoft Windows 95 system in a manner similar to typical use.

The exercise program consists of that following contents are repeated.

- (1) A personal computer takes in image data from the EUT, through the SCSI port. (EUT Scanner Test)
- (2) A personal computer starts the Copier mode toward the EUT, and the image data scanned from the EUT is printed out it with the Printer. (EUT Copier Test)
- (3) "H" strings are printed out to the Printer, through the parallel port. And same time "H" string are indicated on the monitor by the program on Microsoft Windows. (Printer Test)

[5] ATTACHMENT

5.1 RADIATED EMISSION MEASUREMENTS

[Attachment Sheet No.]

- * QP Data ----- Sheet 1 of 6 Sheets
Stand By mode(Horizontal/Vertical, 30-1000MHz)
- * QP Data ----- Sheet 2 of 6 Sheets
Running mode(Horizontal/Vertical, 30-1000MHz)
- * QP Data ----- Sheet 3 of 6 Sheets
Stand By mode(Horizontal/Vertical, 1GHz-2GHz)
- * QP Data ----- Sheet 4 of 6 Sheets
Running mode(Horizontal/Vertical, 1GHz-2GHz)

5.2 AC POWERLINE CONDUCTED MEASUREMENTS

- * QP Data ----- Sheet 5 of 6 Sheets
Stand By mode(Va/Vb, 0.45-30MHz)
- * QP Data ----- Sheet 6 of 6 Sheets
Running mode(Va/Vb, 0.45-30MHz)