

Amber Helm Development L.C.

92723 Michigan Hwy-152

Sister Lakes, Michigan 49047 USA

Tel: 888-847-8027

EMC Test Report

TI114A-1702195TX

Issued: October 24, 2017

regarding

USA: CFR Title 47, Part 15.247 (Emissions)
Canada: IC RSS-247/GENe (Emissions)

for



ACJ-TI114A

Category: Bluetooth Head Unit

Judgements:

FCC 15.247 ISED RSS-247 Compliant

Tested: September 28, 2017



NVLAP LAB CODE 200129-0

Prepared for:

Panasonic Automotive S.C. of A.

776 Highway 74S, Peachtree City Georgia 30269 USA

Phone: 201-348-7760

Fax: 201-348-7760

Contact: Ben Botros

Ben.Botros@us.panasonic.com

Data Recorded by:

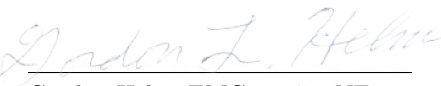
Gordon Helm, EMC-002401-NE

Reviewed by:

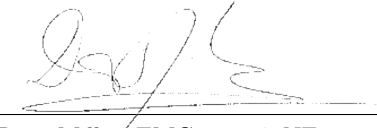
Dave Miller, EMC-003027-NE

Prepared by:

Dr. Joseph Brunett, EMC-002790-NE

Date of Issue:

October 24, 2017

Revision History

Rev. No.	Date	Details	Revised By
r0	October 24, 2017	Initial Release.	J. Brunett
r1	October 31, 2017	Correct Typos.	J. Brunett

Contents

Revision History	2
Table of Contents	2
1 Test Report Scope and Limitations	5
1.1 Laboratory Authorization	5
1.2 Report Retention	5
1.3 Subcontracted Testing	5
1.4 Test Data	5
1.5 Limitation of Results	5
1.6 Copyright	5
1.7 Endorsements	5
1.8 Test Location	6
1.9 Traceability and Equipment Used	6
2 Test Specifications and Procedures	7
2.1 Test Specification and General Procedures	7
3 Configuration and Identification of the Equipment Under Test	8
3.1 Description and Declarations	8
3.1.1 EUT Configuration	8
3.1.2 Modes of Operation	8
3.1.3 Variants	9
3.1.4 Test Samples	9
3.1.5 Functional Exerciser	9
3.1.6 Modifications Made	9
3.1.7 Production Intent	10
3.1.8 Declared Exemptions and Additional Product Notes	10
4 Emissions	11
4.1 General Test Procedures	11
4.1.1 Radiated Test Setup and Procedures	11
4.1.2 Conducted Emissions Test Setup and Procedures	13
4.1.3 Power Supply Variation	13
4.2 Intentional Emissions	14
4.2.1 Duty and Transmission Cycle, Pulsed Operation	14
4.2.2 Hopping Channel Dwell Time	14
4.2.3 Channel Bandwidth	16
4.2.4 Number of Hopping Channels	18
4.2.5 Channel Separation	18
4.2.6 Effective Isotropic Radiated Power	20
4.3 Unintentional Emissions	22
4.3.1 Transmit Chain Spurious Emissions	22
4.3.2 Relative Transmit Chain Spurious Emissions	23

5 Measurement Uncertainty and Accreditation Documents

List of Tables

1	Test Site List.	6
2	Equipment List.	6
3	EUT Declarations.	8
4	Pulsed Emission Characteristics (Duty Cycle).	14
5	Hopping Channel Dwell Time.	14
6	Intentional Emission Bandwidth.	16
7	Measured Number of Hopping Channels.	18
8	Measured Channel Separation.	18
9	Radiated Power Results.	20
10	Transmit Chain Spurious Emissions.	22
11	Measurement Uncertainty.	24

List of Figures

1	Photos of EUT.	8
2	EUT Test Configuration Diagram.	9
3	Radiated Emissions Diagram of the EUT.	11
4	Radiated Emissions Test Setup Photograph(s).	12
5	Conducted RF Test Setup Photograph(s).	13
6	Example Plots of Duty Cycle and Channel Dwell Time.	15
7	Intentional Emission Bandwidth.	17
8	Measured Channel Separation.	19
9	Conducted RF Power Plots	21
10	Conducted Transmitter Emissions Measured.	23
11	Accreditation Documents	24

1 Test Report Scope and Limitations

1.1 Laboratory Authorization

Test Facility description and attenuation characteristics are on file with the FCC Laboratory, Columbia, Maryland (FCC Reg. No: 90413) and with ISED Canada, Ottawa, ON (File Ref. No: IC3161). Amber Helm Development L.C. holds accreditation under NVLAP Lab Code 200129-0 and includes within its scope CFR Title 47 Part 15 Subparts B and C.

1.2 Report Retention

For equipment verified to comply with the regulations herein, the manufacturer is obliged to retain this report with the product records for the life of the product, and no less than ten years. A copy of this Report will remain on file with this laboratory until October 2027.

1.3 Subcontracted Testing

This report does not contain data produced under subcontract.

1.4 Test Data

This test report contains data included within the laboratories scope of accreditation.

1.5 Limitation of Results

The test results contained in this report relate only to the item(s) tested. Any electrical or mechanical modification made to the test item subsequent to the test date shall invalidate the data presented in this report. Any electrical or mechanical modification made to the test item subsequent to this test date shall require reevaluation.

1.6 Copyright

This report shall not be reproduced, except in full, without the written approval of Amber Helm Development L.C..

1.7 Endorsements

This report shall not be used to claim product endorsement by any accrediting, regulatory, or governmental agency.

1.8 Test Location

The EUT was fully tested by **Amber Helm Development L.C.**, 92723 Michigan Hwy-152, Sister Lakes, Michigan 49047 USA. Table 1 lists all sites employed herein. Specific test sites utilized are also listed in the test results sections of this report.

Table 1: Test Site List.

Description	Location	Quality Num.
OATS (3m & 10m)	92723 Michigan Hwy-152, Sister Lakes, Michigan 49047 USA	OATSA

1.9 Traceability and Equipment Used

Pertinent test equipment used for measurements at this facility is listed in Table 2. The quality system employed at Amber Helm Development L.C. has been established to ensure all equipment has a clearly identifiable classification, calibration expiry date, and that all calibrations are traceable to the SI through NIST, other recognized national laboratories, accepted fundamental or natural physical constants, ratio type of calibration, or by comparison to consensus standards.

Table 2: Equipment List.

Description	Manufacturer/Model	SN	Quality Num.	Last Cal By / Date Due
BiconiLog Antenna	EMCO / 3142	1169	BILO3142	Lib.Labs / May-2018
(3m) RG8 Coax	CS-3227 / CS-3227	C060914	CS3227	AHD / Mar-2018
EMI Receiver	HP / 85460A/85462A	3704A00422, 3807A00465	HP8546A	Techmaster / Apr-2018
(3m) LMR-400 Coax	AHD / LMR400	C090804	LMR400	AHD / Mar-2018
(LCI) DS Coax	AHD / RG58/U	920809	RG58U	AHD / Jan-2018
(10-m) Amelco Coax	AHD / RG213U	9903-10ab	RG213U	AHD / Mar-2018
Double Ridged Horn	EMCO / 3115	2788	RH3115	Lib.Labs. / July-2018
Double Ridged Horn	Cobham / H-1798	190	RHCOB1840	Lib.Labs. / Jul 2018

2 Test Specifications and Procedures

2.1 Test Specification and General Procedures

The ultimate goal of Panasonic Automotive S.C. of A. is to demonstrate that the Equipment Under Test (EUT) complies with the Rules and/or Directives below. Detailed in this report are the results of testing the Panasonic Automotive S.C. of A. ACJ-TI114A for compliance to:

Country/Region	Rules or Directive	Referenced Section(s)
United States	Code of Federal Regulations	CFR Title 47, Part 15.247
Canada	ISED Canada	IC RSS-247/GENe

It has been determined that the equipment under test is subject to the rules and directives above at the date of this testing. In conjunction with these rules and directives, the following specifications and procedures are followed herein to demonstrate compliance (in whole or in part) with these regulations.

ANSI C63.4:2014	"Methods of Measurement of Radio-Noise Emissions from Low-Voltage Electrical and Electronic Equipment in the Range of 9 kHz to 40 GHz"
ANSI C63.10:2013 (USA)	"American National Standard of Procedures for Compliance Testing of Unlicensed Wireless Devices"
FCC DA 00-705	"Filing and Measurement Guidelines for Frequency Hopping Spread Spectrum Systems"
TP0102RA	"AHD Internal Document TP0102 - Radiated Emissions Test Procedure"
ISED Canada	"The Measurement of Occupied Bandwidth"

3 Configuration and Identification of the Equipment Under Test

3.1 Description and Declarations

The EUT is a vehicular Bluetooth transceiver. The EUT is approximately 20 x 17 x 13 cm in dimension, and is depicted in Figure 1. It is powered by 13.4 VDC vehicular power system. This product is used in a consumer motor vehicle as a Bluetooth interface Table 3 outlines provider declared EUT specifications.

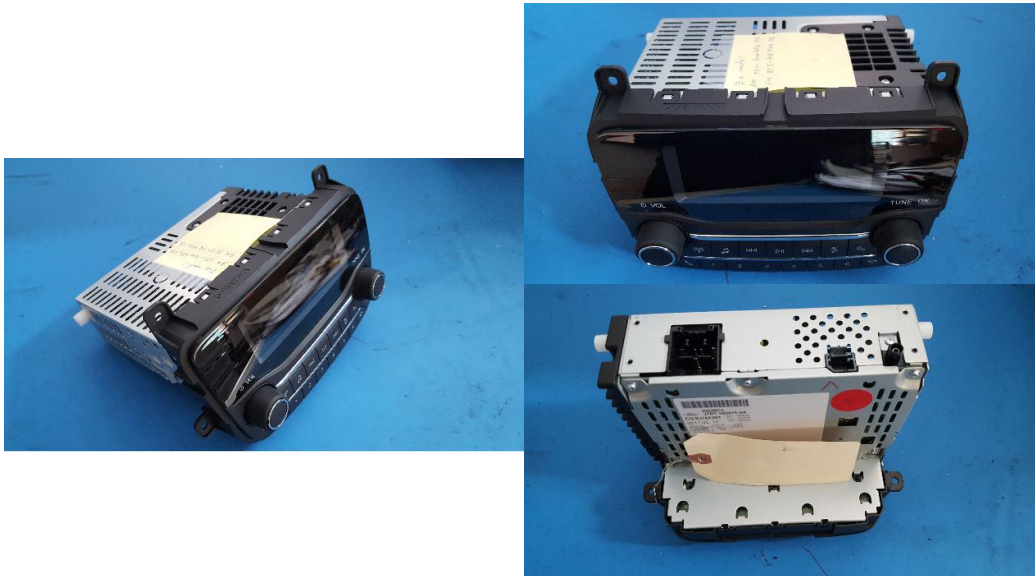

Figure 1: Photos of EUT.

Table 3: EUT Declarations.

General Declarations			
Equipment Type:	Bluetooth Head Unit	Country of Origin:	USA
Nominal Supply:	13.4 VDC	Oper. Temp Range:	-30°C to +70°C
Frequency Range:	2402 – 2480 MHz	Antenna Dimension:	Integral
Antenna Type:	Integral	Antenna Gain:	2.1 dB
Number of Channels:	79	Channel Spacing:	1 MHz
Alignment Range:	Not Declared	Type of Modulation:	GFSK,pi/4-DQPSK,8DPSK
United States			
FCC ID Number:	ACJ-TI114A	Classification:	DSS
Canada			
IC Number:	Not-Declared	Classification:	Spread Spectrum (24002483.5 MHz), Blue- tooth

3.1.1 EUT Configuration

The EUT is configured for testing as depicted in Figure 2.

3.1.2 Modes of Operation

The EUT is capable of operating as a Bluetooth transceiver and as a broadcast (AM/FM) receiver. As a Bluetooth 2.0+EDR device, the EUT is capable of operation as a transceiver employing GFSK, pi/4-DPSK, and 8DPSK

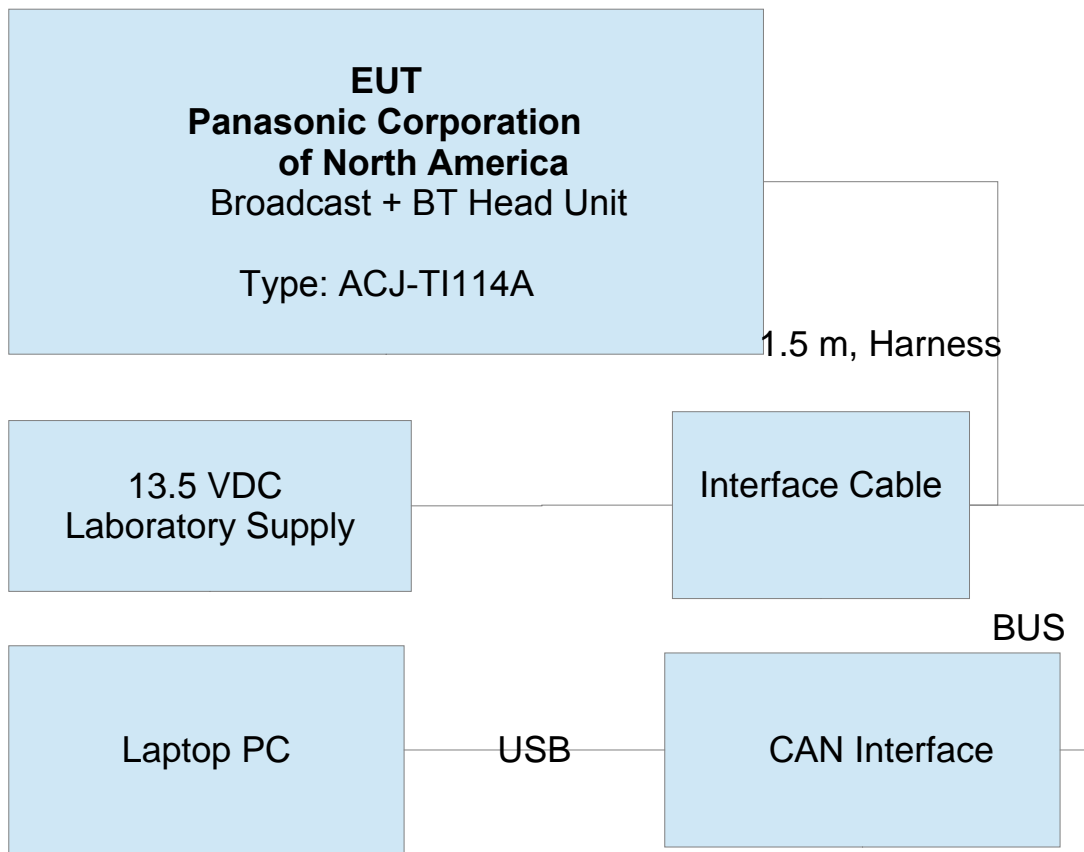

Figure 2: EUT Test Configuration Diagram.

modulations at 1, 2, and 3 Mbps data rates. Test samples were placed into worst-case operating modes using an Agilent N4010A Bluetooth test set. Please note that the different operating modes (data-mode, acquisition-mode) of a Bluetooth device do not influence the channel spacing or peak output power. There is only one transmitter which is driven by identical input parameters concerning these values.

3.1.3 Variants

There is only a single variant of the EUT.

3.1.4 Test Samples

Three samples in total were provided. A normal sample and a sample modified with an RF coaxial cable attached to the Bluetooth radio were provided (both capable of control in BT loopback test mode) and a third unmodified sample for photographs.

3.1.5 Functional Exerciser

Head unit functionality was verified by listening to broadcast audio and connecting the EUT to the N4010A Bluetooth test set. A speakers were attached to the load box on the +LR and +FR speaker terminals.

3.1.6 Modifications Made

There were no modifications made to the EUT by this laboratory.

3.1.7 Production Intent

The EUT appears to be a production ready sample.

3.1.8 Declared Exemptions and Additional Product Notes

The EUT is permanently installed in a transportation vehicle. As such, digital emissions are exempt from US and Canadian digital emissions regulations (per FCC 15.103(a) and IC correspondence on ICES-003).

4 Emissions

4.1 General Test Procedures

4.1.1 Radiated Test Setup and Procedures

Radiated electromagnetic emissions from the EUT are first pre-scanned in our screen room. Spectrum and modulation characteristics of all emissions are recorded. Instrumentation, including spectrum analyzers and other test equipment as detailed in Section 1.8 are employed. After pre-scan, emission measurements are made on the test site of record. If the EUT connects to auxiliary equipment and is table or floor standing, the configurations prescribed in relevant test standards are followed. Alternatively, a layout closest to normal use (as declared by the provider) is employed if the resulting emissions appear to be worst-case in such a configuration. See Figure 3. All intentionally radiating elements that are not fixed-mounted in use are placed on the test table lying flat, on their side, and on their end (3-axes) and the resulting worst case emissions are recorded. If the EUT is fixed-mounted in use, measurements are made with the device oriented in the manner consistent with installation and then emissions are recorded. If the EUT exhibits spurious emissions due to internal receiver circuitry, such emissions are measured with an appropriate carrier signal applied.

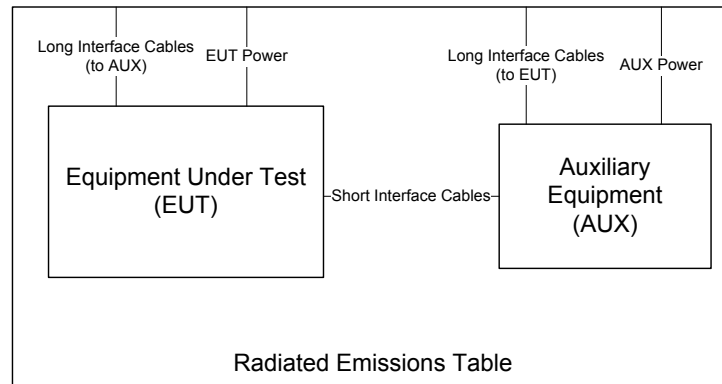

Figure 3: Radiated Emissions Diagram of the EUT.

For devices with intentional emissions below 30 MHz, a shielded loop antenna and/or E-field and H-Field broadband probes are used depending on the regulations. Shielded loops are placed at a 1 meter receive height at the desired measurement distance. For exposure in this band, the broadband probes employed are 10cm diameter single-axis shielded transducers and measurements are repeated and summed over three axes.

Emissions between 30 MHz and 1 GHz are measured using calibrated broadband antennas. For both horizontal and vertical polarizations, the test antenna is raised and lowered from 1 to 4 m in height until a maximum emission level is detected. The EUT is then rotated through 360° in azimuth until the highest emission is detected. The test antenna is then raised and lowered one last time from 1 to 4 m and the worst case value is recorded. Emissions above 1 GHz are characterized using standard gain or broadband ridge-horn antennas on our OATS with a 4×5 m rectangle of ECCOSORB absorber covering the OATS ground screen. Care is taken to ensure that test receiver resolution and video bandwidths meet the regulatory requirements, and that the emission bandwidth of the EUT is not reduced. Photographs of the test setup employed are depicted in Figure 4.

Where regulations allow for direct measurement of field strength, power values (dBm) measured on the test receiver / analyzer are converted to $\text{dB}\mu\text{V}/\text{m}$ at the regulatory distance, using

$$E_{dist} = 107 + P_R + K_A - K_G + K_E - C_F$$

where P_R is the power recorded on spectrum analyzer, in dBm, K_A is the test antenna factor in dB/m, K_G is the combined pre-amplifier gain and cable loss in dB, K_E is duty correction factor (when applicable) in dB, and C_F is a distance conversion (employed only if limits are specified at alternate distance) in dB. This field strength value is then compared with the regulatory limit. If effective isotropic radiated power (EIRP) is computed, it is computed as

$$EIRP(\text{dBm}) = E_{3m}(\text{dB}\mu\text{V}/\text{m}) - 95.2.$$

When presenting data at each frequency, the highest measured emission under all possible EUT orientations (3-axes) is reported.

Where regulations call for substitution method measurements, the EUT is replaced by a substitution antenna if field strength measurements indicate the emission is close to the regulatory limit. This antenna is co-polarized with the test antenna and tuned (when necessary) to the emission frequency, after which the test antenna height is again optimized. The substitution antenna's signal level is adjusted such that its emission is equal to the level measured from the EUT. The signal level applied to the substitution antenna is then recorded. Effective isotropic radiated power (EIRP) and effective radiated power (ERP) in dBm are formulated from

$$EIRP = P_T - G_A = ERP + 2.16, \quad (1)$$

where P_T is the power applied to substitution antenna in dBm, including correction for cable loss, and G_A is the substitution antenna gain, in dBi.

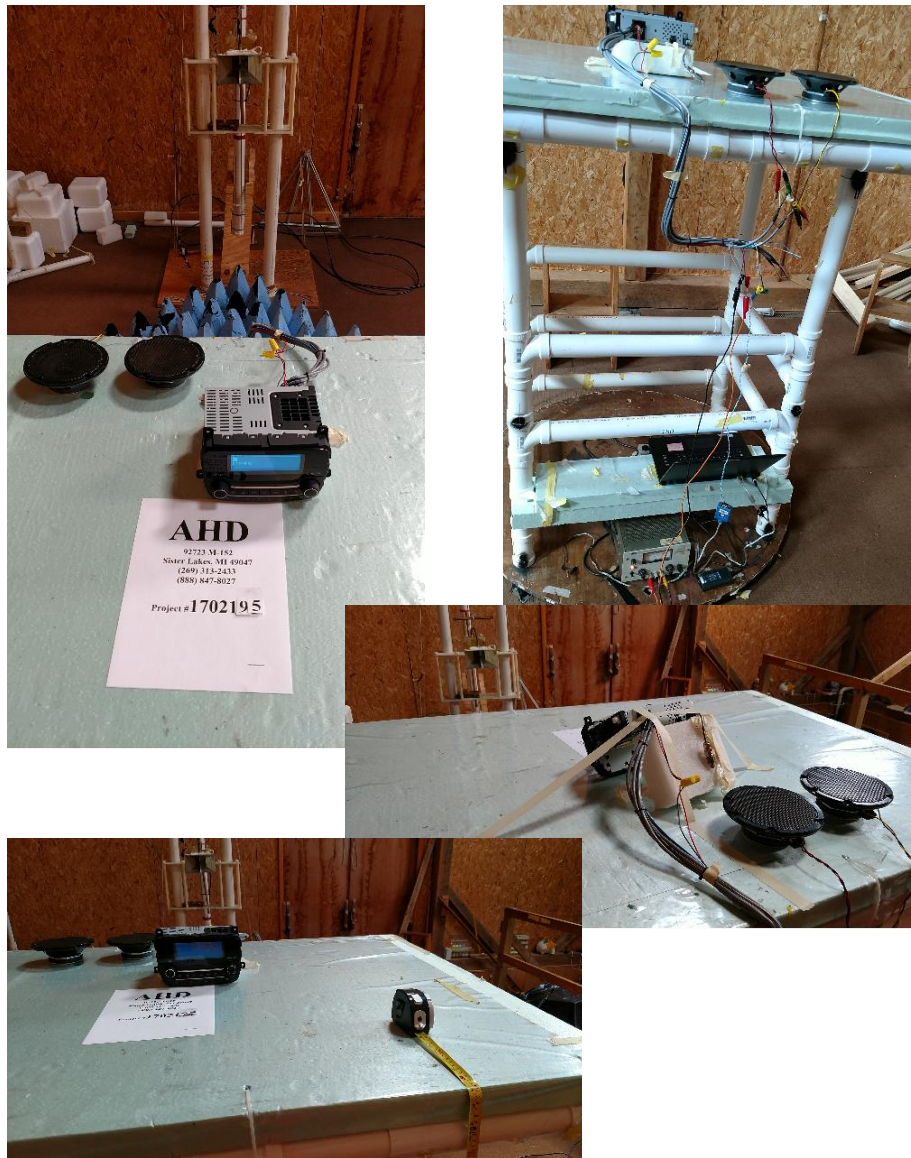

Figure 4: Radiated Emissions Test Setup Photograph(s).

4.1.2 Conducted Emissions Test Setup and Procedures

Transmit Antenna Port Conducted Emissions At least one sample EUT supplied for testing was provided with a 50Ω antenna port. Conducted transmit chain emissions measurements (where applicable) are made by connecting the EUT antenna port directly to the test receiver port. Photographs of the test setup employed are depicted in Figure 5.

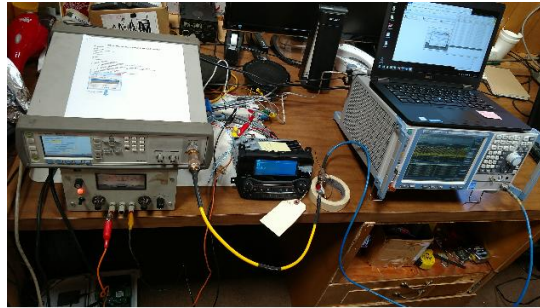

Figure 5: Conducted RF Test Setup Photograph(s).

4.1.3 Power Supply Variation

Tests at extreme supply voltages are made if required by the the procedures specified in the test standard, and results of this testing are detailed in this report.

4.2 Intentional Emissions

4.2.1 Duty and Transmission Cycle, Pulsed Operation

The details and results of testing the EUT for pulsed operation are summarized in Table 4.

Table 4: Pulsed Emission Characteristics (Duty Cycle).

Frequency Range f > 1 000 MHz	Det Pk	IFBW 3 MHz	VBW 5 MHz	Test Date: 28-Sep-17
				Test Engineer: Gordon Helm
				EUT: Panasonic BT Tuner
				Meas. Distance: Conducted

Pulsed Operation / Duty Cycle								
Transmit Mode	Symbol Rate (Msym/s)	Data Rate (Mbps)	Voltage (V)	Oper. Freq (MHz)	Tx Cycle Time* (ms)	On-Time* (ms)	Duty Cycle (%)	Power Duty Correction (dB)
Hopping	1.000	GFSK (1 Mbps)	13.4	2441.0	-	-	-	-
	1.000	Pi/4 DPSK (2 Mbps)	13.4	2441.0	-	-	-	-
	1.000	8DPSK (3 Mbps)	13.4	2441.0	-	-	-	-

(1) For a Bluetooth transmitter the peak to average ratio in any given 100 ms window is always less than 10%. Thus, maximum permitted 15.35 duty of 20 dB may be applied to peak measurements for demonstrating average field strength compliance, were applicable. However, no duty cycle is applied herein for demonstrating compliance.

4.2.2 Hopping Channel Dwell Time

The average time of occupancy on any hopping channel must not be greater than 0.4 seconds within a 20 second period for FHSS device with 50 operating channels. For this test, the EUT was set for data transmission with hopping enabled. Results of this testing are depicted in Table 5. Plots showing example measurements made

Table 5: Hopping Channel Dwell Time.

Frequency Range 25 MHz f 1 000 MHz f > 1 000 MHz	Det Pk/QPk Pk	IF Bandwidth 100/120 kHz 3 MHz	Video Bandwidth 300 kHz 3 MHz	Test Date: 28-Sep-17
				Test Engineer: Joseph Brunett
				EUT: Panasonic BT Tuner
				Meas. Distance: Conducted

Dwell Time								
Packet Type	Frequency (MHz)	# Bursts #	Observation Time (sec)	Window (sec)	Active Time (sec)	Total On Time** (s)	Limit (s)	Pass/Fail
DH1 (min)	2441.0	97	32.0	32.0	0.00046	0.0441	<0.4	Pass
DH5 (max)	2441.0	60	32.0	32.0	0.00296	0.1776	<0.4	Pass

* Dwell Time Observed with EUT placed into self-test hopping mode via PC interface.

**The measured dwell time may not indicate the actual single channel dwell time of the DUT. A dwell time of 0.3797 seconds in data mode is independent from the packet type (packet length) for all Bluetooth devices. Therefore, Bluetooth devices comply with the dwell time requirement.

to obtain these values are provided in Figure 6.

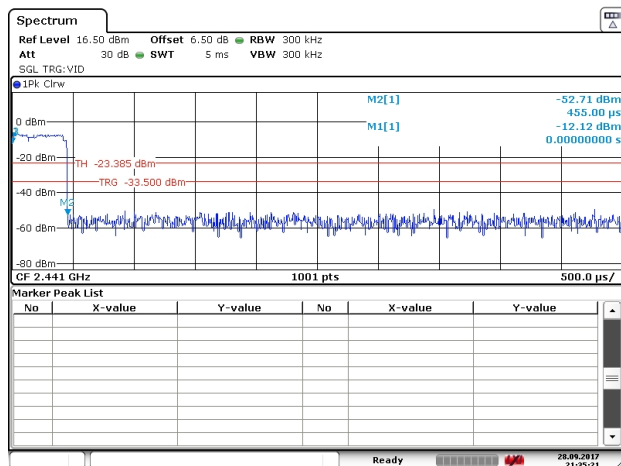
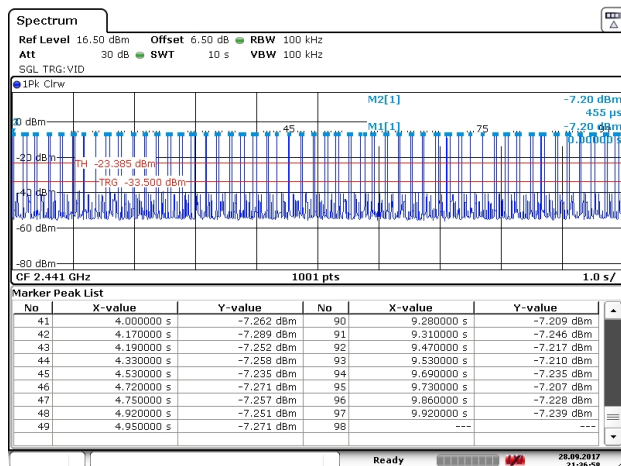
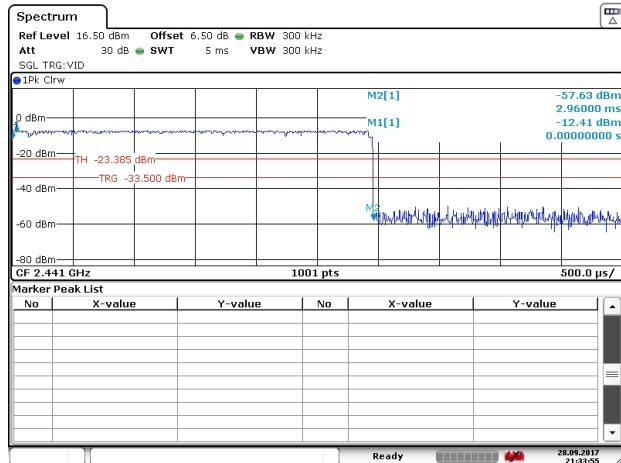
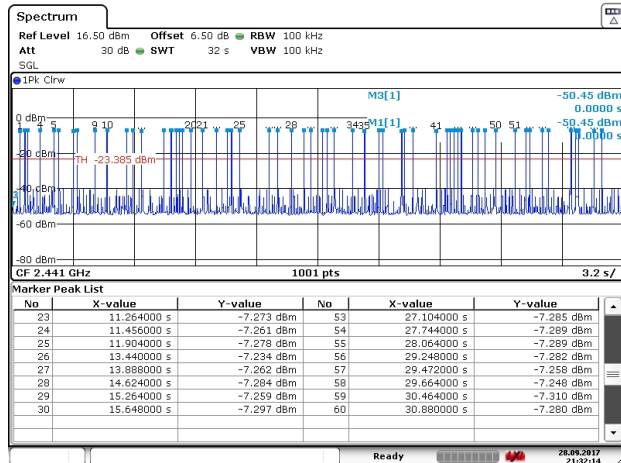

Figure 6: Example Plots of Duty Cycle and Channel Dwell Time.

4.2.3 Channel Bandwidth

For this test, the EUT was set continuous data transmission (hopping disabled) in each modulation. The 20-dB bandwidth as well as 99% emission bandwidth were measured for the low, middle, and high channels. Results of these measurements are shown in Table 6. Plots showing example measurements employed to obtain this data are provided in Figure 8.

Table 6: Intentional Emission Bandwidth.

Frequency Range	Det	IFBW	VBW	Test Date:	09/28/17
f > 1 000 MHz	Pk	30 kHz	100 kHz	Test Engineer:	Joseph Brunett
f > 1 000 MHz	Pk	30 kHz	100 kHz	EUT	Panasonic BT Tuner
				Meas. Distance:	Conducted

Occupied Bandwidth									
Transmit Mode	Symbol Rate (Msym/s)	Data Rate* (Mbps)	Voltage (V)	Oper. Freq (MHz)	6 dB BW (MHz)	6 dB BW Limit (MHz)	99% OBW (MHz)	20 dB BW (MHz)	Pass/Fail
GFSK	1	1.0	13.4	2402.0	-	-	0.825	0.864	Pass
				2441.0	-	-	0.843	0.933	Pass
				2480.0	-	-	0.832	0.864	Pass
PI/4 DQPSK	1	2.0	13.4	2402.0	-	-	1.165	1.237	Pass
				2441.0	-	-	1.165	1.276	Pass
				2480.0	-	-	1.165	1.271	Pass
8QPSK	1	3.0	13.4	2402.0	-	-	1.162	1.228	Pass
				2441.0	-	-	1.165	1.276	Pass
				2480.0	-	-	1.163	1.265	Pass

* Over all modes of operation, the worst case (highest data rate) in each form of modulation was tested to demonstrate compliance. For GFSK, worst test pattern employed F0F0 dataset, for pi/4-DQPSK the PN15 dataset, for 8-DQPSK the PN15 dataset.

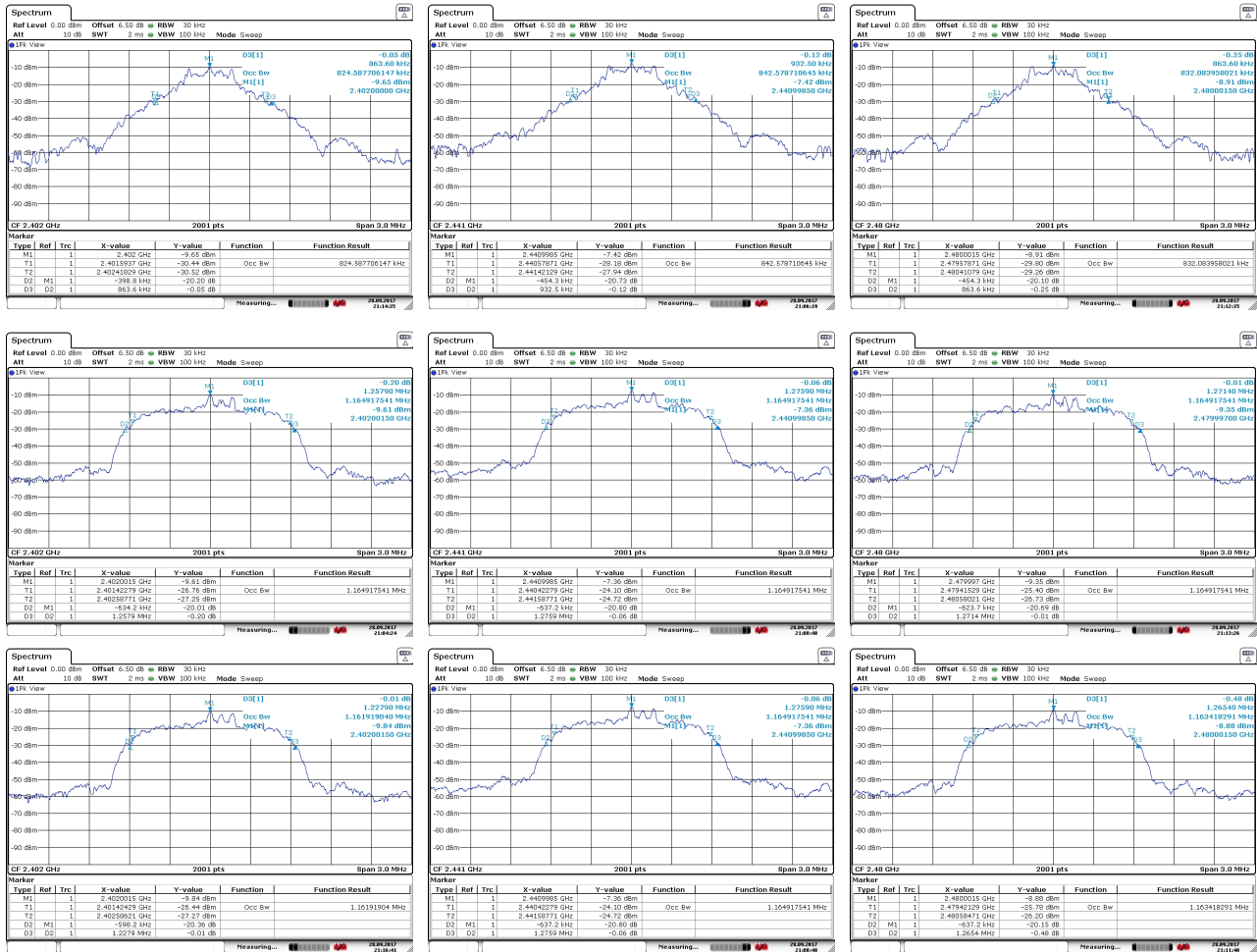

Figure 7: Intentional Emission Bandwidth.

4.2.4 Number of Hopping Channels

For this test, the EUT was enabled for data transmission with hopping. The number of channels measured is reported here in Table 7.

Table 7: Measured Number of Hopping Channels.

Frequency Range	Det	IF Bandwidth	Video Bandwidth	Test Date:	28-Sep-17
25 MHz f 1 000 MHz	Pk/QPk	100/120 kHz	300 kHz	Test Engineer:	Joseph Brunett
f > 1 000 MHz	Pk	100 kHz	3 MHz	EUT:	Panasonic BT Tuner
				Meas. Distance:	Conducted

Number of Hopping Channels						
Mode	Start Frequency (MHz)	Stop Frequency (MHz)	Number of Channels Observed (#)	Total Number (#)	Limit (#)	Pass/Fail
GFSK Hopping	2400.0	2483.5	79	79	15.0	Pass

4.2.5 Channel Separation

For this test, the EUT was enabled for data transmission with hopping. The Carrier Separation was measured for low, mid, and high channels. Results of these measurements are shown in Table 8.

Table 8: Measured Channel Separation.

Frequency Range	Det	IF Bandwidth	Video Bandwidth	Test Date:	28-Sep-17
25 MHz f 1 000 MHz	Pk/QPk	100/120 kHz	300 kHz	Test Engineer:	Joseph Brunett
f > 1 000 MHz	Pk	100 kHz	3 MHz	EUT:	Panasonic BT Tuner
				Meas. Distance:	Conducted

Hopping Frequency Separation					
Mode	Low Channel Frequency (MHz)	High Channel Frequency (MHz)	Separation (MHz)	Separation Limit (kHz)	Pass/Fail
GFSK	2402.0	2403.0	1.001	>840	Pass
	2441.0	2442.0	1.003	>840	Pass
	2479.0	2480.0	1.004	>840	Pass
Pi/4DQPSK	Channel Separation is the same for all modulations in a Bluetooth transceiver. Only worst-case GFSK modulation was tested to demonstrate compliance.				
8DQPSK					

* Channel Separation Observed with the Device hopping over all available channels.

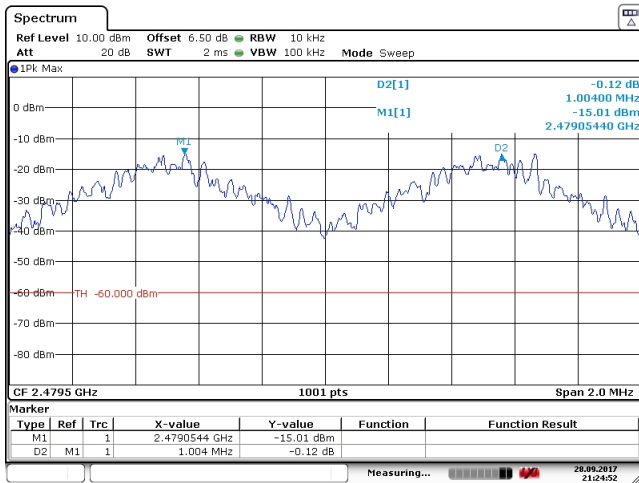
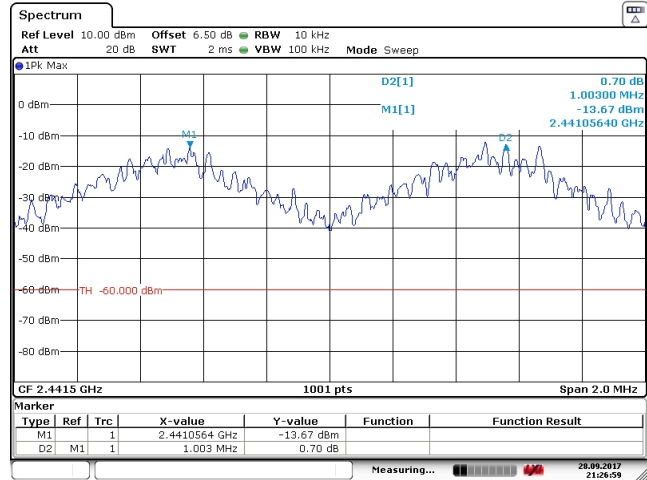
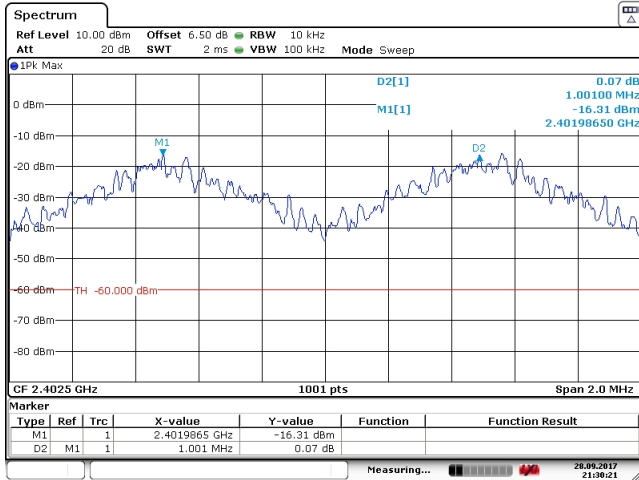

Figure 8: Measured Channel Separation.

4.2.6 Effective Isotropic Radiated Power

The EUT’s radiated power is computed from antenna port conducted power measurements and the gain of the EUT antenna(s). Where the EUT is not sold with an antenna connector, a modified product has been provided including such. Peak conducted output power was measured directly from the EUT at the port where the antenna attaches. The test receiver bandwidth was set to be greater than the measured emission bandwidth of the EUT to capture the true peak. Antenna gain is either provided directly by the antenna manufacturer or measured by comparison between calculated EIRP and conducted output power. Table 9 details the results of these measurements. Plots showing conducted measurements made are depicted in Figure 9.

Table 9: Radiated Power Results.

Frequency Range	Det	IF Bandwidth	Video Bandwidth	Test Date:	28-Sep-17
25 MHz f 1 000 MHz	Pk/QPk	120 kHz	300 kHz	Test Engineer:	Gordon Helm
f > 1 000 MHz	Pk/Avg	3 MHz	3 MHz	EUT:	Panasonic BT Tuner
				Meas. Distance:	3m

FCC/IC

#	Mode	Channel	Freq. MHz	Ant. Used	Ant. Pol.	Table Azim. deg	Ant Height m	Ka dB/m	Kg dB	E3(Pk) dBµV/m	EIRP (Pk) dBm	Pout* (Pk) dBm	Ant Gain dBi	EIRP (Avg) Limit dBm	Pass dB
1	CW	L	2402.0	RH3115	H/V	.0	1.3	28.9	-2.3	85.7	-9.5	-10.8	1.3	30.0	39.5
2		M	2441.0	RH3115	H/V	.0	1.3	29.0	-2.4	86.2	-9.0	-8.0	-1.0	30.0	39.0
3		H	2480.0	RH3115	H/V	.0	1.3	29.1	-2.4	84.9	-10.3	-9.5	-0.8	30.0	40.3
4															
#	Mode	Channel	Freq. MHz	Supply Voltage	Ant. Pol.	Table Azim. deg	Ant Height m	Ka dB/m	Kg dB	EIRP (Pk) dBm					
5	CW	M	2441.0	18.0	H/V	rel	rel	29.0	-2.4	84.3					
6			2441.0	15.0	H/V	rel	rel	29.0	-2.4	84.3					
7			2441.0	13.4	H/V	.0	1.3	29.0	-2.4	84.3					
8			2441.0	9.0	H/V	rel	rel	29.0	-2.4	84.3					
9															

* Measured conducted from the radio using conducted test sample.

** Measured radiated at 3 meter distance. Peak power measured with IFBW > OBW per DTS Procedures 9.1.1 RBW > DTS bandwidth

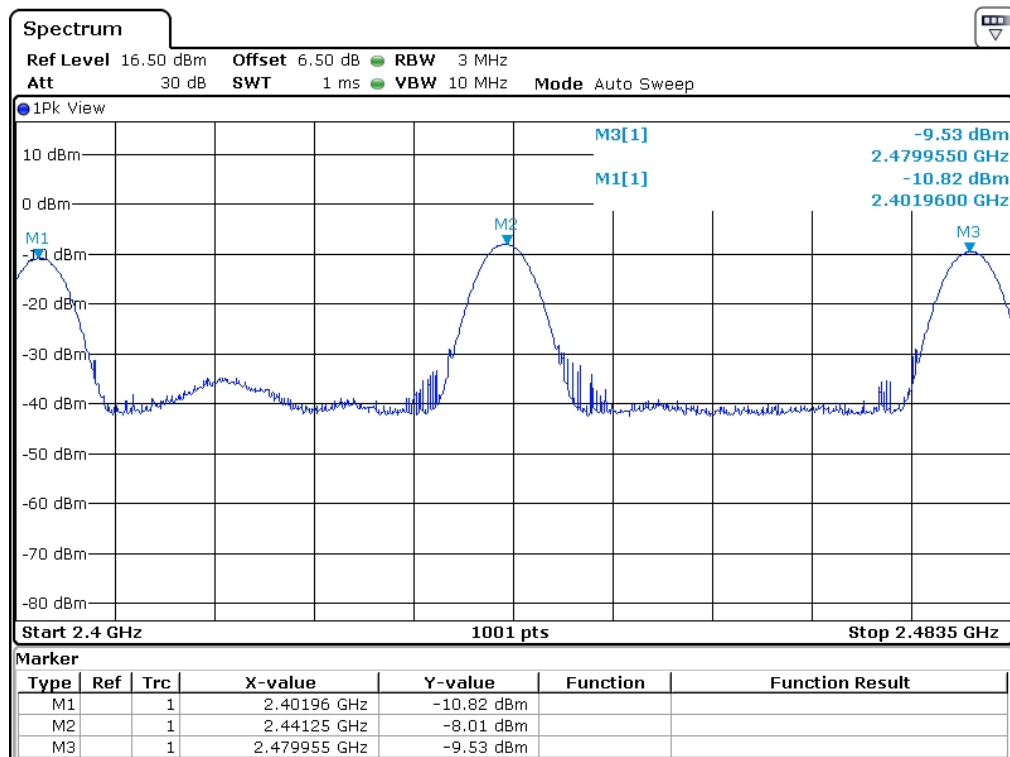

Figure 9: Conducted RF Power Plots

4.3 Unintentional Emissions

4.3.1 Transmit Chain Spurious Emissions

The results for the measurement of transmit chain spurious emissions at the nominal voltage and temperature are provided in Table 10. Measurements are performed to 10 times the highest fundamental operating frequency.

Table 10: Transmit Chain Spurious Emissions.

Frequency Range	Det	IF Bandwidth	Video Bandwidth	Test Date:	28-Sep-17
25 MHz f 1 000 MHz	Pk/QPk	120 kHz	300 kHz	Test Engineer:	Gordon Helm
f > 1 000 MHz	Pk/Avg	1 MHz	3 MHz	EUT:	Panasonic BT Tuner
				Mode:	Modulated (all modes)
				Meas. Distance:	3m

														FCC/IC
#	Freq. Start MHz	Freq. Stop MHz	Ant. Used	Ant. Pol.	Table Azim. deg	Ant Height m	Ka dB/m	Kg dB	E3(Pk) dBµV/m	E3 Pk Lim dBµV/m	E3(Avg) dBµV/m	E3 Avg Lim dBµV/m	Pass dB	Comments
1	Fundamental Restricted Band Edge (Low Side)													
2	2390.0	2390.0	RH3115	H/V	0	1.2	28.9	-2.3	53.8	74.0	45.5	54.0	8.5	all channels; max all modulations; noise
3	Fundamental Restricted Band Edge (High Side)													
4	2483.5	2483.5	RH3115	H/V	0	1.2	29.1	-2.4	56.8	74.0	44.4	54.0	9.6	all channels; max all modulations; noise
5	Harmonic / Spurious Emissions													
6	4804.0	4804.0	RH3115	H/V	0	1.3	33.1	-3.5	23.7	74.0		54.0	30.3	max all, noise
7	4882.0	4805.0	RH3115	H/V	0	1.3	33.1	-3.6	23.3	74.0		54.0	30.7	max all, noise
8	4960.0	4806.0	RH3115	H/V	0	1.3	33.1	-3.6	22.2	74.0		54.0	31.8	max all, noise
9	4000.0	6000.0	RH3115	H/V	0	1.3	35.0	-3.1	23.7	74.0		54.0	30.3	all channels; max all modulations
10	7206.0	7206.0	RH3115	H/V	0	1.3	36.7	-4.5	43.7	74.0		54.0	10.3	max all
11	7323.0	7323.0	RH3115	H/V	0	1.2	36.9	-4.6	43.8	74.0		54.0	10.2	max all
12	7440.0	7440.0	RH3115	H/V	0	1.2	37.0	-4.6	43.9	74.0		54.0	10.1	max all
13	6000.0	8400.0	RH3115	H/V	0	1.3	37.6	-4.1	43.9	74.0		54.0	10.1	all channels; max all modulations
14	8400.0	12500.0	RH3115	H/V	0	1.2	40.5	-4.9	41.5	74.0		54.0	12.5	all channels; max all modulations; noise
15	12500.0	18000.0	RH3115	H/V	0	1.2	45.2	-6.1	35.3	74.0		54.0	18.7	all channels; max all modulations; noise
16	18000.0	26000.0	RHCOB1840	H/V	0	1.2	53.0	-7.4	33.9	74.0		54.0	20.1	all channels; max all modulations; noise
17														
18														

*Avg measurements made employing average detector.

4.3.2 Relative Transmit Chain Spurious Emissions

The results for the measurement of transmit chain spurious emissions relative to the fundamental in a 100 kHz receiver bandwidth (at the nominal voltage and temperature) are provided in Figure 10 below.

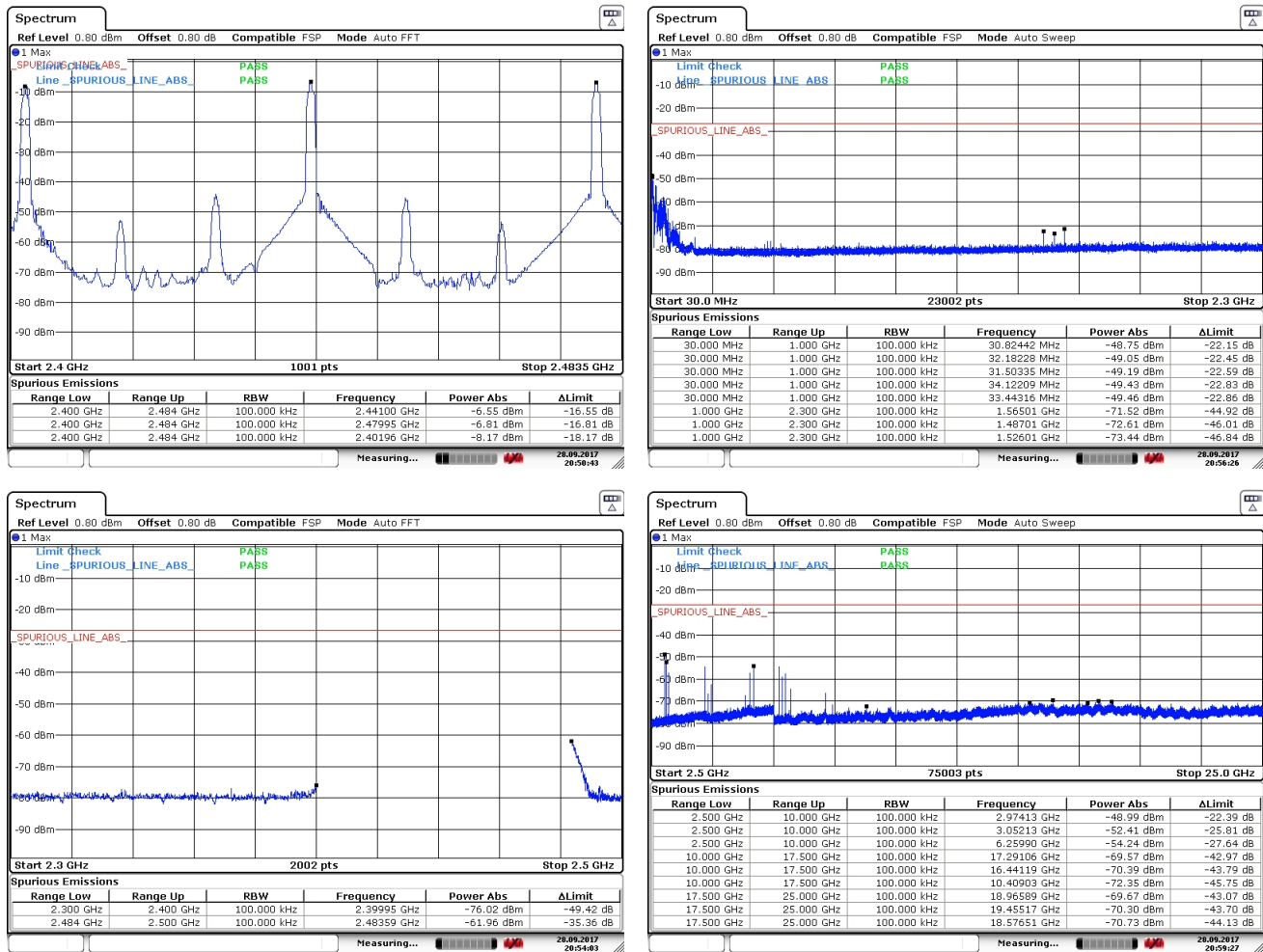

Figure 10: Conducted Transmitter Emissions Measured.

5 Measurement Uncertainty and Accreditation Documents

The maximum values of measurement uncertainty for the laboratory test equipment and facilities associated with each test are given in the table below. This uncertainty is computed for a 95.45% confidence level based on a coverage factor of $k = 2$.

Table 11: Measurement Uncertainty.

Measured Parameter	Measurement Uncertainty [†]
Radio Frequency	$\pm(f_{Mkr}/10^7 + RBW/10 + (SPN/(PTS - 1)))/2 + 1 \text{ Hz}$
Conducted Emm. Amplitude	$\pm 1.9 \text{ dB}$
Radiated Emm. Amplitude (30 – 200 MHz)	$\pm 4.0 \text{ dB}$
Radiated Emm. Amplitude (200 – 1000 MHz)	$\pm 5.2 \text{ dB}$
Radiated Emm. Amplitude ($f > 1000 \text{ MHz}$)	$\pm 3.7 \text{ dB}$

[†]Ref: CISPR 16-4-2:2011+A1:2014

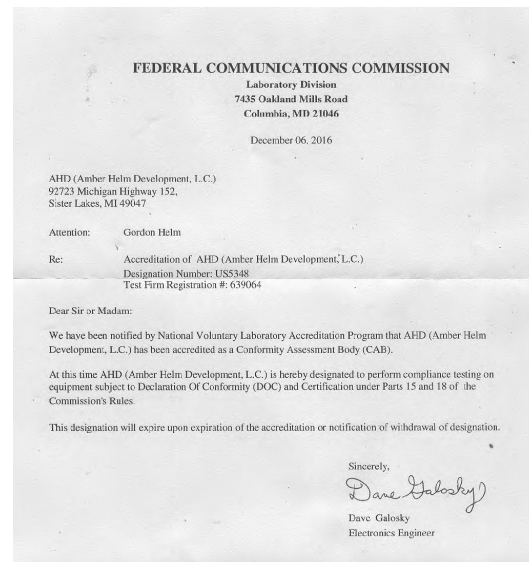

Figure 11: Accreditation Documents