



RADIO TEST REPORT

Test Report No. : 29GE0129-HO-01-C

Applicant : Panasonic Corporation
Type of Equipment : Home theater audio system
(Wireless Audio Transmitter)
Model No. : Amp: SU-ZT1
FCC ID : ACJ-SU-ZT1
Test regulation : FCC Part 15 Subpart C 2009
Section 15.207, Section 15.247
Test Result : Complied

1. This test report shall not be reproduced in full or partial, without the written approval of UL Japan, Inc.
2. The results in this report apply only to the sample tested.
3. This sample tested is in compliance with the above regulation.
4. The test results in this report are traceable to the national or international standards.
5. This test report must not be used by the customer to claim product certification, approval, or endorsement by NVLAP, NIST, or any agency of the Federal Government.

Date of test: March 23 to April 7, 2009

Tested by:

M. Imura

Motoya Imura
EMC Services

T. Choda

Takeshi Choda
EMC Services

K. Kawamura

Keisuke Kawamura
EMC Services

K. Okai

Katsunori Okai
EMC Services

T. Nakagawa

Tomohisa Nakagawa
EMC Services

Approved by :

M. Fujimura

Mitsuru Fujimura
Assistant Manager
of EMC Services



NVLAP LAB CODE: 200572-0

This laboratory is accredited by the NVLAP LAB CODE 200572-0, U.S.A. The tests reported herein have been performed in accordance with its terms of accreditation.
*As for the range of Accreditation in NVLAP, you may refer to the WEB address, <http://uljapan.co.jp/emc/nvlap.html>

UL Japan, Inc.

Head Office EMC Lab.

4383-326 Asama-cho, Ise-shi, Mie-ken 516-0021 JAPAN

Telephone : +81 596 24 8116

Facsimile : +81 596 24 8124

MF060b (09.01.08)

CONTENTS	PAGE
SECTION 1: Customer information.....	3
SECTION 2: Equipment under test (E.U.T.).....	3
SECTION 3: Test specification, procedures & results.....	4
SECTION 4: Operation of E.U.T. during testing.....	8
SECTION 5: Conducted Emission.....	10
SECTION 6: Spurious Emission.....	11
SECTION 7: Bandwidth.....	12
SECTION 8: Maximum Peak Output Power.....	13
SECTION 9: Peak Power Density.....	13
APPENDIX 1: Photographs of test setup.....	14
Conducted Emission.....	14
Spurious Emission (Radiated).....	15
APPENDIX 2: Data of EMI test.....	16
Conducted Emission.....	16
6dB Bandwidth.....	20
Maximum Peak Output Power.....	22
Radiated Spurious Emission (below 1GHz).....	24
Radiated Spurious Emission (above 1GHz).....	28
Conducted Spurious Emission.....	32
Conducted emission Band Edge compliance.....	36
Power Density.....	37
99%Occupied Bandwidth.....	39
APPENDIX 3: Test instruments.....	40

SECTION 1: Customer information

Company Name : Panasonic Corporation
Address : 1-15 Matsuo-cho, Kadoma City, Osaka, 571-8504 Japan
Telephone Number : +81-6-6905-4970
Facsimile Number : +81-6-6906-8800
Contact Person : Hiroshi Hamanaka

SECTION 2: Equipment under test (E.U.T.)

2.1 Identification of E.U.T.

Type of Equipment : Home theater audio system (Wireless Audio Transmitter)
Model No. : Amp: SU-ZT1
Serial No. : 001, 002
Power supply : AC120V/220-240V
Receipt Date of Sample : March 15, 2009
Country of Mass-production : Malaysia
Condition of EUT : Production prototype
(Not for Sale: This sample is equivalent to mass-produced items.)
Modification of EUT : No Modification by the test lab

2.2 Product Description

Model No: Amp: SU-ZT1 (referred to as the EUT in this report) is the Home theater audio system (Wireless Audio Transmitter).

Feature of EUT:

Amp: SU-ZT1: Wireless Audio Transmitter

Clock frequency(ies) in the system : Wireless card: 16MHz(CPU), 24.576MHz(ADC)
10MHz(Main CPU), 24.576MHz(DSP), 28.322MHz(HDMI RX),
4MHz(HDMI CPU, Remote unit)

[Amp part]

Equipment Type : Transceiver
Frequency of Operation : 2412, 2438, 2462MHz (3ch)
Bandwidth : 16MHz
Type of Modulation : OFDM
Antenna Type : PIFA
Antenna Gain : 1.5dBi
Operating Voltage (inner) : DC3.3V
Method of Frequency generation : synthesizer method by crystal oscillator

UL Japan, Inc.

Head Office EMC Lab.

4383-326 Asama-cho, Ise-shi, Mie-ken 516-0021 JAPAN

Telephone : +81 596 24 8116

Facsimile : +81 596 24 8124

SECTION 3: Test specification, procedures & results

3.1 Test Specification

Test Specification : FCC Part15 Subpart C: 2009, final revised on February 27, 2009

Title : FCC 47CFR Part15 Radio Frequency Devices Subpart C Intentional Radiators
Section 15.207 Conducted limits
Section 15.247 Operation within the bands 902-928MHz,
2400-2483.5MHz, and 5725-5850MHz

The EUT complies with FCC Part 15 Subpart B/ICES-003. Refer to the test report No.29GE0129-HO-01-A.

FCC 15.31 (e)

This EUT provides stable voltage(DC3.3V) constantly to RF Part regardless of input voltage. Therefore, this EUT complies with the requirement.

FCC Part 15.203 Antenna requirement

It is impossible for end users to replace the antenna, because the antenna is mounted inside of the EUT. Therefore, the equipment complies with the antenna requirement of Section 15.203.

3.2 Procedures and results

[DSSS and other forms of modulation]

No.	Item	Test Procedure	Specification	Remarks	Deviation	Worst margin	Results
1	Conducted emission	FCC: ANSI C63.4:2003 7. AC powerline conducted emission measurements ----- IC: RSS-Gen 7.2.2	FCC: Section 15.207 ----- IC: RSS-Gen 7.2.2	Conducted	N/A	[Tx] QP 14.8dB 21.40600MHz, L AV 17.8dB 1.31352MHz, L [Rx] QP 16.1dB 21.72172MHz, L AV 17.5dB 0.91353MHz, L	Complied
2	6dB Bandwidth	FCC: "Guidance on Measurement of Digital Transmission Systems Operating under Section15.247" ----- IC: RSS-Gen 4.6.2	FCC: Section 15.247(a)(2) ----- IC: RSS-210 A8.2(a)	Conducted	N/A	See data.	Complied
3	Maximum Peak Output Power	FCC: "Guidance on Measurement of Digital Transmission Systems Operating under Section15.247" ----- IC: RSS-Gen 4.8	FCC: Section 15.247(b)(3) ----- IC: RSS-210 A8.4(4)	Conducted	N/A		Complied
4	Restricted Band Edges	FCC: "Guidance on Measurement of Digital Transmission Systems Operating under Section15.247" ----- IC: -	FCC: Section 15.247 (d) ----- IC: RSS-210 A8.5	Conducted/ Radiated	N/A		Complied
5	Power Density	FCC: "Guidance on Measurement of Digital Transmission Systems Operating under Section15.247" ----- IC: -	FCC: Section 15.247 (e) ----- IC: RSS-210 A8.2(b)	Conducted	N/A		Complied
6	Spurious Emission	FCC: "Guidance on Measurement of Digital Transmission Systems Operating under Section15.247" ----- IC: RSS-Gen 4.9 RSS-Gen 4.10	FCC: Section15.247(d) ----- IC: RSS-210 A8.5 RSS-Gen 7.2.1 and 7.2.3	Conducted/ Radiated	N/A	[Tx] 3.6dB 466.818MHz, QP, Horizontal [Rx] 3.5dB 1105.64MHz, AV Vertical	Complied

Note: UL Japan, Inc.'s EMI Work Procedures No.QPM05 and QPM15.

* In case any questions arise about test procedure, ANSI C63.4: 2003 is also referred.

UL Japan, Inc.

Head Office EMC Lab.

4383-326 Asama-cho, Ise-shi, Mie-ken 516-0021 JAPAN

Telephone : +81 596 24 8116

Facsimile : +81 596 24 8124

3.3 Addition to standard

No.	Item	Test Procedure	Specification	Remarks	Deviation	Worst margin	Results
1	99% Occupied Band Width	RSS-Gen 4.6.1	RSS-Gen 4.6.1	Radiated	N/A	N/A	N/A

Other than above, no addition, exclusion nor deviation has been made from the standard.

3.4 Uncertainty

EMI

The following uncertainties have been calculated to provide a confidence level of 95% using a coverage factor k=2.

Test room	Conducted emission	Radiated emission (10m*)			Radiated emission (3m*)			Radiated emission (3m*)	
	150kHz-30MHz	9kHz-30MHz	30MHz-300MHz	300MHz-1GHz	9kHz-30MHz	30MHz-300MHz	300MHz-1GHz	1GHz-18GHz	18GHz-40GHz
No.1 semi-anechoic chamber (±)	3.7dB	3.1dB	4.4dB	4.2dB	3.2dB	3.8dB	3.9dB	5.9dB	6.1dB
No.2 semi-anechoic chamber (±)	3.7dB	-	-	-	3.2dB	4.4dB	4.0dB	5.9dB	6.1dB
No.3 semi-anechoic chamber (±)	3.7dB	-	-	-	3.2dB	4.6dB	4.0dB	5.9dB	6.1dB
No.4 semi-anechoic chamber (±)	3.7dB	-	-	-	3.2dB	3.9dB	3.9dB	5.9dB	6.1dB

*10m/3m = Measurement distance

Conducted emission test

The data listed in this test report has enough margin, more than the site margin. [Tx]/[Rx]

Radiated emission test(3m)

The data listed in this report meets the limits unless the uncertainty is taken into consideration. [Tx]/[Rx]

Other test except Conducted Emission and Spurious Emission (Radiated)

The measurement uncertainty for this test is 3.0dB.

UL Japan, Inc.

Head Office EMC Lab.

4383-326 Asama-cho, Ise-shi, Mie-ken 516-0021 JAPAN

Telephone : +81 596 24 8116

Facsimile : +81 596 24 8124

3.5 Test Location

UL Japan, Inc. Head Office EMC Lab. *NVLAP Lab. code: 200572-0
4383-326 Asama-cho, Ise-shi, Mie-ken 516-0021 JAPAN
Telephone : +81 596 24 8116 Facsimile : +81 596 24 8124

	FCC Registration Number	IC Registration Number	Width x Depth x Height (m)	Size of reference ground plane (m) / horizontal conducting plane	Other rooms
No.1 semi-anechoic chamber	313583	2973C-1	19.2 x 11.2 x 7.7m	7.0 x 6.0m	No.1 Power source room
No.2 semi-anechoic chamber	655103	2973C-2	7.5 x 5.8 x 5.2m	4.0 x 4.0m	-
No.3 semi-anechoic chamber	148738	2973C-3	12.0 x 8.5 x 5.9m	6.8 x 5.75m	No.3 Preparation room
No.3 shielded room	-	-	4.0 x 6.0 x 2.7m	N/A	-
No.4 semi-anechoic chamber	134570	2973C-4	12.0 x 8.5 x 5.9m	6.8 x 5.75m	No.4 Preparation room
No.4 shielded room	-	-	4.0 x 6.0 x 2.7m	N/A	-
No.5 semi-anechoic chamber	-	-	6.0 x 6.0 x 3.9m	6.0 x 6.0m	-
No.6 shielded room	-	-	4.0 x 4.5 x 2.7m	4.75 x 5.4 m	-
No.6 measurement room	-	-	4.75 x 5.4 x 3.0m	4.75 x 4.15 m	-
No.7 shielded room	-	-	4.7 x 7.5 x 2.7m	4.7 x 7.5m	-
No.8 measurement room	-	-	3.1 x 5.0 x 2.7m	N/A	-
No.9 measurement room	-	-	8.0 x 4.5 x 2.8m	2.0 x 2.0m	-
No.10 measurement room	-	-	2.6 x 2.8 x 2.5m	2.4 x 2.4m	-
No.11 measurement room	-	-	3.1 x 3.4 x 3.0m	2.4 x 3.4m	-

* Size of vertical conducting plane (for Conducted Emission test) : 2.0 x 2.0m for No.1, No.2, No.3, and No.4 semi-anechoic chambers and No.3 and No.4 shielded rooms.

3.6 Test set up, Data of EMI, and Test instruments

Refer to APPENDIX 1 to 3.

SECTION 4: Operation of E.U.T. during testing

4.1 Operating Mode(s)

Test Item	Operating Mode	Tested frequency
Conducted emission Spurious Emission	Transmitting (Tx), ANT 1	2412MHz(L) 2438MHz(M) 2462MHz(H)
	Receiving (Rx) ANT 1	2438MHz(M)
6dB Bandwidth Maximum Peak Output Power Power Density 99% Occupied Bandwidth	Transmitting (Tx), ANT 1	2412MHz(L) 2438MHz(M) 2462MHz(H)
Restricted Band Edge	Transmitting (Tx), ANT 1	2412MHz(L) 2462MHz(H)
*Transmitting duty was 100% on all tests. *Transmitting mode: EUT continuously transmits the random data of 200,000 bit.		

4.2 Configuration and peripherals

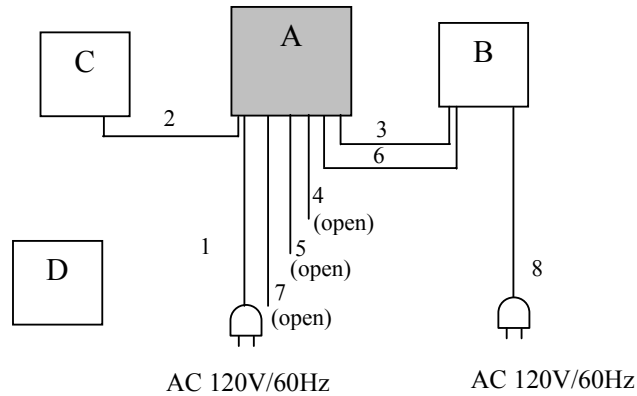

*Cabling and setup were taken into consideration and test data was taken under worst case conditions.

Description of EUT and Support equipment

No.	Item	Model number	Serial number	Manufacturer	Remark
A	Home theater audio system (Wireless Audio Transmitter)	Amp: SU-ZT1	001 *1) 002 *2)	Panasonic	EUT
B	DVD Player	DV-600AV-S	HEKD013328LS	Pioneer	-
C	Portable CD Player	N2897-H1	WL7GA00317R	Panasonic	-
D	Remote Controller	-	90209A	Panasonic	-

*1) Used for Conducted /Radiated emission tests

*2) Used for Antenna Terminal tests

List of cables used

No.	Name	Length (m)	Shield		Remark
			Cable	Connector	
1	AC Cable	1.7	Unshielded	Unshielded	-
2	Audio Cable	1.6	Unshielded	Unshielded	-
3	HDMI Cable	2.0	Shielded	Shielded	-
4	HDMI Cable	2.0	Shielded	Shielded	-
5	HDMI Cable	2.0	Shielded	Shielded	-
6	Audio Cable	3.0	Shielded	Shielded	-
7	Audio Cable	1.5	Unshielded	Unshielded	-
8	AC Cable	1.8	Unshielded	Unshielded	-

UL Japan, Inc.

Head Office EMC Lab.

4383-326 Asama-cho, Ise-shi, Mie-ken 516-0021 JAPAN

Telephone : +81 596 24 8116

Facsimile : +81 596 24 8124

SECTION 5: Conducted Emission

Test Procedure and conditions

EUT was placed on a urethane platform of nominal size, 1.0m by 1.5m, raised 0.8m above the conducting ground plane. The rear of tabletop was located 40cm to the vertical conducting plane. The rear of EUT, including peripherals aligned and flushed with rear of tabletop. All other surfaces of tabletop were at least 80cm from any other grounded conducting surface. EUT was located 80cm from a Line Impedance Stabilization Network (LISN)/ Artificial mains Network (AMN) and excess AC cable was bundled in center.

1) For the tests on EUT with other peripherals (as a whole system)

I/O cable and AC cables that were connected to the peripherals were bundled in center. They were folded back and forth forming a bundle 30cm to 40cm long and were hanged at a 40cm height to the ground plane. All unused 50ohm connectors of the LISN(AMN) were resistivity terminated in 50ohm when not connected to the measuring equipment.

The AC Mains Terminal Continuous disturbance Voltage has been measured with the EUT in a Semi Anechoic Chamber or a Measurement Room.

The EUT was connected to a LISN (AMN).

An overview sweep with peak detection has been performed.

Detector : quasi-peak and average detector (IF BW 9 kHz)
Measurement range : 0.15-30MHz
Test data : APPENDIX 2
Test result : Pass

UL Japan, Inc.

Head Office EMC Lab.

4383-326 Asama-cho, Ise-shi, Mie-ken 516-0021 JAPAN

Telephone : +81 596 24 8116

Facsimile : +81 596 24 8124

SECTION 6: Spurious Emission

[Conducted]

Test Procedure

The Out of Band Emission was measured with a spectrum analyzer connected to the antenna port.

It was measured based on "1. RF antenna conducted test" of "Guidance on Measurement of Digital Transmission Systems Operating under Section 15.247".

The following spectrum analyzer setting was used:

- RBW: 100kHz
- VBW: 300kHz
- Sweep: Auto
- Detector: Peak
- Trace: Max Hold

Test data : APPENDIX 2

Test result : Pass

[Radiated]

Test Procedure

It was measured based on "2. Radiated emission test" of "Guidance on Measurement of Digital Transmission Systems Operating under Section 15.247".

EUT was placed on a urethane platform of nominal size, 1.0m by 1.5m, raised 0.8m above the conducting ground plane.

The Radiated Electric Field Strength intensity has been measured in a Semi Anechoic Chamber with a ground plane and at a distance of 3m(Below 10GHz) and 1m(Upper 10GHz).

The height of the measuring varied between 1 and 4m and EUT was rotated a full revolution in order to obtain the maximum value of the electric field intensity.

The measurements were performed for both vertical and horizontal antenna polarization with the Test Receiver and the Spectrum Analyzer.

The radiated emission measurements were made with the following detector function of the test receiver and the Spectrum analyzer.

The result also satisfied with the general limits specified in section FCC 15.209(a) / RSS-210 2.7 (IC).

Frequency	Below 1GHz	Above 1GHz
Instrument used	Test Receiver	Spectrum Analyzer *1)
Detector	QP: BW 120kHz	PK: RBW:1MHz/VBW: 1MHz
IF Bandwidth		AV *2): RBW:1MHz/VBW: 10Hz

*1) The Spectrum Analyzer was used in 3dB resolution bandwidth.

*2) When using Spectrum analyzer, the test was made with adjusting span to zero by using peak hold.

The test was made on EUT at the normal use position.

Test data : APPENDIX 2

Test result : Pass

UL Japan, Inc.

Head Office EMC Lab.

4383-326 Asama-cho, Ise-shi, Mie-ken 516-0021 JAPAN

Telephone : +81 596 24 8116

Facsimile : +81 596 24 8124

SECTION 7: Bandwidth

6dB Bandwidth

Test Procedure

The bandwidth was measured with a spectrum analyzer connected to the antenna port.
It was measured based on "Guidance on Measurement of Digital Transmission Systems Operating under Section15.247 ".
The following spectrum analyzer setting was used:

- Span: 50MHz
- RBW: 100kHz
- VBW: 300kHz
- Sweep: Auto
- Detector: Peak
- Trace: Max Hold

Test data : APPENDIX 2
Test result : Pass

99% Occupied Bandwidth

Test Procedure

The bandwidth was measured with a spectrum analyzer connected to the antenna port.
The following spectrum analyzer setting was used:

- Span: Enough width to display 20dB Bandwidth
- RBW: as close to 1% of the Span as is possible without being below 1%
- VBW: Three times of RBW
- Sweep: Auto
- Detector: Peak
- Trace: Max Hold

Test data : APPENDIX 2
Test result : Pass

SECTION 8: Maximum Peak Output Power

Test Procedure

The Maximum Peak Output Power was measured with a power meter (tested bandwidth: 50MHz) connected to the antenna port.

It was measured based on "Power Output Option 1" of "Guidance on Measurement of Digital Transmission Systems Operating under Section15.247".

Test data : APPENDIX 2
Test result : Pass

SECTION 9: Peak Power Density

[Conducted]

Test Procedure

The Peak Power Density was measured with a spectrum analyzer connected to the antenna port.

It was measured based on "PSD Option 1" of "Guidance on Measurement of Digital Transmission Systems Operating under Section15.247".

- Span: 18MHz
- RBW: 30kHz *)
- VBW: 100kHz
- Sweep: 600sec
- Detector: Peak
- Trace: Max Hold

*) The test was not performed at RBW: 3kHz that was stated in the Regulation.

However, the measurement value with RBW:3kHz is less than the value of RBW:30kHz and the test data met the limit with RBW:3kHz.

Test data : APPENDIX 2
Test result : Pass

UL Japan, Inc.

Head Office EMC Lab.

4383-326 Asama-cho, Ise-shi, Mie-ken 516-0021 JAPAN

Telephone : +81 596 24 8116

Facsimile : +81 596 24 8124