

FCC Test Report

Product Name	Automotive Radio with Navigation
Model No	CA-180-CTPL-HS
FCC ID	ACJ- CA180CTPLHS

Applicant	Panasonic Corporation of North America
Address	Two Riverfront Plaza, 9th Floor, 07102-5490 Newark, New Jersey, USA

Date of Receipt	Apr. 18, 2017
Issued Date	Apr. 25, 2017
Report No.	1740449R-RFUSP05V00
Report Version	V1.0



The test results relate only to the samples tested.

The test results shown in the test report are traceable to the national/international standard through the calibration report of the equipment and evaluated measurement uncertainty herein.

This report must not be used to claim product endorsement by TAF or any agency of the government.

The test report shall not be reproduced without the written approval of DEKRA Testing and Certification Co., Ltd.

Test Report

Issued Date: Apr. 25, 2017

Report No.: 1740449R-RFUSP05V00



Product Name	Automotive Radio with Navigation
Applicant	Panasonic Corporation of North America
Address	Two Riverfront Plaza, 9th Floor, 07102-5490 Newark, New Jersey, USA
Manufacturer	Panasonic Automotive Systems Company
Model No.	CA-180-CTPL-HS
FCC ID.	ACJ- CA180CTPLHS
EUT Rated Voltage	DC 12V
EUT Test Voltage	DC 12V
Trade Name	Panasonic
Applicable Standard	FCC CFR Title 47 Part 15 Subpart E: 2015 ANSI C63.4: 2014, ANSI C63.10: 2013 789033 D02 General UNII Test Procedures New Rules v01r03
Test Result	Complied

Documented By : Genie Chang
(Senior Adm. Specialist / Genie Chang)

Tested By : Kevin Liu
(Engineer / Kevin Liu)

Approved By : Vincent Lin
(Director / Vincent Lin)

TABLE OF CONTENTS

Description	Page
1. GENERAL INFORMATION.....	5
1.1. EUT Description.....	5
1.2. Operational Description	7
1.3. Tested System Details.....	8
1.4. Configuration of tested System	9
1.5. EUT Exercise Software	9
1.6. Test Facility	10
1.7. List of Test Equipment	11
2. Conducted Emission	12
2.1. Test Setup	12
2.2. Limits	12
2.3. Test Procedure	13
2.4. Uncertainty	13
2.5. Test Result of Conducted Emission.....	14
3. Maximun conducted output power.....	15
3.1. Test Setup	15
3.2. Limits	16
3.3. Test Procedure	17
3.4. Uncertainty	17
3.5. Test Result of Maximum conducted output power.....	18
4. Peak Power Spectral Density	23
4.1. Test Setup	23
4.2. Limits	23
4.3. Test Procedure	24
4.4. Uncertainty	24
4.5. Test Result of Peak Power Spectral Density	25
5. Radiated Emission.....	32
5.1. Test Setup	32
5.2. Limits	33
5.3. Test Procedure	34
5.4. Uncertainty	34
5.5. Test Result of Radiated Emission.....	35
6. Band Edge.....	48
6.1. Test Setup	48
6.2. Limits	49
6.3. Test Procedure	49

6.4.	Uncertainty	49
6.5.	Test Result of Band Edge	50
7.	Occupied Bandwidth.....	64
7.1.	Test Setup	64
7.2.	Limits	64
7.3.	Test Procedure	64
7.4.	Uncertainty	64
7.5.	Test Result of Occupied Bandwidth	65
8.	Frequency Stability	72
8.1.	Test Setup	72
8.2.	Limits	72
8.3.	Test Procedure	72
8.4.	Uncertainty	72
8.5.	Test Result of Frequency Stability.....	73
9.	EMI Reduction Method During Compliance Testing	74

Attachment 1: EUT Test Photographs

Attachment 2: EUT Detailed Photographs

1. GENERAL INFORMATION

1.1. EUT Description

Product Name	Automotive Radio with Navigation
Trade Name	Panasonic
FCC ID.	ACJ- CA180CTPLHS
Model No.	CA-180-CTPL-HS
Frequency Range	802.11a/n-20MHz: 5745-5825MHz 802.11n-40MHz: 5755-5795MHz 802.11ac-80MHz: 5775MHz
Number of Channels	802.11a/n-20MHz: 10; 802.11n-40MHz: 2 802.11ac-80MHz: 1
Data Rate	802.11a: 6 - 54Mbps 802.11n: up to 150Mbps 802.11ac-80MHz: up to 433.3MHz
Channel Control	Auto
Type of Modulation	802.11a/n/ac: OFDM, BPSK, QPSK, 16QAM, 64QAM, 256QAM
Antenna type	PCB Antenna
Antenna Gain	Refer to the table "Antenna List"

Antenna List

No.	Manufacturer	Part No.	Antenna Type	Peak Gain
1	Panasonic	N/A	PCB Antenna	5dBi For 5.725~5.825GHz

Note: 1. The antenna of EUT is conform to FCC 15.203.

2. Only the higher gain antenna was tested and recorded in this report

802.11a/n-20MHz Center Working Frequency of Each Channel:

Channel	Frequency	Channel	Frequency	Channel	Frequency	Channel	Frequency
Channel 149:	5745 MHz	Channel 153:	5765 MHz	Channel 157:	5785 MHz	Channel 161:	5805 MHz
Channel 165:	5825 MHz						

802.11n-40MHz Center Working Frequency of Each Channel:

Channel	Frequency	Channel	Frequency
Channel 151:	5755 MHz	Channel 159:	5795 MHz

802.11ac-80MHz Center Working Frequency of Each Channel:

Channel	Frequency	Channel	Frequency	Channel	Frequency	Channel	Frequency
Channel 155:	5775 MHz						

Note:

1. This device is an Automotive Radio with Navigation with a built-in 802.11a/n/ac WLAN transceiver.
2. Regarding to the operation frequency, the lowest, middle and highest frequency are selected to perform the test.
3. Lowest and highest data rates are tested in each mode. Only worst case is shown in the report.
4. These tests were conducted on a sample of the equipment for the purpose of demonstrating compliance with Part 15 Subpart E for Unlicensed National Information Infrastructure devices.

Test Mode	Mode 1: Transmit (802.11a-6Mbps) Mode 2: Transmit (802.11n-20BW 7.2Mbps) Mode 3: Transmit (802.11n-40BW 15Mbps) Mode 4: Transmit (802.11ac-80BW-32.5Mbps)
-----------	--

1.3. Tested System Details

The types for all equipment, plus descriptions of all cables used in the tested system (including inserted cards) are:

Product	Manufacturer	Model No.	Serial No.	Power Cord
1 Monitor	Panasonic	N/A	N/A	N/A
2 Test Fixture	Intrepidcs	Value LAN3	131774	N/A
3 Notebook PC	DELL	P62G	229FJC2	N/A
4 USB HUB	D-LINK	DVB-H7	DL483G5006220	N/A
5 Test Fixture	Panasonic	N/A	N/A	N/A
6 FLASH 8GB	Kingston	DT100G3	N/A	N/A
7 Ethernet Adapter	TRIPPLITE	U236-000-R	N/A	N/A
8 Battery	YUASA	55B24L-CMF II	N/A	N/A

Signal Cable Type	Signal cable Description
A Signal Cable	Non-shielded, 1.0m
B DC Cable	Non-shielded, 1.8m
C Signal Cable	Non-shielded, 1.2m
D Signal Cable	Non-shielded, 0.2m
E USB Cable	Shielded, 1.1m
F USB Cable	Shielded, 1.8m
G LAN Cable	Non-shielded, 2.2m
H USB Cable	Shielded, 0.1m
I USB Cable	Shielded, 1.8m
J DC Cable	Non-shielded, 0.9m

1.4. Configuration of tested System

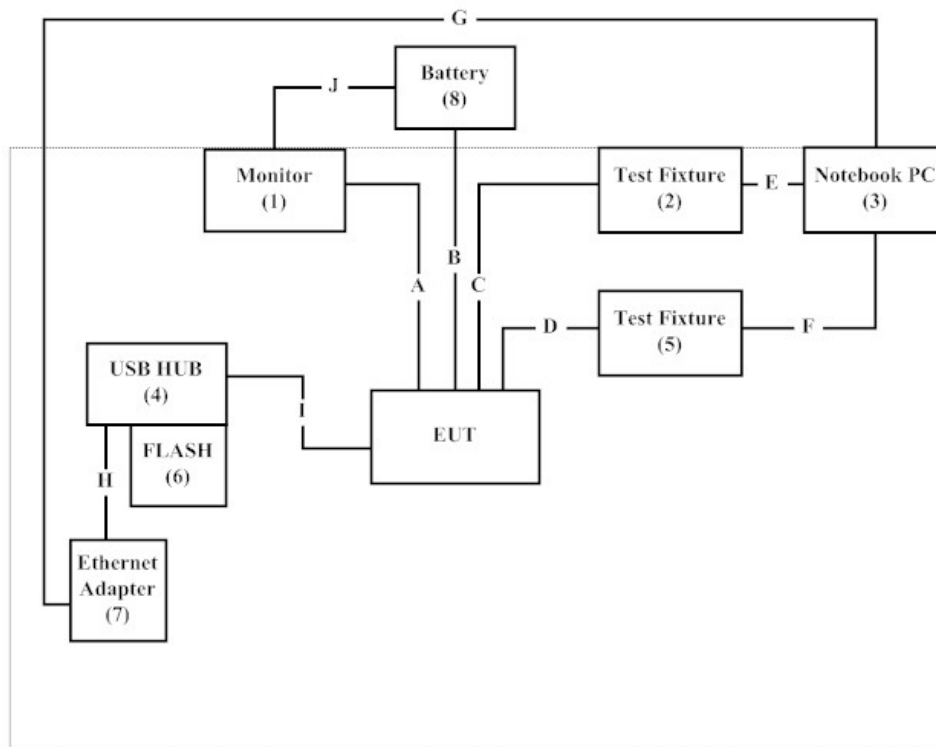

1.5. EUT Exercise Software

1. Setup the EUT as shown in Section 1.4.
2. Execute software "QCA RCT 3.0.174.0" on the EUT.
3. Configure the test mode, the test channel, and the data rate.
4. Press "OK" to start the continuous Transmit.
5. Verify that the EUT works properly.

1.6. Test Facility

Ambient conditions in the laboratory:

Items	Required (IEC 68-1)	Actual
Temperature (°C)	15-35	20-35
Humidity (%RH)	25-75	50-65
Barometric pressure (mbar)	860-1060	950-1000

The related certificate for our laboratories about the test site and management system can be downloaded from DEKRA Testing and Certification Co., Ltd. Web Site:

<http://www.dekra.com.tw/english/about/certificates.aspx?bval=5>

The address and introduction of DEKRA Testing and Certification Co., Ltd. laboratories can be founded in our Web site: http://www.dekra.com.tw/index_en

Site Description: File on
Federal Communications Commission
FCC Engineering Laboratory
7435 Oakland Mills Road
Columbia, MD 21046
Registration Number: 92195

Site Name: DEKRA Testing and Certification Co., Ltd.
Site Address: No.159, Sec. 2, Wenhua 1st Rd., Linkou Dist.,
New Taipei City 24457, Taiwan.
TEL: 886-2-2602-7968 / FAX : 866-2-2602-3286
E-Mail : info.tw@dekra.com

FCC Accreditation Number: TW1014

1.7. List of Test Equipment

For Conducted measurements /ASR3

	Equipment	Manufacturer	Model No.	Serial No.	Cali. Data	Due. Data
X	Temperature Chamber	KSON	THS-D4T-100	A0606	2017.03.31	2018.03.30
X	Spectrum Analyzer	R&S	FSV30	103464	2016.12.14	2017.12.13
X	Power Meter	Anritsu	ML2496A	1548003	2017.01.10	2018.01.09
X	Power Sensor	Anritsu	MA2411B	1531024	2016.12.06	2017.12.05
X	Power Sensor	Anritsu	MA2411B	1531025	2016.12.06	2017.12.05

Note:

1. All equipments are calibrated every one year.
2. The test instruments marked with “X” are used to measure the final test results.
3. Test Software version : QuiTek Conduction Test System V8.0.110

For Radiated measurements /ACB1

	Equipment	Manufacturer	Model No.	Serial No.	Cali. Data	Due. Data
X	Loop Antenna	A.H.	SAS-562B	272	2016.07.21	2017.07.20
X	Bi-Log Antenna	SCHWARZBECK	VULB9168	9168-674	2017.02.09	2018.02.08
X	Horn Antenna	ETS-Lindgren	3117	00203800	2016.10.13	2017.10.12
X	Horn Antenna	Com-Power	AH-840	101087	2016.05.03	2017.05.02
X	Pre-Amplifier	EMCI	EMC001330	980316	2016.04.27	2017.04.26
X	Pre-Amplifier	EMCI	EMC051835SE	980311	2016.04.27	2017.04.26
X	Pre-Amplifier	EMCI	EMC05820SE	980310	2016.04.28	2017.04.27
X	Pre-Amplifier	EMCI	EMC184045SE	980314	2016.05.12	2017.05.11
	Filter	MICRO TRONICS	BRM50702	G251	2016.08.11	2017.08.10
X	Filter	MICRO TRONICS	BRM50716	G188	2016.08.11	2017.08.10
X	EMI Test Receiver	R&S	ESR7	101602	2016.12.15	2017.12.14
X	Spectrum Analyzer	R&S	FSV40	101149	2016.12.14	2017.12.13
X	Coaxial Cable	SUHNER	SUCOFLEX 106	RF002	2016.05.25	2017.05.24
X	Mircoflex Cable	HUBER SUHNER	SUCOFLEX 102	MY3381/2	2016.08.11	2017.08.10

Note:

1. All equipments are calibrated every one year.
2. The test instruments marked with “X” are used to measure the final test results.
3. Test Software version : QuiTek EMI 2.0 V2.1.113

2. Conducted Emission

2.1. Test Setup

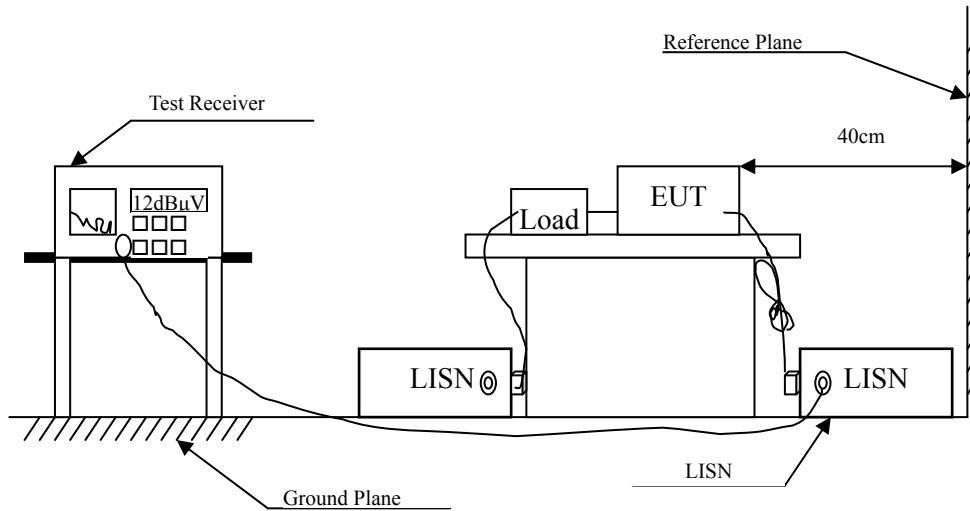

2.2. Limits

FCC Part 15 Subpart C Paragraph 15.207 (dBµV) Limit		
Frequency MHz	Limits	
	QP	AV
0.15 - 0.50	66-56	56-46
0.50-5.0	56	46
5.0 - 30	60	50

Remarks : In the above table, the tighter limit applies at the band edges.

2.3. Test Procedure

The EUT and simulators are connected to the main power through a line impedance stabilization network (L.I.S.N.). This provides a 50 ohm /50uH coupling impedance for the measuring equipment. The peripheral devices are also connected to the main power through a LISN that provides a 50ohm /50uH coupling impedance with 50ohm termination. (Please refers to the block diagram of the test setup and photographs.)

Both sides of A.C. line are checked for maximum conducted interference. In order to find the maximum emission, the relative positions of equipment and all of the interface cables must be changed according to ANSI C63.10:2013 on conducted measurement.

Conducted emissions were investigated over the frequency range from 0.15MHz to 30MHz using a receiver bandwidth of 9kHz.

The EUT was setup to ANSI C63.10, 2014; tested to UNII test procedure of FCC KDB-789033 for compliance to FCC 47CFR Subpart E requirements.

2.4. Uncertainty

±2.35dB

2.5. Test Result of Conducted Emission

Owing to the EUT use DC supply voltage, this test item is not performed.

3. Maximun conducted output power

3.1. Test Setup

99% Occupied Bandwidth

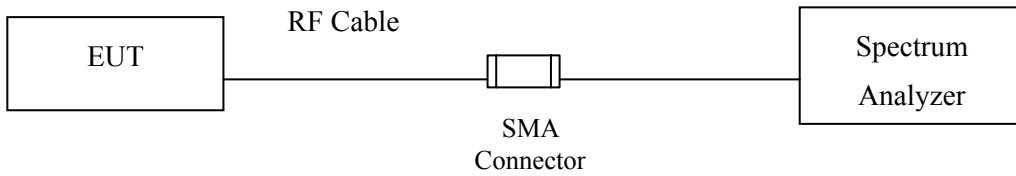

Conduction Power Measurement

Conduction Power Measurement (for 802.11an)

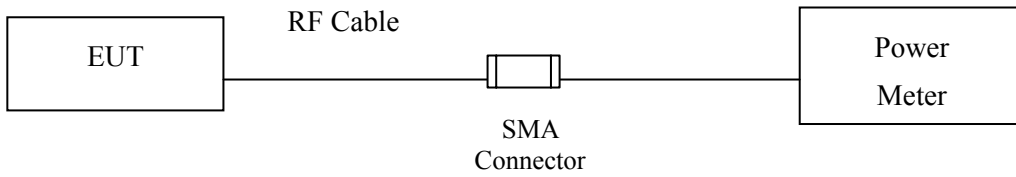

Conduction Power Measurement (for 802.11ac)

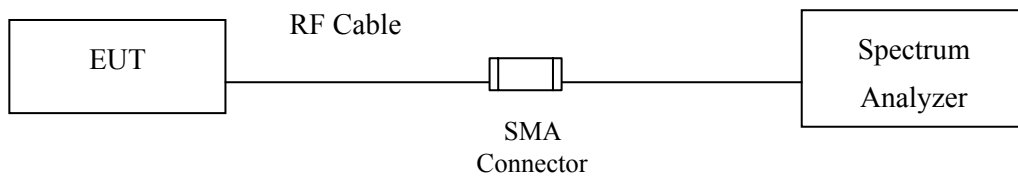

3.2. Limits

3.2.1. For the band 5.15-5.25 GHz,

(i) For an outdoor access point operating in the band 5.15-5.25 GHz, the maximum conducted output power over the frequency band of operation shall not exceed 1 W, provided the maximum antenna gain does not exceed 6 dBi. If transmitting antennas of directional gain greater than 6 dBi are used, the maximum conducted output power shall be reduced by the amount in dB that the directional gain of the antenna exceeds 6 dBi. The maximum e.i.r.p. at any elevation angle above 30 degrees as measured from the horizon must not exceed 125 mW (21 dBm).

(ii) For an indoor access point operating in the band 5.15-5.25 GHz, the maximum conducted output power over the frequency band of operation shall not exceed 1 W provided the maximum antenna gain does not exceed 6 dBi. In addition, if transmitting antennas of directional gain greater than 6 dBi are used, the maximum conducted output power shall be reduced by the amount in dB that the directional gain of the antenna exceeds 6 dBi.

(iii) For fixed point-to-point access points operating in the band 5.15-5.25 GHz, the maximum conducted output power over the frequency band of operation shall not exceed 1 W. Fixed point-to-point U-NII devices may employ antennas with directional gain up to 23 dBi without any corresponding reduction in the maximum conducted output power. For fixed point-to-point transmitters that employ a directional antenna gain greater than 23 dBi, a 1 dB reduction in maximum conducted output power is required for each 1 dB of antenna gain in excess of 23 dBi. Fixed, point-to-point operations exclude the use of point-to-multipoint systems, omnidirectional applications, and multiple collocated transmitters transmitting the same information. The operator of the U-NII device, or if the equipment is professionally installed, the installer, is responsible for ensuring that systems employing high gain directional antennas are used exclusively for fixed, point-to-point operations.

(iv) For mobile and portable client devices in the 5.15-5.25 GHz band, the maximum conducted output power over the frequency band of operation shall not exceed 250 mW provided the maximum antenna gain does not exceed 6 dBi. In addition, if transmitting antennas of directional gain greater than 6 dBi are used, the maximum conducted output power shall be reduced by the amount in dB that the directional gain of the antenna exceeds 6 dBi.

3.2.2. For the 5.25-5.35 GHz and 5.47-5.725 GHz bands, the maximum conducted output power over the frequency bands of operation shall not exceed the lesser of 250 mW or $11 \text{ dBm} + 10 \log B$, where B is the 26 dB emission bandwidth in megahertz. If transmitting antennas of directional gain greater than 6 dBi are used, the maximum conducted output power shall be reduced by the amount in dB that the directional gain of the antenna exceeds 6 dBi.

3.2.3. For the band 5.725-5.85 GHz, the maximum conducted output power over the frequency band of operation shall not exceed 1 W. In addition, If transmitting antennas of directional gain greater than 6 dBi are used, the maximum conducted output power shall be reduced by the amount in dB that the directional gain of the antenna exceeds 6 dBi. However, fixed point-to-point UNII devices operating in this band may employ transmitting antennas with directional gain greater than 6 dBi without any corresponding reduction in transmitter conducted power. Fixed, point-to-point operations exclude the use of point-to-multipoint systems, omnidirectional applications, and multiple collocated transmitters transmitting the same information. The operator of the U-NII device, or if the equipment is professionally installed, the installer, is responsible for ensuring that systems employing high gain directional antennas are used exclusively for fixed, point-to-point operations.

3.3. Test Procedure

As an alternative to FCC KDB-789033, the EUT maximum conducted output power was measured with an average power meter employing a video bandwidth greater the 6dB BW of the emission under test. Maximum conducted output power was read directly from the meter across all data rates, and across three channels within each sub-band. Special care was used to make sure that the EUT was transmitting in continuous mode. This method exceeds the limitations of FCC KDB-789033, and provides more accurate measurements.

802.11an (BW \leq 40MHz) Maximum conducted output power using KDB 789033 section E)3)b) Method PM-G (Measurement using a gated RF average power meter)

Note: the power meter have a video bandwidth that is greater than or equal to the measurement bandwidth, (Anritsu/ MA2411B video bandwidth: 65MHz)

802.11ac (BW=80MHz) Maximum conducted output power using KDB 789033 section E)2)b) Method SA-1 (trace averaging with the EUT transmitting at full power throughout each sweep).

When transmitted signals consist of two or more non-contiguous spectrum segments (e.g., 80+80 MHz mode) or when a single spectrum segment of a transmission crosses the boundary between two adjacent U-NII bands, KDB 644545 D01 section F) procedure is used for measurements.

3.4. Uncertainty

Power Meter: ± 0.95 dB

Spectrum Analyzer: ± 1.30 dB

3.5. Test Result of Maximum conducted output power

Product : Automotive Radio with Navigation
 Test Item : Maximum conducted output power
 Test Mode : Mode 1: Transmit (802.11a-6Mbps)
 Test Date : 2017/04/24

Cable loss=1dB		Maximum conducted output power							
Channel No.	Frequency (MHz)	Data Rate (Mbps)							
		6	9	12	18	24	36	48	54
		Measurement Level (dBm)							
149	5745	7.61	--	--	--	--	--	--	--
157	5785	7.74	7.69	7.63	7.58	7.52	7.47	7.42	7.37
165	5825	7.8	--	--	--	--	--	--	--

Note: Maximum conducted output power Value =Reading value on average power meter + cable loss

Maximum conducted output power Measurement:

Channel No	Frequency Range (MHz)	99% Bandwidth (MHz)	Output Power (dBm)	Output Power Limit	
				(dBm)	dBm+10log(BW)
149	5745	--	7.61	30	--
157	5785	--	7.74	30	--
165	5825	--	7.8	30	--

Note: Power Output Value =Reading value on average power meter + cable loss

Product : Automotive Radio with Navigation
 Test Item : Maximum conducted output power
 Test Mode : Mode 2: Transmit (802.11n-20BW 7.2Mbps)
 Test Date : 2017/04/24

Cable loss=1dB		Maximum conducted output power							
Channel No.	Frequency (MHz)	Data Rate (Mbps)							
		7.2	14.4	21.7	28.9	43.3	57.8	65	72.2
		Measurement Level (dBm)							
149	5745	5.2	--	--	--	--	--	--	--
157	5785	5.31	5.26	5.21	5.16	5.11	5.04	4.99	4.93
165	5825	5.39	--	--	--	--	--	--	--

Note: Maximum conducted output power Value =Reading value on average power meter + cable loss

Maximum conducted output power Measurement:

Channel No	Frequency Range (MHz)	99% Bandwidth (MHz)	Output Power (dBm)	Output Power Limit	
				(dBm)	dBm+10log(BW)
149	5745	--	5.2	30	--
157	5785	--	5.31	30	--
165	5825	--	5.39	30	--

Note: Power Output Value =Reading value on average power meter + cable loss

Product : Automotive Radio with Navigation
 Test Item : Maximum conducted output power
 Test Mode : Mode 3: Transmit (802.11n-40BW 15Mbps)
 Test Date : 2017/04/24

Cable loss=1dB		Maximum conducted output power							
Channel No.	Frequency (MHz)	Data Rate (Mbps)							
		15	30	45	60	90	120	135	150
		Measurement Level (dBm)							
151	5755	4.86	--	--	--	--	--	--	--
159	5795	4.96	4.91	4.86	4.80	4.74	4.69	4.63	4.58

Note: Maximum conducted output power Value =Reading value on average power meter + cable loss

Maximum conducted output power Measurement:

Channel No	Frequency Range (MHz)	99% Bandwidth (MHz)	Output Power (dBm)	Output Power Limit	
				(dBm)	dBm+10log(BW)
151	5755	--	4.86	30	--
159	5795	--	4.96	30	--

Note: Power Output Value =Reading value on average power meter + cable loss

Product : Automotive Radio with Navigation
 Test Item : Maximum conducted output power
 Test Mode : Mode 4: Transmit (802.11ac-80BW-32.5Mbps)
 Test Date : 2017/04/24

Cable loss=1dB		Maximum conducted output power									
Channel No	Frequency (MHz)	Data Rate (Mbps)									
		VTH0	VTH1	VTH2	VTH3	VTH4	VTH5	VTH6	VTH7	VTH8	VTH9
155	5775	5.14	5.08	5.03	4.97	4.92	4.86	4.81	4.75	4.69	4.63

Note: Maximum conducted output power Value =Reading value on Spectrum Analyzer + cable loss

Maximum conducted output power Measurement

Channel No	Frequency Range	99% Bandwidth	Output Power	Output Power Limit		Result
	(MHz)	(MHz)	(dBm)	(dBm)	dBm+10log(BW)	
155	5775	--	5.14	30	--	Pass

Note: Power Output Value = Reading value on Spectrum Analyzer + cable loss

**99% Occupied Bandwidth:
Channel 155**

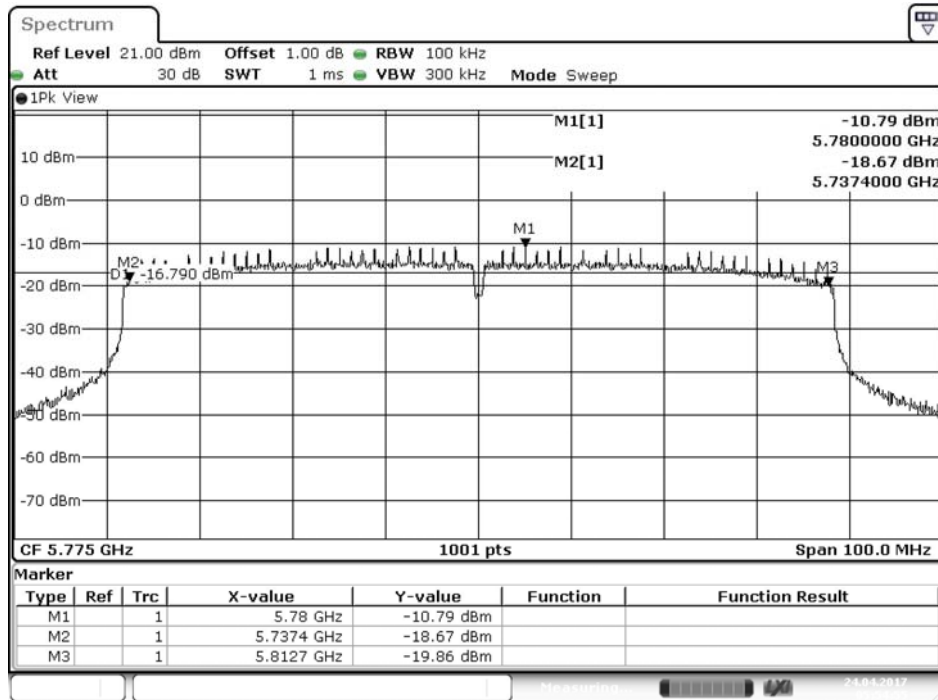

Date: 24.APR.2017 05:54:55

**Maximum conducted output power:
Channel 155**

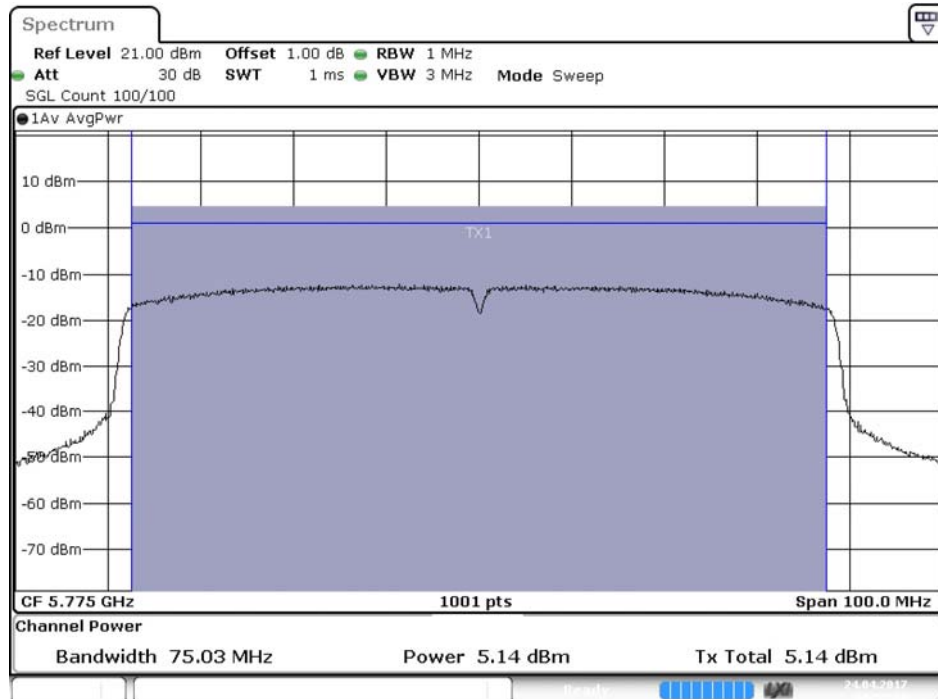

Date: 24.APR.2017 05:55:39

4. Peak Power Spectral Density

4.1. Test Setup

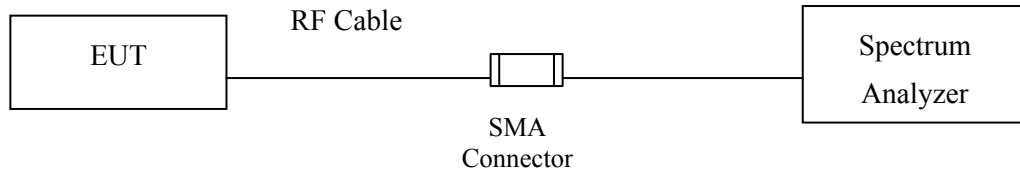

4.2. Limits

- (1) For the band 5.15-5.25 GHz,
 - (i) For an outdoor access point operating in the band 5.15-5.25 GHz, the maximum power spectral density shall not exceed 17 dBm in any 1 megahertz band. If transmitting antennas of directional gain greater than 6 dBi are used, the maximum power spectral density shall be reduced by the amount in dB that the directional gain of the antenna exceeds 6 dBi.
 - (ii) For an indoor access point operating in the band 5.15-5.25 GHz, the maximum power spectral density shall not exceed 17 dBm in any 1 megahertz band. If transmitting antennas of directional gain greater than 6 dBi are used, the maximum power spectral density shall be reduced by the amount in dB that the directional gain of the antenna exceeds 6 dBi.
 - (iii) For fixed point-to-point access points operating in the band 5.15-5.25 GHz, the maximum conducted output power over the frequency band of operation shall not exceed 1 W. Fixed point-to-point U-NII devices may employ antennas with directional gain up to 23 dBi without any corresponding reduction in the maximum conducted output power or maximum power spectral density. For fixed point-to-point transmitters that employ a directional antenna gain greater than 23 dBi, a 1 dB reduction in maximum conducted output power and maximum power spectral density is required for each 1 dB of antenna gain in excess of 23 dBi. Fixed, point-to-point operations exclude the use of point-to-multipoint systems, omnidirectional applications, and multiple collocated transmitters transmitting the same information. The operator of the U-NII device, or if the equipment is professionally installed, the installer, is responsible for ensuring that systems employing high gain directional antennas are used exclusively for fixed, point-to-point operations.
 - (iv) For mobile and portable client devices in the 5.15-5.25 GHz band, the maximum power spectral density shall not exceed 11 dBm in any 1 megahertz band. If transmitting antennas of directional gain greater than 6 dBi are used, the maximum power spectral density shall be reduced by the amount in dB that the directional gain of the antenna exceeds 6 dBi.+
- (2) For the 5.25-5.35 GHz and 5.47-5.725 GHz bands, the maximum power spectral density shall not exceed 11 dBm in any 1 megahertz band. If transmitting antennas of directional gain greater than 6 dBi are used, the maximum power spectral density shall be reduced by the amount in dB that the directional gain of the antenna exceeds 6 dBi.

- (3) For the band 5.725-5.85 GHz, the maximum power spectral density shall not exceed 30 dBm in any 500-kHz band. If transmitting antennas of directional gain greater than 6 dBi are used, the maximum power spectral density shall be reduced by the amount in dB that the directional gain of the antenna exceeds 6 dBi. However, fixed point-to-point UNII devices operating in this band may employ transmitting antennas with directional gain greater than 6 dBi without any corresponding reduction in transmitter conducted power. Fixed, point-to-point operations exclude the use of point-to-multipoint systems, omnidirectional applications, and multiple collocated transmitters transmitting the same information. The operator of the U-NII device, or if the equipment is professionally installed, the installer, is responsible for ensuring that systems employing high gain directional antennas are used exclusively for fixed, point-to-point operations.

4.3. Test Procedure

The EUT was setup to ANSI C63.10, 2009; tested to UNII test procedure of FCC KDB-789033 for compliance to FCC 47CFR Subpart E requirements.

The Peak Power Spectral Density using KDB 789033 section F) procedure, Create an average power spectrum for the EUT operating mode being tested by following the instructions in section E)2) for measuring maximum conducted output power using a spectrum analyzer.

SA-1 method is selected to run the test.

For the band 5.725-5.85 GHz, Scale the observed power level to an equivalent value in 500 kHz by adjusting (increase) the measured power by a bandwidth correction factor (BWCF) where $BWCF = 10\log(500\text{ kHz}/100\text{ kHz}) = 6.98\text{ dB}$.

4.4. Uncertainty

$\pm 1.30\text{ dB}$

4.5. Test Result of Peak Power Spectral Density

Product : Automotive Radio with Navigation
 Test Item : Peak Power Spectral Density
 Test Mode : Mode 1: Transmit (802.11a-6Mbps)
 Test Date : 2017/04/24

Channel Number	Frequency (MHz)	Data Rate (Mbps)	PPSD (dBm)	BWCF (dB)	Total PPSD (dBm)	Required Limit (dBm)	Result
149	5745	6	-11.720	6.980	-4.740	<30	Pass
157	5785	6	-11.750	6.980	-4.770	<30	Pass
165	5825	6	-11.780	6.980	-4.800	<30	Pass

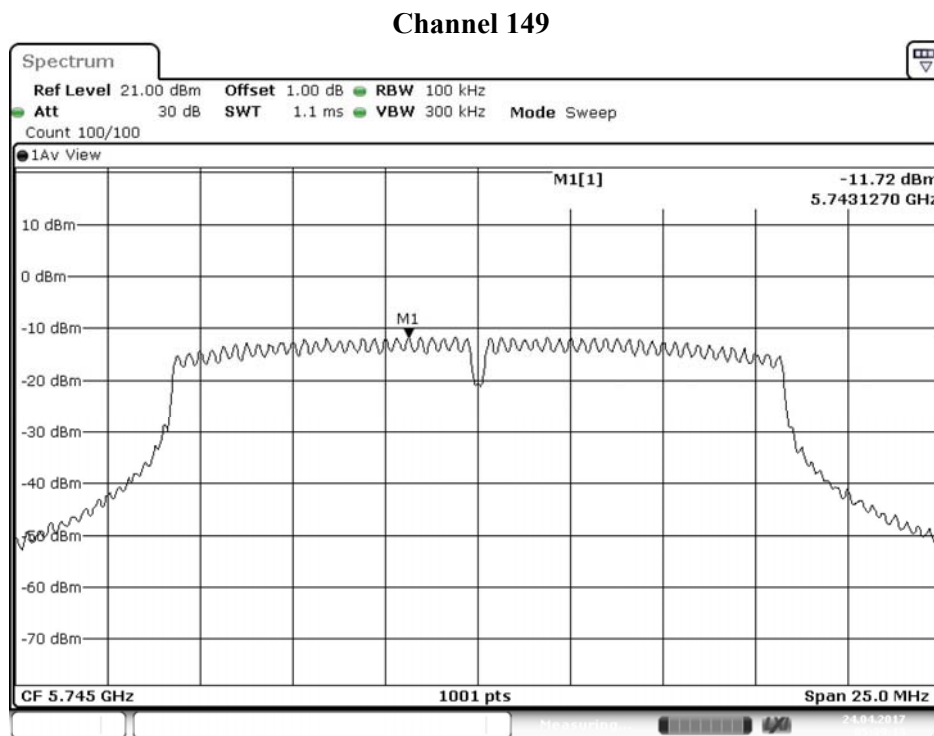

Date: 24.APR.2017 05:39:14

Channel 157

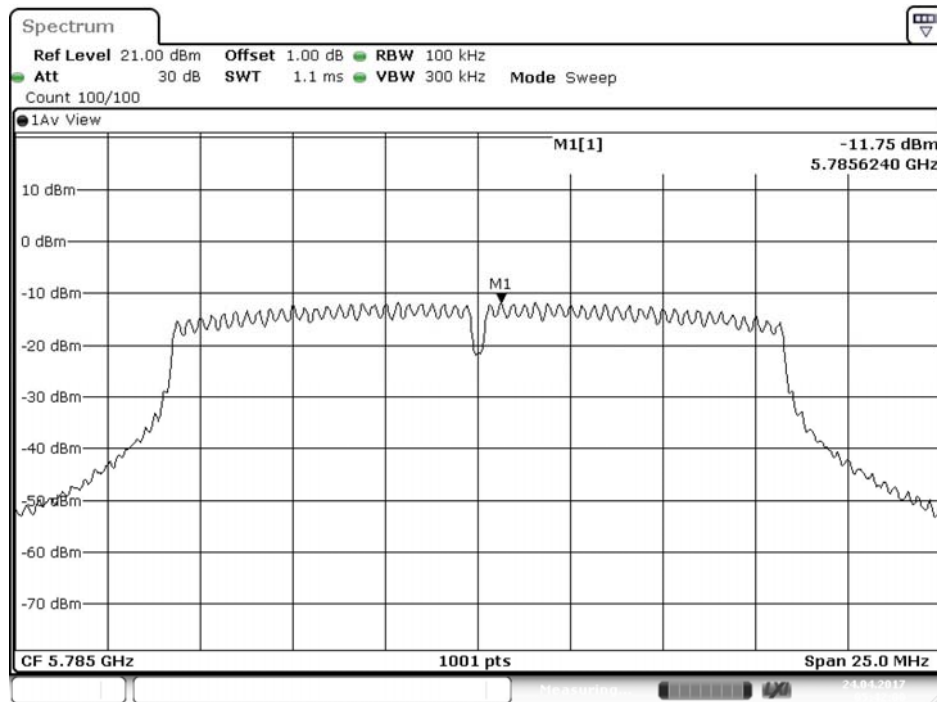

Date: 24.APR.2017 05:42:00

Channel 165

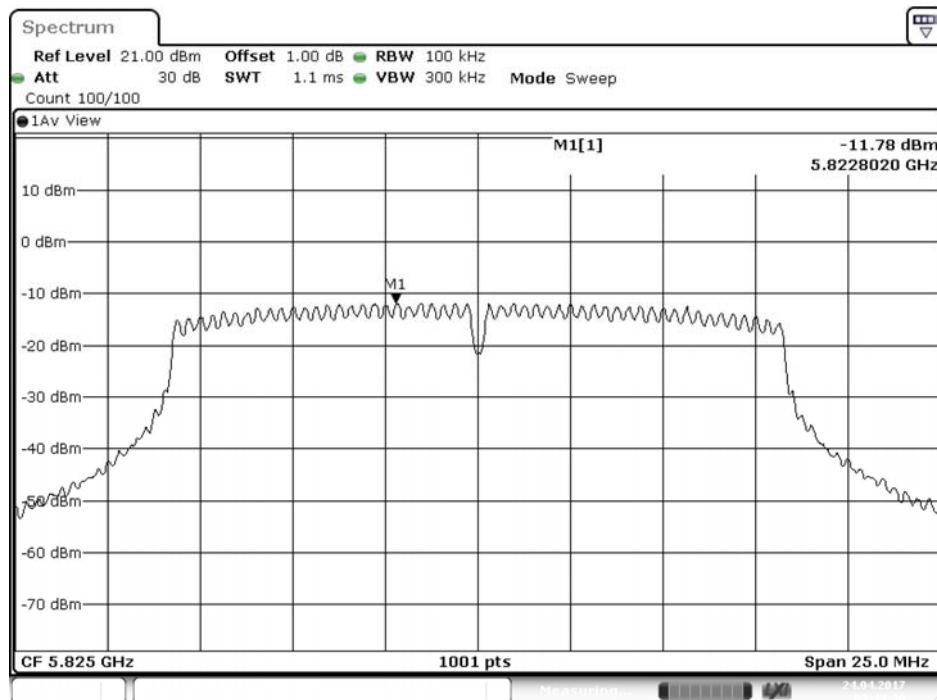

Date: 24.APR.2017 05:43:30

Product : Automotive Radio with Navigation
 Test Item : Peak Power Spectral Density
 Test Mode : Mode 2: Transmit (802.11n-20BW 7.2Mbps)
 Test Date : 2017/04/24

Channel Number	Frequency (MHz)	Data Rate (Mbps)	PPSD (dBm)	BWCF (dB)	Total PSD (dBm)	Required Limit (dBm)	Result
149	5745	7.2	-14.610	6.980	-7.630	<30	Pass
157	5785	7.2	-14.290	6.980	-7.310	<30	Pass
165	5825	7.2	-14.320	6.980	-7.340	<30	Pass

Channel 149

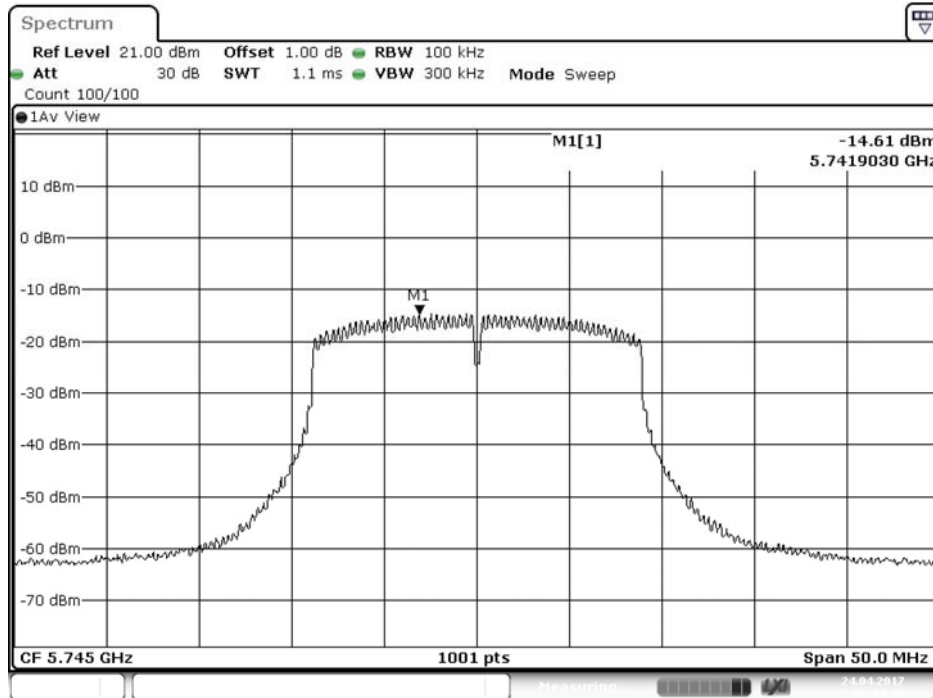

Date: 24.APR.2017 05:45:00

Channel 157

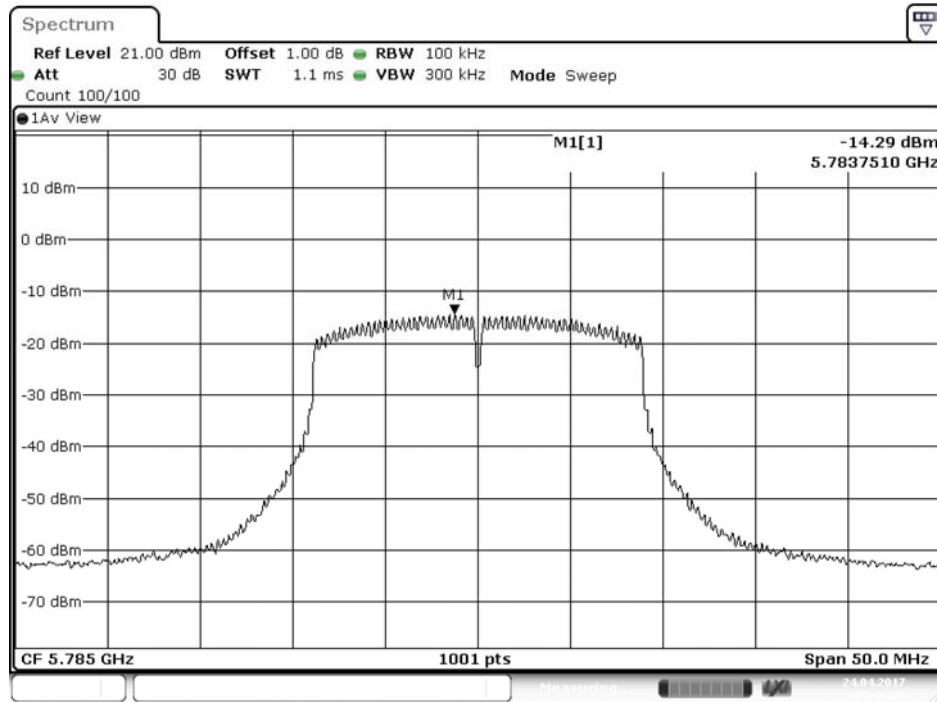

Date: 24.APR.2017 05:46:23

Channel 165

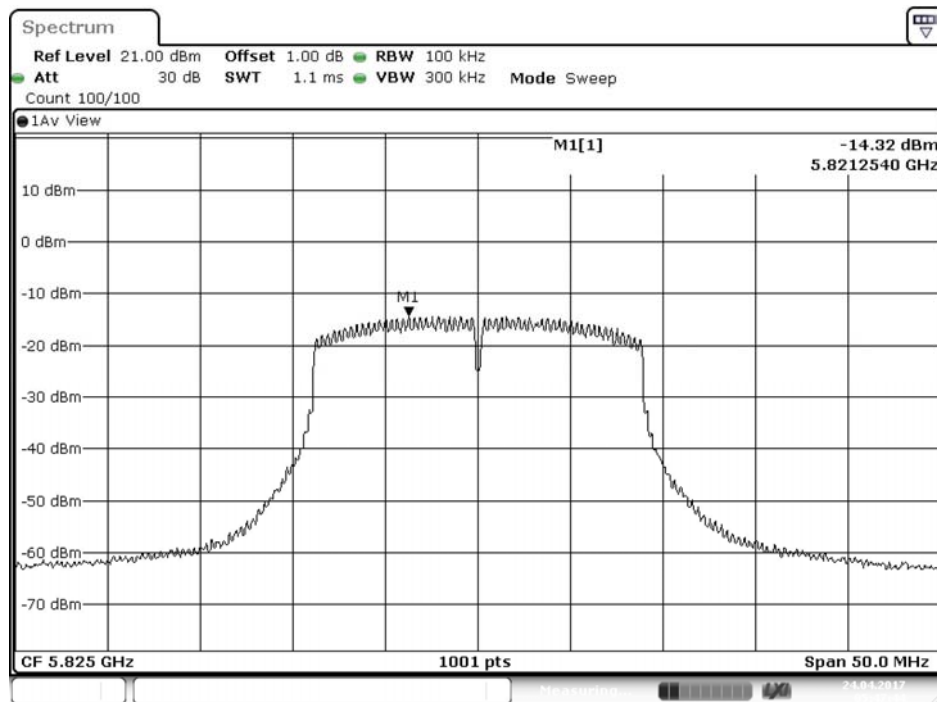

Date: 24.APR.2017 05:47:44

Product : Automotive Radio with Navigation
 Test Item : Peak Power Spectral Density
 Test Mode : Mode 3: Transmit (802.11n-40BW 15Mbps)
 Test Date : 2017/04/24

Channel Number	Frequency (MHz)	Data Rate (Mbps)	PPSD (dBm)	BWCF (dB)	Total PPSD (dBm)	Required Limit (dBm)	Result
151	5755	15	-18.260	6.980	-11.280	<30	Pass
159	5795	15	-18.110	6.980	-11.130	<30	Pass

Channel 151

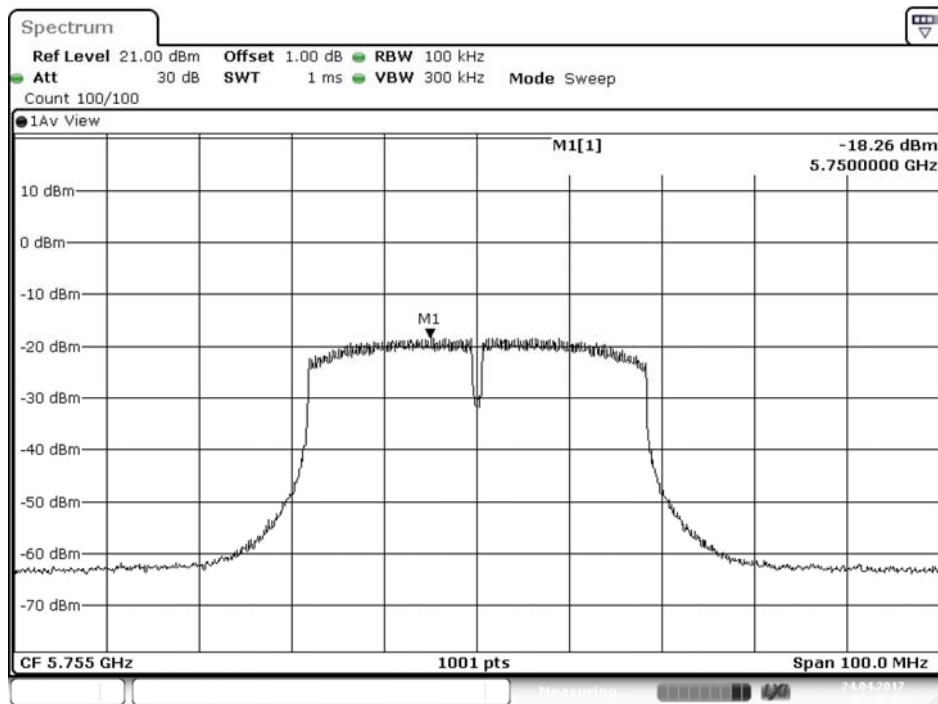

Date: 24.APR.2017 05:49:44

Channel 159

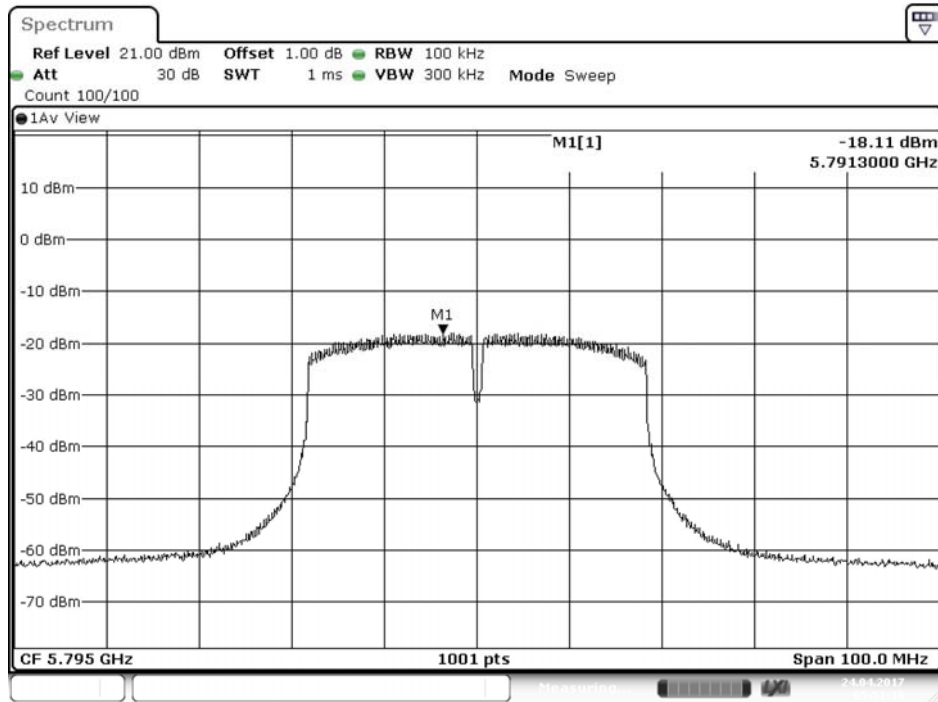

Date: 24.APR.2017 05:51:19

5. Radiated Emission

5.1. Test Setup

Radiated Emission Under 30MHz

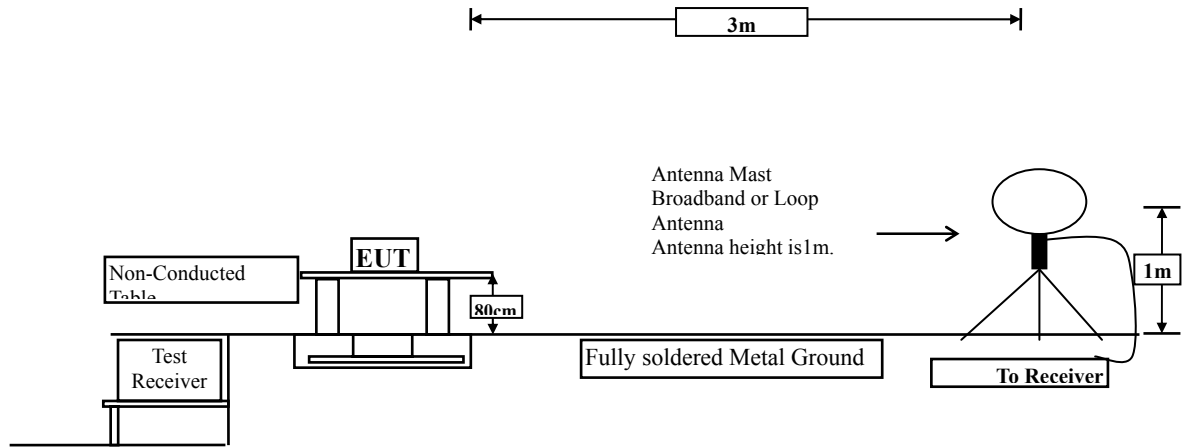

Radiated Emission Below 1GHz

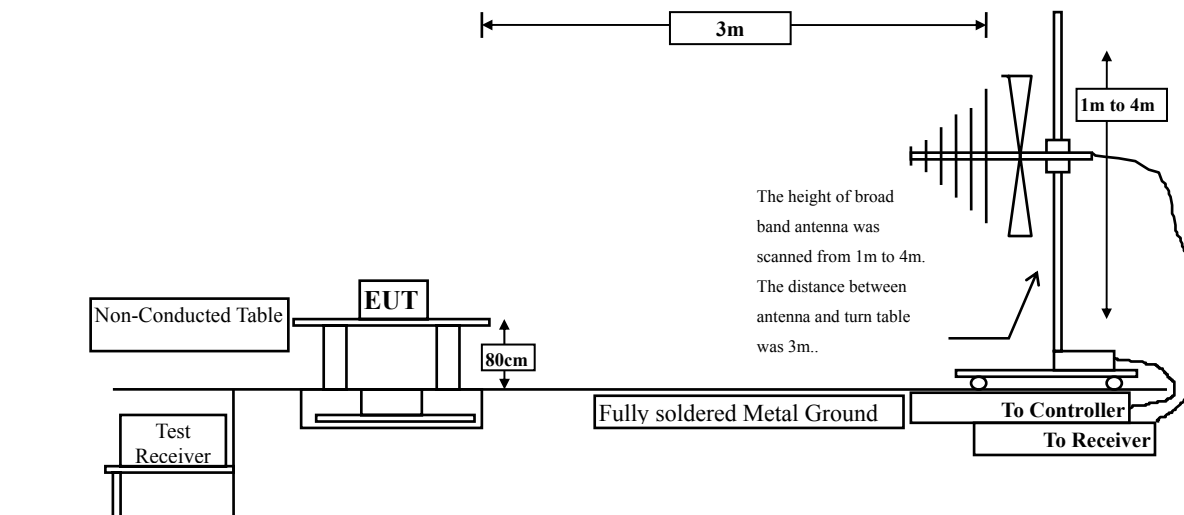

Radiated Emission Above 1GHz

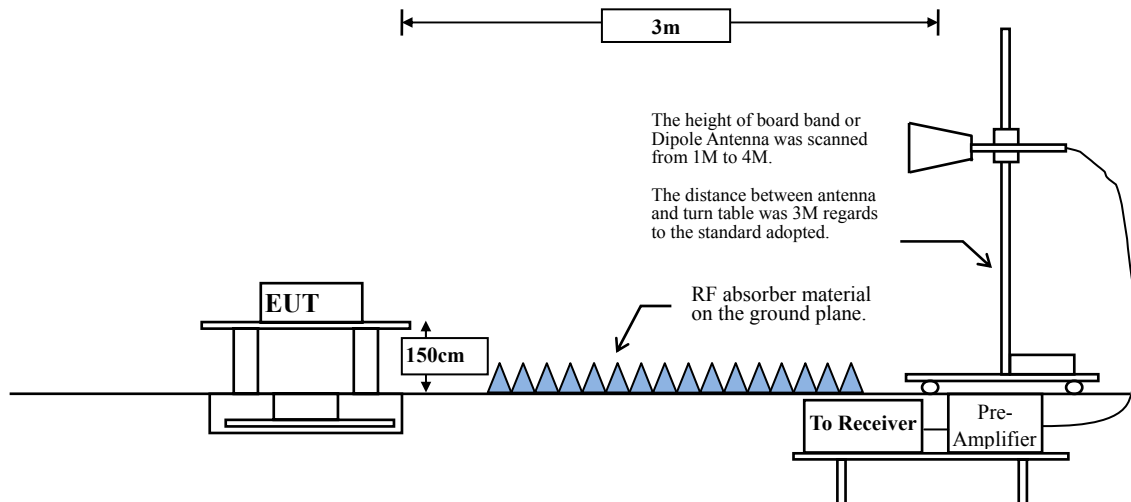

5.2. Limits

Emissions radiated outside of the specified frequency bands, except for harmonics, shall be attenuated by at least 20dB below the level of the fundamental or to the general radiated emission limits in paragraph 15.209, whichever is the lesser attenuation.

FCC Part 15 Subpart C Paragraph 15.209(a) Limits		
Frequency MHz	Field strength (microvolts/meter)	Measurement distance (meter)
0.009-0.490	2400/F(kHz)	300
0.490-1.705	24000/F(kHz)	30
1.705-30	30	30
30-88	100	3
88-216	150	3
216-960	200	3
Above 960	500	3

Remarks: E field strength (dB μ V/m) = 20 log E field strength (uV/m)

5.3. Test Procedure

The EUT was setup according to ANSI C63.10, 2013 and tested according to FCC KDB-789033 test procedure for compliance to FCC 47CFR 15. 407 requirements.

Measuring the frequency range below 1GHz, the EUT is placed on a turn table which is 0.8 meter above ground, when measuring the frequency range above 1GHz, the EUT is placed on a turn table which is 1.5 meter above ground.

The turn table is rotated 360 degrees to determine the position of the maximum emission level.

The EUT was positioned such that the distance from antenna to the EUT was 3 meters.

The antenna is scanned between 1 meter and 4 meters to find out the maximum emission level. This is repeated for both horizontal and vertical polarization of the antenna. In order to find the maximum emission, all of the interface cables were manipulated according to ANSI C63.10: 2013 on radiated measurement.

The resolution bandwidth below 30MHz setting on the field strength meter is 9kHz and 30MHz~1GHz is 120kHz and above 1GHz is 1MHz.

Radiated emission measurements below 30MHz are made using Loop Antenna and 30MHz~1GHz are made using broadband Bilog antenna and above 1GHz are made using Horn Antennas.

The measurement is divided into the Preliminary Measurement and the Final Measurement.

The suspected frequencies are searched for in Preliminary Measurement with the measurement antenna kept pointed at the source of the emission both in azimuth and elevation, with the polarization of the antenna oriented for maximum response. The antenna is pointed at an angle towards the source of the emission, and the EUT is rotated in both height and polarization to maximize the measured emission. The emission is kept within the illumination area of the 3 dB bandwidth of the antenna.

The measurement frequency range from 9kHz - 10th Harmonic of fundamental was investigated.

5.4. Uncertainty

Horizontal polarization :

30-300MHz: ± 4.08 dB ; 300M-1GHz: ± 3.86 dB ; 1-18GHz: ± 3.77 dB ; 18-40GHz: ± 3.98 dB

Vertical polarization :

30-300MHz: ± 4.81 dB ; 300M-1GHz: ± 3.87 dB ; 1-18GHz : ± 3.83 dB ; 18-40GHz: ± 3.98 dB

5.5. Test Result of Radiated Emission

Product : Automotive Radio with Navigation
 Test Item : Harmonic Radiated Emission Data
 Test Mode : Mode 1: Transmit (802.11a-6Mbps) (5745MHz)
 Test Date : 2017/04/22

Frequency MHz	Correct Factor dB	Reading Level dB μ V	Measurement Level dB μ V/m	Margin dB	Limit dB μ V/m
Horizontal					
Peak Detector:					
11490.000	4.208	46.490	50.698	-23.302	74.000
Average Detector:					
--					54.000
Vertical					
Peak Detector:					
11490.000	4.208	44.800	49.008	-24.992	74.000
Average Detector:					
--					54.000

Note:

- All Readings below 1GHz are Quasi-Peak, above 1GHz are performed with peak and/or average measurements as necessary.
- Peak measurements: RBW = 1MHz, VBW = 3 MHz, Sweep: Auto.
- Average measurements: RBW = 1MHz, VBW = 10 Hz, Sweep: Auto.
- Measurement Level = Reading Level + Correct Factor.
- Correct Factor = Antenna factor + Cable loss – Amplifier gain.
- The average measurement was not performed when the peak measured data under the limit of average detection.
- The emission levels of other frequencies are very lower than the limit and not show in test report.

Product : Automotive Radio with Navigation
 Test Item : Harmonic Radiated Emission Data
 Test Mode : Mode 1: Transmit (802.11a-6Mbps) (5785MHz)
 Test Date : 2017/04/22

Frequency MHz	Correct Factor dB	Reading Level dB μ V	Measurement Level dB μ V/m	Margin dB	Limit dB μ V/m
Horizontal					
Peak Detector:					
11570.000	4.420	45.700	50.120	-23.880	74.000
Average Detector:					
--					54.000
Vertical					
Peak Detector:					
11570.000	4.420	45.590	50.010	-23.990	74.000
Average Detector:					
--					54.000

Note:

1. All Readings below 1GHz are Quasi-Peak, above 1GHz are performed with peak and/or average measurements as necessary.
2. Peak measurements: RBW = 1MHz, VBW = 3 MHz, Sweep: Auto.
3. Average measurements: RBW = 1MHz, VBW = 10 Hz, Sweep: Auto.
4. Measurement Level = Reading Level + Correct Factor.
5. Correct Factor = Antenna factor + Cable loss – Amplifier gain.
6. The average measurement was not performed when the peak measured data under the limit of average detection.
7. The emission levels of other frequencies are very lower than the limit and not show in test report.

Product : Automotive Radio with Navigation
 Test Item : Harmonic Radiated Emission Data
 Test Mode : Mode 1: Transmit (802.11a-6Mbps) (5825MHz)
 Test Date : 2017/04/22

Frequency MHz	Correct Factor dB	Reading Level dBµV	Measurement Level dBµV/m	Margin dB	Limit dBµV/m
Horizontal					
Peak Detector:					
11650.000	4.616	45.550	50.166	-23.834	74.000
Average Detector:					
--					54.000
Vertical					
Peak Detector:					
11650.000	4.616	44.650	49.266	-24.734	74.000
Average Detector:					
--					54.000

Note:

1. All Readings below 1GHz are Quasi-Peak, above 1GHz are performed with peak and/or average measurements as necessary.
2. Peak measurements: RBW = 1MHz, VBW = 3 MHz, Sweep: Auto.
3. Average measurements: RBW = 1MHz, VBW = 10 Hz, Sweep: Auto.
4. Measurement Level = Reading Level + Correct Factor.
5. Correct Factor = Antenna factor + Cable loss – Amplifier gain.
6. The average measurement was not performed when the peak measured data under the limit of average detection.
7. The emission levels of other frequencies are very lower than the limit and not show in test report.

Product : Automotive Radio with Navigation
 Test Item : Harmonic Radiated Emission Data
 Test Mode : Mode 2: Transmit (802.11n-20BW 7.2Mbps) (5745MHz)
 Test Date : 2017/04/22

Frequency MHz	Correct Factor dB	Reading Level dB μ V	Measurement Level dB μ V/m	Margin dB	Limit dB μ V/m
Horizontal					
Peak Detector:					
11490.000	4.208	45.810	50.018	-23.982	74.000
Average Detector:					
--					54.000
Vertical					
Peak Detector:					
11490.000	4.208	44.560	48.768	-25.232	74.000
Average Detector:					
--					54.000

Note:

1. All Readings below 1GHz are Quasi-Peak, above 1GHz are performed with peak and/or average measurements as necessary.
2. Peak measurements: RBW = 1MHz, VBW = 3 MHz, Sweep: Auto.
3. Average measurements: RBW = 1MHz, VBW = 10 Hz, Sweep: Auto.
4. Measurement Level = Reading Level + Correct Factor.
5. Correct Factor = Antenna factor + Cable loss – Amplifier gain.
6. The average measurement was not performed when the peak measured data under the limit of average detection.
7. The emission levels of other frequencies are very lower than the limit and not show in test report.

Product : Automotive Radio with Navigation
 Test Item : Harmonic Radiated Emission Data
 Test Mode : Mode 2: Transmit (802.11n-20BW 7.2Mbps) (5785MHz)
 Test Date : 2017/04/22

Frequency MHz	Correct Factor dB	Reading Level dBμV	Measurement Level dBμV/m	Margin dB	Limit dBμV/m
Horizontal					
Peak Detector:					
11570.000	4.420	44.870	49.290	-24.710	74.000
Average Detector:					
--					54.000
Vertical					
Peak Detector:					
11570.000	4.420	45.320	49.740	-24.260	74.000
Average Detector:					
--					54.000

Note:

1. All Readings below 1GHz are Quasi-Peak, above 1GHz are performed with peak and/or average measurements as necessary.
2. Peak measurements: RBW = 1MHz, VBW = 3 MHz, Sweep: Auto.
3. Average measurements: RBW = 1MHz, VBW = 10 Hz, Sweep: Auto.
4. Measurement Level = Reading Level + Correct Factor.
5. Correct Factor = Antenna factor + Cable loss – Amplifier gain.
6. The average measurement was not performed when the peak measured data under the limit of average detection.
7. The emission levels of other frequencies are very lower than the limit and not show in test report.

Product : Automotive Radio with Navigation
 Test Item : Harmonic Radiated Emission Data
 Test Mode : Mode 2: Transmit (802.11n-20BW 7.2Mbps) (5825MHz)
 Test Date : 2017/04/22

Frequency MHz	Correct Factor dB	Reading Level dB μ V	Measurement Level dB μ V/m	Margin dB	Limit dB μ V/m
Horizontal					
Peak Detector:					
11650.000	4.616	44.690	49.306	-24.694	74.000
Average Detector:					
--					54.000
Vertical					
Peak Detector:					
11650.000	4.616	45.070	49.686	-24.314	74.000
Average Detector:					
--					54.000

Note:

- All Readings below 1GHz are Quasi-Peak, above 1GHz are performed with peak and/or average measurements as necessary.
- Peak measurements: RBW = 1MHz, VBW = 3 MHz, Sweep: Auto.
- Average measurements: RBW = 1MHz, VBW = 10 Hz, Sweep: Auto.
- Measurement Level = Reading Level + Correct Factor.
- Correct Factor = Antenna factor + Cable loss – Amplifier gain.
- The average measurement was not performed when the peak measured data under the limit of average detection.
- The emission levels of other frequencies are very lower than the limit and not show in test report.

Product : Automotive Radio with Navigation
 Test Item : Harmonic Radiated Emission Data
 Test Mode : Mode 3: Transmit (802.11n-40BW 15Mbps) (5755MHz)
 Test Date : 2017/04/22

Frequency MHz	Correct Factor dB	Reading Level dB μ V	Measurement Level dB μ V/m	Margin dB	Limit dB μ V/m
Horizontal					
Peak Detector:					
11510.000	4.245	45.620	49.864	-24.136	74.000
Average Detector:					
--					54.000
Vertical					
Peak Detector:					
11510.000	4.245	44.520	48.764	-25.236	74.000
Average Detector:					
--					54.000

Note:

1. All Readings below 1GHz are Quasi-Peak, above 1GHz are performed with peak and/or average measurements as necessary.
2. Peak measurements: RBW = 1MHz, VBW = 3 MHz, Sweep: Auto.
3. Average measurements: RBW = 1MHz, VBW = 10 Hz, Sweep: Auto.
4. Measurement Level = Reading Level + Correct Factor.
5. Correct Factor = Antenna factor + Cable loss – Amplifier gain.
6. The average measurement was not performed when the peak measured data under the limit of average detection.
7. The emission levels of other frequencies are very lower than the limit and not show in test report.

Product : Automotive Radio with Navigation
 Test Item : Harmonic Radiated Emission Data
 Test Mode : Mode 3: Transmit (802.11n-40BW 15Mbps) (5795MHz)
 Test Date : 2017/04/22

Frequency MHz	Correct Factor dB	Reading Level dB μ V	Measurement Level dB μ V/m	Margin dB	Limit dB μ V/m
Horizontal					
Peak Detector:					
11590.000	4.489	44.520	49.009	-24.991	74.000
Average Detector:					
--					54.000
Vertical					
Peak Detector:					
11590.000	4.489	44.480	48.969	-25.031	74.000
Average Detector:					
--					54.000

Note:

1. All Readings below 1GHz are Quasi-Peak, above 1GHz are performed with peak and/or average measurements as necessary.
2. Peak measurements: RBW = 1MHz, VBW = 3 MHz, Sweep: Auto.
3. Average measurements: RBW = 1MHz, VBW = 10 Hz, Sweep: Auto.
4. Measurement Level = Reading Level + Correct Factor.
5. Correct Factor = Antenna factor + Cable loss – Amplifier gain.
6. The average measurement was not performed when the peak measured data under the limit of average detection.
7. The emission levels of other frequencies are very lower than the limit and not show in test report.

Product : Automotive Radio with Navigation
 Test Item : Harmonic Radiated Emission Data
 Test Mode : Mode 4: Transmit (802.11ac-80BW-32.5Mbps) (5775MHz)
 Test Date : 2017/04/22

Frequency MHz	Correct Factor dB	Reading Level dB μ V	Measurement Level dB μ V/m	Margin dB	Limit dB μ V/m
Horizontal					
Peak Detector:					
11550.000	4.370	44.780	49.151	-24.849	74.000
Average Detector:					
--					54.000
Vertical					
Peak Detector:					
11550.000	4.370	45.090	49.461	-24.539	74.000
Average Detector:					
--					54.000

Note:

1. All Readings below 1GHz are Quasi-Peak, above 1GHz are performed with peak and/or average measurements as necessary.
2. Peak measurements: RBW = 1MHz, VBW = 3 MHz, Sweep: Auto.
3. Average measurements: RBW = 1MHz, VBW = 10 Hz, Sweep: Auto.
4. Measurement Level = Reading Level + Correct Factor.
5. Correct Factor = Antenna factor + Cable loss – Amplifier gain.
6. The average measurement was not performed when the peak measured data under the limit of average detection.
7. The emission levels of other frequencies are very lower than the limit and not show in test report.

Product : Automotive Radio with Navigation
 Test Item : General Radiated Emission
 Test Mode : Mode 1: Transmit (802.11a-6Mbps) (5785MHz)
 Test Date : 2017/04/22

Frequency MHz	Correct Factor dB	Reading Level dB μ V	Measurement Level dB μ V/m	Margin dB	Limit dB μ V/m
Horizontal					
Peak Detector					
121.180	-12.979	52.910	39.931	-3.569	43.500
260.860	-11.529	49.710	38.181	-7.819	46.000
385.020	-7.997	48.233	40.236	-5.764	46.000
681.840	-2.288	40.760	38.473	-7.527	46.000
786.600	-0.817	33.245	32.428	-13.572	46.000
875.840	0.246	39.363	39.609	-6.391	46.000
Vertical					
Peak Detector					
159.980	-10.586	50.085	39.499	-4.001	43.500
410.240	-7.345	44.195	36.850	-9.150	46.000
526.640	-5.007	48.127	43.119	-2.881	46.000
617.820	-3.195	41.320	38.125	-7.875	46.000
829.280	-0.312	35.734	35.423	-10.577	46.000
934.040	0.905	39.778	40.684	-5.316	46.000

Note:

1. All Readings below 1GHz are Quasi-Peak, above 1GHz are performed with peak and/or average measurements as necessary.
2. Peak measurements: RBW = 1MHz, VBW = 3 MHz, Sweep: Auto.
3. Average measurements: RBW = 1MHz, VBW = 10 Hz, Sweep: Auto.
4. Measurement Level = Reading Level + Correct Factor.
5. Correct Factor = Antenna factor + Cable loss – Amplifier gain.
6. The average measurement was not performed when the peak measured data under the limit of average detection.
7. The emission levels of other frequencies are very lower than the limit and not show in test report.
8. No emission found between lowest internal used/generated frequency to 30MHz.

Product : Automotive Radio with Navigation
 Test Item : General Radiated Emission
 Test Mode : Mode 2: Transmit (802.11n-20BW 7.2Mbps) (5785MHz)
 Test Date : 2017/04/22

Frequency MHz	Correct Factor dB	Reading Level dB μ V	Measurement Level dB μ V/m	Margin dB	Limit dB μ V/m
Horizontal					
Peak Detector					
136.700	-11.407	48.624	37.217	-6.283	43.500
280.260	-10.520	52.149	41.629	-4.371	46.000
328.760	-9.446	49.299	39.853	-6.147	46.000
681.840	-2.288	42.314	40.027	-5.973	46.000
773.020	-0.972	40.626	39.653	-6.347	46.000
906.880	0.612	39.359	39.971	-6.029	46.000
Vertical					
Peak Detector					
0.000	-11.620	53.359	41.739	-86.781	128.520
101.780	-15.620	53.279	37.659	-5.841	43.500
173.560	-11.522	50.357	38.835	-4.665	43.500
528.580	-4.969	44.997	40.028	-5.972	46.000
627.520	-3.116	43.427	40.311	-5.689	46.000

Note:

1. All Readings below 1GHz are Quasi-Peak, above 1GHz are performed with peak and/or average measurements as necessary.
2. Peak measurements: RBW = 1MHz, VBW = 3 MHz, Sweep: Auto.
3. Average measurements: RBW = 1MHz, VBW = 10 Hz, Sweep: Auto.
4. Measurement Level = Reading Level + Correct Factor.
5. Correct Factor = Antenna factor + Cable loss – Amplifier gain.
6. The average measurement was not performed when the peak measured data under the limit of average detection.
7. The emission levels of other frequencies are very lower than the limit and not show in test report.
8. No emission found between lowest internal used/generated frequency to 30MHz.

Product : Automotive Radio with Navigation
 Test Item : General Radiated Emission
 Test Mode : Mode 3: Transmit (802.11n-40BW 15Mbps) (5755MHz)
 Test Date : 2017/04/22

Frequency MHz	Correct Factor dB	Reading Level dB μ V	Measurement Level dB μ V/m	Margin dB	Limit dB μ V/m
Horizontal					
Peak Detector					
125.060	-12.568	48.147	35.578	-7.922	43.500
414.120	-7.255	42.344	35.089	-10.911	46.000
540.220	-4.734	44.307	39.573	-6.427	46.000
617.820	-3.195	42.928	39.733	-6.267	46.000
848.680	-0.078	38.853	38.775	-7.225	46.000
928.220	0.843	39.995	40.838	-5.162	46.000
Vertical					
Peak Detector					
173.560	-11.522	49.067	37.545	-5.955	43.500
423.820	-7.028	44.269	37.240	-8.760	46.000
528.580	-4.969	46.253	41.284	-4.716	46.000
625.580	-3.133	44.581	41.448	-4.552	46.000
740.040	-1.378	40.663	39.285	-6.715	46.000
912.700	0.674	39.433	40.108	-5.892	46.000

Note:

- All Readings below 1GHz are Quasi-Peak, above 1GHz are performed with peak and/or average measurements as necessary.
- Peak measurements: RBW = 1MHz, VBW = 3 MHz, Sweep: Auto.
- Average measurements: RBW = 1MHz, VBW = 10 Hz, Sweep: Auto.
- Measurement Level = Reading Level + Correct Factor.
- Correct Factor = Antenna factor + Cable loss – Amplifier gain.
- The average measurement was not performed when the peak measured data under the limit of average detection.
- The emission levels of other frequencies are very lower than the limit and not show in test report.
- No emission found between lowest internal used/generated frequency to 30MHz.

Product : Automotive Radio with Navigation
 Test Item : General Radiated Emission
 Test Mode : Mode 4: Transmit (802.11ac-80BW-32.5Mbps) (5775MHz)
 Test Date : 2017/04/22

Frequency MHz	Correct Factor dB	Reading Level dB μ V	Measurement Level dB μ V/m	Margin dB	Limit dB μ V/m
Horizontal					
Peak Detector					
125.060	-12.568	47.578	35.009	-8.491	43.500
423.820	-7.028	42.599	35.570	-10.430	46.000
540.220	-4.734	43.563	38.829	-7.171	46.000
617.820	-3.195	39.734	36.539	-9.461	46.000
751.680	-1.224	39.623	38.399	-7.601	46.000
947.620	1.053	38.347	39.401	-6.599	46.000
Vertical					
Peak Detector					
173.560	-11.522	47.451	35.929	-7.571	43.500
319.060	-9.661	44.278	34.617	-11.383	46.000
423.820	-7.028	45.739	38.710	-7.290	46.000
528.580	-4.969	45.287	40.318	-5.682	46.000
633.340	-3.065	43.802	40.737	-5.263	46.000
947.620	1.053	39.004	40.058	-5.942	46.000

Note:

1. All Readings below 1GHz are Quasi-Peak, above 1GHz are performed with peak and/or average measurements as necessary.
2. Peak measurements: RBW = 1MHz, VBW = 3 MHz, Sweep: Auto.
3. Average measurements: RBW = 1MHz, VBW = 10 Hz, Sweep: Auto.
4. Measurement Level = Reading Level + Correct Factor.
5. Correct Factor = Antenna factor + Cable loss – Amplifier gain.
6. The average measurement was not performed when the peak measured data under the limit of average detection.
7. The emission levels of other frequencies are very lower than the limit and not show in test report.
8. No emission found between lowest internal used/generated frequency to 30MHz.

6. Band Edge

6.1. Test Setup

RF Conducted Measurement:

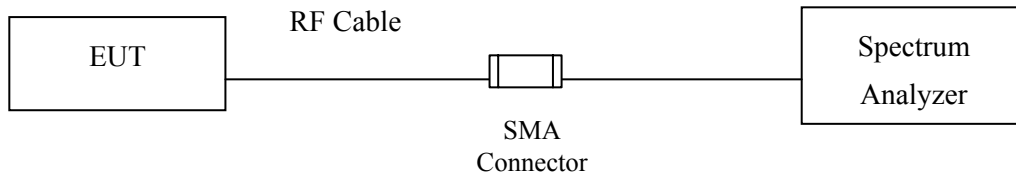

RF Radiated Measurement:

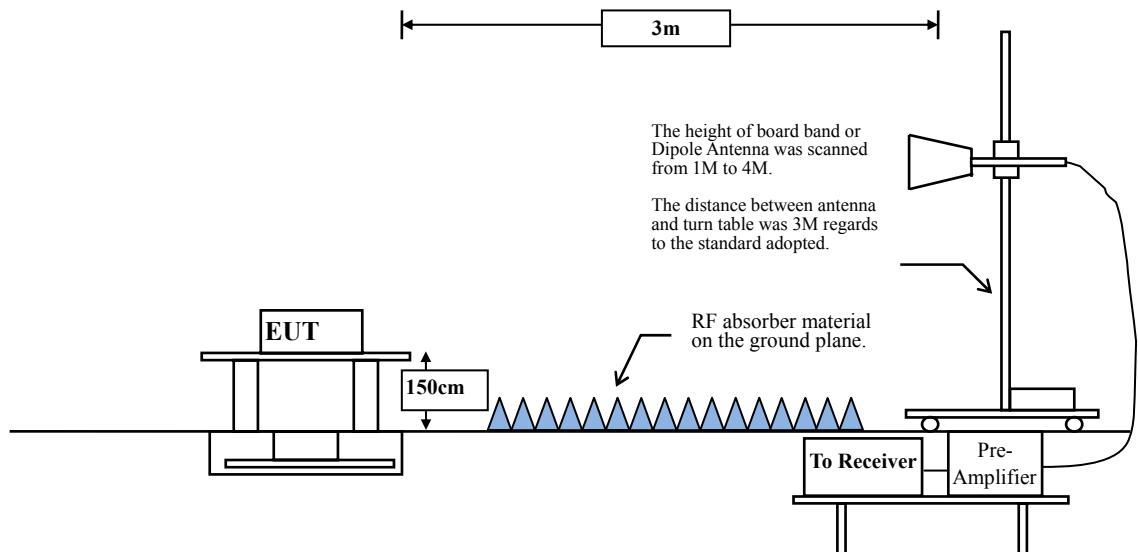

6.2. Limits

The provisions of Section 15.205 of this part apply to intentional radiators operating under this section.

Radiated emissions which fall in the restricted bands, as defined in Section 15.205, must also comply with the radiated emission limits specified in Section 15.209:

FCC Part 15 Subpart C Paragraph 15.209 Limits		
Frequency MHz	uV/m @3m	dB μ V/m@3m
30-88	100	40
88-216	150	43.5
216-960	200	46
Above 960	500	54

Remarks :

1. RF Voltage (dB μ V) = 20 log RF Voltage (uV)
2. In the Above Table, the tighter limit applies at the band edges.
3. Distance refers to the distance in meters between the measuring instrument antenna and the closed point of any part of the device or system.

6.3. Test Procedure

The EUT is placed on a turn table which is 1.5 meter above ground. The turn table can rotate 360 degrees to determine the position of the maximum emission level. The EUT was positioned such that the distance from antenna to the EUT was 3 meters.

The antenna can move up and down between 1 meter and 4 meters to find out the maximum emission level.

Both horizontal and vertical polarization of the antenna are set on measurement. In order to find the maximum emission, all of the interface cables must be manipulated according to ANSI C63.10:2013 on radiated measurement.

The bandwidth below 1GHz setting on the field strength meter is 120 kHz, above 1GHz are 1 MHz. The EUT was setup to ANSI C63.10, 2013; tested to UNII test procedure of FCC KDB-789033 for compliance to FCC 47CFR Subpart E requirements.

6.4. Uncertainty

Conducted: ± 1.23 dB

Radiated:

Horizontal polarization : 1-18GHz: ± 3.77 dB

Vertical polarization : 1-18GHz : ± 3.83 dB

6.5. Test Result of Band Edge

Product : Automotive Radio with Navigation
 Test Item : Band Edge Data
 Test Mode : Mode 1: Transmit (802.11a-6Mbps) (5745MHz)
 Test Date : 2017/04/22

RF Radiated Measurement:

	Frequency (MHz)	Correct Factor (dB)	Reading Level (dBm)	Measure Level (dBm/m)	Margin (dB)	Limit (dBm/m)	Result
Horizontal	5646.667	18.472	31.998	50.470	-17.750	68.220	Pass
Horizontal	5650.000	18.483	29.256	47.738	-20.482	68.220	Pass
Horizontal	5674.312	18.555	31.392	49.947	-36.254	86.201	Pass
Horizontal	5700.000	18.632	30.276	48.908	-56.292	105.200	Pass
Horizontal	5710.072	18.663	31.947	50.610	-57.410	108.020	Pass
Horizontal	5720.000	18.693	30.244	48.937	-61.863	110.800	Pass
Horizontal	5723.768	18.706	33.320	52.026	-67.365	119.391	Pass
Horizontal	5725.000	18.711	32.501	51.212	-70.988	122.200	Pass
Horizontal	5747.102	18.780	77.030	95.810	--	--	--

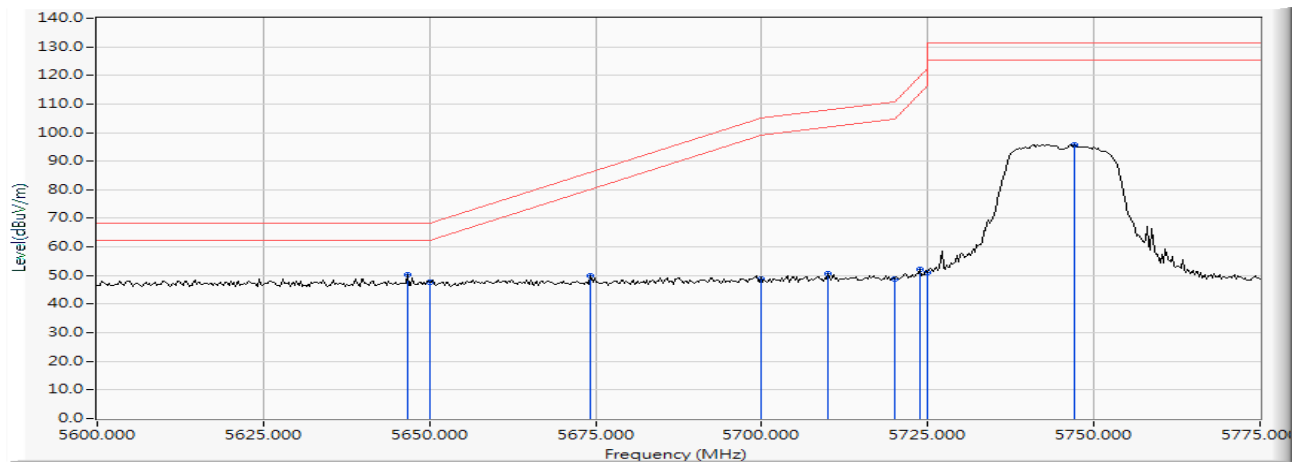

	Frequency (MHz)	Correct Factor (dB)	Reading Level (dBm)	Measure Level (dBm/m)	Margin (dB)	Limit (dBm/m)	Result
Vertical	5645.399	18.468	30.874	49.342	-18.878	68.220	Pass
Vertical	5650.000	18.483	28.619	47.101	-21.119	68.220	Pass
Vertical	5695.616	18.619	31.386	50.005	-51.953	101.958	Pass
Vertical	5700.000	18.632	29.708	48.340	-56.860	105.200	Pass
Vertical	5703.986	18.646	35.961	54.606	-51.710	106.316	Pass
Vertical	5720.000	18.693	30.572	49.265	-61.535	110.800	Pass
Vertical	5723.261	18.704	33.978	52.682	-65.553	118.235	Pass
Vertical	5725.000	18.711	32.361	51.072	-71.128	122.200	Pass
Vertical	5741.268	18.767	78.817	97.583	--	--	--

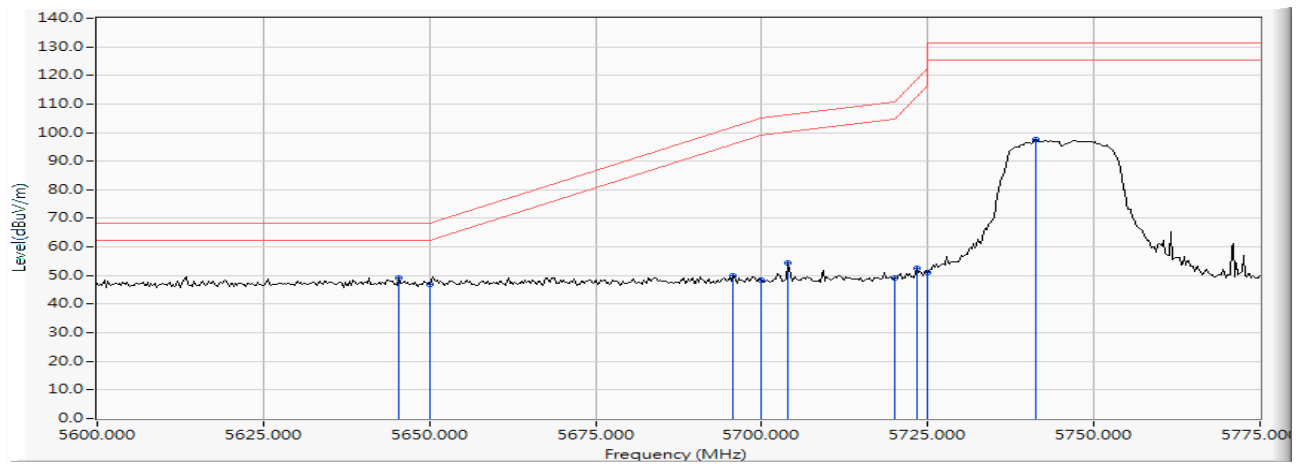

Product : Automotive Radio with Navigation
 Test Item : Band Edge Data
 Test Mode : Mode 1: Transmit (802.11a-6Mbps) (5825MHz)
 Test Date : 2017/04/22

RF Radiated Measurement:

	Frequency (MHz)	Correct Factor (dB)	Reading Level (dBm)	Measure Level (dBm/m)	Margin (dB)	Limit (dBm/m)	Result
Horizontal	5823.478	19.021	74.657	93.678	--	--	--
Horizontal	5850.000	19.103	32.076	51.179	-71.021	122.200	Pass
Horizontal	5855.000	19.115	29.958	49.074	-61.726	110.800	Pass
Horizontal	5857.971	19.123	33.237	52.360	-57.608	109.968	Pass
Horizontal	5875.000	19.177	29.729	48.906	-56.294	105.200	Pass
Horizontal	5902.029	19.254	33.233	52.486	-32.713	85.199	Pass
Horizontal	5925.000	19.333	30.427	49.759	-18.441	68.220	Pass
Horizontal	5928.406	19.343	31.812	51.154	-17.066	68.220	Pass

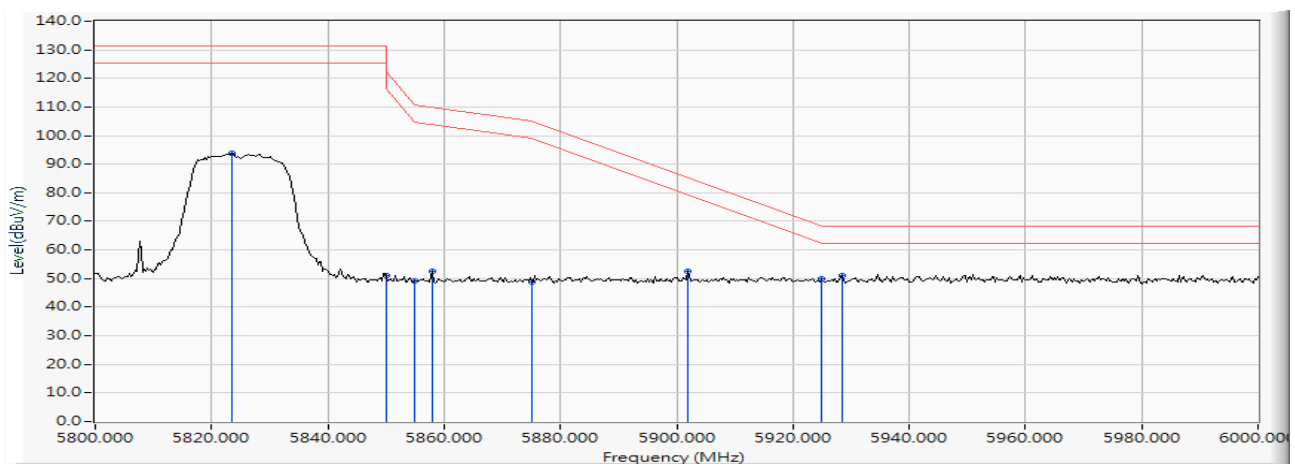

	Frequency (MHz)	Correct Factor (dB)	Reading Level (dBm)	Measure Level (dBm/m)	Margin (dB)	Limit (dBm/m)	Result
Vertical	5828.986	19.033	80.821	99.854	--	--	--
Vertical	5850.000	19.103	31.338	50.441	-71.759	122.200	Pass
Vertical	5855.000	19.115	32.141	51.257	-59.543	110.800	Pass
Vertical	5857.971	19.123	33.295	52.418	-57.550	109.968	Pass
Vertical	5875.000	19.177	30.644	49.821	-55.379	105.200	Pass
Vertical	5915.072	19.300	31.858	51.158	-24.389	75.547	Pass
Vertical	5925.000	19.333	30.857	50.189	-18.011	68.220	Pass
Vertical	5940.290	19.376	32.203	51.579	-16.641	68.220	Pass

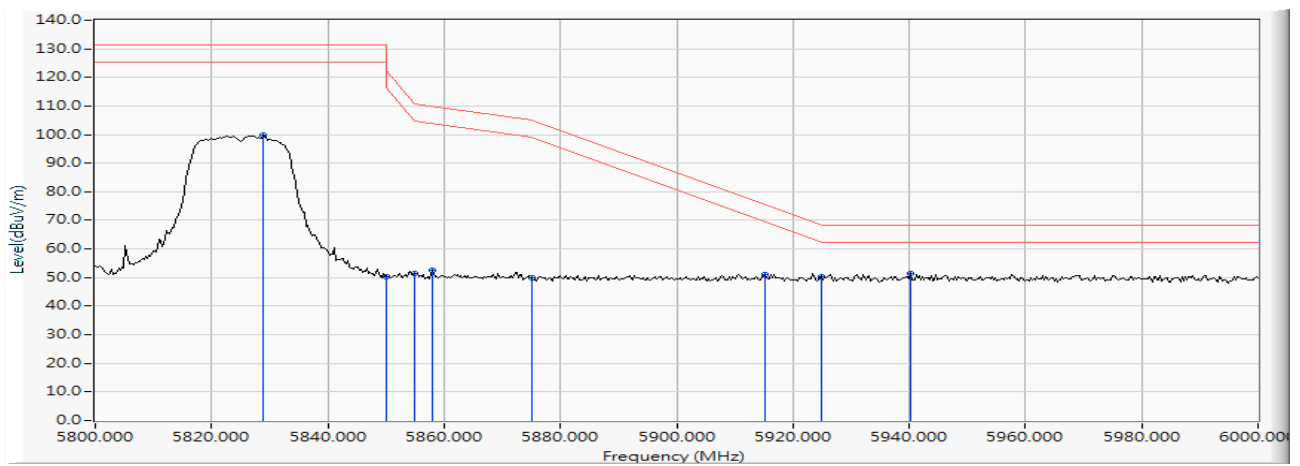

Product : Automotive Radio with Navigation
 Test Item : Band Edge Data
 Test Mode : Mode 2: Transmit (802.11n-20BW 7.2Mbps) (5745MHz)
 Test Date : 2017/04/22

RF Radiated Measurement:

	Frequency (MHz)	Correct Factor (dB)	Reading Level (dBm)	Measure Level (dBm/m)	Margin (dB)	Limit (dBm/m)	Result
Horizontal	5633.986	18.433	30.352	48.785	-19.435	68.220	Pass
Horizontal	5650.000	18.483	29.048	47.530	-20.690	68.220	Pass
Horizontal	5661.884	18.517	31.266	49.784	-27.225	77.009	Pass
Horizontal	5700.000	18.632	29.208	47.840	-57.360	105.200	Pass
Horizontal	5707.029	18.654	32.854	51.508	-55.660	107.168	Pass
Horizontal	5720.000	18.693	30.692	49.385	-61.415	110.800	Pass
Horizontal	5721.232	18.697	35.055	53.752	-59.857	113.609	Pass
Horizontal	5725.000	18.711	31.119	49.830	-72.370	122.200	Pass
Horizontal	5742.283	18.769	76.015	94.784	--	--	--

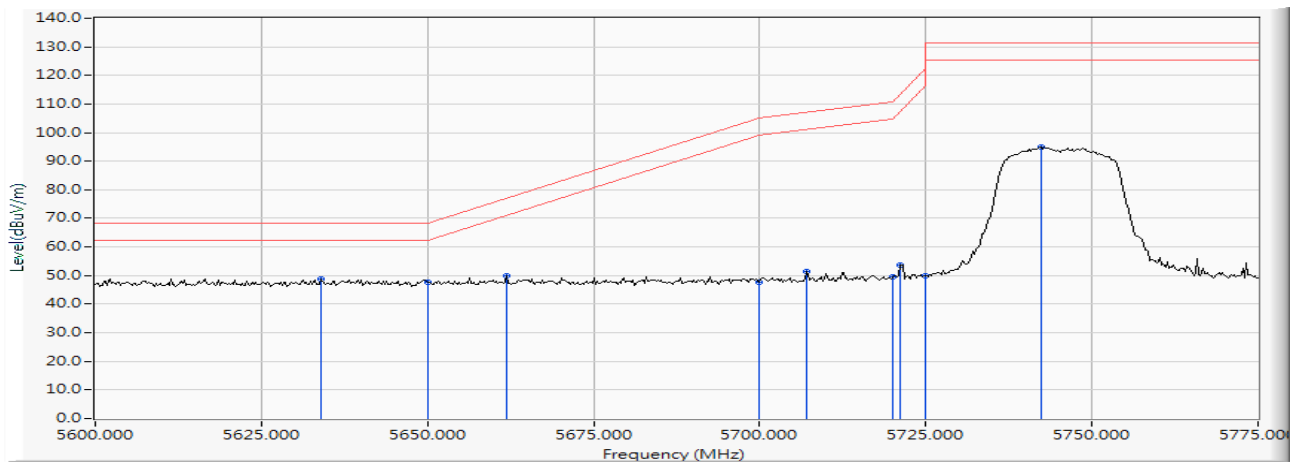

	Frequency (MHz)	Correct Factor (dB)	Reading Level (dBm)	Measure Level (dBm/m)	Margin (dB)	Limit (dBm/m)	Result
Vertical	5639.565	18.451	30.576	49.026	-19.194	68.220	Pass
Vertical	5650.000	18.483	29.151	47.633	-20.587	68.220	Pass
Vertical	5697.645	18.625	32.256	50.881	-52.577	103.458	Pass
Vertical	5700.000	18.632	30.522	49.154	-56.046	105.200	Pass
Vertical	5710.833	18.665	38.397	57.062	-51.171	108.233	Pass
Vertical	5720.000	18.693	32.688	51.381	-59.419	110.800	Pass
Vertical	5724.022	18.707	37.901	56.608	-63.362	119.970	Pass
Vertical	5725.000	18.711	33.642	52.353	-69.847	122.200	Pass
Vertical	5742.536	18.769	79.285	98.054	--	--	--

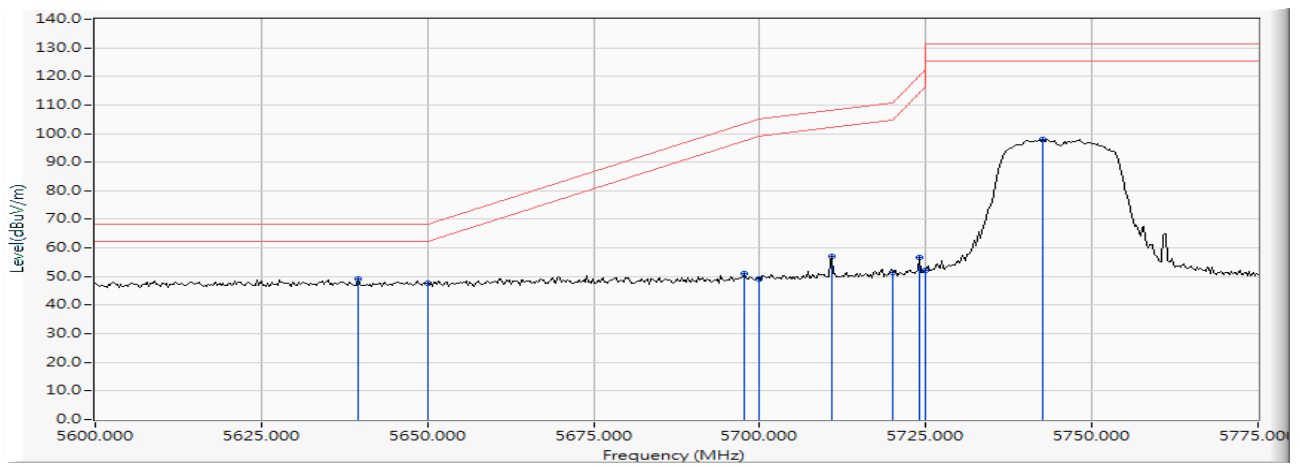

Product : Automotive Radio with Navigation
 Test Item : Band Edge Data
 Test Mode : Mode 2: Transmit (802.11n-20BW 7.2Mbps) (5825MHz)
 Test Date : 2017/04/22

RF Radiated Measurement:

	Frequency (MHz)	Correct Factor (dB)	Reading Level (dBm)	Measure Level (dBm/m)	Margin (dB)	Limit (dBm/m)	Result
Horizontal	5826.957	19.028	74.377	93.405	--	--	--
Horizontal	5850.000	19.103	30.046	49.149	-73.051	122.200	Pass
Horizontal	5852.464	19.109	31.742	50.851	-65.731	116.582	Pass
Horizontal	5855.000	19.115	30.783	49.899	-60.901	110.800	Pass
Horizontal	5868.406	19.153	31.710	50.863	-56.183	107.046	Pass
Horizontal	5875.000	19.177	30.883	50.060	-55.140	105.200	Pass
Horizontal	5912.174	19.290	32.393	51.683	-26.008	77.691	Pass
Horizontal	5925.000	19.333	31.004	50.336	-17.864	68.220	Pass
Horizontal	5931.014	19.350	32.276	51.626	-16.594	68.220	Pass

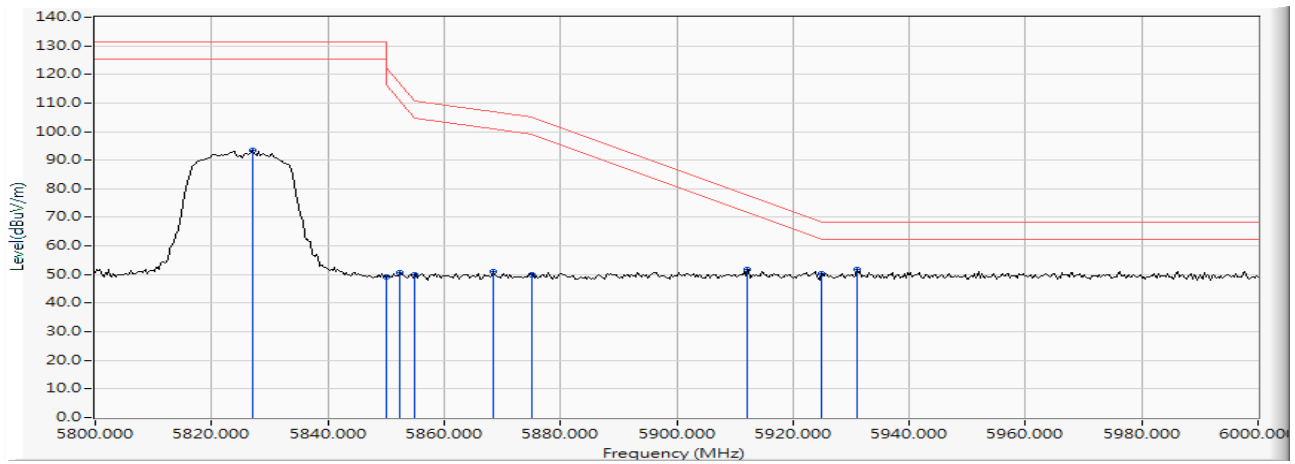

	Frequency (MHz)	Correct Factor (dB)	Reading Level (dBm)	Measure Level (dBm/m)	Margin (dB)	Limit (dBm/m)	Result
Vertical	5826.957	19.028	75.832	94.860	--	--	--
Vertical	5850.000	19.103	31.098	50.201	-71.999	122.200	Pass
Vertical	5851.884	19.108	31.895	51.003	-66.901	117.904	Pass
Vertical	5855.000	19.115	30.425	49.541	-61.259	110.800	Pass
Vertical	5864.348	19.139	31.938	51.077	-57.106	108.183	Pass
Vertical	5875.000	19.177	30.763	49.940	-55.260	105.200	Pass
Vertical	5912.174	19.290	31.906	51.196	-26.495	77.691	Pass
Vertical	5925.000	19.333	29.443	48.775	-19.425	68.220	Pass
Vertical	5931.014	19.350	31.907	51.257	-16.963	68.220	Pass

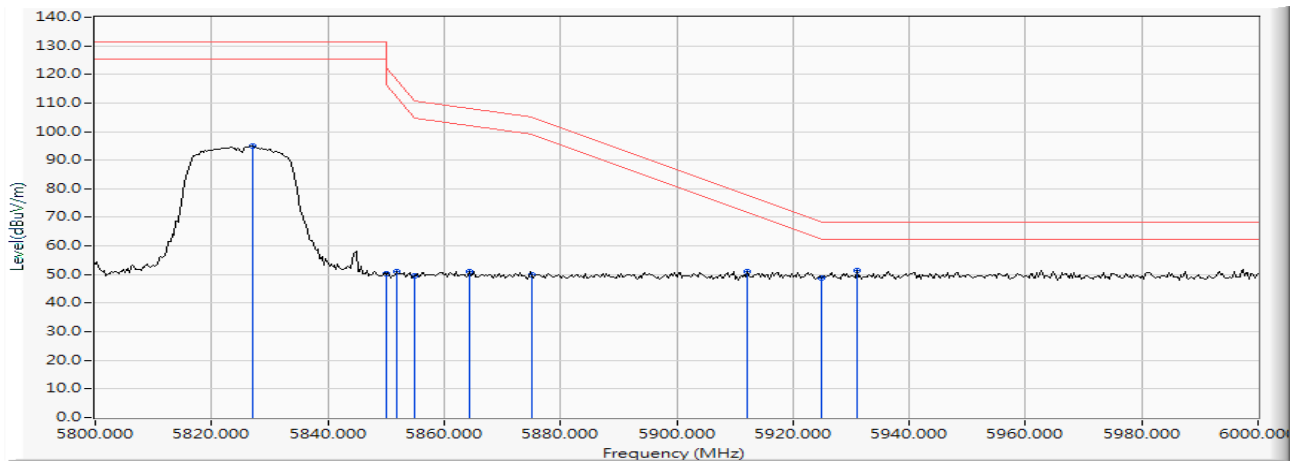

Product : Automotive Radio with Navigation
 Test Item : Band Edge Data
 Test Mode : Mode 3: Transmit (802.11n-40BW 15Mbps) (5755MHz)
 Test Date : 2017/04/22

RF Radiated Measurement:

	Frequency (MHz)	Correct Factor (dB)	Reading Level (dBm)	Measure Level (dBm/m)	Margin (dB)	Limit (dBm/m)	Result
Horizontal	5635.000	18.436	30.834	49.270	-18.950	68.220	Pass
Horizontal	5650.000	18.483	28.987	47.469	-20.751	68.220	Pass
Horizontal	5651.232	18.485	31.375	49.861	-19.270	69.131	Pass
Horizontal	5700.000	18.632	28.875	47.507	-57.693	105.200	Pass
Horizontal	5718.949	18.690	34.758	53.448	-57.058	110.506	Pass
Horizontal	5720.000	18.693	31.071	49.764	-61.036	110.800	Pass
Horizontal	5723.515	18.705	32.436	51.141	-67.673	118.814	Pass
Horizontal	5725.000	18.711	31.533	50.244	-71.956	122.200	Pass
Horizontal	5747.102	18.780	72.567	91.347	--	--	--

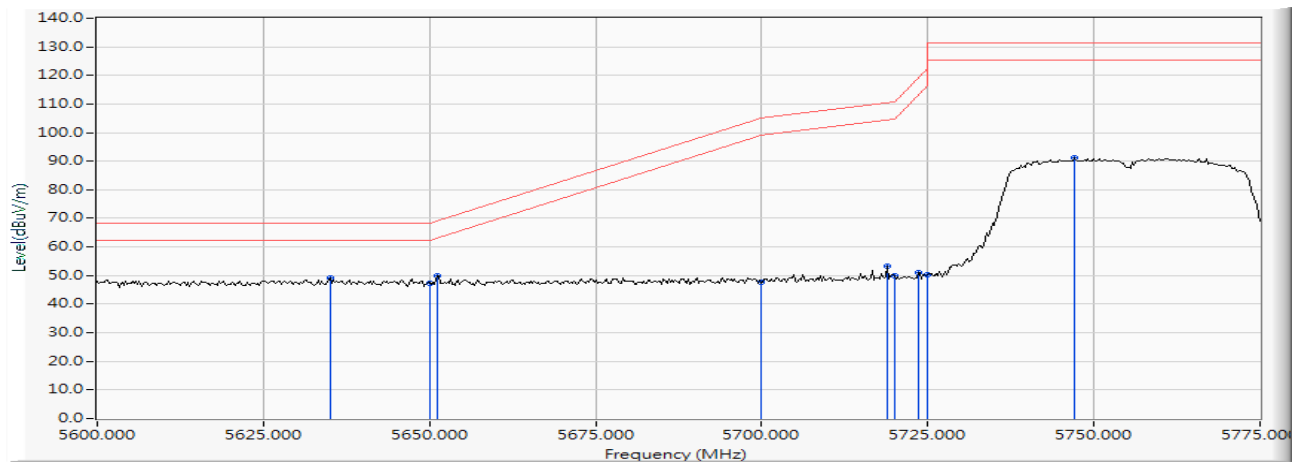

	Frequency (MHz)	Correct Factor (dB)	Reading Level (dBm)	Measure Level (dBm/m)	Margin (dB)	Limit (dBm/m)	Result
Vertical	5630.181	18.422	31.097	49.519	-18.701	68.220	Pass
Vertical	5650.000	18.483	28.981	47.463	-20.757	68.220	Pass
Vertical	5695.362	18.619	35.820	54.438	-47.332	101.770	Pass
Vertical	5700.000	18.632	32.270	50.902	-54.298	105.200	Pass
Vertical	5714.130	18.675	39.982	58.657	-50.499	109.156	Pass
Vertical	5720.000	18.693	33.446	52.139	-58.661	110.800	Pass
Vertical	5725.000	18.711	45.105	63.816	-58.384	122.200	Pass
Vertical	5748.370	18.783	76.552	95.335	--	--	--

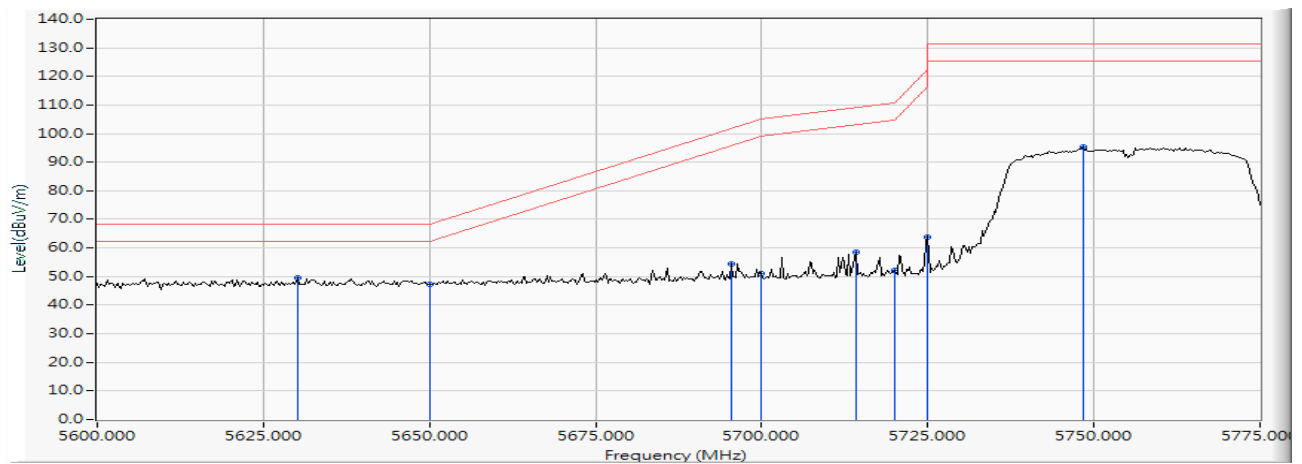

Product : Automotive Radio with Navigation
 Test Item : Band Edge Data
 Test Mode : Mode 3: Transmit (802.11n-40BW 15Mbps) (5795MHz)
 Test Date : 2017/04/22

RF Radiated Measurement:

	Frequency (MHz)	Correct Factor (dB)	Reading Level (dBm)	Measure Level (dBm/m)	Margin (dB)	Limit (dBm/m)	Result
Horizontal	5797.500	18.942	68.042	86.984	--	--	--
Horizontal	5850.000	19.103	30.242	49.345	-72.855	122.200	Pass
Horizontal	5851.304	19.106	31.095	50.201	-69.026	119.227	Pass
Horizontal	5855.000	19.115	29.755	48.871	-61.929	110.800	Pass
Horizontal	5856.848	19.121	31.978	51.098	-59.185	110.283	Pass
Horizontal	5875.000	19.177	30.147	49.324	-55.876	105.200	Pass
Horizontal	5880.000	19.195	31.907	51.102	-50.398	101.500	Pass
Horizontal	5925.000	19.333	30.227	49.559	-18.641	68.220	Pass
Horizontal	5932.174	19.353	31.881	51.234	-16.986	68.220	Pass

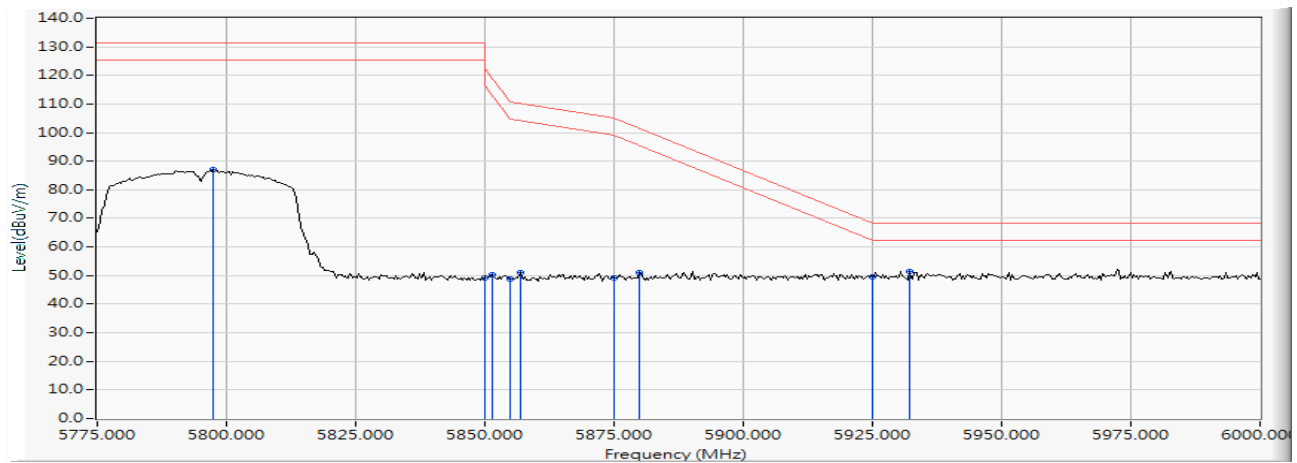

	Frequency (MHz)	Correct Factor (dB)	Reading Level (dBm)	Measure Level (dBm/m)	Margin (dB)	Limit (dBm/m)	Result
Vertical	5798.152	18.945	75.455	94.400	--	--	--
Vertical	5850.000	19.103	31.047	50.150	-72.050	122.200	Pass
Vertical	5853.913	19.113	32.561	51.674	-61.604	113.278	Pass
Vertical	5855.000	19.115	30.616	49.732	-61.068	110.800	Pass
Vertical	5869.891	19.159	33.052	52.211	-54.420	106.631	Pass
Vertical	5875.000	19.177	29.970	49.147	-56.053	105.200	Pass
Vertical	5904.783	19.264	32.385	51.648	-31.513	83.161	Pass
Vertical	5925.000	19.333	30.740	50.072	-18.128	68.220	Pass
Vertical	5943.261	19.382	32.508	51.891	-16.329	68.220	Pass

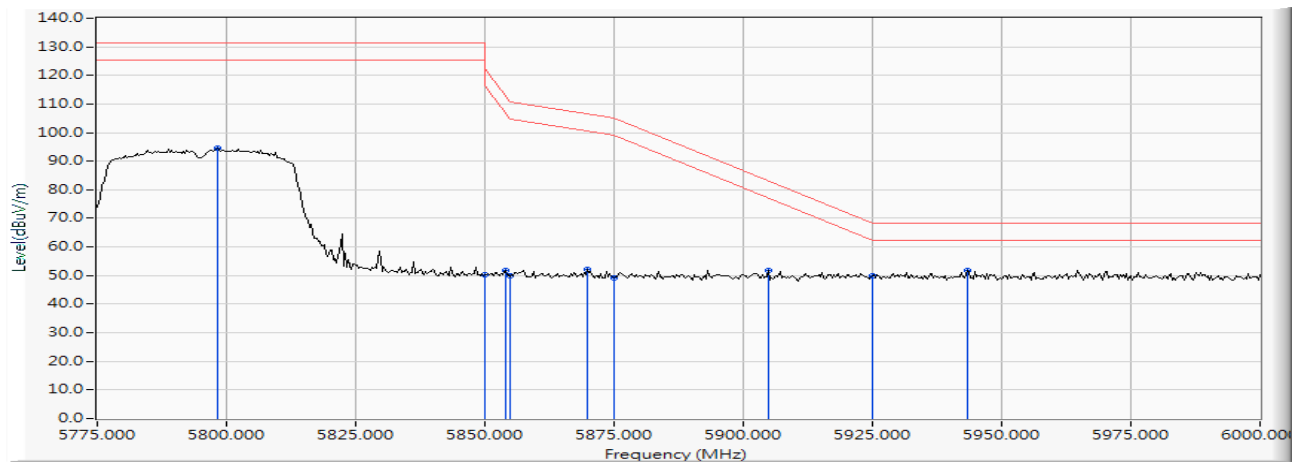

Product : Automotive Radio with Navigation
 Test Item : Band Edge Data
 Test Mode : Mode 4: Transmit (802.11ac-80BW-32.5Mbps) (5775MHz)
 Test Date : 2017/04/22

RF Radiated Measurement:

	Frequency (MHz)	Correct Factor (dB)	Reading Level (dBm)	Measure Level (dBm/m)	Margin (dB)	Limit (dBm/m)	Result
Horizontal	5641.159	18.456	31.499	49.954	-18.266	68.220	Pass
Horizontal	5650.000	18.483	30.294	48.776	-19.444	68.220	Pass
Horizontal	5673.623	18.554	31.500	50.053	-35.639	85.692	Pass
Horizontal	5700.000	18.632	30.165	48.797	-56.403	105.200	Pass
Horizontal	5706.667	18.653	32.390	51.043	-56.024	107.067	Pass
Horizontal	5720.000	18.693	30.469	49.162	-61.638	110.800	Pass
Horizontal	5725.000	18.711	30.825	49.536	-72.664	122.200	Pass
Horizontal	5768.696	18.846	69.343	88.189	--	--	--
Horizontal	5850.000	19.103	30.572	49.675	-72.525	122.200	Pass
Horizontal	5855.000	19.115	30.930	50.046	-60.754	110.800	Pass
Horizontal	5868.406	19.153	31.614	50.767	-56.279	107.046	Pass
Horizontal	5875.000	19.177	29.951	49.128	-56.072	105.200	Pass
Horizontal	5889.855	19.222	31.846	51.068	-43.139	94.207	Pass
Horizontal	5925.000	19.333	30.641	49.973	-18.227	68.220	Pass
Horizontal	5939.710	19.374	31.954	51.328	-16.892	68.220	Pass

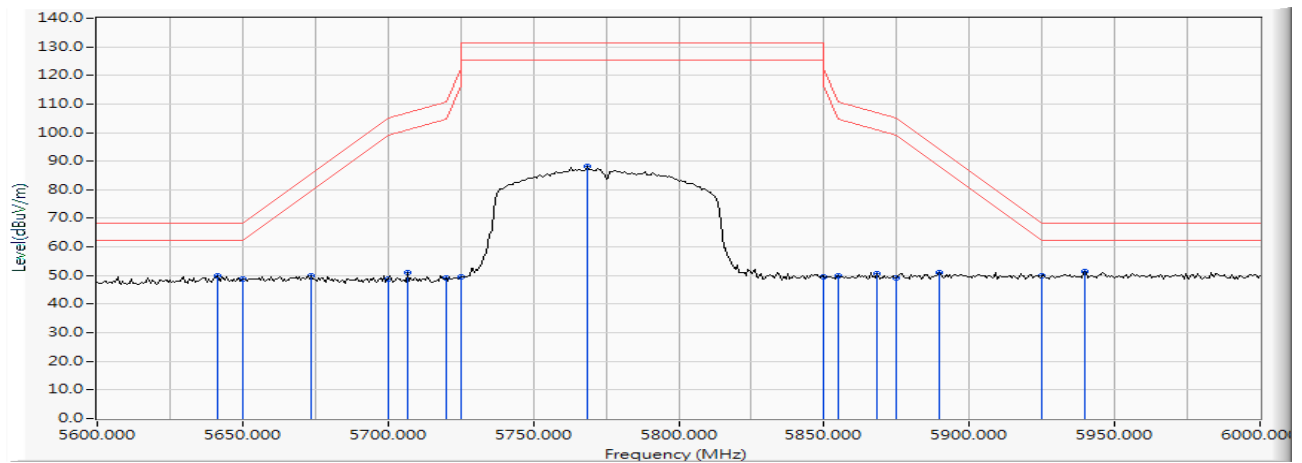

	Frequency (MHz)	Correct Factor (dB)	Reading Level (dBm)	Measure Level (dBm/m)	Margin (dB)	Limit (dBm/m)	Result
Vertical	5646.377	18.471	32.219	50.690	-17.530	68.220	Pass
Vertical	5650.000	18.483	31.638	50.120	-18.100	68.220	Pass
Vertical	5697.971	18.626	34.338	52.964	-50.735	103.699	Pass
Vertical	5700.000	18.632	33.580	52.212	-52.988	105.200	Pass
Vertical	5707.246	18.654	35.414	54.069	-53.160	107.229	Pass
Vertical	5720.000	18.693	34.374	53.067	-57.733	110.800	Pass
Vertical	5725.000	18.711	37.612	56.323	-65.877	122.200	Pass
Vertical	5774.493	18.868	74.264	93.131	--	--	--
Vertical	5850.000	19.103	32.563	51.666	-70.534	122.200	Pass
Vertical	5855.000	19.115	32.485	51.601	-59.199	110.800	Pass
Vertical	5870.145	19.159	33.261	52.421	-54.138	106.559	Pass
Vertical	5875.000	19.177	32.074	51.251	-53.949	105.200	Pass
Vertical	5925.000	19.333	30.953	50.285	-17.915	68.220	Pass
Vertical	5944.348	19.386	33.760	53.146	-15.074	68.220	Pass

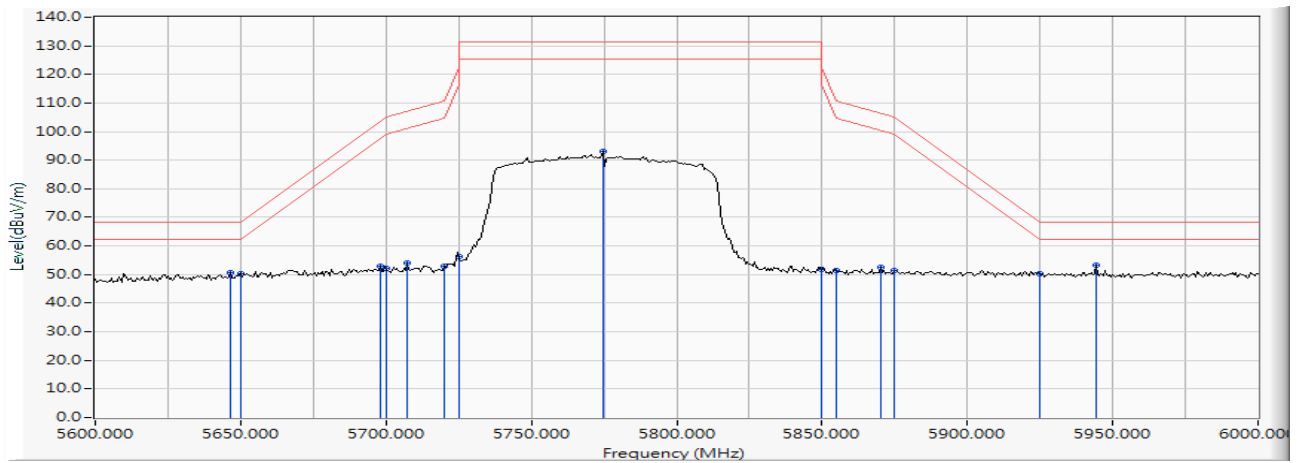

7. Occupied Bandwidth

7.1. Test Setup

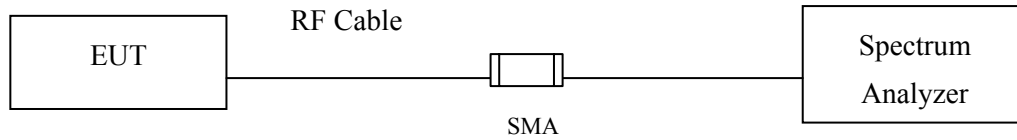

7.2. Limits

For the 5.725-5.85 GHz band, the minimum 6 dB bandwidth of U-NII devices shall be at least 500 kHz

7.3. Test Procedure

The EUT was setup to ANSI C63.10, 2013; tested to UNII test procedure of FCC KDB-789033 for compliance to FCC 47CFR Subpart E requirements.

7.4. Uncertainty

$\pm 671.83\text{Hz}$

7.5. Test Result of Occupied Bandwidth

Product : Automotive Radio with Navigation
 Test Item : Occupied Bandwidth Data
 Test Mode : Mode 1: Transmit (802.11a-6Mbps)
 Test Date : 2017/04/24

Channel No.	Frequency (MHz)	Measurement Level (kHz)	Required Limit (kHz)	Result
149	5745	14800	>500	Pass
157	5785	16400	>500	Pass
165	5825	15900	>500	Pass

Figure Channel 149:

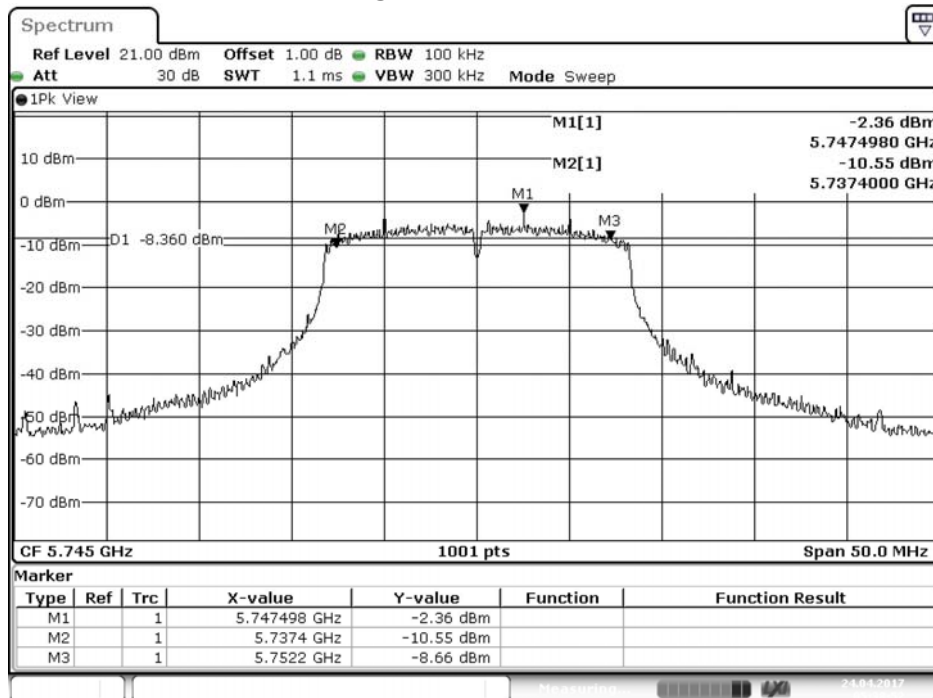

Date: 24.APR.2017 05:38:53

Figure Channel 157:

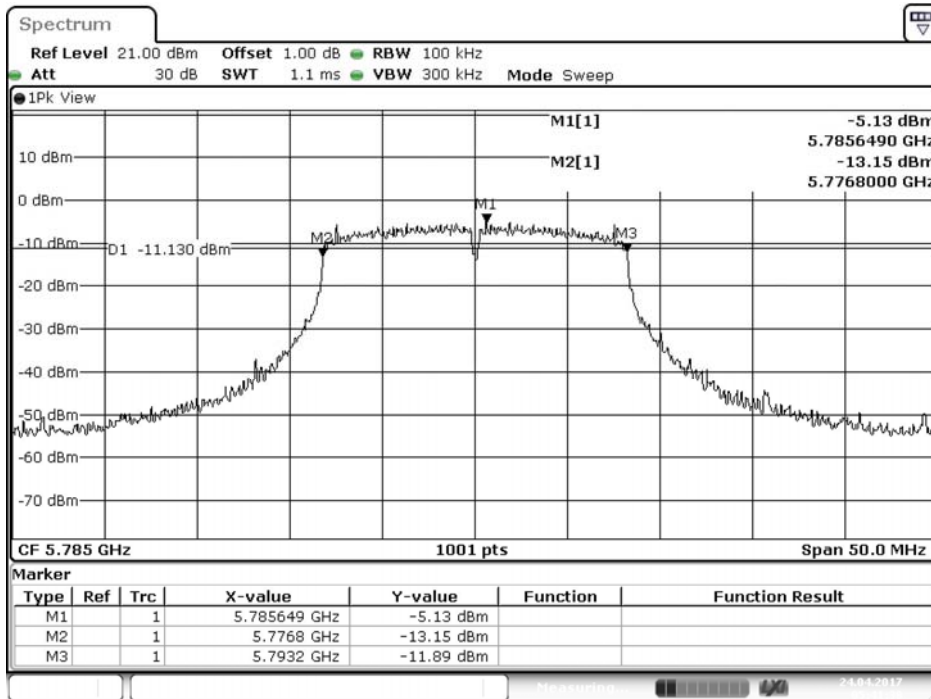

Date: 24.APR.2017 05:41:39

Figure Channel 165:

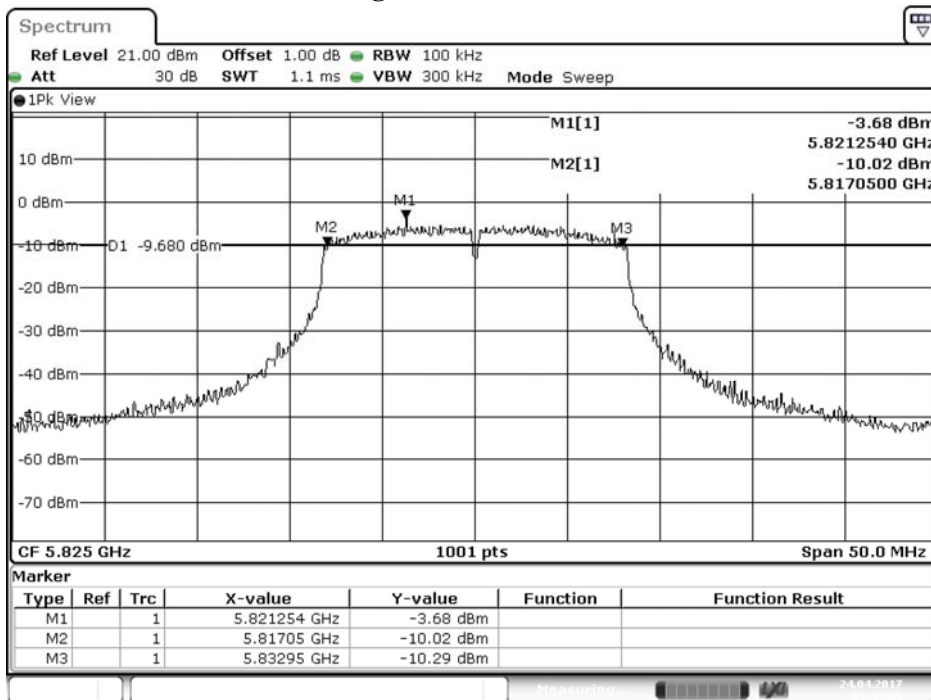

Date: 24.APR.2017 05:43:09

Product : Automotive Radio with Navigation
 Test Item : Occupied Bandwidth Data
 Test Mode : Mode 2: Transmit (802.11n-20BW 7.2Mbps)
 Test Date : 2017/04/24

Channel No.	Frequency (MHz)	Measurement Level (kHz)	Required Limit (kHz)	Result
149	5745	15150	>500	Pass
157	5785	17600	>500	Pass
165	5825	15150	>500	Pass

Figure Channel 149:

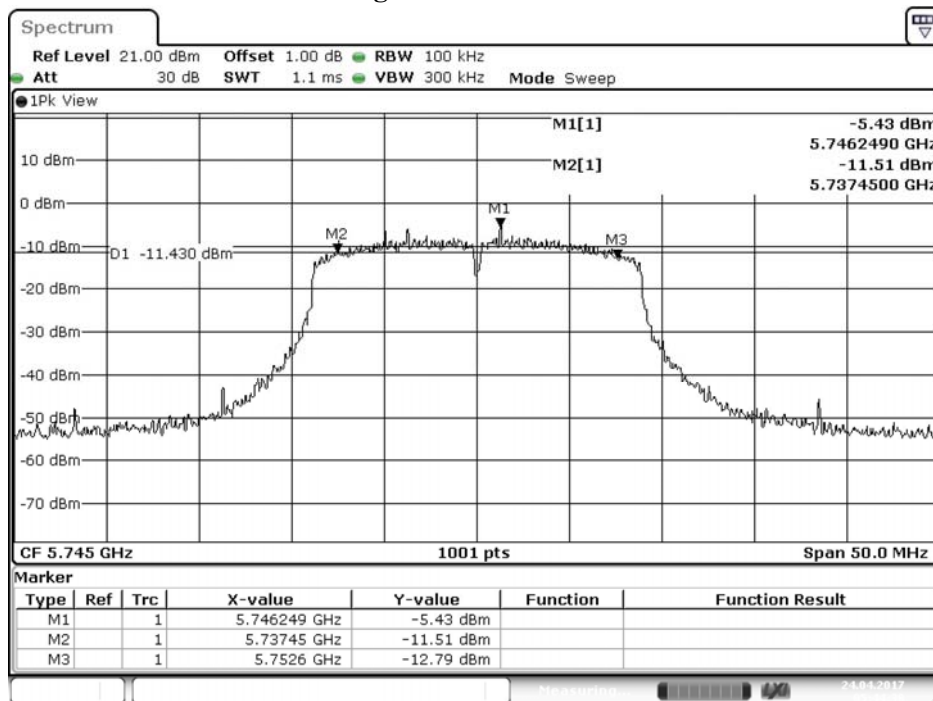

Date: 24.APR.2017 05:44:38

Figure Channel 157:

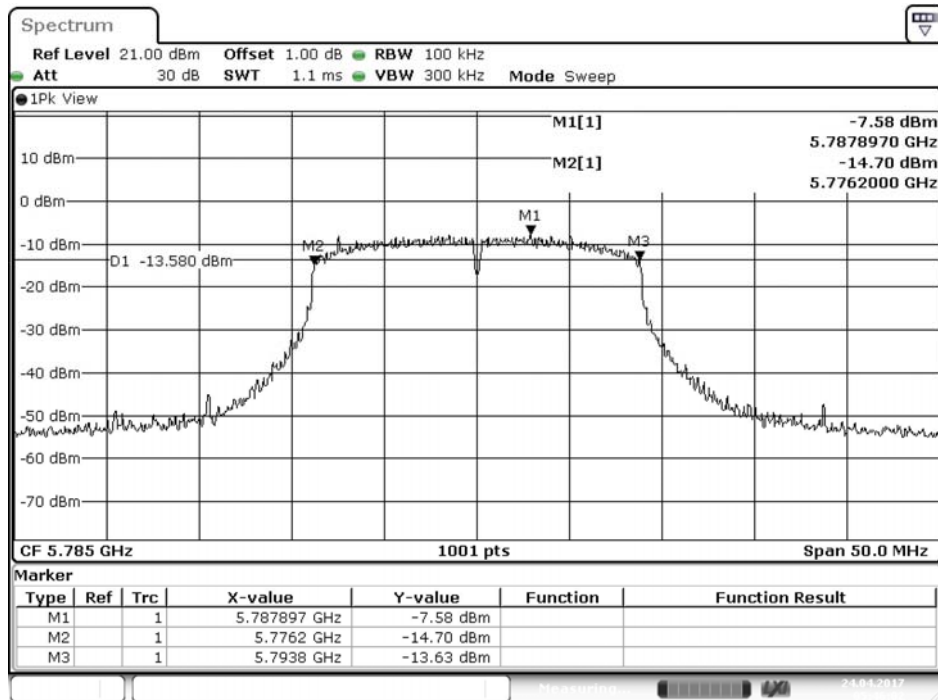

Date: 24.APR.2017 05:46:02

Figure Channel 165:

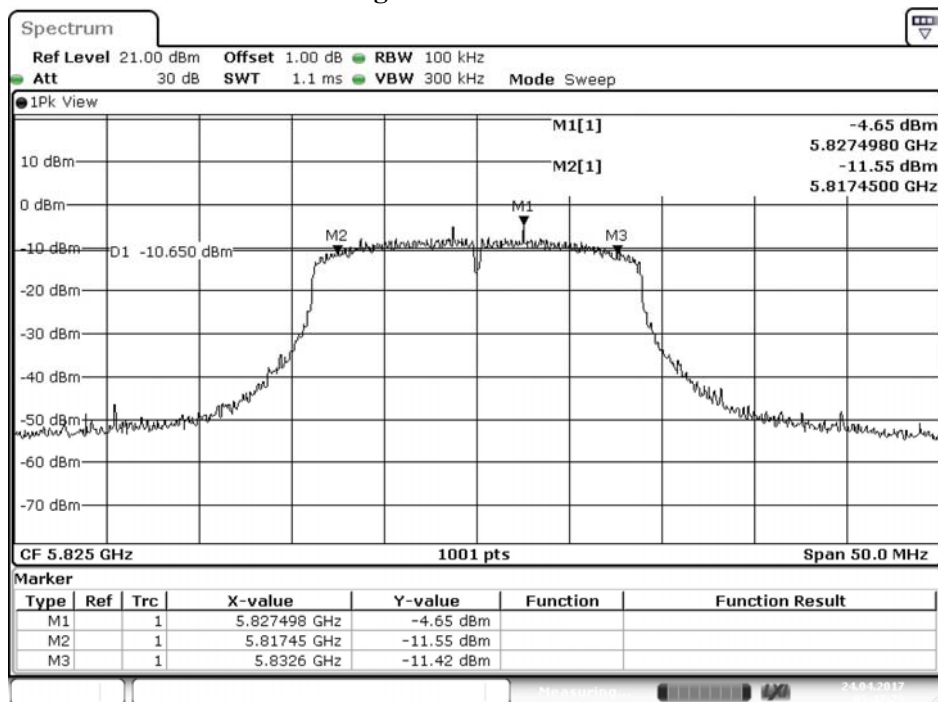

Date: 24.APR.2017 05:47:23

Product : Automotive Radio with Navigation
 Test Item : Occupied Bandwidth Data
 Test Mode : Mode 3: Transmit (802.11n-40BW 15Mbps)
 Test Date : 2017/04/24

Channel No.	Frequency (MHz)	Measurement Level (kHz)	Required Limit (kHz)	Result
151	5755	35300	>500	Pass
159	5795	35300	>500	Pass

Figure Channel 151:

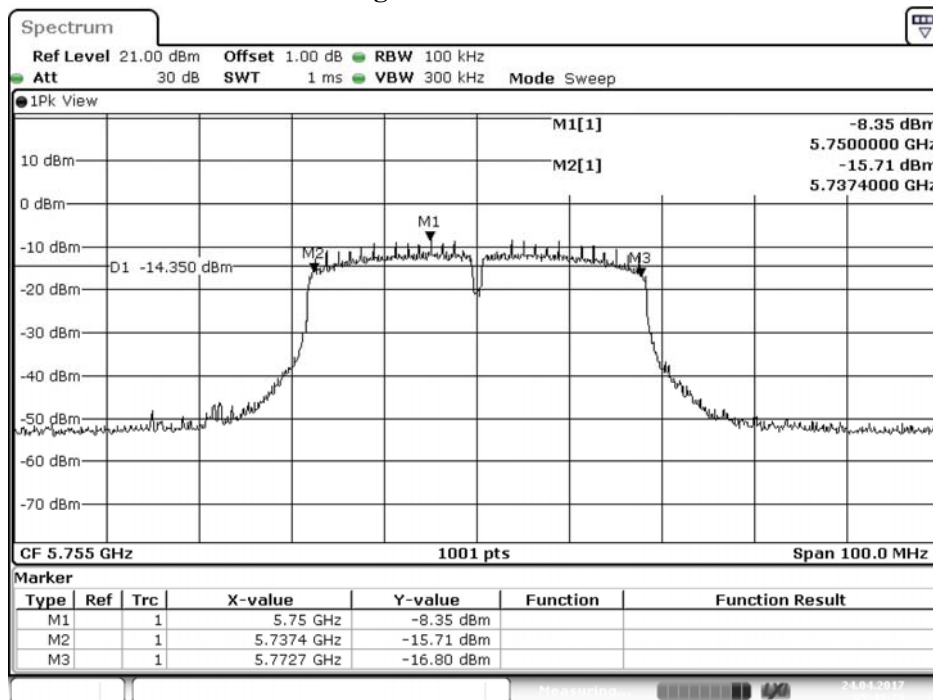

Date: 24.APR.2017 05:49:23

Figure Channel 159:

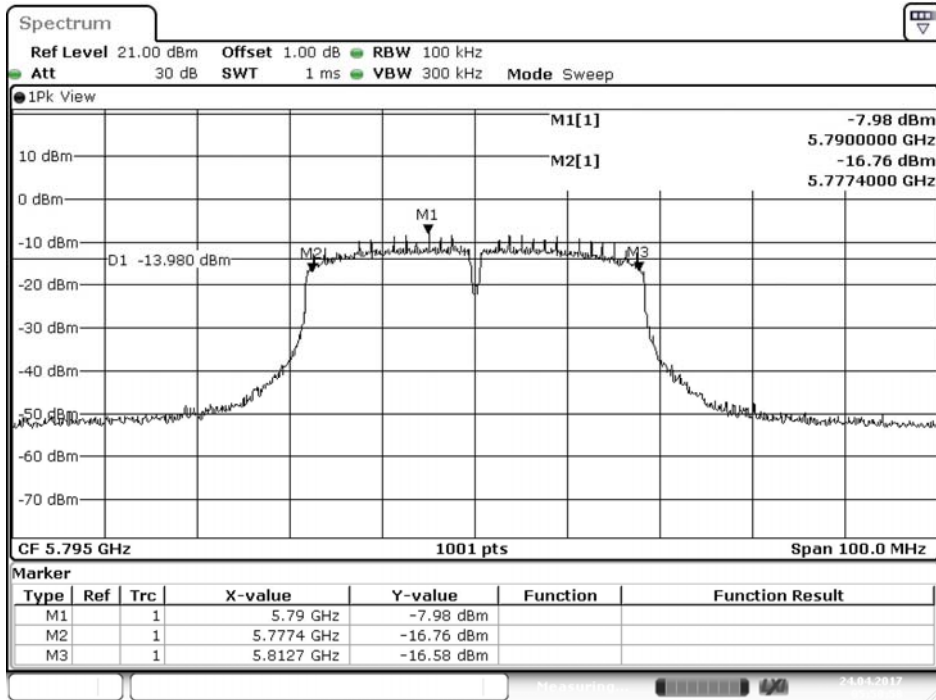

Date: 24.APR.2017 05:50:58

Product : Automotive Radio with Navigation
 Test Item : Occupied Bandwidth Data
 Test Mode : Mode 4: Transmit (802.11ac-80BW-32.5Mbps)
 Test Date : 2017/04/24

Channel No.	Frequency (MHz)	Measurement Level (kHz)	Required Limit (kHz)	Result
155	5775	75300	>500	Pass

Figure Channel 155:

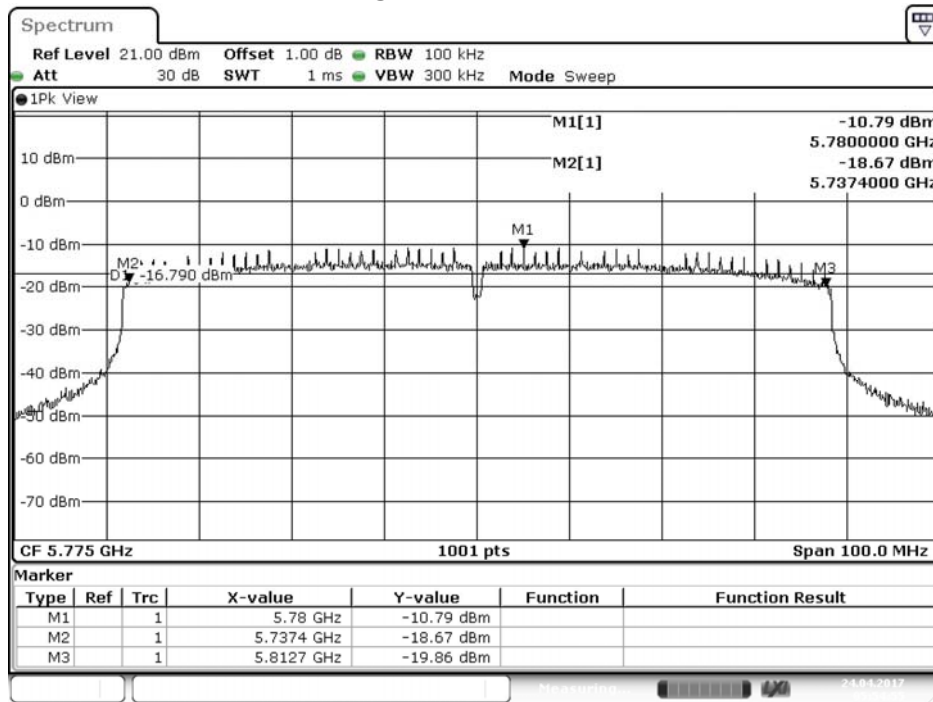

Date: 24.APR.2017 05:54:55

8. Frequency Stability

8.1. Test Setup

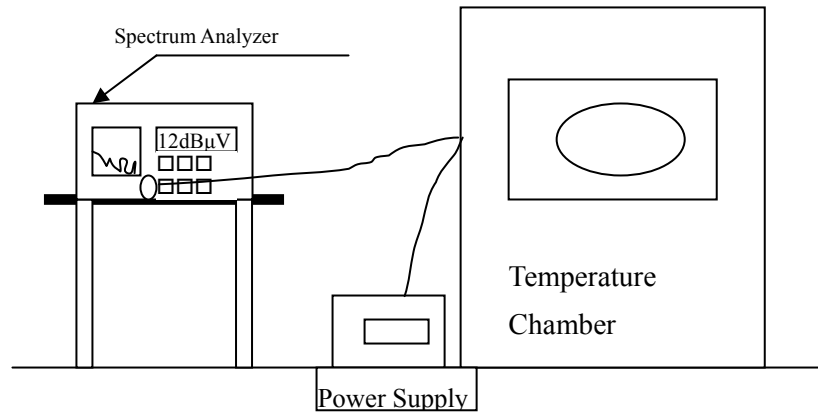

8.2. Limits

Manufacturers of U-NII devices are responsible for ensuring frequency stability such that an emission is maintained within the band of operation under all conditions of normal operation as specified

8.3. Test Procedure

The EUT was setup to ANSI C63.10, 2013; tested to UNII test procedure of FCC KDB-789033 for compliance to FCC 47CFR Subpart E requirements.

8.4. Uncertainty

$\pm 671.83\text{Hz}$

8.5. Test Result of Frequency Stability

Product : Automotive Radio with Navigation
 Test Item : Frequency Stability
 Test Mode : Carrier Wave
 Test Date : 2017/04/22

Test Conditions		Channel	Frequency (MHz)	Frequency (MHz)	ΔF (MHz)
Tnom (20)°C	Vnom (12)V	149	5745.0000	5745.0023	-0.0023
		151	5755.0000	5755.0041	-0.0041
		157	5785.0000	5785.0065	-0.0065
		159	5795.0000	5795.0025	-0.0025
		165	5825.0000	5825.0087	-0.0087
		155	5775.0000	5745.0023	-0.0023
Test Conditions		Channel	Frequency (MHz)	Frequency (MHz)	ΔF (MHz)
Tmax (50)°C	Vmax (13.8)V	149	5745.0000	5745.0059	-0.0059
		151	5755.0000	5755.0068	-0.0068
		157	5785.0000	5785.0015	-0.0015
		159	5795.0000	5795.0034	-0.0034
		165	5825.0000	5825.0058	-0.0058
		155	5775.0000	5745.0059	-0.0059
Test Conditions		Channel	Frequency (MHz)	Frequency (MHz)	ΔF (MHz)
Tmax (50)°C	Vmin (10.2)V	149	5745.0000	5745.0038	-0.0038
		151	5755.0000	5755.0018	-0.0018
		157	5785.0000	5785.0027	-0.0027
		159	5795.0000	5795.0051	-0.0051
		165	5825.0000	5825.0062	-0.0062
		155	5775.0000	5745.0038	-0.0038
Test Conditions		Channel	Frequency (MHz)	Frequency (MHz)	ΔF (MHz)
Tmin (-30)°C	Vmax (13.8)V	149	5745.0000	5745.0039	-0.0039
		151	5755.0000	5755.0099	-0.0099
		157	5785.0000	5785.0064	-0.0064
		159	5795.0000	5795.0076	-0.0076
		165	5825.0000	5825.0092	-0.0092
		155	5775.0000	5745.0039	-0.0039
Test Conditions		Channel	Frequency (MHz)	Frequency (MHz)	ΔF (MHz)
Tmin (-30)°C	Vmin (10.2)V	149	5745.0000	5745.0039	-0.0039
		151	5755.0000	5755.0099	-0.0099
		157	5785.0000	5785.0064	-0.0064
		159	5795.0000	5795.0076	-0.0076
		165	5825.0000	5825.0092	-0.0092
		155	5775.0000	5745.0039	-0.0039

9. EMI Reduction Method During Compliance Testing

No modification was made during testing.

Attachment 1: EUT Test Photographs

Attachment 2: EUT Detailed Photographs