



Valued Quality. Delivered.

TEST REPORT

Report Number: 16110426HKG-001

Application
for
Original Grant of 47 CFR Part 15 Certification
New Family of RSS-247 Issue 1 Equipment Certification

Captioning Phone

FCC ID: ACEENSEMBLE-CC

IC: 1186C-ENSEMBCC

Prepared and Checked by:

Signed On File
Yao Xin Lu, Josie
Engineer

Approved by:

Digitally signed
by Jess Tang
Location:
Intertek Testing
Services Hong
Kong Ltd.

Jess Tang
Lead Engineer
December 23, 2016

- Intertek's standard Terms and Conditions can be obtained at our website: <http://www.intertek.com/terms/>.
- The test report only allows to be revised within the retention period unless further standard or the requirement was noticed.
- This report is for the exclusive use of Intertek's Client and is provided pursuant to the agreement between Intertek and its Client. Intertek's responsibility and liability are limited to the terms and conditions of the agreement. Intertek assumes no liability to any party, other than to the Client in accordance with the agreement, for any loss, expense or damage occasioned by the use of this report. Only the Client is authorized to permit copying or distribution of this report and then only in its entirety. Any use of the Intertek name or one of its marks for the sale or advertisement of the tested material, product or service must first be approved in writing by Intertek. The observations and test results in this report are relevant only to the sample tested. This report by itself does not imply that the material, product, or service is or has ever been under an Intertek certification program.
- © 2016 Intertek

Intertek Testing Services Hong Kong Ltd.

2/F., Garment Centre, 576 Castle Peak Road, Kowloon, Hong Kong.
Tel: (852) 2173 8888 Fax: (852) 2785 5487 Website: www.hk.intertek-etlsemko.com

INTERTEK TESTING SERVICES

GENERAL INFORMATION

Applicant Name:	Clarity, A Division of Plantronics, Inc.
Applicant Address:	6131 Preservation Drive, Chattanooga, TN 37416, United States
FCC Specification Standard:	FCC Part 15, October 1, 2015 Edition
FCC ID:	ACEENSEMBLE-CC
FCC Model(s):	ENSEMBLE-CC
IC Specification Standard:	RSS-247 Issue 1, May 2015 RSS-Gen Issue 4, December 2014
IC:	1186C-ENSEMBCC
PMN:	Ensemble
HVIN:	ENSEMBLE-CC
Type of EUT:	Spread Spectrum Transmitter
Description of EUT:	Captioning Phone
Serial Number:	N/A
Sample Receipt Date:	November 09, 2016
Date of Test:	November 16, 2016
Report Date:	December 23, 2016
Environmental Conditions:	Temperature: +10 to 40°C Humidity: 10 to 90%

INTERTEK TESTING SERVICES

Table of Contents

1.0 Test Results Summary & Statement of Compliance	4
1.1 Summary of Test Results	4
1.2 Statement of Compliance	4
2.0 General Description	6
2.1 Product Description	6
2.2 Test Methodology	6
2.3 Test Facility	6
2.4 Related Submittal(s) Grants	6
3.0 System Test Configuration	8
3.1 Justification	8
3.2 EUT Exercising Software	9
3.3 Details of EUT and Description of Accessories	10
3.4 Measurement Uncertainty	10
4.0 Test Results	12
4.1 Maximum Conducted Output Power at Antenna Terminals	12
4.2 Minimum 6dB RF Bandwidth	23
4.3 Maximum Power Spectral Density	28
4.4 Out of Band Conducted Emissions	33
4.5 Field Strength Calculation	40
4.6 Transmitter Radiated Emissions in Restricted Bands and Spurious Emissions	41
4.6.1 Radiated Emission Configuration Photograph	41
4.6.2 Radiated Emission Data	41
4.6.3 Radiated Emission Test Setup	50
4.6.4 Transmitter Duty Cycle Calculation	51
4.7 AC Power Line Conducted Emission	52
4.7.1 AC Power Line Conducted Emission Configuration Photograph	52
4.7.2 AC Power Line Conducted Emission Data	52
4.7.3 Conducted Emission Test Setup	56
5.0 Equipment List	58

INTERTEK TESTING SERVICES

**EXHIBIT 1
TEST RESULTS SUMMARY & STATEMENT OF COMPLIANCE**

INTERTEK TESTING SERVICES

1.0 Test Results Summary & Statement of Compliance

1.1 Summary of Test Results

Test Items	FCC Part 15 Section	RSS-247/ RSS-Gen# Section	Results	Details see section
Antenna Requirement	15.203	8.3#	Pass	2.1
Max. Conducted Output Power (average)	15.247(b)(3)&(4)	5.4(4)	Pass	4.1
Min. 6dB RF Bandwidth	15.247(a)(2)	5.2(1)	Pass	4.2
Max. Power Density (average)	15.247(e)	5.2(2)	Pass	4.3
Out of Band Antenna Conducted Emission	15.247(d)	5.5	Pass	4.4
Radiated Emission in Restricted Bands and Spurious Emissions	15.247(d), 15.209 & 15.109	5.5	Pass	4.6
AC Power Line Conducted Emission	15.207 & 15.107	8.8#	Pass	4.7

Note: Pursuant to FCC Part 15 Section 15.215(c), the 20dB bandwidth of the emission was contained within the frequency band designated (mentioned as above) which the EUT operated. The effects, if any, from frequency sweeping, frequency hopping, other modulation techniques and frequency stability over expected variations in temperature and supply voltage were considered.

1.2 Statement of Compliance

The equipment under test is found to be complying with the following standard:

FCC Part 15, October 1, 2015 Edition
RSS-247 Issue 1, May 2015
RSS-Gen Issue 4, November 2014

INTERTEK TESTING SERVICES

EXHIBIT 2 GENERAL DESCRIPTION

INTERTEK TESTING SERVICES

2.0 General Description

2.1 Product Description

The ENSEMBLE-CC is a Captioning Phone.

The Equipment Under Test (EUT) operates at frequency range of 2412MHz to 2462MHz with 11 channels. For 802.11b mode, it operates at frequency range of 2412.000MHz to 2462.000MHz with 11 channels. It transmits via Direct-sequence spread spectrum (DSSS) modulation. Maximum bit rate can be up to 11Mbps. For 802.11g mode, it operates at frequency range of 2412.000MHz to 2462.000MHz with 11 channels. It transmits via Orthogonal Frequency Division Multiplexing (OFDM) modulation. Maximum bit rate can be up to 54Mbps.

The EUT is power by a 100-240VAC to 12VDC 1.5A adaptor.

The antenna(s) used in the EUT is integral, and the test sample is a prototype.

The circuit description is saved with filename: descri.pdf.

2.2 Test Methodology

Both AC power line-conducted and radiated emission measurements were performed according to the procedures in ANSI C63.10 (2013). Preliminary radiated scans and all radiated measurements were performed in radiated emission test sites. All Radiated tests were performed at an antenna to EUT distance of 3 meters, unless stated otherwise in the "**Justification Section**" of this Application. Antenna port conducted measurements were performed according to ANSI C63.10 (2013) and KDB Publication No.558074 D01 v03r05 (08-April-2016) All other measurements were made in accordance with the procedures in 47 CFR Part 2 and RSS-Gen Issue 4 (2014).

2.3 Test Facility

The radiated emission test site and antenna port conducted measurement facility used to collect the radiated data and conductive data are at Workshop No. 3, G/F., World-Wide Industrial Centre, 43-47 Shan Mei Street, Fo Tan, Sha Tin, N.T., Hong Kong. This test facility and site measurement data have been fully placed on file with the FCC and Industry Canada No.: 2042V-1.

2.4 Related Submittal(s) Grants

This is a single application for certification of a transceiver (WiFi portion)

INTERTEK TESTING SERVICES

**EXHIBIT 3
SYSTEM TEST CONFIGURATION**

INTERTEK TESTING SERVICES

3.0 System Test Configuration

3.1 Justification

For radiated emissions testing, the equipment under test (EUT) was setup to transmit / receive continuously to simplify the measurement methodology. Care was taken to ensure proper power supply voltages during testing. During testing, all cables (if any) were manipulated to produce worst case emissions.

The EUT was powered by a 100-240VAC to 12VDC 1.5A adaptor.

For the measurements, the EUT was attached to a plastic stand if necessary and placed on the wooden turntable. If the base unit attached to peripherals, they were connected and operational (as typical as possible).

The signal was maximized through rotation and placement in the three orthogonal axes. The antenna height and polarization were varied during the search for maximum signal level. The antenna height was varied from 1 to 4 meters. Radiated emissions were taken at three meters unless the signal level was too low for measurement at that distance. If necessary, a pre-amplifier was used and/or the test was conducted at a closer distance.

For any intentional radiator powered by AC power line, measurements of the radiated signal level of the fundamental frequency component of the emission was performed with the supply voltage varied between 85% and 115% of the nominal rated supply voltage.

Radiated emission measurement for transmitter were performed from the lowest radio frequency signal generated in the device which is greater than 9 kHz to the tenth harmonic of the highest fundamental frequency or to 40 GHz, whichever is lower.

Emission that are directly caused by digital circuits in the transmit path and transmitter portion were measured, and the limit are according to FCC Part 15 Section 15.209. Digital circuitries used to control additional functions other than the operation of the transmitter are subject to FCC Part 15 Section 15.109.

INTERTEK TESTING SERVICES

3.1 Justification – Cont'd

Detector function for radiated emissions was in peak mode. Average readings, when required, were taken by measuring the duty cycle of the equipment under test and subtracting the corresponding amount in dB from the measured peak readings. A detailed description for the calculation of the average factor can be found in section 4.8.3.

Determination of pulse desensitization was made according to *Hewlett Packard Application Note 150-2, Spectrum Analysis... Pulsed RF*. The effective period (Teff) was referred to Exhibit 4.8.3. With the resolution bandwidth 1MHz and spectrum analyzer IF bandwidth 3dB, the pulse desensitization factor was 0dB.

For AC line conducted emission test, the EUT along with its peripherals were placed on a 1.0m(W)x1.5m(L) and 0.8m in height wooden table and the EUT was adjusted to maintain a 0.4 meter space from a vertical reference plane. The EUT was connected to power mains through a line impedance stabilization network (LISN), which provided 50ohm coupling impedance for measuring instrument. The LISN housing, measuring instrument case, reference ground plane, and vertical ground plane were bounded together. The excess power cable between the EUT and the LISN was bundled.

All connecting cables of EUT and peripherals were manipulated to find the maximum emission.

Different data rates have been tested. Worst case is reported only.

All relevant operation modes have been tested, and the worst case data is included in this report.

All data rates were tested under normal mode of WiFi. Only the worst-case data is shown in the report for DSSS and OFDM

3.2 EUT Exercising Software

The EUT exercise program (if any) used during radiated and conducted testing was designed to exercise the various system components in a manner similar to a typical use.

INTERTEK TESTING SERVICES

3.3 Details of EUT and Description of Accessories

Details of EUT:

An AC adaptor (provided with the unit) was used to power the device. Their description are listed below.

- (1) An AC adaptor (100-240VAC to 12VDC 1.5A, Model: K18V120150U) (Supplied by Client)

Description of Accessories:

- (1) 1 X LAN cable of 1m in length (Supplied by Client)
- (2) 1 X Headset of 1m in length (Provided by Client)
- (3) 1 X Neck Loop, Model: CE30 (Provided by Client)
- (4) 1 X Telephone cable of 2m in length (Provided by Intertek)
- (5) 1 X Telephone Line Simulator, Brand: TELTONE, Model: TLS-5D-01 (Provided by Intertek)
- (6) 1 X Wireless Router, Brand: TP-Link, Model: TL-WDR4300, FCC ID: TE7WDR4300 (Provided by Intertek)

3.4 Measurement Uncertainty

When determining of the test conclusion, the Measurement Uncertainty of test at a level of confidence of 95% has been considered. The values of the Measurement uncertainty for radiated emission test and RF conducted measurement test are $\pm 5.3\text{dB}$ and $\pm 0.99\text{dB}$ respectively. The value of the Measurement uncertainty for conducted emission test is $\pm 4.2\text{dB}$.

Uncertainty and Compliance - Unless the standard specifically states that measured values are to be extended by the measurement uncertainty in determining compliance, all compliance determinations are based on the actual measured value.

INTERTEK TESTING SERVICES

**EXHIBIT 4
TEST RESULTS**

INTERTEK TESTING SERVICES

4.0 Test Results

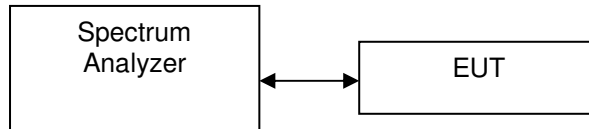

4.1 Maximum Conducted (average) Output Power at Antenna Terminals

The antenna port of the EUT was connected to the input of a spectrum analyzer.

- The antenna power of the EUT was connected to the input of a power meter. Power was read directly and cable loss correction was added to the reading to the obtain power at the EUT antenna terminals. The measurement procedure 9.1.2 was used.
- The EUT should be configured to transmit continuously (at a minimum duty cycle of 98%) at full power over the measurement duration. The measurement procedure AVGSA-1 was used.

Occupied Bandwidth

IEEE 802.11b (DSSS, 1 Mbps)	
Frequency (MHz)	Occupied Bandwidth (MHz)
Low Channel: 2412	13.44
Middle Channel: 2437	13.44
High Channel: 2462	13.38

IEEE 802.11g (OFDM, 6 Mbps)	
Frequency (MHz)	Occupied Bandwidth (MHz)
Low Channel: 2412	16.86
Middle Channel: 2437	16.86
High Channel: 2462	16.80

The plots of occupied bandwidth are saved as below.

Plots of Occupied Bandwidth
802.11b, Lowest Channel

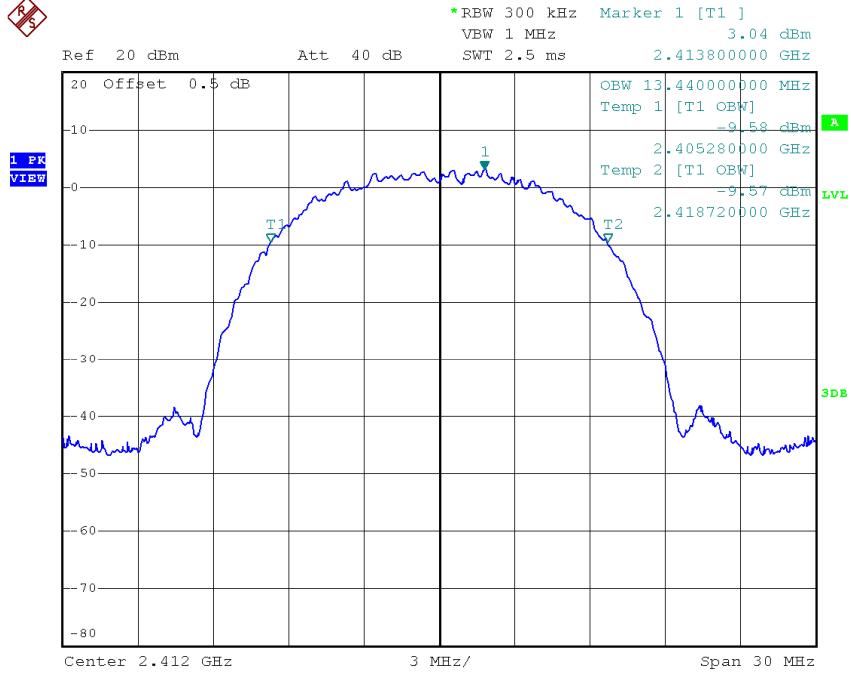

802.11b, Middle Channel

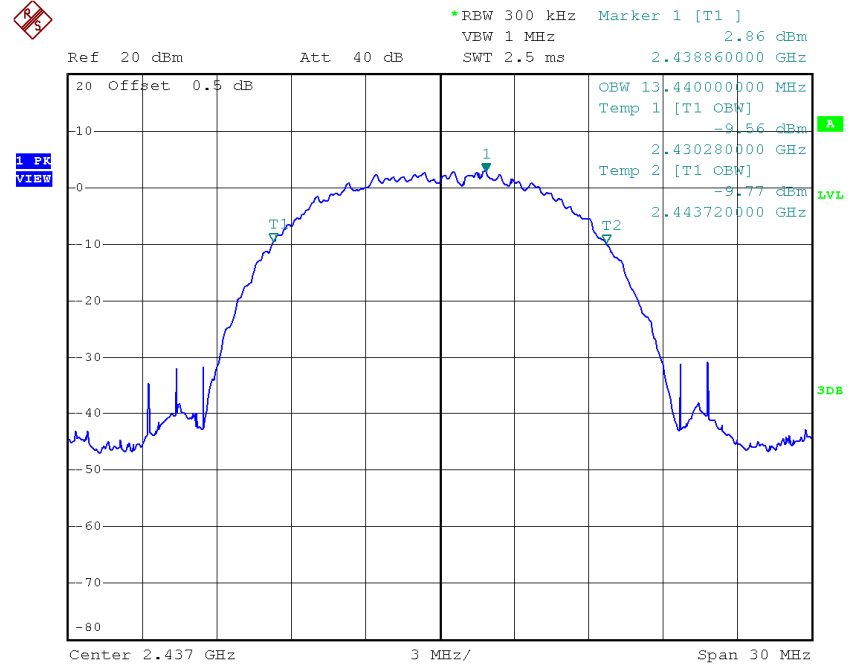

INTERTEK TESTING SERVICES

Plots of Occupied Bandwidth 802.11b, Highest Channel

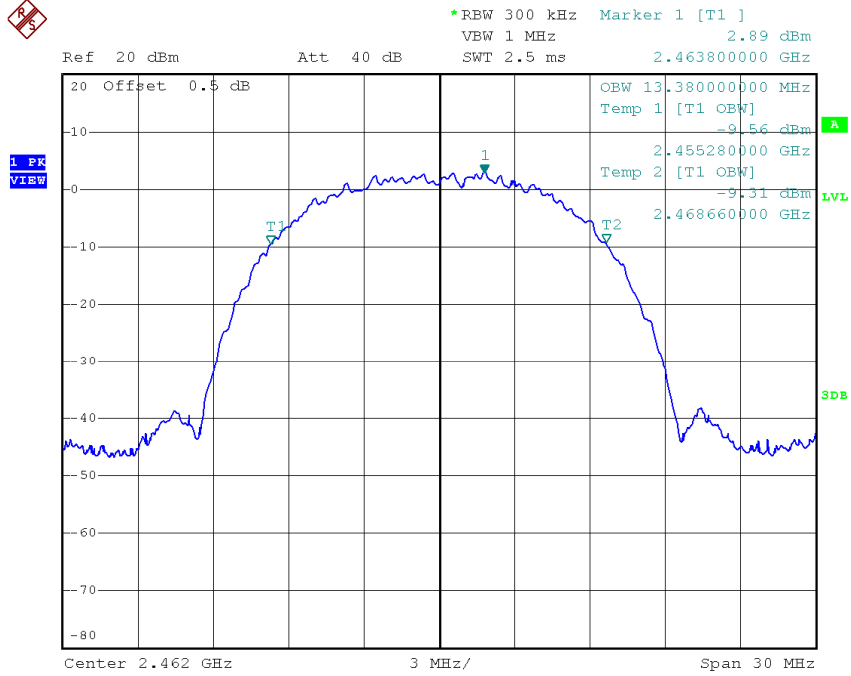

INTERTEK TESTING SERVICES

Plots of Occupied Bandwidth 802.11g, Lowest Channel

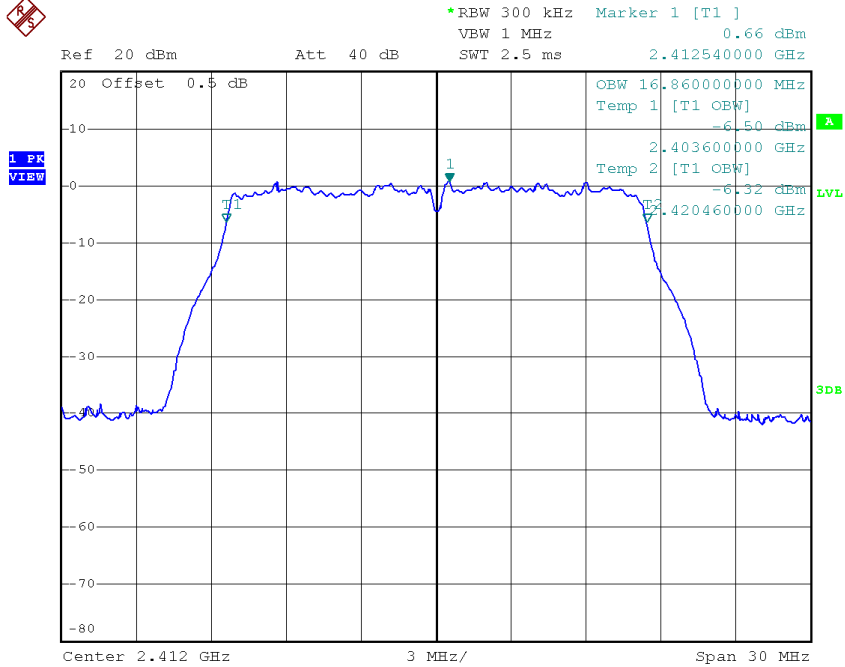

802.11g, Middle Channel

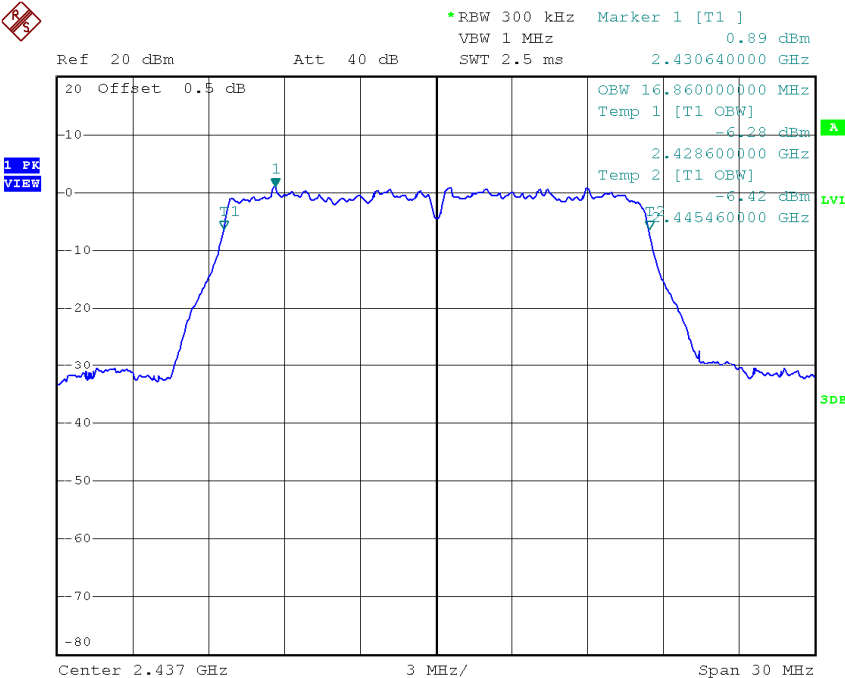

INTERTEK TESTING SERVICES

Plots of Occupied Bandwidth 802.11g, Highest Channel

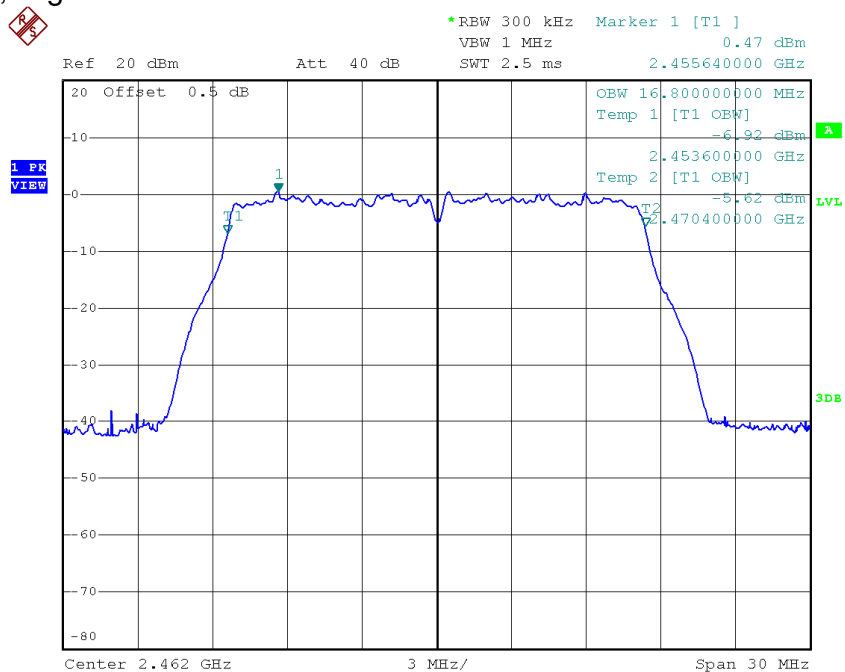

INTERTEK TESTING SERVICES

4.1 Maximum Conducted Output Power at Antenna Terminals – Cont'd

IEEE 802.11b (DSSS, 1 Mbps) Antenna Gain = 0 dBi		
Frequency (MHz)	Output in dBm	Output in mWatt
Low Channel: 2412	12.87	19.364
Middle Channel: 2437	12.86	19.320
High Channel: 2462	12.71	18.664

IEEE 802.11g (OFDM, 6 Mbps) Antenna Gain = 0 dBi		
Frequency (MHz)	Output in dBm	Output in mWatt
Low Channel: 2412	12.06	16.069
Middle Channel: 2437	12.10	16.218
High Channel: 2462	11.43	13.900

INTERTEK TESTING SERVICES

4.1 Maximum Conducted Output Power at Antenna Terminals – Cont'd

Cable loss : 0.5 dB External Attenuation : 0 dB

Cable loss, external attenuation: included in OFFSET function
 added to SA raw reading

IEEE 802.11b (DSSS, 1 Mbps)

max. conducted (average) output level = 12.87 dBm

IEEE 802.11g (OFDM, 9 Mbps)

max. conducted (average) output level = 12.10 dBm

Limits:

1W (30dBm) for antennas with gains of 6dBi or less

___W (___dBm) for antennas with gains more than 6dBi

The plots of conducted output power are saved as below.

INTERTEK TESTING SERVICES

Plots of maximum output power 802.11b, Lowest Channel

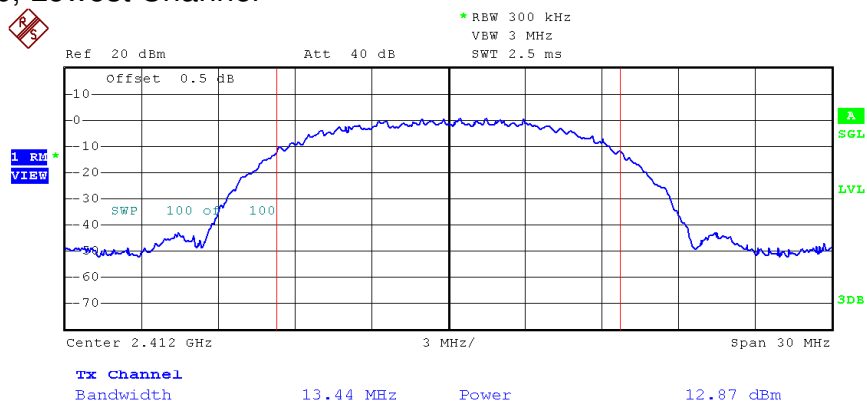

802.11b, Middle Channel

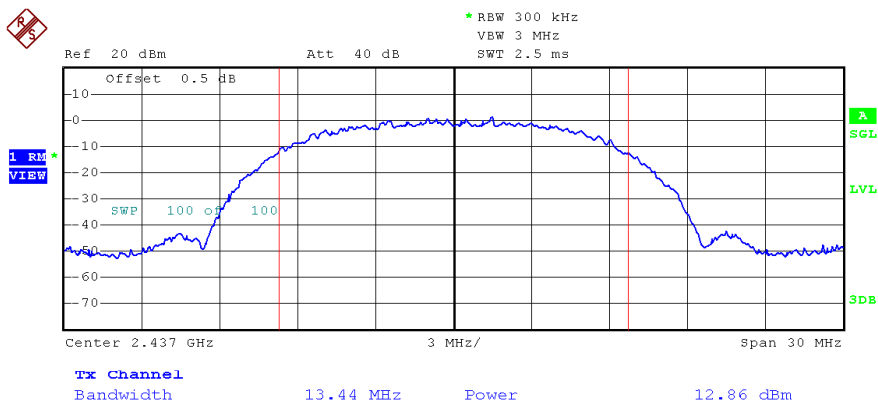

INTERTEK TESTING SERVICES

Plots of maximum output power 802.11b, Highest Channel

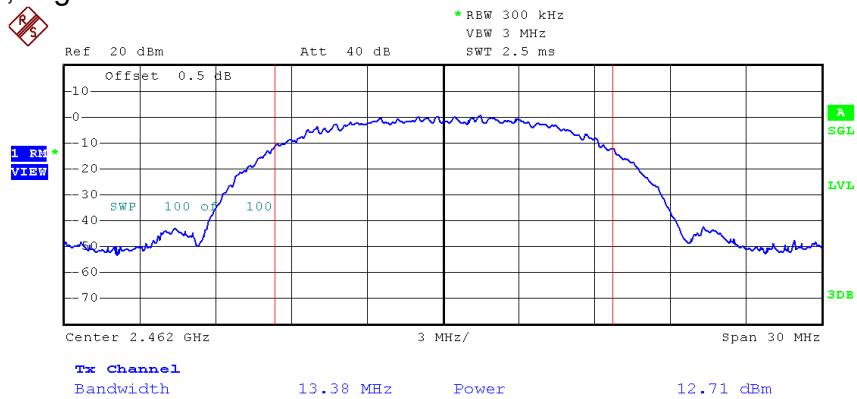

INTERTEK TESTING SERVICES

Plots of maximum output power 802.11g, Lowest Channel

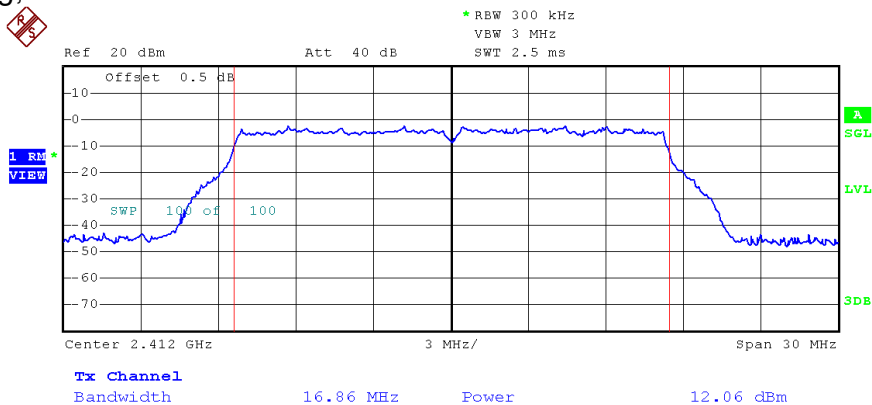

802.11g, Middle Channel

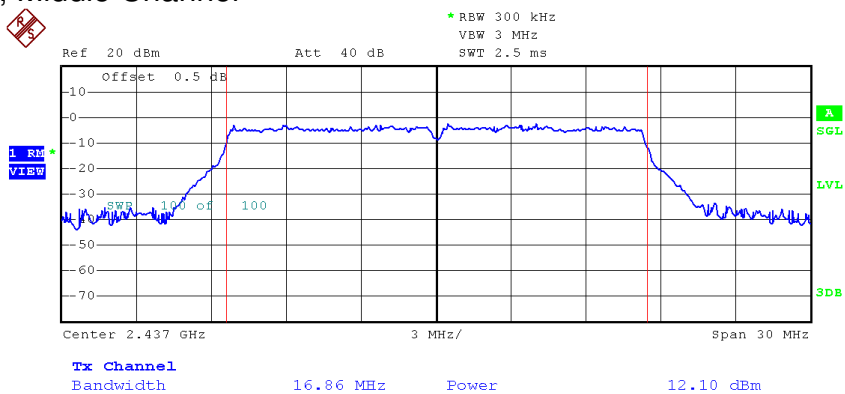

INTERTEK TESTING SERVICES

Plots of maximum output power 802.11g, Highest Channel

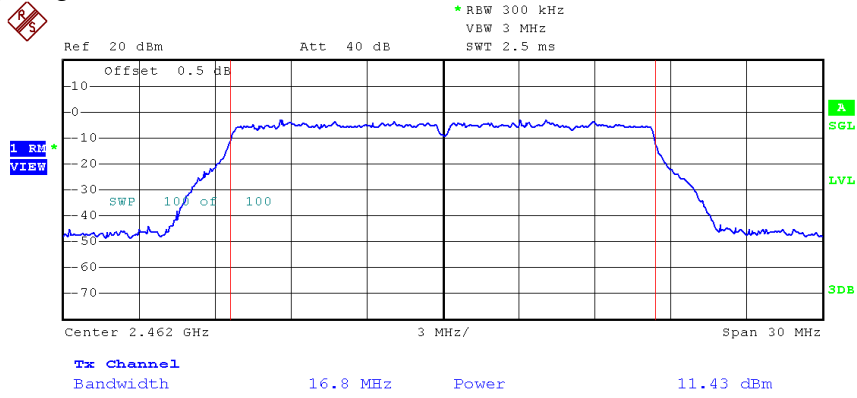

INTERTEK TESTING SERVICES

4.2 Minimum 6dB RF Bandwidth

The antenna port of the EUT was connected to the input of a spectrum analyzer. The EBW measurement procedure was used. A PEAK output reading was taken, a DISPLAY line was drawn 6dB lower than PEAK level. The 6dB bandwidth was determined from where the channel output spectrum intersected the display line.

IEEE 802.11b (DSSS, 1 Mbps)	
Frequency (MHz)	6dB Bandwidth (MHz)
Low Channel: 2412	9.60
Middle Channel: 2437	9.66
High Channel: 2462	9.66

IEEE 802.11g (OFDM, 6 Mbps)	
Frequency (MHz)	6dB Bandwidth (MHz)
Low Channel: 2412	16.68
Middle Channel: 2437	16.68
High Channel: 2462	16.68

Limits

6 dB bandwidth shall be at least 500kHz

The plots of 6dB RF bandwidth are saved as below.

Plots of 6dB RF bandwidth
802.11b, Lowest Channel

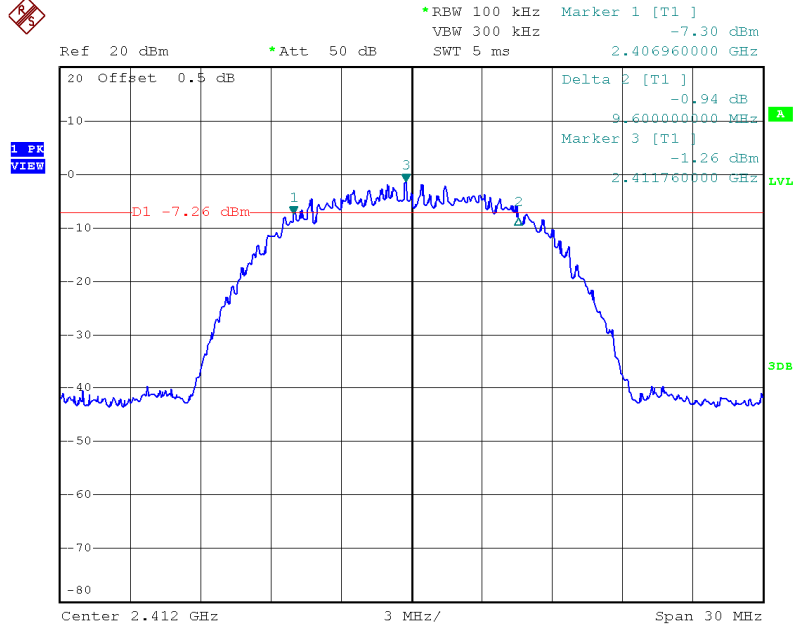

802.11b, Middle Channel

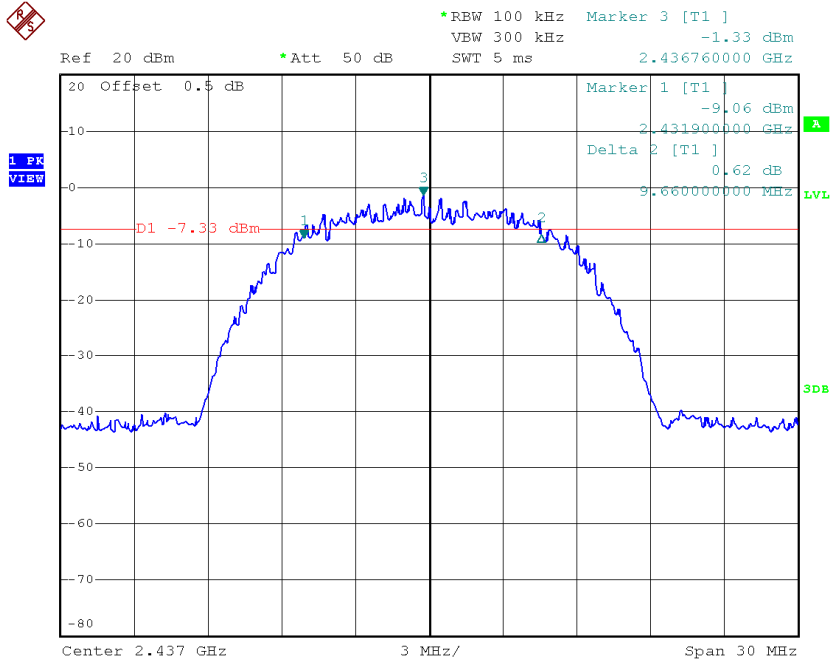

INTERTEK TESTING SERVICES

Plots of 6dB RF bandwidth 802.11b, Highest Channel

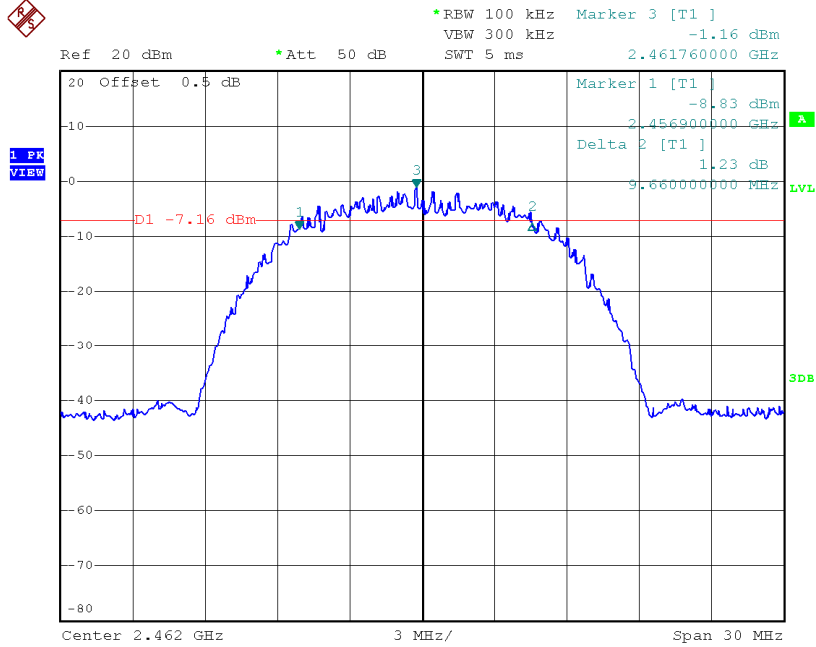

Plots of 6dB RF bandwidth
802.11g, Lowest Channel

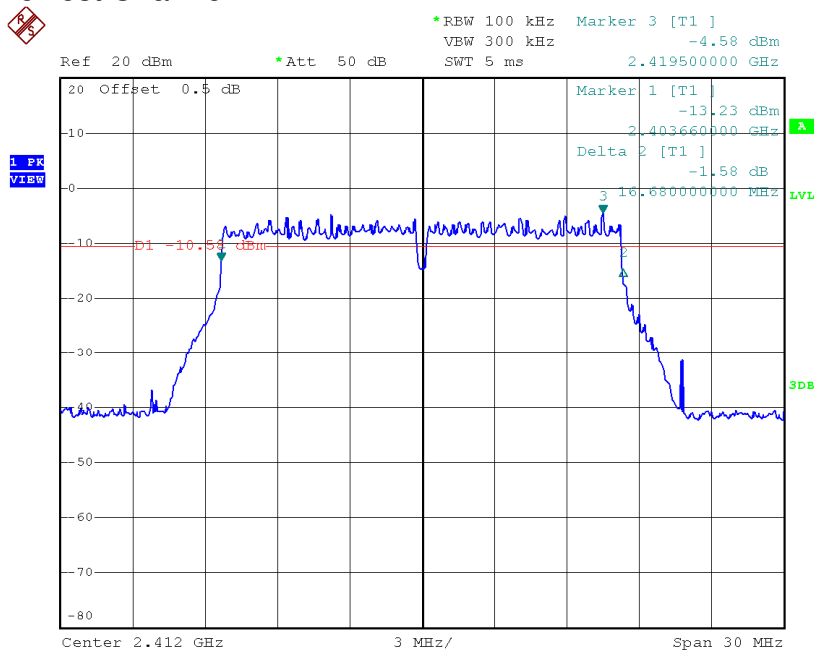

802.11g, Middle Channel

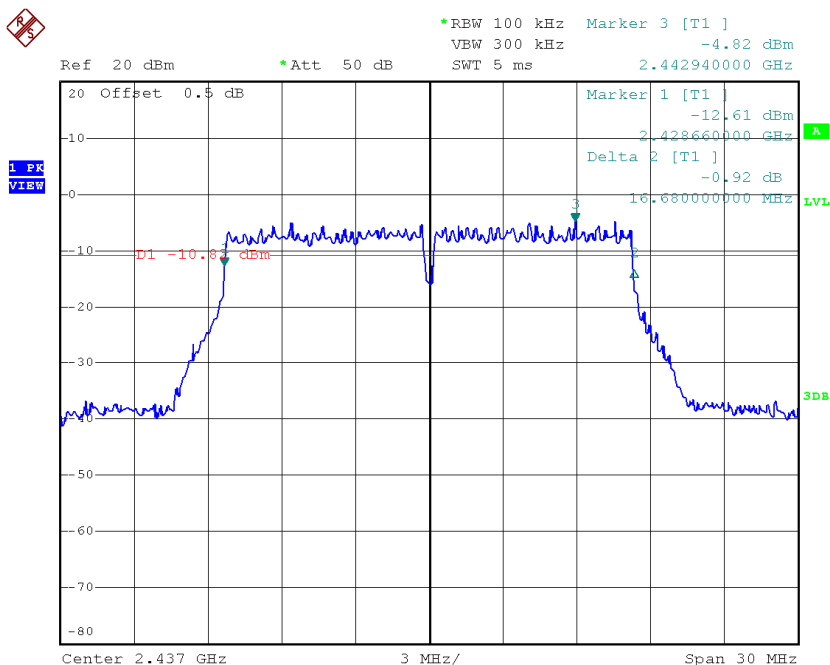

INTERTEK TESTING SERVICES

Plots of 6dB RF bandwidth 802.11g, Highest Channel

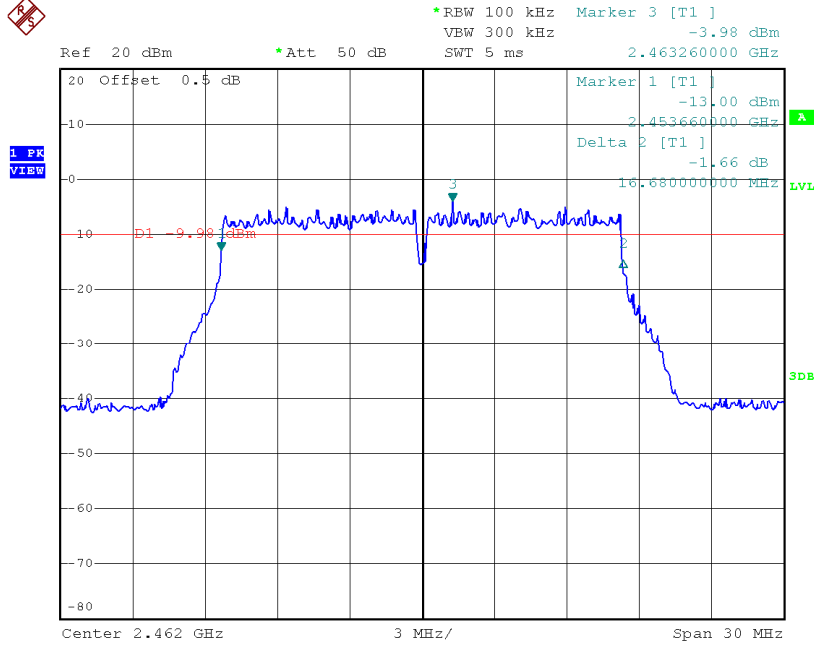

INTERTEK TESTING SERVICES

4.3 Maximum Power Spectral Density

Antenna output of the EUT was coupled directly to spectrum analyzer.

- The measurement procedure 10.2 PKPSD was used.
- The measurement procedure 10.3 AVGPSD was used.

If an external attenuator and/or cable was used, these losses are compensated for using the OFFSET function of the analyser.

IEEE 802.11b (DSSS, 1 Mbps)	
Frequency (MHz)	PSD in 100kHz (dBm)
Low Channel: 2412	-1.66
Middle Channel: 2437	-2.07
High Channel: 2462	-2.28

IEEE 802.11g (OFDM, 6 Mbps)	
Frequency (MHz)	PSD in 100kHz (dBm)
Low Channel: 2412	-6.07
Middle Channel: 2437	-5.58
High Channel: 2462	-5.04

Cable Loss: 0.5 dB

Limit:
8dBm

The plots of power spectral density are as below.

INTERTEK TESTING SERVICES

Plots of power spectral density

802.11b, Lowest channel

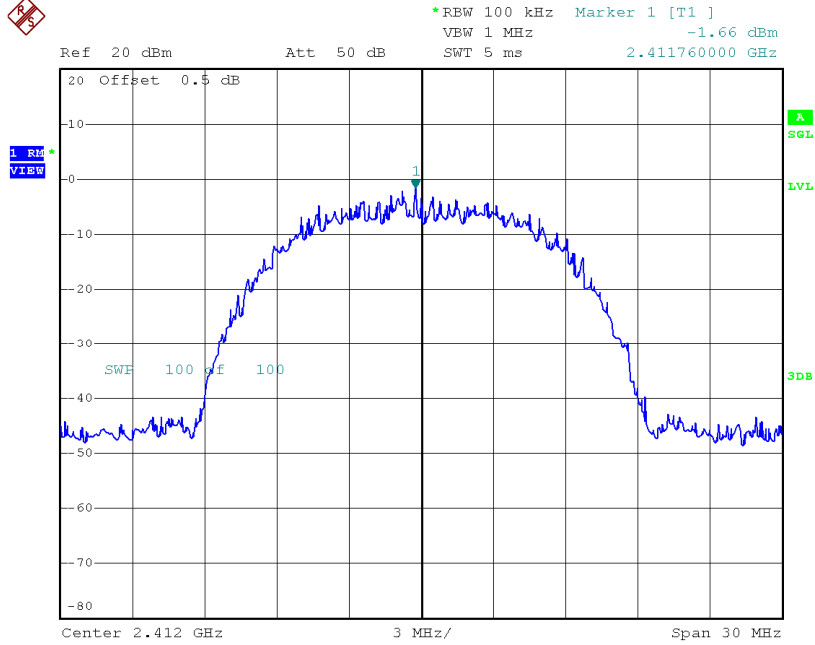

802.11b, Middle channel

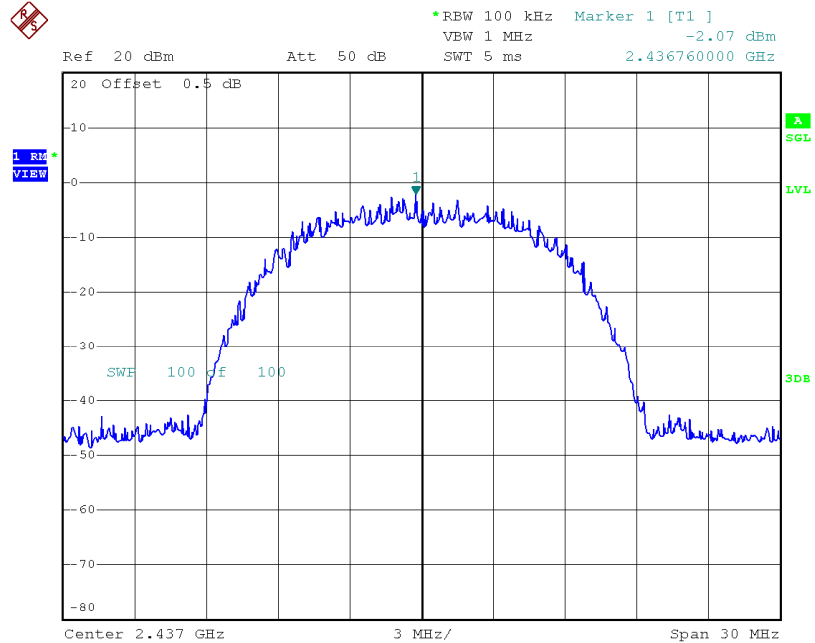

Plots of power spectral density

802.11b, Highest channel

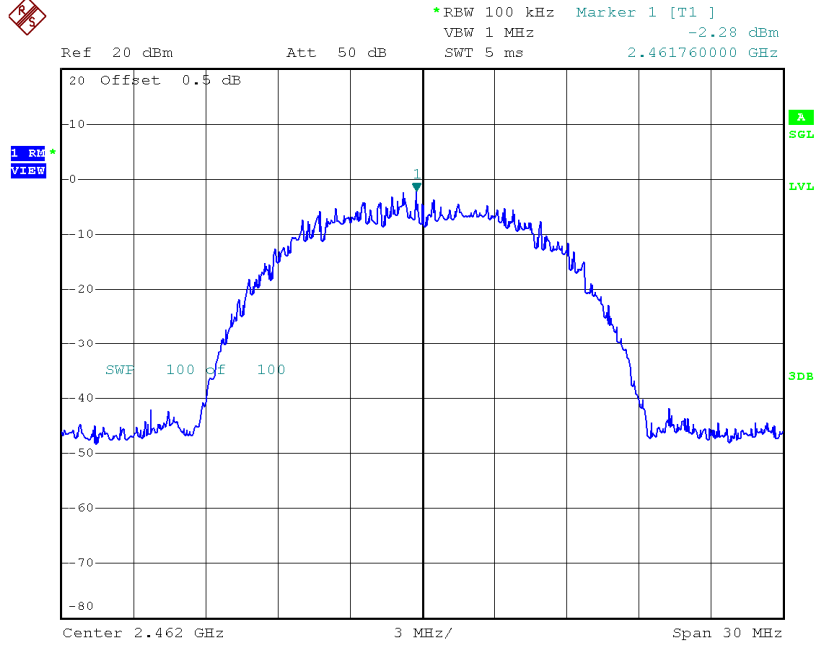

INTERTEK TESTING SERVICES

Plots of power spectral density

802.11g, Lowest channel

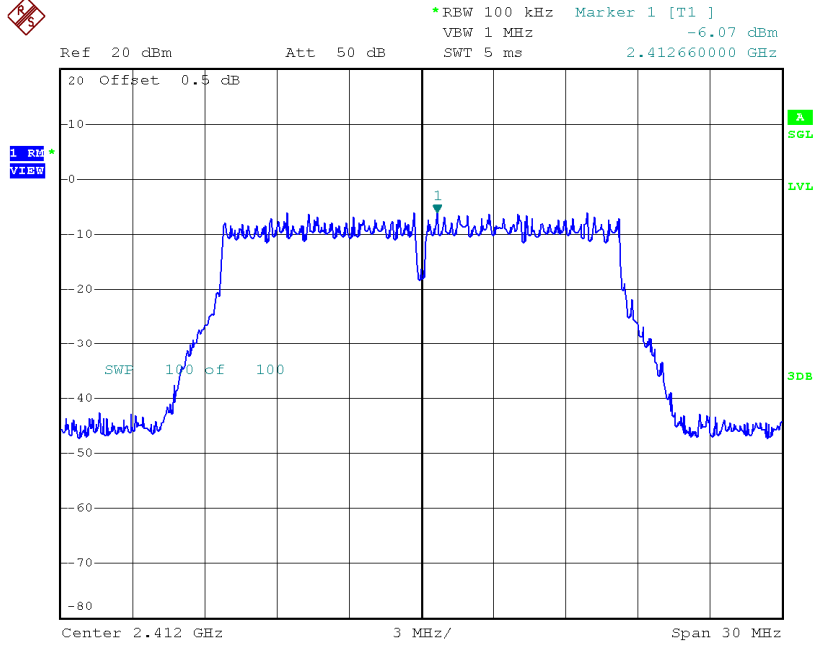

802.11g, Middle channel

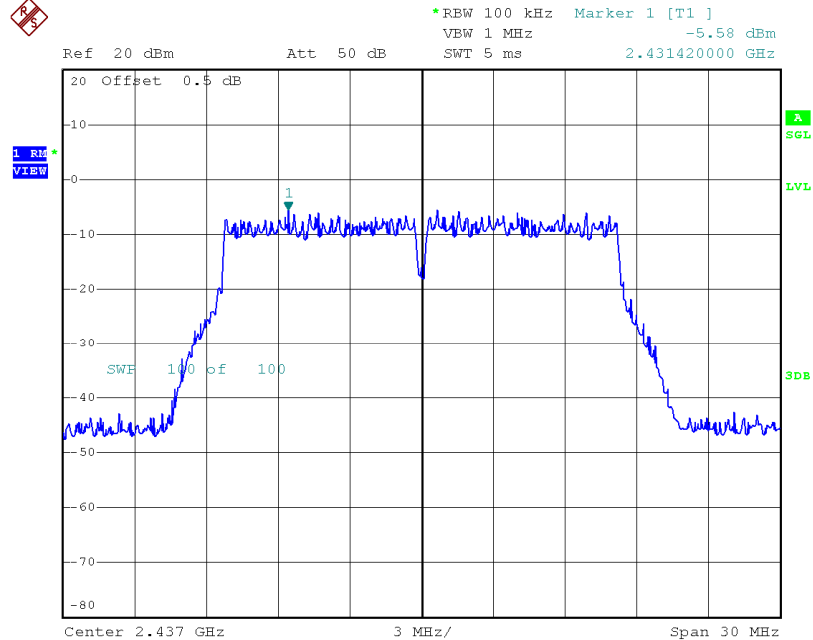

Plots of power spectral density
802.11g, Highest channel

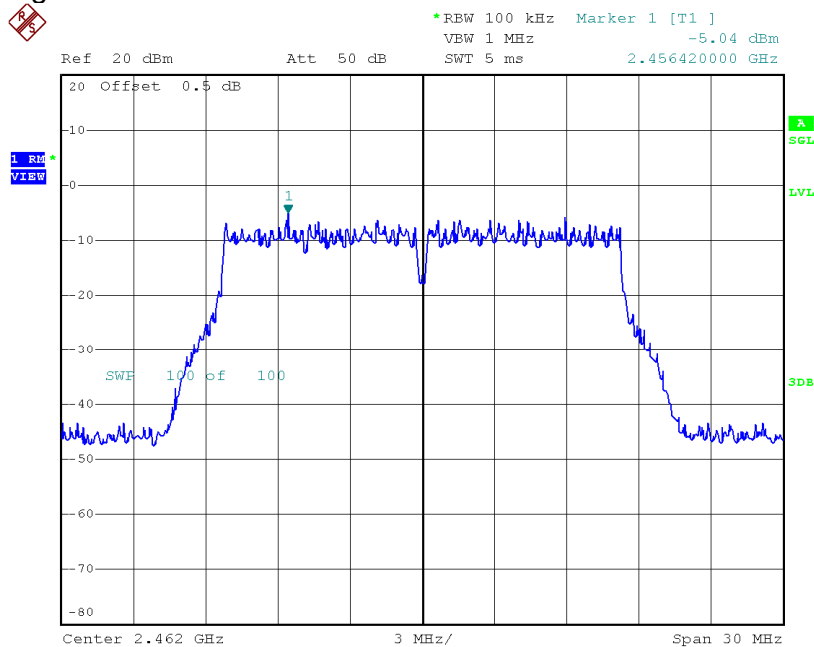

INTERTEK TESTING SERVICES

4.4 Out of Band Conducted Emissions

For 802.11b/g20MHz, the maximum conducted (average) output power was used to demonstrate compliance as described in 9.2. Then the display line (in red) shown in the following plots denotes the limit at 30dB below maximum measured in-band peak PSD level in 100 KHz bandwidth.

The measurement procedures under sections 11 of KDB558074 D01 v03r05 (08-April-2016) were used.

Furthermore, delta measurement technique for measuring bandedge emissions was incorporated in the test of the edge at 2483.5MHz.

Limits:

All spurious emission and up to the tenth harmonic was measured and they were found to be at least 30 dB for 802.11b, g below the maximum measured in-band peak PSD level.

The plots of out of band conducted emissions are as below.

Plots of out of band conducted emissions

802.11b, Lowest Channel, Plot A

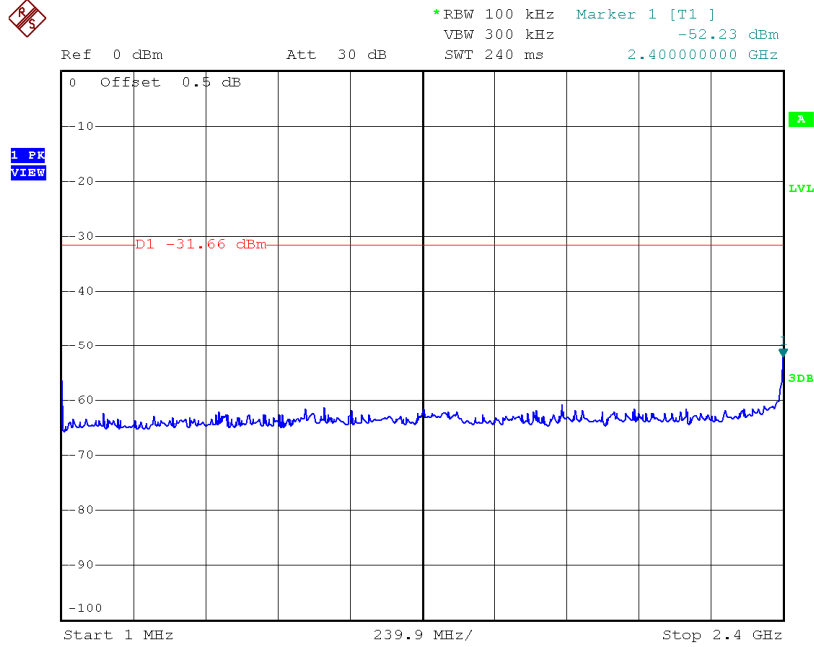

802.11b, Lowest Channel, Plot B

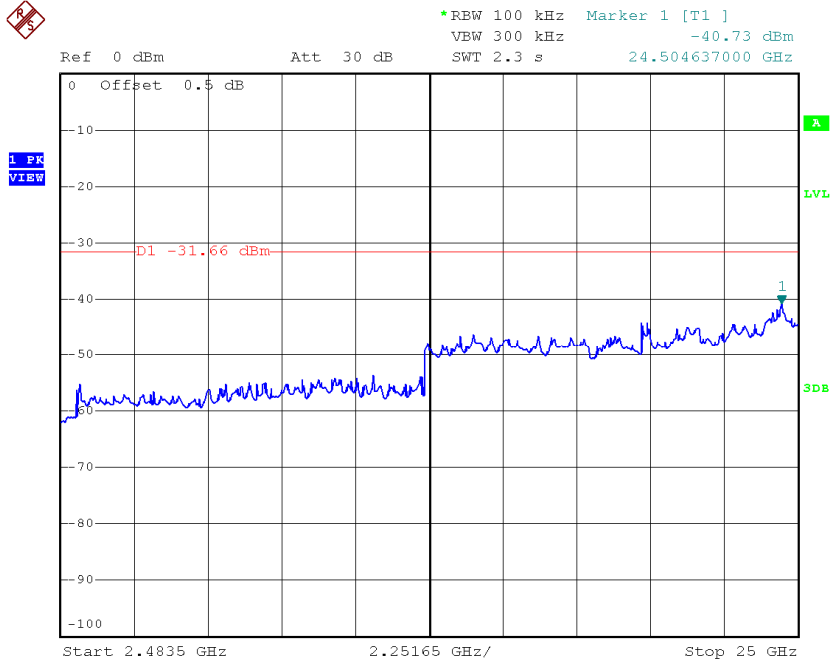

INTERTEK TESTING SERVICES

Plots of out of band conducted emissions

802.11b, Middle Channel, Plot A

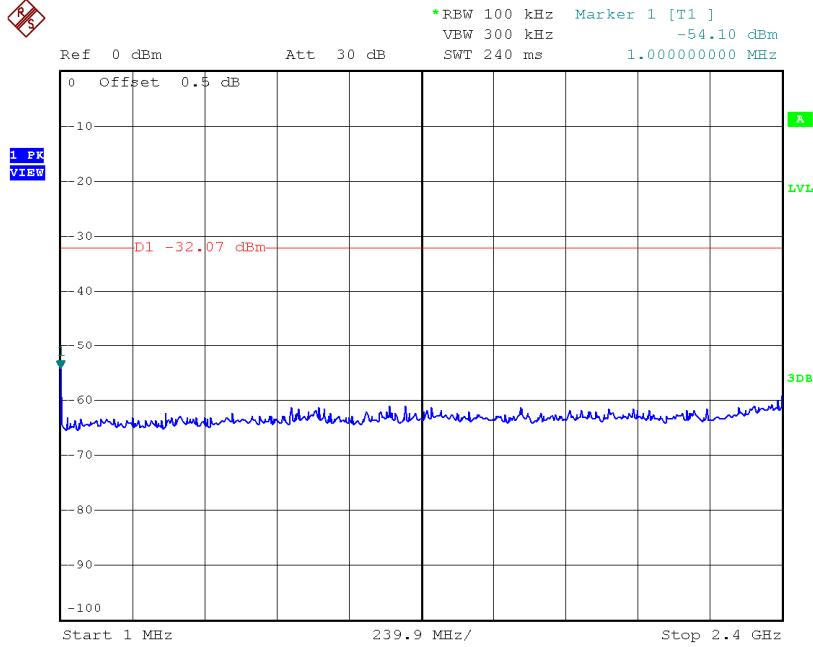

802.11b, Middle Channel, Plot B

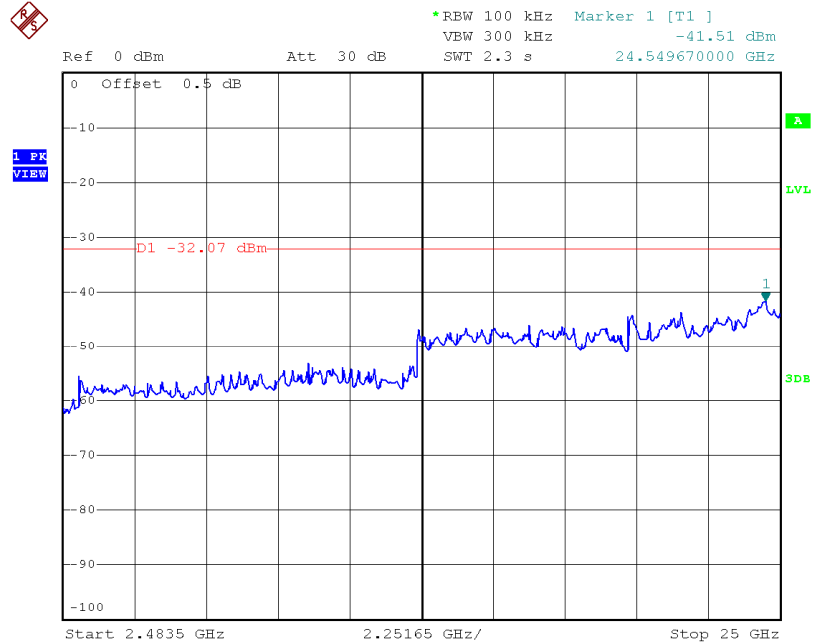

INTERTEK TESTING SERVICES

Plots of out of band conducted emissions

802.11b, Highest Channel, Plot A

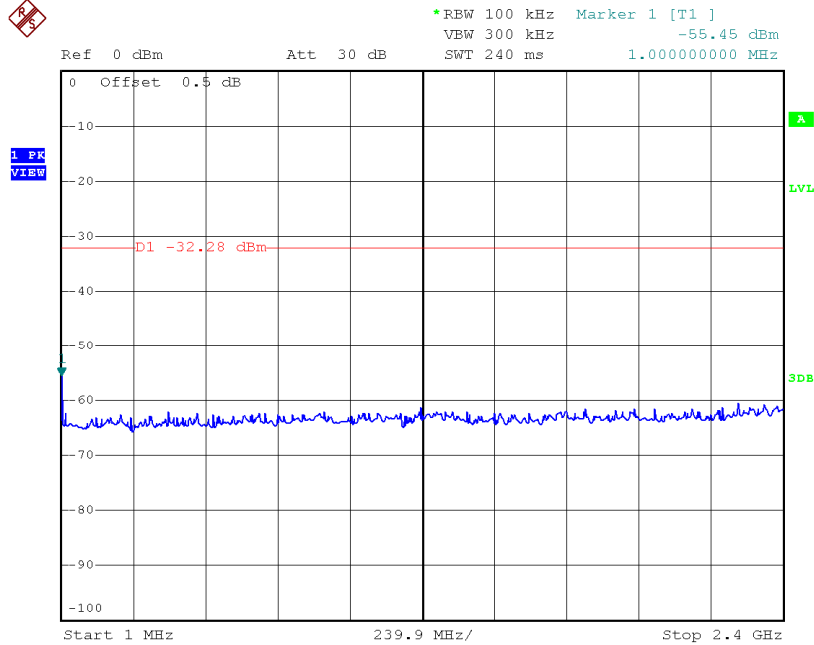

802.11b, Highest Channel, Plot B

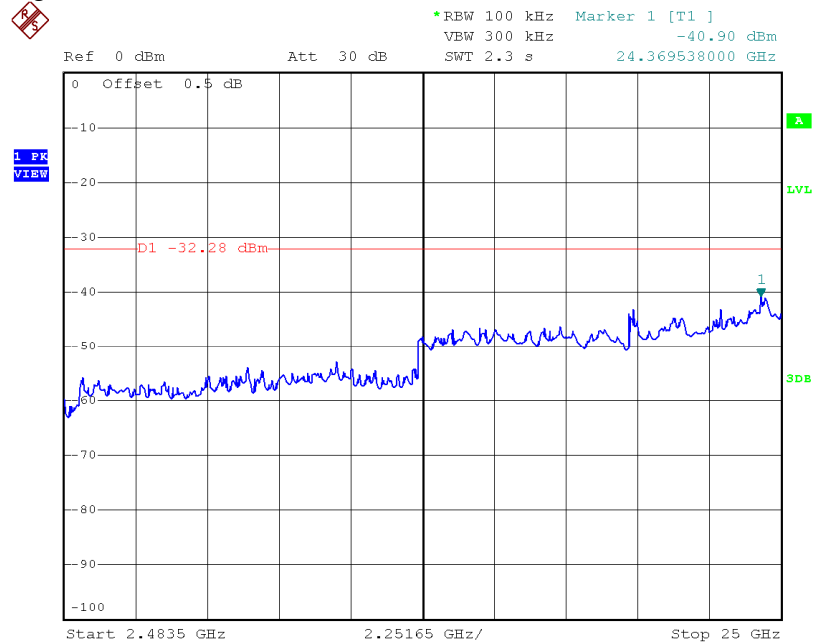

Plots of out of band conducted emissions

802.11g, Lowest Channel, Plot A

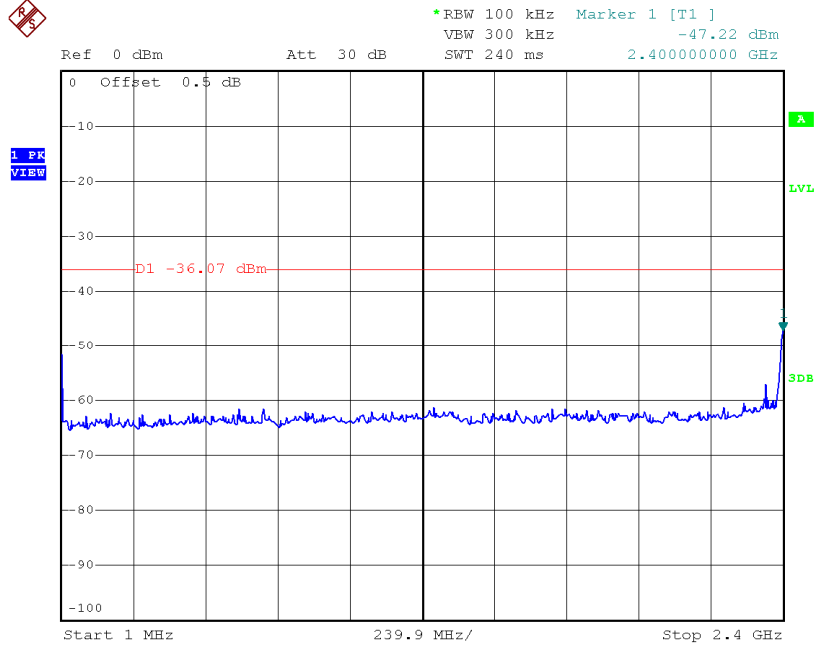

802.11g, Lowest Channel, Plot B

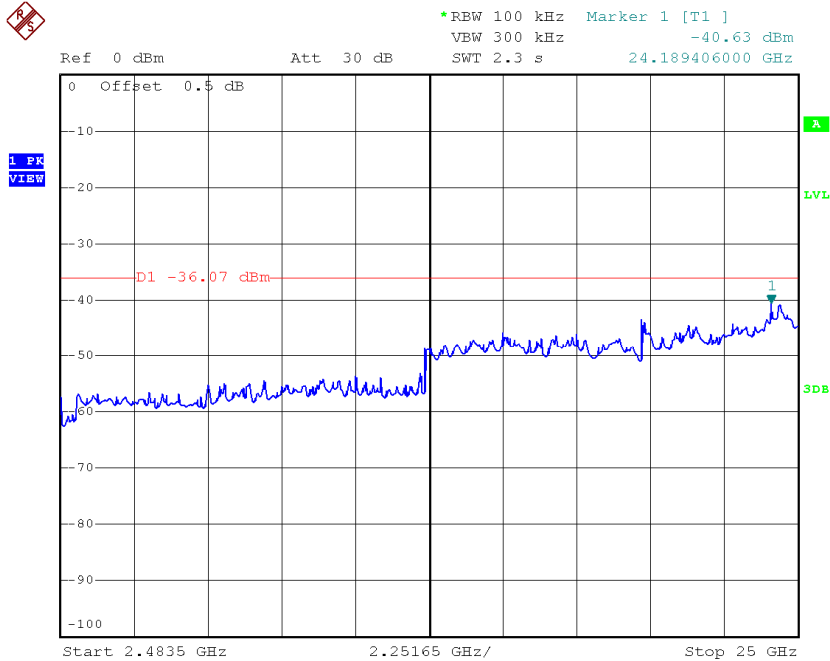

Plots of out of band conducted emissions

802.11g, Middle Channel, Plot A

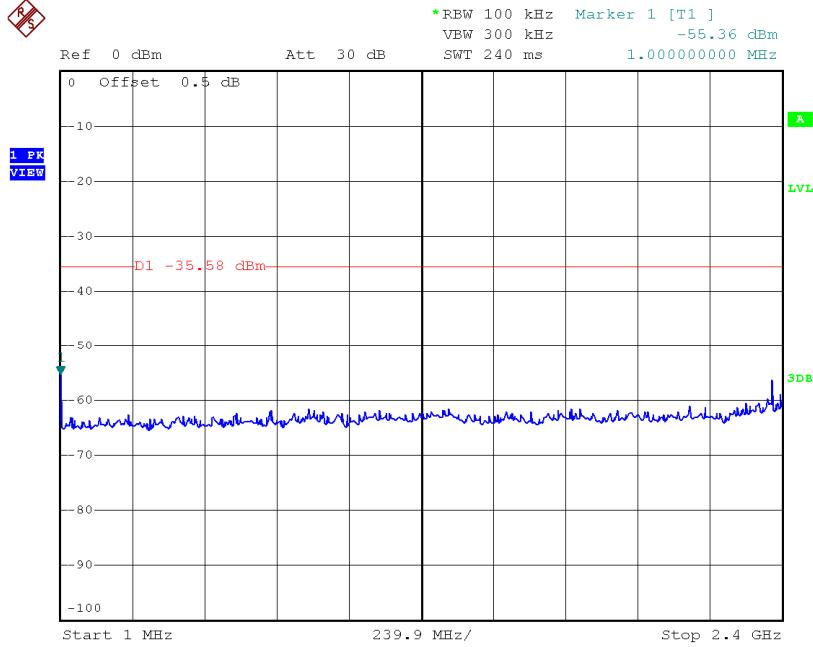

802.11g, Middle Channel, Plot B

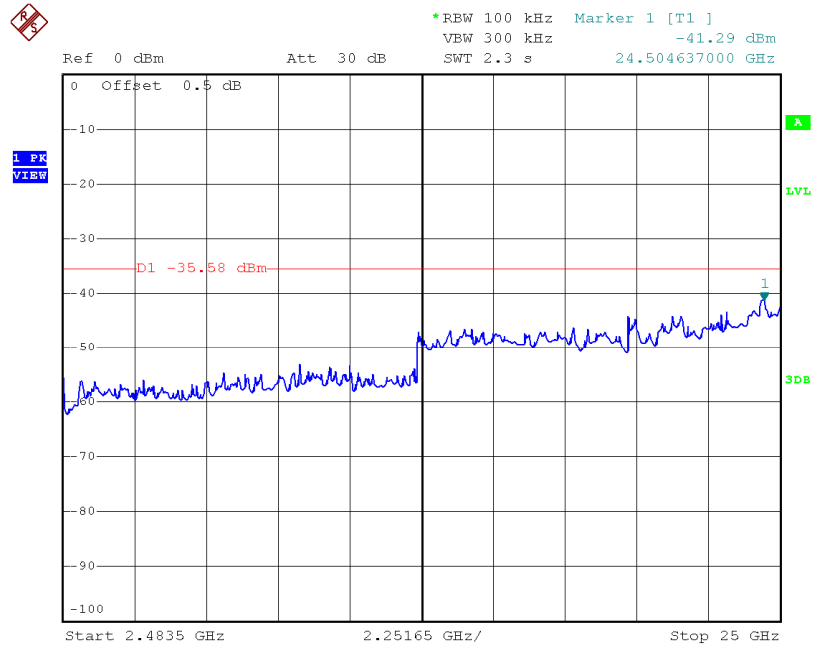

Plots of out of band conducted emissions

802.11g, Highest Channel, Plot A

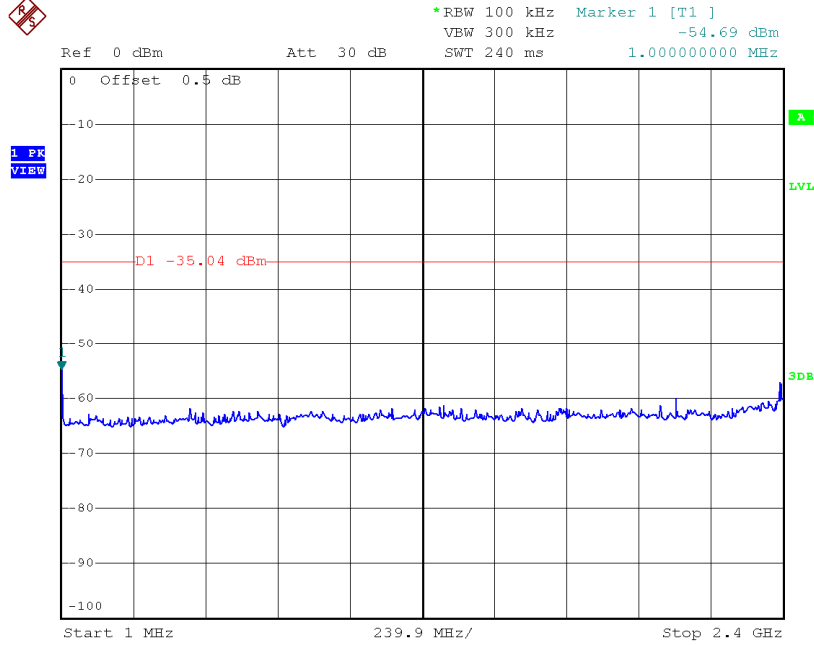

802.11g, Highest Channel, Plot B

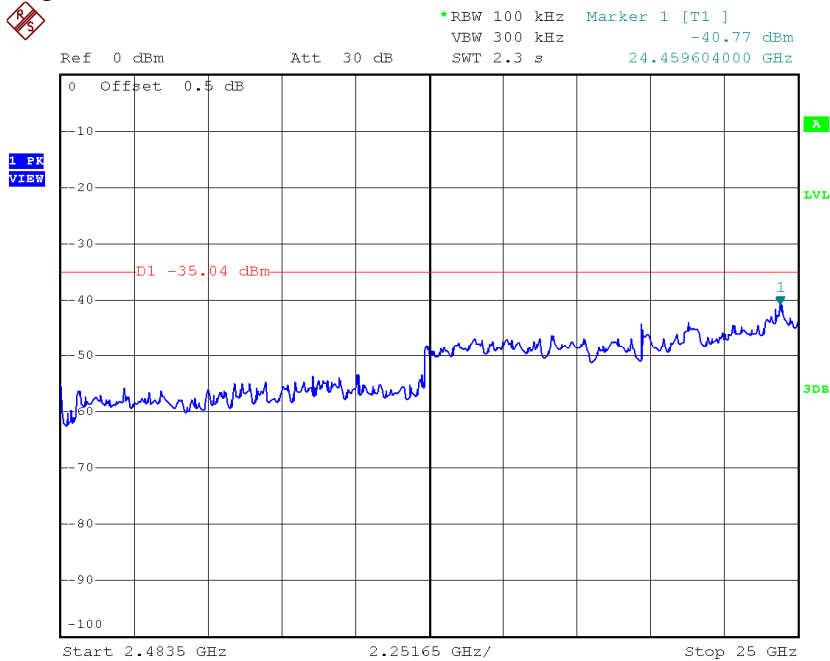

INTERTEK TESTING SERVICES

4.5 Field Strength Calculation

The field strength is calculated by adding the reading on the Spectrum Analyzer to the factors associated with preamplifiers (if any), antennas, cables, pulse desensitization and average factors (when specified limit is in average and measurements are made with peak detectors). A sample calculation is included below.

$$FS = RA + AF + CF - AG + PD + AV$$

Where

- FS = Field Strength in dB μ V/m
- RA = Receiver Amplitude (including preamplifier) in dB μ V
- CF = Cable Attenuation Factor in dB
- AF = Antenna Factor in dB
- AG = Amplifier Gain in dB
- PD = Pulse Desensitization in dB
- AV = Average Factor in -dB

In the radiated emission table which follows, the reading shown on the data table may reflect the preamplifier gain. An example of the calculations, where the reading does not reflect the preamplifier gain, follows:

$$FS = RA + AF + CF - AG + PD + AV$$

Example

Assume a receiver reading of 62.0 dB μ V is obtained. The antenna factor of 7.4 dB and cable factor of 1.6 dB is added. The amplifier gain of 29.0 dB is subtracted. The pulse desensitization factor of the spectrum analyzer is 0.0 dB, and the resultant average factor is -10.0 dB. The net field strength for comparison to the appropriate emission limit is 32.0 dB μ V/m. This value in dB μ V/m is converted to its corresponding level in μ V/m.

RA = 62.0 dB μ V
AF = 7.4 dB
CF = 1.6 dB
AG = 29.0 dB
PD = 0.0 dB
AV = -10 dB

$$FS = 62.0 + 7.4 + 1.6 - 29.0 + 0.0 + (-10.0) = 32.0 \text{ dB}\mu\text{V/m}$$

$$\text{Level in } \mu\text{V/m} = \text{Common Antilogarithm} [(32.0 \text{ dB}\mu\text{V/m})/20] = 39.8 \mu\text{V/m}$$

INTERTEK TESTING SERVICES

4.6 Transmitter Radiated Emissions in Restricted Bands and Spurious Emissions

Data is included of the worst case configuration (the configuration which resulted in the highest emission levels). A sample calculation, configuration photographs and data tables of the emissions are included.

The data on the following pages list the significant emission frequencies, the limit and the margin of compliance.

4.6.1 Radiated Emission Configuration Photograph

Worst Case Restricted Band Radiated Emission
at

375.077 MHz

The worst case radiated emission configuration photographs are saved with filename:
config photos.pdf

4.6.2 Radiated Emission Data

The data in tables 1-8 list the significant emission frequencies, the limit and the margin of compliance.

Judgement -

Passed by 1.0 dB margin

INTERTEK TESTING SERVICES

Mode: TX-Channel 01

Table 1
IEEE 802.11b (DSSS, 1 Mbps)

Radiated Emission Data

Polarization	Frequency (MHz)	Reading (dB μ V)	Pre-Amp Gain (dB)	Antenna Factor (dB)	Net at 3m - Peak (dB μ V/m)	Average Limit at 3m (dB μ V/m)	Margin (dB)
<i>H</i>	<i>2390.000</i>	<i>53.8</i>	<i>33</i>	<i>29.4</i>	<i>50.2</i>	<i>54.0</i>	<i>-3.8</i>
<i>H</i>	<i>4824.000</i>	<i>38.9</i>	<i>33</i>	<i>34.9</i>	<i>40.8</i>	<i>54.0</i>	<i>-13.2</i>
<i>V</i>	<i>12060.000</i>	<i>36.8</i>	<i>33</i>	<i>40.5</i>	<i>44.3</i>	<i>54.0</i>	<i>-9.7</i>
<i>H</i>	<i>14472.000</i>	<i>40.8</i>	<i>33</i>	<i>40.0</i>	<i>47.8</i>	<i>54.0</i>	<i>-6.2</i>

Polarization	Frequency (MHz)	Reading (dB μ V)	Pre-Amp Gain (dB)	Antenna Factor (dB)	Net at 3m - Peak (dB μ V/m)	Peak Limit at 3m (dB μ V/m)	Margin (dB)
<i>H</i>	<i>2390.000</i>	<i>64.3</i>	<i>33</i>	<i>29.4</i>	<i>60.7</i>	<i>74.0</i>	<i>-13.3</i>
<i>H</i>	<i>4824.000</i>	<i>48.8</i>	<i>33</i>	<i>34.9</i>	<i>50.7</i>	<i>74.0</i>	<i>-23.3</i>
<i>V</i>	<i>12060.000</i>	<i>42.8</i>	<i>33</i>	<i>40.5</i>	<i>50.3</i>	<i>74.0</i>	<i>-23.7</i>
<i>H</i>	<i>14472.000</i>	<i>46.6</i>	<i>33</i>	<i>40.0</i>	<i>53.6</i>	<i>74.0</i>	<i>-20.4</i>

- NOTES:
1. Peak detector is used for the emission measurement.
 2. Average detector is used for the average data of emission measurement
 3. All measurements were made at 3 meters. Radiated emissions not detected at the 3-meter distance were measured at 0.3-meter and an inverse proportional extrapolation was performed to compare the signal level to the 3-meter limit. No other radiated emissions than those reported were detected at a test distance of 0.3-meter.
 4. Negative value in the margin column shows emission below limit.
 5. Horn antenna is used for the emission over 1000MHz.
 6. Emission (the row indicated by ***bold italic***) within the restricted band meets the requirement of FCC Part 15 Section 15.205 / RSS-Gen Section 8.10.
 7. For the measurement of radiated emission, summation method was used which numerical integrating (in terms of linear power) over the transmitter occupied bandwidth.
 8. For the linear power measurement, data in 1MHz spacing was collected by spectrum analyzer with 1MHz resolution bandwidth.

INTERTEK TESTING SERVICES

Mode: TX-Channel 06

Table 2
IEEE 802.11b (DSSS, 1 Mbps)

Radiated Emission Data

Polarization	Frequency (MHz)	Reading (dBμV)	Pre-Amp Gain (dB)	Antenna Factor (dB)	Net at 3m - Peak (dBμV/m)	Average Limit at 3m (dBμV/m)	Margin (dB)
H	4874.000	38.2	33	34.9	40.1	54.0	-13.9
H	7311.000	36.7	33	37.9	41.6	54.0	-12.4
V	12185.000	37.2	33	40.5	44.7	54.0	-9.3

Polarization	Frequency (MHz)	Reading (dBμV)	Pre-Amp Gain (dB)	Antenna Factor (dB)	Net at 3m - Peak (dBμV/m)	Peak Limit at 3m (dBμV/m)	Margin (dB)
H	4874.000	48.5	33	34.9	50.4	74.0	-23.6
H	7311.000	42.6	33	37.9	47.5	74.0	-26.5
V	12185.000	43.0	33	40.5	50.5	74.0	-23.5

- NOTES:
1. Peak detector is used for the emission measurement.
 2. Average detector is used for the average data of emission measurement
 3. All measurements were made at 3 meters. Radiated emissions not detected at the 3-meter distance were measured at 0.3-meter and an inverse proportional extrapolation was performed to compare the signal level to the 3-meter limit. No other radiated emissions than those reported were detected at a test distance of 0.3-meter.
 4. Negative value in the margin column shows emission below limit.
 5. Horn antenna is used for the emission over 1000MHz.
 6. Emission (the row indicated by **bold italic**) within the restricted band meets the requirement of FCC Part 15 Section 15.205 / RSS-Gen Section 8.10.
 7. For the measurement of radiated emission, summation method was used which numerical integrating (in terms of linear power) over the transmitter occupied bandwidth.
 8. For the linear power measurement, data in 1MHz spacing was collected by spectrum analyzer with 1MHz resolution bandwidth.

INTERTEK TESTING SERVICES

Mode: TX-Channel 11

Table 3
IEEE 802.11b (DSSS, 1 Mbps)

Radiated Emission Data

Polarization	Frequency (MHz)	Reading (dB μ V)	Pre-Amp Gain (dB)	Antenna Factor (dB)	Net at 3m - Peak (dB μ V/m)	Average Limit at 3m (dB μ V/m)	Margin (dB)
<i>H</i>	<i>2483.500</i>	<i>53.0</i>	<i>33</i>	<i>29.4</i>	<i>49.4</i>	<i>54.0</i>	<i>-4.6</i>
<i>H</i>	<i>4924.000</i>	<i>38.5</i>	<i>33</i>	<i>34.9</i>	<i>40.4</i>	<i>54.0</i>	<i>-13.6</i>
<i>H</i>	<i>7386.000</i>	<i>36.8</i>	<i>33</i>	<i>37.9</i>	<i>41.7</i>	<i>54.0</i>	<i>-12.3</i>
<i>V</i>	<i>12310.000</i>	<i>36.9</i>	<i>33</i>	<i>40.5</i>	<i>44.4</i>	<i>54.0</i>	<i>-9.6</i>

Polarization	Frequency (MHz)	Reading (dB μ V)	Pre-Amp Gain (dB)	Antenna Factor (dB)	Net at 3m - Peak (dB μ V/m)	Peak Limit at 3m (dB μ V/m)	Margin (dB)
<i>H</i>	<i>2483.500</i>	<i>63.3</i>	<i>33</i>	<i>29.4</i>	<i>59.7</i>	<i>74.0</i>	<i>-14.3</i>
<i>H</i>	<i>4924.000</i>	<i>48.3</i>	<i>33</i>	<i>34.9</i>	<i>50.2</i>	<i>74.0</i>	<i>-23.8</i>
<i>H</i>	<i>7386.000</i>	<i>42.8</i>	<i>33</i>	<i>37.9</i>	<i>47.7</i>	<i>74.0</i>	<i>-26.3</i>
<i>V</i>	<i>12310.000</i>	<i>43.3</i>	<i>33</i>	<i>40.5</i>	<i>50.8</i>	<i>74.0</i>	<i>-23.2</i>

- NOTES:
1. Peak detector is used for the emission measurement.
 2. Average detector is used for the average data of emission measurement
 3. All measurements were made at 3 meters. Radiated emissions not detected at the 3-meter distance were measured at 0.3-meter and an inverse proportional extrapolation was performed to compare the signal level to the 3-meter limit. No other radiated emissions than those reported were detected at a test distance of 0.3-meter.
 4. Negative value in the margin column shows emission below limit.
 5. Horn antenna is used for the emission over 1000MHz.
 6. Emission (the row indicated by ***bold italic***) within the restricted band meets the requirement of FCC Part 15 Section 15.205 / RSS-Gen Section 8.10.
 7. For the measurement of radiated emission, summation method was used which numerical integrating (in terms of linear power) over the transmitter occupied bandwidth.
 8. For the linear power measurement, data in 1MHz spacing was collected by spectrum analyzer with 1MHz resolution bandwidth.

INTERTEK TESTING SERVICES

Mode: TX-Channel 01

Table 4
IEEE 802.11g (OFDM, 6 Mbps)

Radiated Emission Data

Polarization	Frequency (MHz)	Reading (dB μ V)	Pre-Amp Gain (dB)	Antenna Factor (dB)	Net at 3m - Peak (dB μ V/m)	Average Limit at 3m (dB μ V/m)	Margin (dB)
<i>H</i>	<i>4824.000</i>	<i>37.2</i>	<i>33</i>	<i>34.9</i>	<i>39.1</i>	<i>54.0</i>	<i>-14.9</i>
<i>V</i>	<i>12060.000</i>	<i>37.4</i>	<i>33</i>	<i>40.5</i>	<i>44.9</i>	<i>54.0</i>	<i>-9.1</i>
<i>H</i>	<i>14472.000</i>	<i>40.3</i>	<i>33</i>	<i>40.0</i>	<i>47.3</i>	<i>54.0</i>	<i>-6.7</i>
<i>H</i>	<i>2390.000</i>	<i>55.3</i>	<i>33</i>	<i>29.4</i>	<i>51.7</i>	<i>54.0</i>	<i>-2.3</i>

Polarization	Frequency (MHz)	Reading (dB μ V)	Pre-Amp Gain (dB)	Antenna Factor (dB)	Net at 3m - Peak (dB μ V/m)	Peak Limit at 3m (dB μ V/m)	Margin (dB)
<i>H</i>	<i>2390.000</i>	<i>63.2</i>	<i>33</i>	<i>29.4</i>	<i>59.6</i>	<i>74.0</i>	<i>-14.4</i>
<i>H</i>	<i>4824.000</i>	<i>44.3</i>	<i>33</i>	<i>34.9</i>	<i>46.2</i>	<i>74.0</i>	<i>-27.8</i>
<i>V</i>	<i>12060.000</i>	<i>43.1</i>	<i>33</i>	<i>40.5</i>	<i>50.6</i>	<i>74.0</i>	<i>-23.4</i>
<i>H</i>	<i>14472.000</i>	<i>45.8</i>	<i>33</i>	<i>40.0</i>	<i>52.8</i>	<i>74.0</i>	<i>-21.2</i>

- NOTES:
1. Peak detector is used for the emission measurement.
 2. Average detector is used for the average data of emission measurement
 3. All measurements were made at 3 meters. Radiated emissions not detected at the 3-meter distance were measured at 0.3-meter and an inverse proportional extrapolation was performed to compare the signal level to the 3-meter limit. No other radiated emissions than those reported were detected at a test distance of 0.3-meter.
 4. Negative value in the margin column shows emission below limit.
 5. Horn antenna is used for the emission over 1000MHz.
 6. Emission (the row indicated by ***bold italic***) within the restricted band meets the requirement of FCC Part 15 Section 15.205 / RSS-Gen Section 8.10.
 7. For the measurement of radiated emission, summation method was used which numerical integrating (in terms of linear power) over the transmitter occupied bandwidth.
 8. For the linear power measurement, data in 1MHz spacing was collected by spectrum analyzer with 1MHz resolution bandwidth.

INTERTEK TESTING SERVICES

Mode: TX-Channel 06

Table 5
IEEE 802.11g (OFDM, 6 Mbps)

Radiated Emission Data

Polarization	Frequency (MHz)	Reading (dBμV)	Pre-Amp Gain (dB)	Antenna Factor (dB)	Net at 3m - Peak (dBμV/m)	Average Limit at 3m (dBμV/m)	Margin (dB)
<i>H</i>	<i>4874.000</i>	<i>37.5</i>	<i>33</i>	<i>34.9</i>	<i>39.4</i>	<i>54.0</i>	<i>-14.6</i>
<i>V</i>	<i>7311.000</i>	<i>35.3</i>	<i>33</i>	<i>37.9</i>	<i>40.2</i>	<i>54.0</i>	<i>-13.8</i>
<i>V</i>	<i>12185.000</i>	<i>37.0</i>	<i>33</i>	<i>40.5</i>	<i>44.5</i>	<i>54.0</i>	<i>-9.5</i>

Polarization	Frequency (MHz)	Reading (dBμV)	Pre-Amp Gain (dB)	Antenna Factor (dB)	Net at 3m - Peak (dBμV/m)	Peak Limit at 3m (dBμV/m)	Margin (dB)
<i>H</i>	<i>4874.000</i>	<i>44.3</i>	<i>33</i>	<i>34.9</i>	<i>46.2</i>	<i>74.0</i>	<i>-27.8</i>
<i>V</i>	<i>7311.000</i>	<i>41.6</i>	<i>33</i>	<i>37.9</i>	<i>46.5</i>	<i>74.0</i>	<i>-27.5</i>
<i>V</i>	<i>12185.000</i>	<i>43.0</i>	<i>33</i>	<i>40.5</i>	<i>50.5</i>	<i>74.0</i>	<i>-23.5</i>

- NOTES:
1. Peak detector is used for the emission measurement.
 2. Average detector is used for the average data of emission measurement
 3. All measurements were made at 3 meters. Radiated emissions not detected at the 3-meter distance were measured at 0.3-meter and an inverse proportional extrapolation was performed to compare the signal level to the 3-meter limit. No other radiated emissions than those reported were detected at a test distance of 0.3-meter.
 4. Negative value in the margin column shows emission below limit.
 5. Horn antenna is used for the emission over 1000MHz.
 6. Emission (the row indicated by ***bold italic***) within the restricted band meets the requirement of FCC Part 15 Section 15.205 / RSS-Gen Section 8.10.
 7. For the measurement of radiated emission, summation method was used which numerical integrating (in terms of linear power) over the transmitter occupied bandwidth.
 8. For the linear power measurement, data in 1MHz spacing was collected by spectrum analyzer with 1MHz resolution bandwidth.

INTERTEK TESTING SERVICES

Mode: TX-Channel 11

Table 6
IEEE 802.11g (OFDM, 6 Mbps)

Radiated Emission Data

Polarization	Frequency (MHz)	Reading (dBμV)	Pre-Amp Gain (dB)	Antenna Factor (dB)	Net at 3m - Peak (dBμV/m)	Average Limit at 3m (dBμV/m)	Margin (dB)
H	2483.500	54.6	33	29.4	51.0	54.0	-3.0
H	4924.000	37.2	33	34.9	39.1	54.0	-14.9
V	7386.000	35.9	33	37.9	40.8	54.0	-13.2
V	12310.000	36.8	33	40.5	44.3	54.0	-9.7

Polarization	Frequency (MHz)	Reading (dBμV)	Pre-Amp Gain (dB)	Antenna Factor (dB)	Net at 3m - Peak (dBμV/m)	Peak Limit at 3m (dBμV/m)	Margin (dB)
H	2483.500	64.8	33	29.4	61.2	74.0	-12.8
H	4924.000	44.3	33	34.9	46.2	74.0	-27.8
V	7386.000	41.4	33	37.9	46.3	74.0	-27.7
V	12310.000	43.2	33	40.5	50.7	74.0	-23.3

- NOTES:
1. Peak detector is used for the emission measurement.
 2. Average detector is used for the average data of emission measurement
 3. All measurements were made at 3 meters. Radiated emissions not detected at the 3-meter distance were measured at 0.3-meter and an inverse proportional extrapolation was performed to compare the signal level to the 3-meter limit. No other radiated emissions than those reported were detected at a test distance of 0.3-meter.
 4. Negative value in the margin column shows emission below limit.
 5. Horn antenna is used for the emission over 1000MHz.
 6. Emission (the row indicated by **bold italic**) within the restricted band meets the requirement of FCC Part 15 Section 15.205 / RSS-Gen Section 8.10.
 7. For the measurement of radiated emission, summation method was used which numerical integrating (in terms of linear power) over the transmitter occupied bandwidth.
 8. For the linear power measurement, data in 1MHz spacing was collected by spectrum analyzer with 1MHz resolution bandwidth.

INTERTEK TESTING SERVICES

Mode: Tx Other

Table 7

Radiated Emission Data

Polarization	Frequency (MHz)	Reading (dBμV)	Pre-amp (dB)	Antenna Factor (dB)	Net at 3m (dBμV/m)	Limit at 3m (dBμV/m)	Margin (dB)
H	108.933	33.1	16	14.0	31.1	43.5	-12.4
H	128.697	36.7	16	14.0	34.7	43.5	-8.8
H	171.498	33.7	16	18.0	35.7	43.5	-7.8
V	206.297	34.6	16	17.0	35.6	43.5	-7.9
H	224.970	34.0	16	18.0	36.0	46.0	-10.0
H	249.947	32.0	16	20.0	36.0	46.0	-10.0
H	300.023	34.8	16	22.0	40.8	46.0	-5.2
H	375.077	37.0	16	24.0	45.0	46.0	-1.0
H	390.597	29.3	16	25.0	38.3	46.0	-7.7
H	395.205	32.1	16	25.0	41.1	46.0	-4.9
V	399.691	33.6	16	25.0	42.6	46.0	-3.4
H	404.541	32.2	16	24.0	40.2	46.0	-5.8
V	450.010	32.4	16	26.0	42.4	46.0	-3.6
V	525.063	31.3	16	27.0	42.3	46.0	-3.7
V	720.033	24.7	16	30.0	38.7	46.0	-7.3
H	750.103	23.4	16	30.0	37.4	46.0	-8.6
V	960.108	19.4	16	33.0	36.4	54.0	-17.6

- NOTES:
1. Peak detector is used for the emission measurement.
 2. All measurements were made at 3 meters. Radiated emissions not detected at the 3-meter distance were measured at 0.3-meter and an inverse proportional extrapolation was performed to compare the signal level to the 3-meter limit. No other radiated emissions than those reported were detected at a test distance of 0.3-meter.
 3. Negative value in the margin column shows emission below limit.
 4. Emission (the row indicated by **bold italic**) within the restricted band meets the requirement of FCC Part 15 Section 15.205 / RSS-Gen Section 8.10.

INTERTEK TESTING SERVICES

Mode: Speakerphone Online with WiFi On

Table 8

Radiated Emission Data

Polarization	Frequency (MHz)	Reading (dB μ V)	Pre-amp (dB)	Antenna Factor (dB)	Net at 3m (dB μ V/m)	Limit at 3m (dB μ V/m)	Margin (dB)
V	46.978	30.6	16	11.0	25.6	40.0	-14.4
V	78.503	38.2	16	6.0	28.2	40.0	-11.8
V	150.409	39.6	16	14.0	37.6	43.5	-5.9
H	224.972	36.5	16	18.0	38.5	46.0	-7.5
H	299.906	37.0	16	22.0	43.0	46.0	-3.0
H	374.950	35.6	16	24.0	43.6	46.0	-2.4
H	400.541	34.9	16	24.0	42.9	46.0	-3.1
V	450.012	31.3	16	26.0	41.3	46.0	-4.7
H	524.982	29.5	16	27.0	40.5	46.0	-5.5
V	750.104	26.2	16	30.0	40.2	46.0	-5.8

- NOTES:
1. Peak detector is used for the emission measurement.
 2. All measurements were made at 3 meters. Radiated emissions not detected at the 3-meter distance were measured at 0.3-meter and an inverse proportional extrapolation was performed to compare the signal level to the 3-meter limit. No other radiated emissions than those reported were detected at a test distance of 0.3-meter.
 3. Negative value in the margin column shows emission below limit.
 4. Emission (the row indicated by **bold italic**) within the restricted band meets the requirement of FCC Part 15 Section 15.205 / RSS-Gen Section 8.10.

INTERTEK TESTING SERVICES

4.6.3 Radiated Emission Test Setup

The figure below shows the test setup, which is utilized to make these measurements.

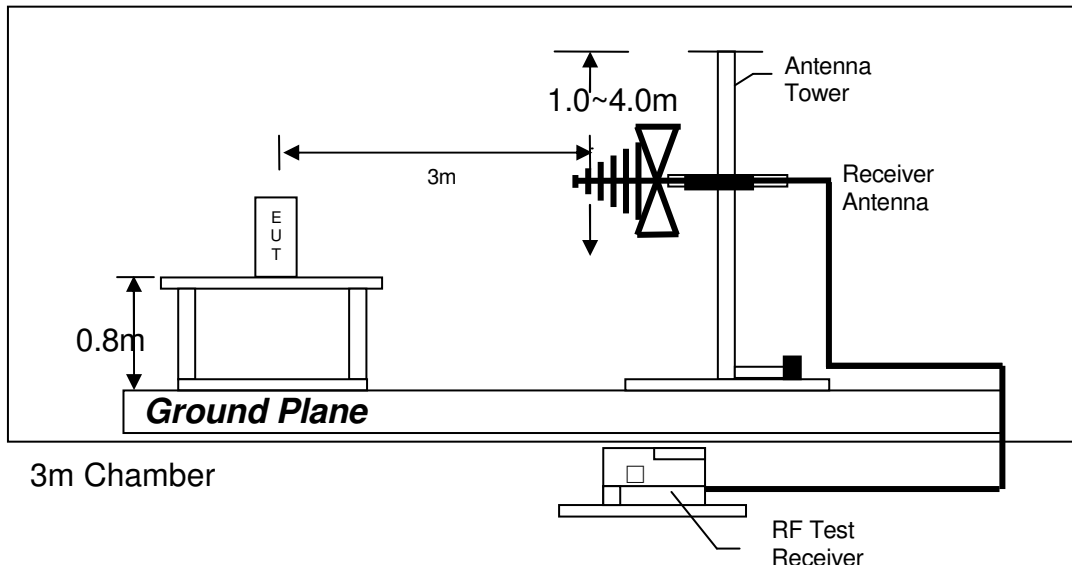

Test setup of radiated emissions up to 1GHz

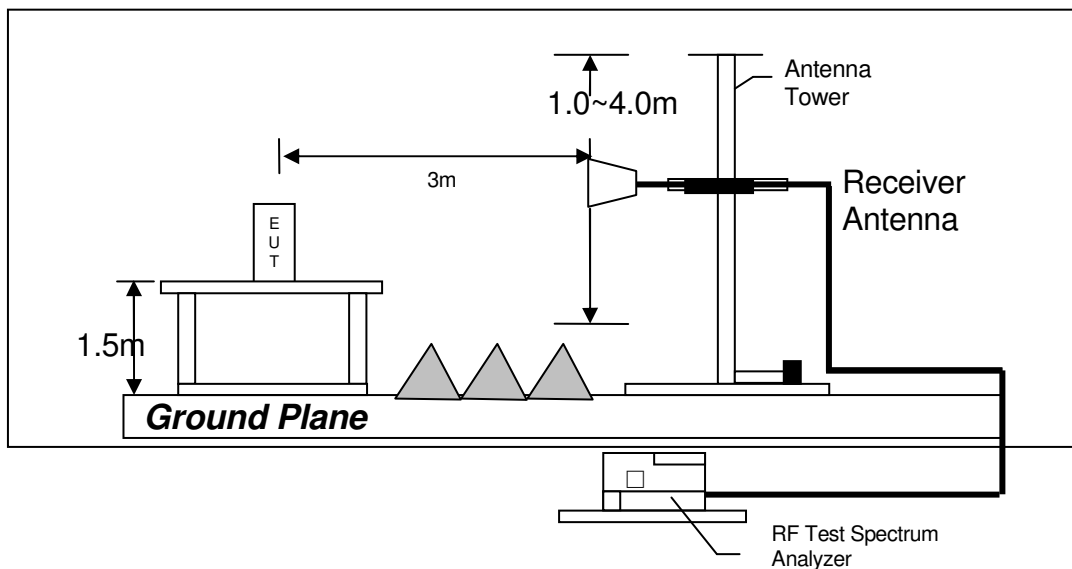

Test setup of radiated emissions above 1GHz

INTERTEK TESTING SERVICES

4.6.4 Transmitter Duty Cycle Calculation

Not applicable – No average factor is required.

INTERTEK TESTING SERVICES

4.7 AC Power Line Conducted Emission

- Not applicable – EUT is only powered by battery for operation.
- EUT connects to AC power line. Emission Data is listed in following pages.

- Base Unit connects to AC power line and has transmission. Handset connects to AC power line but has no transmission. Emission Data of Base Unit is listed in following pages.

4.7.1 AC Power Line Conducted Emission Configuration Photograph

Worst Case Line-Conducted Configuration
at
267 kHz

The worst case line conducted configuration photographs are attached in the Appendix and saved with filename: config photos.pdf

4.7.2 AC Power Line Conducted Emission Data

The plot(s) and data in the following pages list the significant emission frequencies, the limit and the margin of compliance.

Passed by 6.43 dB margin compare with CISPR Average limit

INTERTEK TESTING SERVICES

Worst Case: Speakerphone online with WiFi On



RBW 9 kHz
MT 1 s

Att 10 dB AUTO PREAMP OFF

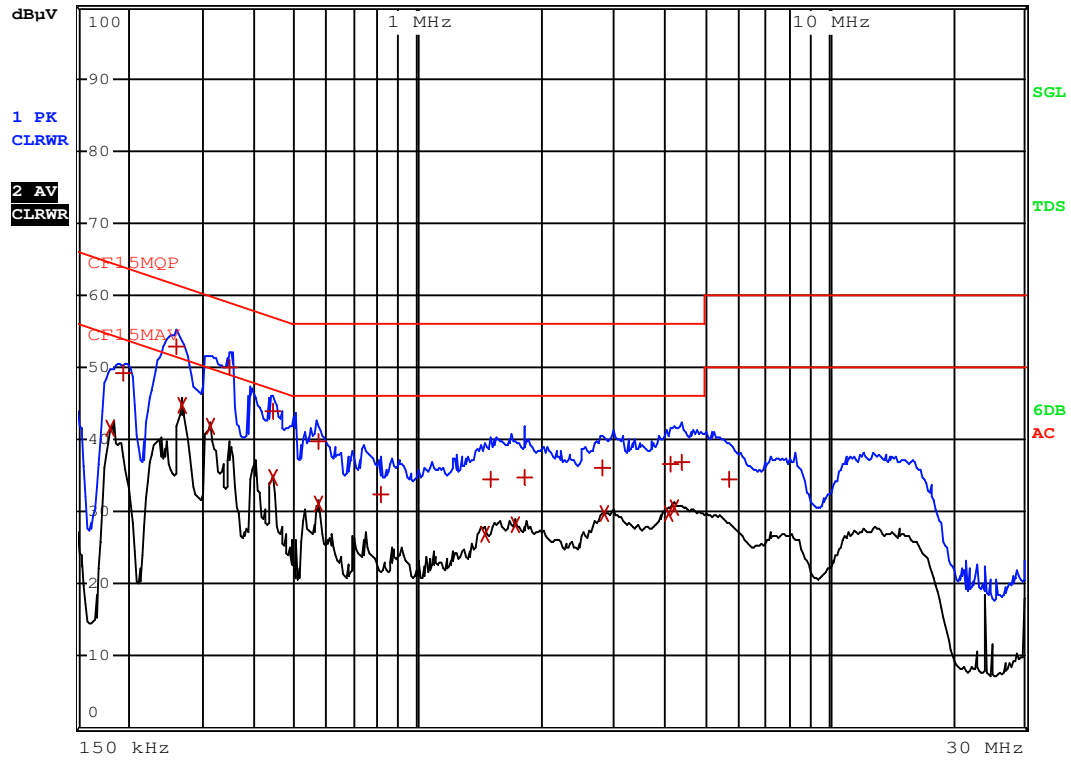

INTERTEK TESTING SERVICES

Worst Case: Speakerphone online with WiFi On

EDIT PEAK LIST (Final Measurement Results)				
Trace1:	CF15MQP			
Trace2:	CF15MAV			
Trace3:	---			
TRACE	FREQUENCY	LEVEL dB μ V		DELTA LIMIT dB
2 CISPR Average	181.5 kHz	41.69	N	-12.72
1 Quasi Peak	195 kHz	49.22	N	-14.59
1 Quasi Peak	258 kHz	52.81	L1	-8.67
2 CISPR Average	267 kHz	44.77	L1	-6.43
2 CISPR Average	312 kHz	41.80	N	-8.10
1 Quasi Peak	352.5 kHz	49.89	L1	-9.01
1 Quasi Peak	442.5 kHz	43.90	L1	-13.11
2 CISPR Average	442.5 kHz	34.76	N	-12.24
1 Quasi Peak	573 kHz	39.69	L1	-16.30
2 CISPR Average	573 kHz	31.01	N	-14.98
1 Quasi Peak	811.5 kHz	32.38	L1	-23.61
2 CISPR Average	1.4595 MHz	27.00	L1	-18.99
1 Quasi Peak	1.5 MHz	34.63	N	-21.36
2 CISPR Average	1.725 MHz	28.13	L1	-17.87
1 Quasi Peak	1.8285 MHz	34.79	N	-21.20
1 Quasi Peak	2.832 MHz	36.10	L1	-19.89
2 CISPR Average	2.85 MHz	29.82	N	-16.17
2 CISPR Average	4.0695 MHz	29.78	N	-16.21
1 Quasi Peak	4.11 MHz	36.68	L1	-19.31
2 CISPR Average	4.236 MHz	30.57	N	-15.42

INTERTEK TESTING SERVICES

Worst Case: Speakerphone online with WiFi On

EDIT PEAK LIST (Final Measurement Results)				
TRACE		FREQUENCY	LEVEL dB μ V	DELTA LIMIT dB
Trace1:	CF15MQP			
Trace2:	CF15MAV			
Trace3:	---			
1	Quasi Peak	4.38 MHz	36.82 N	-19.17
1	Quasi Peak	5.7525 MHz	34.44 L1	-25.55

INTERTEK TESTING SERVICES

4.7.3 Conducted Emission Test Setup

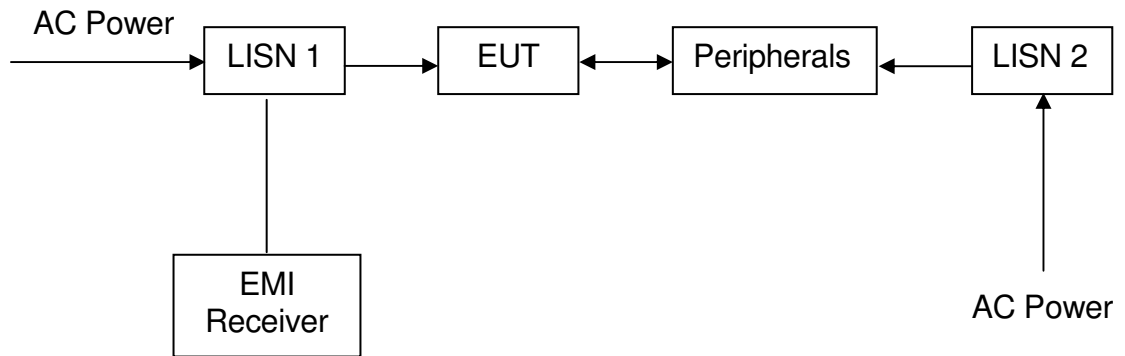

INTERTEK TESTING SERVICES

**EXHIBIT 5
EQUIPMENT LIST**

INTERTEK TESTING SERVICES

5.0 Equipment List

1) Radiated Emissions Test

Equipment	EMI Test Receiver	Spectrum Analyzer
Registration No.	EW-3095	EW-2466
Manufacturer	R&S	R&S
Model No.	ESCI	FSP30
Calibration Date	Oct. 25, 2016	Oct. 03, 2016
Calibration Due Date	Oct. 25, 2017	Aug. 20, 2017

Equipment	Biconical Antenna	Log Periodic Antenna	Double Ridged Guide Antenna
Registration No.	EW-0571	EW-0447	EW-1133
Manufacturer	EMCO	EMCO	EMCO
Model No.	3104C	3146	3115
Calibration Date	May. 18, 2016	May. 18, 2016	Nov. 05, 2015
Calibration Due Date	Nov. 18, 2017	Nov. 18, 2017	May 05, 2017

Equipment	Broad-Band Horn Antenna with frequency range 14G - 40GHz	Telephone Line Simulator
Registration No.	EW-1679	EW-3007
Manufacturer	SCHWARZBECK	TELTONE
Model No.	BBHA9170	TLS-5D-01
Calibration Date	June. 28, 2016	Feb. 22, 2016
Calibration Due Date	June. 28, 2017	Feb. 26, 2017

2) Conducted Emissions Test

Equipment	EMI Test Receiver	LISN	Telephone Line Simulator
Registration No.	EW-2500	EW-2501	EW-3007
Manufacturer	R&S	R&S	TELTONE
Model No.	ESCI	ENV-216	TLS-5D-01
Calibration Date	Jan. 28, 2016	Jan. 28, 2016	Feb. 22, 2016
Calibration Due Date	Jan. 28, 2017	Jan. 28, 2017	Feb. 26, 2017

3) Conductive Measurement Test

Equipment	Spectrum Analyzer
Registration No.	EW-2466
Manufacturer	R&S
Model No.	FSP30
Calibration Date	Oct. 03, 2016
Calibration Due Date	Aug. 20, 2017

END OF TEST REPORT