



EXHIBIT 2A

Test Report Provided by Nortel Networks

Applicant: Nortel Networks

**For Original Equipment
Certification on:**

AB6NT800MFRM2-CG



Test Report for FCC Equipment Authorization

FCC ID AB6NT800MFRM2-CG

Document: TR_AB6NT800MFRM2_Carrier 8-9
Stream: 00
Issue: 1.0
Document Status: Approved
Issue Date: Feb 6, 2004
Security Status: Nortel Networks Confidential
Author: Lorne Thompson

© 2004 Nortel Networks Limited

Disclaimer

The master of this document is stored on an electronic database and "write protected". The protection can be altered by authorized persons only. Viewing of the master document electronically ensures access to the current issue. Any hardcopies must be regarded as uncontrolled copies.

Security Warning

The information disclosed herein is proprietary to Nortel Networks and not to be used by or disclosed by unauthorized persons without the written consent of Nortel Networks. The recipient of this document shall respect the security status of the information.

PAGE INTENTIONALLY LEFT BLANK

Table of Contents

Publication History	9
List of Consultants	9
Decision Maker	9
Decision Ratifier	9
Revision History	10
Acronyms and Abbreviations	11
1 Introduction.....	13
1.1 Required Tests	13
2 Engineering Declaration.....	14
3 Equipment Authorization Application Requirements	15
3.1 Standard Test Conditions and Test Equipment.....	15
3.2 EUT Identification List.....	15
3.3 Test Equipment List.....	16
4 Transmitter Tests.....	17
4.1 RF Power Output	17
4.1.1 RF Power Output Requirements	17
4.1.1 FCC Part 2.1046 Measurements required: RF power output.....	17
4.1.2 Test Method	17
4.1.3 Test Setup	17
4.1.4 DOM	17
4.1.5 Noise Floor	18
4.1.6 RF Output Power Test Results.....	19
4.2 Certification Requirements	21
4.2.1 Application for certification.....	21
4.2.1 FCC Part 2.1033 Application for certification.....	21
4.2.2 Test Method	21
4.2.3 Test Setup	21
4.2.4 Test Results.....	21
4.3 Occupied Bandwidth.....	22
4.3.1 Occupied Bandwidth Requirements	22
4.3.1 FCC Part 2.1049	22
4.3.2 Test Method	22
4.3.3 Test Setup	22
4.3.4 Test Result	23
4.4 Spurious Emissions at Antenna Terminals	26
4.4.1 Spurious Emissions Requirements.....	26
4.4.1 FCC Part 2.1051	26
4.4.1 FCC Part 2.1057 - Frequency Spectrum to be investigated.....	26
4.4.1 FCC Part 22.917 Limit.....	26
4.4.2 Test Method	27
4.4.2.1 Adjacent 1MHz to indicated cellular band (Upper and Lower)	27

4.4.2.2 All other Spurious Emissions up to 10 GHz.....	28
4.4.3 Test Requirements	28
4.4.4 Test Setup	29
4.4.5 Test Results IS95	30
4.4.6 Test Results IS856	37
4.5 Transmitter Tests (CDMA Mode)	40
4.5 Unwanted Emissions.....	40
4.5 IC RSS-129	40
4.5.1 Test Method	40
4.5.1.1 Adjacent 1MHz to indicated cellular band (Upper and Lower)	41
4.5.2 Test Setup	42
4.5.3 Test Results.....	43
4.6 Frequency Stability	48
4.6.1 Frequency Stability Requirements.....	48
4.6.1 FCC Part 2.1055	48
4.6.2 Test Procedure	49
4.6.3 Frequency Results.....	49
References.....	53

List of Figures

Figure 1 : Test Setup for RF Power Output Measurement	18
Figure 2 : Test Setup for Occupied Bandwidth Measurement.....	23
Figure 3 : Test Setup for Spurious Emissions Measurement.....	29
Figure 4 : Test Setup for Spurious Emissions Measurement.....	42
Figure 5 : Test configuration for Frequency Stability	49

List of Tables

Table 1 : Required Tests	13
Table 2 : EUT Identification List.....	15
Table 3 : Test Equipment List.....	16
Table 6 : RF Output Power 800 MHz MFRM2 2-Carrier IS95.....	19
Table 5 : RF Output Power 800 MHz MFRM2 1-Carrier IS95.....	19
Table 7 : RF Output Power of 800 MHz MFRM2 3-Carrier IS95	19
Table 8 : RF Output Power 800 MHz MFRM2 1-Carrier IS856.....	20
Table 9 : RF Output Power of 800 MHz MFRM2 3-Carrier IS856	20
Table 11 : Average Current Values @ Pout = 48.45 dBm	21
Table 12 : Measured Occupied Bandwidth 800 MHz MFRM2 1-Carrier IS95	23
Table 13 : Measured Occupied Bandwidth800 MHz MFRM2 2-Carrier IS95	24
Table 14 : Measured Occupied Bandwidth of 800 MHz MFRM2 3-Carrier IS95.....	24
Table 15 : Measured Occupied Bandwidth 800 MHz MFRM2 1-Carrier IS856 16-QAM.....	24
Table 16 : Measured Occupied Bandwidth 800 MHz MFRM2 3-Carrier IS856 16-QAM.....	24
Table 19 : All other Emission Spectrum Analyze Settings	28
Table 21 : Spurious Emissions at the 800 MHz MFRM2 Ant. Port one Carrier band A and A'' IS95.....	30
Table 22 : Spurious Emissions at the 800 MHz MFRM2 Ant. Port two Carrier band A and A'' IS95.....	31
Table 23 : Spurious Emissions at the 800 MHz MFRM2 Ant. Port Three Carrier band A and A'' IS-95.....	32
Table 24 : Spurious Emissions at the 800 MHz MFRM2 Ant. Port One Carrier band B IS-95...33	
Table 25 : Spurious Emissions at the 800 MHz MFRM2 Ant. Port Three Carrier band B IS-95 34	
Table 26 : Spurious Emissions at the 800 MHz MFRM2 Ant. Port One Carrier band A' IS-95 .35	
Table 27 : Spurious Emissions at the 800 MHz MFRM2 Ant. Port One Carrier band B' IS95..36	
Table 28 : Spurious Emissions at the 800 MHz MFRM2 Ant. Port One Carrier Band A and A'' IS856.....	37
Table 32 : Industry Canada Suppression inside cellular band 800 MHz MFRM2 Antenna Port IS95, 1 Carrier band A''	43
Table 33 : Industry Canada Suppression inside cellular band 800 MHz MFRM2 Antenna Port IS95, 3 Carrier band A'' and A.....	44
Table 34 : Industry Canada Suppression inside cellular band 800 MHz MFRM2 Antenna Port	

IS856, 1 Carrier band A'45

Table 35 : Industry Canada Suppression inside cellular band 800 MHz MFRM2 Antenna Port
IS95, 1 Carrier band B'46

Table 36 : Industry Canada Suppression inside cellular band 800 MHz MFRM2 Antenna Port
Combination IS856(1015,33) and IS95 (74) 3 Carrier band A and A''47

Table 37 : Test results for Frequency Stability versus Power supply Voltage49

Table 38 : Test results for Frequency Stability versus Temperature at -48V operation50

Table 39 : Test results for Frequency Stability versus Temperature at 24V operation51

Publication History

The latest controlled release of this document is located in Livelink at the following location:

[http://livelink-ott.ca.nortel.com/livelink/livelink.exe/8261176/
FCC_part_22_8th_and_9th_Carrier_Test_Report.pdf?func=doc.Fetch&nodeid=8261176](http://livelink-ott.ca.nortel.com/livelink/livelink.exe/8261176/FCC_part_22_8th_and_9th_Carrier_Test_Report.pdf?func=doc.Fetch&nodeid=8261176)

All other soft and hard copies are uncontrolled. It is the responsibility of the reader to ensure that the latest release of this document is being used.

List of Consultants

The following people have reviewed this document prior to its release and have recommended its approval:

Printed Name	Function	Department
Mark Willett	RF System Prime	2M60
Lorne Thompson	BTS System Prime	2M69
Thomas Wong	CDMA/TDMA Regulatory Prime	2U40
Ryan Santa	Cell Site Systems (DOM prime)	2M42
James Loo	Cell Site Systems	2M64

Decision Maker

Ratifier's Name	Signature	Date
Thomas Wong	Thomas Wong	February 11, 2004

Decision Ratifier

The release of this document has been reviewed and approved for distribution and use by the following:

Ratifier's Name	Signature	Date
Tom Danshin	Tom Danshin	February 11, 2004

Revision History

Stream/Issue	Revision Date	Reason for Change	Author
00/1.0	11/02/2004	Document Approved	Lorne Thompson

Change bars will not be used in this document..

Acronyms and Abbreviations

ASIC	Application Specific Integrated Circuit
BBW	Breathing, Blossoming and Wilting
BPF	Bandpass Filter
BTS	Base Station Transceiver Subsystem
BW	Bandwidth
CDMA	Code Division Multiple Access
CR	Cost Reduced
dBFS	dB relative to Full Scale
DDS	Direct Digital Synthesizer
DPM	Duplexer Preselector Module
EEPROM	Electrically Erasable and Programmable ROM
EC	Engineering Change
ERLCE	Excess Reverse Link Capacity Estimate
HSSPC	High-Speed Serial Protocol Controller
HW	Hardware
IF	Intermediate Frequency
IIC	Inter-Integrated Circuit Bus
IS	Interim Standard
LO	Local Oscillator
LPF	Lowpass Filter
MFRM-2	Multi-Carrier Flexible Radio Module
MTRM	Multi-Carrier Transmitter Receiver Module
NF	Noise Figure
OCNS	Orthogonal Channel Noise Source
OH	OverHead
PA	Power Amplifier
PC	Personal Computer
PPR	Peak Power Reduction
PSA	Product Specification Agreement
RBW	Resolution BandWidth

RF	Radio Frequency
Rx	Receive
SA	Spectrum Analyzer
SFRM	Single Carrier Flexible Radio Module
SW	Software
TBD	To Be Determined
TM	Triplexer Module
TPTL	Transmit Power Tracking Loop
TRM	Transmitter Receiver Module
Tx	Transmit
uP	Microprocessor
XCVR	Transceiver

1 Introduction

This test report supports FCC filing for MFRM-2 8th and 9th carriers; This test report will be used as a new filing for FCC part 22. This filing includes single, two and three carrier modes for the 800MHz cellular band. The following test results include; RF Power Output, Occupied Bandwidth, Spurious Emissions at Antenna Terminals, and Transmitter Test (CDMA Mode Transmitter). Frequency over voltage and temperature test results are included. Emissions testing was conducted at -48VDC at room temperature. Both IS95 and IS856 modulation schemes will be included in this report.

This test report is submitted in accordance with the FCC Rules and Regulations, Part 2, Subpart J, Sections 2.1046 through 2.1057 for equipment authorization of Nortel Networks' CDMA 800 MHz Multi carrier Flexible Radio Module 2 (MFRM2).

The 800 MHz MFRM2 is intended for use in the Domestic Public Cellular Radio Telecommunications Service and is designed in accordance with the following standards:

- *CFR 47, Part 22, Subpart H, Cellular Radiotelephone Service [1]*
- *CFR 47, Part 2, Subpart J, Equipment Authorization Procedures - Equipment Authorization[2]*
- *IC RSS-129, Issue 2, 800 MHz Dual-Mode CDMA Cellular Telephones [3]*
- *TIA/EIA-97-D, Recommended Minimum Performance Standards for Base Stations Supporting Dual Mode Spread Spectrum Systems [4]*

1.1 Required Tests

Table 1 summarizes the required tests for the CDMA 800 MHz MFRM.

Table 1 : Required Tests

FCC Measurement Specification	FCC Limit Specification	Description	Test to be Performed?
2.1046	22.913	RF Power Output	Yes
2.1049	22.917	Occupied Bandwidth	Yes
2.1051, 2.1057	22.917	Spurious Emissions at Antenna Terminals	Yes
2.1053, 2.1057	22.917	Field Strength of Spurious Emissions	Yes ^a
2.1055		Frequency Stability	Yes

a. Field strength of spurious emissions testing will be performed by Sanmina-SCI Canada, Calgary.

2 Engineering Declaration

The CDMA 800MHz Multi carrier Flexible Radio Module2 has been tested in accordance with the requirements contained in the Federal Communications Commission Rules and Regulations Part 2 and 22.

To the best of my knowledge, these tests were performed in accordance with good engineering practices using measurement procedures consistent with industry or commission standards or previous Commission correspondence or guidance and demonstrate that this equipment complies with the appropriate standards. All tests were conducted on a representative sample of the equipment for which equipment authorization is sought.

Tested by: Lorne Thompson Systems Test Prime Nortel Networks Calgary Canada	 Signature	<u>February 9, 2004</u> Date
Reviewed by: Thomas Wong CDMA/TDMA Regulatory Emissions Prime Nortel Networks Calgary Canada	 Signature	<u>Feb 11, 2004</u> Date
Approved by: Tom Dannshin BTS System Manager Nortel Networks Calgary Canada	 Signature	<u>February 11, 2004</u> Date

3 Equipment Authorization Application Requirements

3.1 Standard Test Conditions and Test Equipment

The MFRM2 will be tested under the following standard test conditions unless otherwise noted:

- Ambient Temperature: 20 to 35 degrees C
- Ambient Humidity: 20 to 40%
- DC Supply Voltage: -48 Vdc and +24 Vdc (nominal)
- Input modulation IS-95 and IS-856 (16 QAM)

3.2 EUT Identification List

Table 2 shows the identification of the components required for testing.

Table 2 : EUT Identification List

Equipment Description	Model / Part Number	Release Number	Serial Number
800 MHz Multi carrier Flexible Radio Module	NTGY30AA	15	NNTM536FDXPT
800 DPM	NTGS89DB	06	CLWVMM1009GH
800 FAM	NTGS5652	N1	NNTM533GR5AX
DC Power Cable	NTGS8082	N/A	N/A
Fiber Cable	NTGY5520	N/A	N/A
DPM Power/Data Cable	NTGS5503	N/A	N/A
DPM to RX0 Cable	NTGS8069	N/A	N/A
DPM to RX1 Cable	NTGS8069	N/A	N/A

3.3 Test Equipment List

Table 3 shows the identification of the test equipment required.

Table 3 : Test Equipment List

Description	Manufacturer	Model	Serial Number	Cal. Due Date
9kHz to 40 GHz Spectrum Analyzer	Rohde&Schwarz	FSEK-30	DE25178	17 MAY 2004
RF Power Meter	Agilent	E4419B	US38260822	6 DEC 2005
RF Power Sensor Head	Agilent	E9300A	US39210633	23 APR 04
30dB Attenuator (>100W)	Weinschel	40-30-43	KL694	n/a
RF Cable 1 24"	Nortel	A0734233	n/a	n/a
RF Cable 2 8m Helix	Nortel	A0803065	n/a	n/a

4 Transmitter Tests

4.1 RF Power Output

4.1.1 RF Power Output Requirements

FCC Part 2.1046 Measurements required: RF power output

§(a) For transmitters other than single sideband, independent sideband and controlled carrier radiotelephone, power output shall be measured at the RF output terminals when the transmitter is adjusted in accordance with the tune-up procedure to give the values of current and voltage on the circuit elements specified in §2.1033(c)(8). The electrical characteristics of the radio frequency load attached to the output terminals when this test is made shall be stated.

(c) For measurements conducted pursuant to paragraphs (a) and (b) of this section, all calculations and methods used by the applicant for determining carrier power or peak envelope power, as appropriate, on the basis of measured power in the radio frequency load attached to the transmitter output terminals shall be shown. Under the test conditions specified, no components of the emission spectrum shall exceed the limits specified in the applicable rule parts as necessary for meeting occupied bandwidth or emission limitations.

4.1.2 Test Method

Setup the DE via the BTS controller to enable the MFRM2 to transmit at the rated power for each of the carrier configurations one, two and three carrier in each of the Baseband modulation formats IS-95 and IS-856 (16 QAM). Measurements will be made on channels at the bottom and top of the operator bands with the MFRM-2 operating with -48Vdc. The RF output power will be measured using the power meter.

4.1.3 Test Setup

The set-up required for the MFRM2 RF output power test is illustrated in Figure 1. RF output power measurements will be referenced to the antenna port of the DPM

4.1.4 DOM

The conducted spurious emissions of the MFRM-2, with IS-856 (1xEV DO) waveforms were tested at maximum power. Transmitters operating with IS856 are tested at +47.3 dBm.

4.1.5 Noise Floor

Table 4 lists the noise floor of the measurement system with no signal present.

Table 4: . Spectrum Analyzer Noise Floor

Start MHz	Stop MHz	Peak dBm
0.01	400	-42.18
400	1000	-39.44
1000	2000	-38.14
2000	3000	-36.83
3000	4000	-35.95
4000	5000	-36.09
5000	6000	-33.63
6000	7000	-29.57
7000	8000	-31.73
8000	9000	-31.97
9000	10000	-32.65

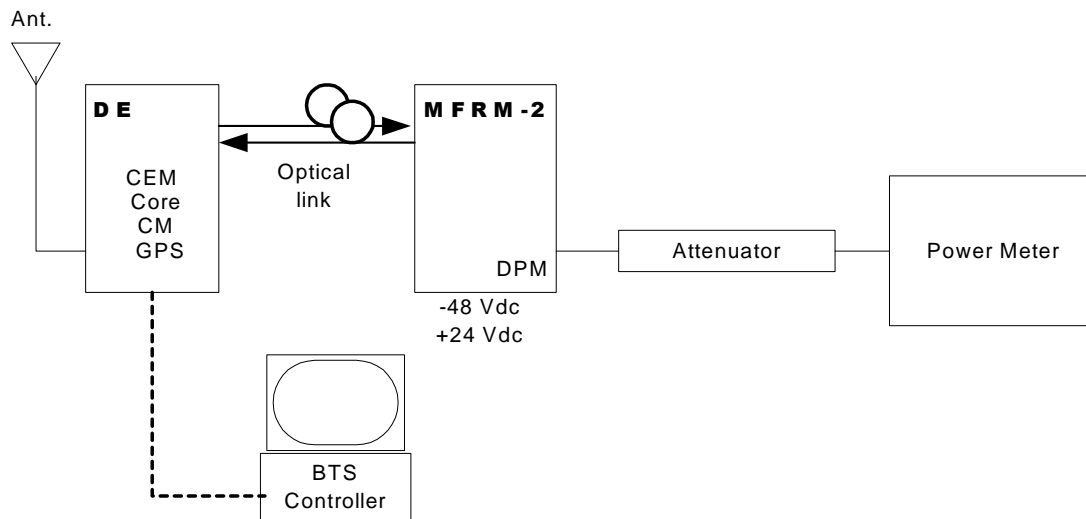

Figure 1 : Test Setup for RF Power Output Measurement

4.1.6 RF Output Power Test Results

Table 5 : RF Output Power 800 MHz MFRM2 1-Carrier IS95

Channel Number (Band)	Frequency (MHz)	Measured RF Output Power (dBm)	Maximum Rated Power (dBm)
1015 (A'')	869.76	47.30	47.3
308 (A)	879.24	47.31	47.3
358 (B)	880.74	47.31	47.3
642 (B)	889.26	47.34	47.3
692 (A')	890.76	47.32	47.3
742 (B')	892.26	47.34	47.3
775 (B')	893.25	47.30	47.3

Table 6 : RF Output Power 800 MHz MFRM2 2-Carrier IS95

Channel Number (Band)	Frequency (MHz)	Measured RF Output Power (dBm)	Maximum Rated Power (dBm)
1015, 33 (A'', A)	869.76, 870.99	47.33	47.3
267, 308 (A)	878.01, 879.24	47.31	47.3

Table 7 : RF Output Power of 800 MHz MFRM2 3-Carrier IS95

Channel Number (Band)	Frequencies (MHz)	Measured RF Output Power (dBm)	Maximum Rated Power (dBm)
1015, 33, 74 (A'', A)	869.76, 870.99, 872.22	47.34	47.3
226, 267, 308 (A)	876.78, 878.01, 879.24	47.35	47.3
358, 399, 440 (B)	880.74, 881.97, 883.20	47.30	47.3
560, 601, 642 (B)	886.8, 888.03, 889.26	47.34	47.3

Table 8 : RF Output Power 800 MHz MFRM2 1-Carrier IS856

Channel Number (Band)	Frequency (MHz)	Measured RF Output Power (dBm) 16-QAM	Maximum Rated Power (dBm)
1015 (A'')	869.76	47.31	47.3

Table 9 : RF Output Power of 800 MHz MFRM2 3-Carrier IS856

Channel Number (Band)	Frequencies (MHz)	Measured RF Output Power (dBm) 16-QAM	Maximum Rated Power (dBm)
1015, 33, 74 (A'', A)	869.76, 870.99, 872.22	47.32	47.3

Table 10: RF Output Power 800 MHz MFRM2 Combination 3-Carrier IS856 16-QAM 1015, 33 and IS95 chan 74

Channel Number (Band)	Frequencies (MHz)	Measured RF Output Power (dBm) 16-QAM and IS95	Maximum Rated Power (dBm)
1015, 33, 74 (A'')	869.76, 870.99, 872.22	47.30	47.3

4.2 Certification Requirements

4.2.1 Application for certification

FCC Part 2.1033 Application for certification.

(c) Applications for equipment other than that operating under parts 15 and 18 of the rules shall be accompanied by a technical report containing the following information:

(8) The dc voltages applied to and dc currents into the several elements of the final radio frequency amplifying device for normal operation over the power range.

4.2.2 Test Method

This information required for this section is available from:

Title: CDMA BTS Development, MFRM-2 800 MHz Power Amplifier Assembly Beta Cycle Verification Report
Dataset Name: NTGY37AA
Document Status: Ratified
Stream: 02 Issue: 02
Issue Date: March 12, 2003
Document Prime: Neil Claxton, 2M23

4.2.3 Test Setup

See above document

4.2.4 Test Results

The final amplifying dc voltage is 27.02 Vdc. The final dc current is

Table 11 : Average Current Values @ Pout = 48.45 dBm

Average Current Values @ Pout = 48.5 dBm				
22.5°C				
	Q4	Q5	Q6	Q7
Mean	3.63	4.03	3.82	3.92

4.3 Occupied Bandwidth

4.3.1 Occupied Bandwidth Requirements

FCC Part 2.1049

The OBW, that is the frequency bandwidth such that, below its lower and above its upper frequency limits, the mean powers radiated are each equal to 0.5 percent of the total mean power radiated by a given emission shall be measured under the following conditions as applicable:

(g) Transmitter in which the modulating baseband comprises not more than three independent channels - when modulated by the full complement of signals for which the transmitter is rated. The level of modulation for each channel should be set to that prescribed in rule parts applicable to the services for which the transmitter is intended. If specific modulation levels are not set forth in the rules, the tests should provide the manufacturer's maximum rated condition.

(h) Transmitters employing digital modulation techniques - when modulated by an input signal such that its amplitude and symbol rate represent the maximum rated conditions under which the equipment will be operated. The signal shall be applied through any filter networks, pseudo-random generators or other devices required in normal service. Additionally, the occupied bandwidth shall be shown for operation with any devices used for modifying the spectrum when such devices are optional at discretion of the user.

4.3.2 Test Method

Setup the DE via the BTS controller to enable the MFRM2 to transmit at maximum rated power for each of the carrier configurations one, two and three carrier in each of the Baseband modulation formats IS-95 and IS-856 (16 QAM). Measurements will be made on channels at the bottom and top of each of the operator bands.

A reference level is established by first using a resolution bandwidth that exceeds the signal bandwidth. RBW is then set to 1% of the estimated emission bandwidth and the video bandwidth is set to 3 times the resolution bandwidth. The markers are now moved to the -20 dB points (from the previously established reference level) on either side of centre frequency.

4.3.3 Test Setup

The set-up required for the MFRM2 Occupied bandwidth test is illustrated in Figure 2.

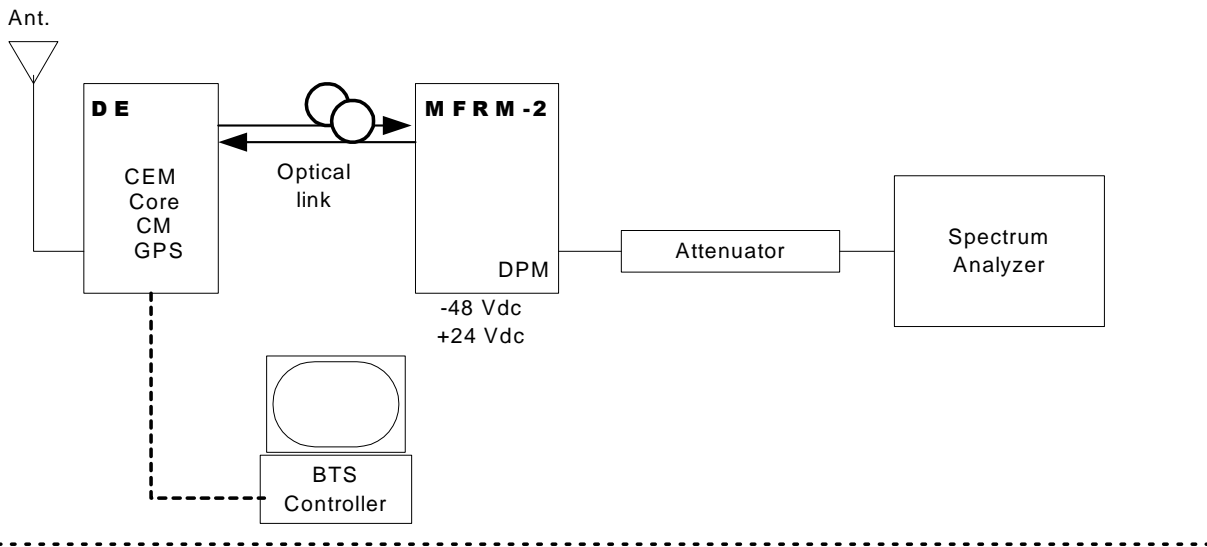

Figure 2 : Test Setup for Occupied Bandwidth Measurement

4.3.4 Test Result

Table 12 : Measured Occupied Bandwidth 800 MHz MFRM2 1-Carrier IS95

Channel Number (Band)	Frequency (MHz)	Measured Occupied Bandwidth (MHz) (1-Carrier)
1015 (A'')	869.76	1.258
308 (A)	879.24	1.258
358 (B)	880.8	1.254
642 (B)	889.26	1.258
692 (A')	890.76	1.254
742 (B')	892.26	1.254
775 (B')	893.25	1.255

Table 13 : Measured Occupied Bandwidth 800 MHz MFRM2 2-Carrier IS95

Channel Number (Band)	Frequency (MHz)	Measured Occupied Bandwidth (MHz)
1015, 33 (A', A)	869.76, 870.99	2.463
267, 308 (A)	878.01, 879.24	2.453

Table 14 : Measured Occupied Bandwidth of 800 MHz MFRM2 3-Carrier IS95

Channel Number (Band)	Frequencies (MHz)	Measured Occupied Bandwidth (kHz)
1015, 33, 74 (A', A)	869.76, 870.99, 872.22	3.671
226, 267, 308 (A)	876.78, 878.01, 879.24	3.671
358, 399, 440 (B)	880.74, 881.97, 883.20	3.671
560, 601, 642 (B)	886.8, 888.03, 889.26	3.671

Table 15 : Measured Occupied Bandwidth 800 MHz MFRM2 1-Carrier IS856 16-QAM

Channel Number (Band)	Frequency (MHz)	Measured Occupied Bandwidth (kHz)
1015 (A')	869.76	1.250
308 (A)	879.24	1.255

Table 16 : Measured Occupied Bandwidth 800 MHz MFRM2 3-Carrier IS856 16-QAM

Channel Number (Band)	Frequencies (MHz)	Measured Occupied Bandwidth (kHz)
1015, 33, 74 (A', A)	869.76, 870.99, 872.22	3.671

Table 17: Measured Occupied Bandwidth 800 MHz MFRM2 Combination 3-Carrier IS856

16-QAM 1015, 33 and IS95 chan 74

Channel Number (Band)	Frequencies (MHz)	Measured Occupied Bandwidth (kHz)
1015, 33, 74 (A'' A)	869.76, 870.99, 872.22	3.671

4.4 Spurious Emissions at Antenna Terminals

4.4.1 Spurious Emissions Requirements

FCC Part 2.1051

The radio frequency voltage or powers generated within the equipment and appearing on a spurious frequency shall be checked at the equipment output terminals when properly loaded with a suitable artificial antenna. Curves or equivalent data shall show the magnitude of each harmonic and other spurious emission that can be detected when the equipment is operated under the conditions specified in 2.1049 as appropriate. The magnitude of spurious emissions which are attenuated more than 20 dB below the permissible value need not be specified.

FCC Part 2.1057 - Frequency Spectrum to be investigated

The spectrum should be investigated from the lowest radio frequency generated in the equipment up to at least the 10th harmonic of the carrier frequency or to the highest frequency practicable in the present state of the art of measuring techniques, whichever is lower. Particular attention should be paid to harmonics and subharmonics of the carrier frequency. Radiation at the frequencies of multiplier stages should be checked. The amplitude of spurious emissions which are attenuated more than 20 dB below the permissible value need not be reported.

FCC Part 22.917 Limit

Out of band emissions. The power of any emission outside of the authorized operating frequency ranges must be attenuated below the transmitting power (P) by a factor of at least $43 + 10 \log(P)$ dB.

Measurement procedure. Compliance with these rules is based on the use of measurement instrumentation employing a resolution bandwidth of 100 kHz or greater. In the 1 MHz bands immediately outside and adjacent to the frequency block a resolution bandwidth of at least one percent of the emission bandwidth of the fundamental emission of the transmitter may be employed. A narrower resolution bandwidth is permitted in all cases to improve measurement accuracy provided the measured power is integrated over the full required measurement bandwidth (i.e. 100 kHz or 1 percent of emission bandwidth, as specified). The emission bandwidth is defined as the width of the signal between two points, one below the carrier center frequency and one above the carrier center frequency, outside of which all emissions are attenuated at least 26 dB below the transmitter power.

Alternative out of band emission limit. Licensees in this service may establish an alternative out of band emission limit to be used at specified band edge(s) in specified geographical areas, in lieu of that set forth in this section, pursuant to a private contractual arrangement of all affected licensees and applicants. In this event, each party to such contract shall maintain a copy of the contract in their station files and disclose it to prospective assignees or transferees and, upon request, to the FCC.

Interference caused by out of band emissions. If any emission from a transmitter operating in this service results in interference to users of another radio service, the FCC may require a greater attenuation of that emission than specified in this section

4.4.2 Test Method

Configure the BTS via the BTS controller to enable the MFRM2 to transmit at maximum rated power for each of the carrier configurations one, two and three carrier in each of the Baseband modulation formats IS-95, and IS-856 (16 QAM). Measurements will be made on channels at the bottom and top of the operator bands. The following spectrum analyzer settings are to be used for the measurement of the antenna port (DPM) spurious emissions:

4.4.2.1 Adjacent 1MHz to indicated cellular band (Upper and Lower)

Table 18: Adjacent 1MHz Spectrum Analyze Settings

Setting	1 Carrier	2 Carrier	3 Carrier
Resolution Bandwidth ^a :	12.5 kHz	25 kHz	37.5 kHz
Video Bandwidth (3x RBW) ^b	(3x RBW)	(3x RBW)	(3x RBW)
Video Average	10 Averages	10 Averages	10 Averages
Span	Set accordingly	Set accordingly	Set accordingly
Detector	RMS	RMS	RMS
Attenuation ^c	30 dB	30 dB	30 dB
Ref. Level	35 dBm	35 dBm	35 dBm
Ref. Level Offset	31-34 dB	31-34 dB	31-34 dB

- a. If the spectrum analyze cannot be set to the specified RBW the next highest RBW should be used and all measurements corrected to the specified RBW
- b. If the spectrum analyze cannot be set to the specified Video Bandwidth the next highest Video Bandwidth should be used.
- c. The lowest value of attenuator should be used to improve measurement accuracy, without overdriving the Spectrum Analyzer.

All spectrum analyzer settings were coupled as per the manufacturers recommendations to improve measurement time, without compromising data.

4.4.2.2 All other Spurious Emissions up to 10 GHz

Table 19 : All other Emission Spectrum Analyze Settings

Setting	1 Carrier	2 Carrier	3 Carrier
Resolution Bandwidth	100 kHz	100 kHz	100 kHz
Video Bandwidth (3x RBW)	300 kHz	300 kHz	300 kHz
Video Average	10 Averages	10 Averages	10 Averages
Span	Set accordingly	Set accordingly	Set accordingly
Detector	RMS	RMS	RMS
Attenuation ^a	30 dB	30 dB	30 dB
Ref. Level	35 dBm	35 dBm	35 dBm
Ref. Level Offset	31-34 dB	31-34 dB	31-34 dB

- a. The lowest value of attenuator should be used to improve measurement accuracy, without overdriving the Spectrum Analyzer.

The emissions will be investigated up to 10 GHz (the 10th harmonic of the fundamental emission) for all carrier configurations (1, 2, 3) as per FCC Part 22.

4.4.3 Test Requirements

Table 20: Spurious Emissions Requirements

Frequency Offset	1 Carrier	2 Carrier	3 Carrier
+/- 740 kHz	< -13 dBm/12.5KHz	< -13 dBm/25 KHz	< -13 dBm/37.5 KHz

4.4.4 Test Setup

The set-up required for the MFRM2 Antenna Port (DPM) Spurious Emission test is illustrated in Figure 3.

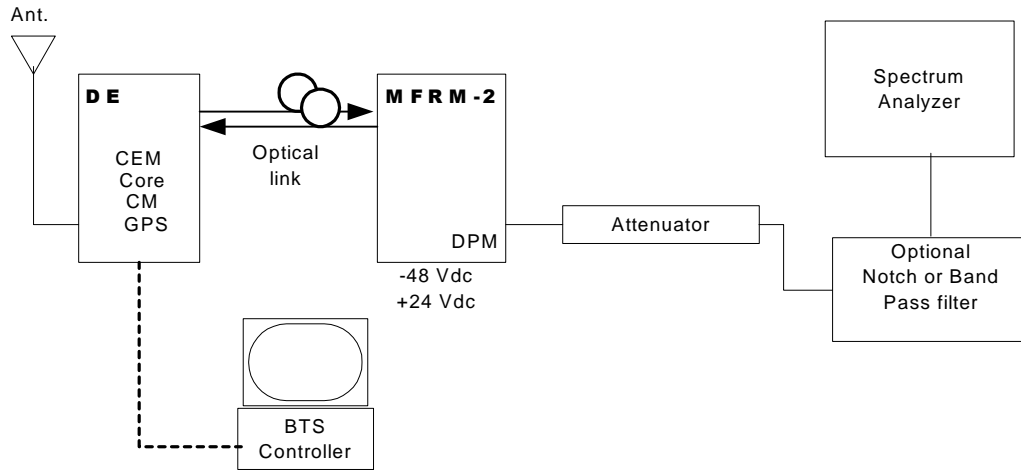

Figure 3 : Test Setup for Spurious Emissions Measurement

4.4.5 Test Results IS95

Table 21 : Spurious Emissions at the 800 MHz MFRM2 Ant. Port one Carrier band A and A'' IS95

Frequency (MHz)	Spurious Emissions Level (dBm)	Margin to FCC Limit of -13 dBm (dB)
	1Carrier IS-95	1Carrier
869 MHz (Lower edge of band A'') Ch 1015 (RBW=12.5 kHz)	-26.04	13.04
880 MHz (Upper edge of band A) Ch 308 (RBW=12.5 kHz)	-27.23	14.23
0-1000 (RBW=100KHz)	-28.24	15.24
1000-2000 (RBW=100KHz)	-27.62	14.62
2000-3000 (RBW=100KHz)	-35.98	22.98
3000-4000 (RBW=100KHz)	-35.50	22.5
4000-5000 (RBW=100KHz)	-35.39	22.39
5000-6000 (RBW=100KHz)	-32.66	19.66
6000-7000 (RBW=100KHz)	-29.38	16.38
7000-8000 (RBW=100KHz)	-31.04	18.04
8000-9000 (RBW=100KHz)	-31.29	18.29
9000-10000 (RBW=100KHz)	-32.03	19.03

Table 22 : Spurious Emissions at the 800 MHz MFRM2 Ant. Port two Carrier band A and A'' IS95

Frequency (MHz)	Spurious Emissions Level (dBm)	Margin to FCC Limit of -13 dBm (dB)
	2Carrier IS-95	2Carrier
869.000 MHz (Lower edge of band A'') Ch 1015, 33 (RBW=25kHz)	-26.10	13.10
880 MHz (upper edge of band A) Ch 267, 308 (RBW=25kHz)	-28.83	15.83
0-1000 (RBW=100KHz)	-23.10	10.10
1000-2000 (RBW=100KHz)	-30.68	17.68
2000-3000 (RBW=100KHz)	-37.11	24.11
3000-4000 (RBW=100KHz)	-36.10	23.1
4000-5000 (RBW=100KHz)	-36.26	23.26
5000-6000 (RBW=100KHz)	-33.94	20.94
6000-7000 (RBW=100KHz)	-30.10	17.1
7000-8000 (RBW=100KHz)	-32.01	19.01
8000-9000 (RBW=100KHz)	-32.04	19.04
9000-10000 (RBW=100KHz)	-32.88	19.88

Table 23 : Spurious Emissions at the 800 MHz MFRM2 Ant. Port Three Carrier band A and A'' IS-95

Frequency (MHz)	Spurious Emissions Level (dBm)	Margin to FCC Limit of -13 dBm (dB)
	3Carrier IS-95	3Carrier
869 MHz (Lower edge of band A'') Ch 1015, 33, 74 (RBW=37.5 kHz)	-26.35	13.35
880 MHz (Upper edge of band A) Ch 226, 267, 308 (RBW=37.5 kHz)	-28.48	15.48
0-1000 (RBW=100KHz)	-24.53	11.53
1000-2000 (RBW=100KHz)	-32.24	19.24
2000-3000 (RBW=100KHz)	-37.10	24.10
3000-4000 (RBW=100KHz)	-36.08	23.08
4000-5000 (RBW=100KHz)	-36.37	23.37
5000-6000 (RBW=100KHz)	-33.85	20.85
6000-7000 (RBW=100KHz)	-29.85	16.85
7000-8000 (RBW=100KHz)	-31.93	18.93
8000-9000 (RBW=100KHz)	-32.23	19.23
9000-10000 (RBW=100KHz)	-32.98	19.98

Table 24 : Spurious Emissions at the 800 MHz MFRM2 Ant. Port One Carrier band B IS-95

Frequency (MHz)	Spurious Emissions Level (dBm)	Margin to FCC Limit of -13 dBm (dB)
	1Carrier IS-95	1Carrier
880 MHz (Lower edge of band B) Ch 358 (RBW=12.5kHz)	-23.62	10.62
890 MHz (Upper edge of band B) Ch 642 (RBW=12.5kHz)	-24.05	11.05
0-1000 (RBW=100KHz)	-34.17	21.17
1000-2000 (RBW=100KHz)	-30.18	17.18
2000-3000 (RBW=100KHz)	-36.96	23.96
3000-4000 (RBW=100KHz)	-36.46	23.46
4000-5000 (RBW=100KHz)	-36.30	23.30
5000-6000 (RBW=100KHz)	-32.70	19.70
6000-7000 (RBW=100KHz)	-29.42	16.42
7000-8000 (RBW=100KHz)	-31.18	18.18
8000-9000 (RBW=100KHz)	-31.47	18.47
9000-10000 (RBW=100KHz)	-32.06	19.06

Table 25 : Spurious Emissions at the 800 MHz MFRM2 Ant. Port Three Carrier band B IS-95

Frequency (MHz)	Spurious Emissions Level (dBm)	Margin to FCC Limit of -13 dBm (dB)
	3Carrier IS-95	3Carrier
880 MHz (Lower edge of band B) Ch 358, 399, 440 (RBW=37.5 kHz)	-25.85	12.85
890 MHz (Upper edge of band B) Ch 560, 601, 642 (RBW=37.5 kHz)	-26.11	13.11
0-1000 (RBW=100KHz)	-25.32	12.32
1000-2000 (RBW=100KHz)	-34.26	21.26
2000-3000 (RBW=100KHz)	-37.10	24.10
3000-4000 (RBW=100KHz)	-38.34	25.34
4000-5000 (RBW=100KHz)	-36.68	23.68
5000-6000 (RBW=100KHz)	-33.77	20.77
6000-7000 (RBW=100KHz)	-29.66	16.66
7000-8000 (RBW=100KHz)	-31.93	18.93
8000-9000 (RBW=100KHz)	-32.44	19.44
9000-10000 (RBW=100KHz)	-33.04	20.04

Table 26 : Spurious Emissions at the 800 MHz MFRM2 Ant. Port One Carrier band A' IS-95

Frequency (MHz)	Spurious Emissions Level (dBm)	Margin to FCC Limit of -13 dBm (dB)
	1 Carrier IS-95	1 Carrier
890 Mhz (Lower edge of band A') Ch 692(RBW=12.5 kHz)	-27.38	14.38
891.5 MHz (upper edge of band A') Ch 692 (RBW=12.5kHz)	-24.85	11.85
0-1000 (RBW=100KHz)	-33.19	20.19
1000-2000 (RBW=100KHz)	-33.66	20.66
2000-3000 (RBW=100KHz)	-39.15	26.15
3000-4000 (RBW=100KHz)	-38.84	25.84
4000-5000 (RBW=100KHz)	-37.61	24.61
5000-6000 (RBW=100KHz)	-33.93	20.93
6000-7000 (RBW=100KHz)	-29.21	16.21
7000-8000 (RBW=100KHz)	-33.76	20.76
8000-9000 (RBW=100KHz)	-33.4	20.40
9000-10000 (RBW=100KHz)	-34.18	21.18

Table 27 : Spurious Emissions at the 800 MHz MFRM2 Ant. Port One Carrier band B' IS95

Frequency (MHz)	Spurious Emissions Level (dBm)	Margin to FCC Limit of -13 dBm (dB)
	1 Carrier IS-95	1 Carrier
894 MHz (upper edge of band B') Ch 775 (RBW=12.5kHz)	-25.02	12.02
891.5 MHz (lower edge of band B') Ch 742 (RBW=12.5kHz)	-26.6	13.6
0-1000 (RBW=100KHz)	-32.36	19.36
1000-2000 (RBW=100KHz)	-30.64	17.64
2000-3000 (RBW=100KHz)	-36.90	23.90
3000-4000 (RBW=100KHz)	-35.07	22.07
4000-5000 (RBW=100KHz)	-35.08	22.08
5000-6000 (RBW=100KHz)	-32.96	19.96
6000-7000 (RBW=100KHz)	-29.32	16.32
7000-8000 (RBW=100KHz)	-31.40	18.40
8000-9000 (RBW=100KHz)	-31.33	18.33
9000-10000 (RBW=100KHz)	-32.19	19.19

4.4.6 Test Results IS856

Table 28 : Spurious Emissions at the 800 MHz MFRM2 Ant. Port One Carrier Band A and A'' IS856

Frequency (MHz)	Spurious Emissions Level (dBm)	Margin to FCC Limit of -13 dBm (dB)
	1 Carrier 16-QAM	1 Carrier
869 (Lower edge of band A'') Ch 1015 (RBW=12.5kHz)	-28.15	15.15
880 (Upper edge of band A) Ch Ch 308 (RBW=12.5kHz)	-29.23	16.23
0-1000 (RBW=100KHz)	-29.90	16.90
1000-2000 (RBW=100KHz)	-30.66	17.66
2000-3000 (RBW=100KHz)	-37.13	24.13
3000-4000 (RBW=100KHz)	-36.21	23.21
4000-5000 (RBW=100KHz)	-36.14	23.14
5000-6000 (RBW=100KHz)	-33.69	20.69
6000-7000 (RBW=100KHz)	-30.02	17.02
7000-8000 (RBW=100KHz)	-32.07	19.07
8000-9000 (RBW=100KHz)	-32.20	19.20
9000-10000 (RBW=100KHz)	-33.03	20.03

Table 29: Spurious Emissions at the 800 MHz MFRM2 Ant. Port Three Carrier Band A and A'' IS856

Frequency (MHz)	Spurious Emissions Level (dBm)	Margin to FCC Limit of -13 dBm (dB)
	3Carrier 16-QAM	3Carrier
869 (Lower edge of band A'') Ch Ch1015, 33, 74 (RBW=37.5 kHz)	-29.11	16.11
880 (Upper edge of band A) Ch Ch 226, 267, 308 (RBW=37.5 kHz)	-28.54	15.54
0-1000 (RBW=100KHz)	-21.45	8.45
1000-2000 (RBW=100KHz)	-32.89	19.89
2000-3000 (RBW=100KHz)	-36.92	23.92
3000-4000 (RBW=100KHz)	-36.31	23.31
4000-5000 (RBW=100KHz)	-36.36	23.36
5000-6000 (RBW=100KHz)	-33.51	20.51
6000-7000 (RBW=100KHz)	-29.71	16.71
7000-8000 (RBW=100KHz)	-32.20	19.20
8000-9000 (RBW=100KHz)	-32.28	19.28
9000-10000 (RBW=100KHz)	-32.97	19.97

Table 30: Spurious Emissions at the 800 MHz MFRM2 Ant. Port Three Carrier Band A and A'' Combined IS95 (Ch 74) and IS856 (Ch 1015 and 33)

Frequency (MHz)	Spurious Emissions Level (dBm)	Margin to FCC Limit of -13 dBm (dB)
	3Carrier 16-QAM	3Carrier
869 (Lower edge of band A'') Ch Ch1015, 33, 74 (RBW=37.5 kHz)	-27.72	14.72
0-1000 (RBW=100KHz)	-27.59	14.59
1000-2000 (RBW=100KHz)	-21.16	8.16
2000-3000 (RBW=100KHz)	-37.11	24.11
3000-4000 (RBW=100KHz)	-36.20	23.20
4000-5000 (RBW=100KHz)	-36.65	23.65
5000-6000 (RBW=100KHz)	-34.03	21.03
6000-7000 (RBW=100KHz)	-30.03	17.03
7000-8000 (RBW=100KHz)	-32.05	19.05
8000-9000 (RBW=100KHz)	-32.18	19.18
9000-10000 (RBW=100KHz)	-33.00	20.00

4.5 Transmitter Tests (CDMA Mode)

Unwanted Emissions

Unwanted emissions are emissions on a frequency or frequencies outside the necessary bandwidth which result from the modulation process, from spurious emissions and harmonics.

IC RSS-129

(1) Suppression inside cellular band: For all base station transmit frequencies allocated to the same operator system, the total spurious emissions in any 30 kHz band shall be attenuated below the mean output power level in accordance with the following schedule:

(a) for all offset frequencies greater than 750 kHz from the CDMA centre frequency, at least 45 dB. 800 MHz Dual-Mode CDMA Cellular Telephones RSS-129.

(b) for all offset frequencies greater than 1.98 MHz from the CDMA centre frequency, at least 60 dB.

(c) for all offset frequencies not allocated to the same operator system, at least 60 dB or -13 dBm, whichever is less stringent.

(2) In any 30 kHz outside the cellular band, the attenuation shall be at least $43+10 \log_{10}$ (mean output power in watts) or 70, dB, whichever is the less stringent.

4.5.1 Test Method

Configure the BTS via the BTS controller to enable the MFRM2 to transmit at maximum rated power for each of the carrier configurations one, two and three carrier in each of the Baseband modulation formats IS-95, and IS-856 (16 QAM). Measurements will be made on channels at the bottom and top of the duplexer band. The following spectrum analyzer settings are to be used for the measurement of the antenna port (DPM) spurious emissions:

4.5.1.1 Adjacent 1MHz to indicated cellular band (Upper and Lower)

Table 31: Adjacent 750 KHz and 1.98 MHz Spectrum Analyze Settings

Setting	1 Carrier	2 Carrier	3 Carrier
Resolution Bandwidth ^a :	30 kHz	30 kHz	30 kHz
Video Bandwidth (3x RBW)	100 kHz	100 kHz	100 kHz
Video Average	10 Averages	10 Averages	10 Averages
Span	Set accordingly	Set accordingly	Set accordingly
Detector	RMS	RMS	RMS
Attenuation	30 dB	30 dB	30 dB
Ref. Level	35 dBm	35 dBm	35 dBm
Ref. Level Offset	31-34 dB	31-34 dB	31-34 dB

a. If the spectrum analyze can not be set to the specified RBW the next highest RBW should be used and all measurements corrected to the specified RBW

All spectrum analyzer settings were coupled as per the manufacturers recommendations to improve measurement time, without compromising data.

4.5.2 Test Setup

The set-up required for the MFRM2 Antenna Port (DPM) Spurious Emission test is illustrated in Figure 3. An optional filter may be used to improve the measurement set-up. If a filter is used it must be clearly stated in the test results, and the frequency response of the filter must also be recorded and presented in the results data.

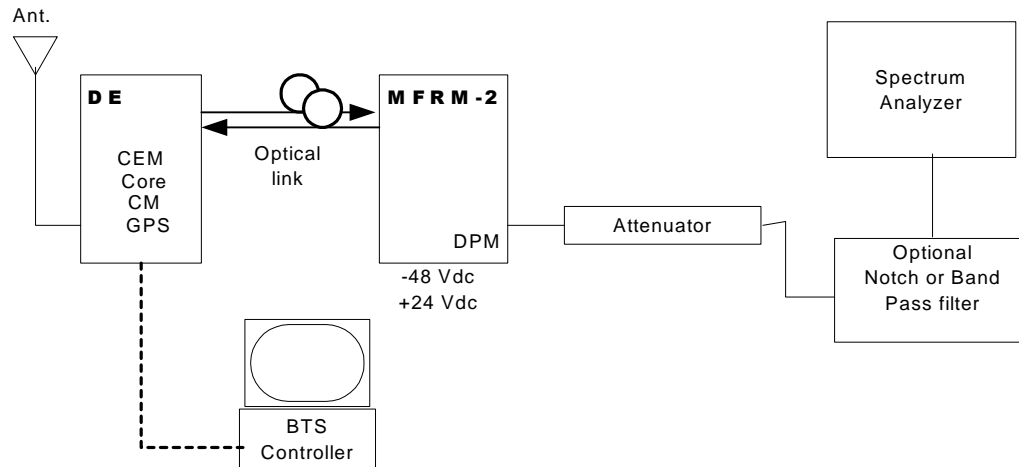

Figure 4 : Test Setup for Spurious Emissions Measurement

4.5.3 Test Results

Table 32 : Industry Canada Suppression inside cellular band 800 MHz MFRM2 Antenna Port IS95, 1 Carrier band A”

Frequency (MHz)	Spurious Emissions Level (dBm)	Limit for 45 dBc/ 30KHz (dB)	Margin to IC Limit of 45 dBc/ 30KHz (dB)
	1Carrier IS-95	1Carrier	
Ch1015 750KHz offset at lower band edge	-19.12	2.3	21.42
Ch1015 750KHz offset at upper band edge	-20.84	2.3	23.14
		Limit for 60 dBc/ 30KHz (dB)	Margin to IC Limit of 60 dBc/ 30KHz (dB)
Ch1015 1.98MHz offset at lower band edge	-41.75	-12.7	29.05
Ch1015 1.89MHz offset at upper band edge	-40.93	-12.7	28.23

Table 33 : Industry Canada Suppression inside cellular band 800 MHz MFRM2 Antenna Port IS95, 3 Carrier band A'' and A

Frequency (MHz)	Spurious Emissions Level (dBm)	Limit for 45 dBc/ 30KHz (dB)	Margin to IC Limit of 45 dBc/ 30KHz (dB)
	3Carrier IS-95	3Carrier	3Carrier
Ch1015, 33, 74 750KHz offset at lower band edge	-22.66	2.3	24.96
Ch1015, 33, 74 750KHz offset at upper band edge	-23.76	2.3	26.06
		Limit for 60 dBc/ 30KHz (dB)	Margin to IC Limit of 60 dBc/ 30KHz (dB)
Ch1015, 33, 74 1.98MHz offset at lower band edge	-39.94	-12.7	27.24
Ch1015, 33, 74 1.98MHz offset at upper band edge	-32.64	-12.7	19.94

Table 34 : Industry Canada Suppression inside cellular band 800 MHz MFRM2 Antenna Port IS856, 1 Carrier band A'

Frequency (MHz)	Spurious Emissions Level (dBm)	Limit for 45 dBc/ 30KHz (dB)	Margin to IC Limit of 45 dBc/ 30KHz (dB)
	1Carrier IS856 16- QAM	1Carrier	1Carrier
Ch 1015 750KHz offset at lower band edge	-20.08	2.3	22.38
Ch 1015 750KHz offset at upper band edge	-21.89	2.3	24.19
		Limit for 60 dBc/ 30KHz (dB)	Margin to IC Limit of 60 dBc/ 30KHz (dB)
Ch 1015 1.98MHz offset at lower band edge	-43.97	-12.7	31.27
Ch 1015 1.98MHz offset at upper band edge	-40.84	-12.7	28.14

Table 35 : Industry Canada Suppression inside cellular band 800 MHz MFRM2 Antenna Port IS95, 1 Carrier band B'

Frequency (MHz)	Spurious Emissions Level (dBm)	Limit for 45 dBc/ 30KHz (dB)	Margin to IC Limit of 45 dBc/ 30KHz (dB)
	1Carrier IS-95	1Carrier	1Carrier
Ch 742 750KHz offset at lower band edge	-19.97	2.3	22.27
Ch 742 750KHz offset at upper band edge	-19.77	2.3	22.07
		Limit for 60 dBc/ 30KHz (dB)	Margin to IC Limit of 60 dBc/ 30KHz (dB)
Ch 742 1.98MHz offset at lower band edge	-41.33	-12.7	28.63
Ch 742 1.98MHz offset at upper band edge	-41.54	-12.7	28.84

Table 36 : Industry Canada Suppression inside cellular band 800 MHz MFRM2 Antenna Port Combination IS856(1015,33) and IS95 (74) 3 Carrier band A and A''

Frequency (MHz)	Spurious Emissions Level (dBm)	Limit for 45 dBc/ 30KHz (dB)	Margin to IC Limit of 45 dBc/ 30KHz (dB)
	1Carrier IS-95	1Carrier	1Carrier
Ch 1014, 33, 74 750KHz offset at lower band edge	-23.67	2.3	25.97
Ch 1014, 33, 74 750KHz offset at upper band edge	-24.45	2.3	26.75
		Limit for 60 dBc/ 30KHz (dB)	Margin to IC Limit of 60 dBc/ 30KHz (dB)
Ch 1014, 33, 74 1.98MHz offset at lower band edge	-37.08	-12.7	24.38
Ch 1014, 33, 74 1.98MHz offset at upper band edge	-29.90	-12.7	17.2

4.6 Frequency Stability

4.6.1 Frequency Stability Requirements

FCC Part 2.1055

(a) The frequency stability shall be measured with variation of ambient temperature as follows:

(1) From -30 to +50 centigrade for all equipment except that specified in subparagraphs (2) and (3) of this paragraph.

(b) Frequency measurements shall be made at the extremes of the specified temperature range and at intervals of not more than 10 centigrade through the range. A period of time sufficient to stabilize all of the components of the oscillator circuit at each temperature level shall be allowed prior to frequency measurement. The short term transient effects on the frequency of the transmitter due to keying (except for broadcast transmitters) and any heating element cycling normally occurring at each ambient temperature level also shall be shown. Only the portion or portions of the transmitter containing the frequency determining and stabilizing circuitry need be subjected to the temperature variation test.

(d) The frequency stability shall be measured with variation of primary supply voltage as follows:

(1) Vary primary supply voltage from 85 to 115 percent of the nominal value for other than hand carried battery equipment.

(2) For hand carried, battery powered equipment, reduce primary supply voltage to the battery operating end point which shall be specified by the manufacturer.

(3) The supply voltage shall be measured at the input to the cable normally provided with the equipment, or at the power supply terminals if cables are not normally provided. Effects on frequency of transmitter keying (except for broadcast transmitters) and any heating element cycling at the nominal supply voltage and at each extreme also shall be shown.

(e) When deemed necessary, the Commission may require tests of frequency stability under conditions in addition to those specifically set out in paragraphs (a), (b), (c) and (d) of this section. (For example, measurements showing the effect of proximity to large metal objects, or of various types of antennas, may be required for portable equipment.)

FCC Part 22.355 Frequency Tolerance

The carrier frequency of each transmitter in the 821-896 MHz Frequency range, must be maintained within 1.5ppm tolerance, according to table C-1 of this section stability

4.6.2 Test Procedure

The test equipment was configured as shown in figure 5.

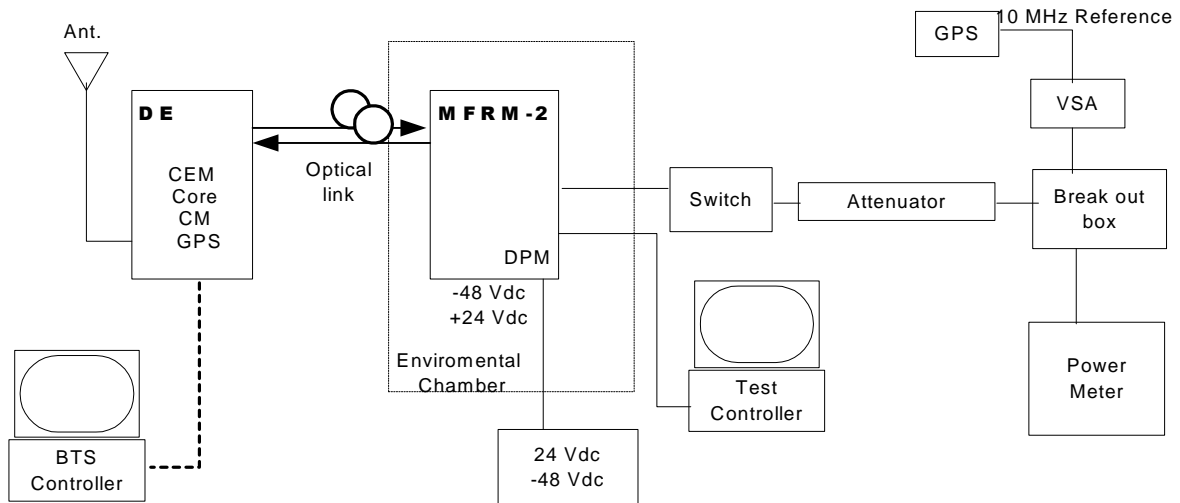

Figure 5 : Test configuration for Frequency Stability

4.6.3 Frequency Results

Table 37 : Test results for Frequency Stability versus Power supply Voltage

Voltage (Vdc)	Maximum Carrier Frequency Deviation (PPM)	Maximum Carrier Frequency Deviation (Hz)
40	0.0025	-2.2
48 nominal	0.0034	-3
56	0.0053	4.6
20	0.0029	2.5
24 nominal	0.0013	1.2

Table 37 : Test results for Frequency Stability versus Power supply Voltage

Voltage (Vdc)	Maximum Carrier Frequency Deviation (PPM)	Maximum Carrier Frequency Deviation (Hz)
28	0.0015	1.33

Table 38 : Test results for Frequency Stability versus Temperature at -48V operation

Temperature (°C)	Maximum Carrier Frequency Deviation (PPM)	Maximum Carrier Frequency Deviation (Hz)
-30	0.0027	-2.31
-20	0.0038	3.27
-10	0.0044	-3.85
0	0.0065	-5.68
10	.0044	4.29
20	0.0049	3.11
30	0.0036	3.12
40	0.0036	5.06
50	0.0058	-1.41

Table 39 : Test results for Frequency Stability versus Temperature at 24V operation

Temperature (°C)	Maximum Carrier Frequency Deviation (PPM)	Maximum Carrier Frequency Deviation (Hz)
-30	0.0063	-5.47
-20	0.0031	2.67
-10	0.0058	5.07
0	0.0044	3.86
10	0.0048	4.17
20	0.0007	-0.65
30	0.0036	-3.11
40	0.0023	-1.99
50	0.0049	-4.25

References

- [1] FCC Part 22 Subpart H, “Public Mobile Services”, http://www.access.gpo.gov/nara/cfr/waisidx_01/47cfr22_01.html
- [2] FCC Part 2 Subpart J, “Frequency allocations and radio treaty matters; general rules and regulations”, http://www.access.gpo.gov/nara/cfr/waisidx_01/47cfr2_01.html
- [3] Industry Canada RSS-129, “800 MHz Dual-Mode CDMA Cellular Telephones”, <http://strategis.ic.gc.ca/SSG/sf01324e.html>
- [4] TIA/EIA-97-D “Recommended Minimum Performance Standards for Base Stations Supporting Dual Mode Spread Spectrum Systems”, June 2001
- [5] Industry Canada “Information on the 99% Bandwidth measurement” Author Brian Kasper. [http://strategis.ic.gc.ca/epic/internet/inceb-bhst.nsf/vwapj/occupied-bandwidth.pdf/\\$FILE/occupied-bandwidth.pdf](http://strategis.ic.gc.ca/epic/internet/inceb-bhst.nsf/vwapj/occupied-bandwidth.pdf/$FILE/occupied-bandwidth.pdf)
- [6] CDMA BTS Developmen, MFRM-2 800 MHz Power Amplifier Assembly Beta Cycle Verification Report, Dataset Name: NTGY37AA, Document Status: Ratified, Stream: 02 Issue: 02, Issue Date: March 12, 2003, Document Prime: Neil Claxton, 2M23

APPENDIX PLOTS

**Single Chan 1015 IS95 Spurious Emissions at the 800 MHz MFRM2 Ant. Port one
Carrier band A and A'' IS95**

Occupied Bandwidth Ch 1015 A''

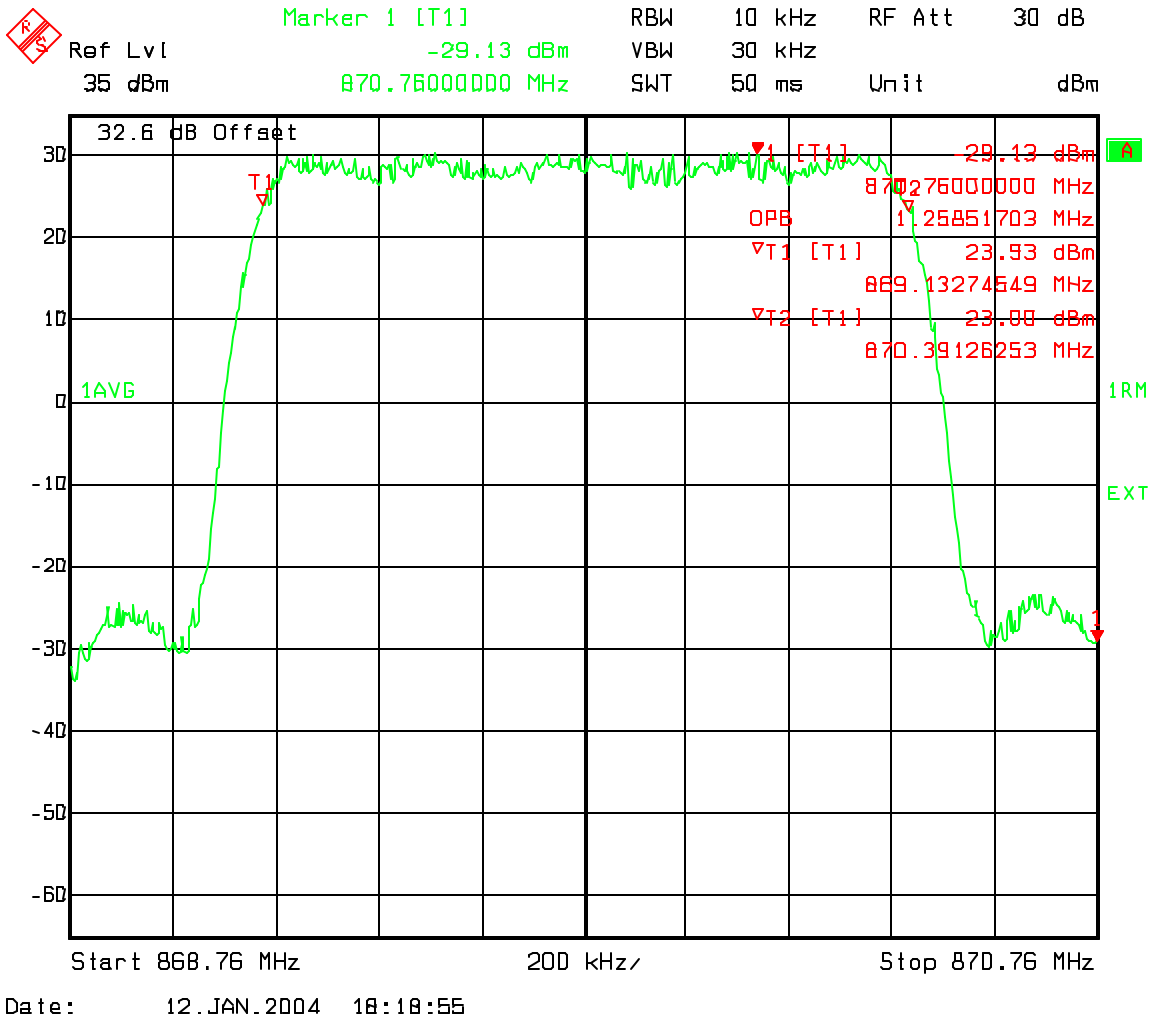

**Single Chan 1015 IS95 Spurious Emissions at the 800 MHz MFRM2 Ant. Port one
Carrier band A and A'' IS95**

A'' Band Ch 1015 IS95 Adjacent 1Mhz Lower emissions 868-869MHz

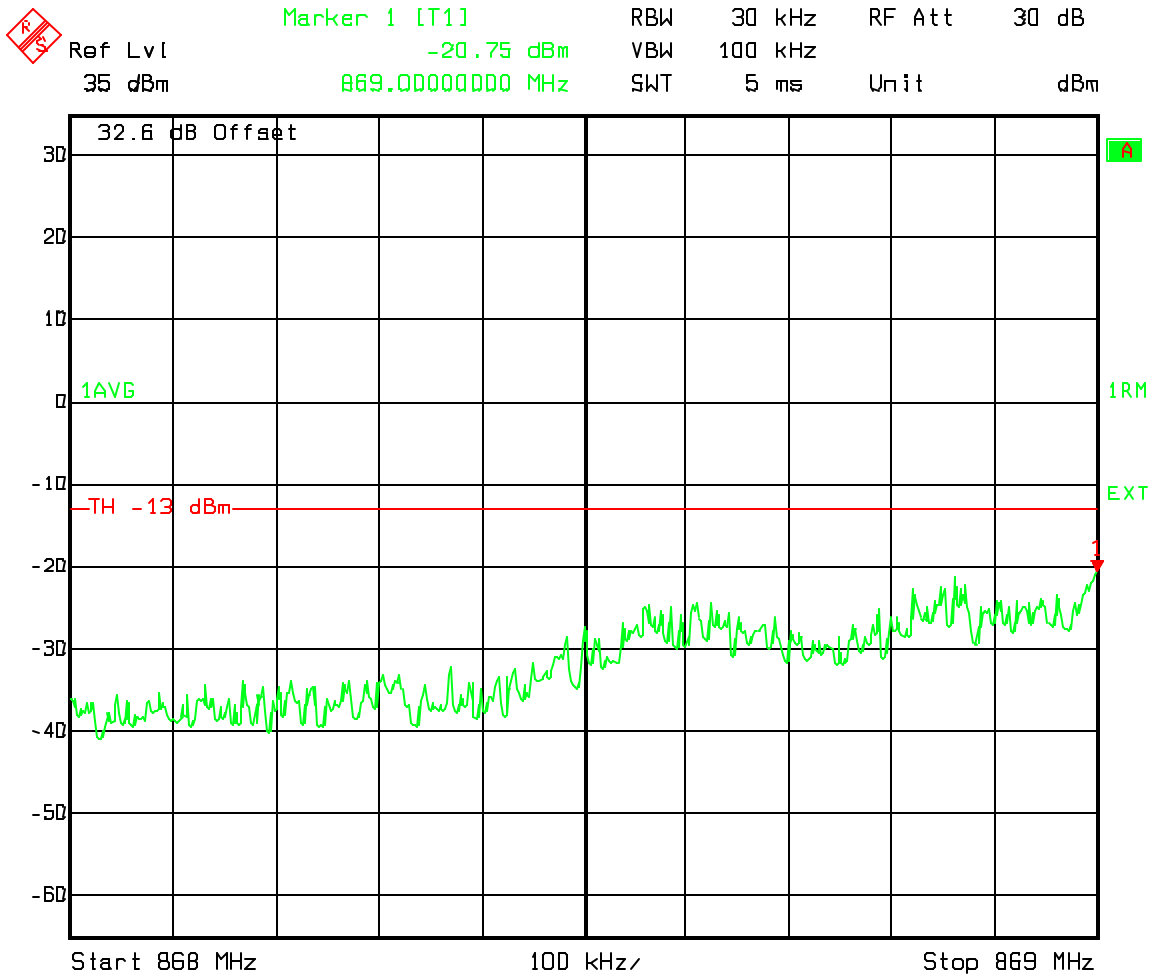

Date: 12.JAN.2004 18:03:58

**Single Chan 1015 IS95 Spurious Emissions at the 800 MHz MFRM2 Ant. Port one
Carrier band A and A'' IS95**

A'' Band Ch1015 IS95 Adjacent 30kHz Lower emissions to 869 MHz

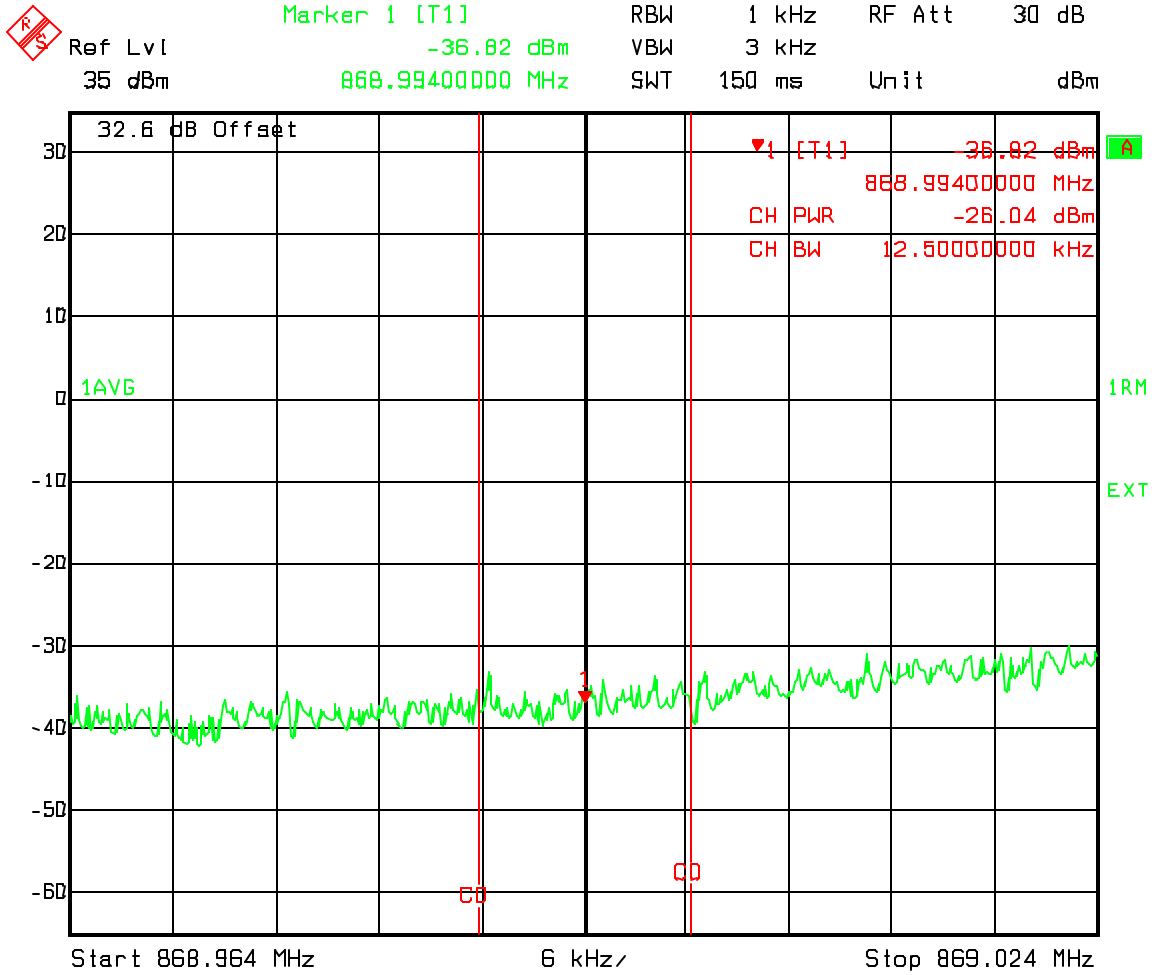

Date: 12.JAN.2004 18:04:40

Single Chan 1015 IS95 Spurious Emissions at the 800 MHz MFRM2 Ant. Port one Carrier band A and A'' IS95

Ch 308 Upper A Band adjacent 1MHz band emissions

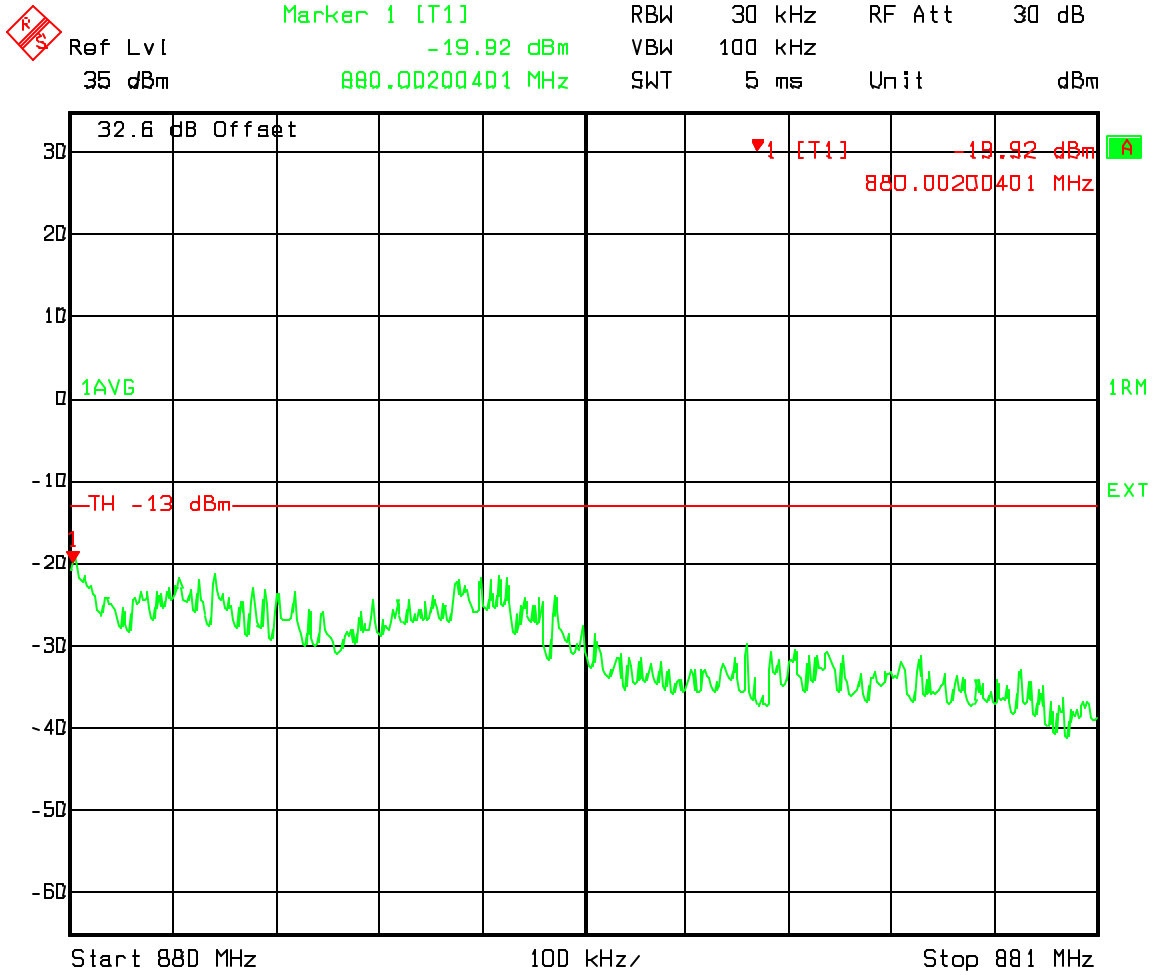

Date: 12.JAN.2004 19:01:58

**Single Chan 1015 IS95 Spurious Emissions at the 800 MHz MFRM2 Ant. Port one
Carrier band A and A'' IS95**

Ch 308 Upper A Band adjacent to outside edge 12.5 kHz band Channel power

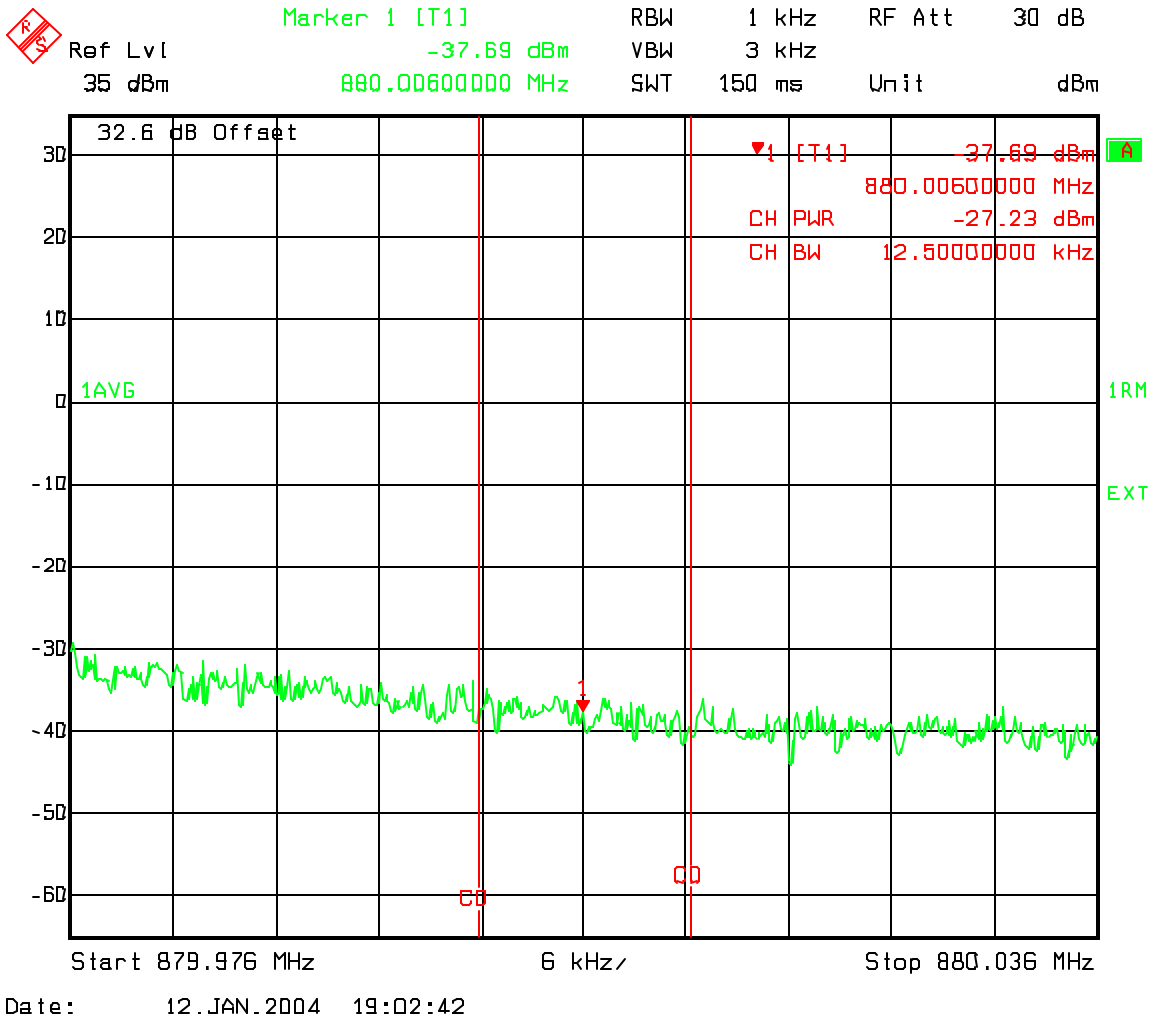

**Single Chan 1015 IS95 Spurious Emissions at the 800 MHz MFRM2 Ant. Port one
Carrier band A and A'' IS95**

Industry Canada Lower 750 kHz offset 30kHz Chan Power Ch 1015

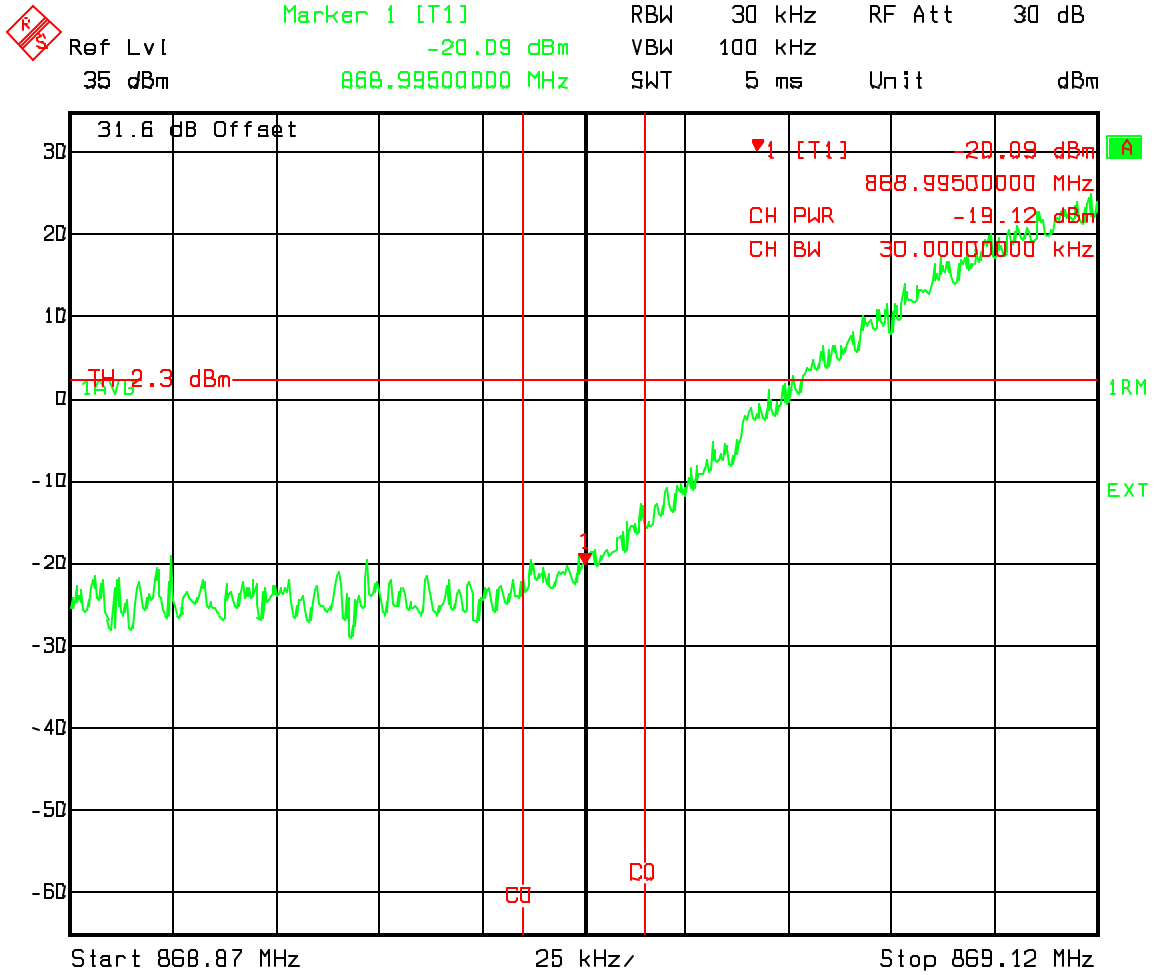

Date: 14.JAN.2004 22:42:13

**Single Chan 1015 IS95 Spurious Emissions at the 800 MHz MFRM2 Ant. Port one
Carrier band A and A'' IS95**

Industry Canada Upper 750 kHz offset 30kHz Chan Power Ch 1015

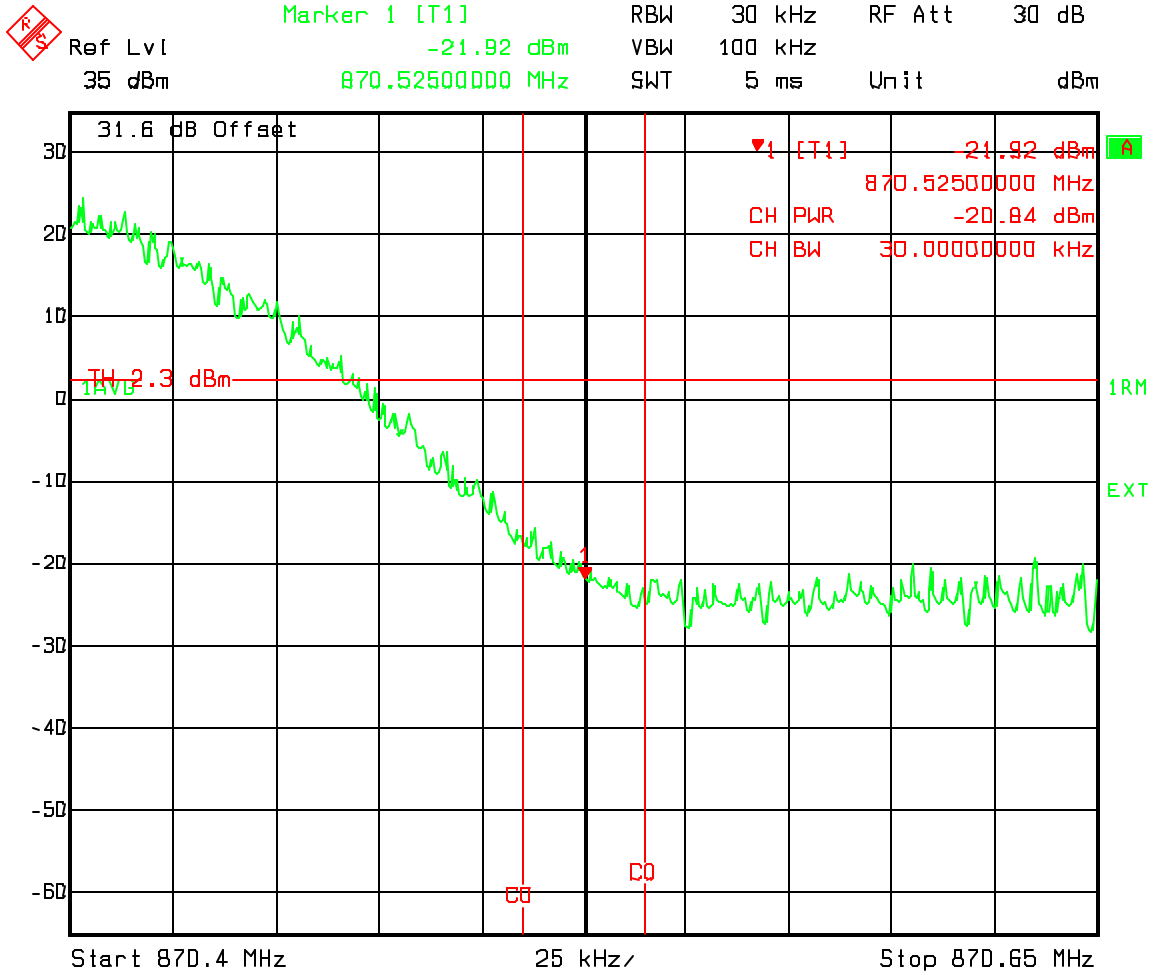

Date: 14.JAN.2004 22:43:00

**Single Chan 1015 IS95 Spurious Emissions at the 800 MHz MFRM2 Ant. Port one
Carrier band A and A'' IS95**

Industry Canada 1.98 MHz offset Lower 30kHz Chan Power Ch 1015

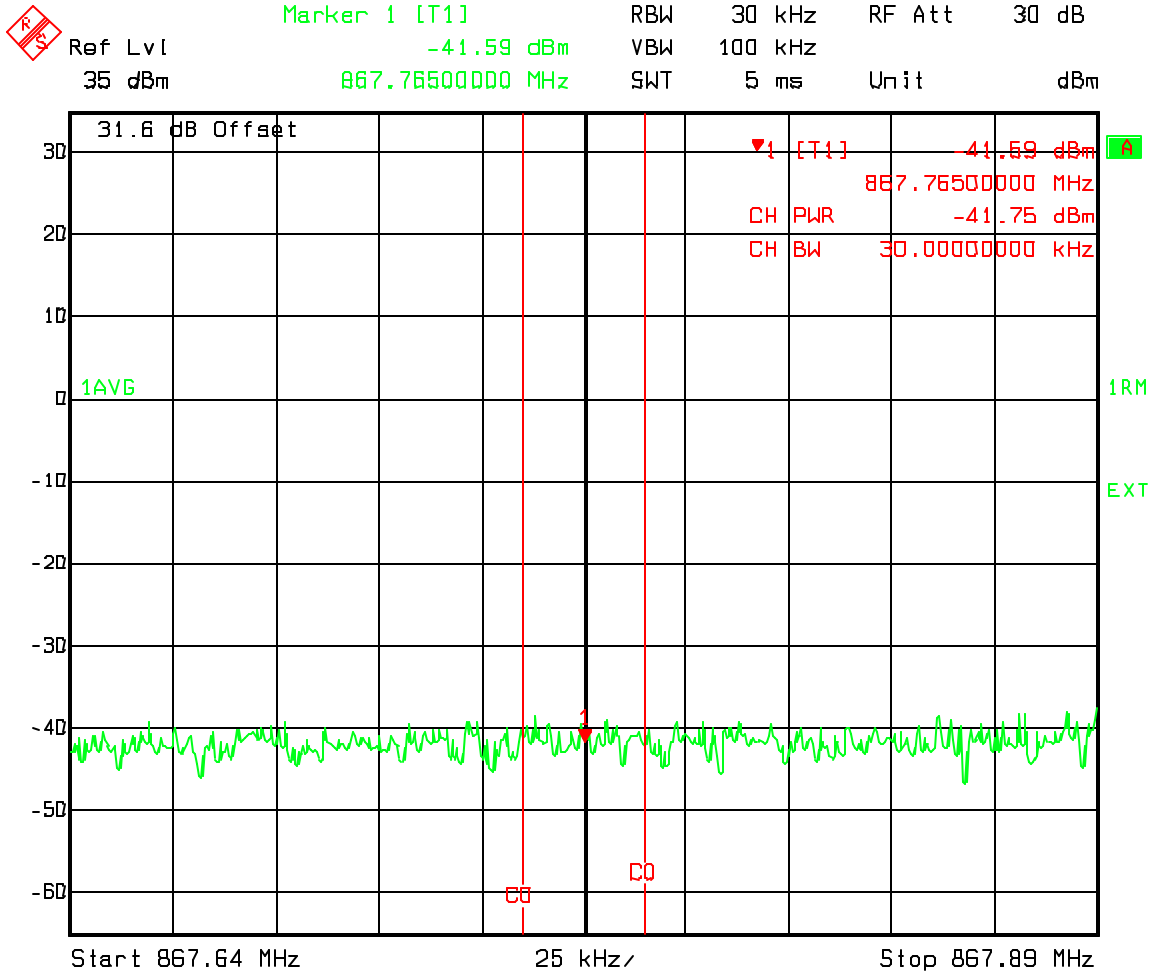

Date: 14.JAN.2004 22:43:44

**Single Chan 1015 IS95 Spurious Emissions at the 800 MHz MFRM2 Ant. Port one
Carrier band A and A'' IS95**

Industry Canada 1.98 MHz offset Upper 30kHz Chan Power Ch 1015

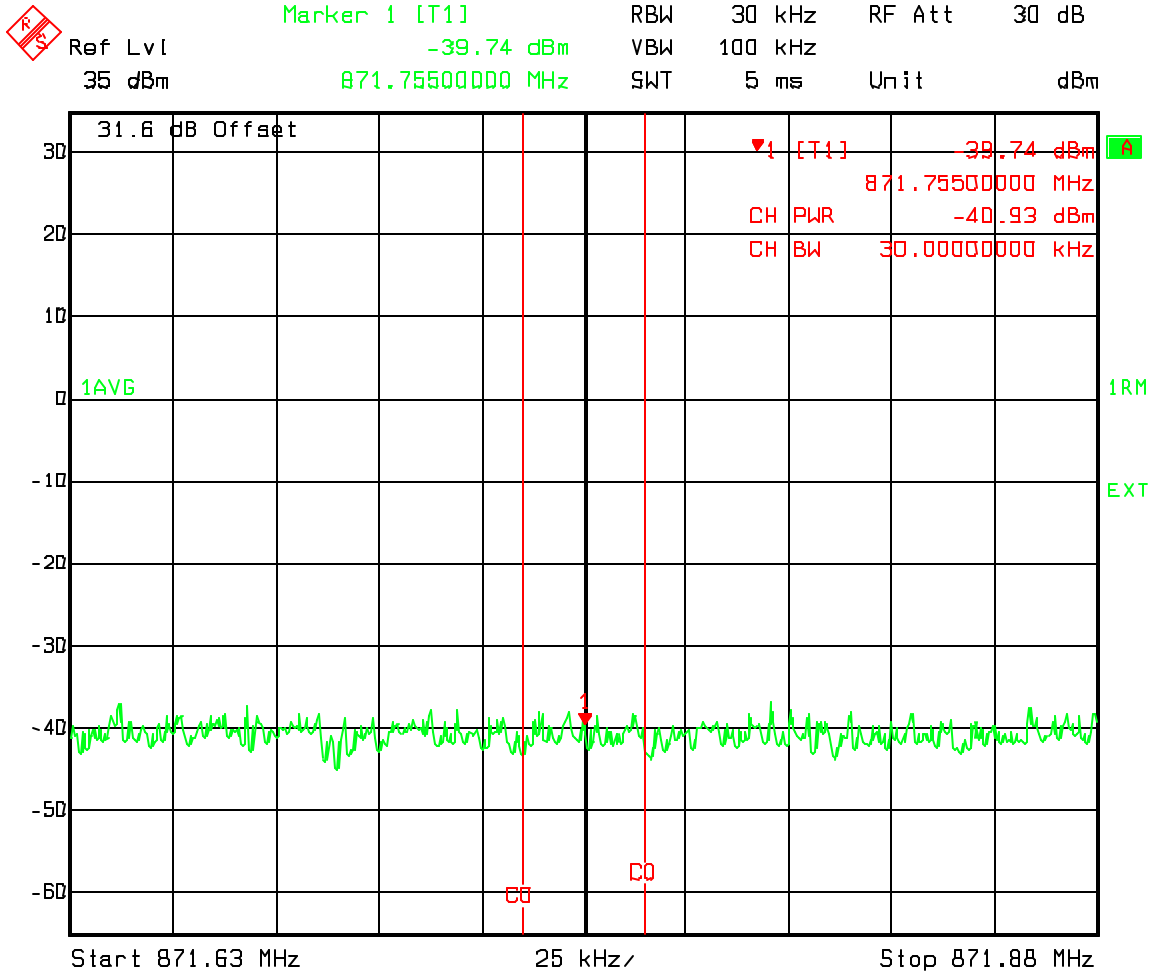

Date: 14.JAN.2004 22:44:29

**Single Chan 1015 IS95 Spurious Emissions at the 800 MHz MFRM2 Ant. Port one
Carrier band A and A'' IS95**

A'' and A Band IS95 Spurious emissions 10kHz-400 MHz

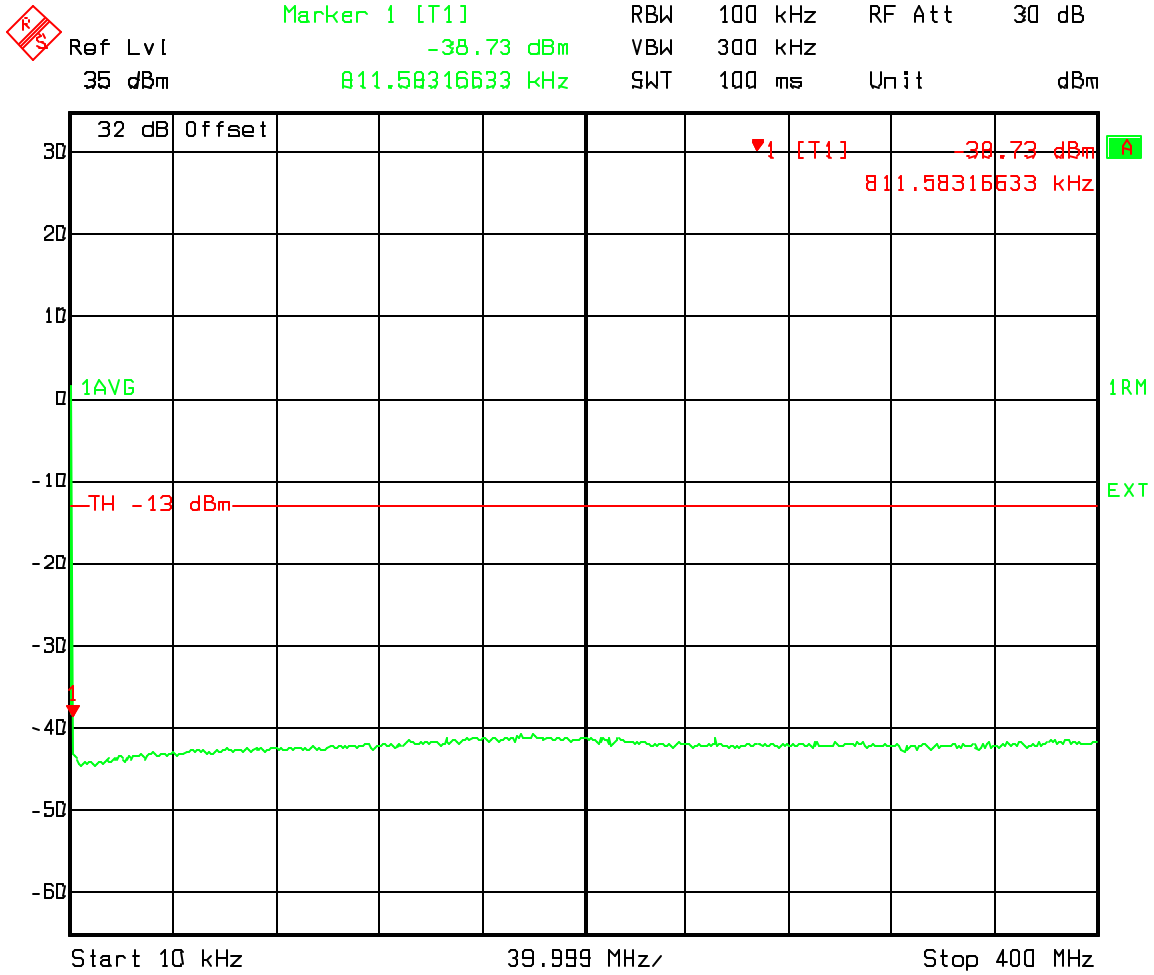

Date: 12.JAN.2004 18:06:57

**Single Chan 1015 IS95 Spurious Emissions at the 800 MHz MFRM2 Ant. Port one
Carrier band A and A'' IS95**

A'' and A Band IS95 Spurious emissions 400MHz to Lower 1MHz Band Edge

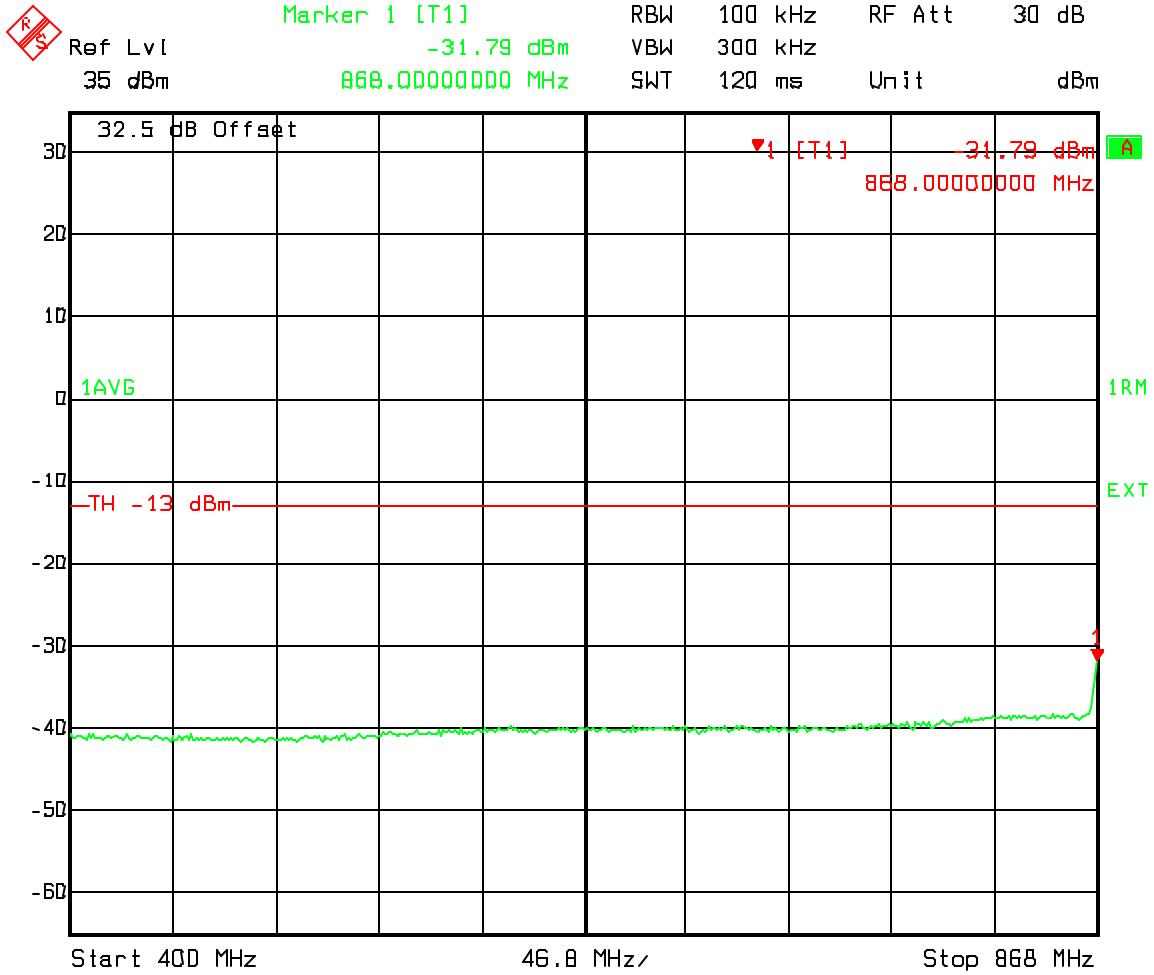

Date: 12.JAN.2004 18:23:30

**Single Chan 1015 IS95 Spurious Emissions at the 800 MHz MFRM2 Ant. Port one
Carrier band A and A'' IS95**

A'' and A Band IS95 Spurious emissions Upper 1MHz Band Edge to 1GHz

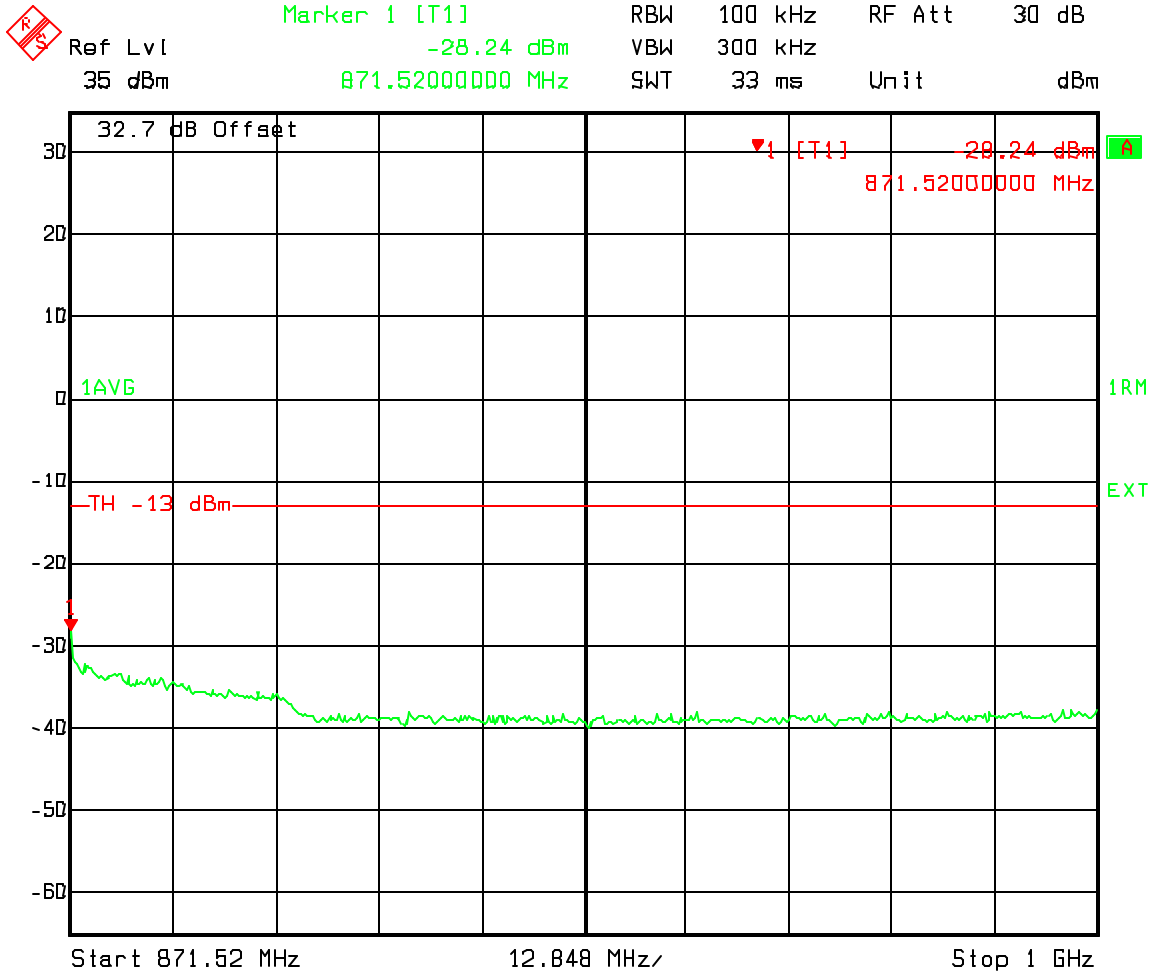

Date: 12.JAN.2004 18:24:13

**Single Chan 1015 IS95 Spurious Emissions at the 800 MHz MFRM2 Ant. Port one
Carrier band A and A'' IS95**

A'' and A Band IS95 Spurious emissions 400-1000 MHz

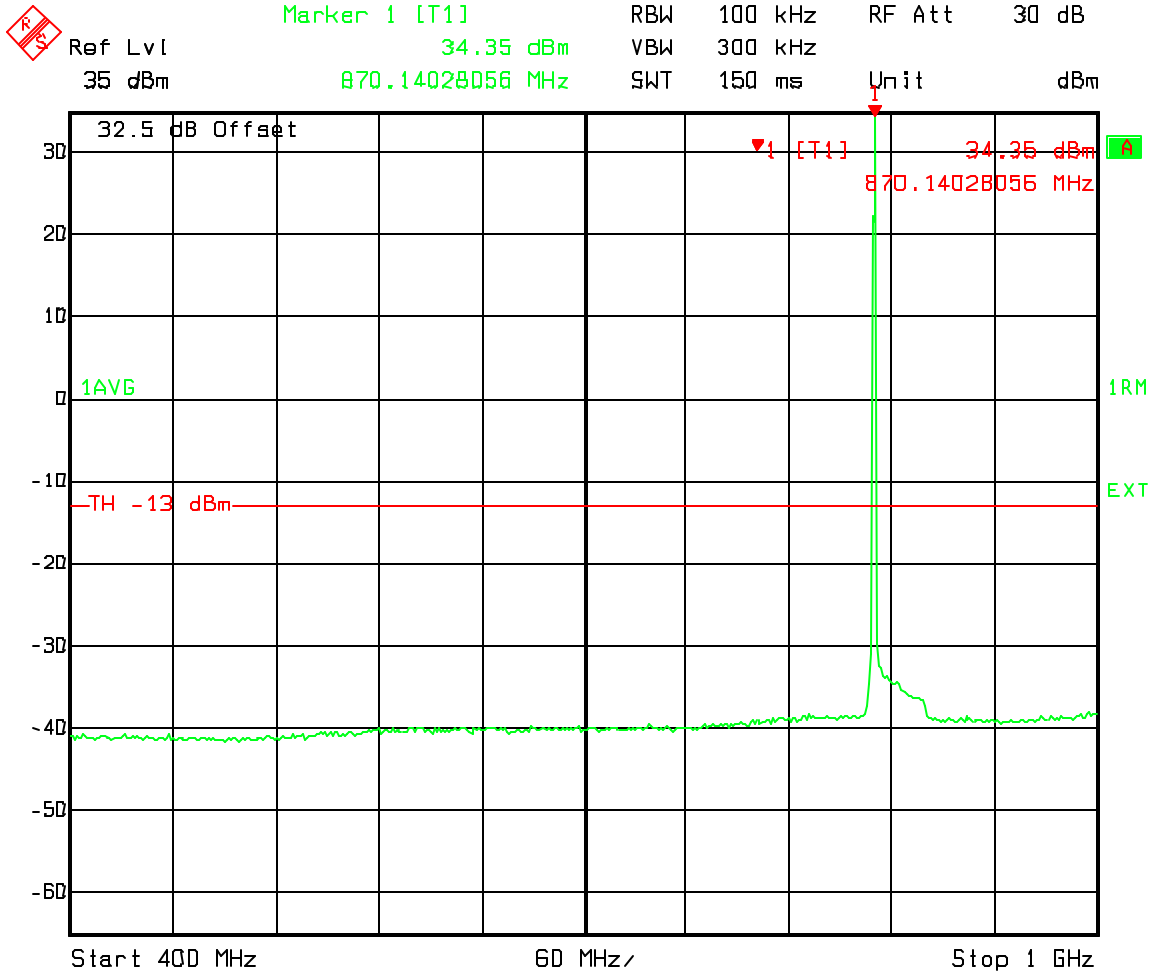

Date: 12.JAN.2004 18:07:41

**Single Chan 1015 IS95 Spurious Emissions at the 800 MHz MFRM2 Ant. Port one
Carrier band A and A'' IS95**

A'' and A Band IS95 Spurious emissions 1000-2000 MHz

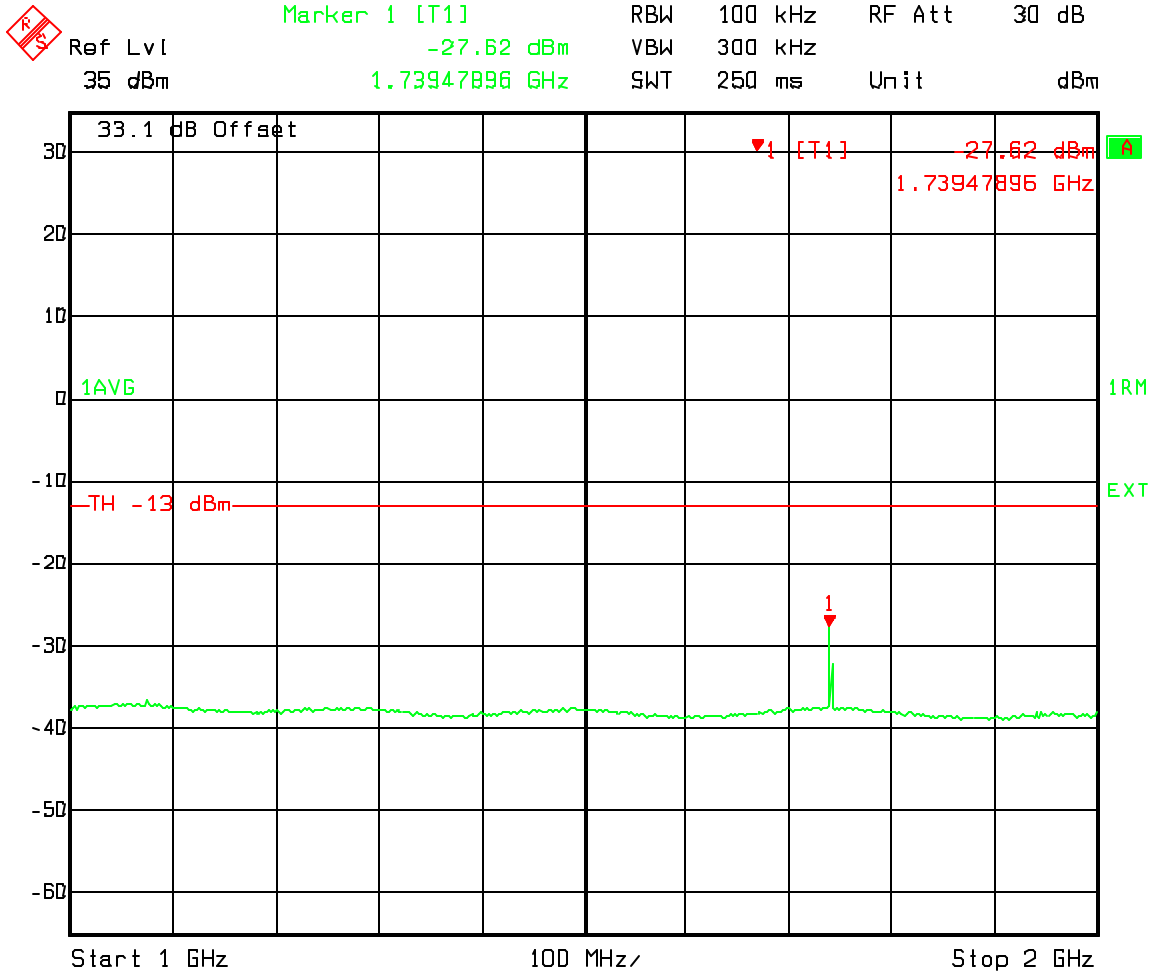

Date: 12.JAN.2004 18:08:24

**Single Chan 1015 IS95 Spurious Emissions at the 800 MHz MFRM2 Ant. Port one
Carrier band A and A'' IS95**

A'' and A Band IS95 Spurious emissions 2000-3000 MHz

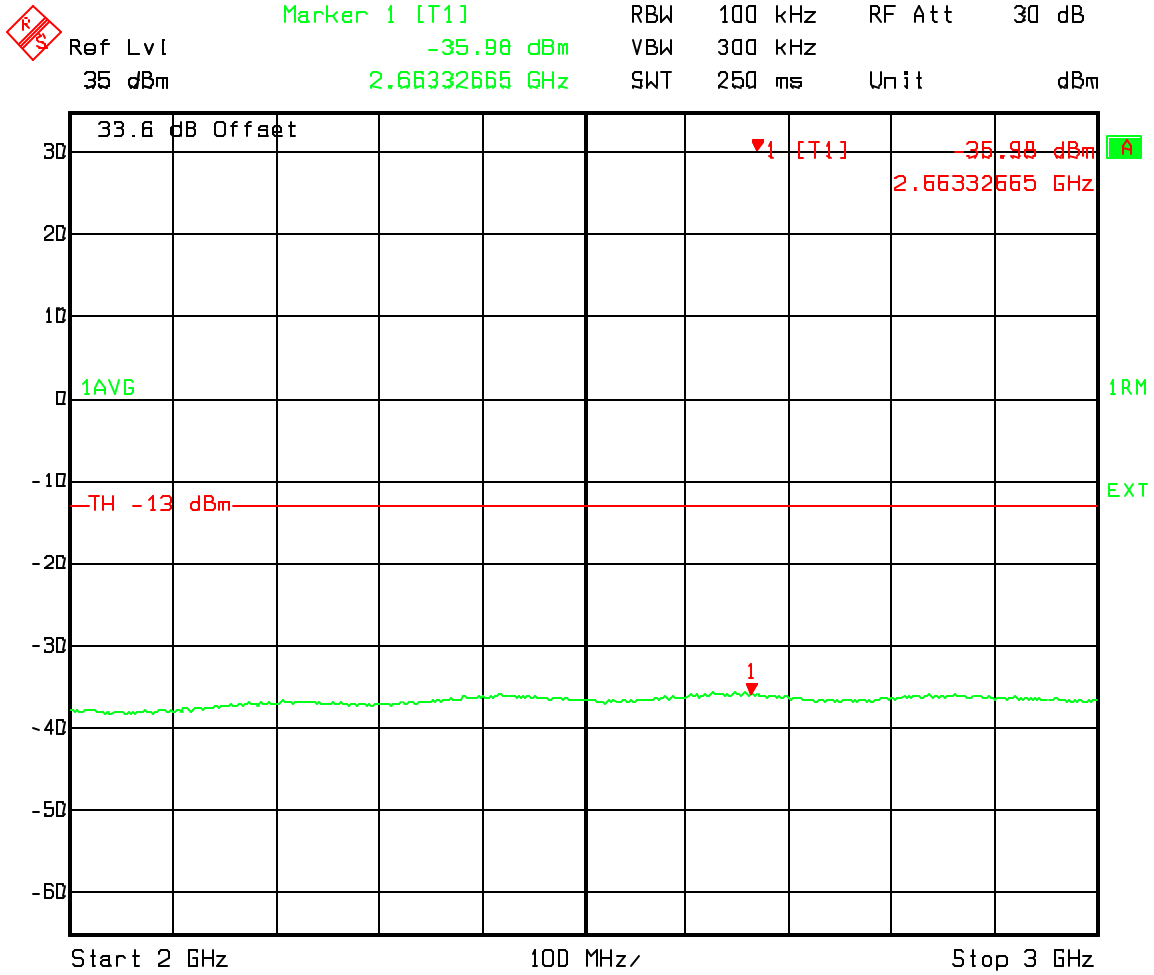

Date: 12.JAN.2004 18:09:09

**Single Chan 1015 IS95 Spurious Emissions at the 800 MHz MFRM2 Ant. Port one
Carrier band A and A'' IS95**

A'' and A Band IS95 Spurious emissions 3000-4000 MHz

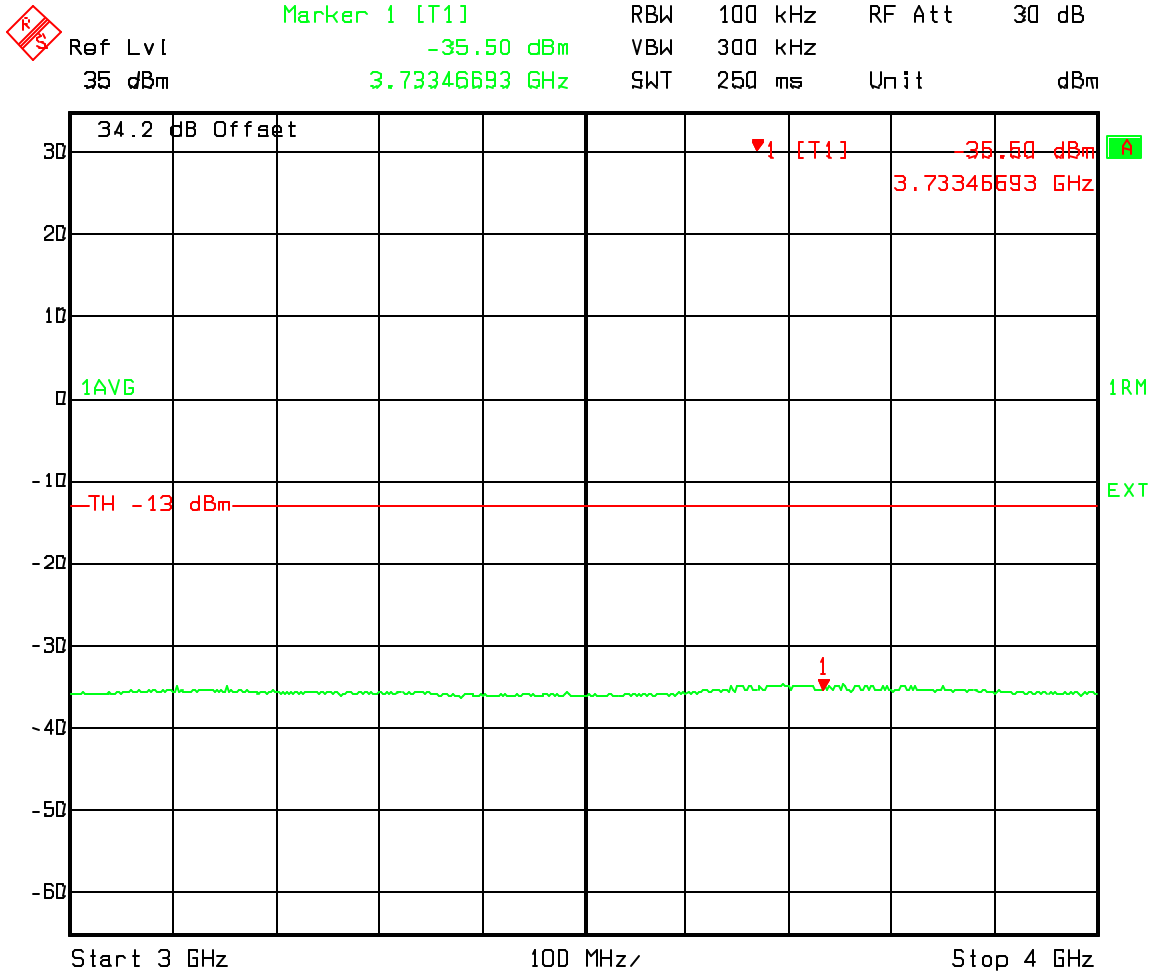

Date: 12.JAN.2004 18:09:52

**Single Chan 1015 IS95 Spurious Emissions at the 800 MHz MFRM2 Ant. Port one
Carrier band A and A'' IS95**

A'' and A Band IS95 Spurious emissions 4000-5000 MHz

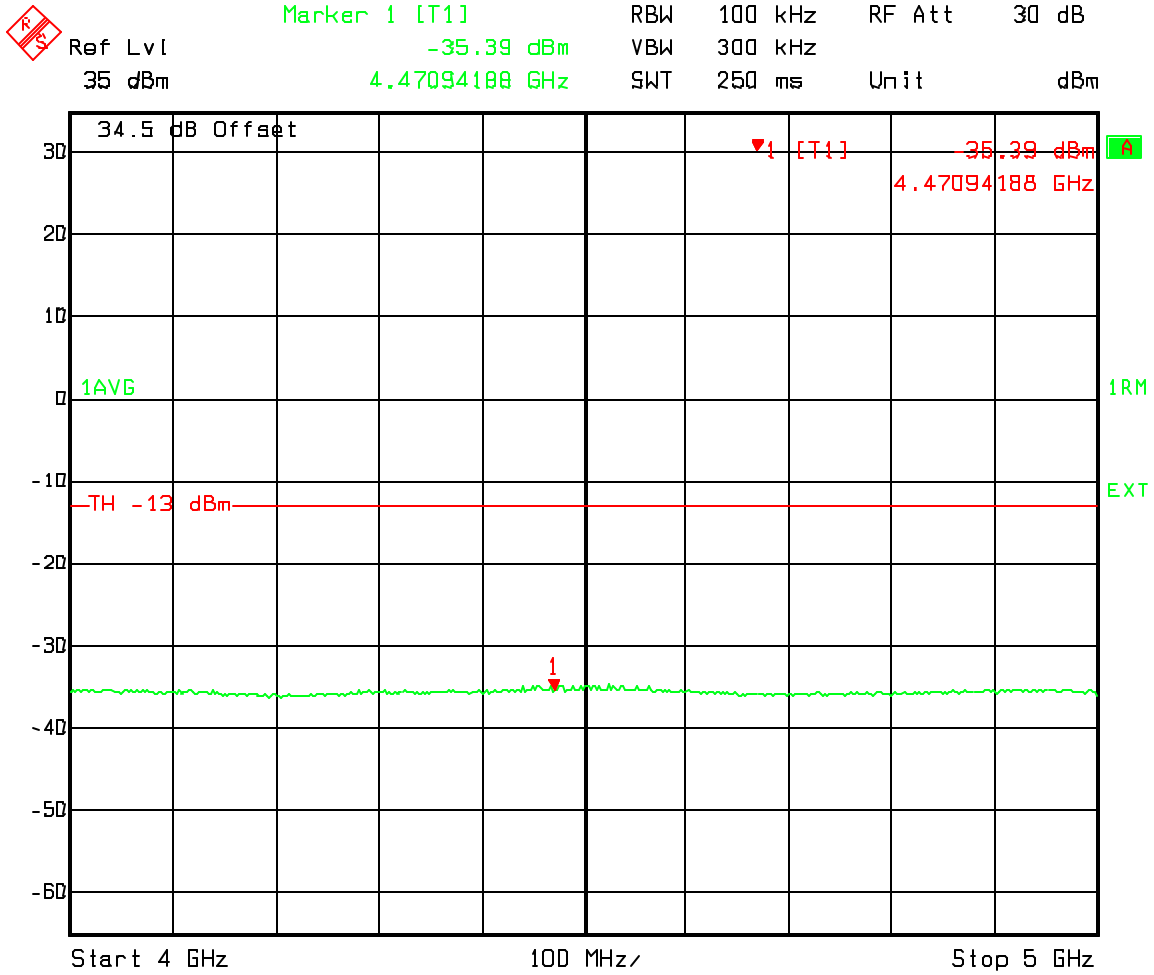

Date: 12.JAN.2004 18:10:37

**Single Chan 1015 IS95 Spurious Emissions at the 800 MHz MFRM2 Ant. Port one
Carrier band A and A'' IS95**

A'' and A Band IS95 Spurious emissions 5000-6000 MHz

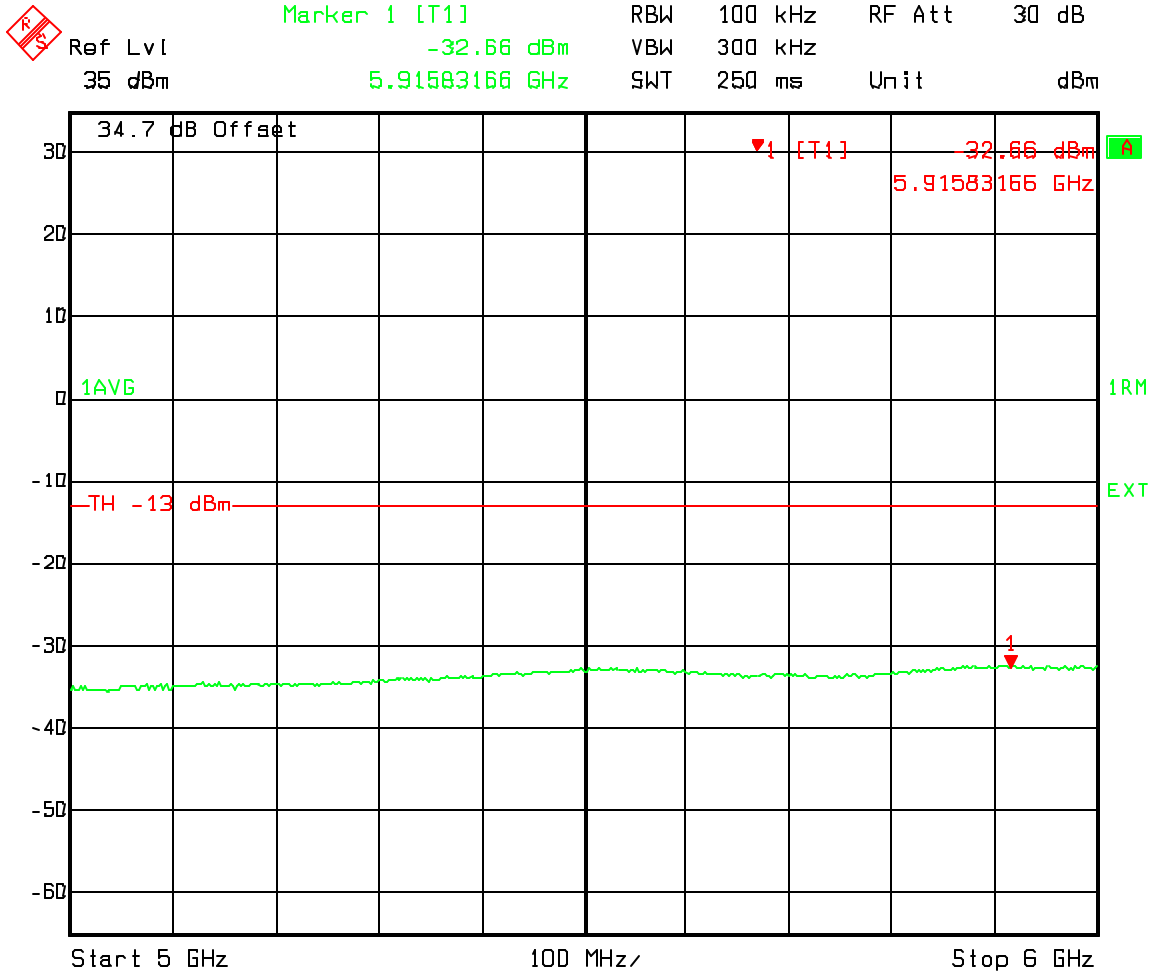

Date: 12.JAN.2004 18:11:22

**Single Chan 1015 IS95 Spurious Emissions at the 800 MHz MFRM2 Ant. Port one
Carrier band A and A'' IS95**

A'' and A Band IS95 Spurious emissions 6000-7000 MHz

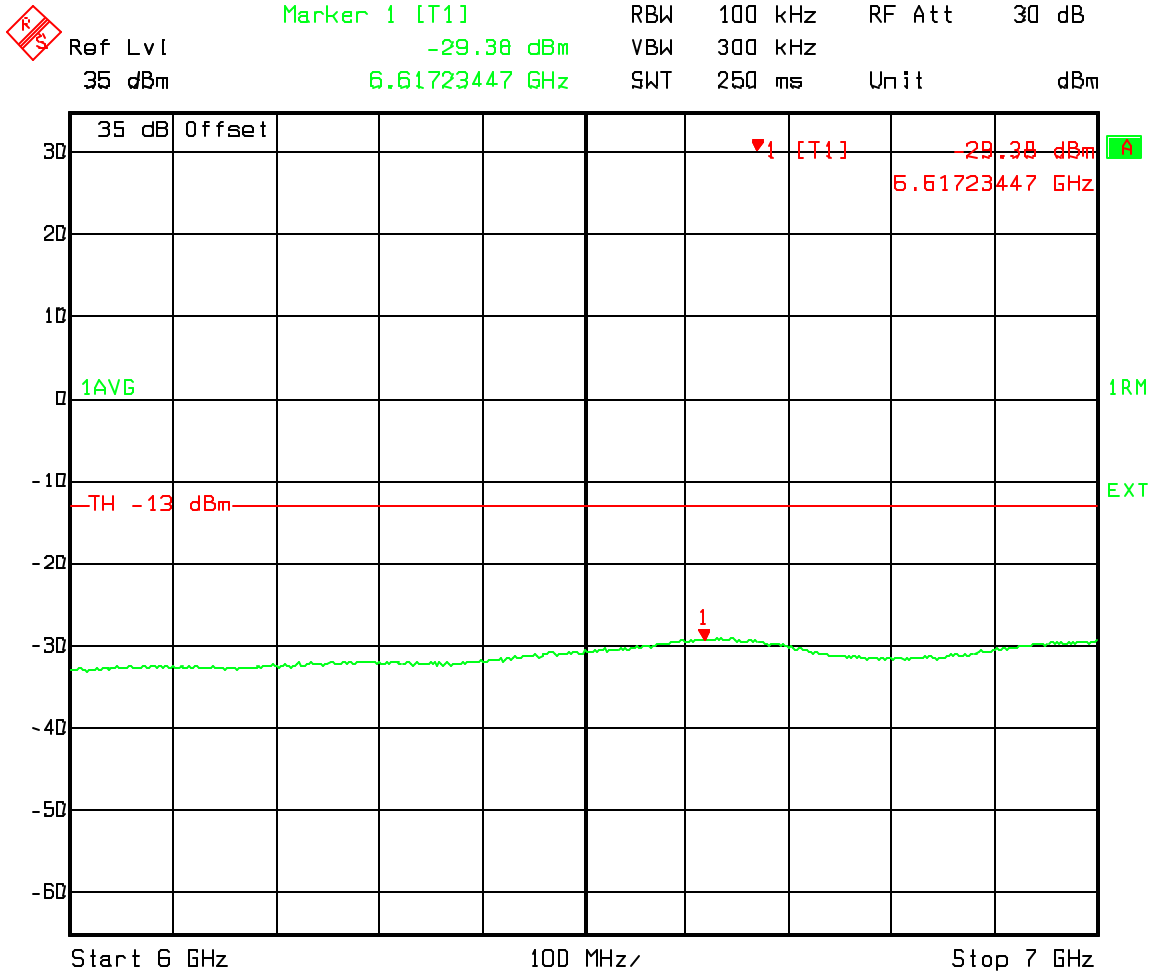

Date: 12.JAN.2004 18:12:07

**Single Chan 1015 IS95 Spurious Emissions at the 800 MHz MFRM2 Ant. Port one
Carrier band A and A'' IS95**

A'' and A Band IS95 Spurious emissions 7000-8000 MHz

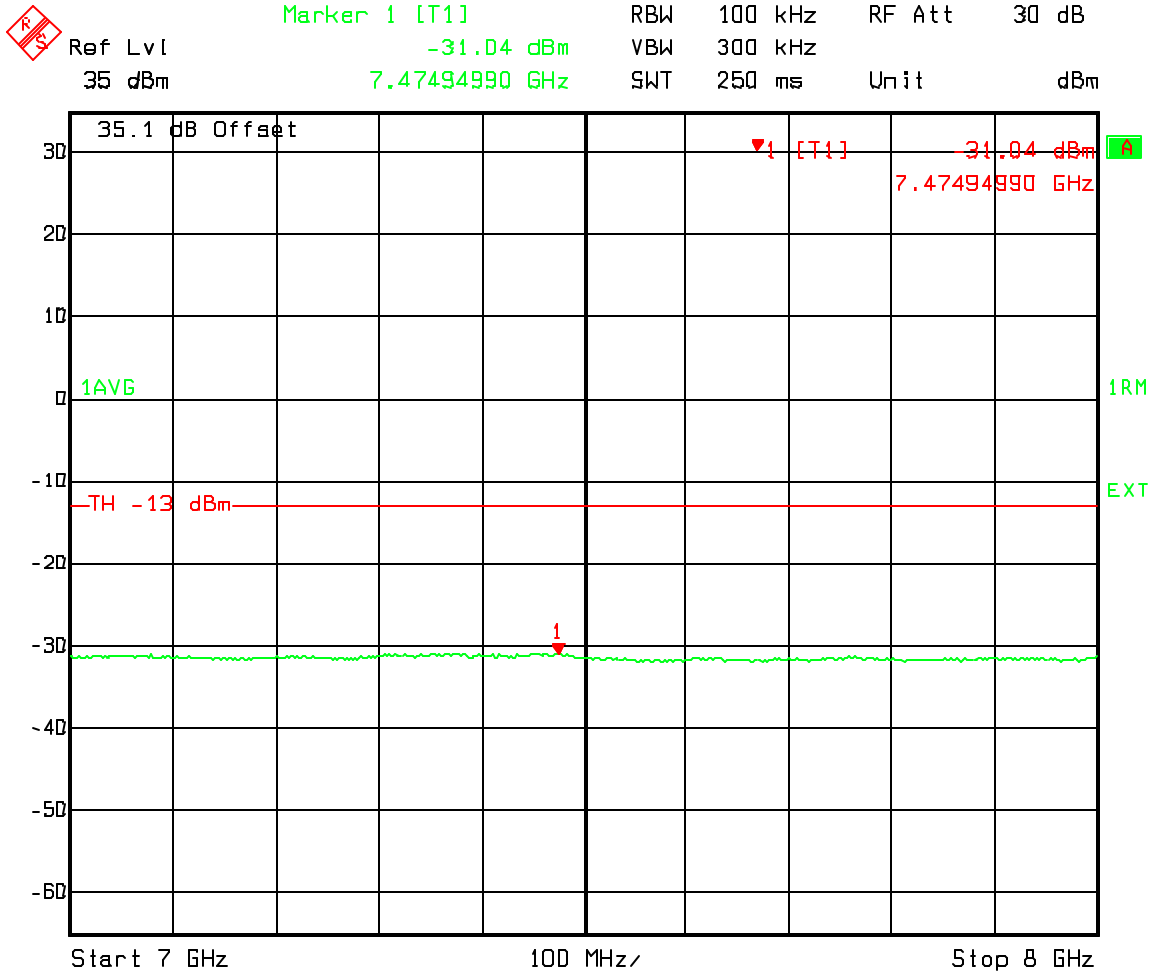

Date: 12.JAN.2004 18:12:53

**Single Chan 1015 IS95 Spurious Emissions at the 800 MHz MFRM2 Ant. Port one
Carrier band A and A'' IS95**

A'' and A Band IS95 Spurious emissions 8000-9000 MHz

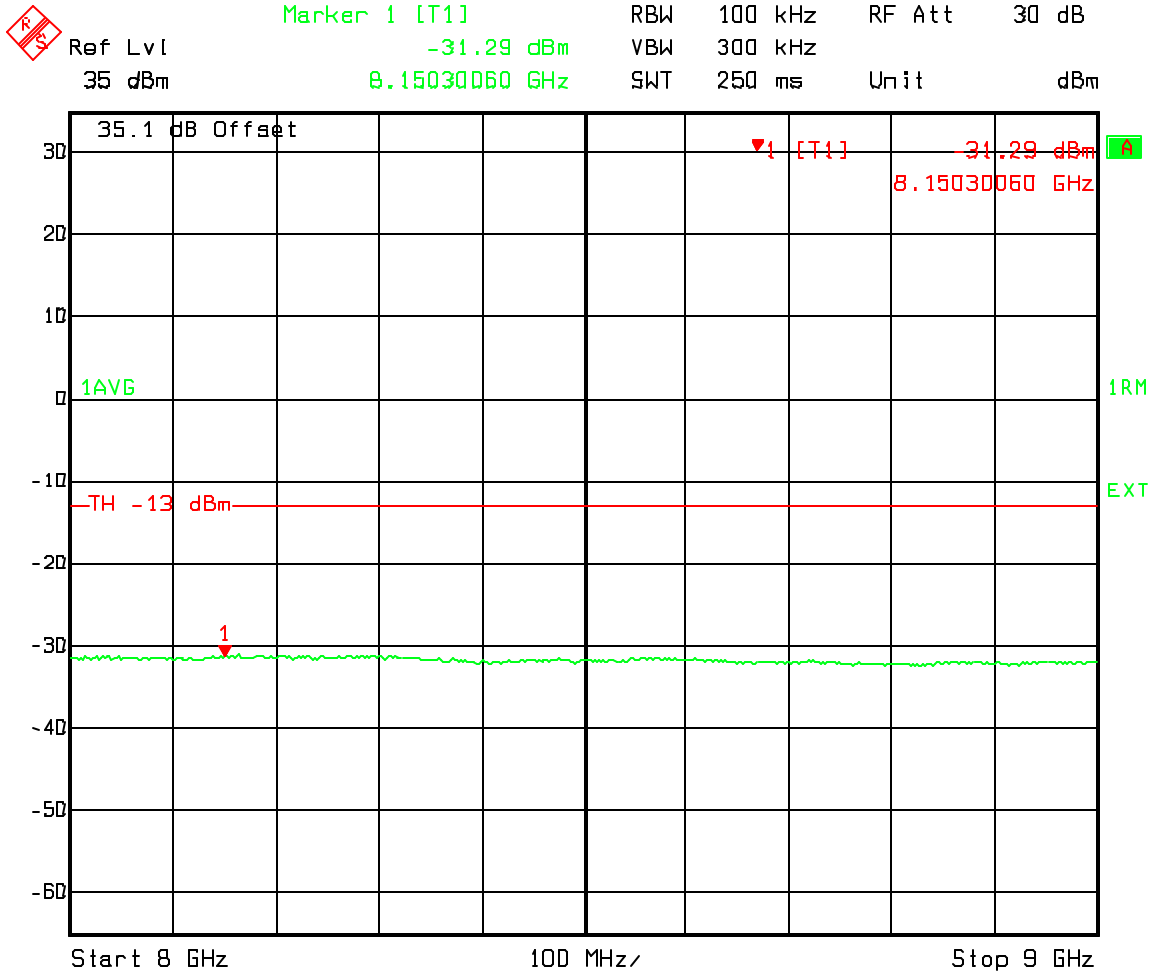

Date: 12.JAN.2004 18:13:39

**Single Chan 1015 IS95 Spurious Emissions at the 800 MHz MFRM2 Ant. Port one
Carrier band A and A'' IS95**

A'' and A Band IS95 Spurious emissions 9000-10000 MHz

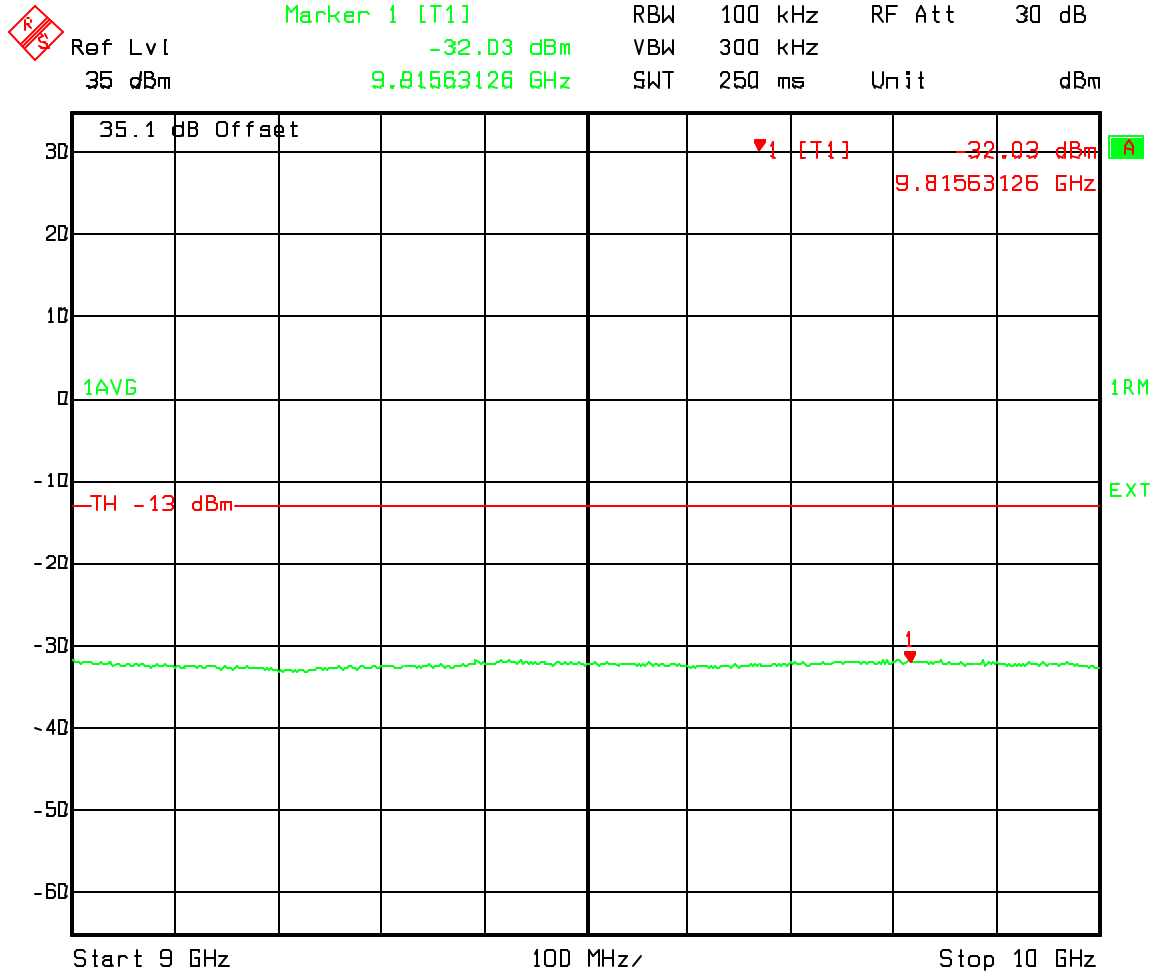

Date: 12.JAN.2004 18:14:24

Two Carrier 1015, 33 and 267, 308 Spurious Emissions at the 800 MHz MFRM2 Ant. Port band A and A'' IS95

Occupied Bandwidth Ch 1015, 33 A''

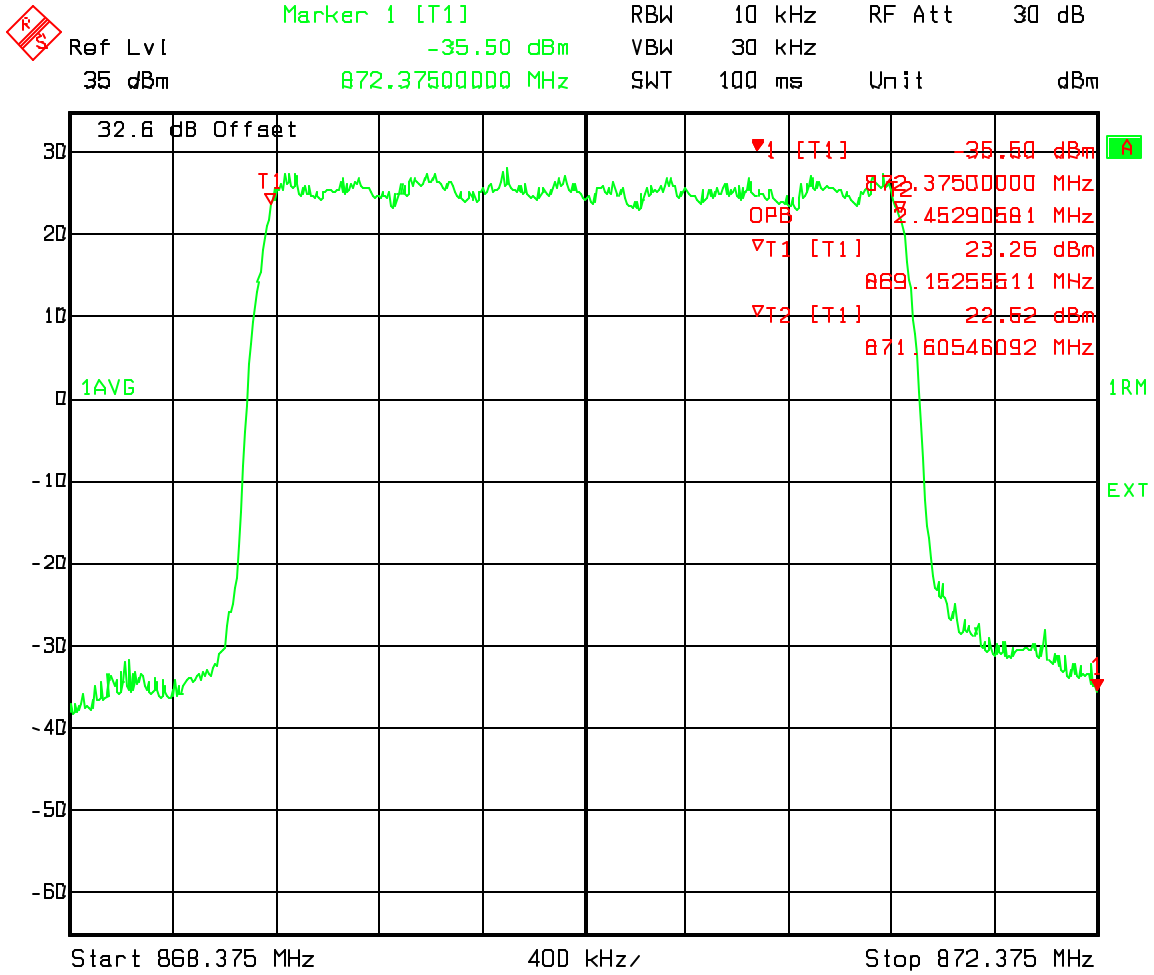

Two Carrier 1015, 33 and 267, 308 Spurious Emissions at the 800 MHz MFRM2 Ant. Port band A and A'' IS95

A'' Band Ch 1015, 33 IS95 Adjacent 1Mhz Lower emissions 868-869MHz

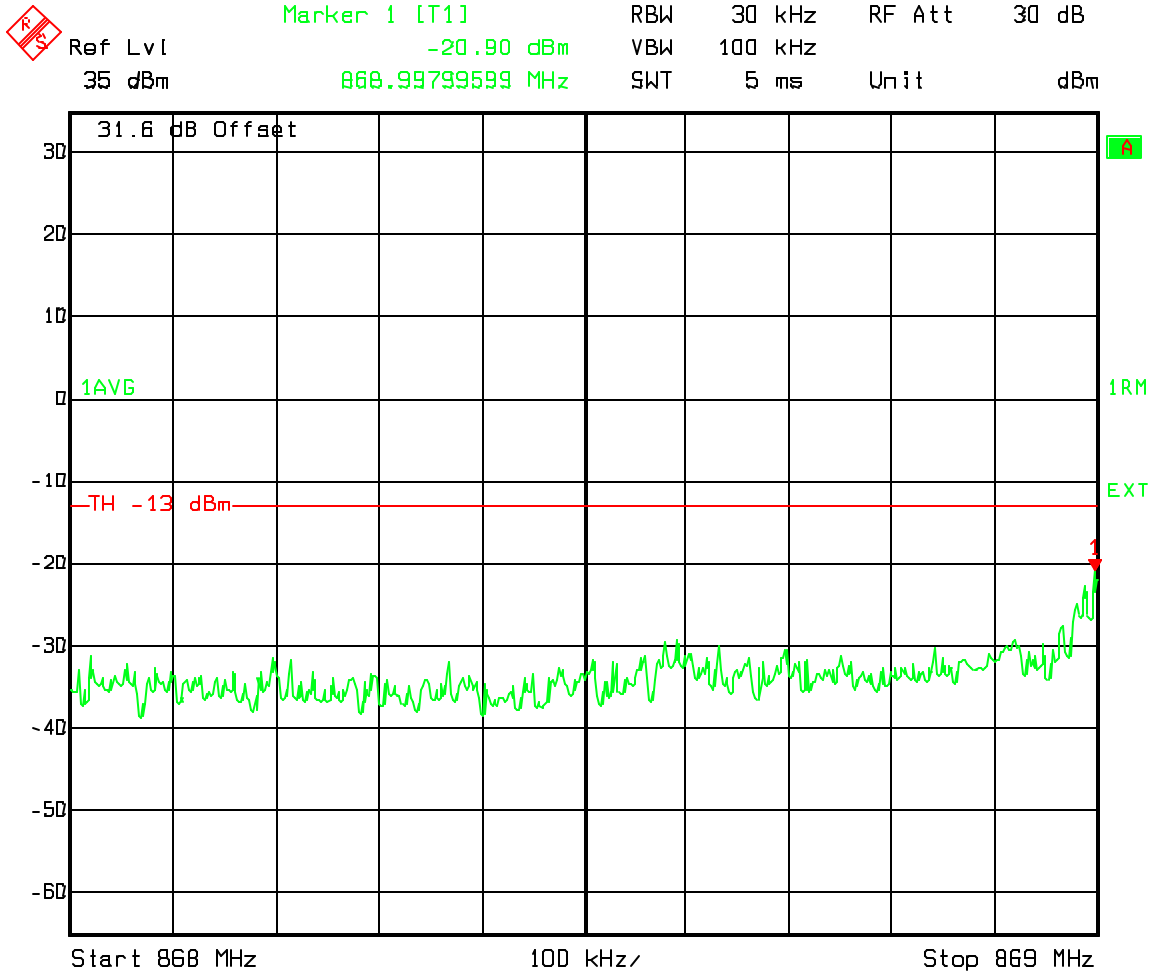

Date: 12.JAN.2004 23:08:07

Two Carrier 1015, 33 and 267, 308 Spurious Emissions at the 800 MHz MFRM2 Ant. Port band A and A'' IS95

A'' Band Ch1015, 33 IS95 Adjacent 30kHz Lower emissions to 869 MHz

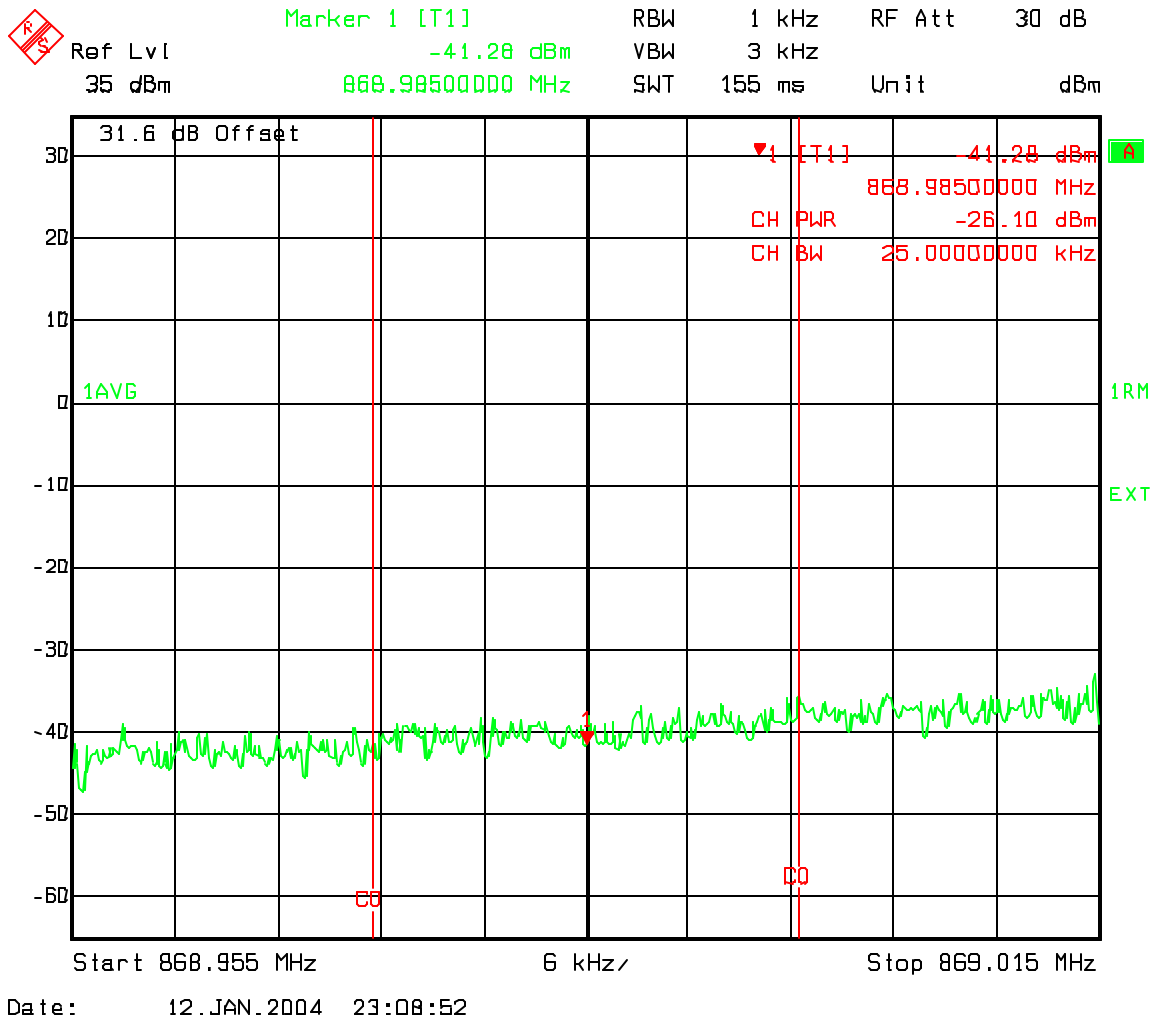

Two Carrier 1015, 33 and 267, 308 Spurious Emissions at the 800 MHz MFRM2 Ant. Port band A and A'' IS95

Ch 267, 308 Upper A Band adjacent 1MHz band emissions 880-881 MHz

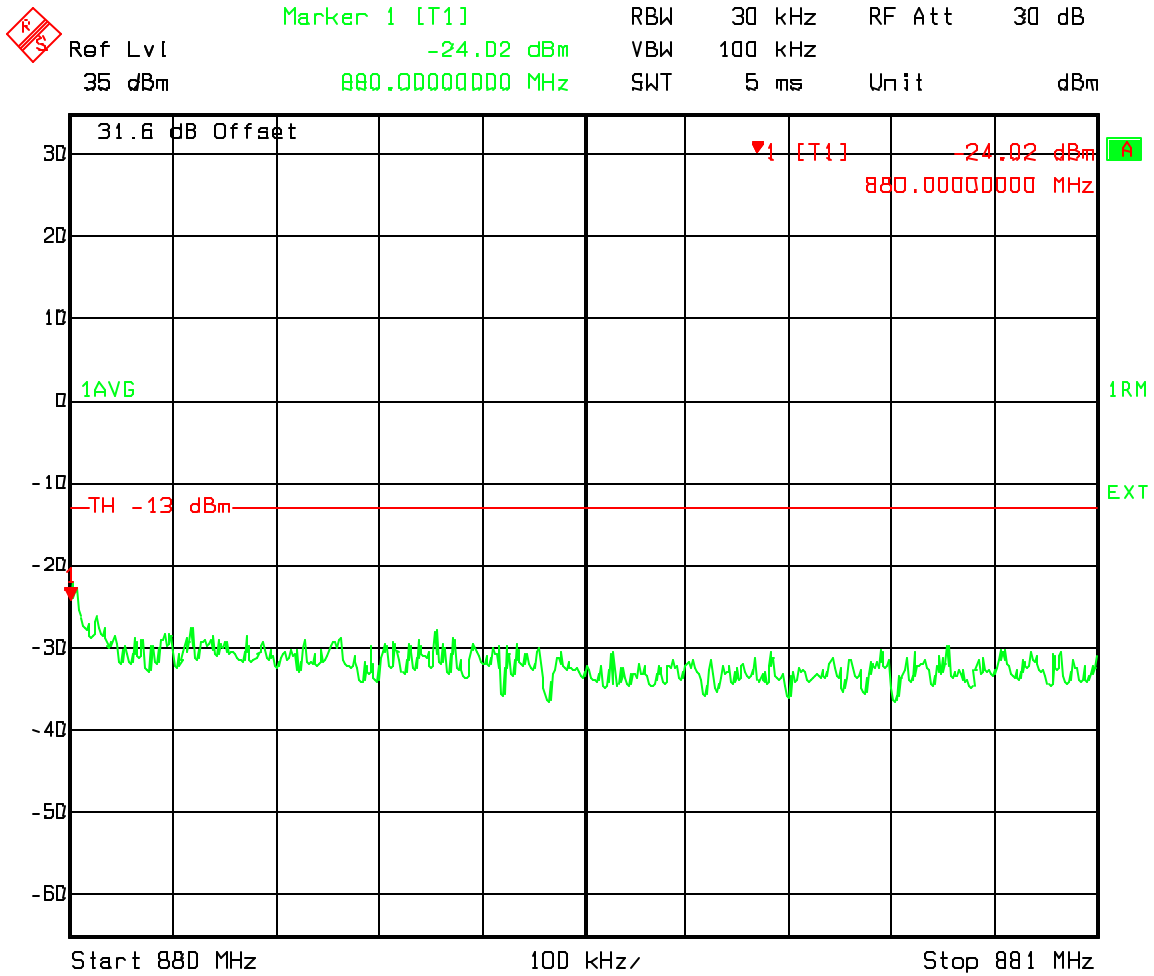

Date: 12.JAN.2004 23:47:55

**Two Carrier 1015, 33 and 267, 308 Spurious Emissions at the 800 MHz MFRM2
 Ant. Port band A and A'' IS95
 Ch 267, 308 Upper A Band adjacent to outside edge 12.5 kHz band Channel power**

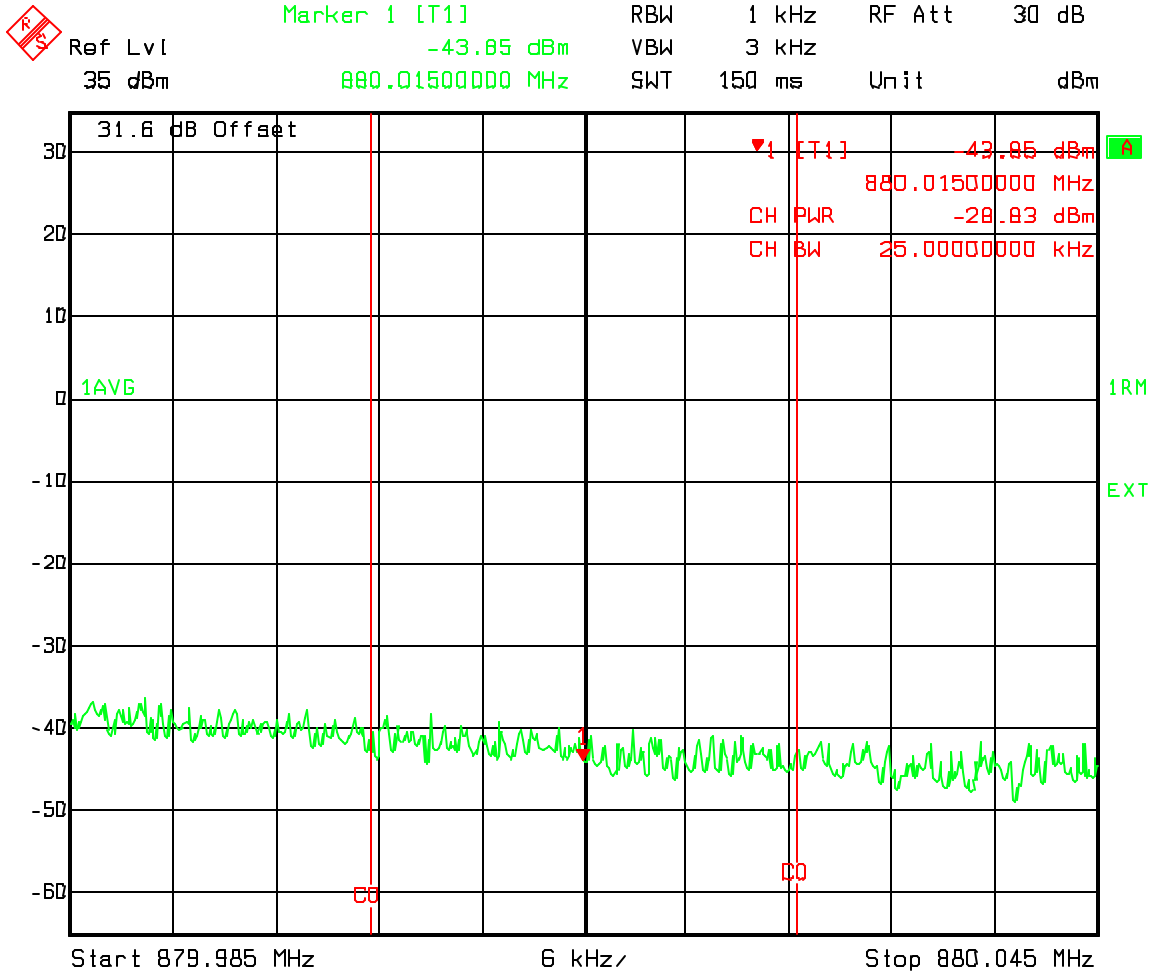

Date: 12.JAN.2004 23:48:46

Two Carrier 1015, 33 and 267, 308 Spurious Emissions at the 800 MHz MFRM2 Ant. Port band A and A'' IS95

Industry Canada Lower 750 kHz offset 30kHz Chan Power Ch 1015, 33

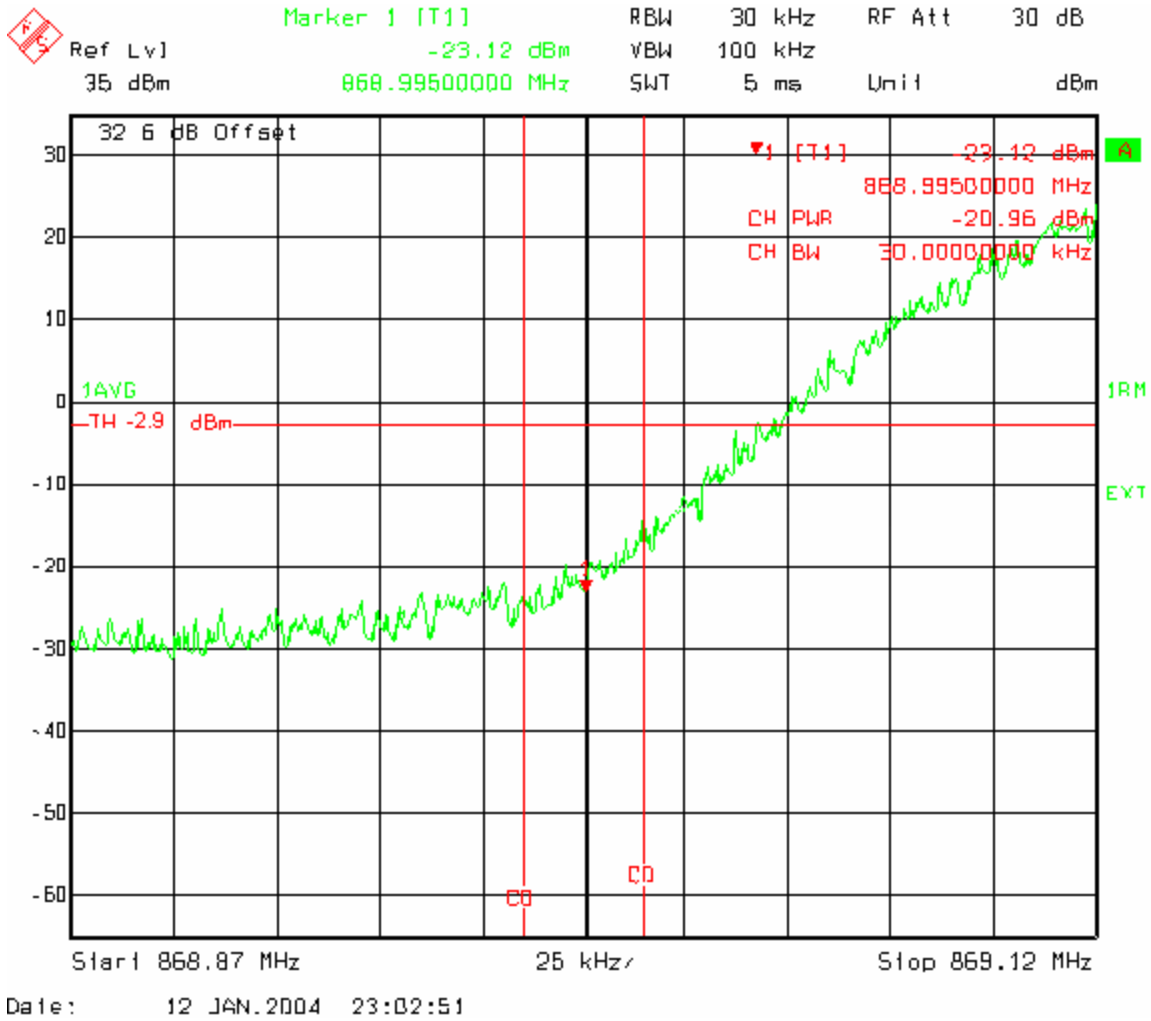

Two Carrier 1015, 33 and 267, 308 Spurious Emissions at the 800 MHz MFRM2 Ant. Port band A and A'' IS95

Industry Canada Upper 750 kHz offset 30kHz Chan Power Ch 1015, 33

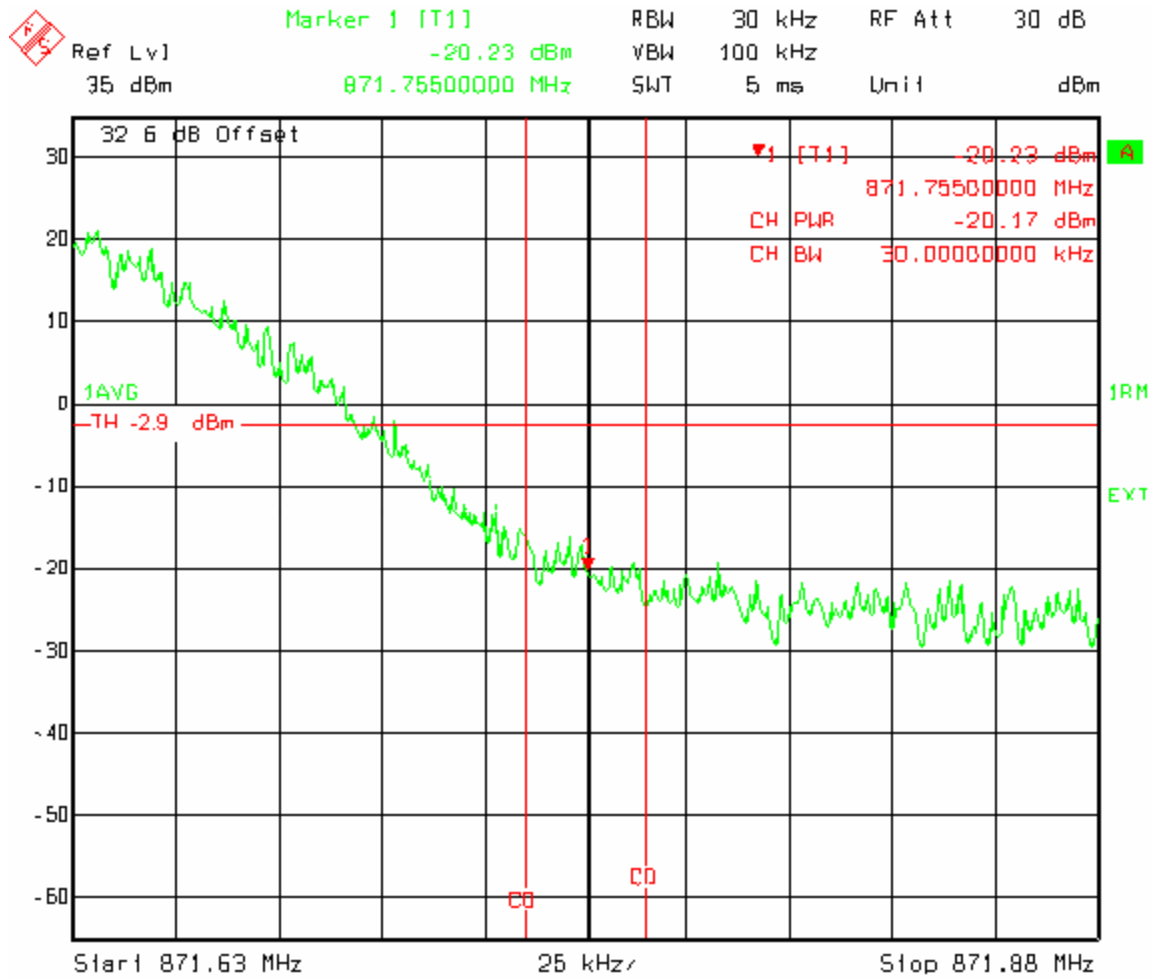

Date: 12 JAN. 2004 23:03:39

Two Carrier 1015, 33 and 267, 308 Spurious Emissions at the 800 MHz MFRM2 Ant. Port band A and A'' IS95

Industry Canada 1.98 MHz offset Lower 30kHz Chan Power Ch 1015, 33

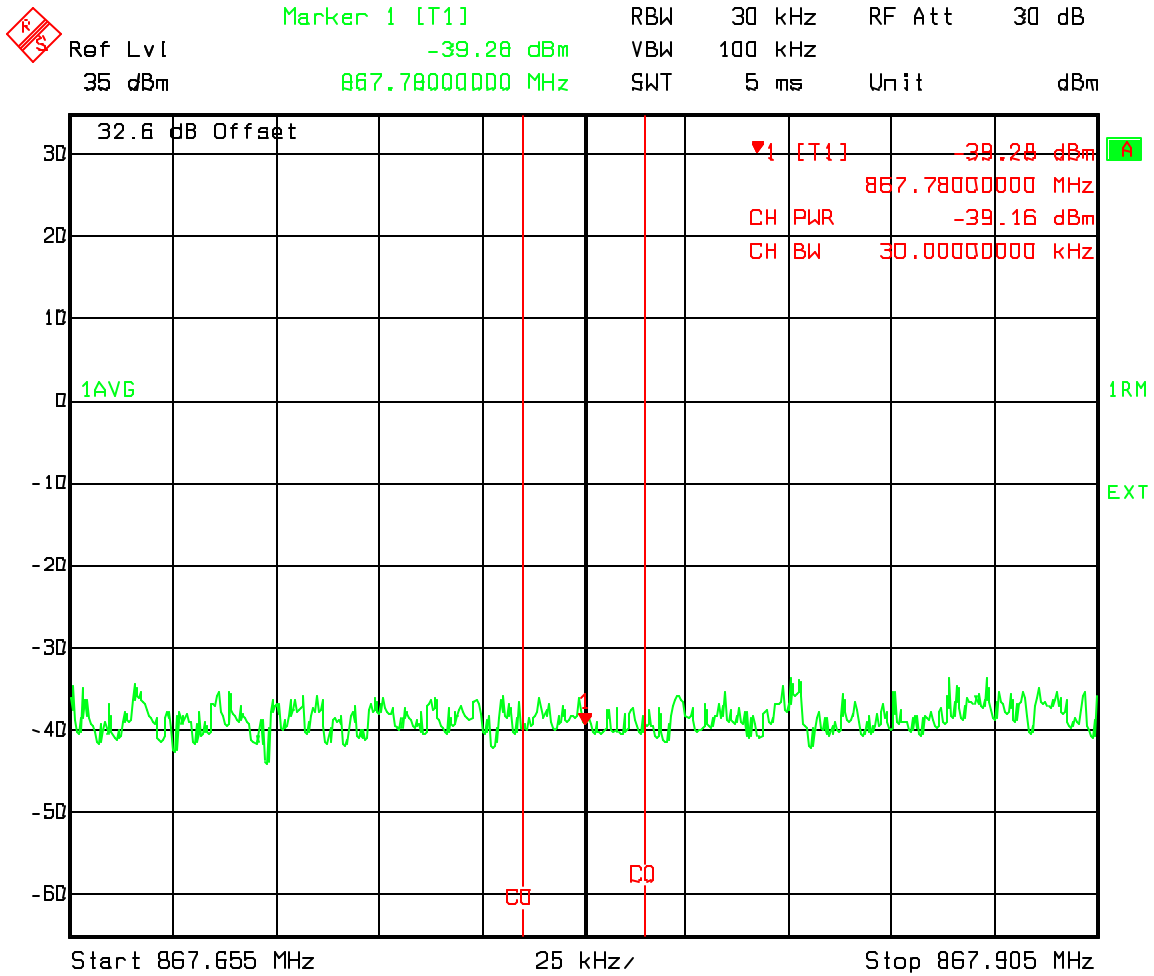

Date: 12.JAN.2004 23:04:24

Two Carrier 1015, 33 and 267, 308 Spurious Emissions at the 800 MHz MFRM2 Ant. Port band A and A'' IS95

Industry Canada 1.98 MHz offset Upper 30kHz Chan Power Ch 1015, 33

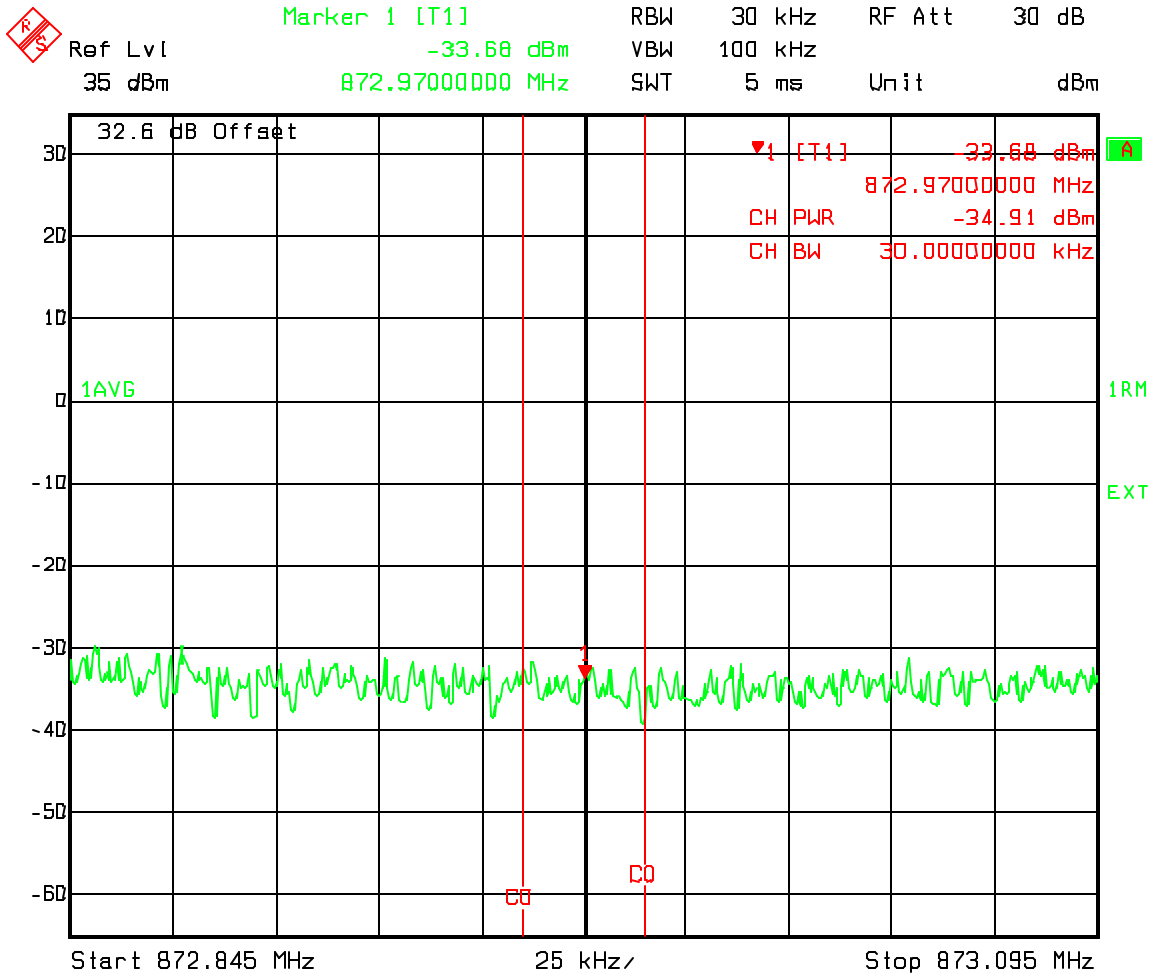

Date: 12.JAN.2004 23:05:10

Two Carrier 1015, 33 and 267, 308 Spurious Emissions at the 800 MHz MFRM2 Ant. Port band A and A'' IS95

A'' and A Band IS95 Spurious emissions 10kHz-400 MHz

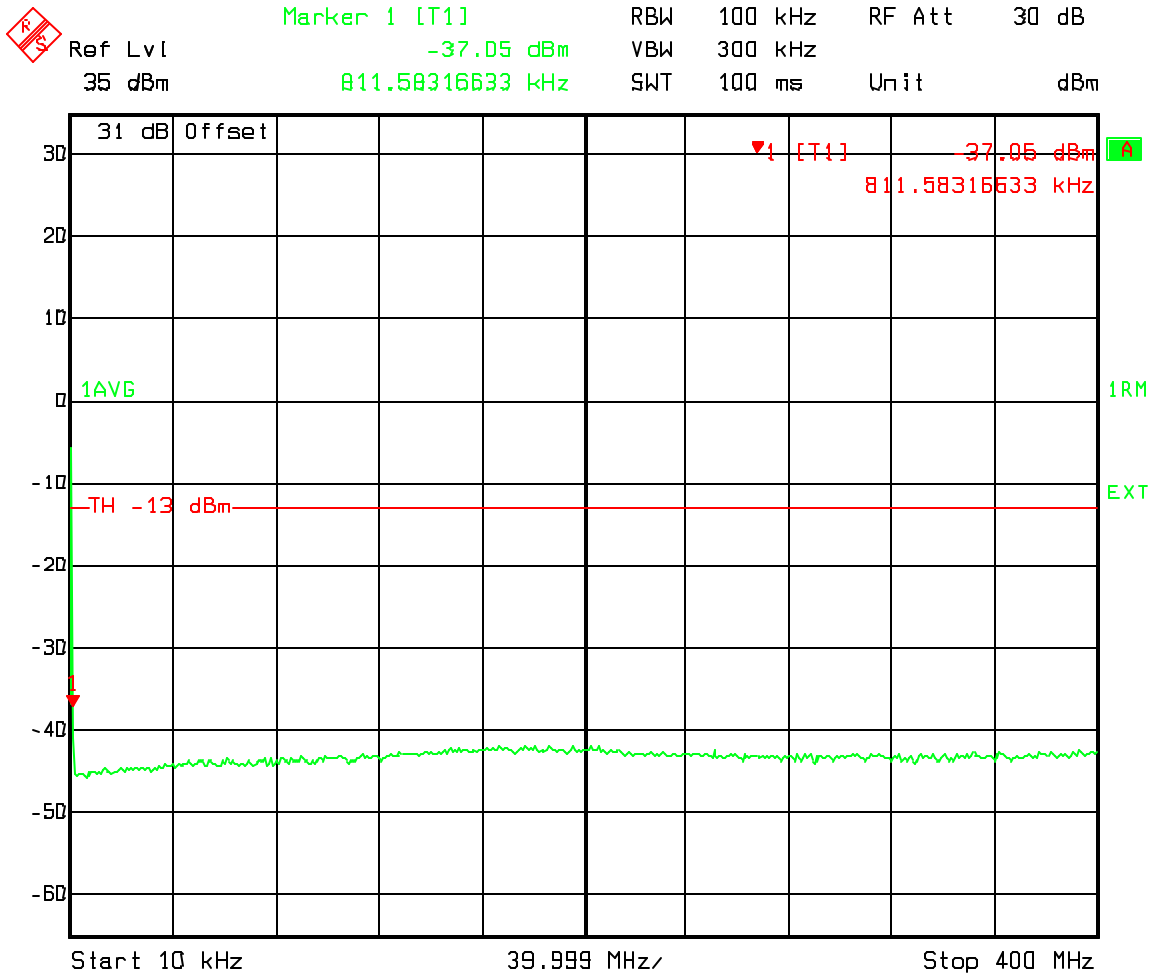

Date: 12.JAN.2004 23:11:19

Two Carrier 1015, 33 and 267, 308 Spurious Emissions at the 800 MHz MFRM2 Ant. Port band A and A'' IS95

A'' and A Band IS95 Spurious emissions 400MHz to Lower 1MHz Band Edge

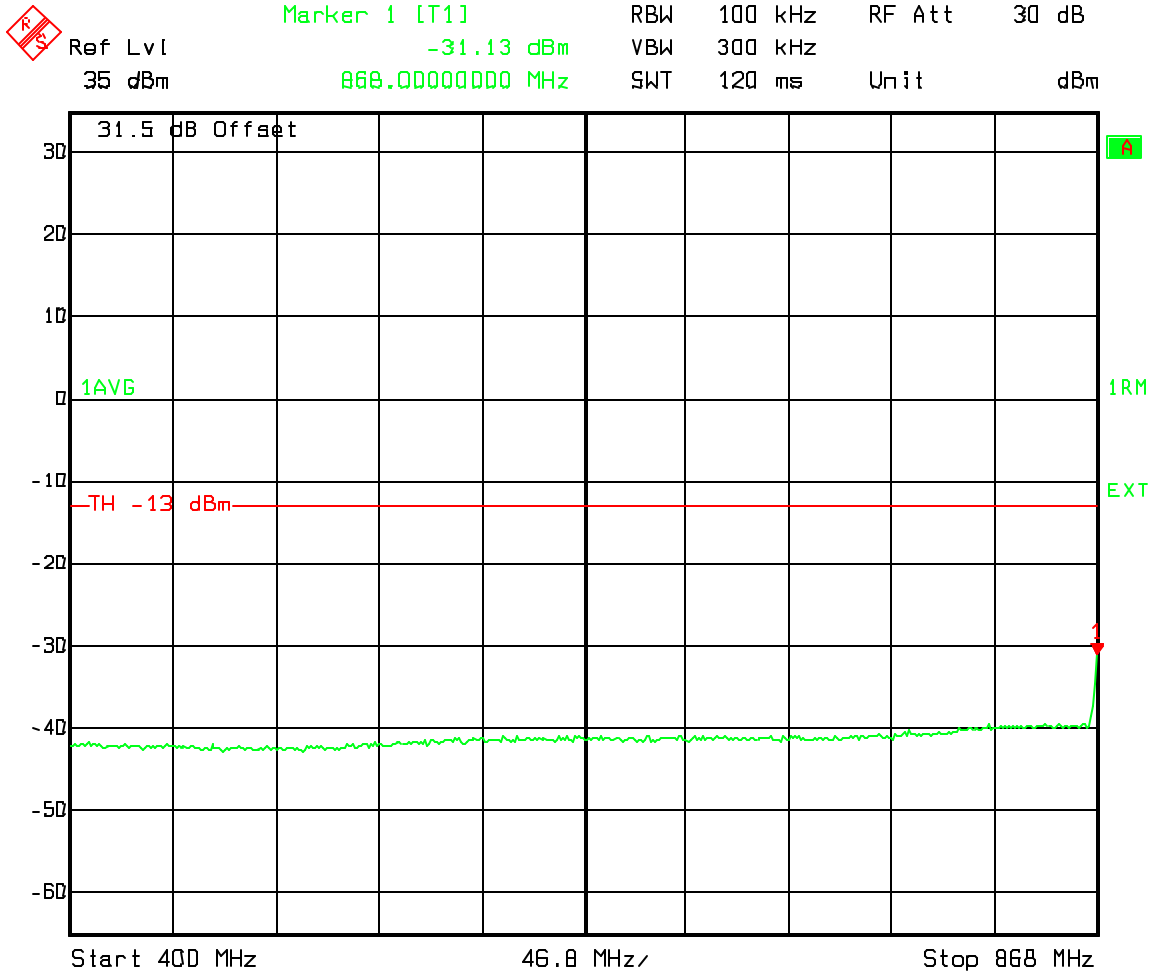

Date: 7.FEB.2004 11:31:56

Two Carrier 1015, 33 and 267, 308 Spurious Emissions at the 800 MHz MFRM2 Ant. Port band A and A'' IS95

A'' and A Band IS95 Spurious emissions Upper 1MHz Band Edge to 1GHz

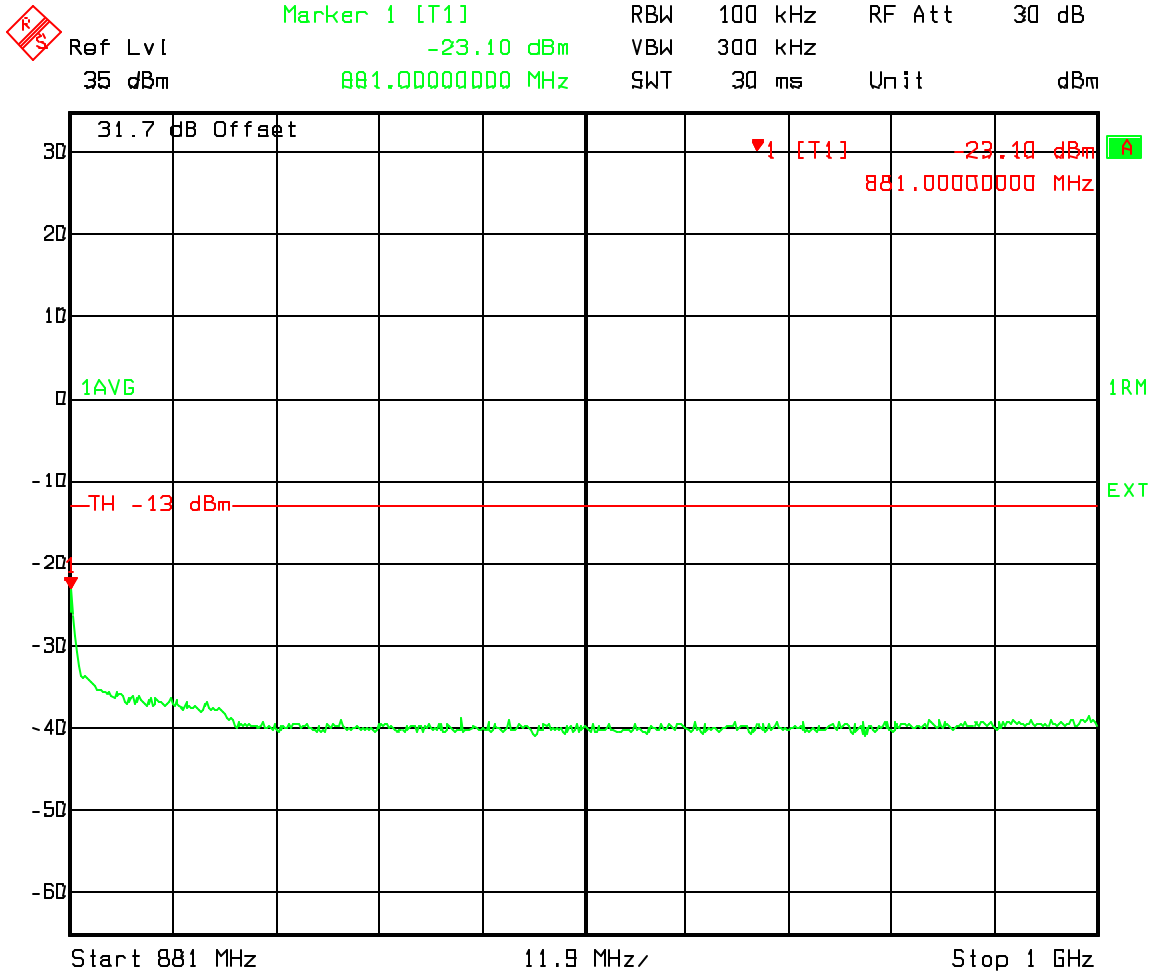

Date: 6.FEB.2004 10:44:18

**Two Carrier 1015, 33 and 267, 308 Spurious Emissions at the 800 MHz MFRM2
Ant. Port band A and A'' IS95**

A'' and A Band IS95 Spurious emissions 400-1000 MHz

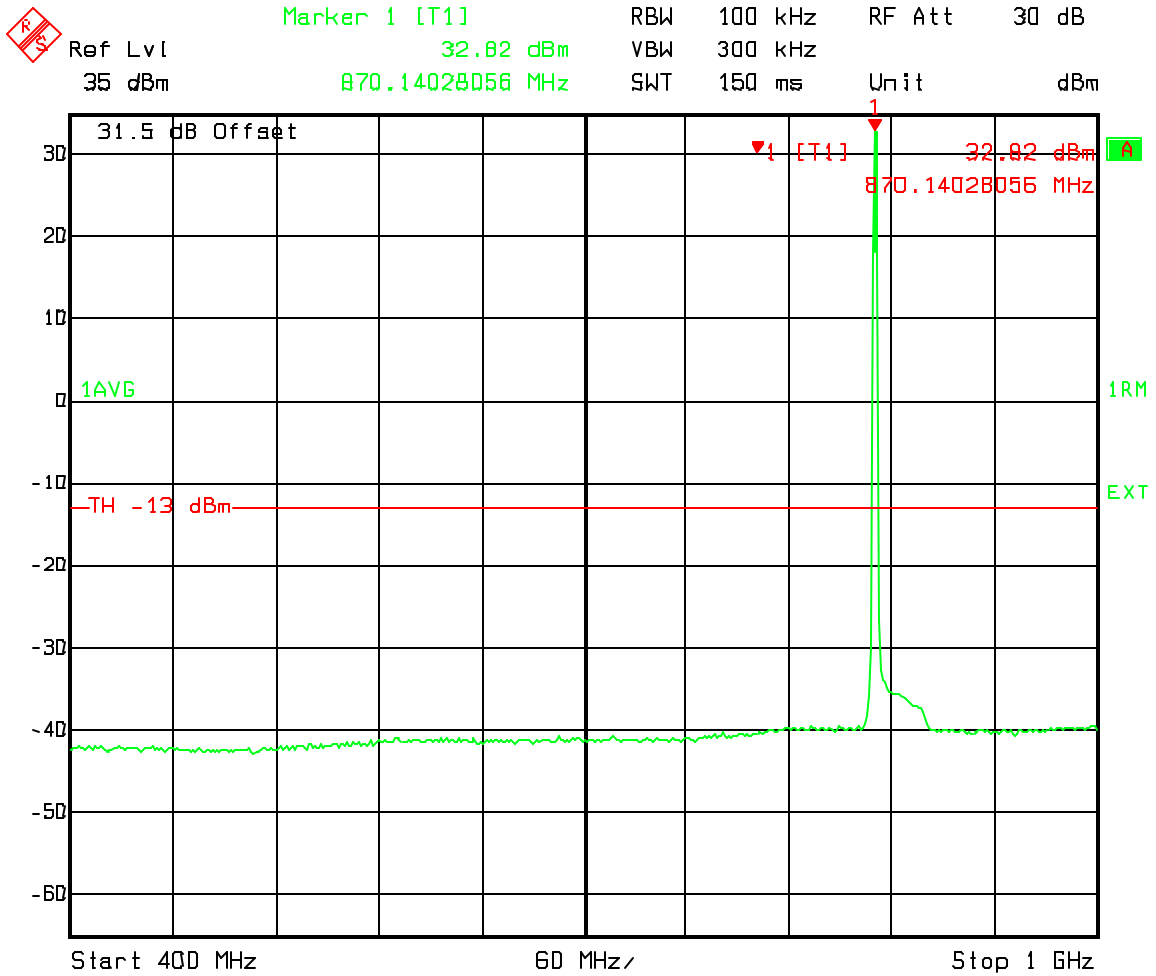

Date: 12.JAN.2004 23:12:03

**Two Carrier 1015, 33 and 267, 308 Spurious Emissions at the 800 MHz MFRM2
Ant. Port band A and A'' IS95**

A'' and A Band IS95 Spurious emissions 1000-2000 MHz

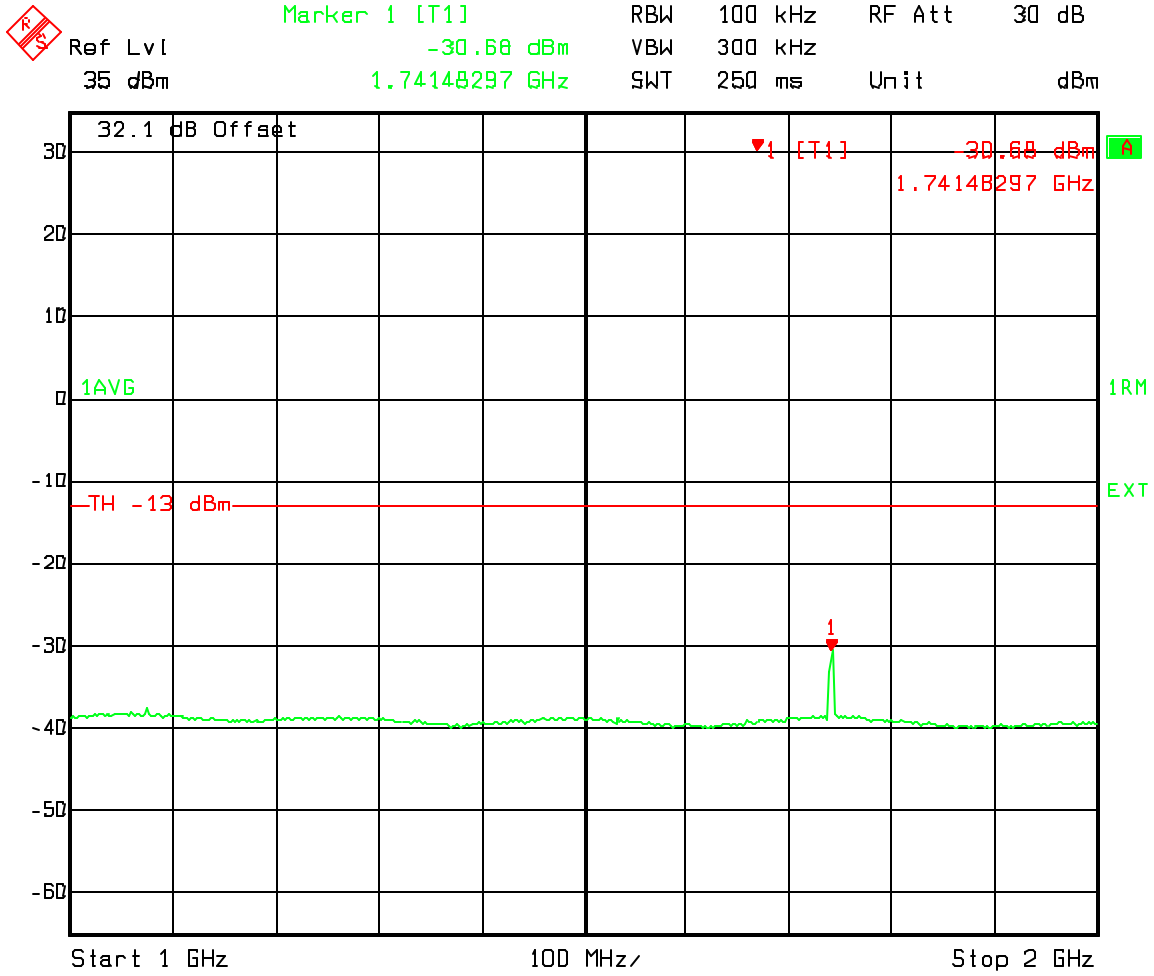

Date: 12.JAN.2004 23:12:47

Two Carrier 1015, 33 and 267, 308 Spurious Emissions at the 800 MHz MFRM2 Ant. Port band A and A'' IS95

A'' and A Band IS95 Spurious emissions 2000-3000 MHz

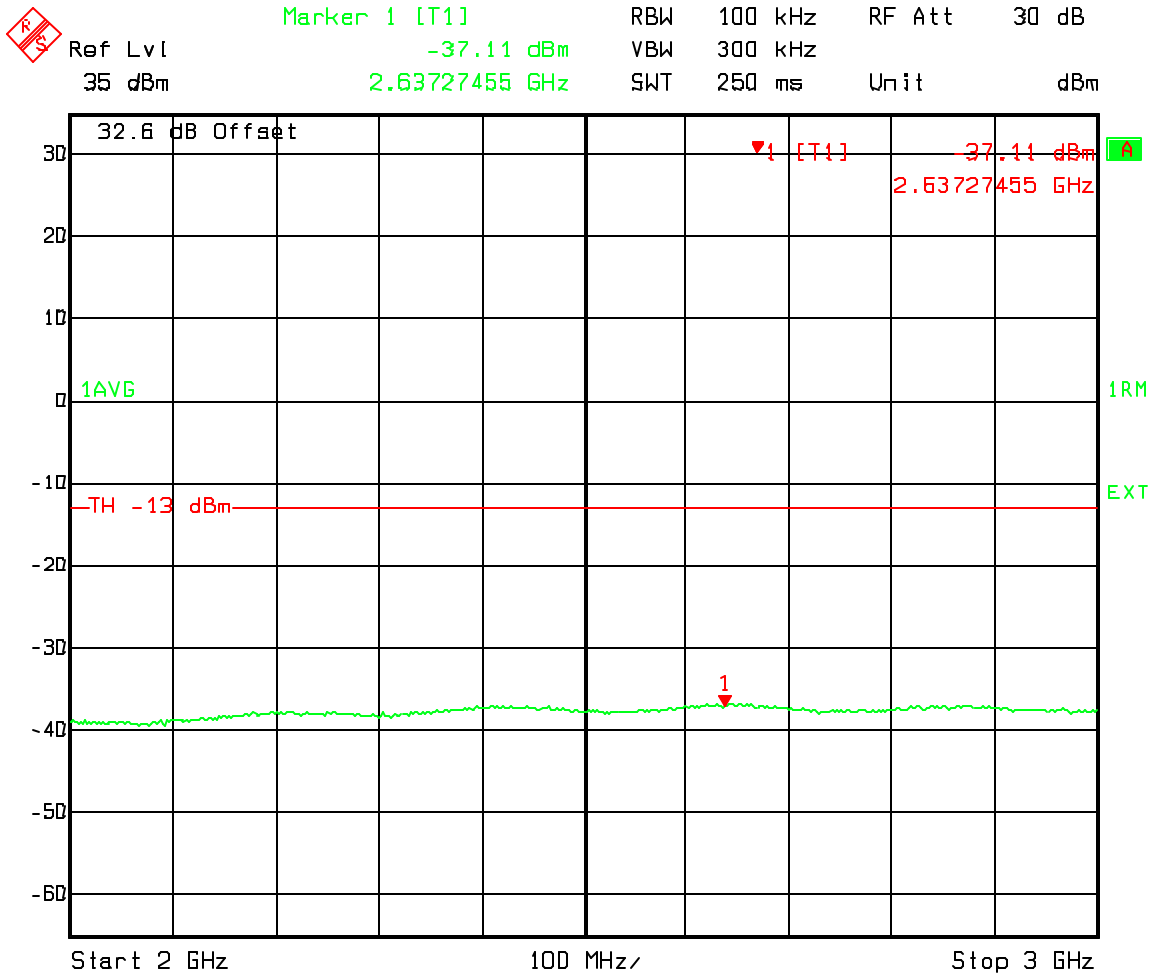

Date: 12.JAN.2004 23:13:30

Two Carrier 1015, 33 and 267, 308 Spurious Emissions at the 800 MHz MFRM2 Ant. Port band A and A'' IS95

A'' and A Band IS95 Spurious emissions 3000-4000 MHz

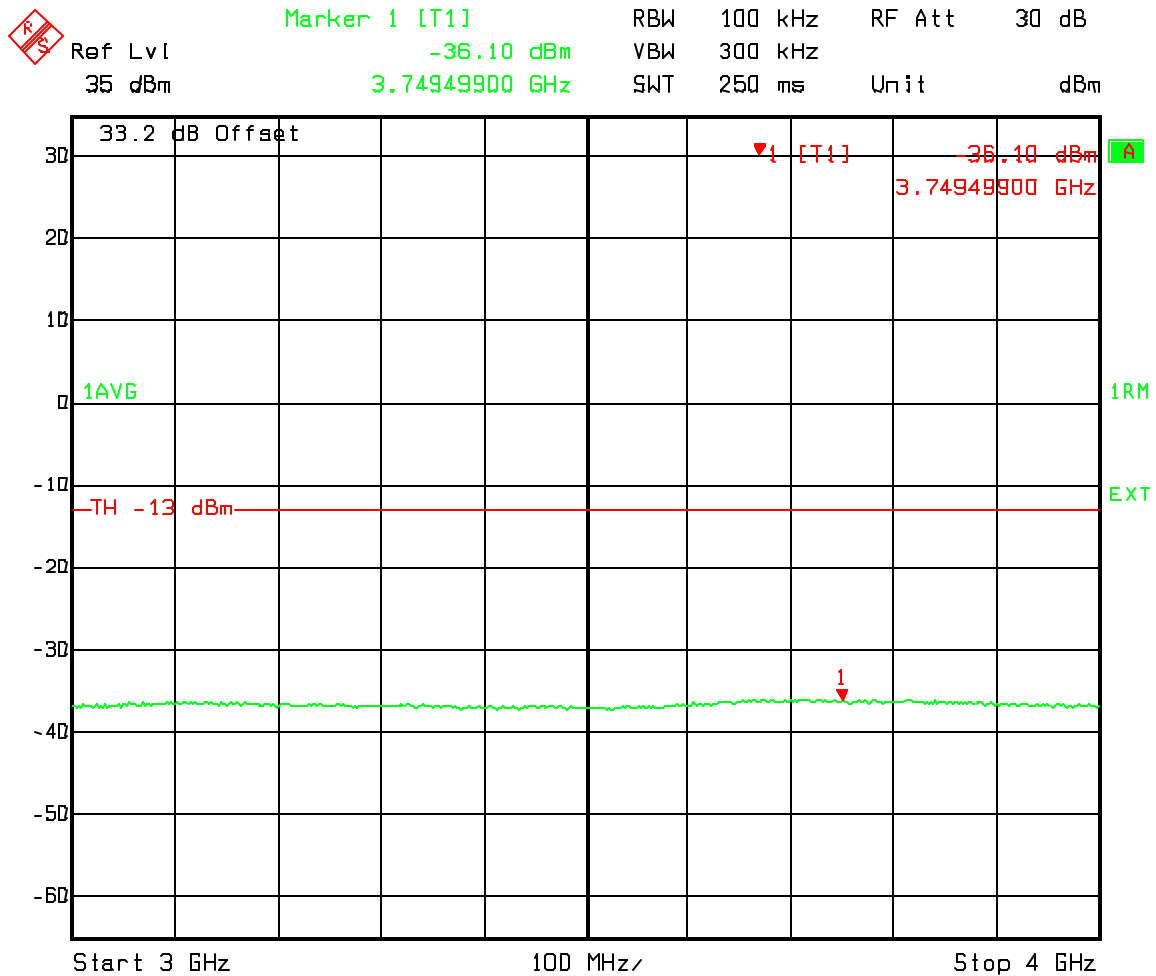

Date: 12.JAN.2004 23:14:14

Two Carrier 1015, 33 and 267, 308 Spurious Emissions at the 800 MHz MFRM2 Ant. Port band A and A'' IS95

A'' and A Band IS95 Spurious emissions 4000-5000 MHz

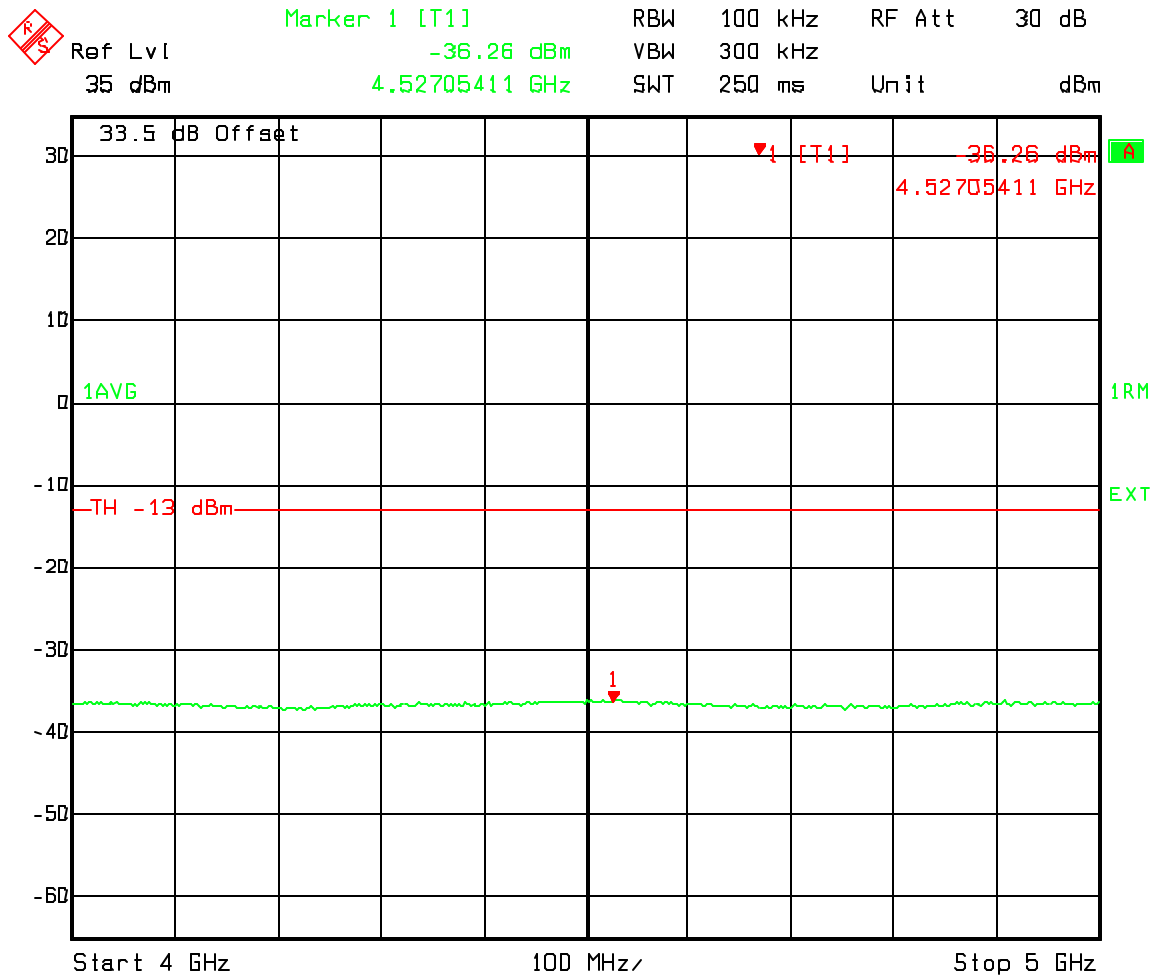

Date: 12.JAN.2004 23:14:59

Two Carrier 1015, 33 and 267, 308 Spurious Emissions at the 800 MHz MFRM2 Ant. Port band A and A'' IS95

A'' and A Band IS95 Spurious emissions 5000-6000 MHz

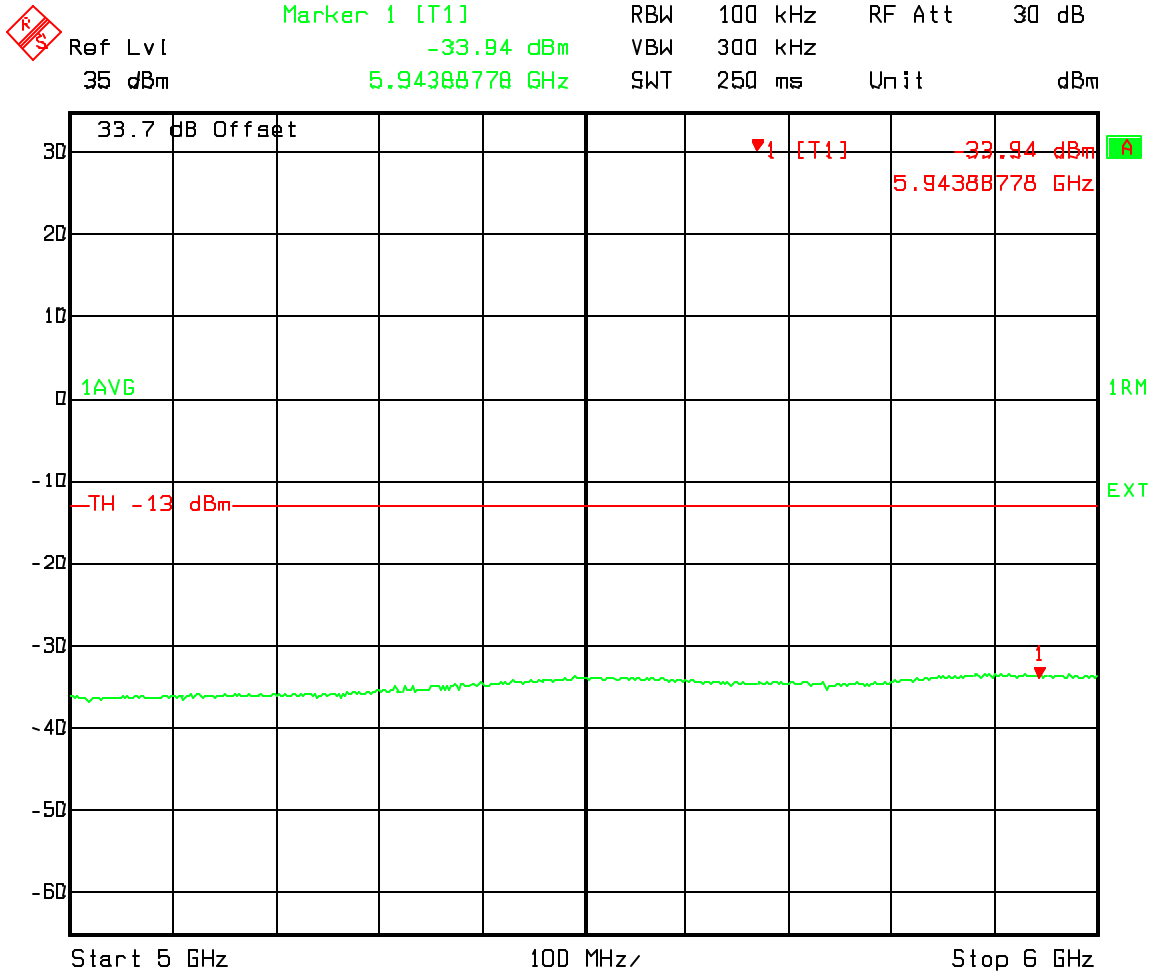

Date: 12.JAN.2004 23:15:43

Two Carrier 1015, 33 and 267, 308 Spurious Emissions at the 800 MHz MFRM2 Ant. Port band A and A'' IS95

A'' and A Band IS95 Spurious emissions 6000-7000 MHz

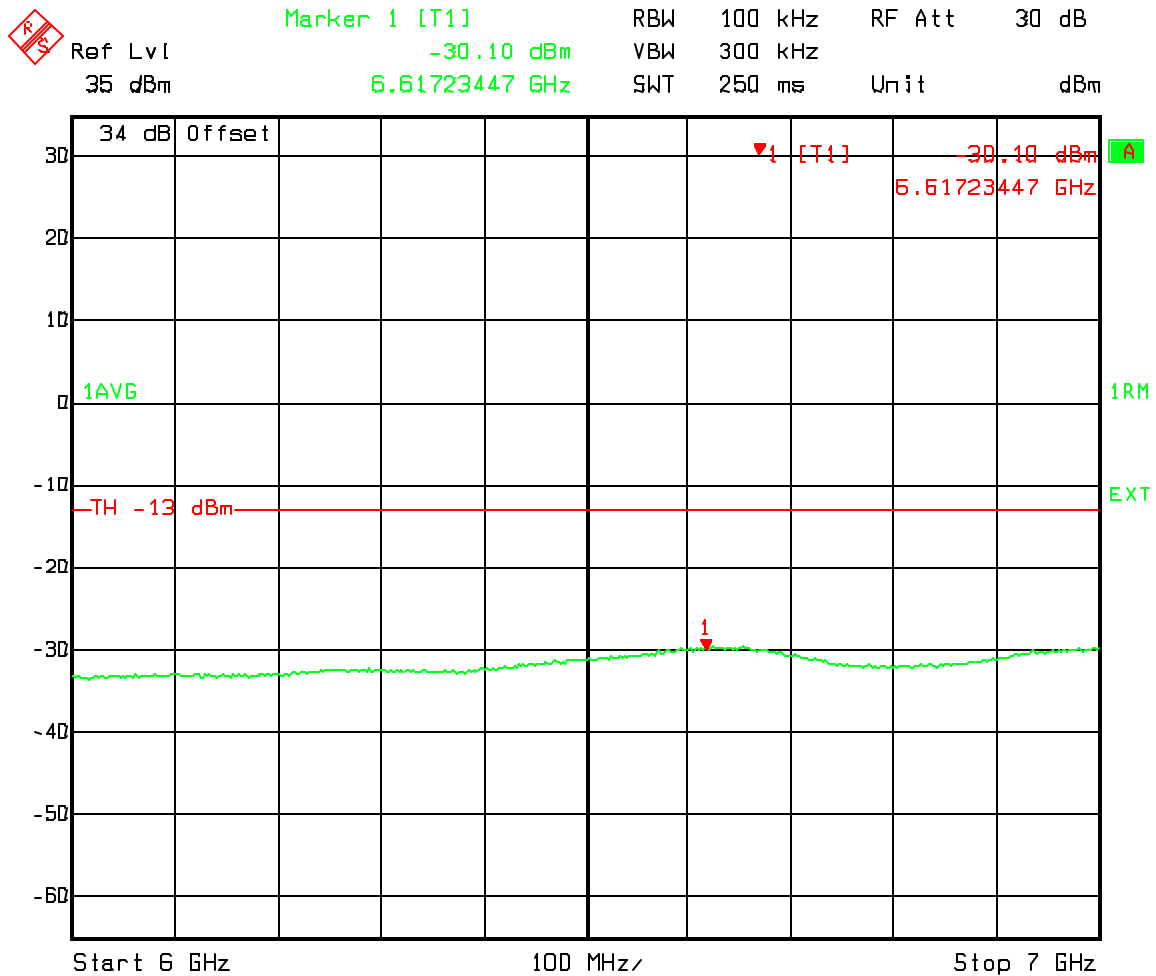

Date: 12.JAN.2004 23:16:29

Two Carrier 1015, 33 and 267, 308 Spurious Emissions at the 800 MHz MFRM2 Ant. Port band A and A'' IS95

A'' and A Band IS95 Spurious emissions 7000-8000 MHz

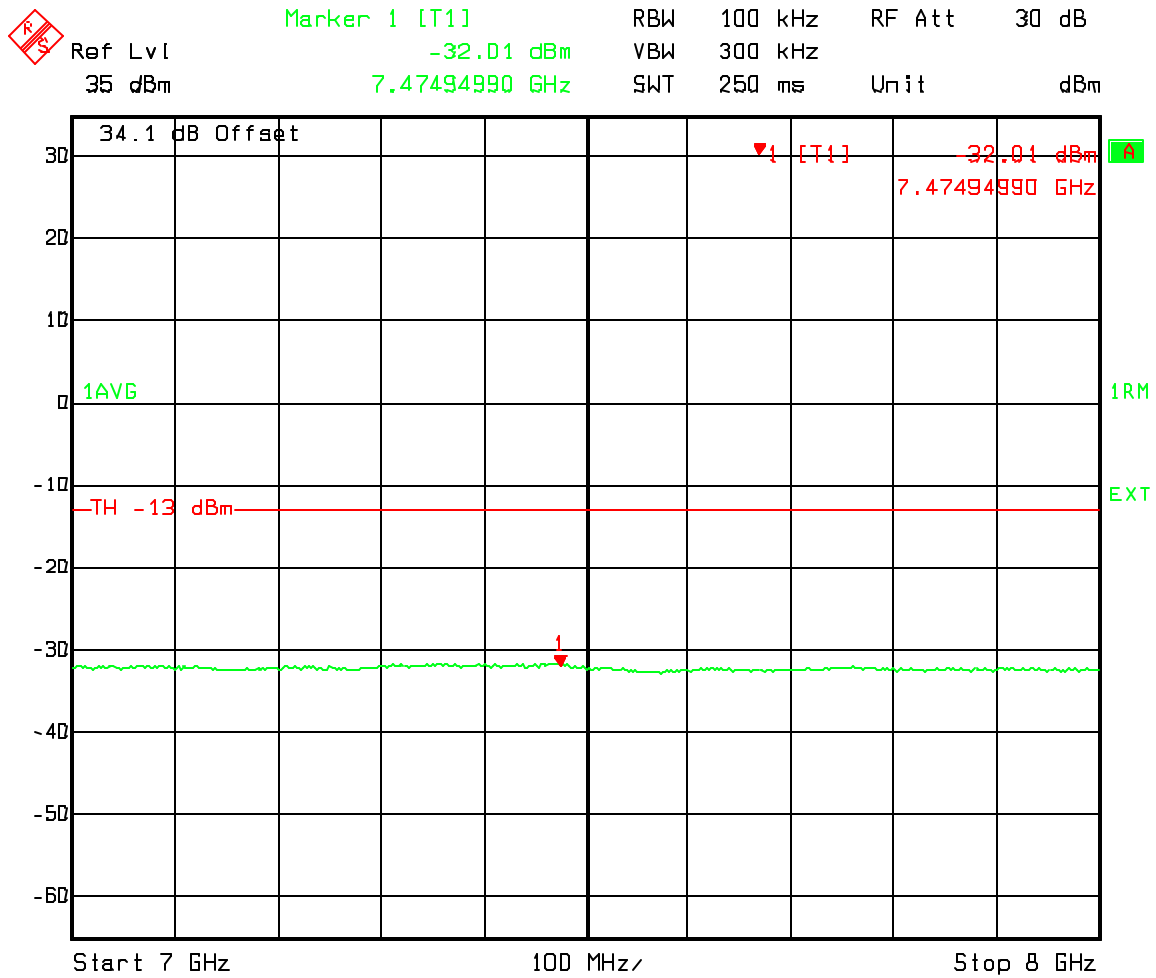

Date: 12.JAN.2004 23:17:17

**Two Carrier 1015, 33 and 267, 308 Spurious Emissions at the 800 MHz MFRM2
Ant. Port band A and A'' IS95**

A'' and A Band IS95 Spurious emissions 8000-9000 MHz

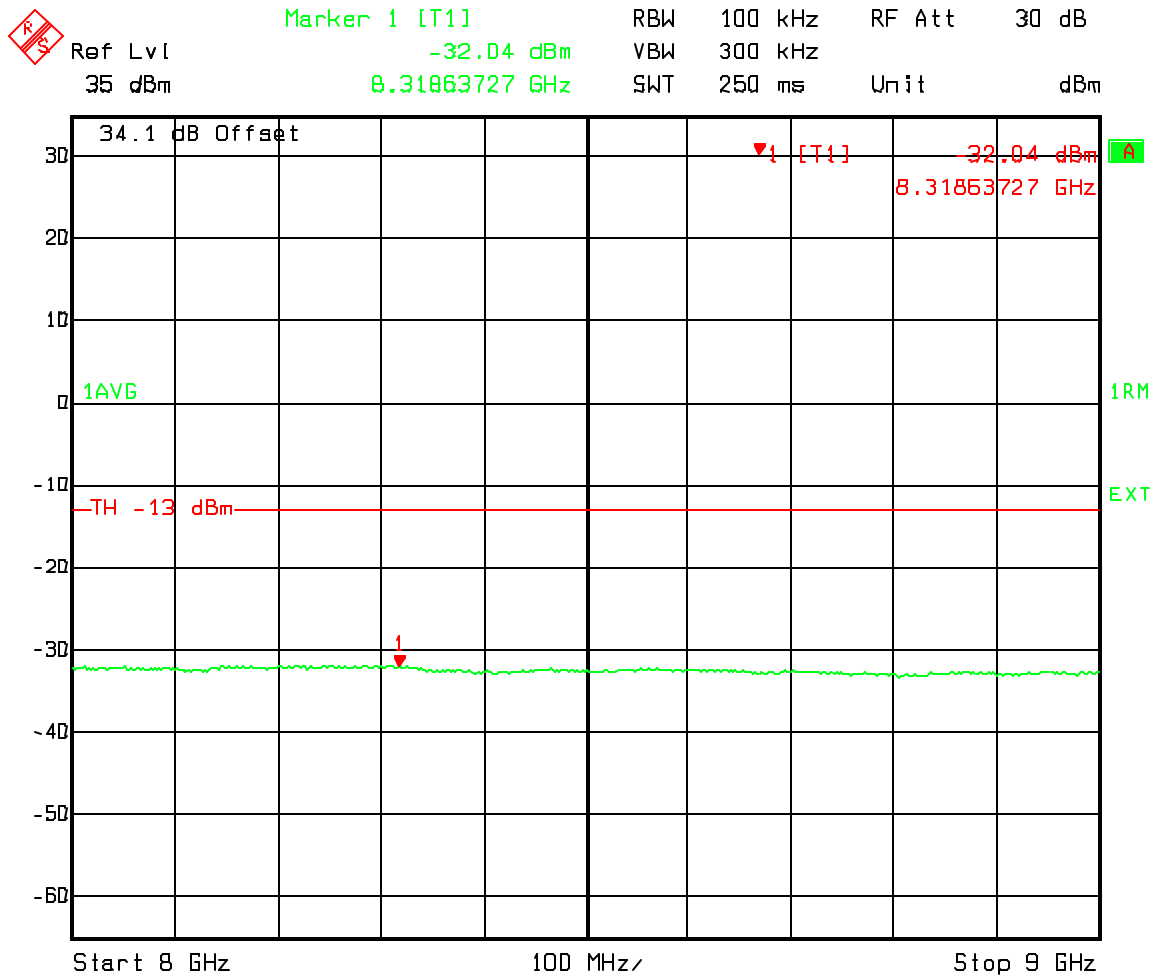

Date: 12.JAN.2004 23:18:02

Two Carrier 1015, 33 and 267, 308 Spurious Emissions at the 800 MHz MFRM2 Ant. Port band A and A'' IS95

A'' and A Band IS95 Spurious emissions 9000-10000 MHz

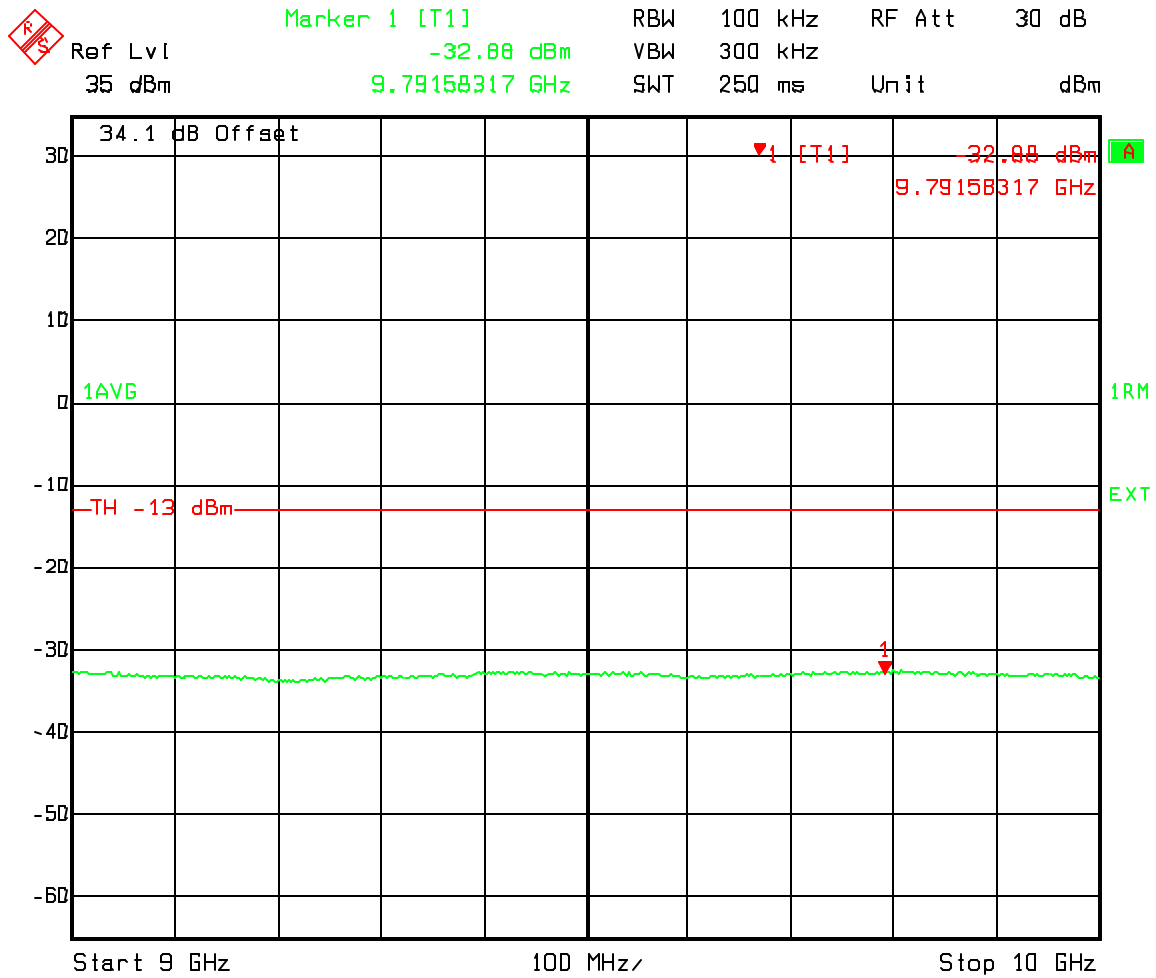

Date: 12.JAN.2004 23:18:47

Three Carrier Channel 1015, 33, 74 and 226, 267, 308 Spurious Emissions at the 800 MHz MFRM2 Ant. Port band A and A'' IS95

Occupied Bandwidth Ch 1015, 33, 74A''

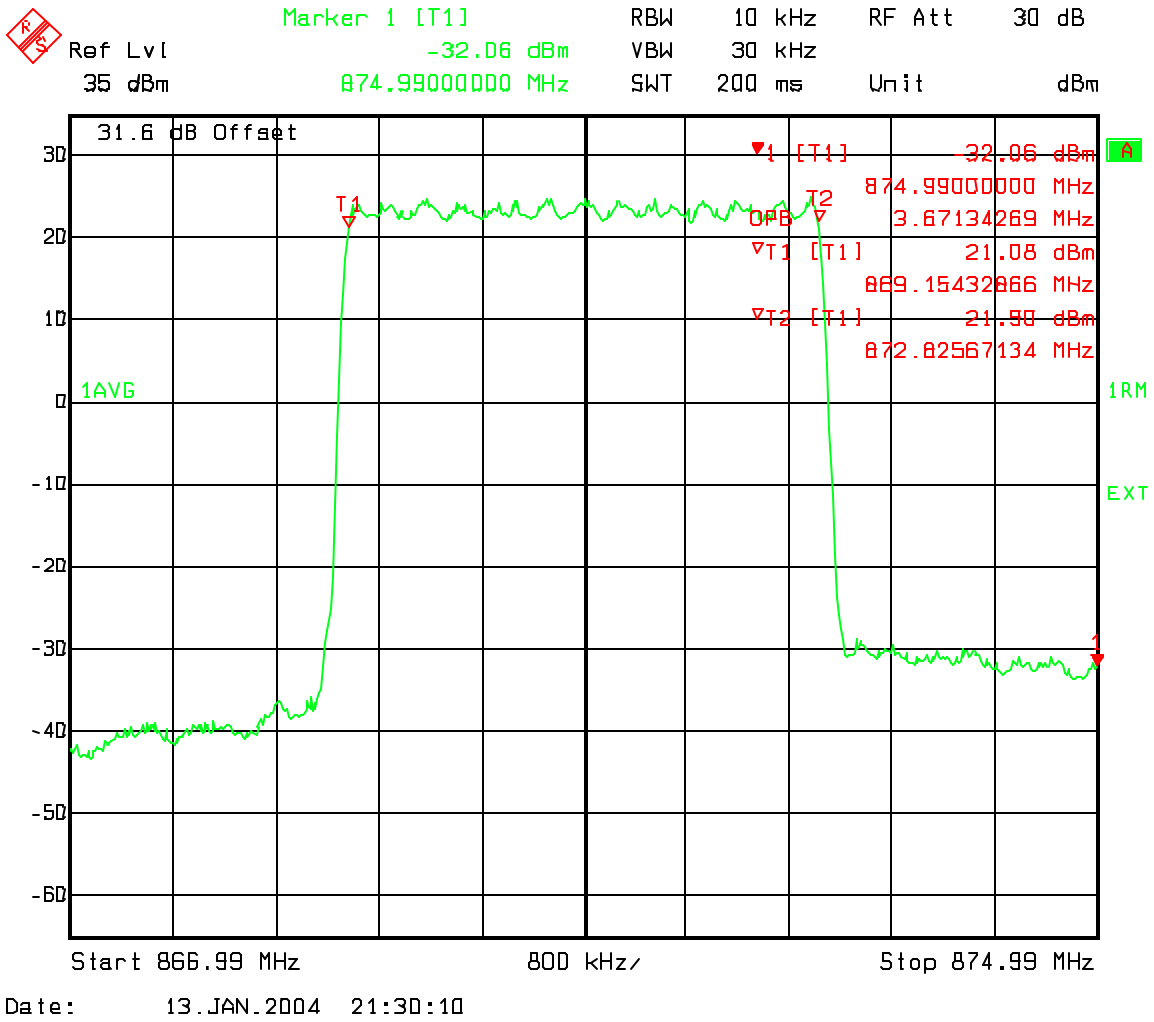

Three Carrier Channel 1015, 33, 74 and 226, 267, 308 Spurious Emissions at the 800 MHz MFRM2 Ant. Port band A and A'' IS95

A'' Band Ch 1015, 33, 74 IS95 Adjacent 1Mhz Lower emissions 868-869MHz

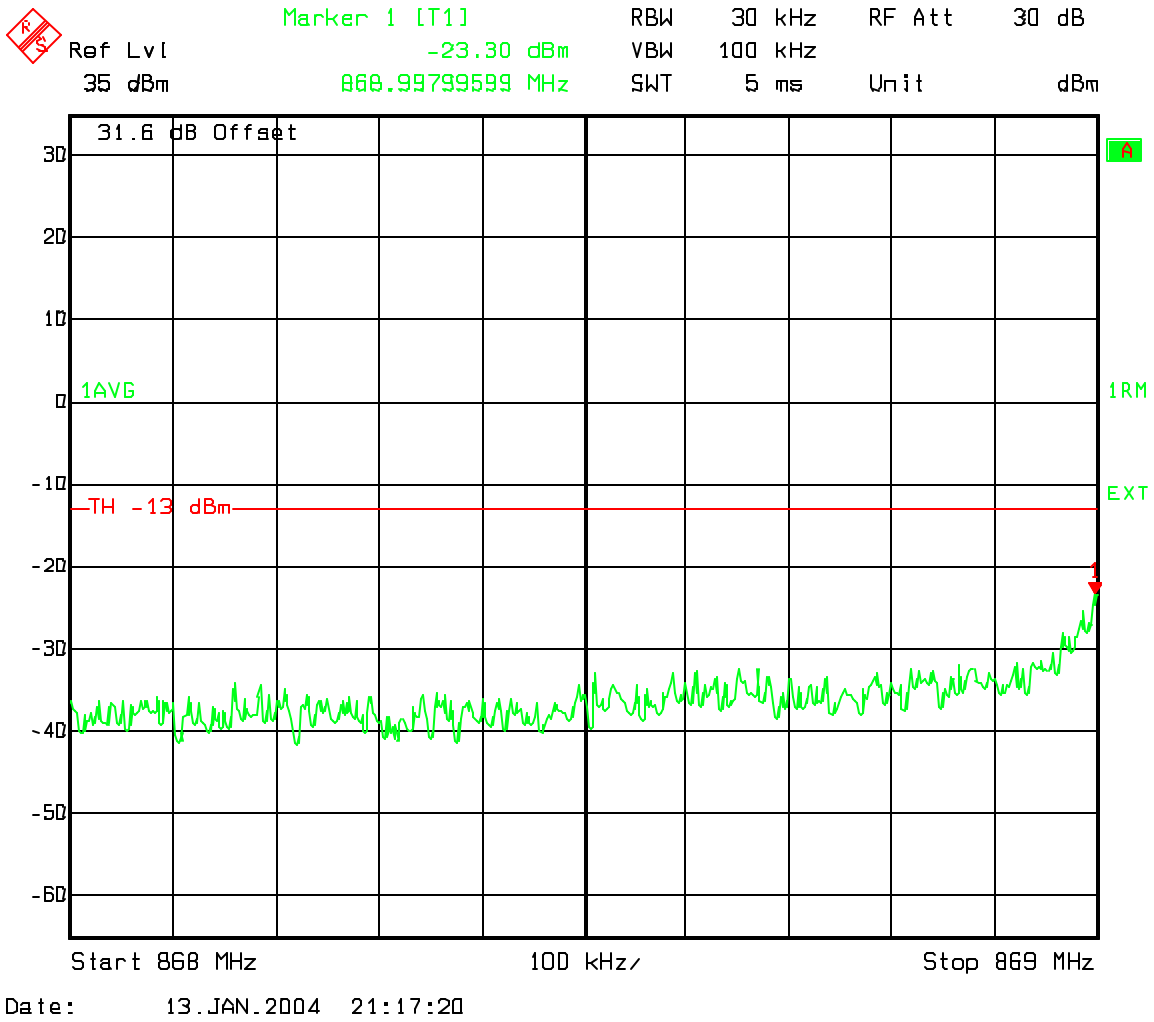

Three Carrier Channel 1015, 33, 74 and 226, 267, 308 Spurious Emissions at the 800 MHz MFRM2 Ant. Port band A and A'' IS95

A'' Band Ch1015, 33, 74 IS95 Channel power Adjacent 37.5 kHz Lower emissions to 869 MHz

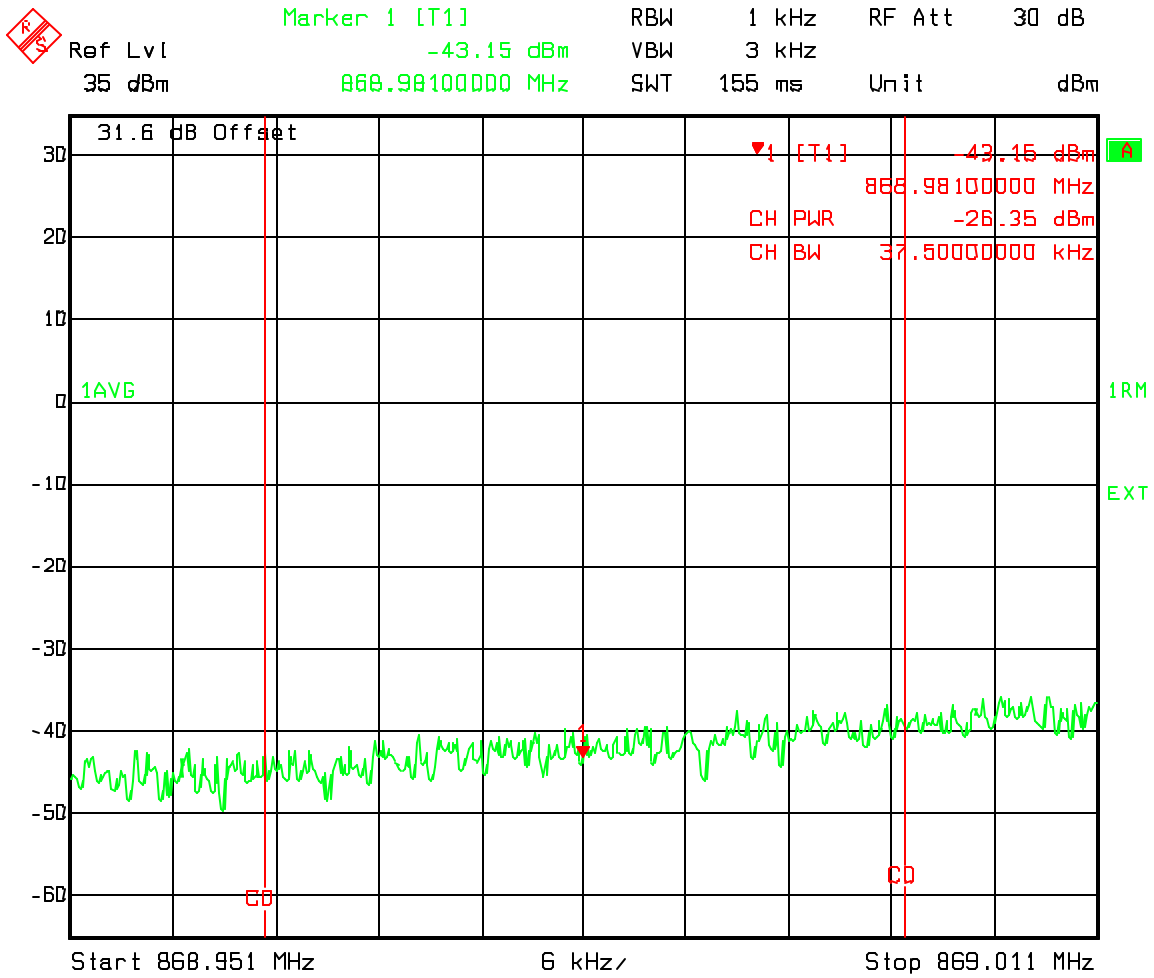

Date: 13.JAN.2004 21:18:09

Three Carrier Channel 1015, 33, 74 and 226, 267, 308 Spurious Emissions at the 800 MHz MFRM2 Ant. Port band A and A'' IS95

Ch 226, 267, 308 Upper A Band adjacent 1MHz band emissions 880-881 MHz

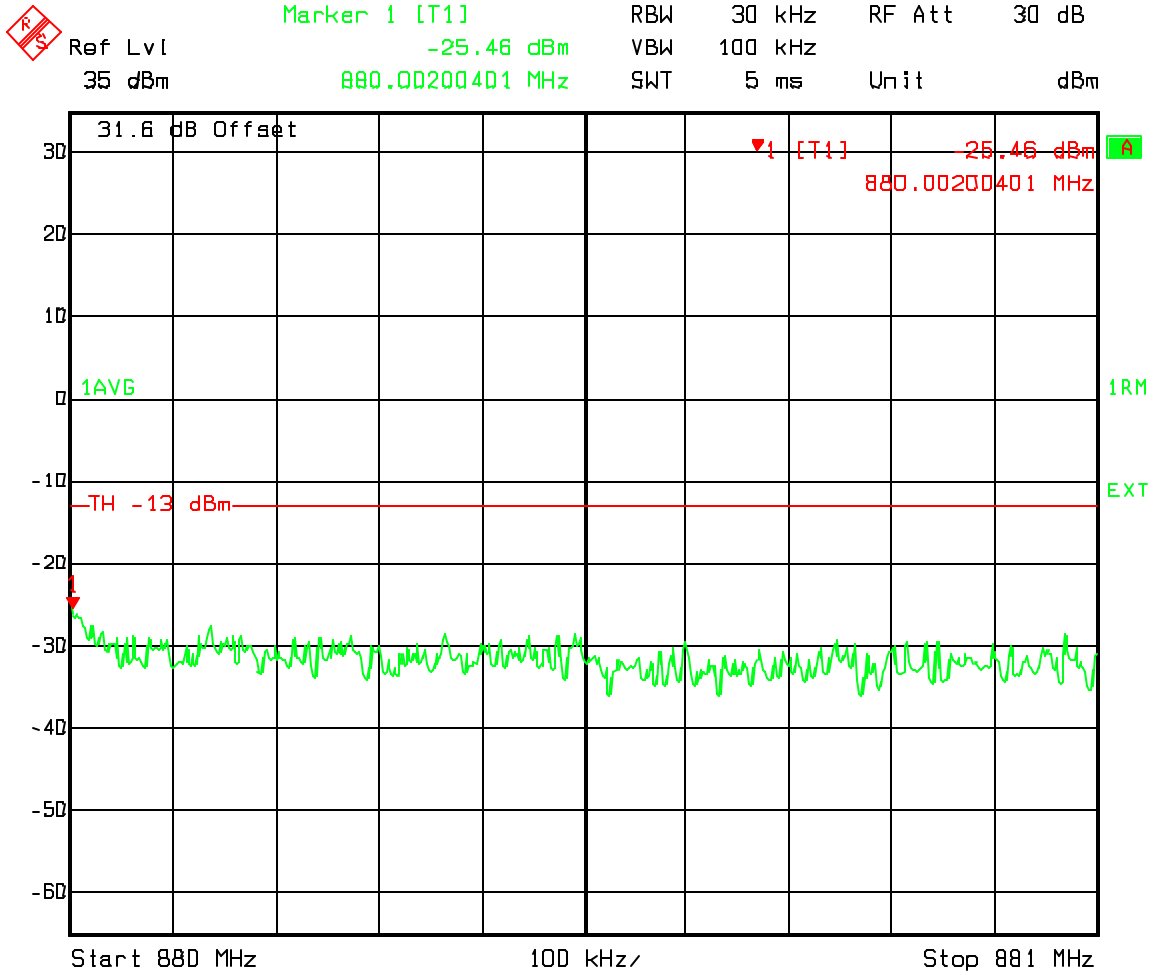

Date: 13.JAN.2004 17:27:48

Three Carrier Channel 1015, 33, 74 and 226, 267, 308 Spurious Emissions at the 800 MHz MFRM2 Ant. Port band A and A'' IS95

Ch 226, 267, 308 Upper A Band adjacent to outside edge 37.5 kHz band Channel power

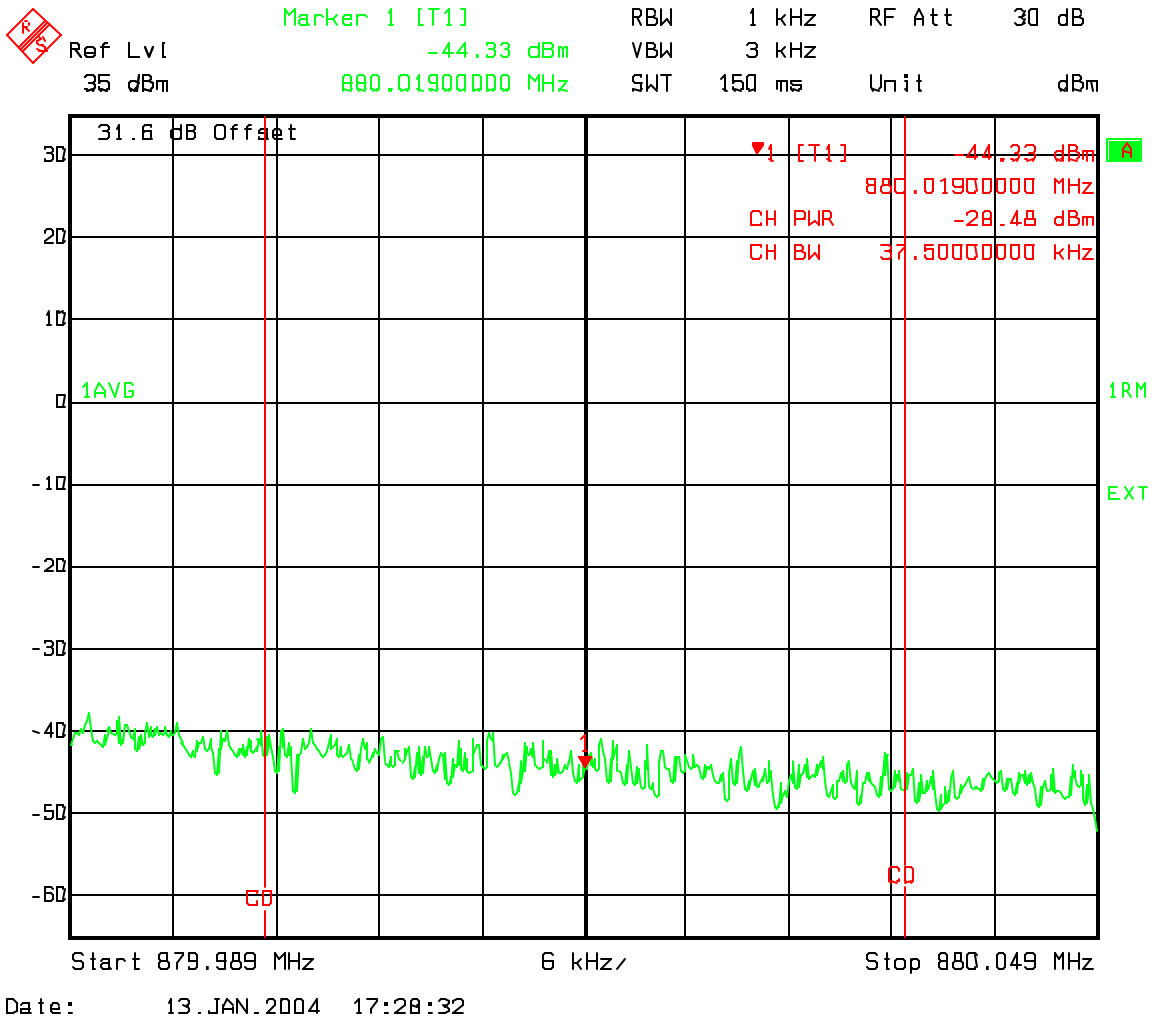

Three Carrier Channel 1015, 33, 74 and 226, 267, 308 Spurious Emissions at the 800 MHz MFRM2 Ant. Port band A and A'' IS95

Industry Canada Lower 750 kHz offset 30kHz Chan Power Ch 1015, 33, 74

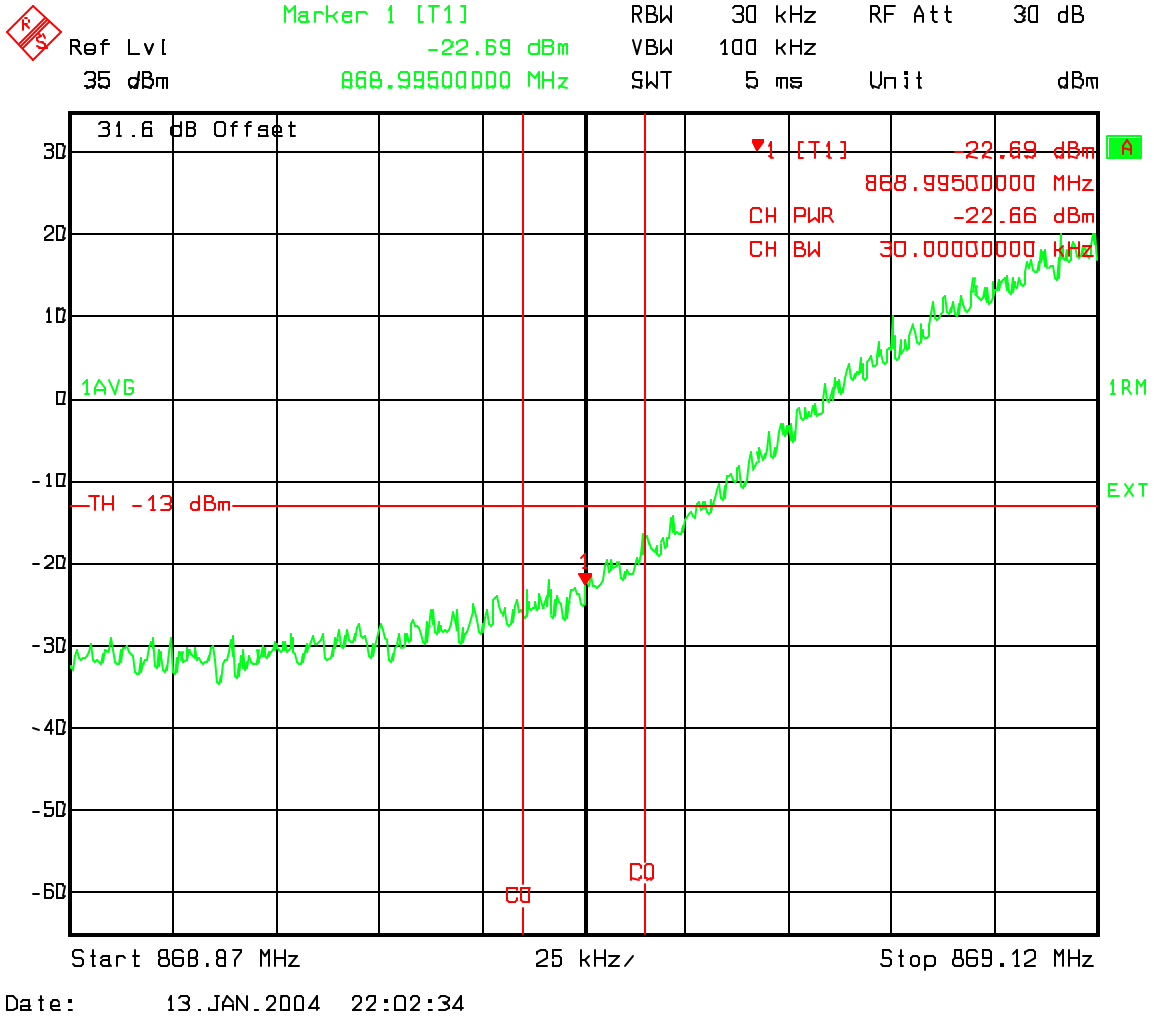

Three Carrier Channel 1015, 33, 74 and 226, 267, 308 Spurious Emissions at the 800 MHz MFRM2 Ant. Port band A and A'' IS95

Industry Canada Upper 750 kHz offset 30kHz Chan Power Ch 1015, 33, 74

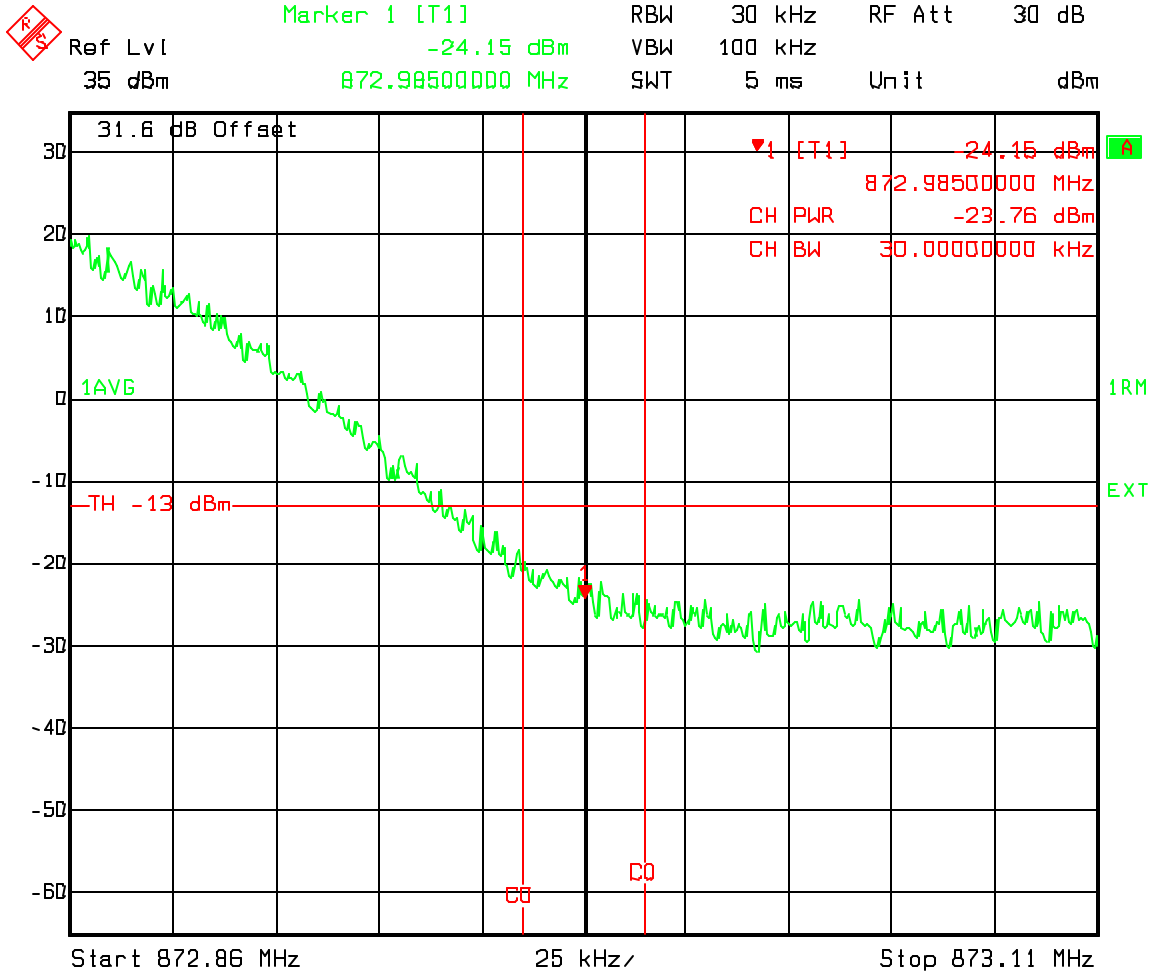

Date: 13.JAN.2004 22:03:25

Three Carrier Channel 1015, 33, 74 and 226, 267, 308 Spurious Emissions at the 800 MHz MFRM2 Ant. Port band A and A'' IS95

Industry Canada 1.98 MHz offset Lower 30kHz Chan Power Ch 1015, 33, 74

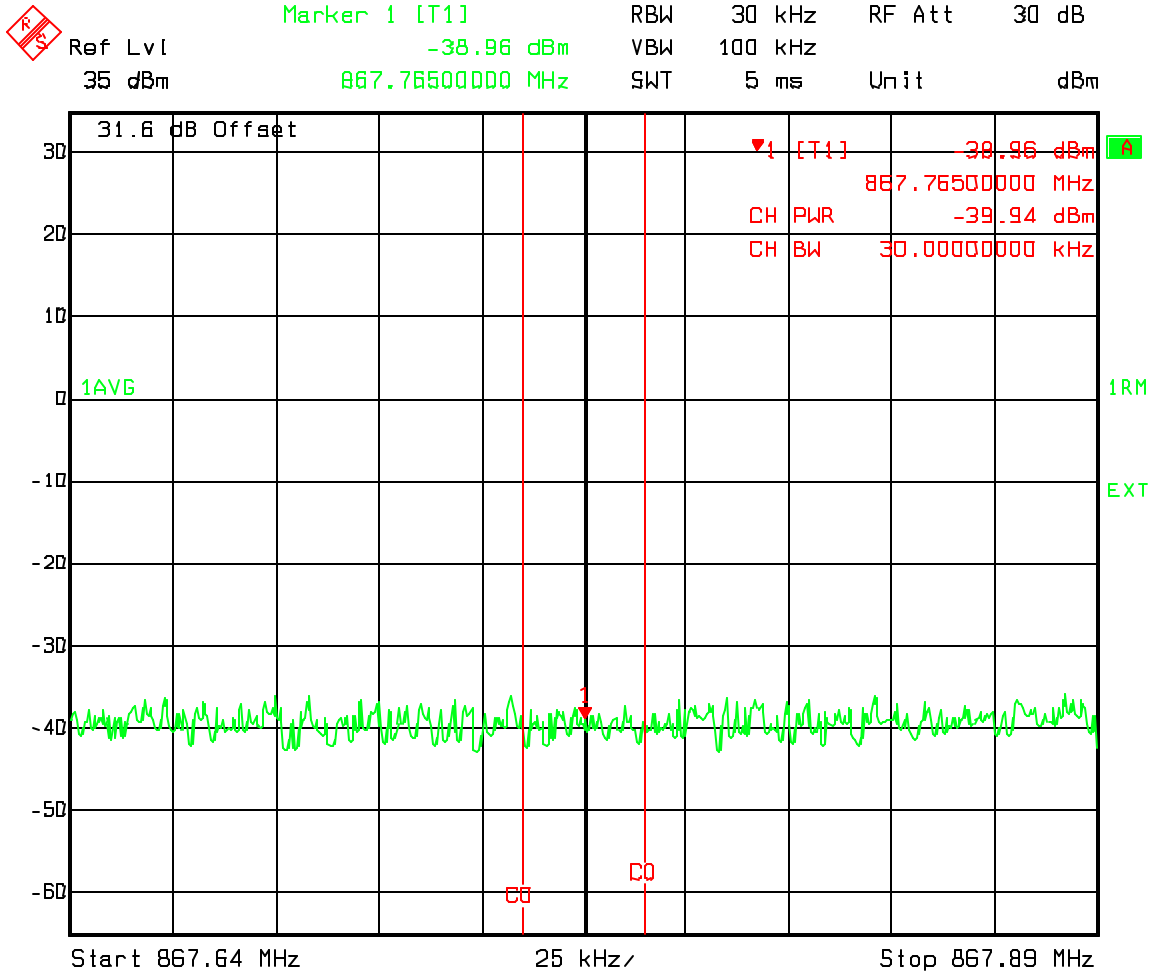

Date: 15.JAN.2004 1:37:02

Three Carrier Channel 1015, 33, 74 and 226, 267, 308 Spurious Emissions at the 800 MHz MFRM2 Ant. Port band A and A'' IS95

Industry Canada 1.98 MHz offset Upper 30kHz Chan Power Ch 1015, 33, 74

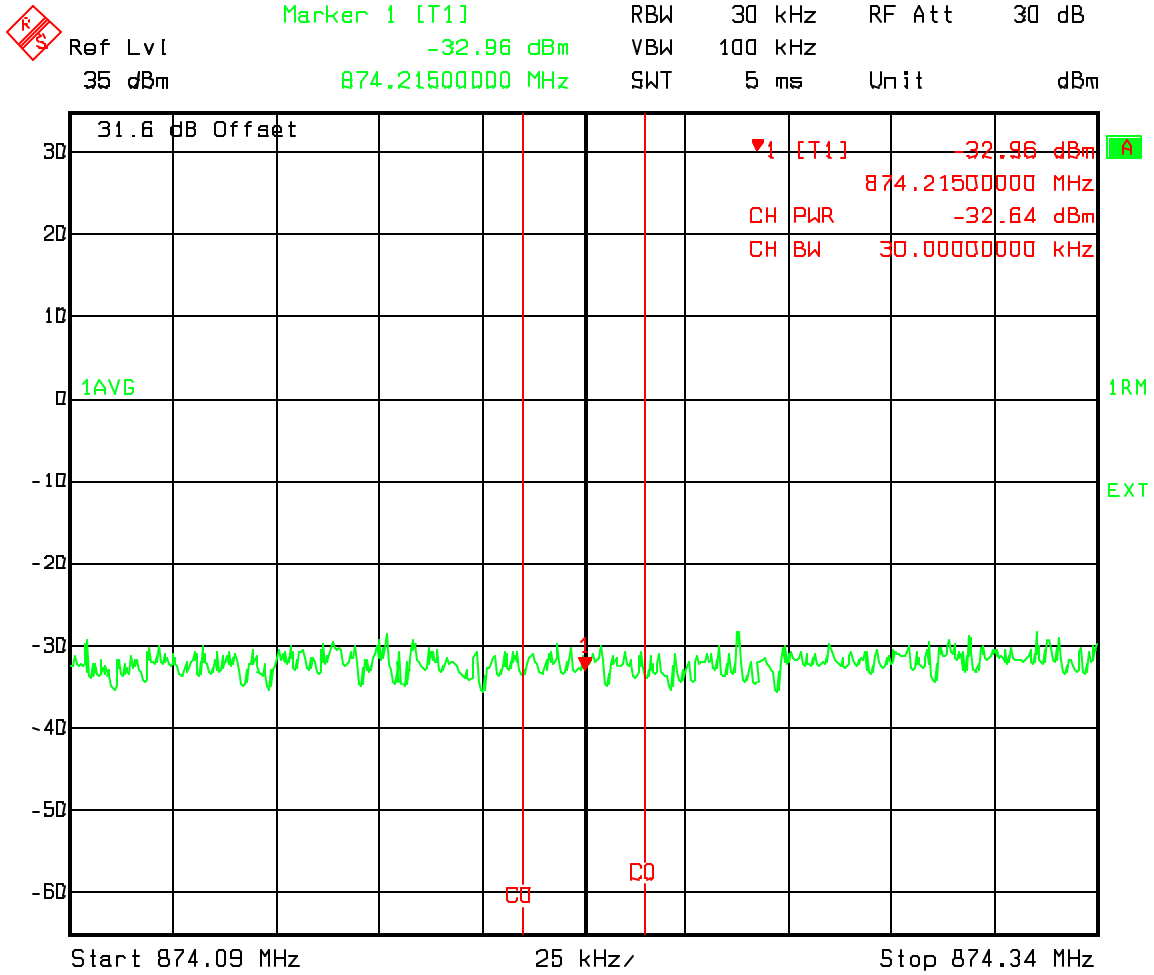

Date: 15.JAN.2004 1:37:55

Three Carrier Channel 1015, 33, 74 and 226, 267, 308 Spurious Emissions at the 800 MHz MFRM2 Ant. Port band A and A'' IS95

A'' and A Band IS95 Spurious emissions 10kHz-400 MHz

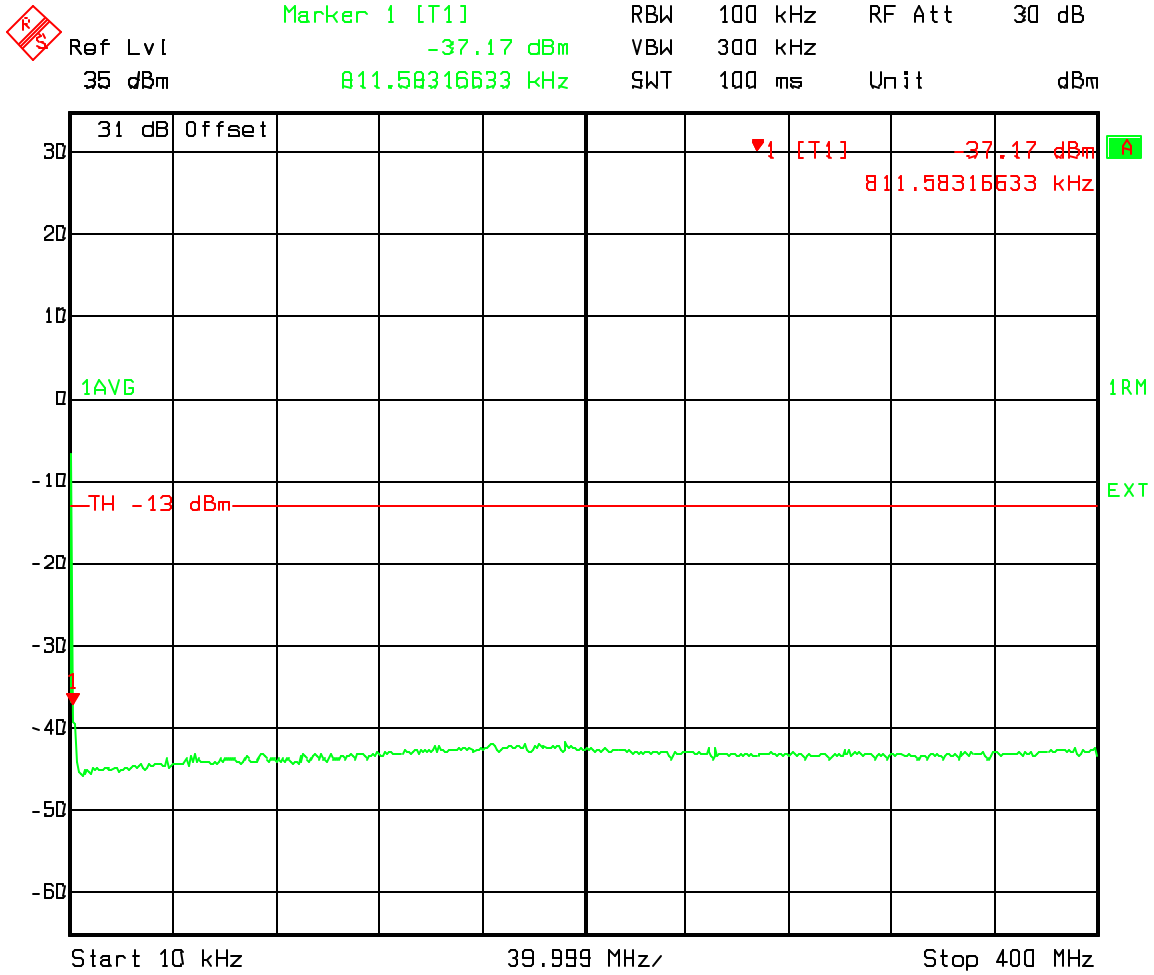

Date: 13.JAN.2004 21:20:47

Three Carrier Channel 1015, 33, 74 and 226, 267, 308 Spurious Emissions at the 800 MHz MFRM2 Ant. Port band A and A'' IS95

A'' and A Band IS95 Spurious emissions 400MHz to Lower 1MHz Band Edge

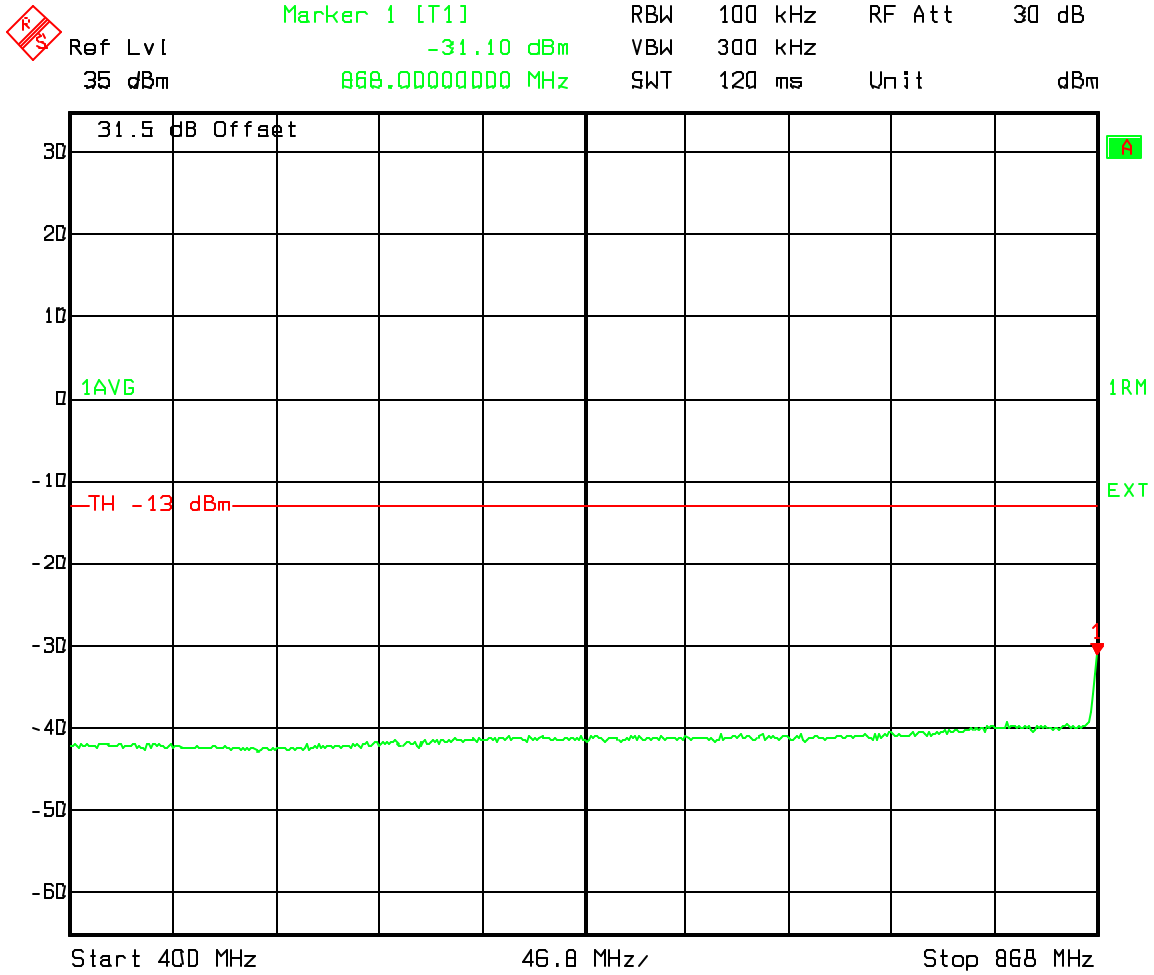

Date: 7.FEB.2004 11:44:43

Three Carrier Channel 1015, 33, 74 and 226, 267, 308 Spurious Emissions at the 800 MHz MFRM2 Ant. Port band A and A'' IS95

A'' and A Band IS95 Spurious emissions Upper 1MHz Band Edge to 1GHz

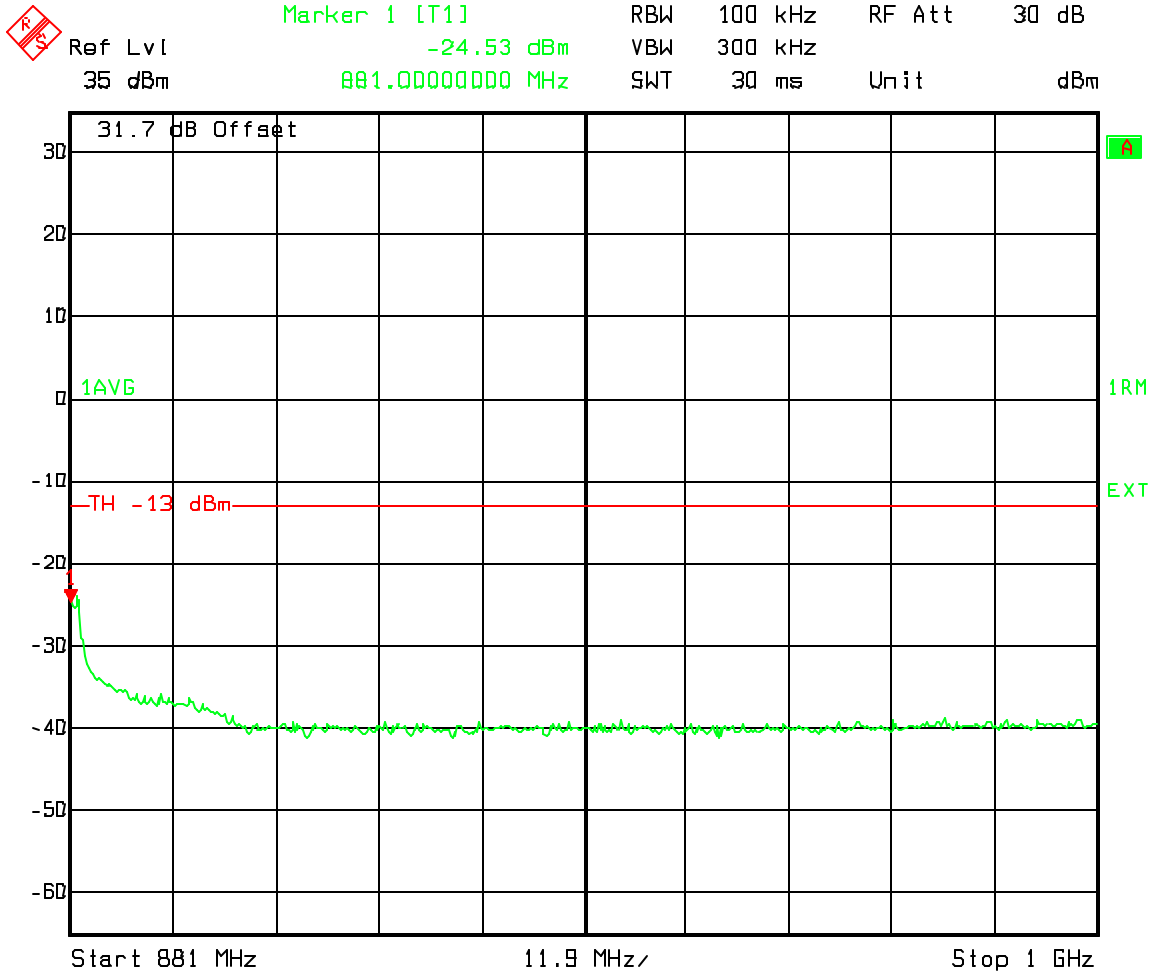

Date: 5.FEB.2004 15:11:27

Three Carrier Channel 1015, 33, 74 and 226, 267, 308 Spurious Emissions at the 800 MHz MFRM2 Ant. Port band A and A'' IS95

A'' and A Band IS95 Spurious emissions 400-1000 MHz

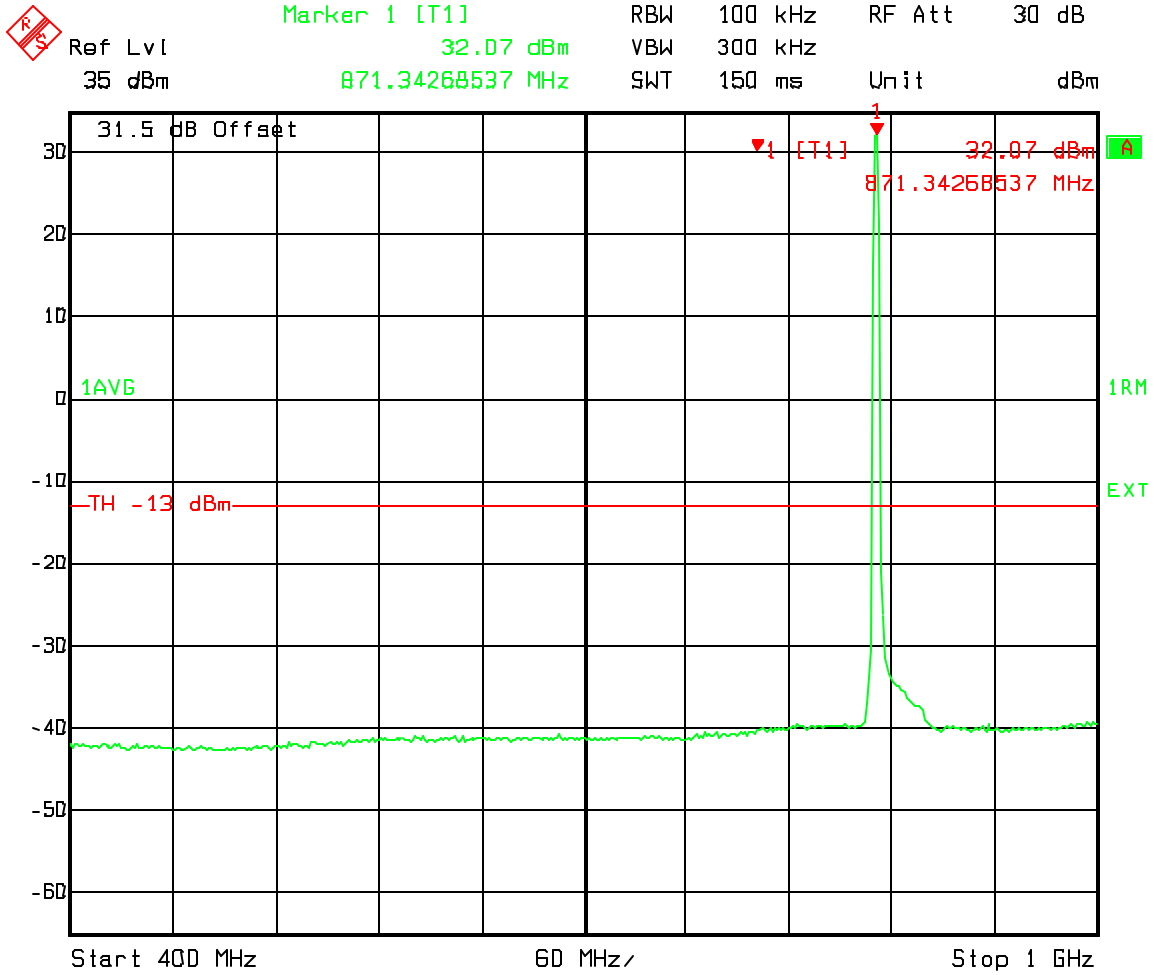

Date: 13.JAN.2004 21:21:38

Three Carrier Channel 1015, 33, 74 and 226, 267, 308 Spurious Emissions at the 800 MHz MFRM2 Ant. Port band A and A'' IS95

A'' and A Band IS95 Spurious emissions 1000-2000 MHz

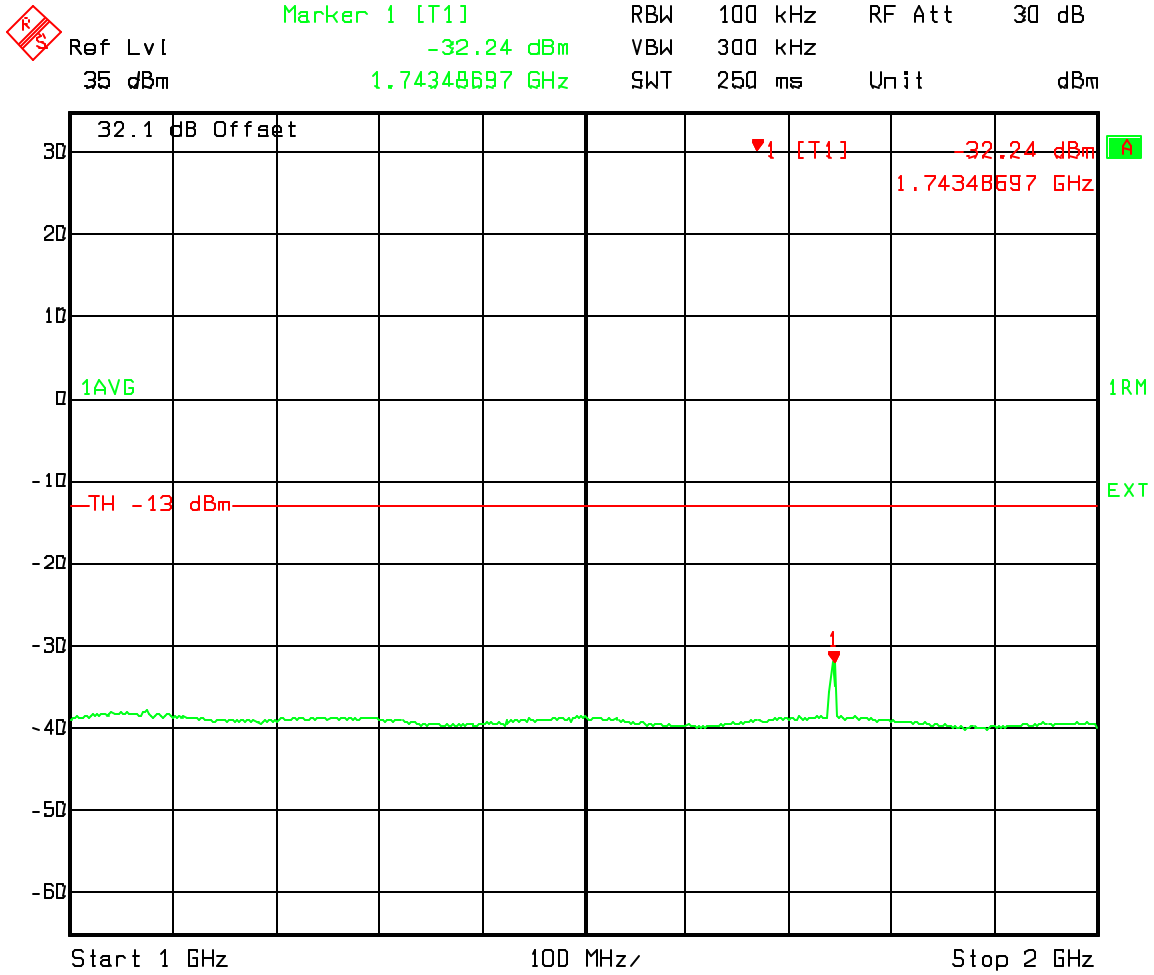

Date: 13.JAN.2004 21:22:28

Three Carrier Channel 1015, 33, 74 and 226, 267, 308 Spurious Emissions at the 800 MHz MFRM2 Ant. Port band A and A'' IS95

A'' and A Band IS95 Spurious emissions 2000-3000 MHz

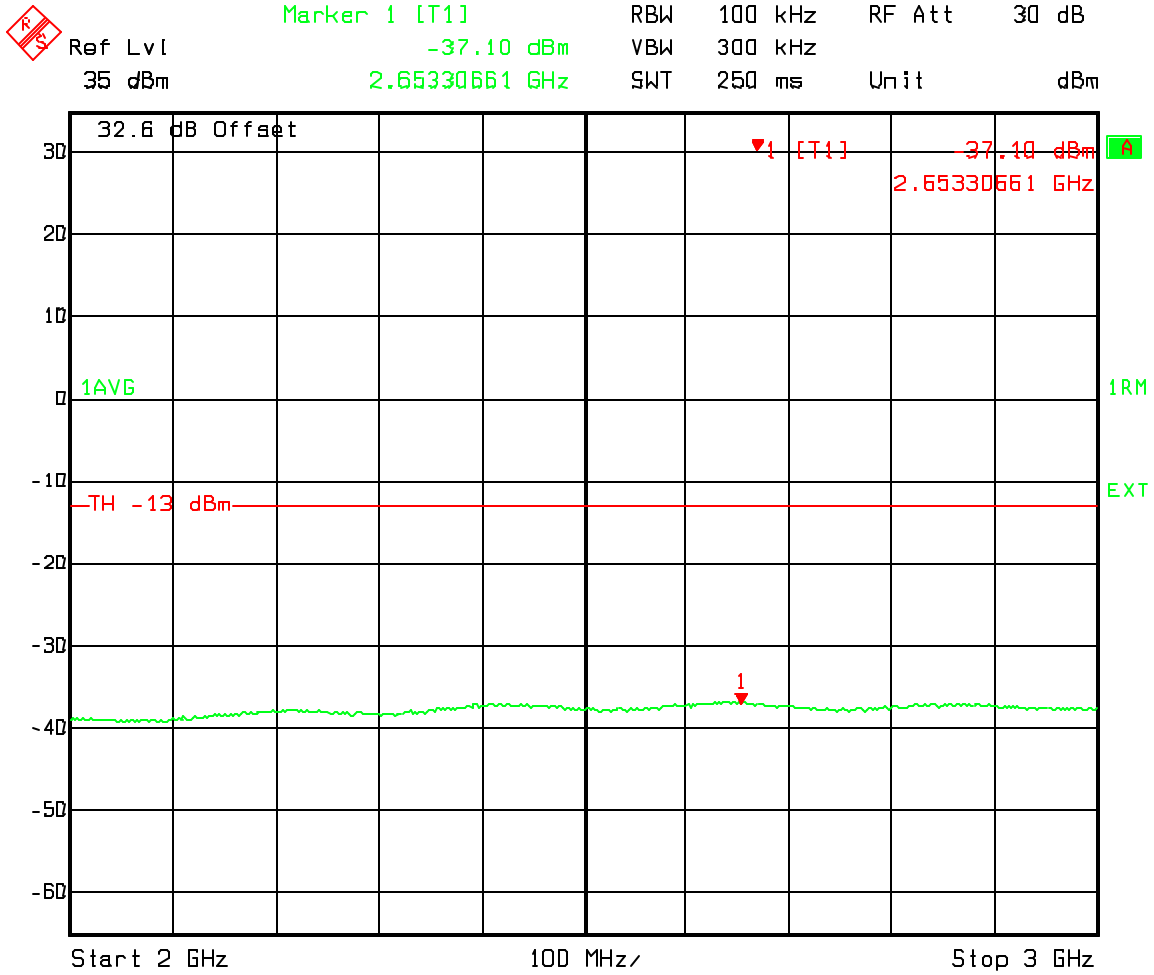

Date: 13.JAN.2004 21:23:20

Three Carrier Channel 1015, 33, 74 and 226, 267, 308 Spurious Emissions at the 800 MHz MFRM2 Ant. Port band A and A'' IS95

A'' and A Band IS95 Spurious emissions 3000-4000 MHz

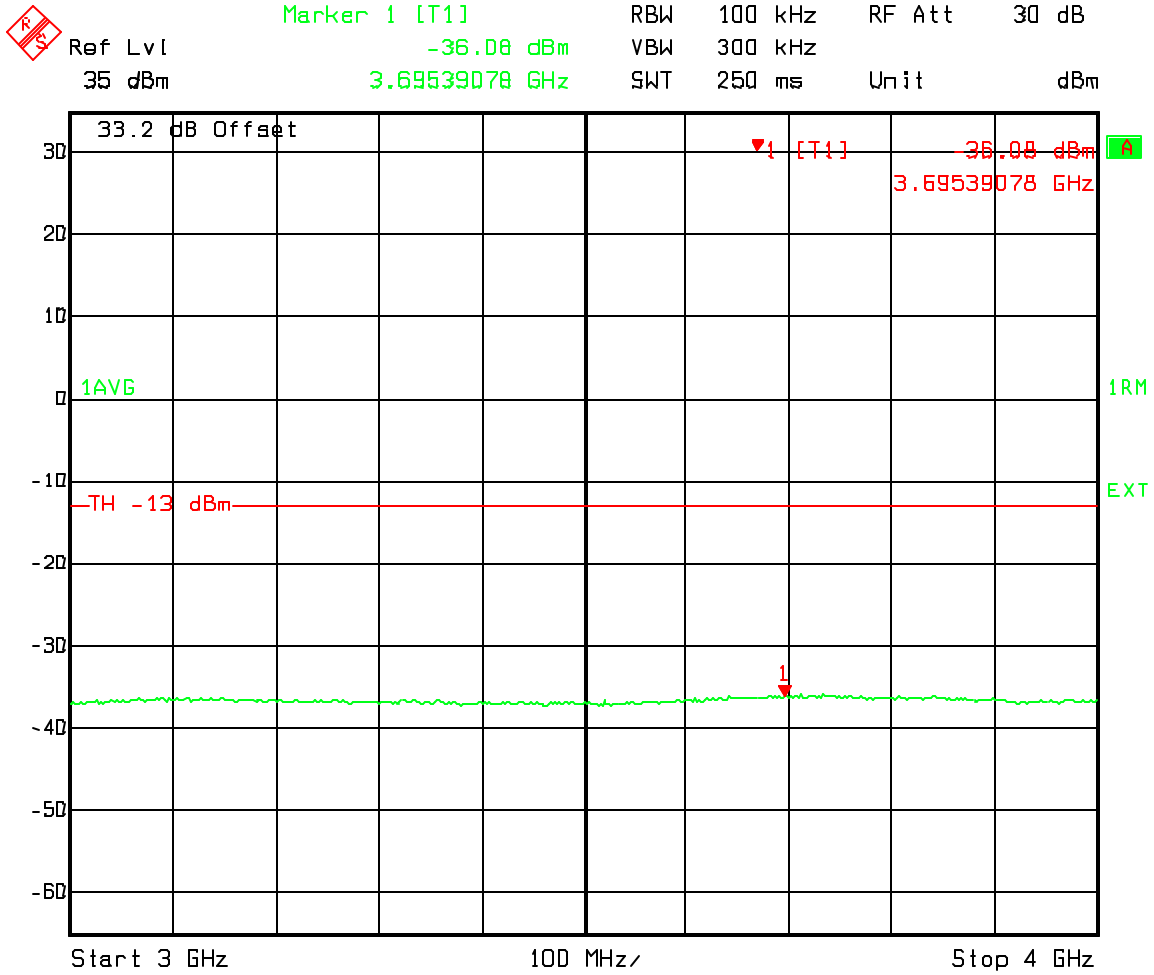

Date: 13.JAN.2004 21:24:09

Three Carrier Channel 1015, 33, 74 and 226, 267, 308 Spurious Emissions at the 800 MHz MFRM2 Ant. Port band A and A'' IS95

A'' and A Band IS95 Spurious emissions 4000-5000 MHz

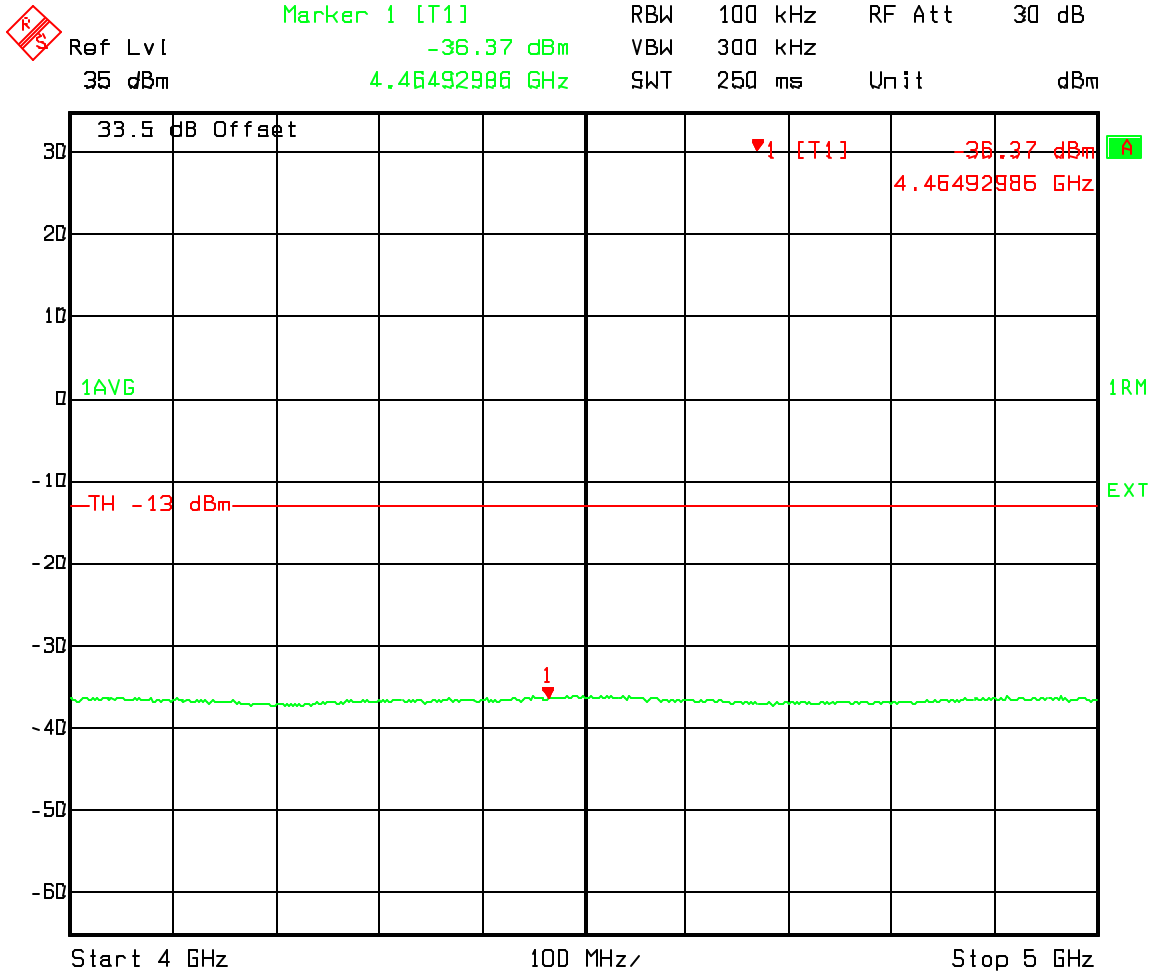

Date: 13.JAN.2004 21:24:59

Three Carrier Channel 1015, 33, 74 and 226, 267, 308 Spurious Emissions at the 800 MHz MFRM2 Ant. Port band A and A'' IS95

A'' and A Band IS95 Spurious emissions 5000-6000 MHz

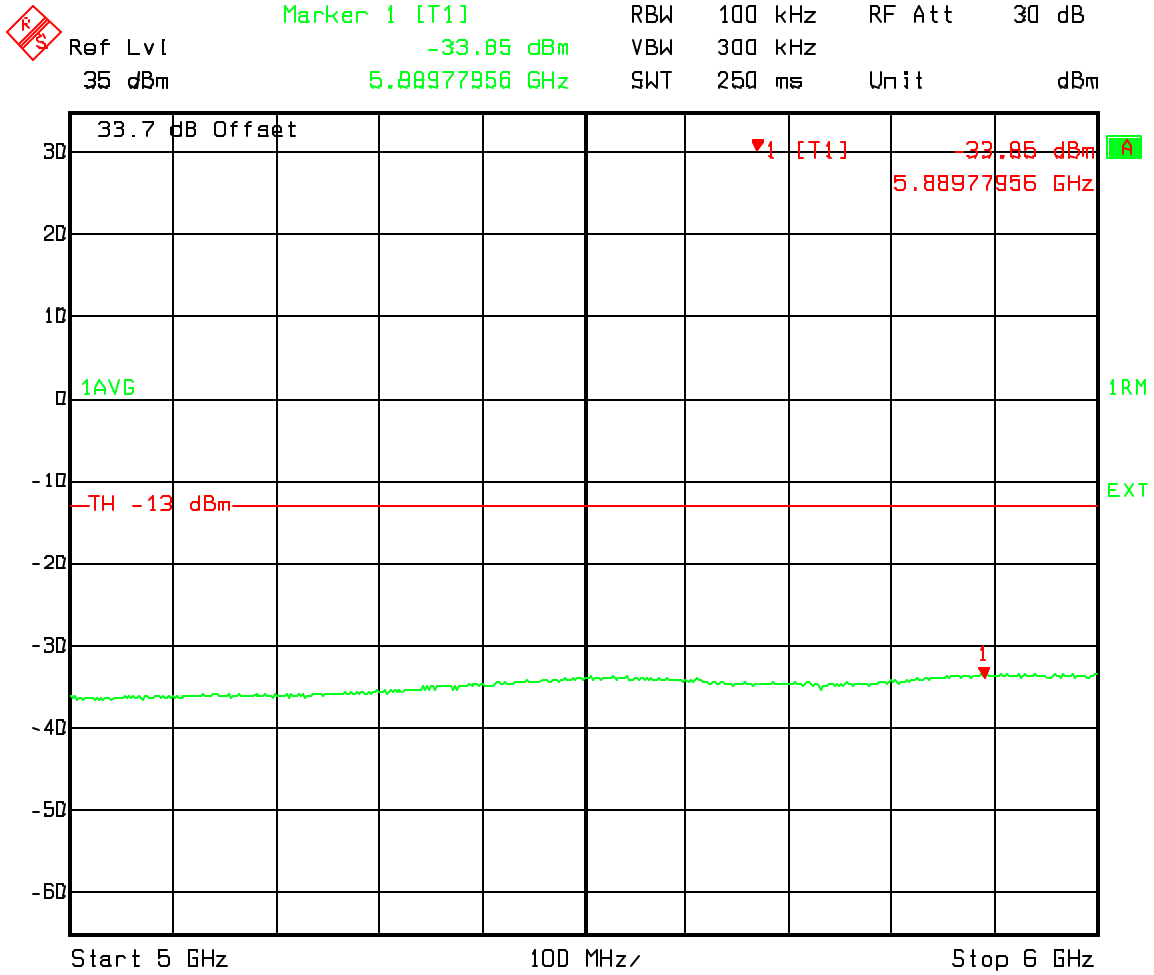

Date: 13.JAN.2004 21:25:49

Three Carrier Channel 1015, 33, 74 and 226, 267, 308 Spurious Emissions at the 800 MHz MFRM2 Ant. Port band A and A'' IS95

A'' and A Band IS95 Spurious emissions 6000-7000 MHz

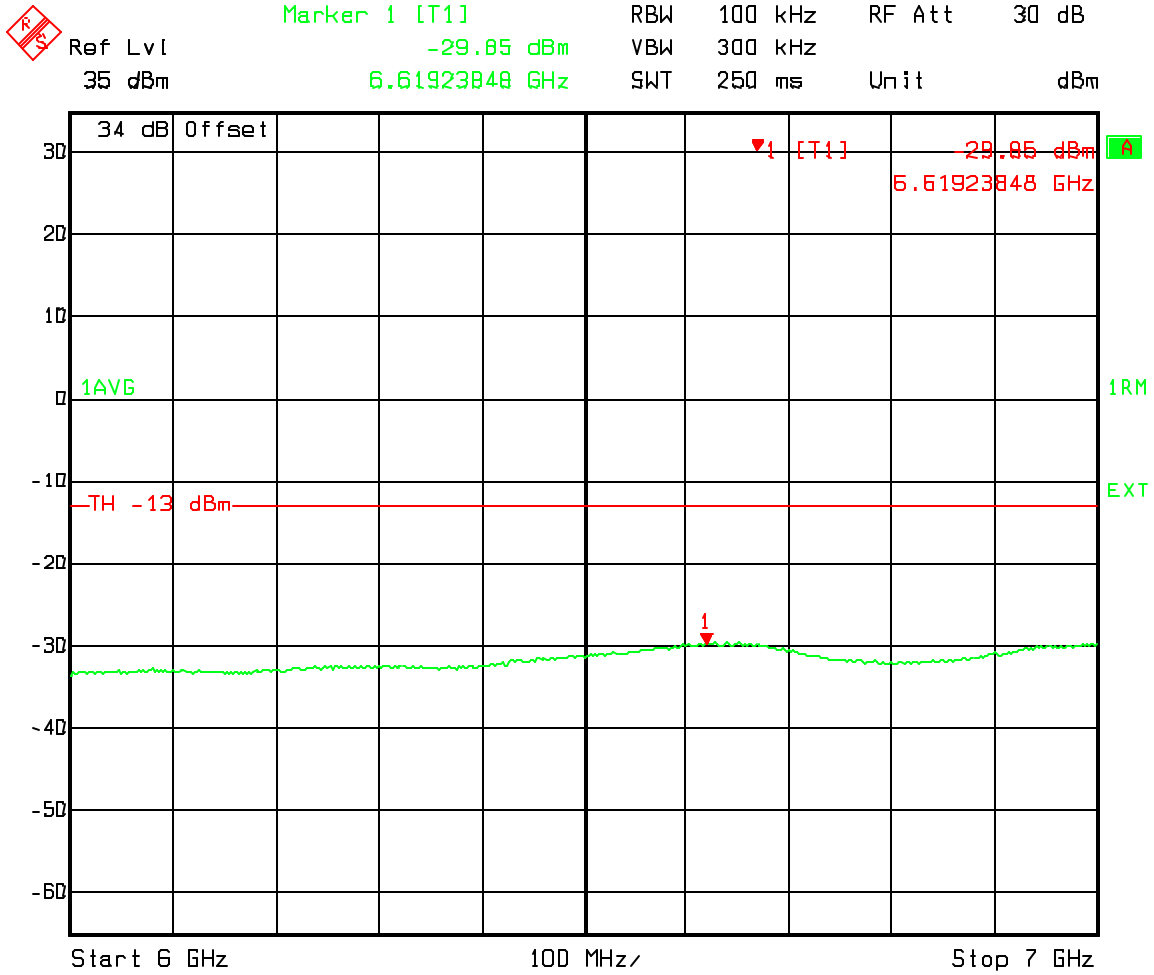

Date: 13.JAN.2004 21:26:41

Three Carrier Channel 1015, 33, 74 and 226, 267, 308 Spurious Emissions at the 800 MHz MFRM2 Ant. Port band A and A'' IS95

A'' and A Band IS95 Spurious emissions 7000-8000 MHz

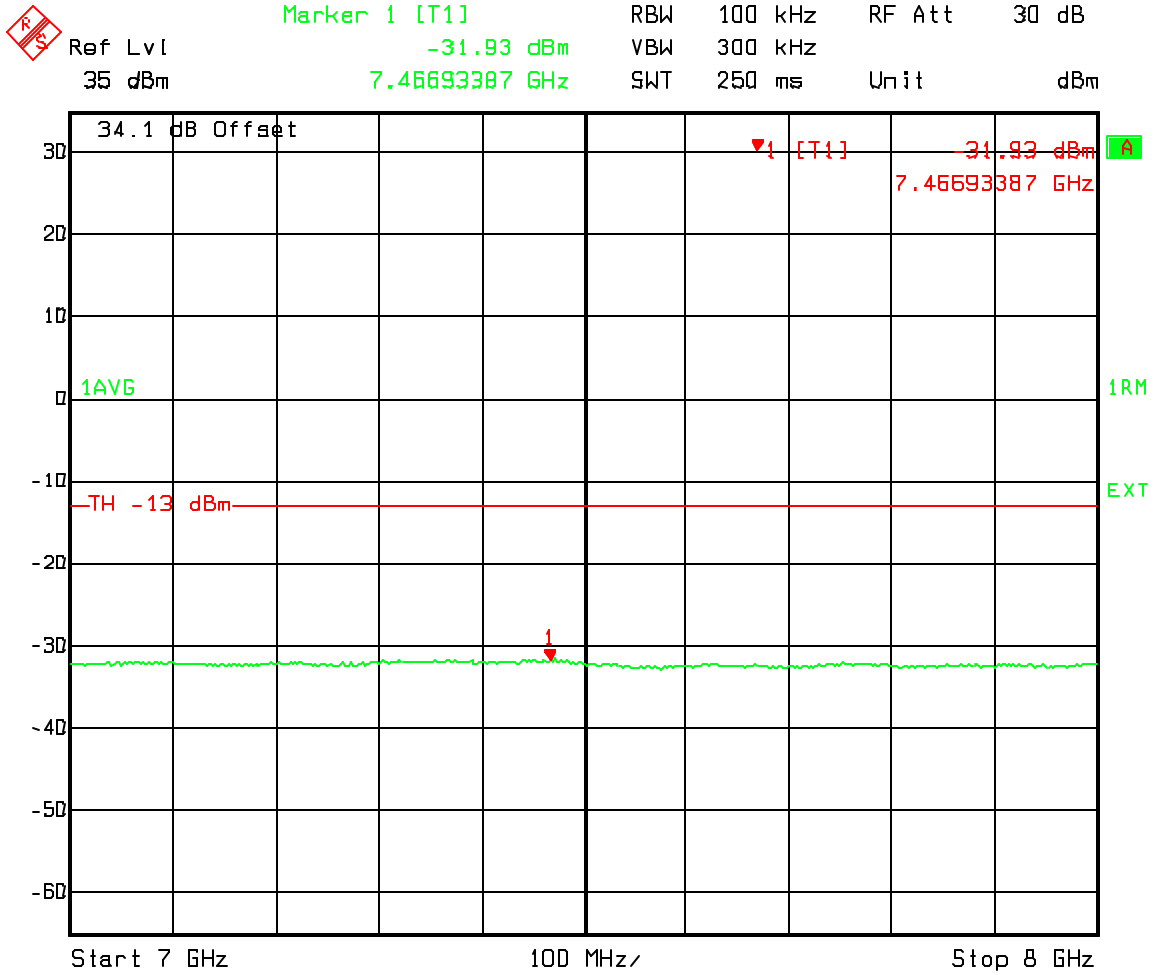

Date: 13.JAN.2004 21:27:35

Three Carrier Channel 1015, 33, 74 and 226, 267, 308 Spurious Emissions at the 800 MHz MFRM2 Ant. Port band A and A'' IS95

A'' and A Band IS95 Spurious emissions 8000-9000 MHz

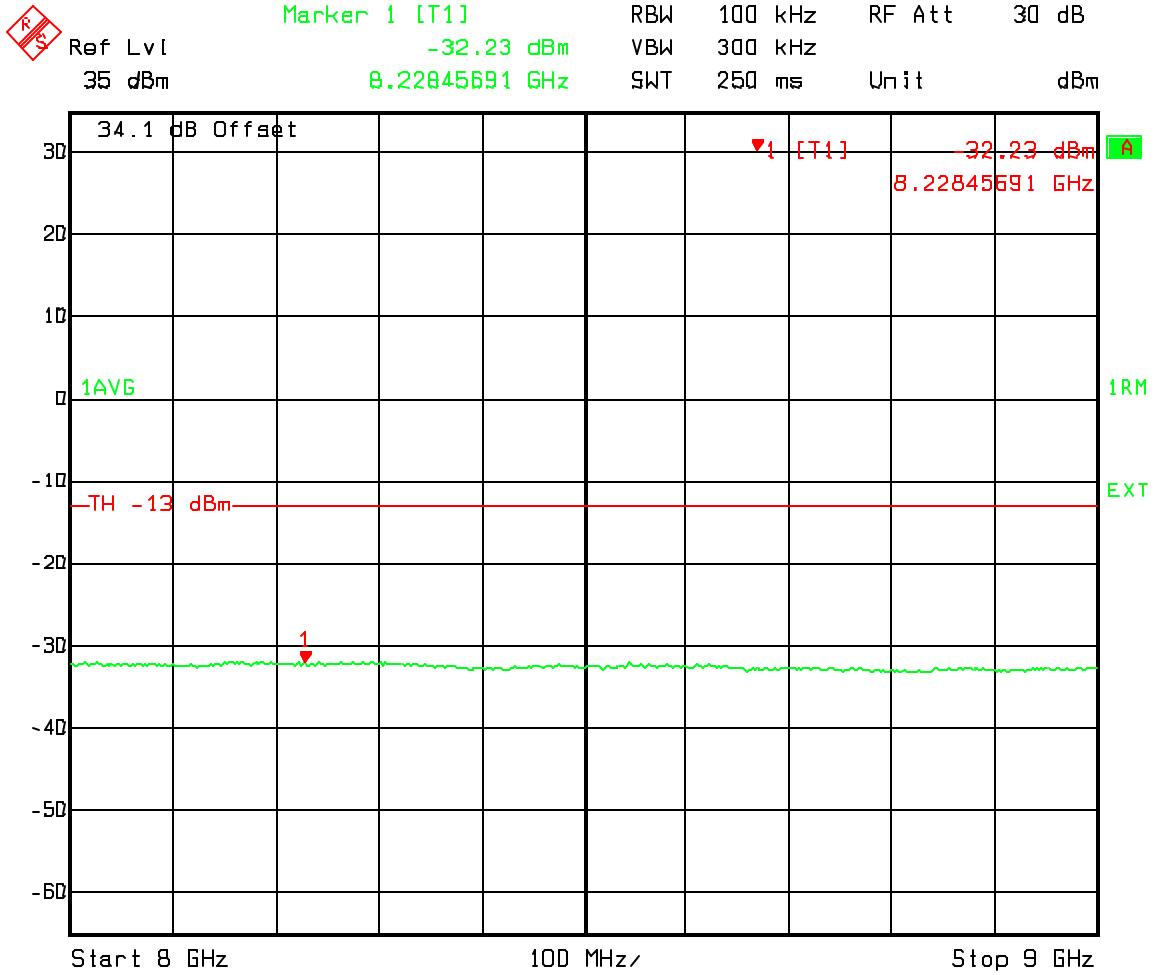

Date: 13.JAN.2004 21:28:27

Three Carrier Channel 1015, 33, 74 and 226, 267, 308 Spurious Emissions at the 800 MHz MFRM2 Ant. Port band A and A'' IS95

A'' and A Band IS95 Spurious emissions 9000-10000 MHz

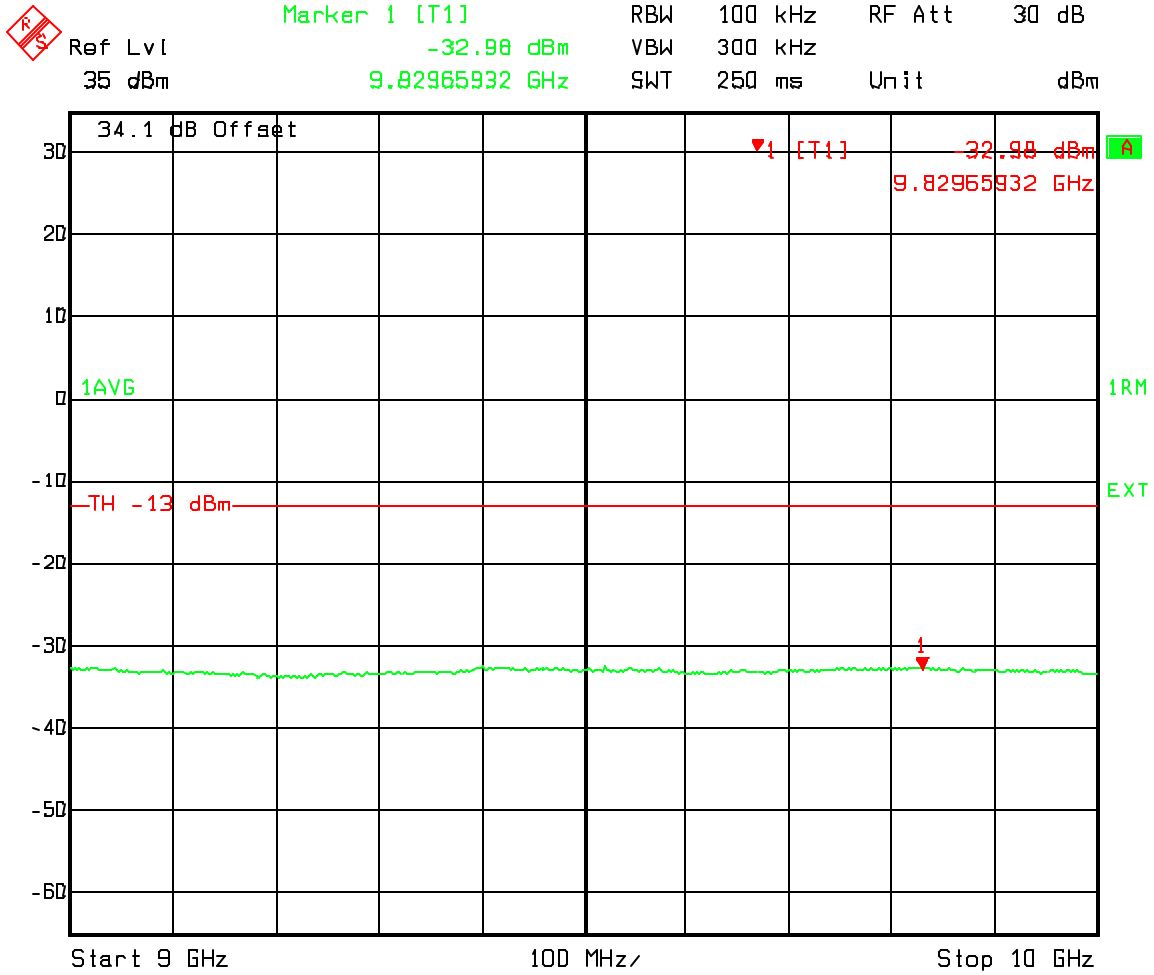

Date: 13.JAN.2004 21:29:19

**Single Chan 1015 and 308 Spurious Emissions at the 800 MHz MFRM2 Ant. Port
one Carrier band A and A'' IS 856**

Occupied Bandwidth Ch 1015 A''

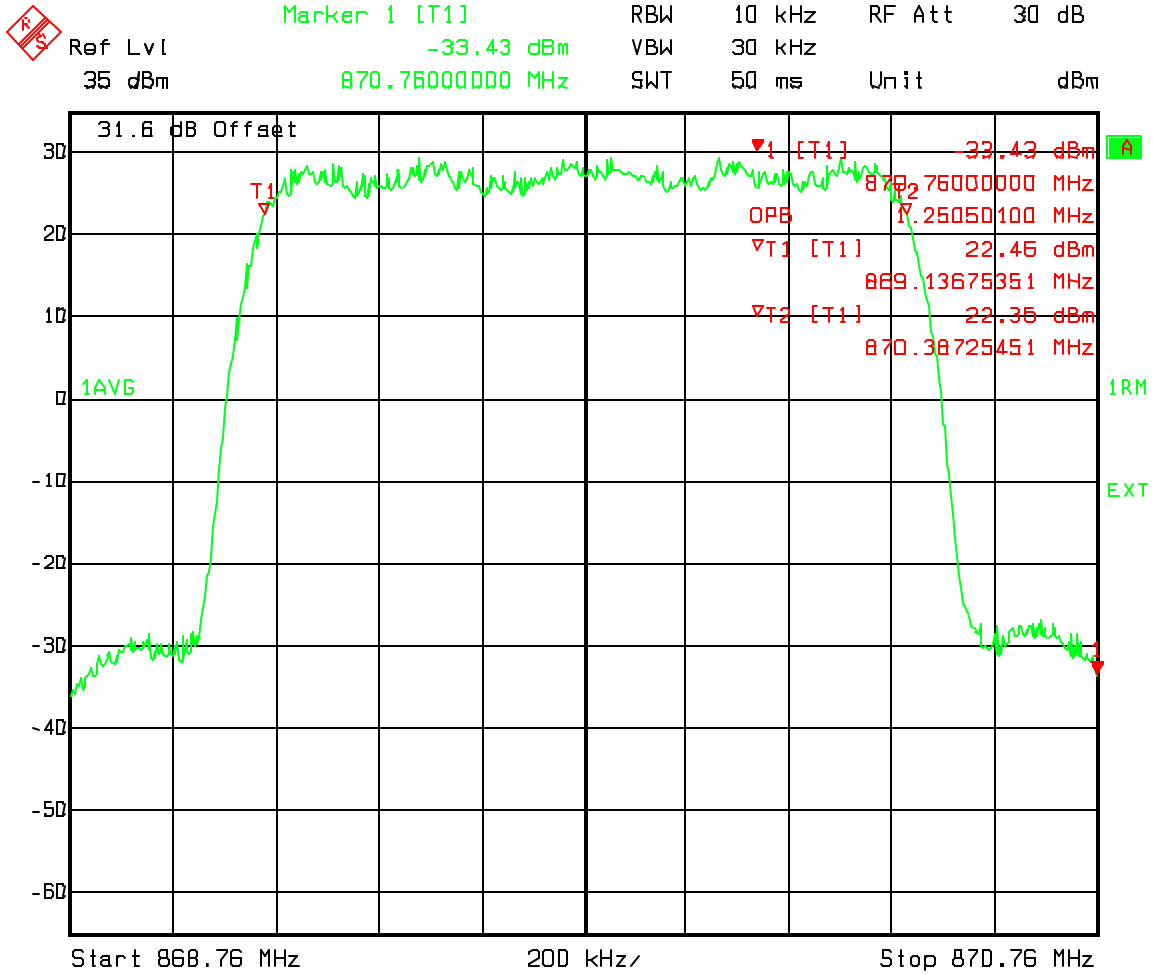

Date: 21.JAN.2004 2:38:47

Single Chan 1015 and 308 Spurious Emissions at the 800 MHz MFRM2 Ant. Port one Carrier band A and A'' IS 856

A'' Band Ch 1015 IS856 Adjacent 1Mhz Lower emissions 868-869MHz

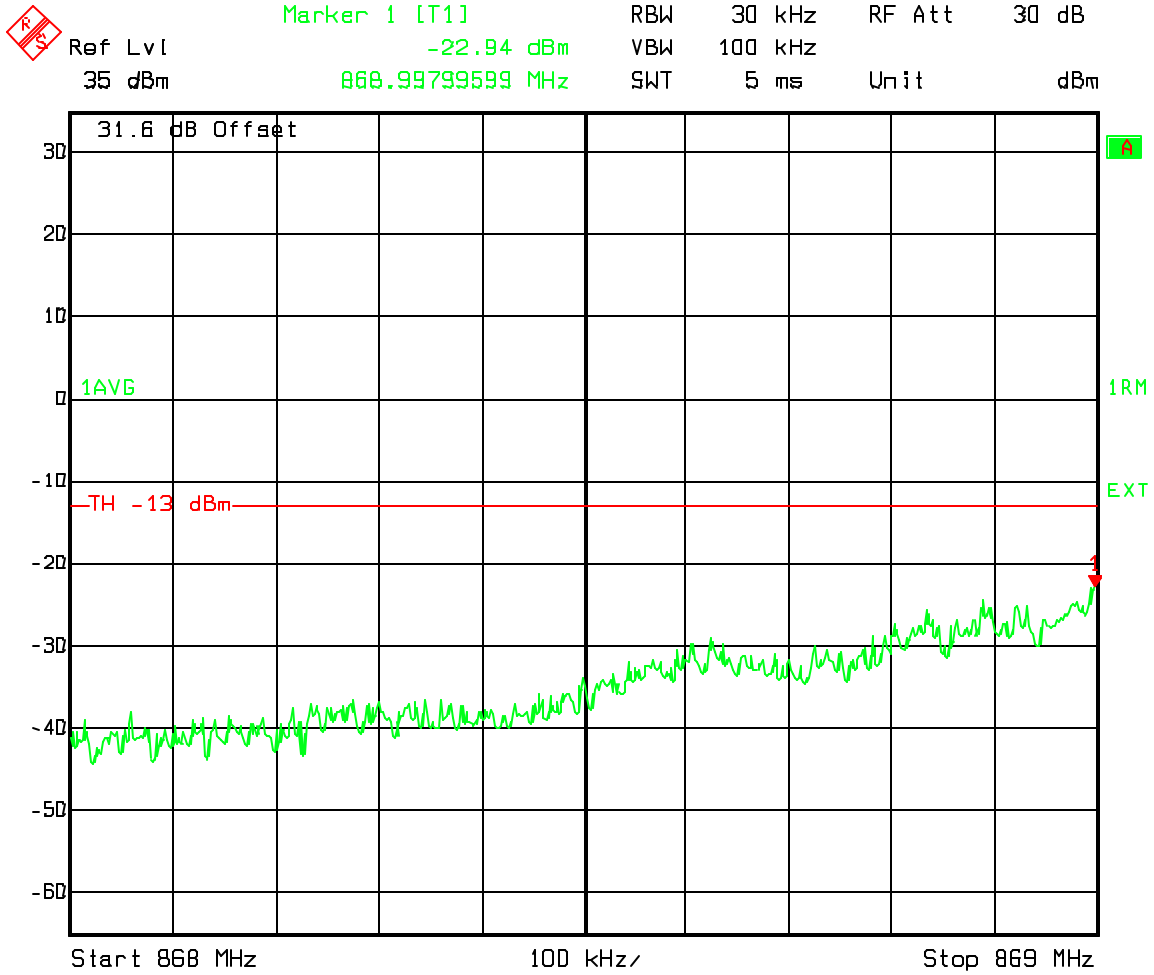

Date: 21.JAN.2004 2:16:27

**Single Chan 1015 and 308 Spurious Emissions at the 800 MHz MFRM2 Ant. Port
one Carrier band A and A'' IS 856**

A'' Band Ch1015 IS856 Adjacent 30kHz Lower emissions to 869 MHz

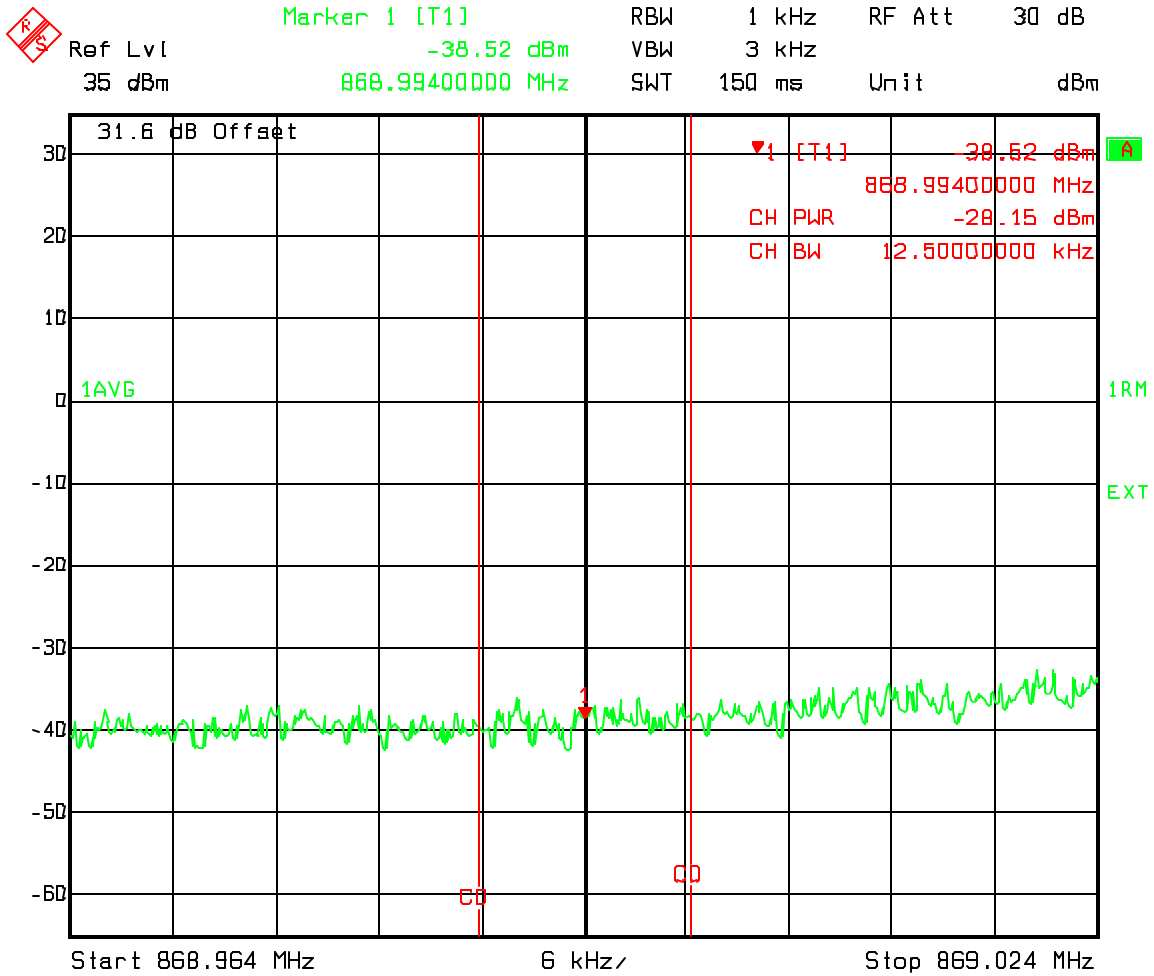

Date: 21.JAN.2004 2:17:18

Single Chan 1015 and 308 Spurious Emissions at the 800 MHz MFRM2 Ant. Port one Carrier band A and A'' IS 856

Ch 308 Upper A Band adjacent 1MHz band emissions

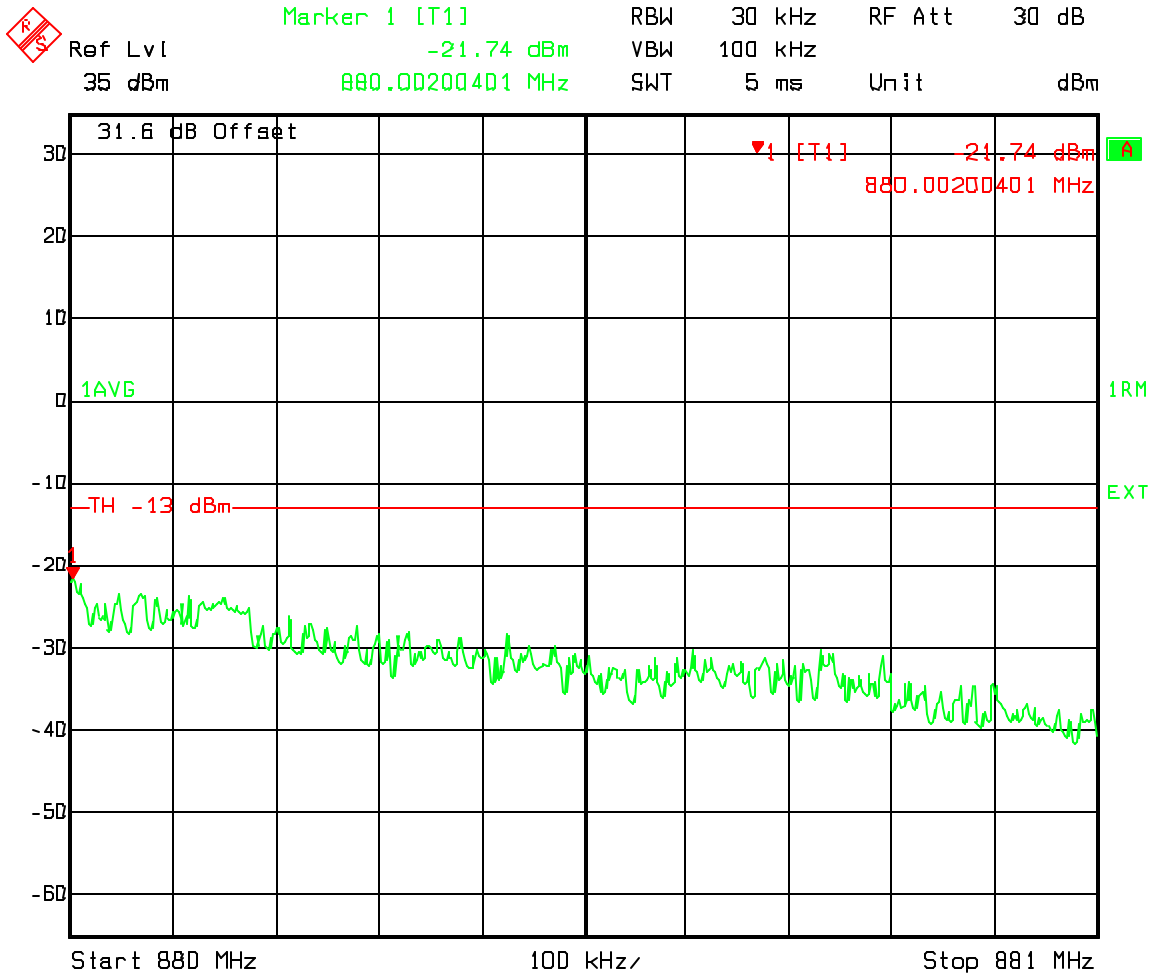

Date: 21.JAN.2004 17:52:41

**Single Chan 1015 and 308 Spurious Emissions at the 800 MHz MFRM2 Ant. Port
one Carrier band A and A'' IS 856**

Ch 308 Upper A Band adjacent to outside edge 12.5 kHz band Channel power

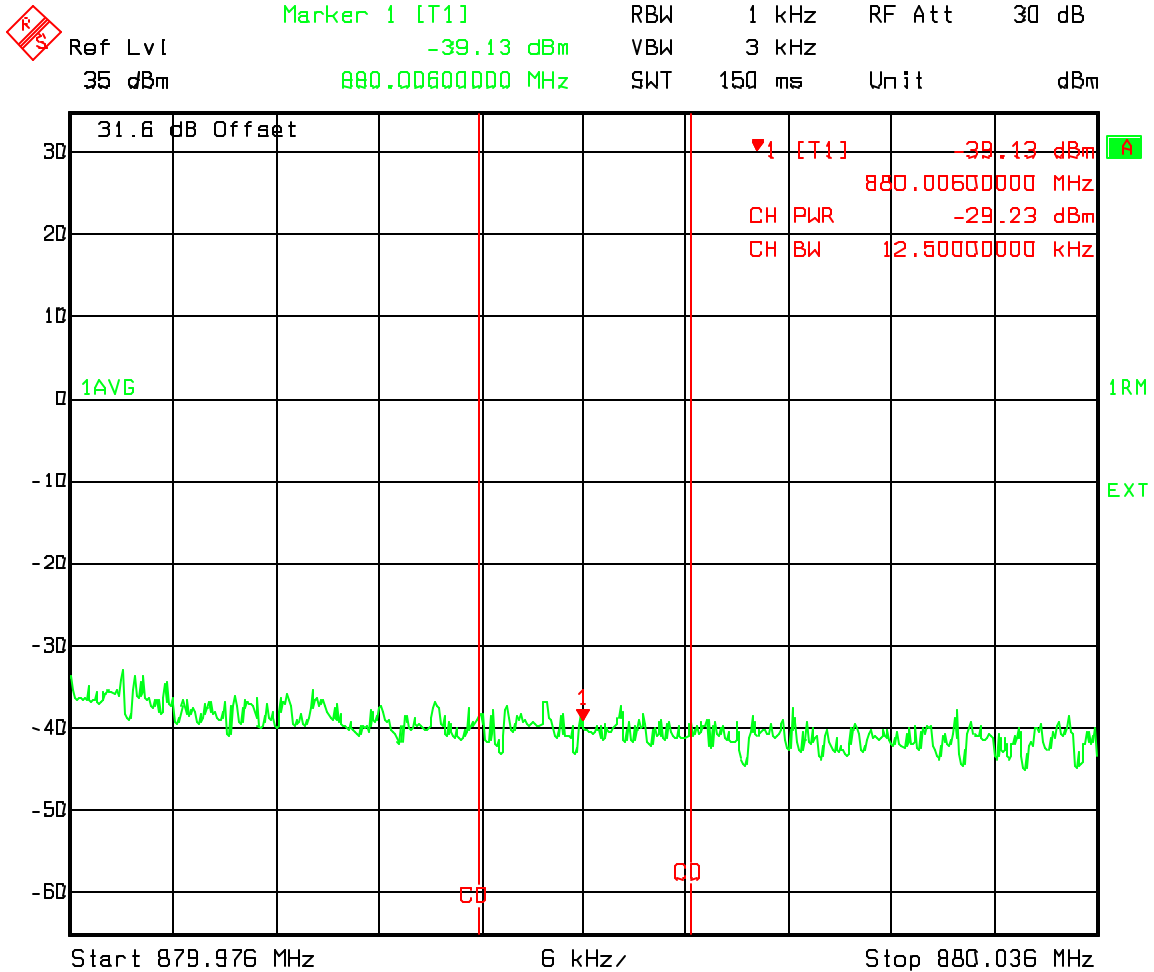

Date: 21.JAN.2004 17:53:35

**Single Chan 1015 and 308 Spurious Emissions at the 800 MHz MFRM2 Ant. Port
one Carrier band A and A'' IS 856**

Industry Canada Lower 750 kHz offset 30kHz Chan Power Ch 1015

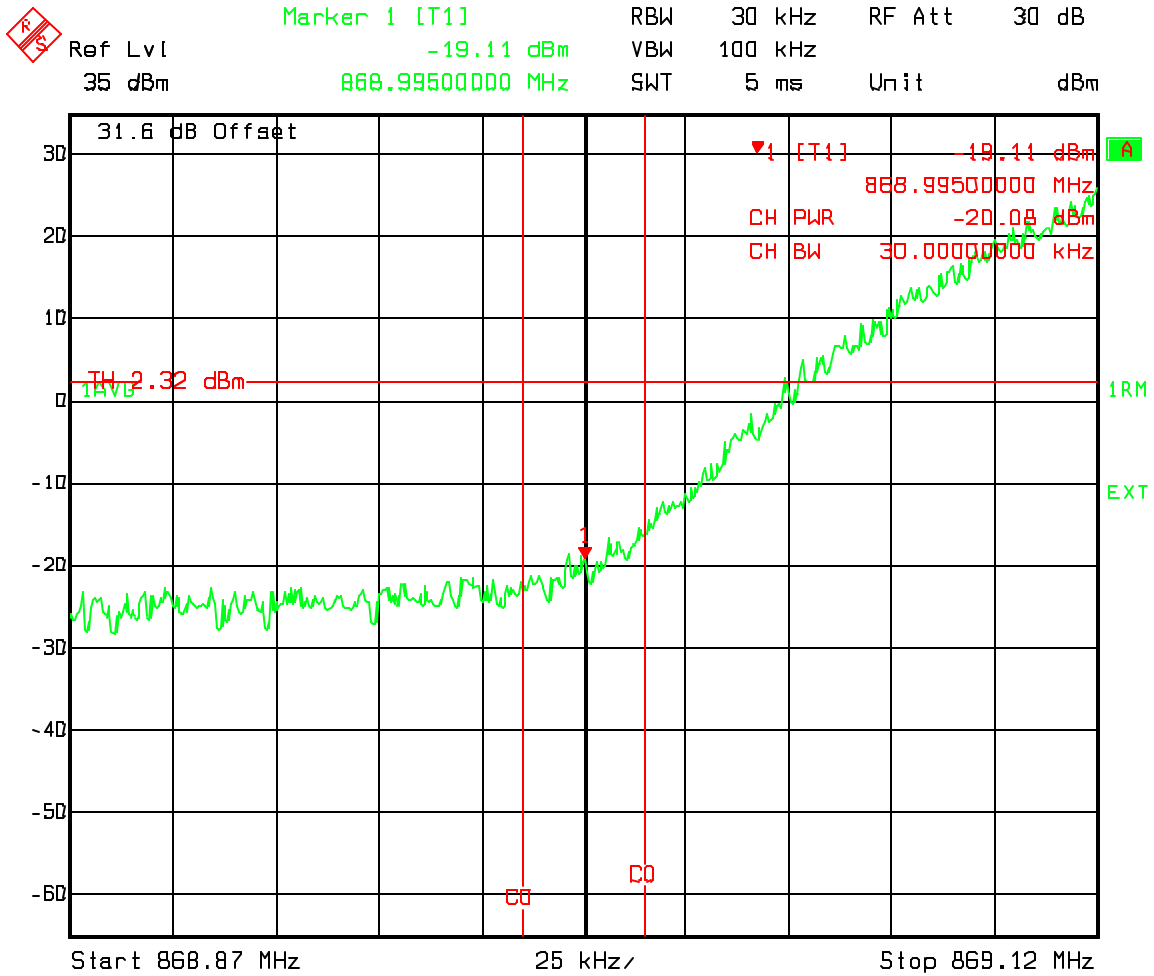

Date: 21.JAN.2004 2:40:34

**Single Chan 1015 and 308 Spurious Emissions at the 800 MHz MFRM2 Ant. Port
one Carrier band A and A'' IS 856**

Industry Canada Upper 750 kHz offset 30kHz Chan Power Ch 1015

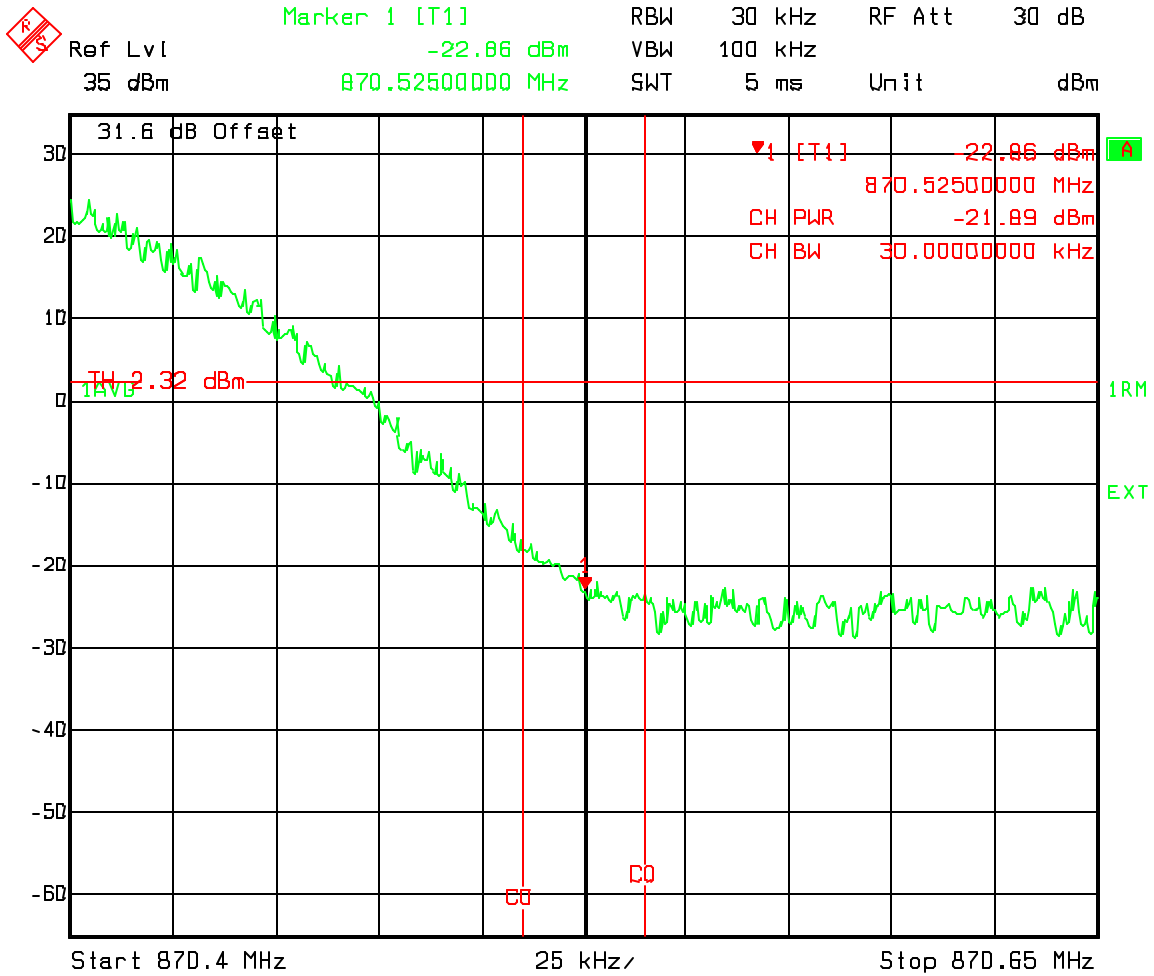

Date: 21.JAN.2004 2:41:27

**Single Chan 1015 and 308 Spurious Emissions at the 800 MHz MFRM2 Ant. Port
one Carrier band A and A'' IS 856**

Industry Canada 1.98 MHz offset Lower 30kHz Chan Power Ch 1015

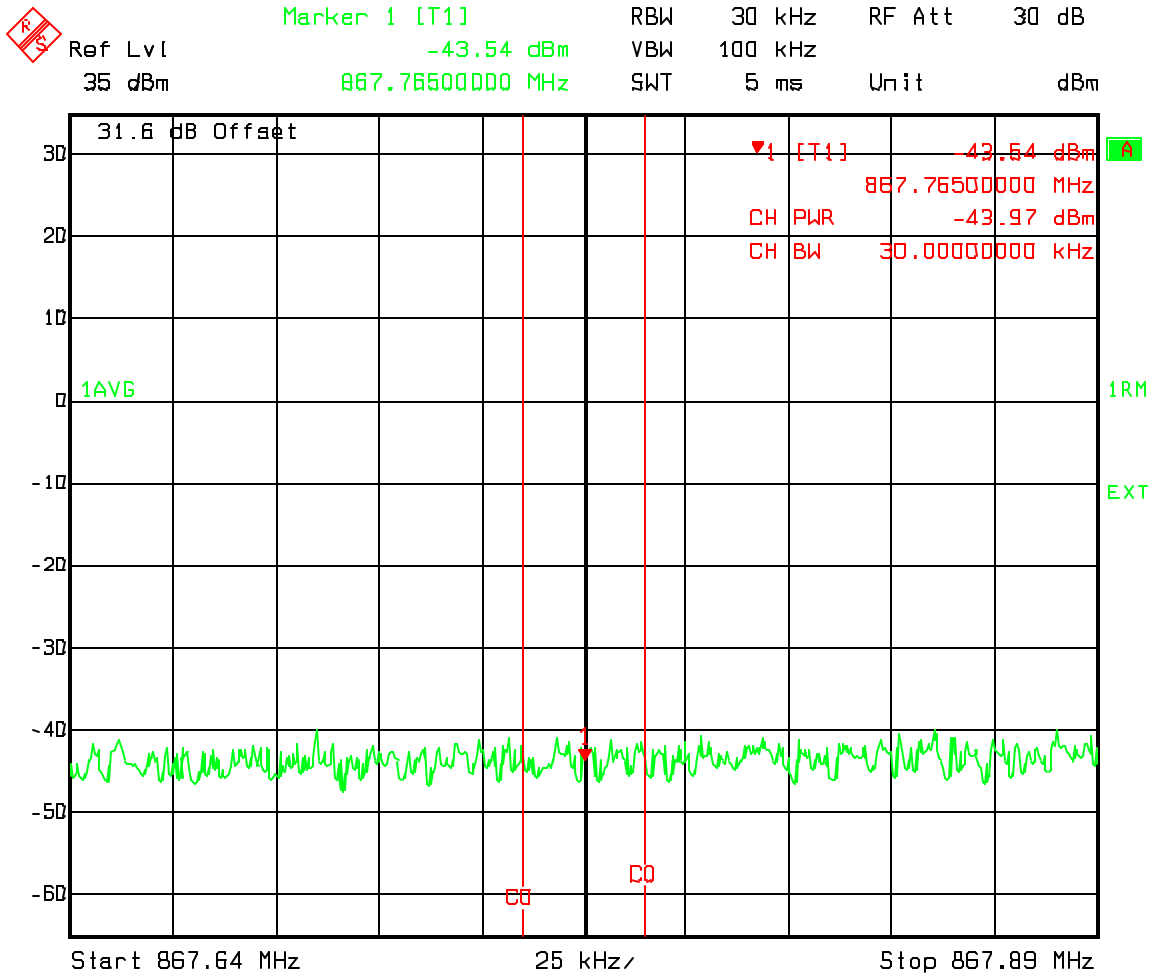

Date: 21.JAN.2004 2:42:20

**Single Chan 1015 and 308 Spurious Emissions at the 800 MHz MFRM2 Ant. Port
one Carrier band A and A'' IS 856**

Industry Canada 1.98 MHz offset Upper 30kHz Chan Power Ch 1015

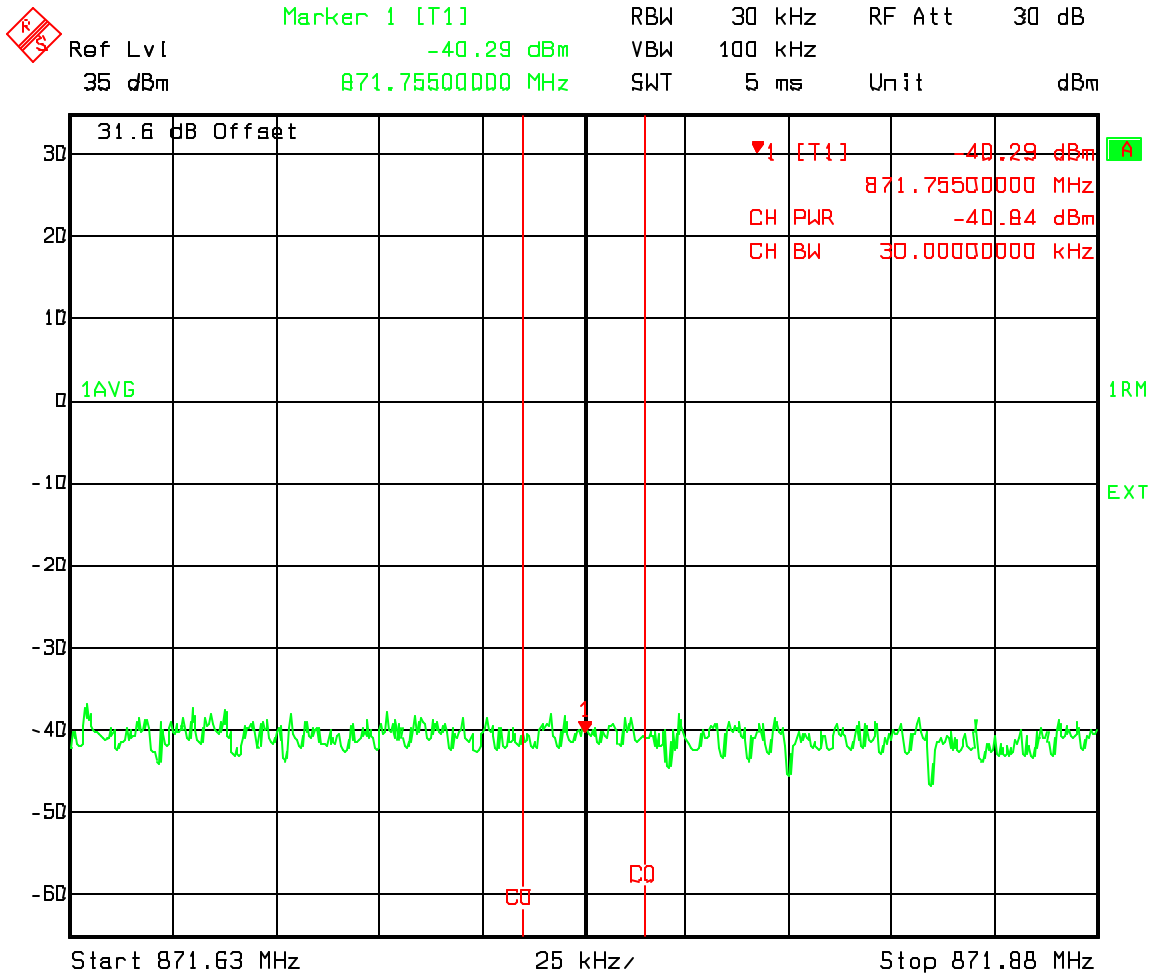

Date: 21.JAN.2004 2:43:15

**Single Chan 1015 and 308 Spurious Emissions at the 800 MHz MFRM2 Ant. Port
one Carrier band A and A'' IS 856**

A'' and A Band IS856 Spurious emissions 10kHz-400 MHz

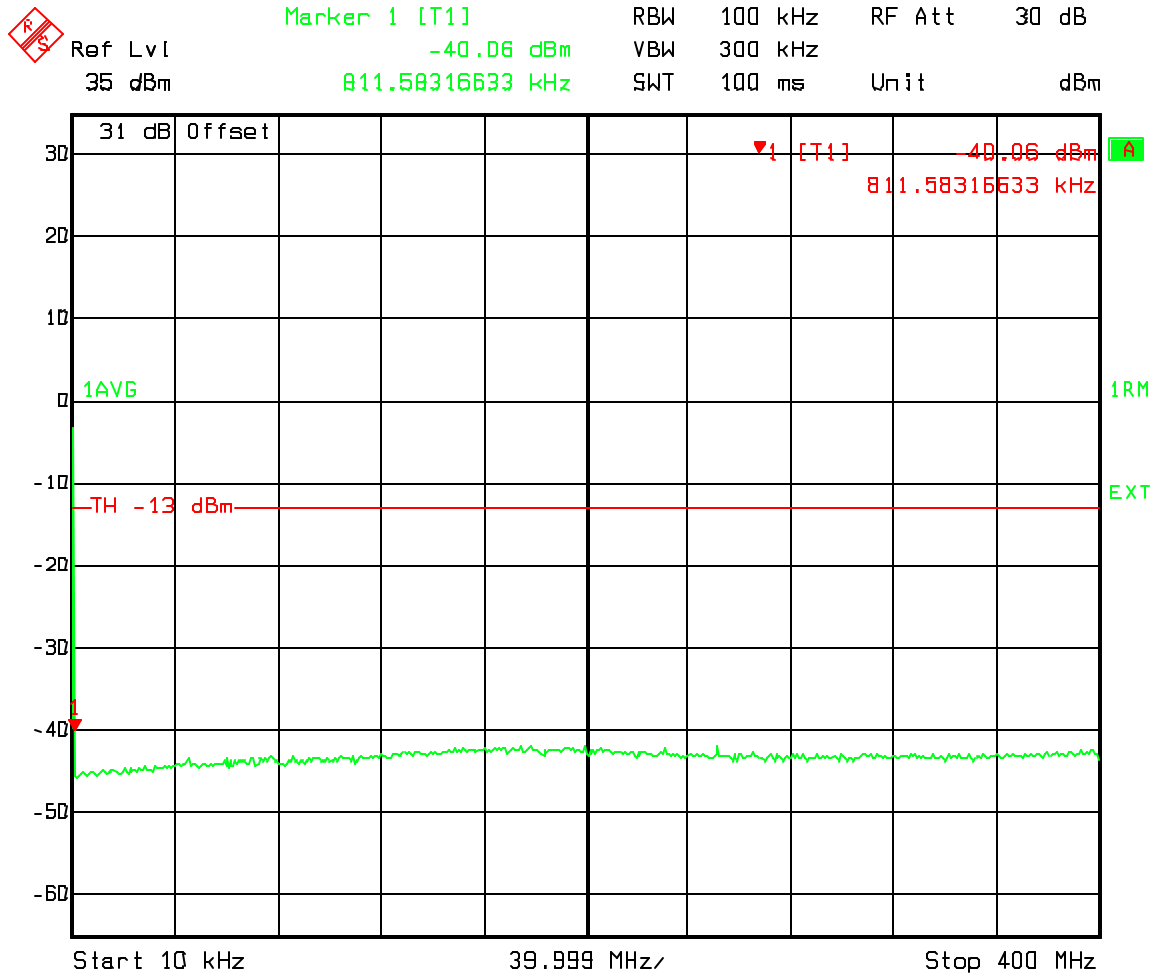

Date: 21 JAN 2004 2:19:59

**Single Chan 1015 and 308 Spurious Emissions at the 800 MHz MFRM2 Ant. Port
one Carrier band A and A'' IS 856**

A'' and A Band IS856 Spurious emissions 400MHz to Lower 1MHz Band Edge

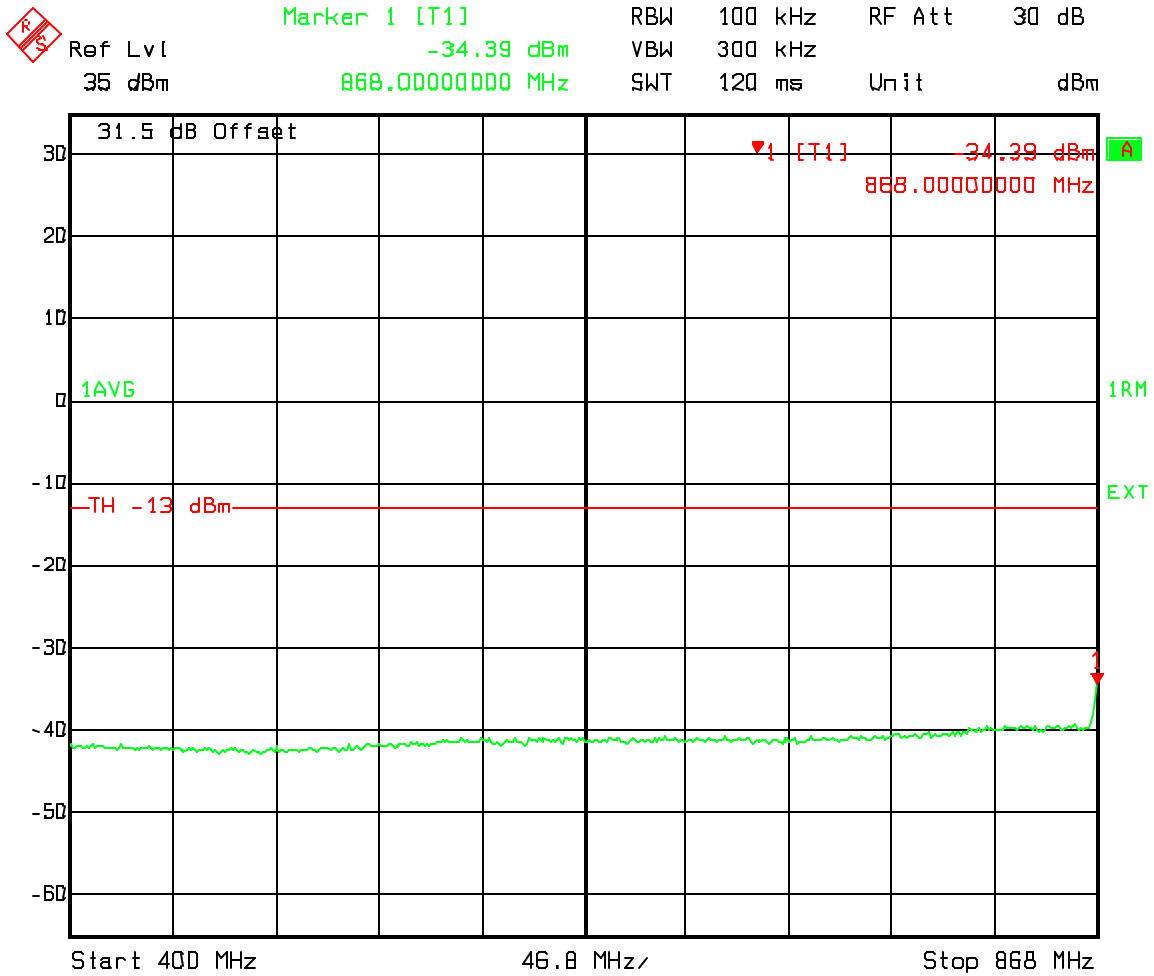

Date: 21.JAN.2004 2:29:51

Single Chan 1015 and 308 Spurious Emissions at the 800 MHz MFRM2 Ant. Port one Carrier band A and A'' IS 856

A'' and A Band IS856 Spurious emissions Upper 1MHz Band Edge to 1GHz

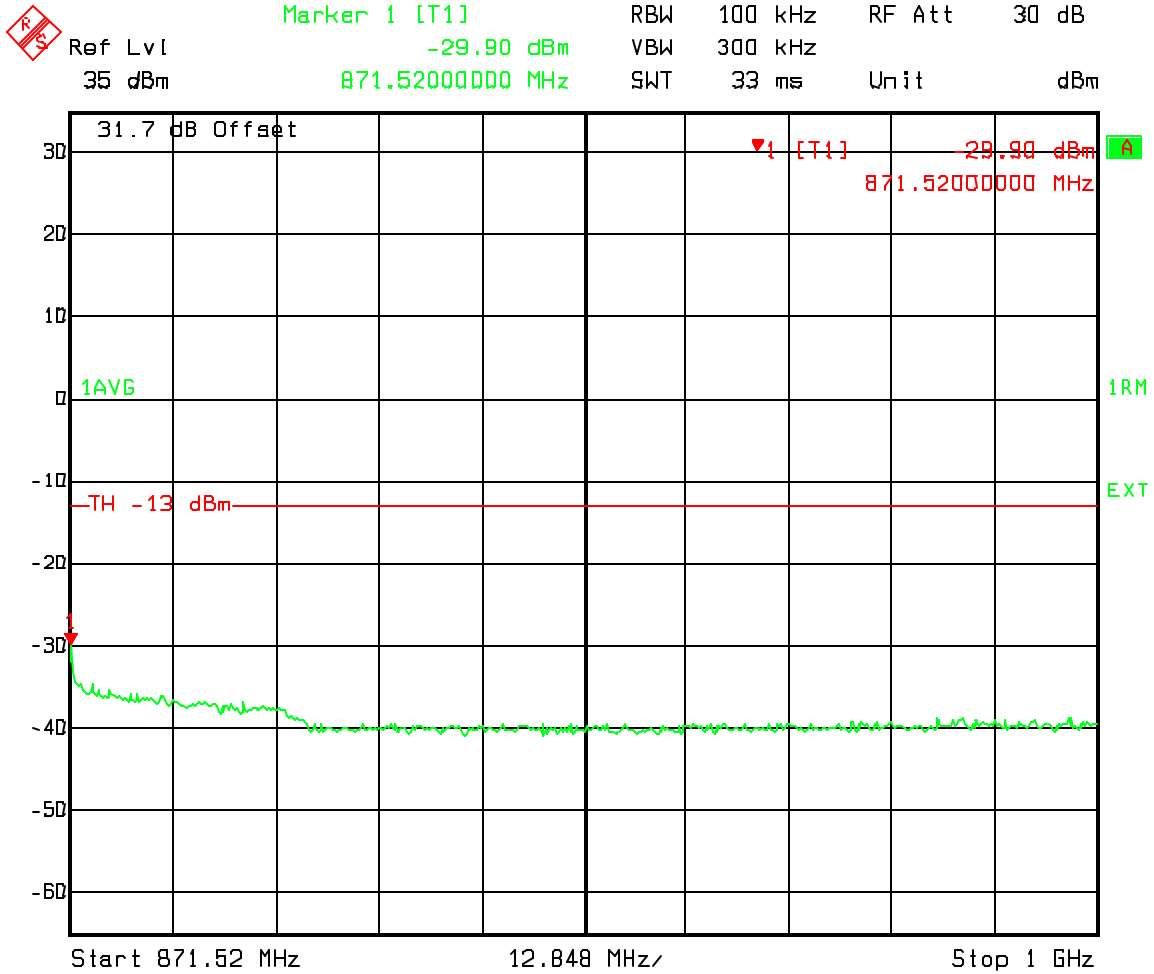

Date: 21.JAN.2004 2:30:47

Single Chan 1015 and 308 Spurious Emissions at the 800 MHz MFRM2 Ant. Port one Carrier band A and A'' IS 856

A'' and A Band IS856 Spurious emissions 400-1000 MHz

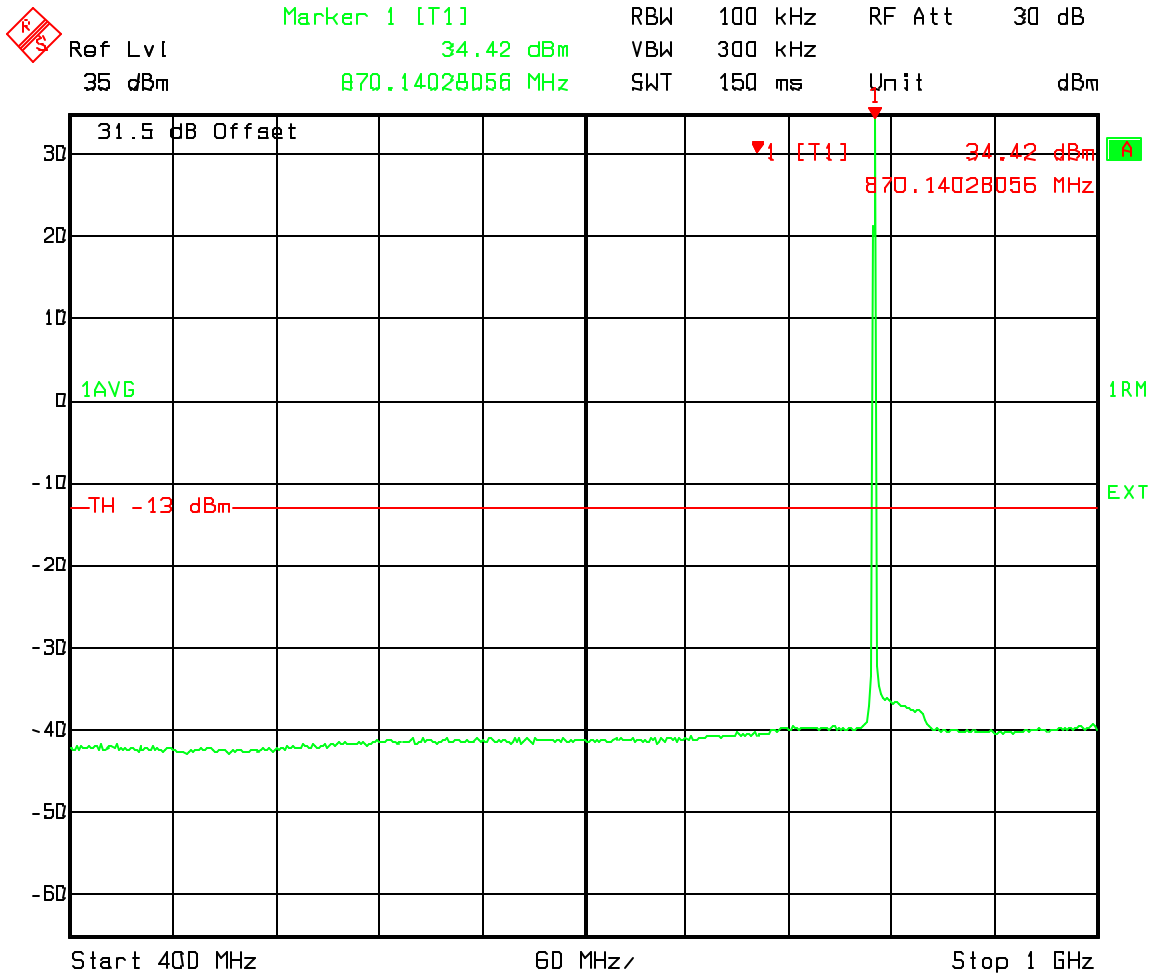

Date: 21.JAN.2004 2:20:54

Single Chan 1015 and 308 Spurious Emissions at the 800 MHz MFRM2 Ant. Port one Carrier band A and A'' IS 856

A'' and A Band IS856 Spurious emissions 1000-2000 MHz

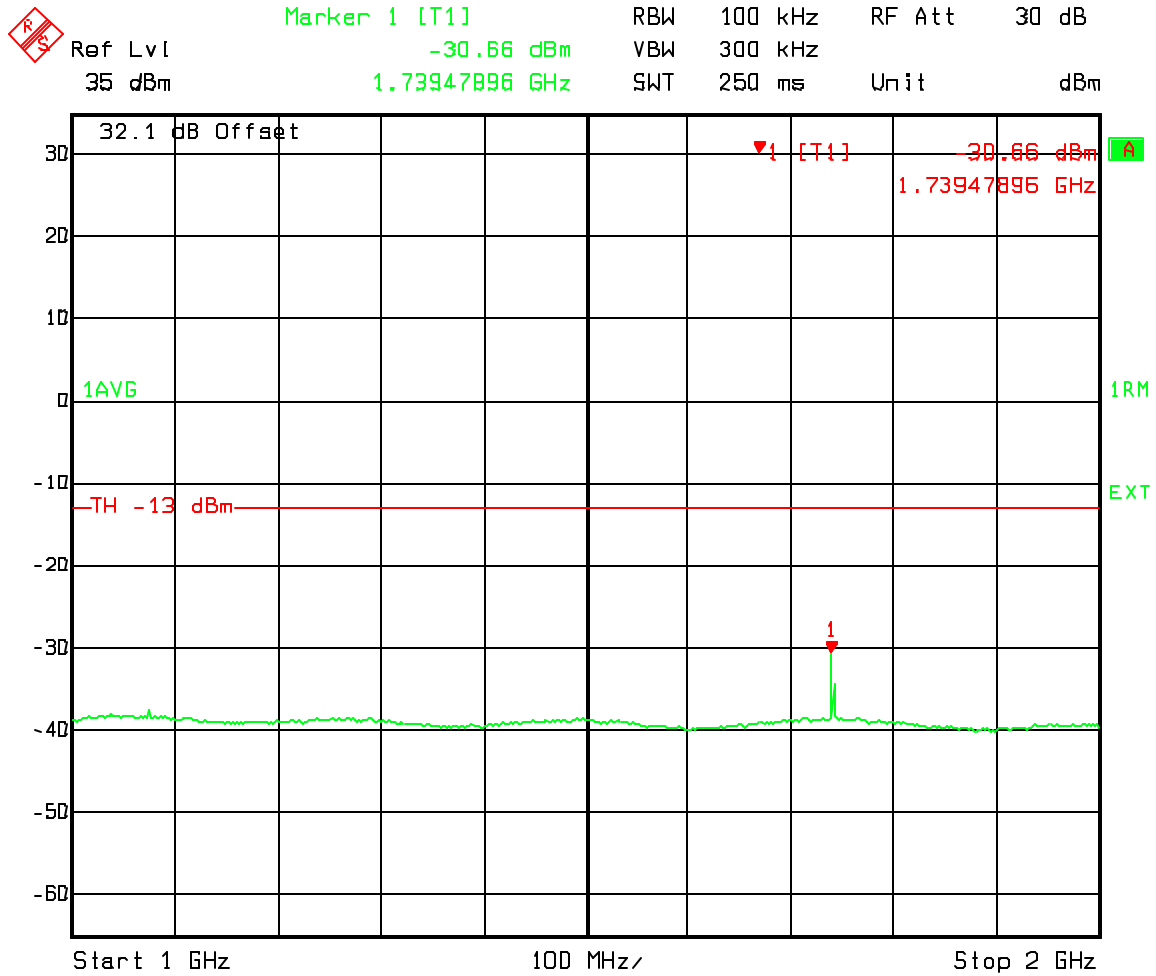

Date: 21.JAN.2004 2:21:46

Single Chan 1015 and 308 Spurious Emissions at the 800 MHz MFRM2 Ant. Port one Carrier band A and A'' IS 856

A'' and A Band IS856 Spurious emissions 2000-3000 MHz

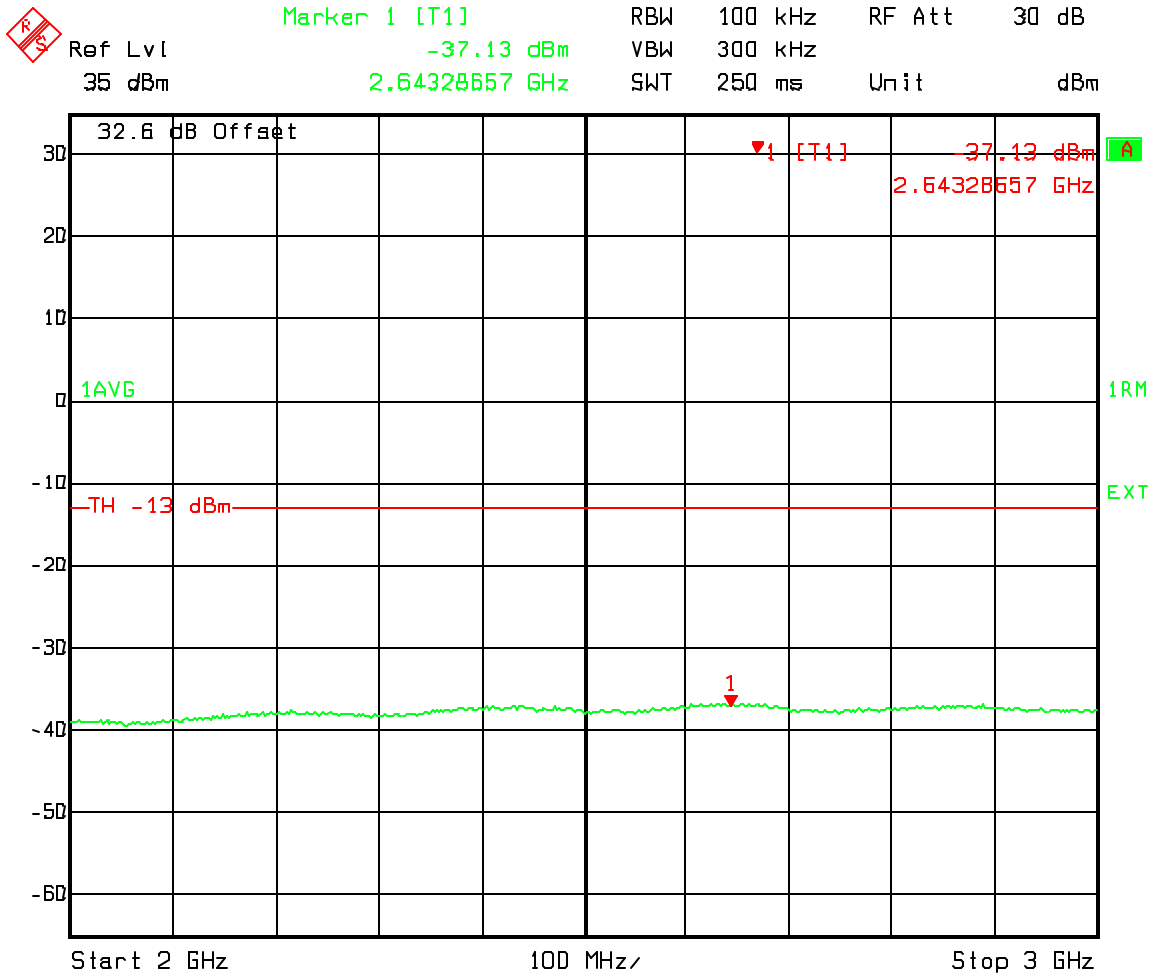

Date: 21.JAN.2004 2:22:39

**Single Chan 1015 and 308 Spurious Emissions at the 800 MHz MFRM2 Ant. Port
one Carrier band A and A'' IS 856**

A'' and A Band IS856 Spurious emissions 3000-4000 MHz

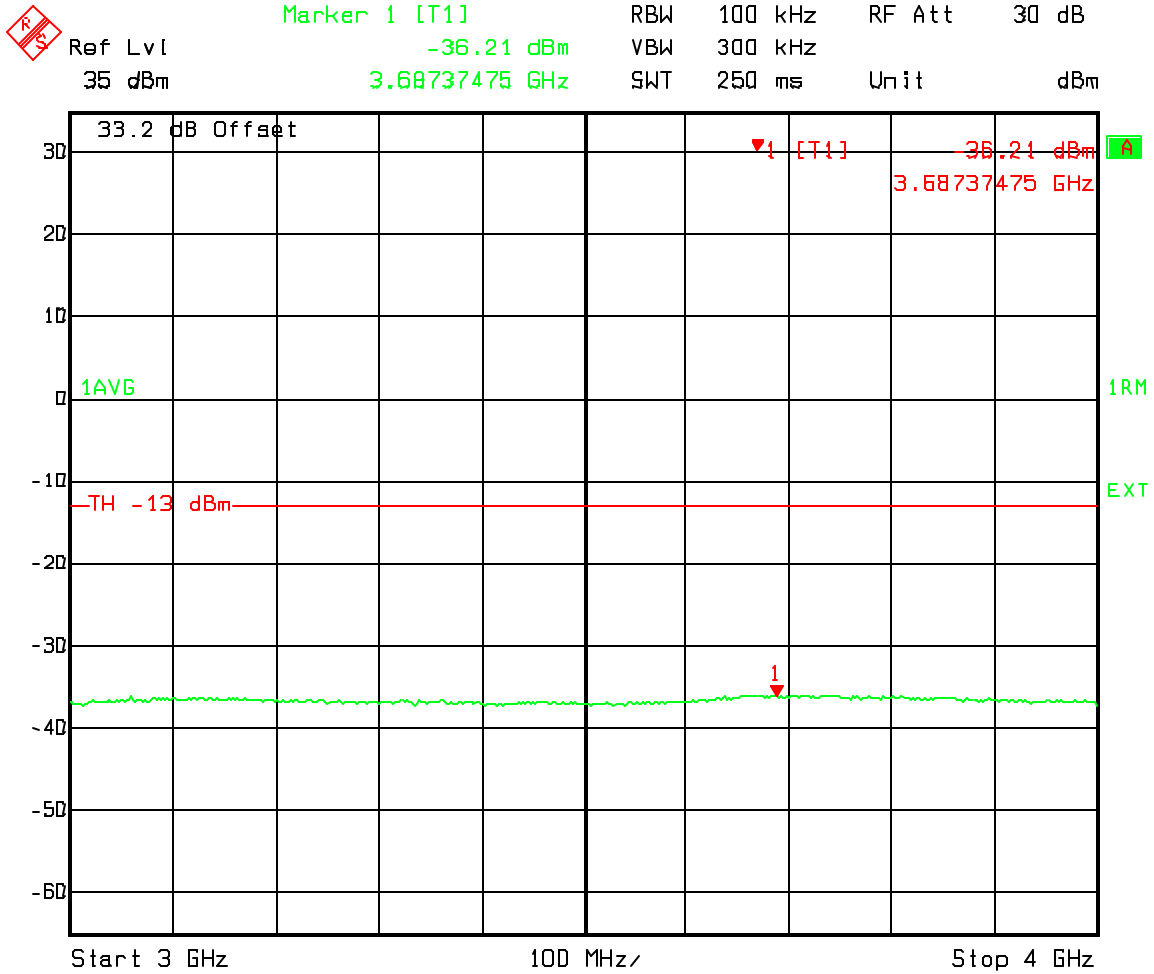

Date: 21.JAN.2004 2:23:30

**Single Chan 1015 and 308 Spurious Emissions at the 800 MHz MFRM2 Ant. Port
one Carrier band A and A'' IS 856**

A'' and A Band IS856 Spurious emissions 4000-5000 MHz

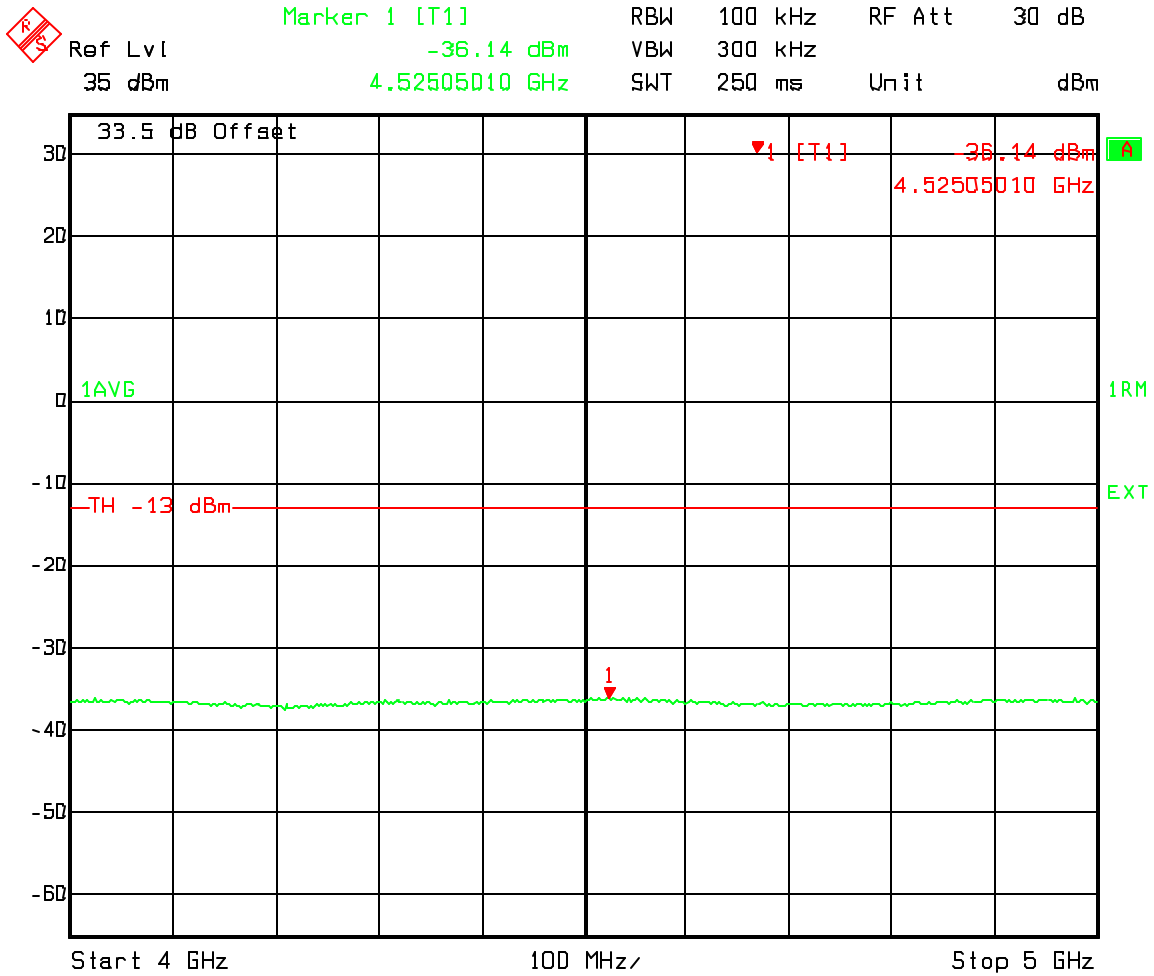

Date: 21.JAN.2004 2:24:25

Single Chan 1015 and 308 Spurious Emissions at the 800 MHz MFRM2 Ant. Port one Carrier band A and A'' IS 856

A'' and A Band IS856 Spurious emissions 5000-6000 MHz

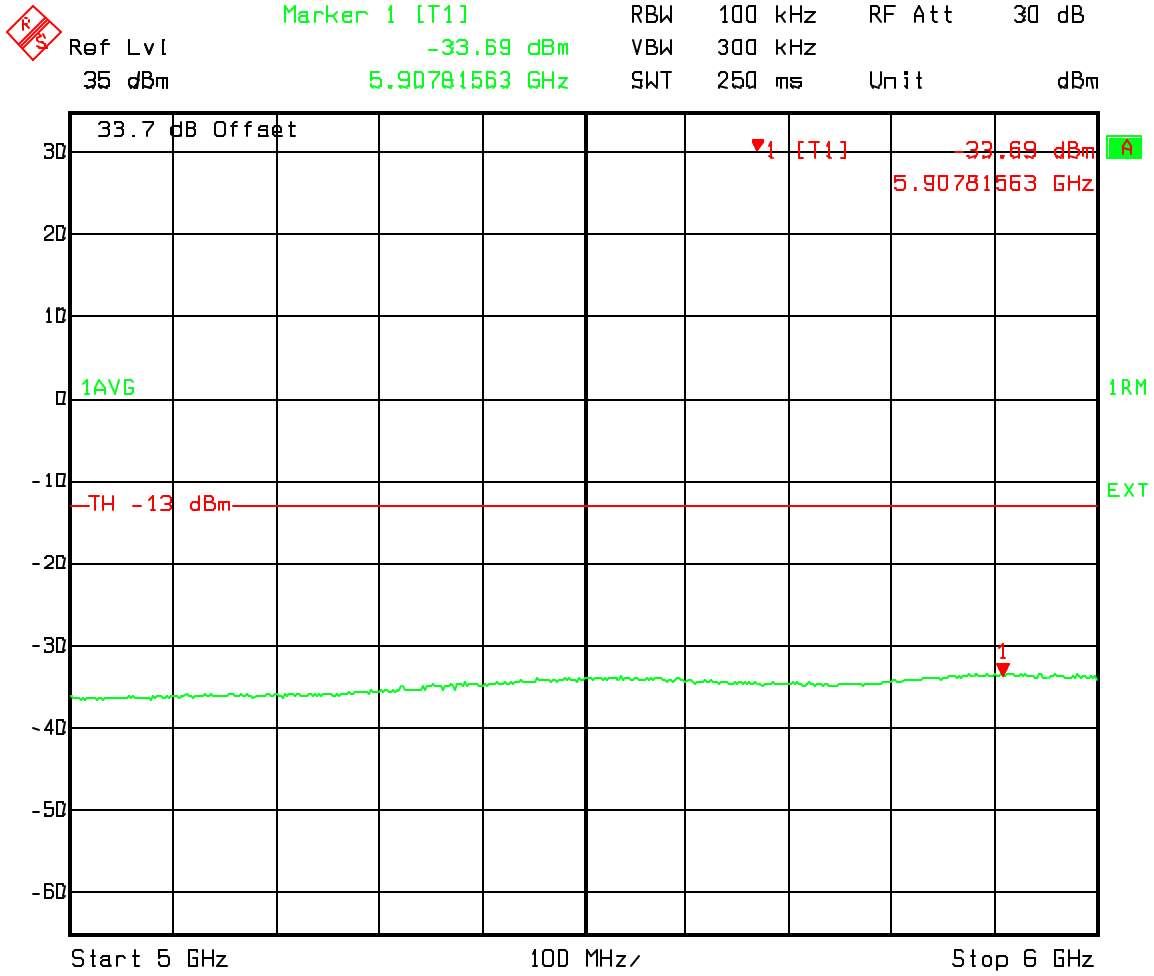

Date: 21.JAN.2004 2:25:19

**Single Chan 1015 and 308 Spurious Emissions at the 800 MHz MFRM2 Ant. Port
one Carrier band A and A'' IS 856**

A'' and A Band IS856 Spurious emissions 6000-7000 MHz

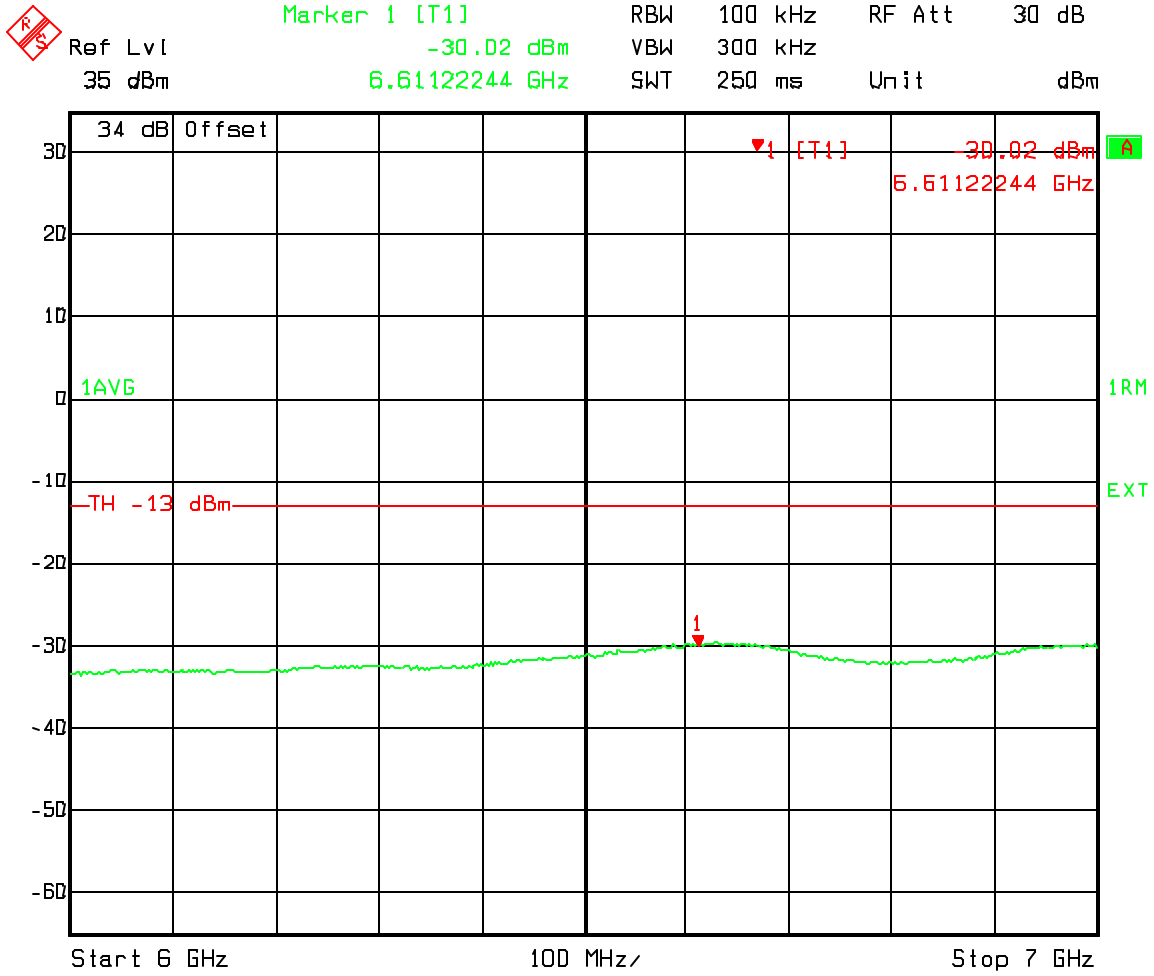

Date: 21.JAN.2004 2:26:11

**Single Chan 1015 and 308 Spurious Emissions at the 800 MHz MFRM2 Ant. Port
one Carrier band A and A'' IS 856**

A'' and A Band IS856 Spurious emissions 7000-8000 MHz

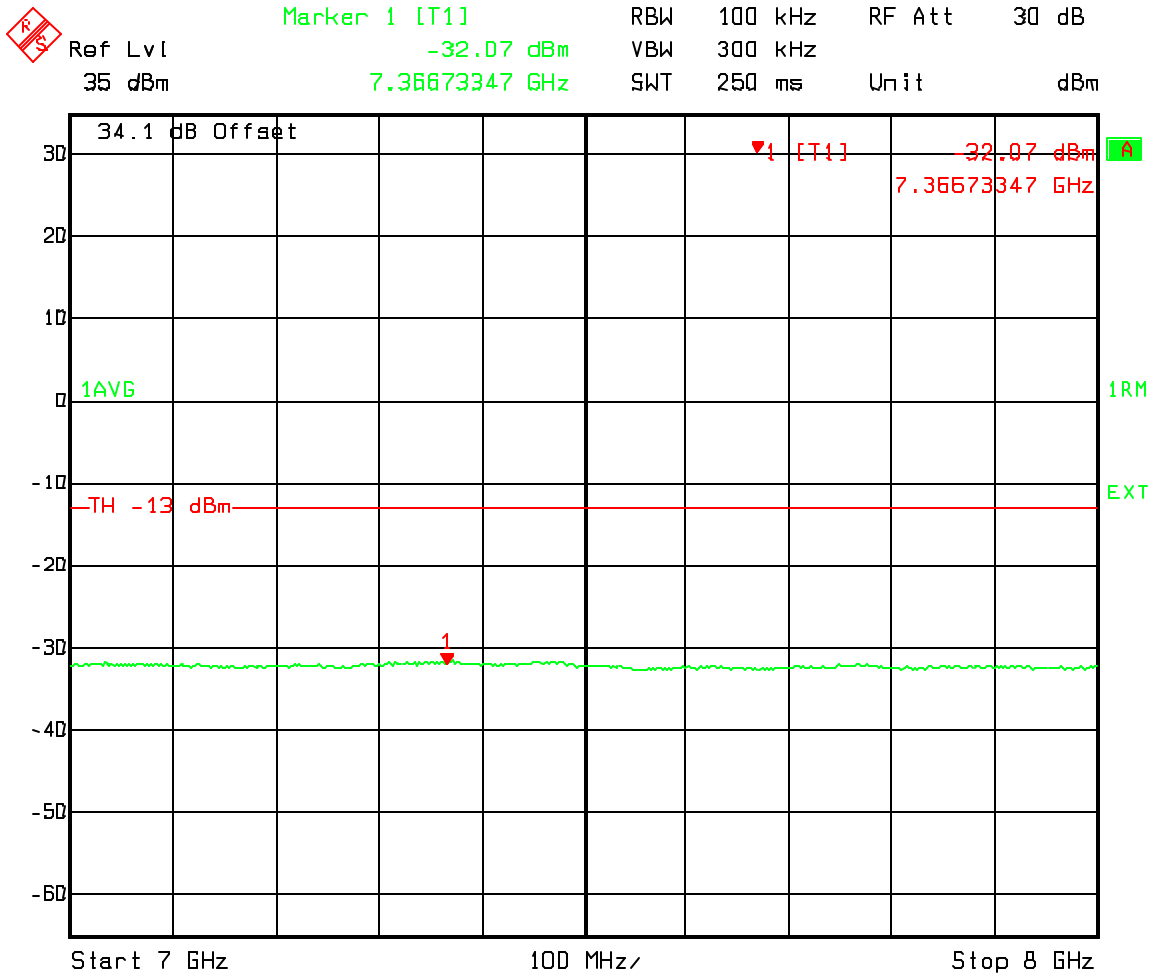

Date: 21.JAN.2004 2:27:07

Single Chan 1015 and 308 Spurious Emissions at the 800 MHz MFRM2 Ant. Port one Carrier band A and A'' IS 856

A'' and A Band IS856 Spurious emissions 8000-9000 MHz

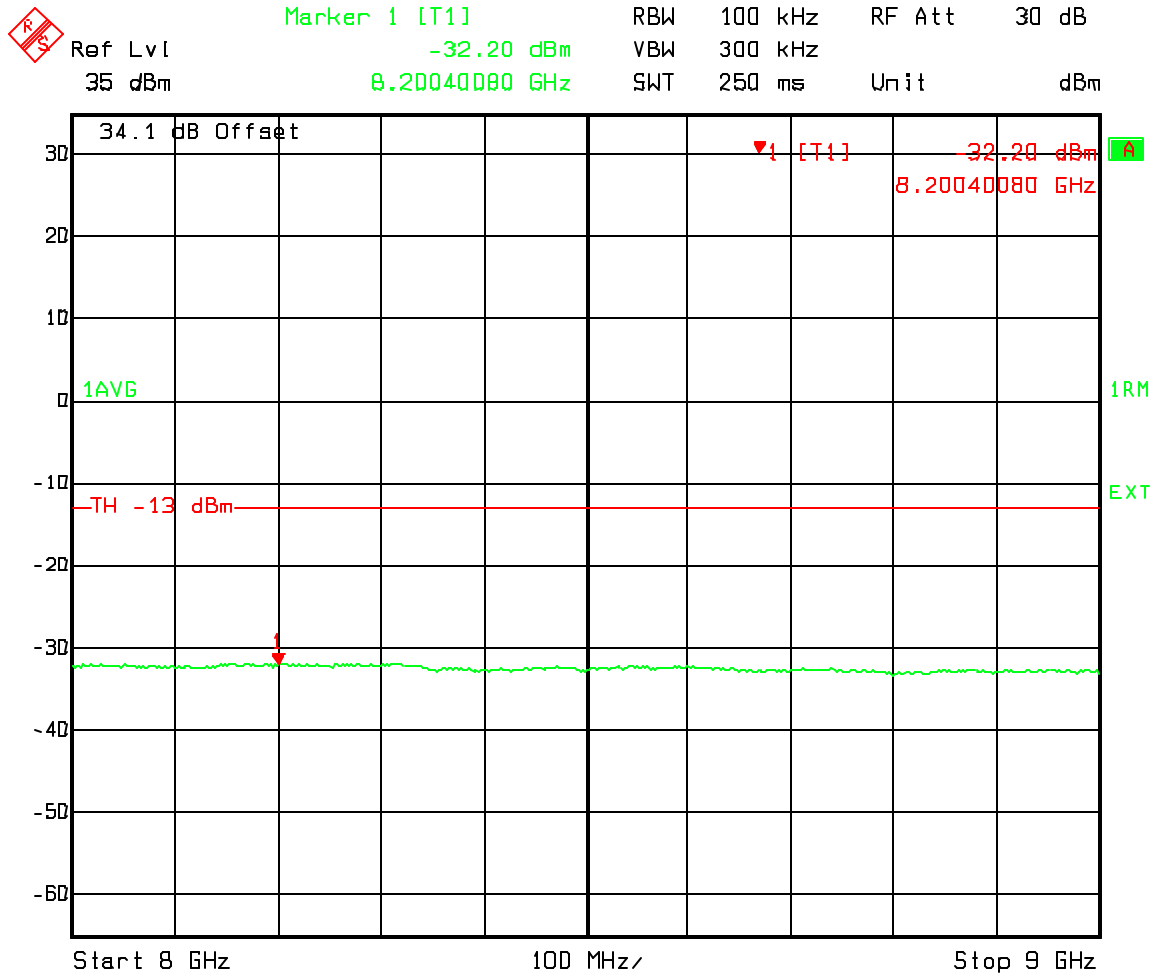

Date: 21.JAN.2004 2:28:00

**Single Chan 1015 and 308 Spurious Emissions at the 800 MHz MFRM2 Ant. Port
one Carrier band A and A'' IS 856**

A'' and A Band IS856 Spurious emissions 9000-10000 MHz

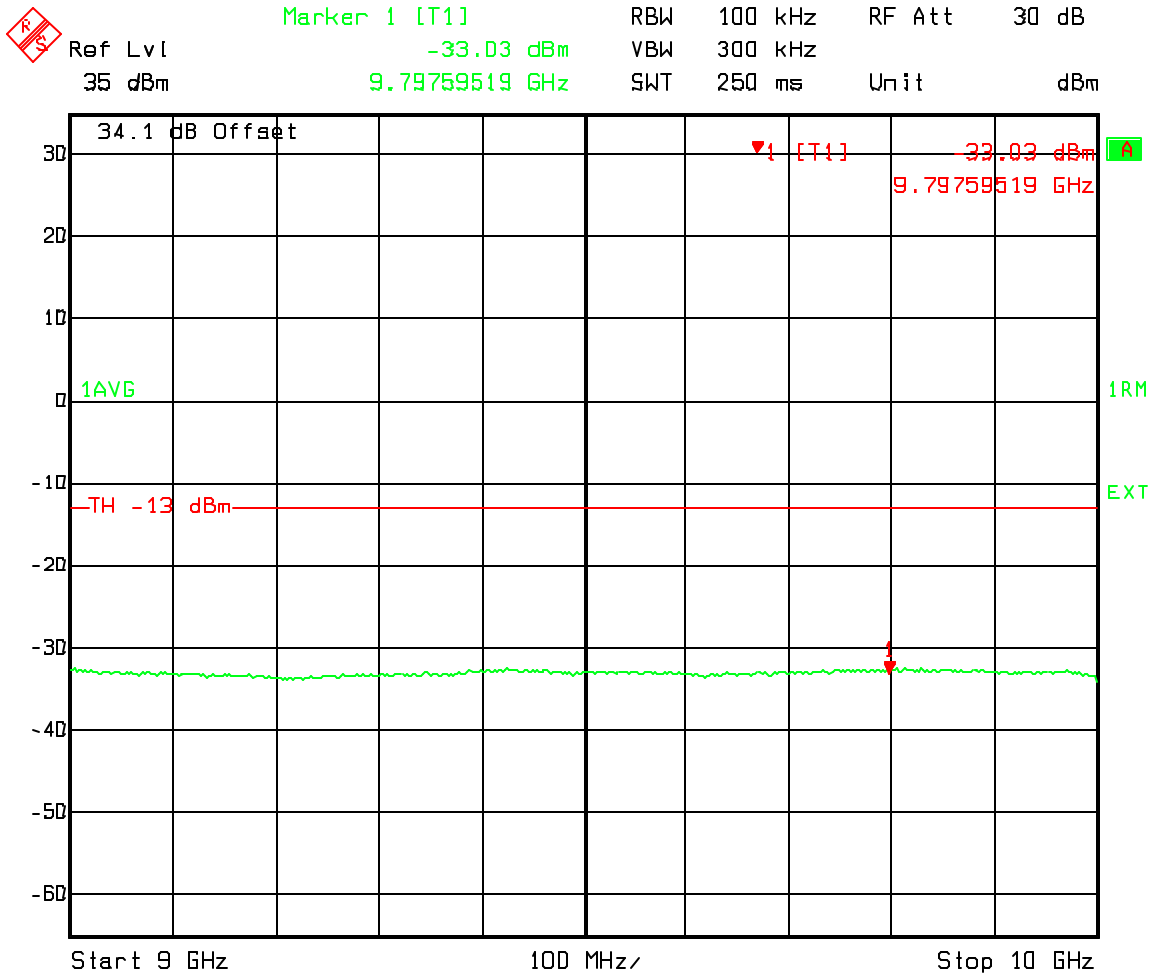

Date: 21.JAN.2004 2:28:56

Three Channel 1015, 33, 73 and 226, 267, 308 Spurious Emissions at the 800 MHz MFRM2 Ant. Port Three Carrier band A and A'' IS856

Occupied Bandwidth Ch 1015, 33, 74, 74A''

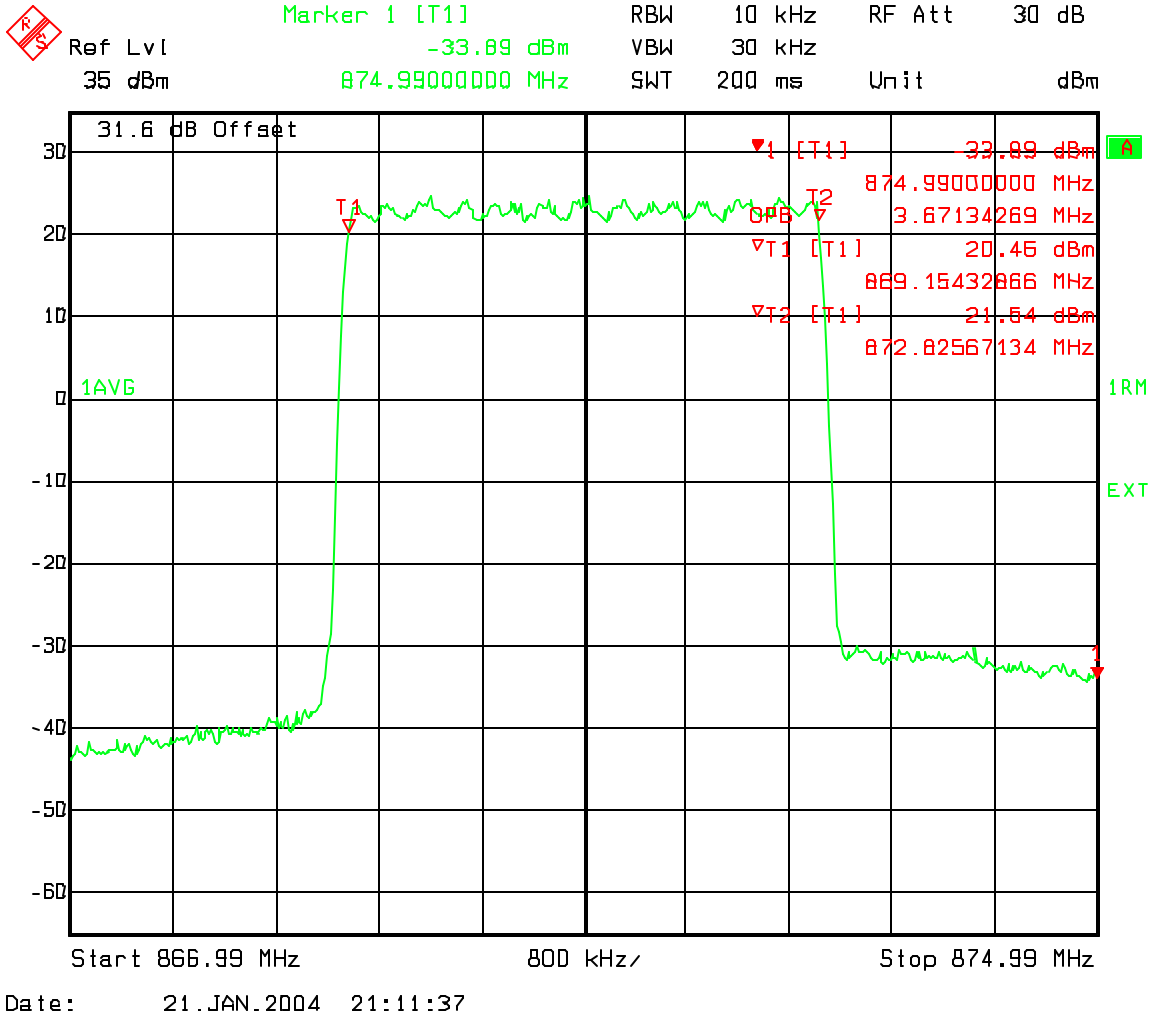

Three Channel 1015, 33, 73 and 226, 267, 308 Spurious Emissions at the 800 MHz MFRM2 Ant. Port Three Carrier band A and A'' IS856

A'' Band Ch 1015, 33, 74, 74 IS856 Adjacent 1Mhz Lower emissions 868-869MHz

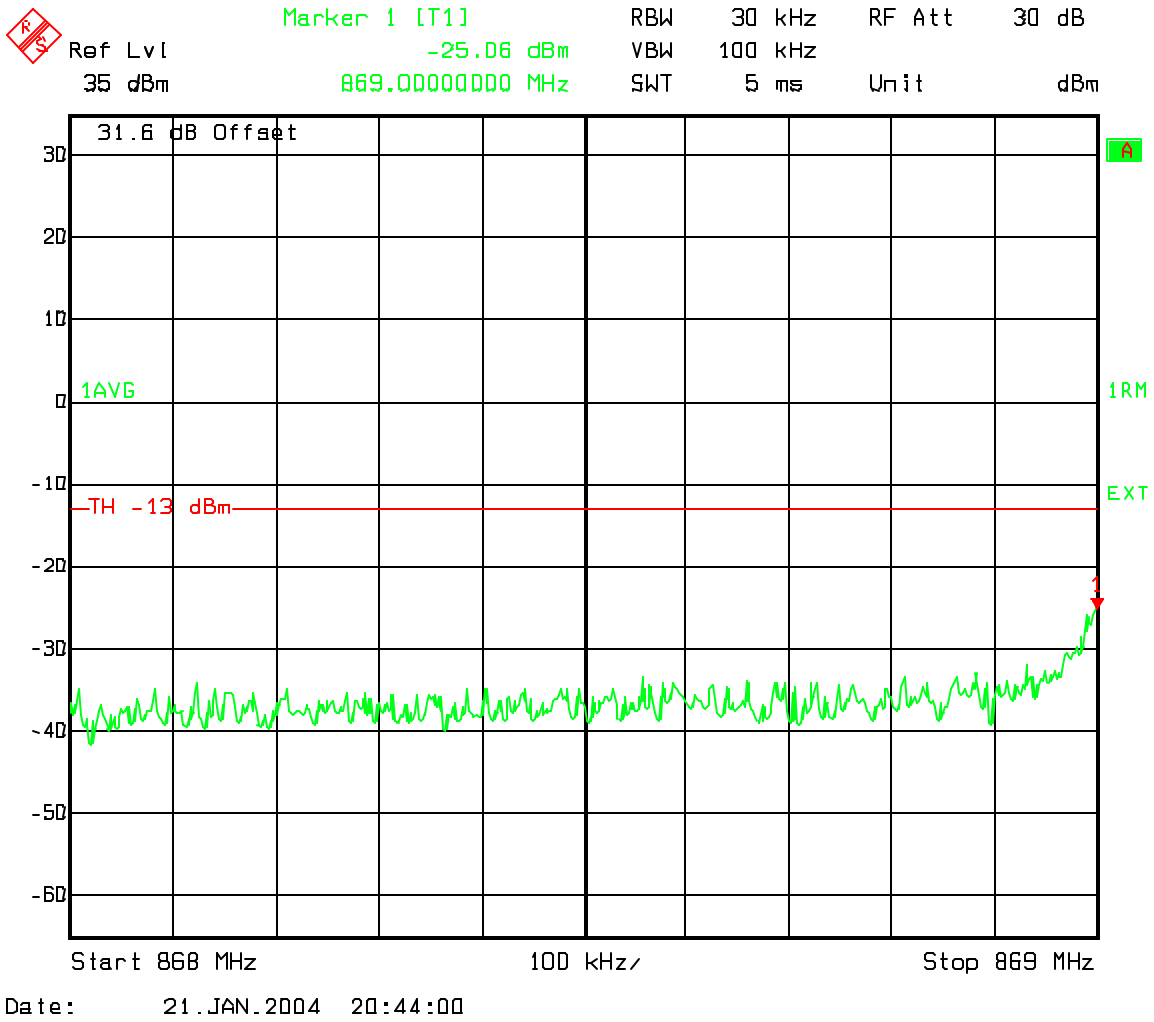

Three Channel 1015, 33, 73 and 226, 267, 308 Spurious Emissions at the 800 MHz MFRM2 Ant. Port Three Carrier band A and A'' IS856

A'' Band Ch1015, 33, 74, 74 IS856 Channel power Adjacent 37.5 kHz Lower emissions to 869 MHz

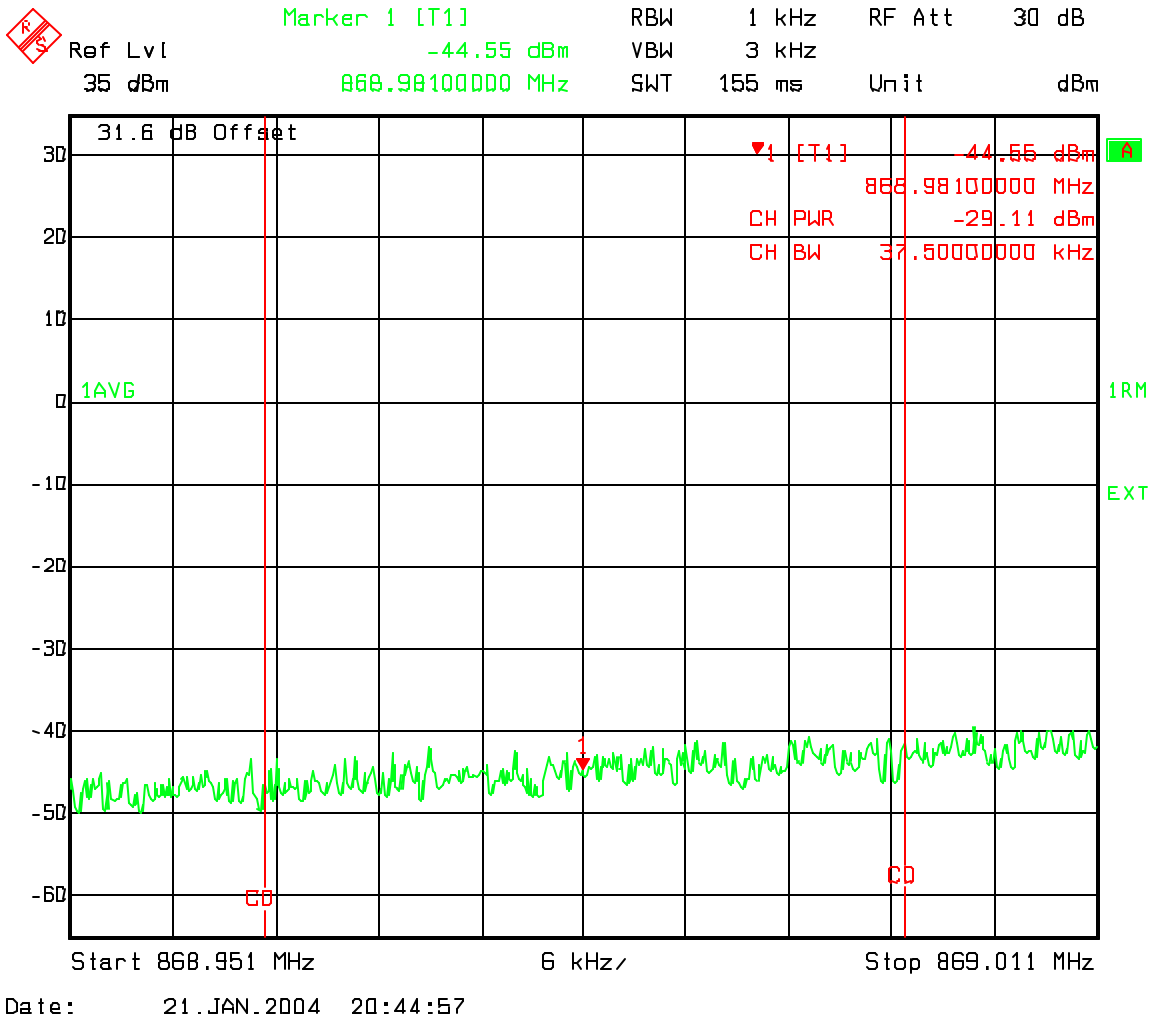

Three Channel 1015, 33, 73 and 226, 267, 308 Spurious Emissions at the 800 MHz MFRM2 Ant. Port Three Carrier band A and A'' IS856

Ch 226, 267, 308 Upper A Band adjacent 1MHz band emissions 880-881 MHz

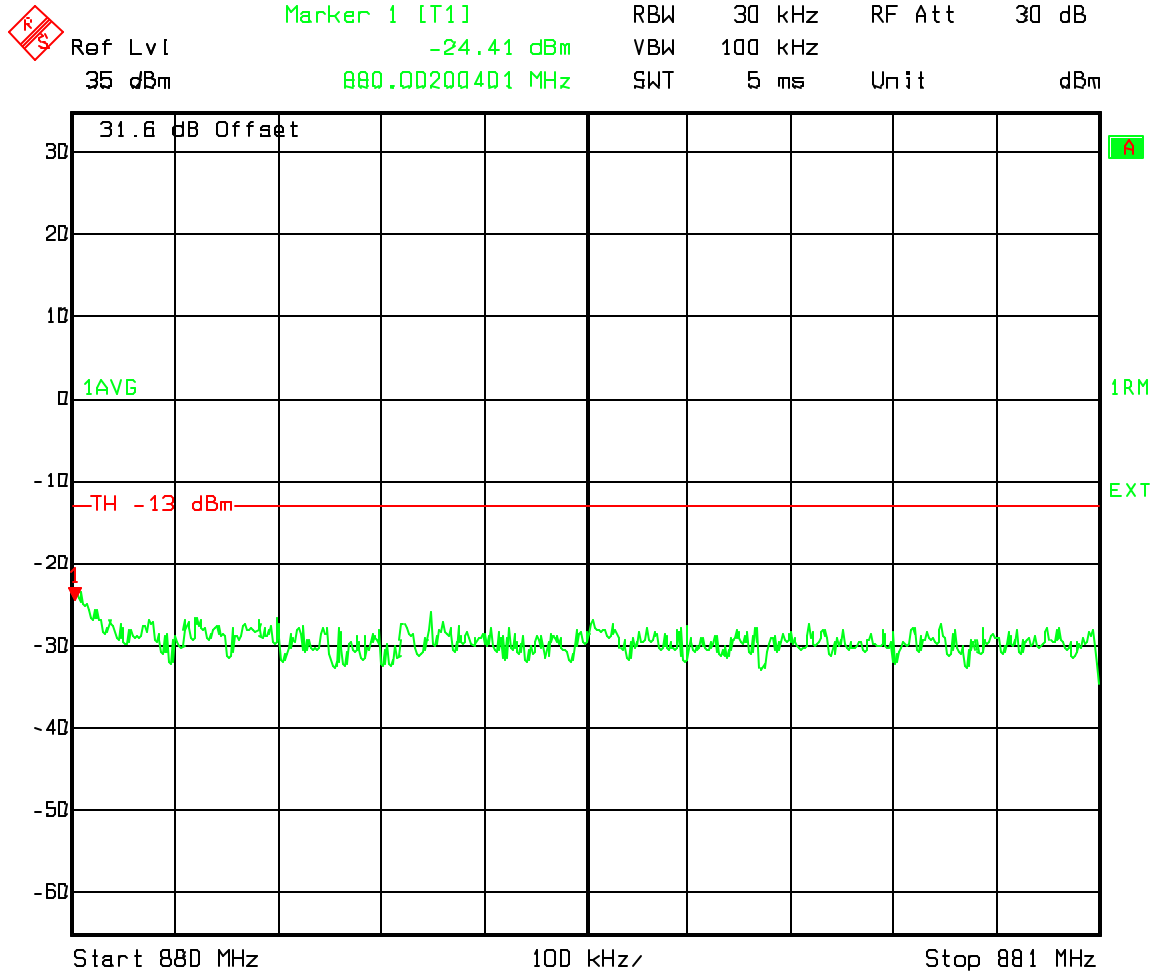

Date: 22.JAN.2004 18:07:18

Three Channel 1015, 33, 73 and 226, 267, 308 Spurious Emissions at the 800 MHz MFRM2 Ant. Port Three Carrier band A and A'' IS856

Ch 226, 267, 308 Upper A Band adjacent to outside edge 37.5 kHz band Channel power

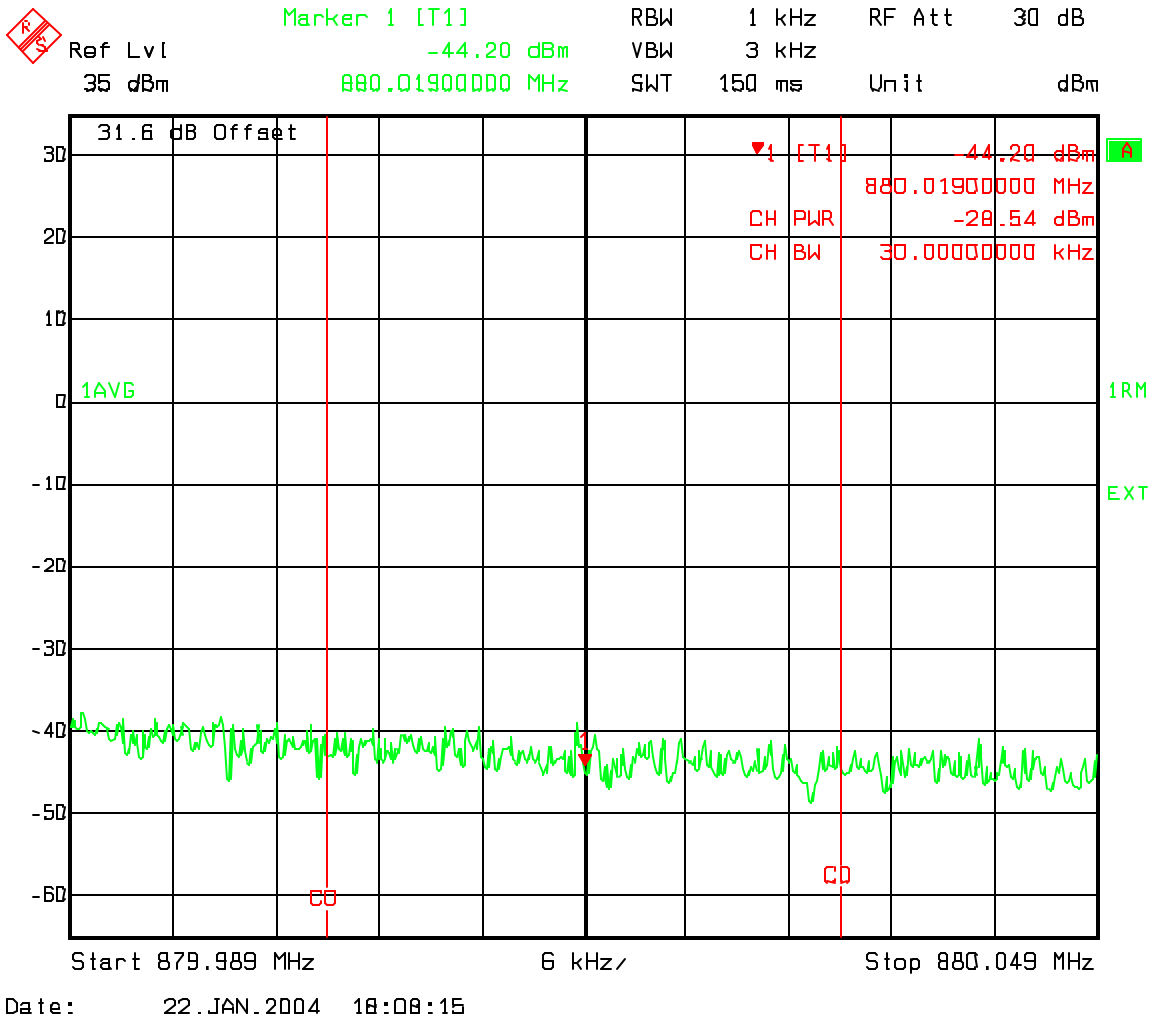

Three Channel 1015, 33, 73 and 226, 267, 308 Spurious Emissions at the 800 MHz MFRM2 Ant. Port Three Carrier band A and A'' IS856

Industry Canada Lower 750 kHz offset 30kHz Chan Power Ch 1015, 33, 74

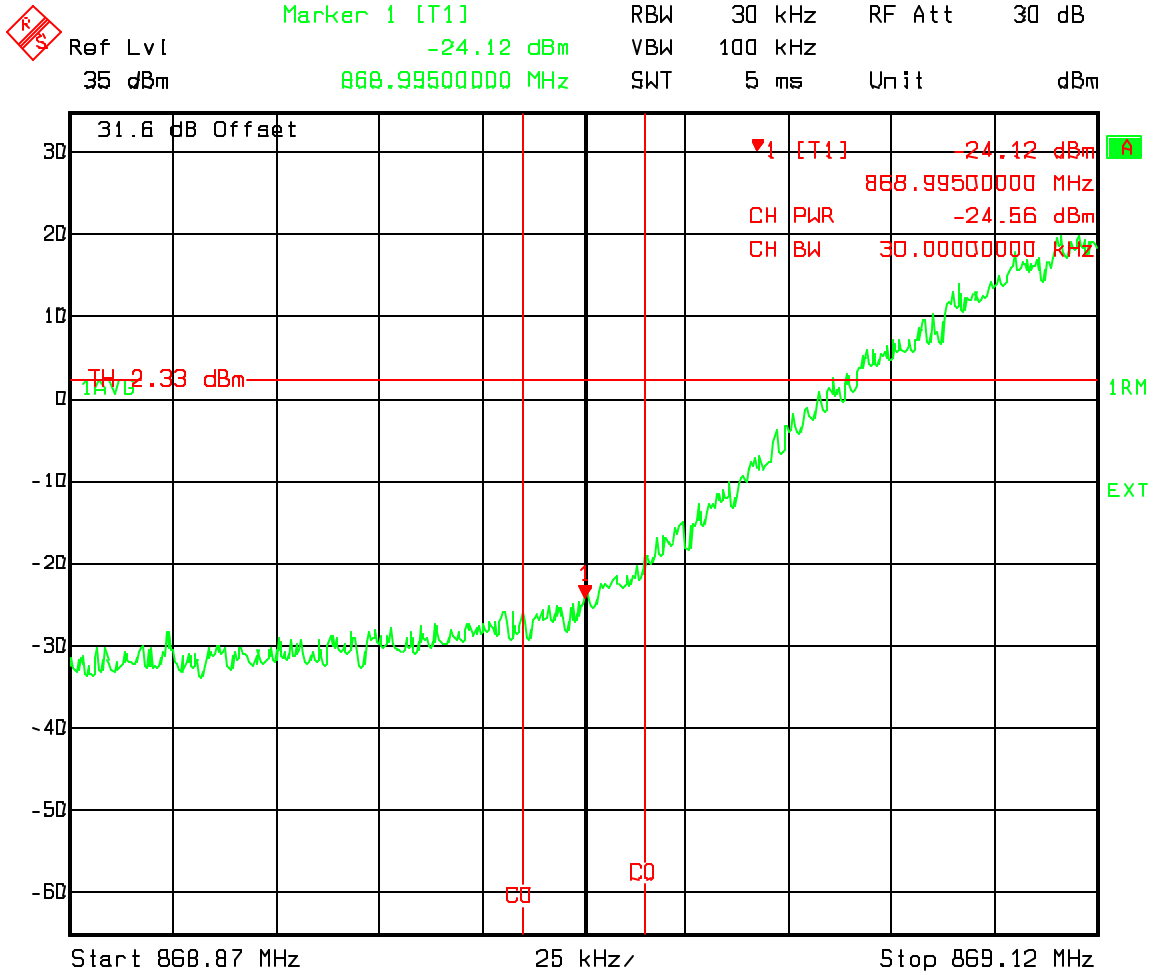

Date: 21.JAN.2004 21:13:21

Three Channel 1015, 33, 73 and 226, 267, 308 Spurious Emissions at the 800 MHz MFRM2 Ant. Port Three Carrier band A and A'' IS856

Industry Canada Upper 750 kHz offset 30kHz Chan Power Ch 1015, 33, 74,74

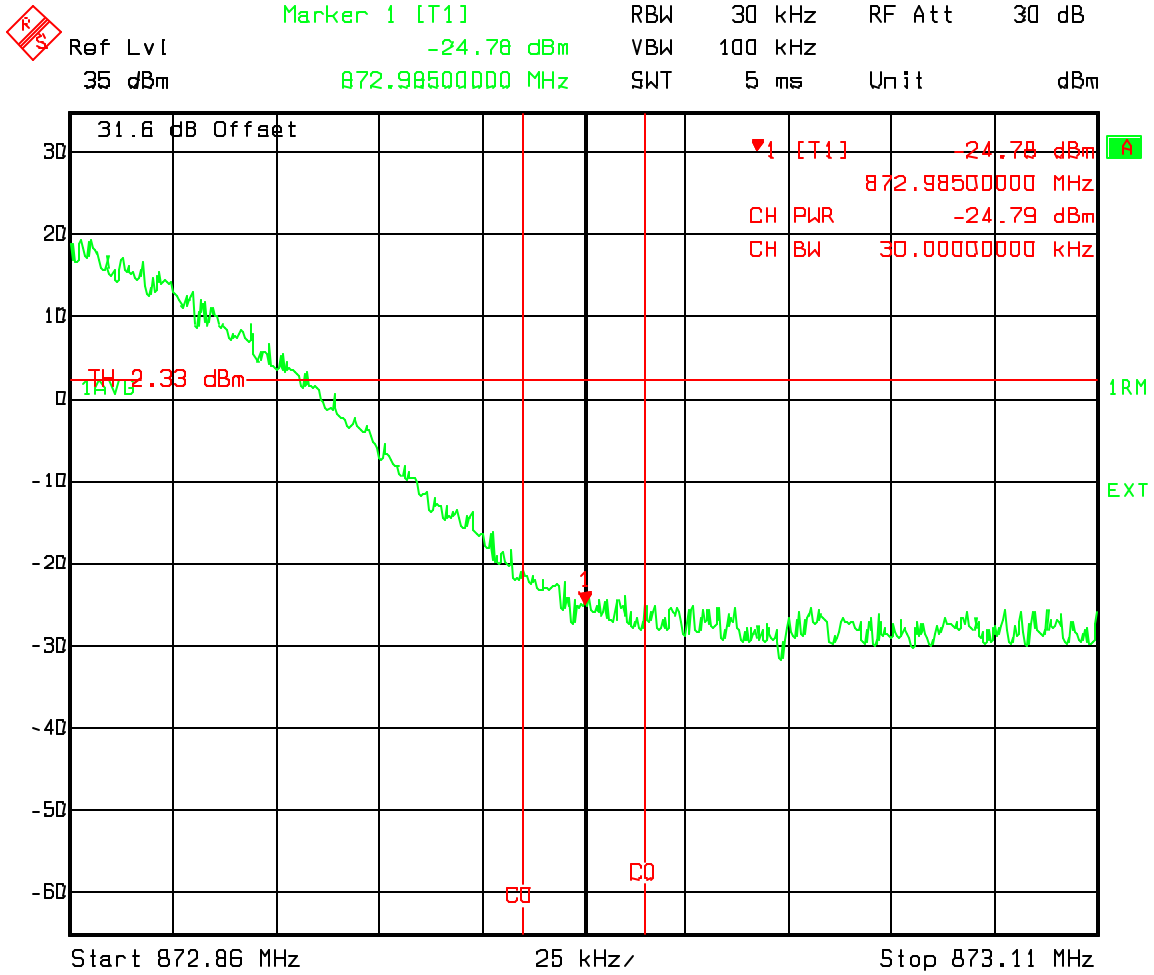

Date: 21.JAN.2004 21:14:15

Three Channel 1015, 33, 73 and 226, 267, 308 Spurious Emissions at the 800 MHz MFRM2 Ant. Port Three Carrier band A and A'' IS856

Industry Canada 1.98 MHz offset Lower 30kHz Chan Power Ch 1015, 33, 74

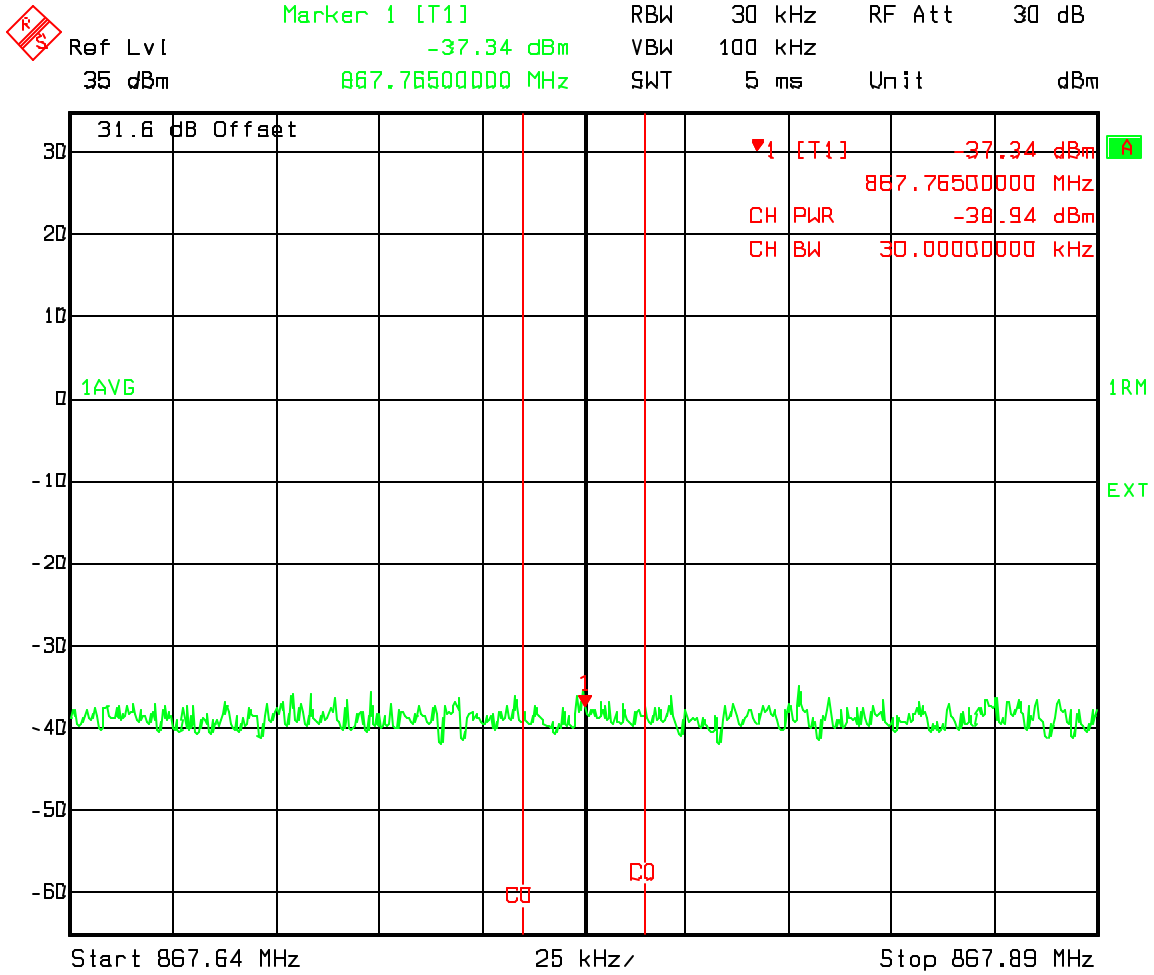

Date: 21.JAN.2004 21:15:10

Three Channel 1015, 33, 73 and 226, 267, 308 Spurious Emissions at the 800 MHz MFRM2 Ant. Port Three Carrier band A and A'' IS856

Industry Canada 1.98 MHz offset Upper 30kHz Chan Power Ch 1015, 33, 74

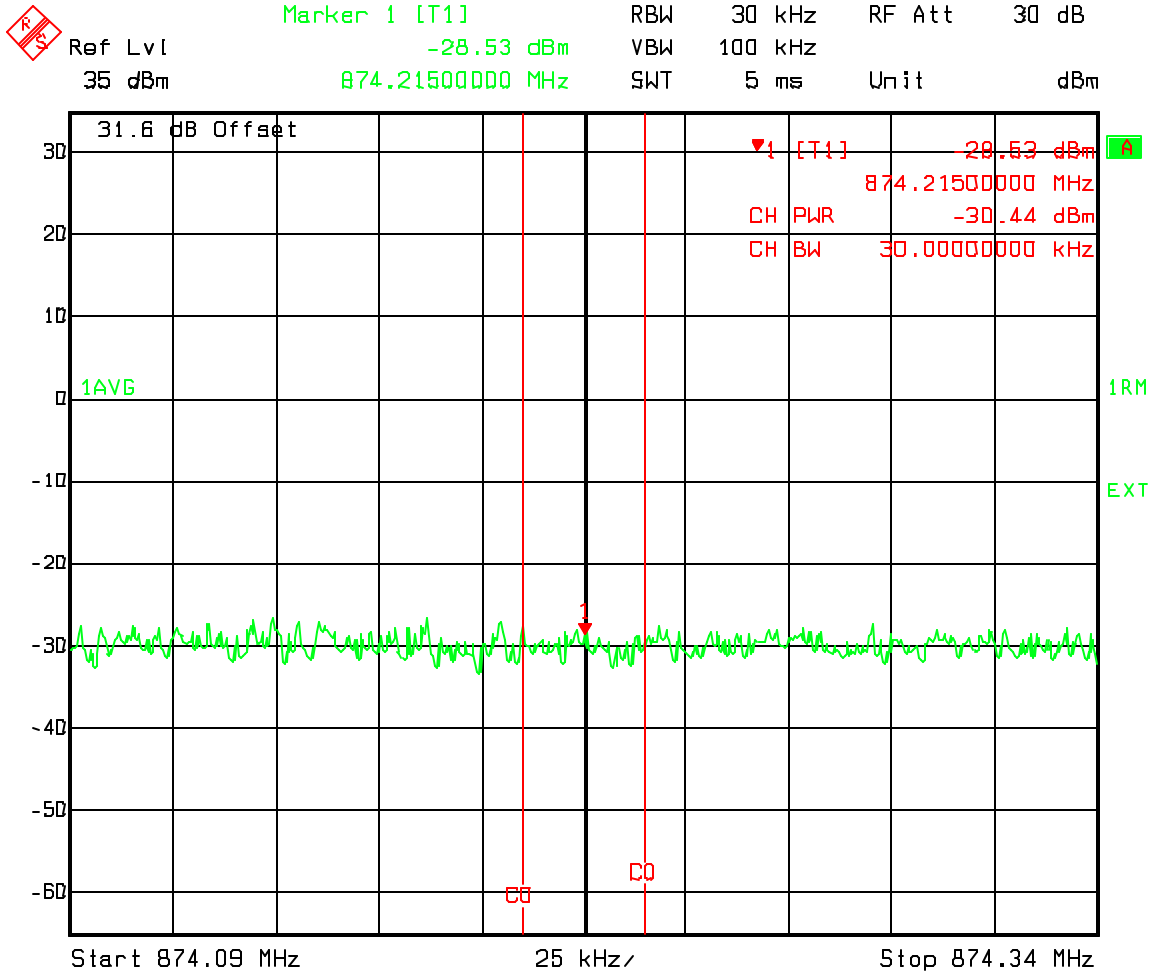

Date: 21.JAN.2004 21:16:04

Three Channel 1015, 33, 73 and 226, 267, 308 Spurious Emissions at the 800 MHz MFRM2 Ant. Port Three Carrier band A and A'' IS856

A'' and A Band IS856 Spurious emissions 10kHz-400 MHz

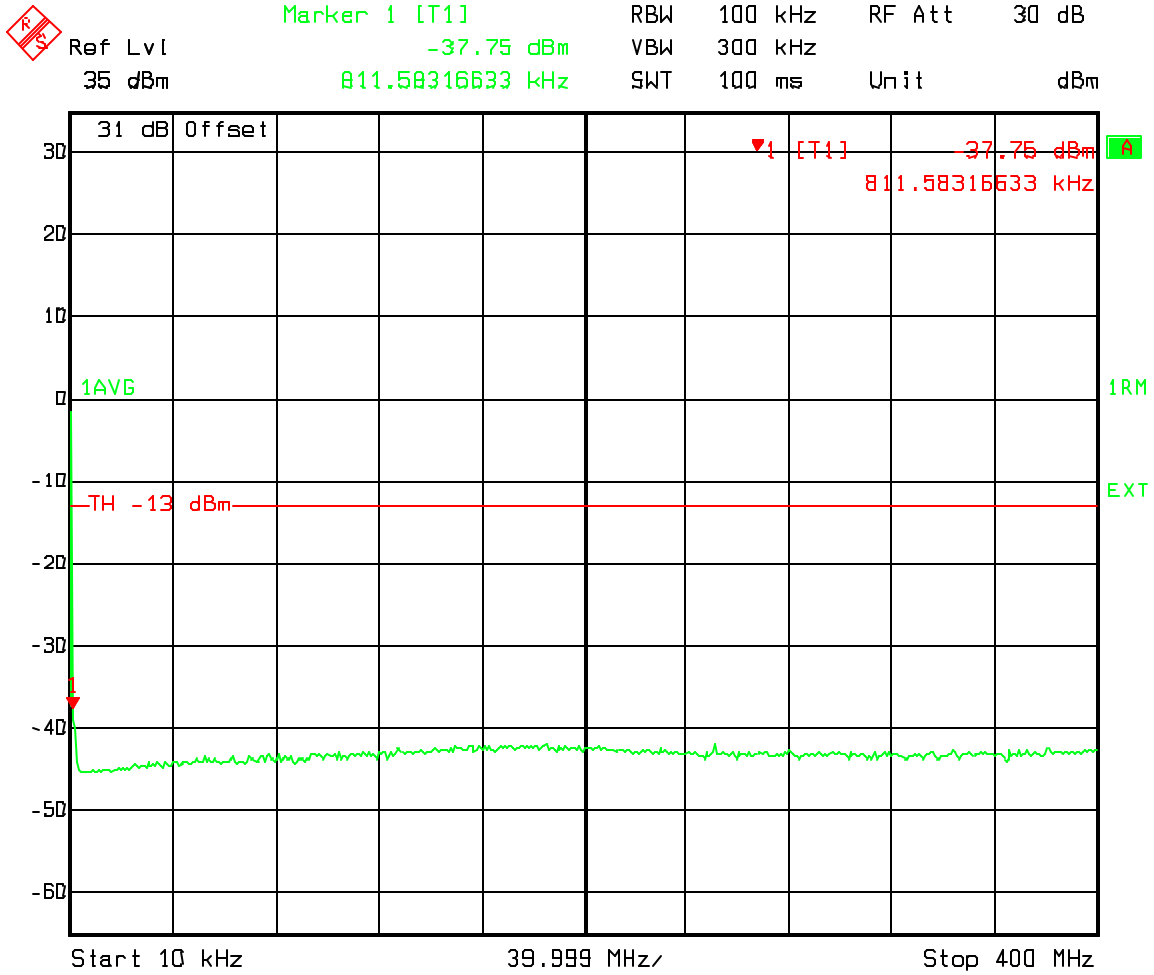

Date: 21.JAN.2004 20:47:57

Three Channel 1015, 33, 73 and 226, 267, 308 Spurious Emissions at the 800 MHz MFRM2 Ant. Port Three Carrier band A and A'' IS856

A'' and A Band IS856 Spurious emissions 400MHz to Lower 1MHz Band Edge

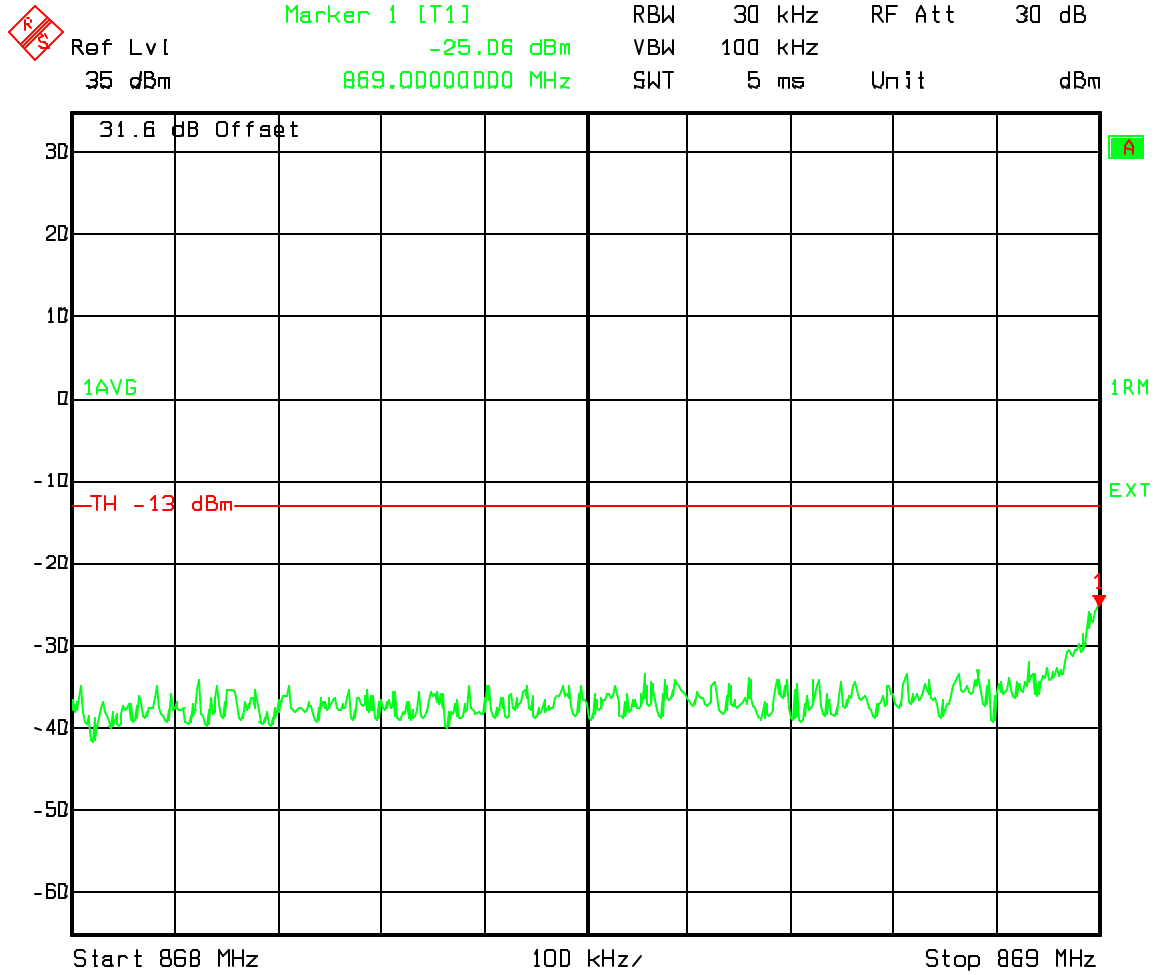

Date: 21.JAN.2004 20:44:00

Three Channel 1015, 33, 73 and 226, 267, 308 Spurious Emissions at the 800 MHz MFRM2 Ant. Port Three Carrier band A and A'' IS856

A'' and A Band IS856 Spurious emissions Upper 1MHz Band Edge to 1GHz

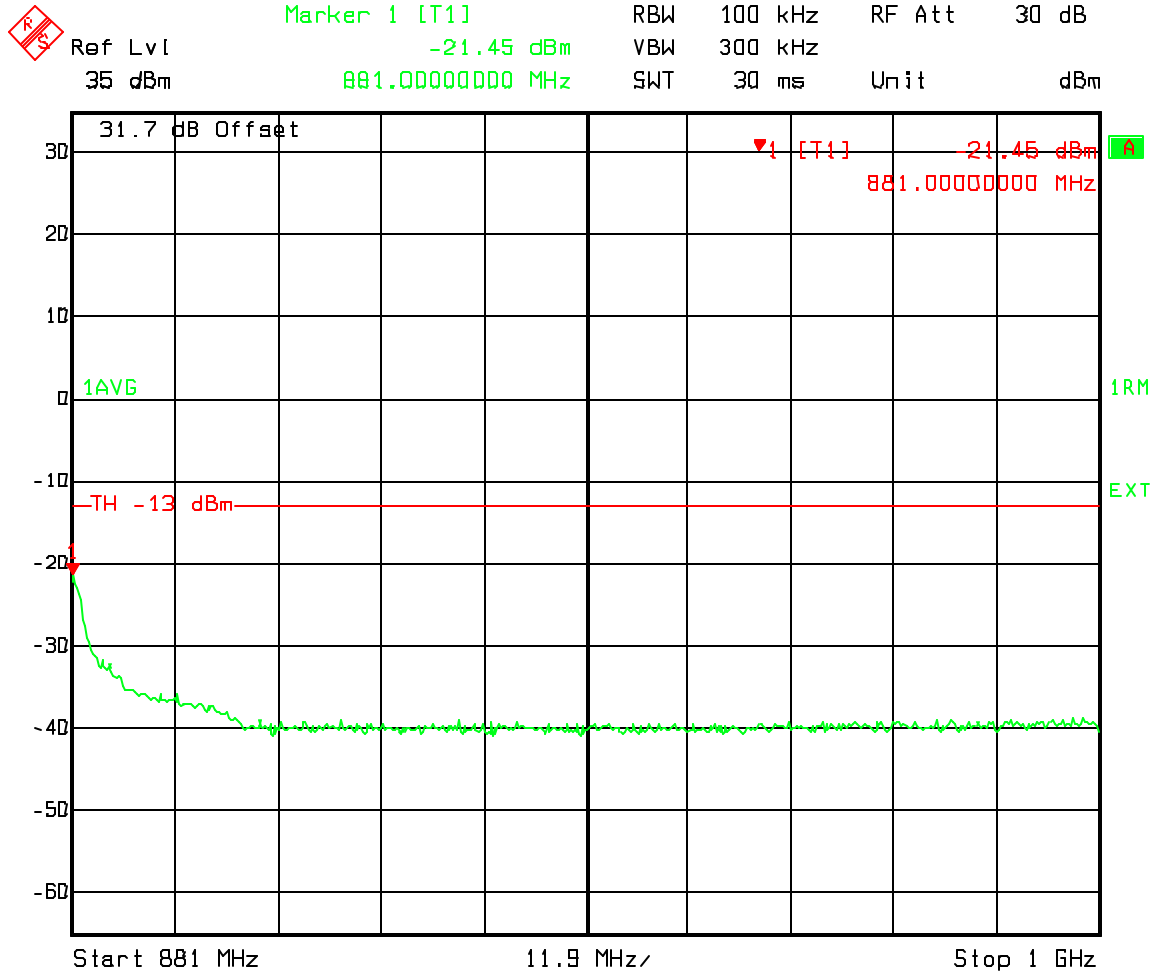

Date: 6.FEB.2004 7:52:16

Three Channel 1015, 33, 73 and 226, 267, 308 Spurious Emissions at the 800 MHz MFRM2 Ant. Port Three Carrier band A and A'' IS856

A'' and A Band IS856 Spurious emissions 400-1000 MHz

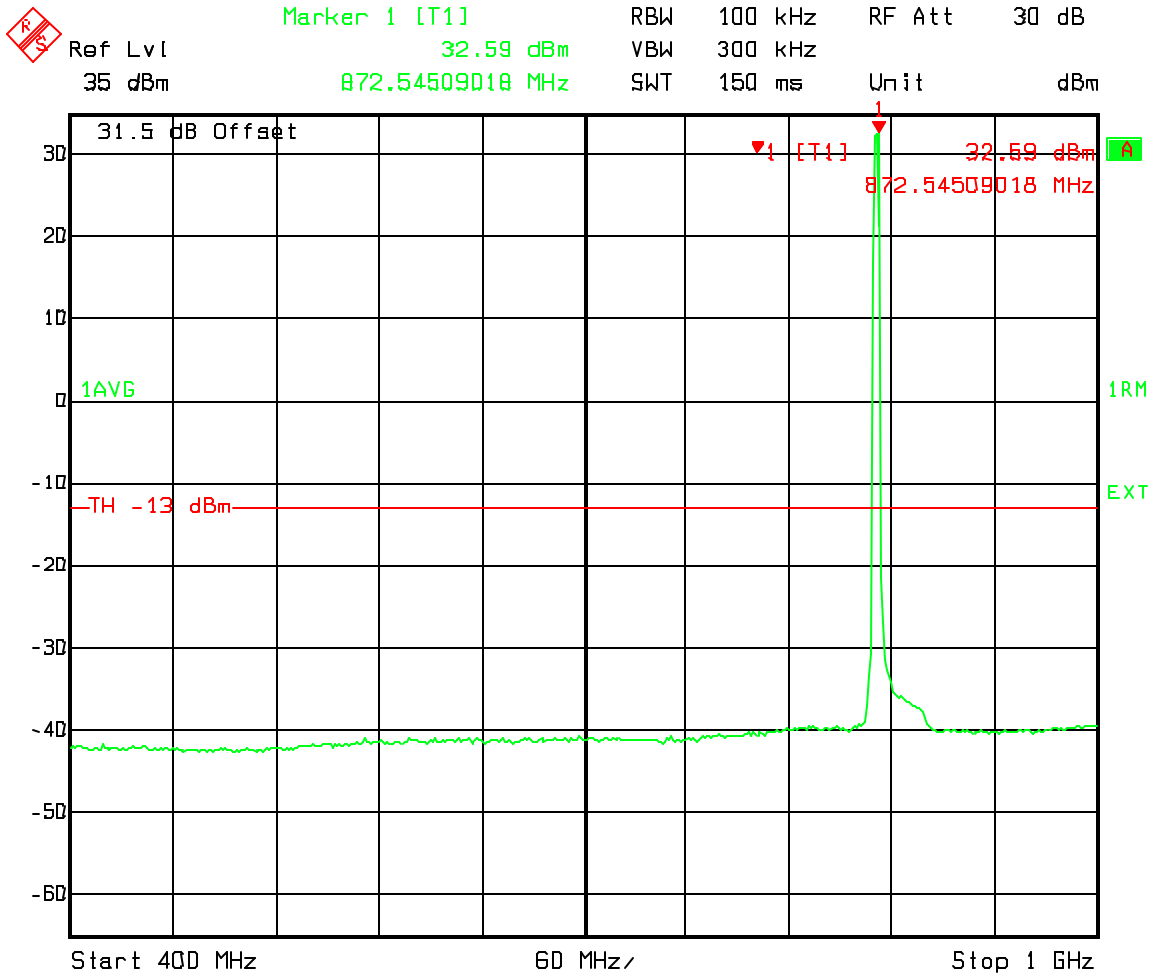

Date: 21.JAN.2004 20:48:56

Three Channel 1015, 33, 73 and 226, 267, 308 Spurious Emissions at the 800 MHz MFRM2 Ant. Port Three Carrier band A and A'' IS856

A'' and A Band IS856 Spurious emissions 1000-2000 MHz

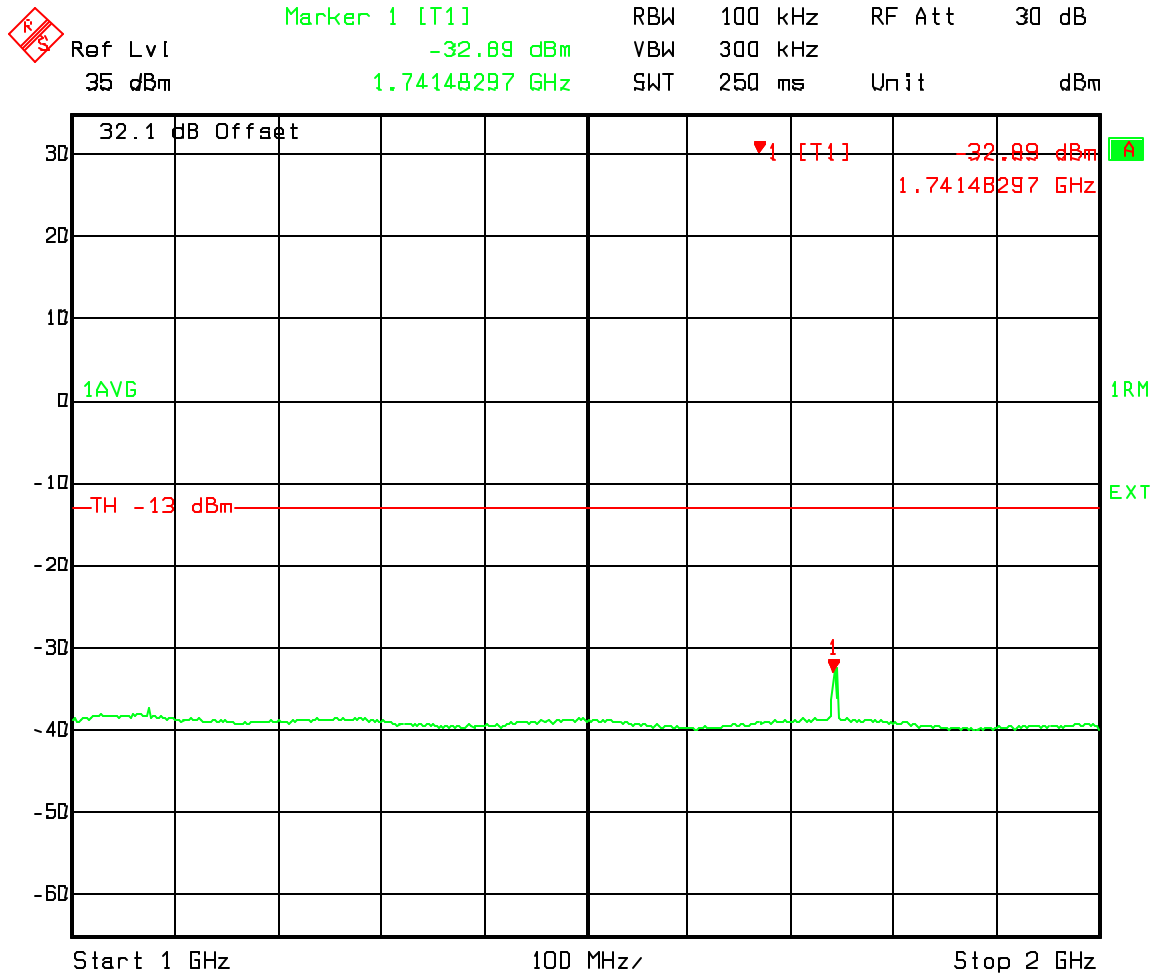

Date: 21.JAN.2004 20:49:53

Three Channel 1015, 33, 73 and 226, 267, 308 Spurious Emissions at the 800 MHz MFRM2 Ant. Port Three Carrier band A and A'' IS856

A'' and A Band IS856 Spurious emissions 2000-3000 MHz

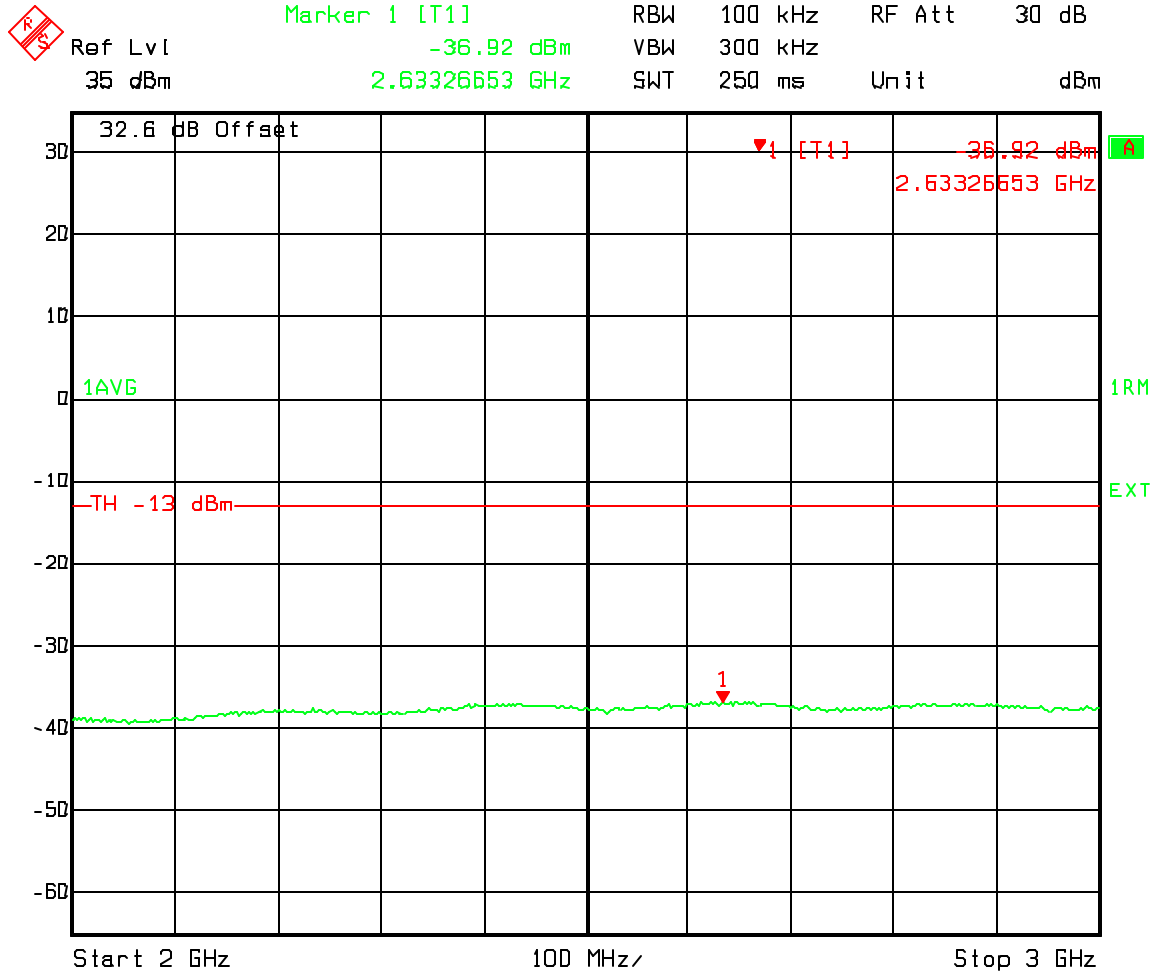

Date: 21.JAN.2004 20:50:53

Three Channel 1015, 33, 73 and 226, 267, 308 Spurious Emissions at the 800 MHz MFRM2 Ant. Port Three Carrier band A and A'' IS856

A'' and A Band IS856 Spurious emissions 3000-4000 MHz

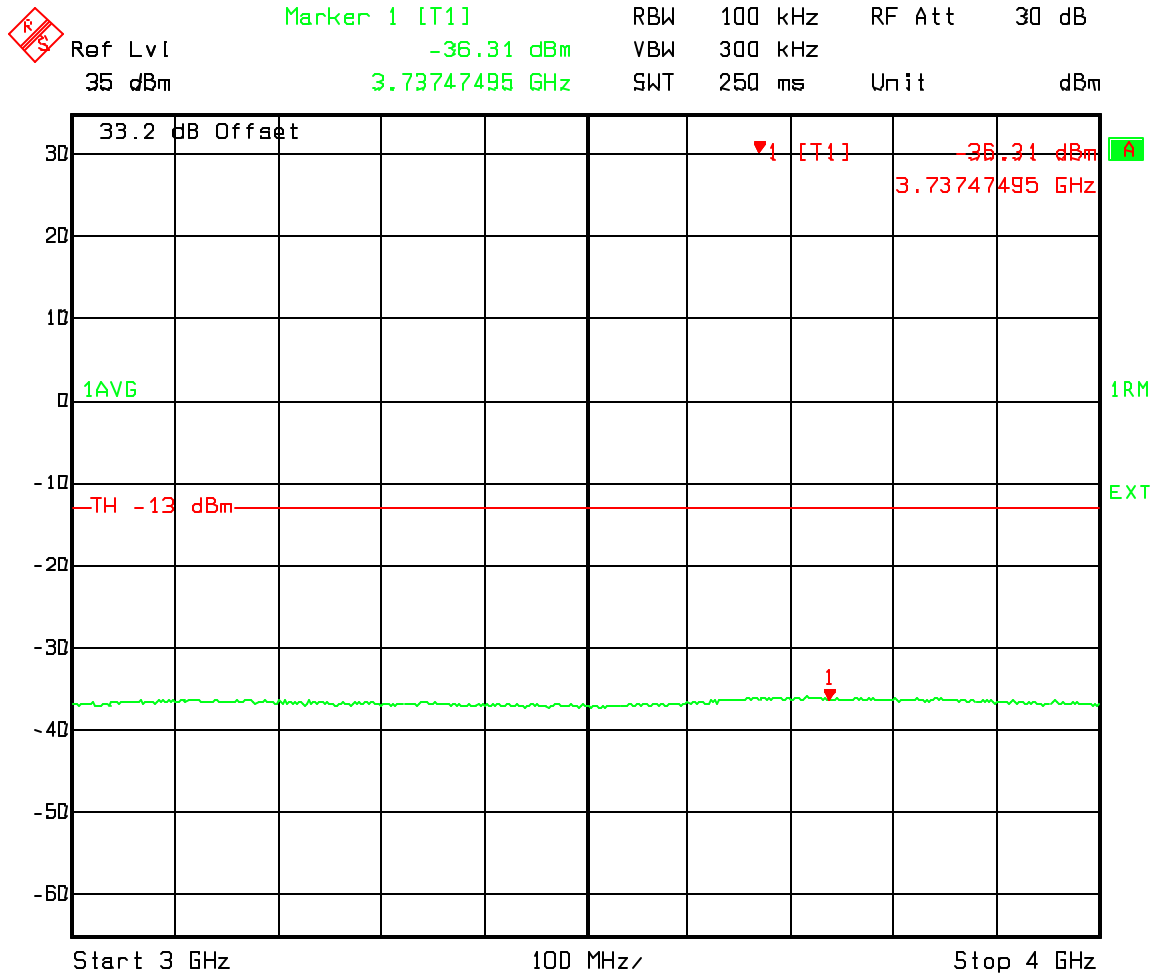

Date: 21.JAN.2004 20:51:50

Three Channel 1015, 33, 73 and 226, 267, 308 Spurious Emissions at the 800 MHz MFRM2 Ant. Port Three Carrier band A and A'' IS856

A'' and A Band IS856 Spurious emissions 4000-5000 MHz

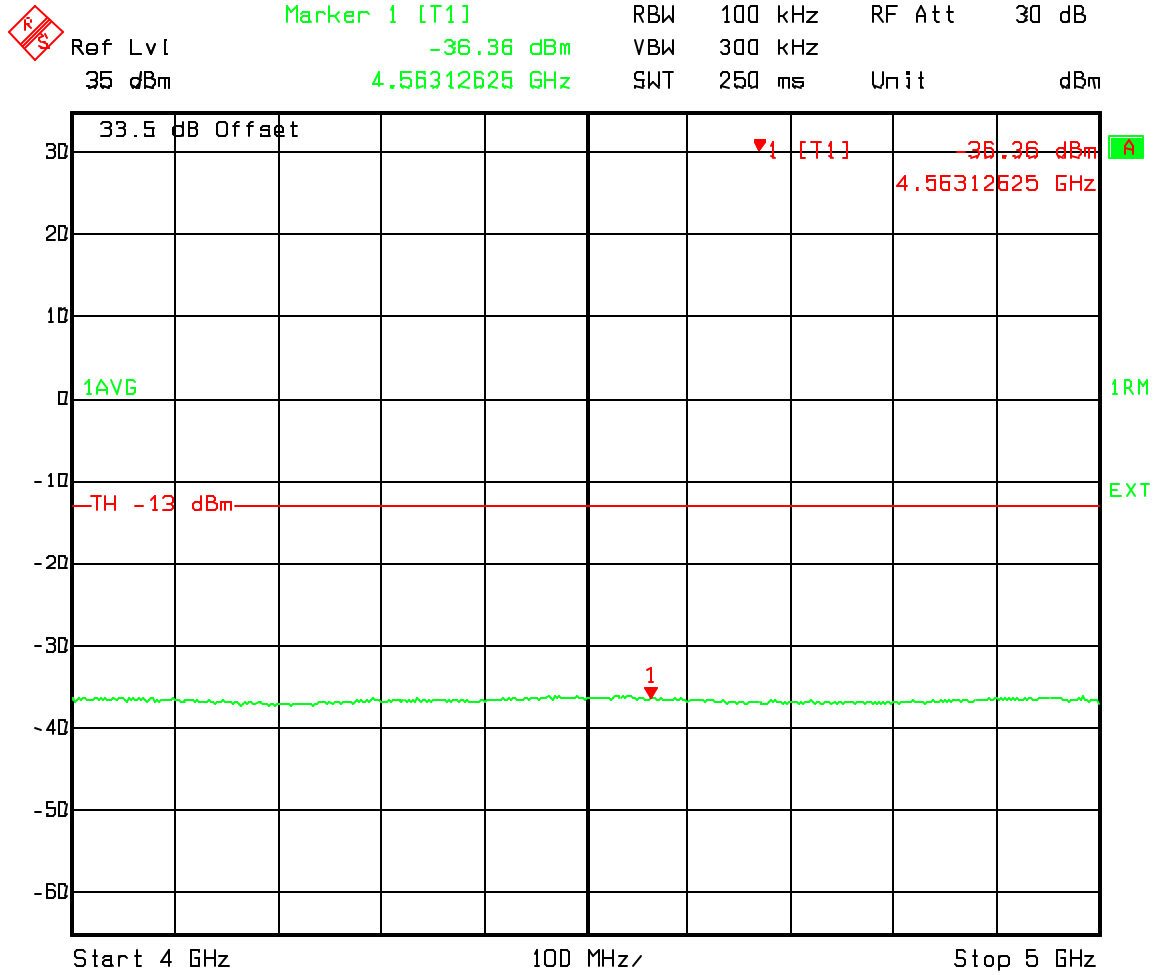

Date: 21.JAN.2004 20:52:48

Three Channel 1015, 33, 73 and 226, 267, 308 Spurious Emissions at the 800 MHz MFRM2 Ant. Port Three Carrier band A and A'' IS856

A'' and A Band IS856 Spurious emissions 5000-6000 MHz

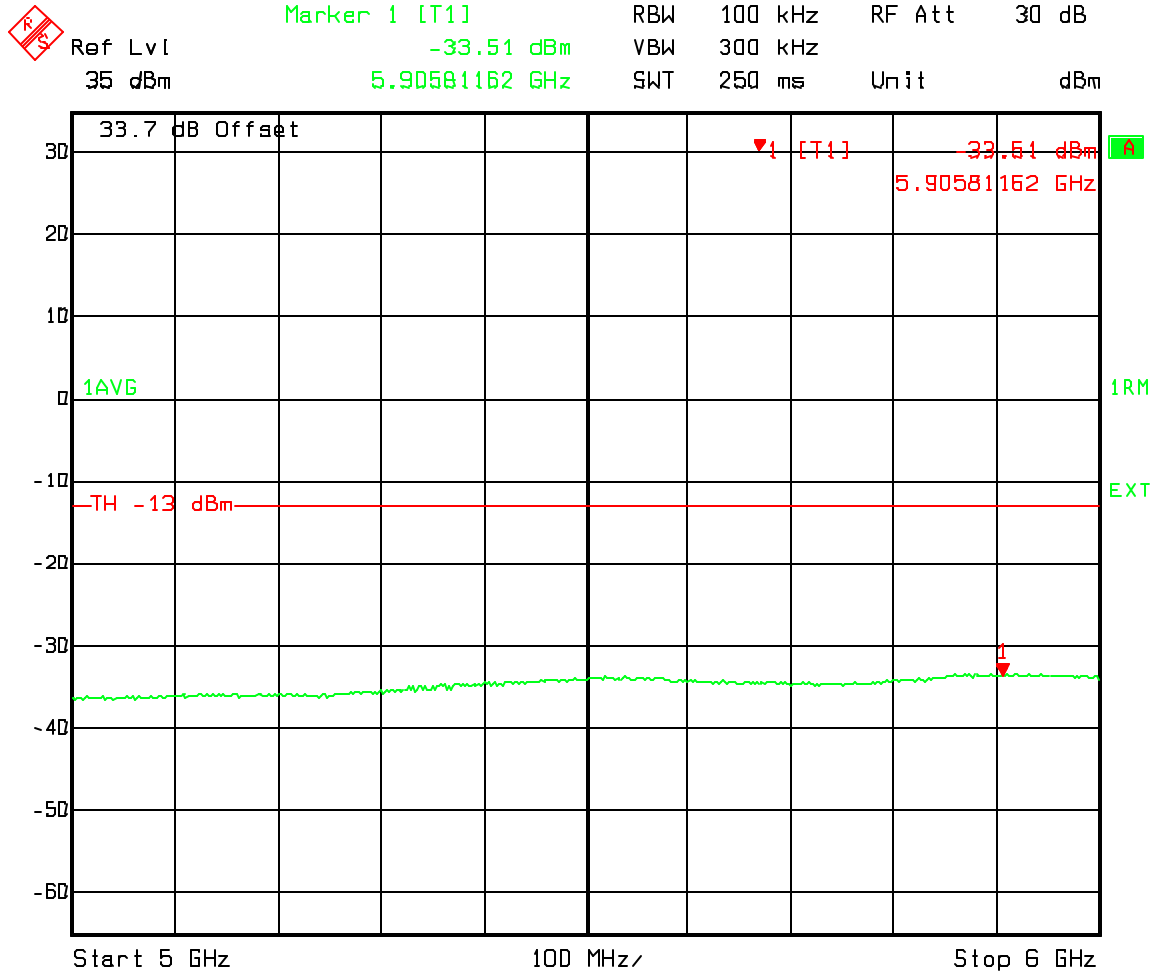

Date: 21.JAN.2004 20:53:49

Three Channel 1015, 33, 73 and 226, 267, 308 Spurious Emissions at the 800 MHz MFRM2 Ant. Port Three Carrier band A and A'' IS856

A'' and A Band IS856 Spurious emissions 6000-7000 MHz

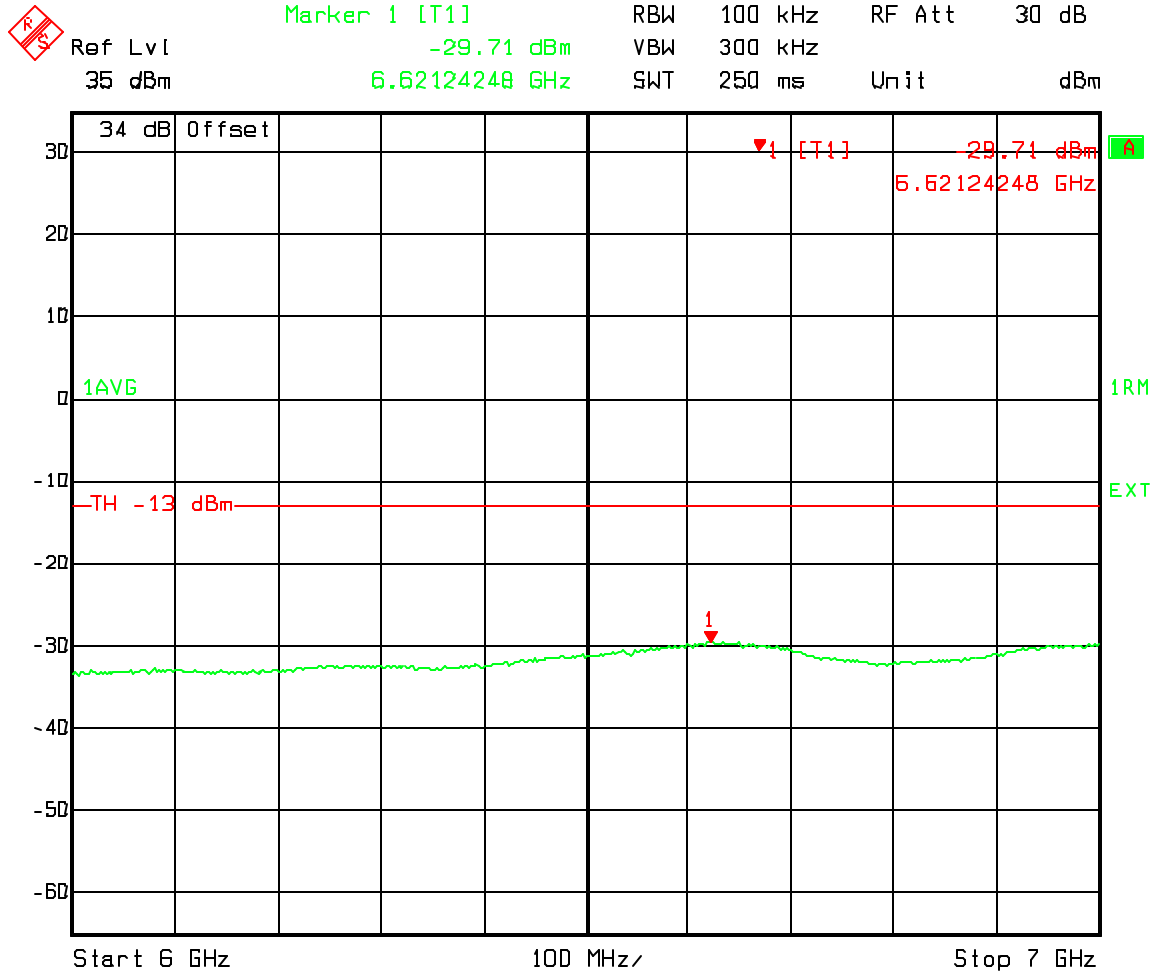

Date: 21.JAN.2004 20:54:48

Three Channel 1015, 33, 73 and 226, 267, 308 Spurious Emissions at the 800 MHz MFRM2 Ant. Port Three Carrier band A and A'' IS856

A'' and A Band IS856 Spurious emissions 7000-8000 MHz

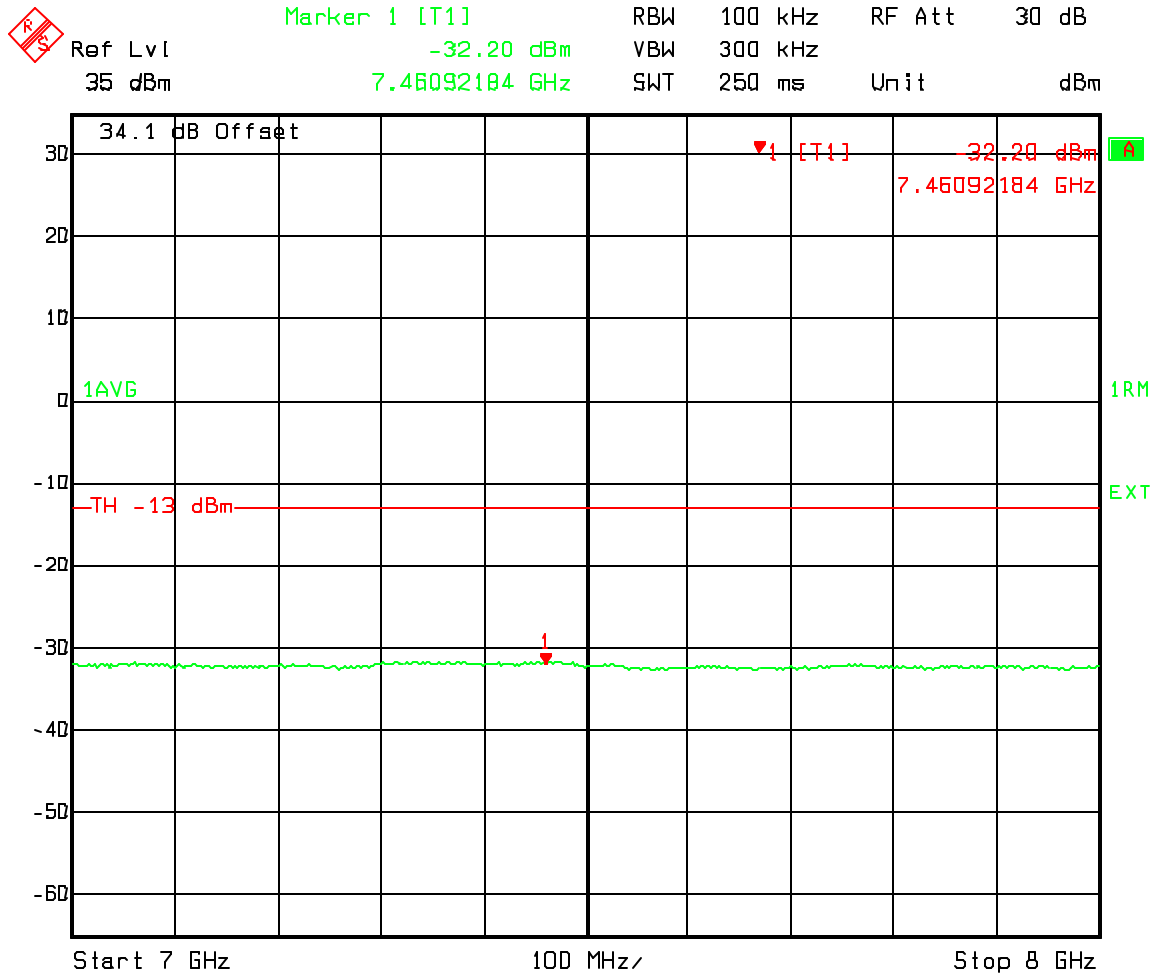

Date: 21.JAN.2004 20:55:49

Three Channel 1015, 33, 73 and 226, 267, 308 Spurious Emissions at the 800 MHz MFRM2 Ant. Port Three Carrier band A and A'' IS856

A'' and A Band IS856 Spurious emissions 8000-9000 MHz

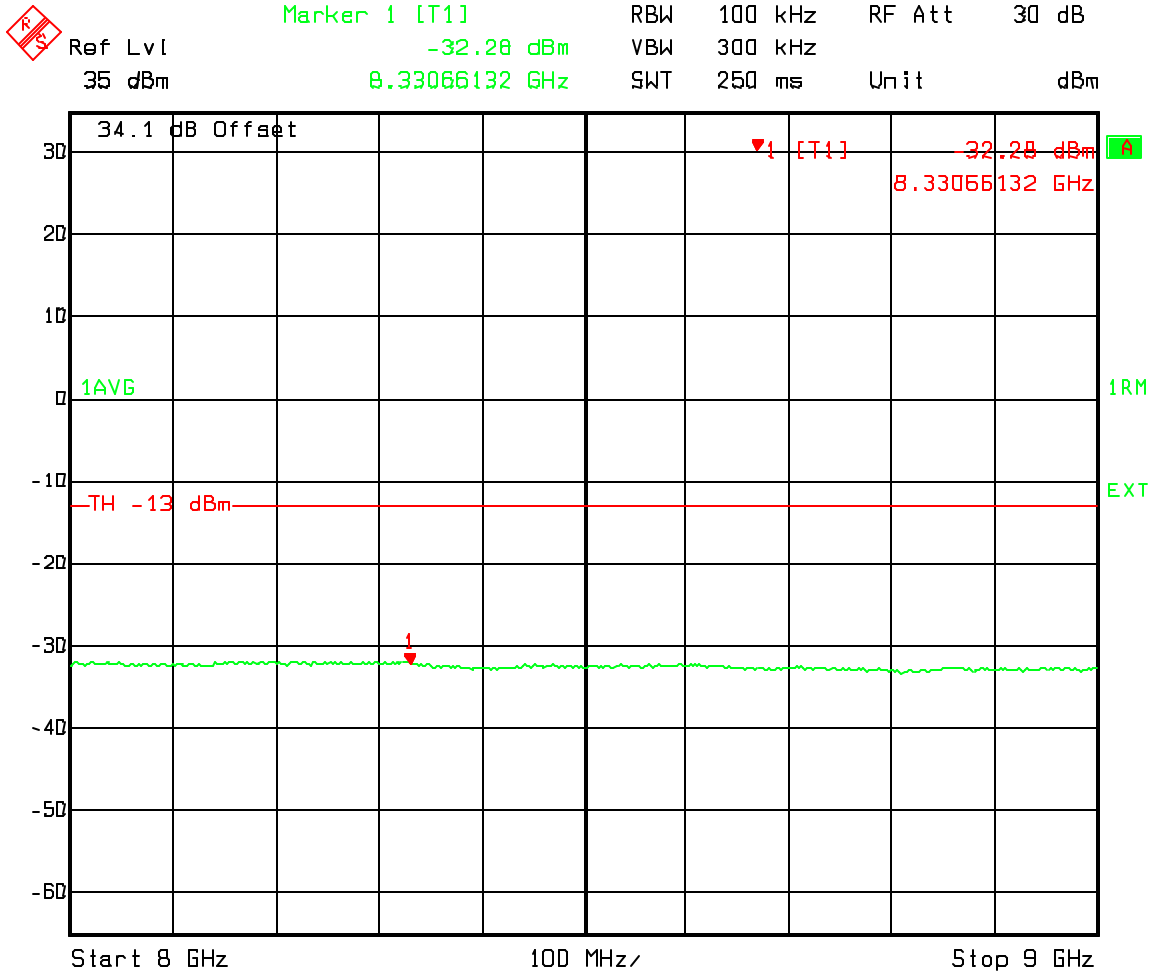

Date: 21.JAN.2004 20:56:49

Three Channel 1015, 33, 73 and 226, 267, 308 Spurious Emissions at the 800 MHz MFRM2 Ant. Port Three Carrier band A and A'' IS856

A'' and A Band IS856 Spurious emissions 9000-10000 MHz

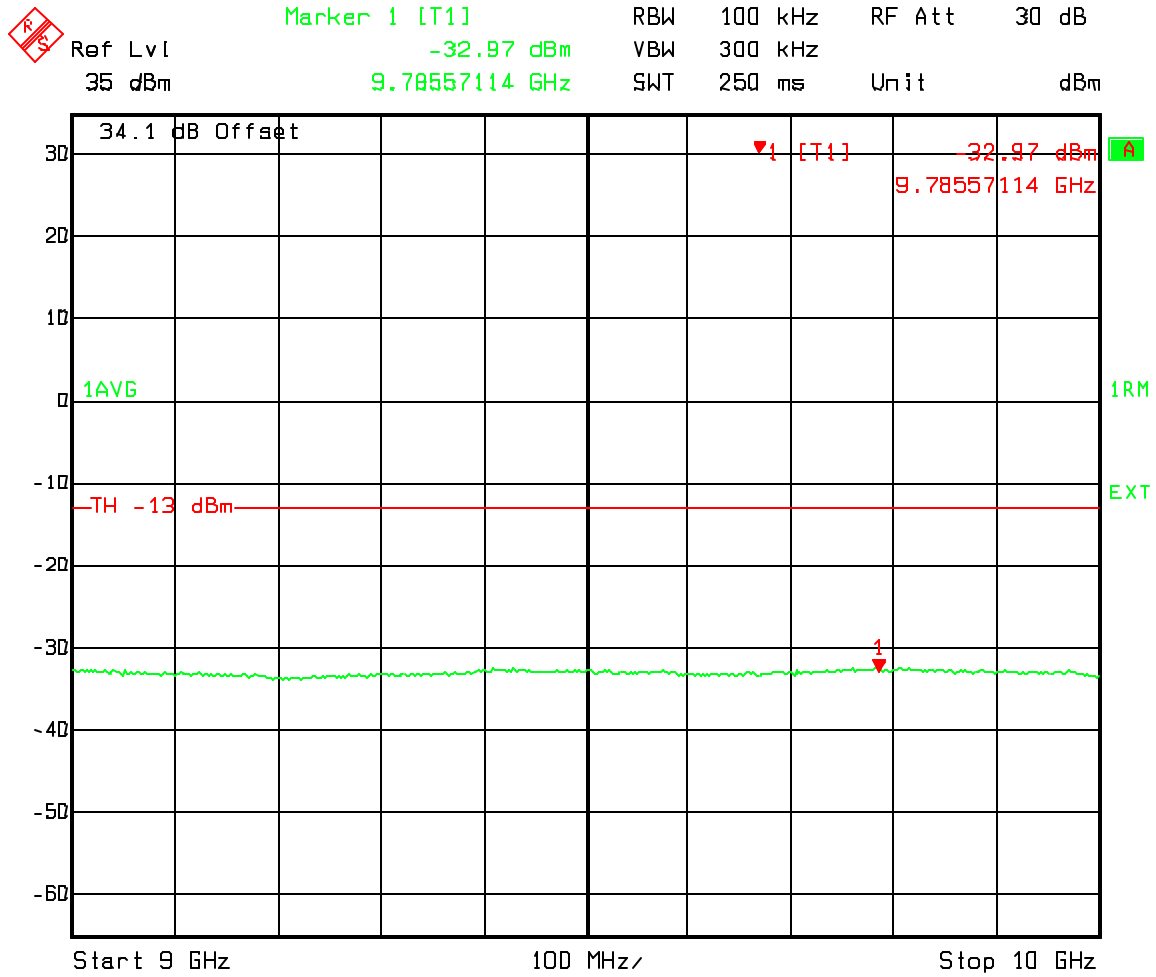

Date: 21.JAN.2004 20:57:49

Combination Three Carrier 1015 and 33 (IS856), 74 (IS95) Spurious Emissions at the 800 MHz MFRM2 Ant. Port band A and A''

Occupied Bandwidth Ch 1015, 33, 74, 74A''

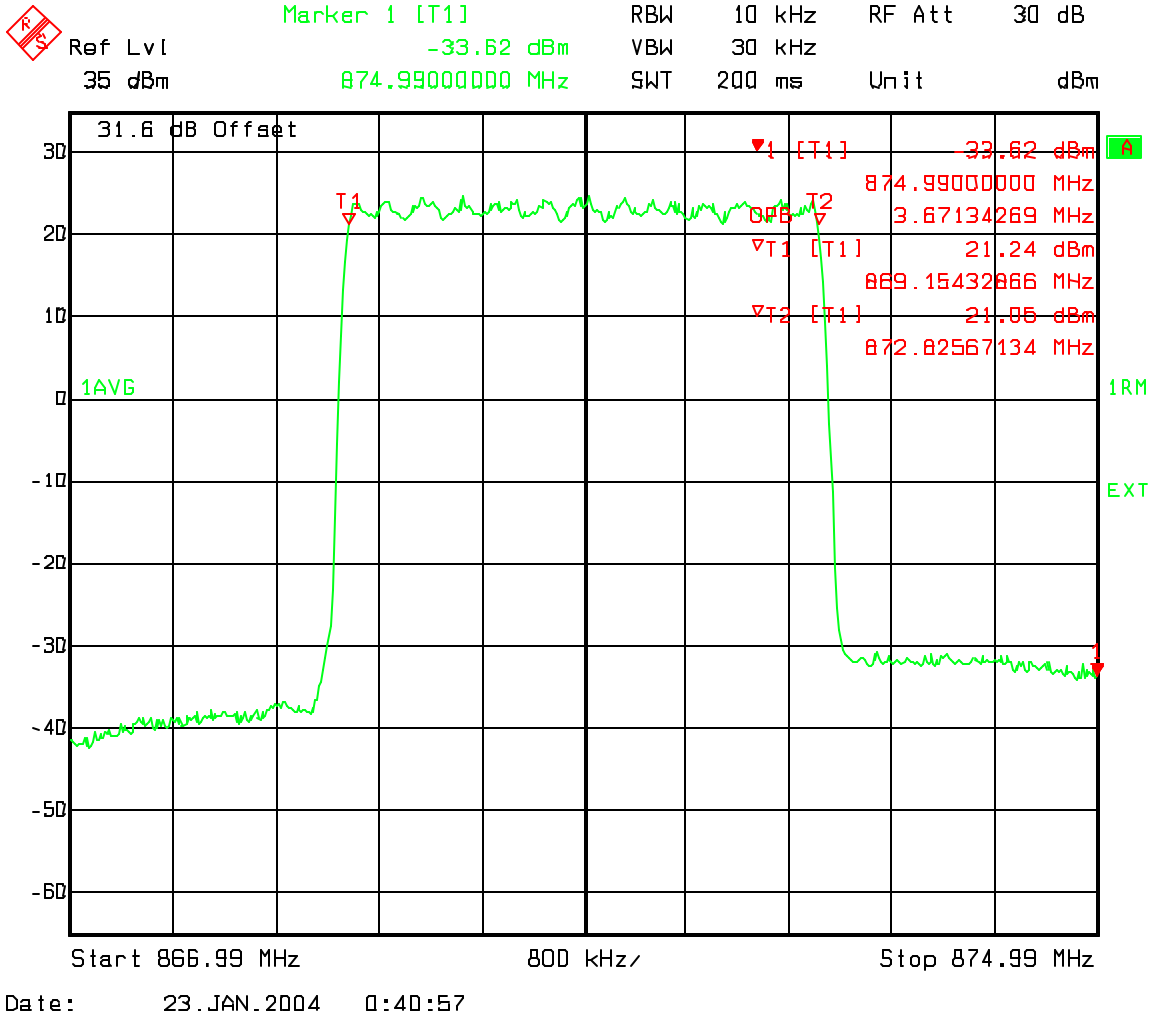

Combination Three Carrier 1015 and 33 (IS856), 74 (IS95) Spurious Emissions at the 800 MHz MFRM2 Ant. Port band A and A''

A'' Band Ch1015, 33, 74, 74 IS856/IS95 Channel power Adjacent 37.5 kHz Lower emissions to 869 MHz

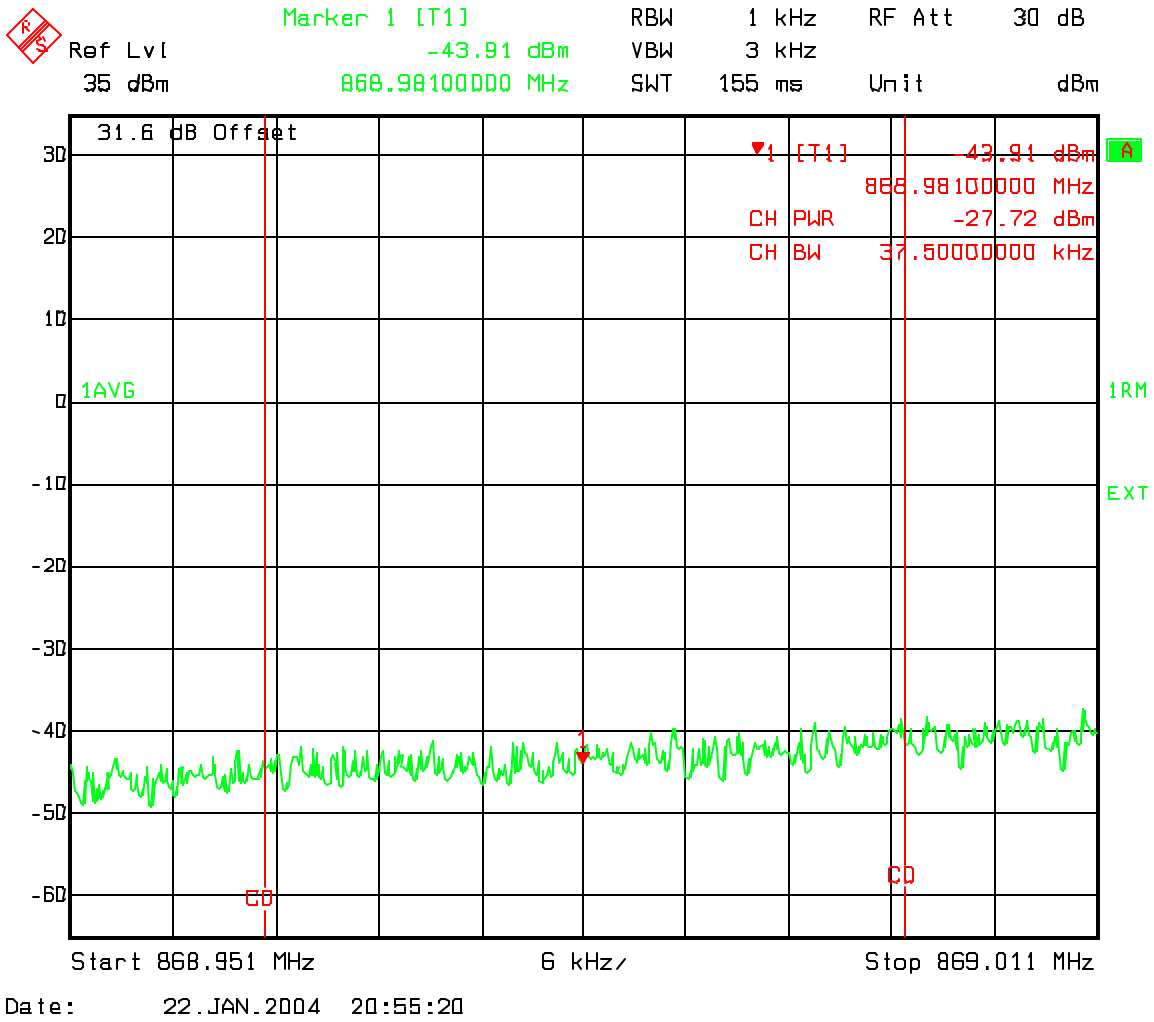

Combination Three Carrier 1015 and 33 (IS856), 74 (IS95) Spurious Emissions at the 800 MHz MFRM2 Ant. Port band A and A''

Ch1015, 33, 74, 74 Upper A Band adjacent 1MHz band emissions

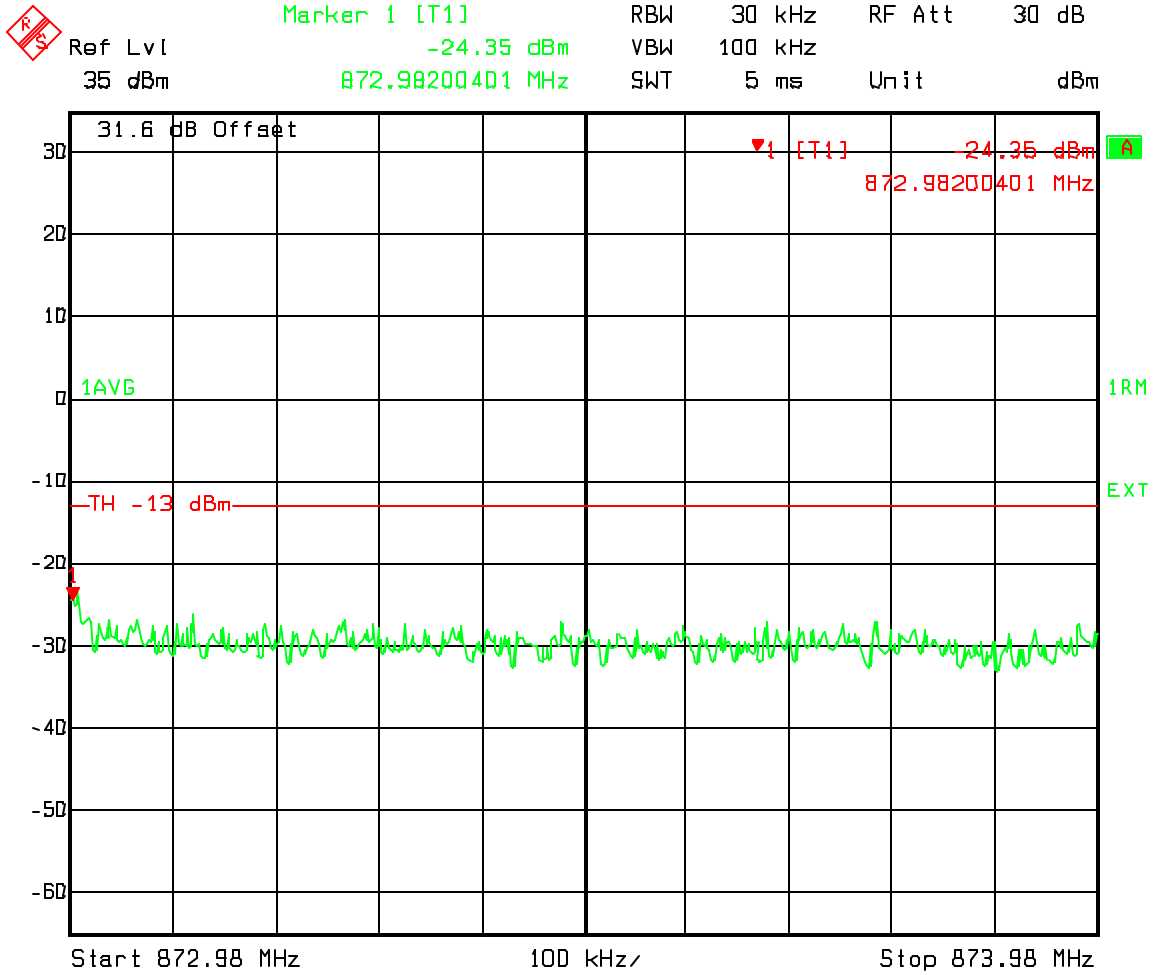

Date: 22.JAN.2004 20:56:15

Combination Three Carrier 1015 and 33 (IS856), 74 (IS95) Spurious Emissions at the 800 MHz MFRM2 Ant. Port band A and A''

Ch1015, 33, 74, 74 Upper adjacent 1MHz band 37.5 kHz band Channel power

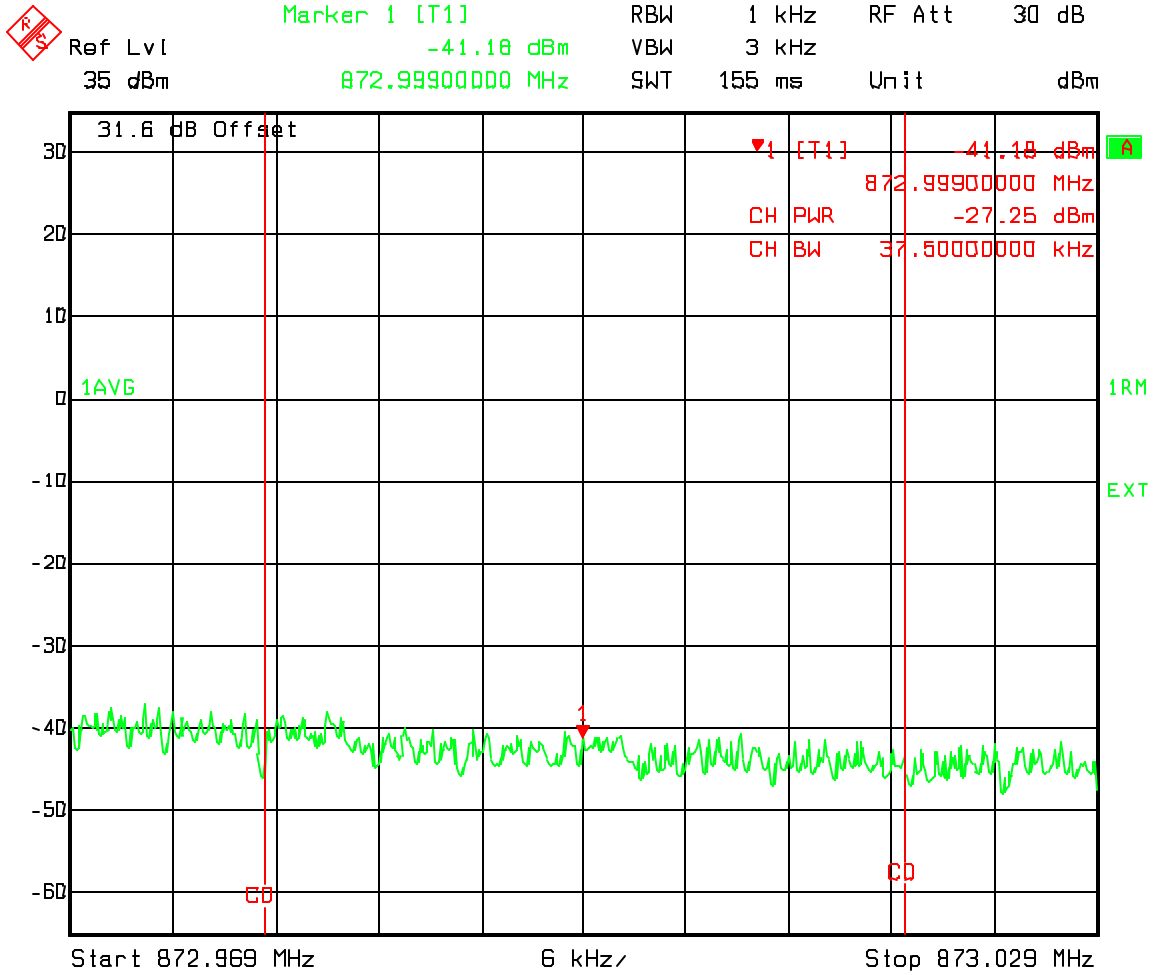

Date: 22.JAN.2004 20:57:10

Combination Three Carrier 1015 and 33 (IS856), 74 (IS95) Spurious Emissions at the 800 MHz MFRM2 Ant. Port band A and A''

Industry Canada Lower 750 kHz offset 30kHz Chan Power Ch 1015, 33, 74

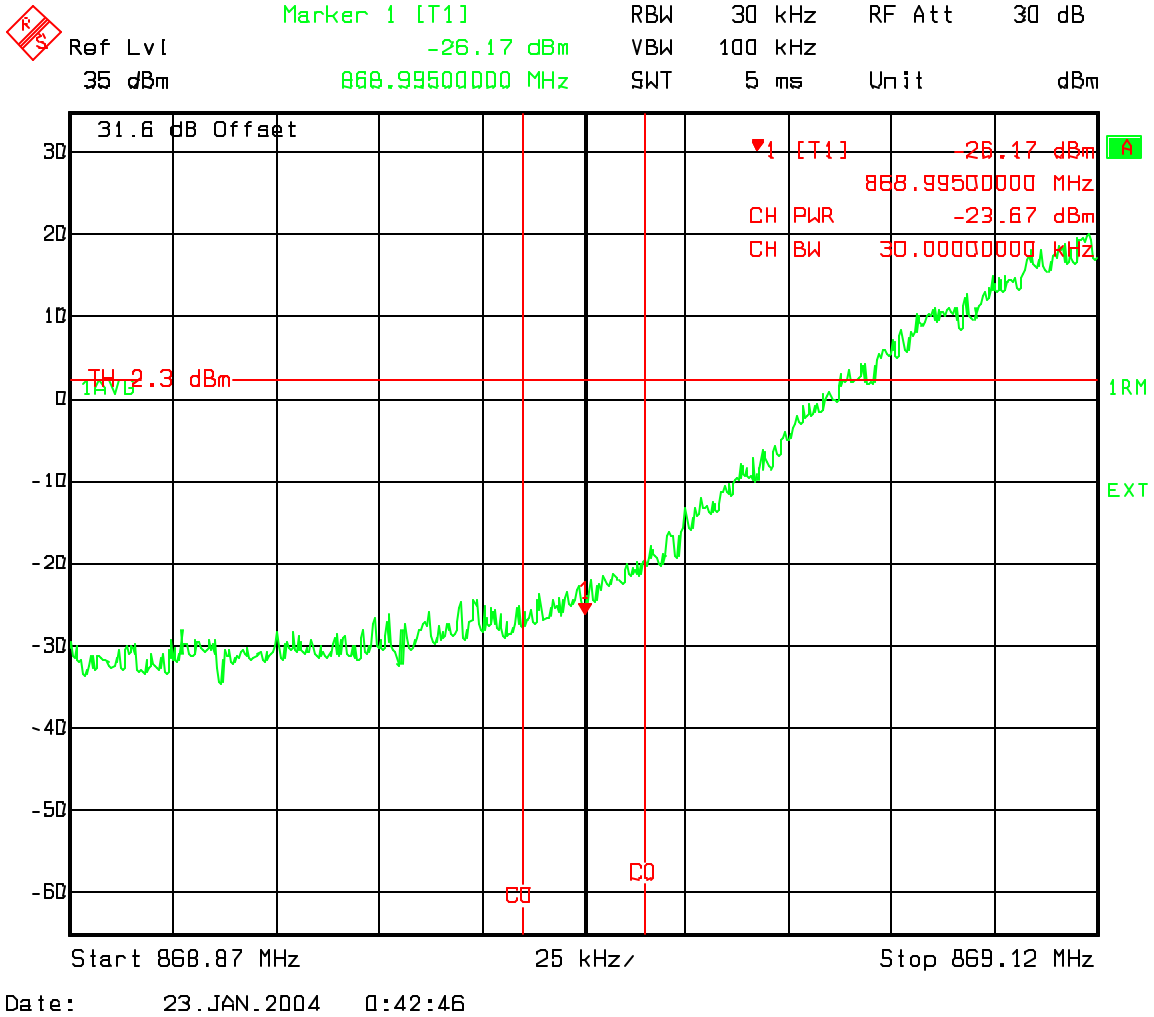

Combination Three Carrier 1015 and 33 (IS856), 74 (IS95) Spurious Emissions at the 800 MHz MFRM2 Ant. Port band A and A''

Industry Canada Upper 750 kHz offset 30kHz Chan Power Ch 1015, 33, 74,74

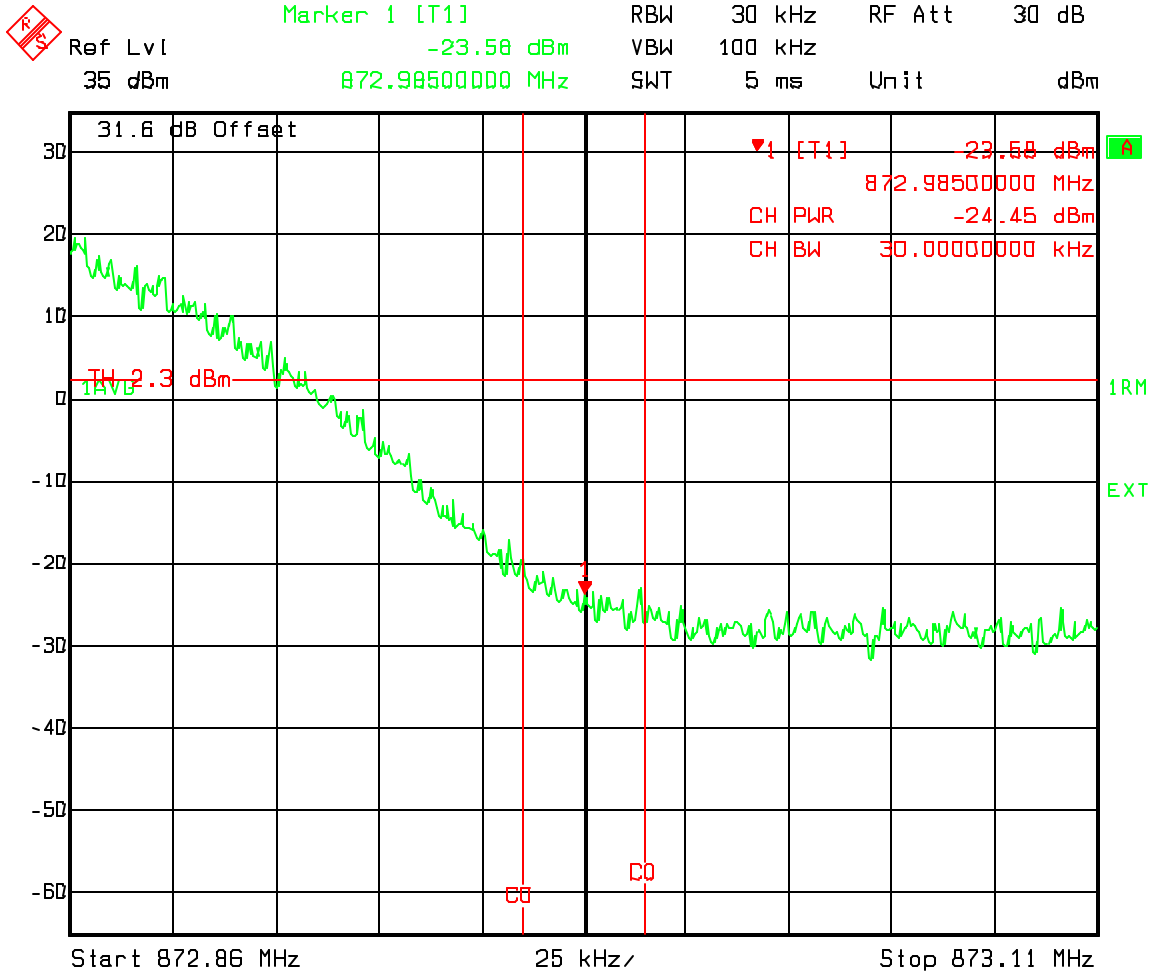

Date: 23.JAN.2004 0:43:40

Combination Three Carrier 1015 and 33 (IS856), 74 (IS95) Spurious Emissions at the 800 MHz MFRM2 Ant. Port band A and A''

Industry Canada 1.98 MHz offset Lower 30kHz Chan Power Ch 1015, 33, 74

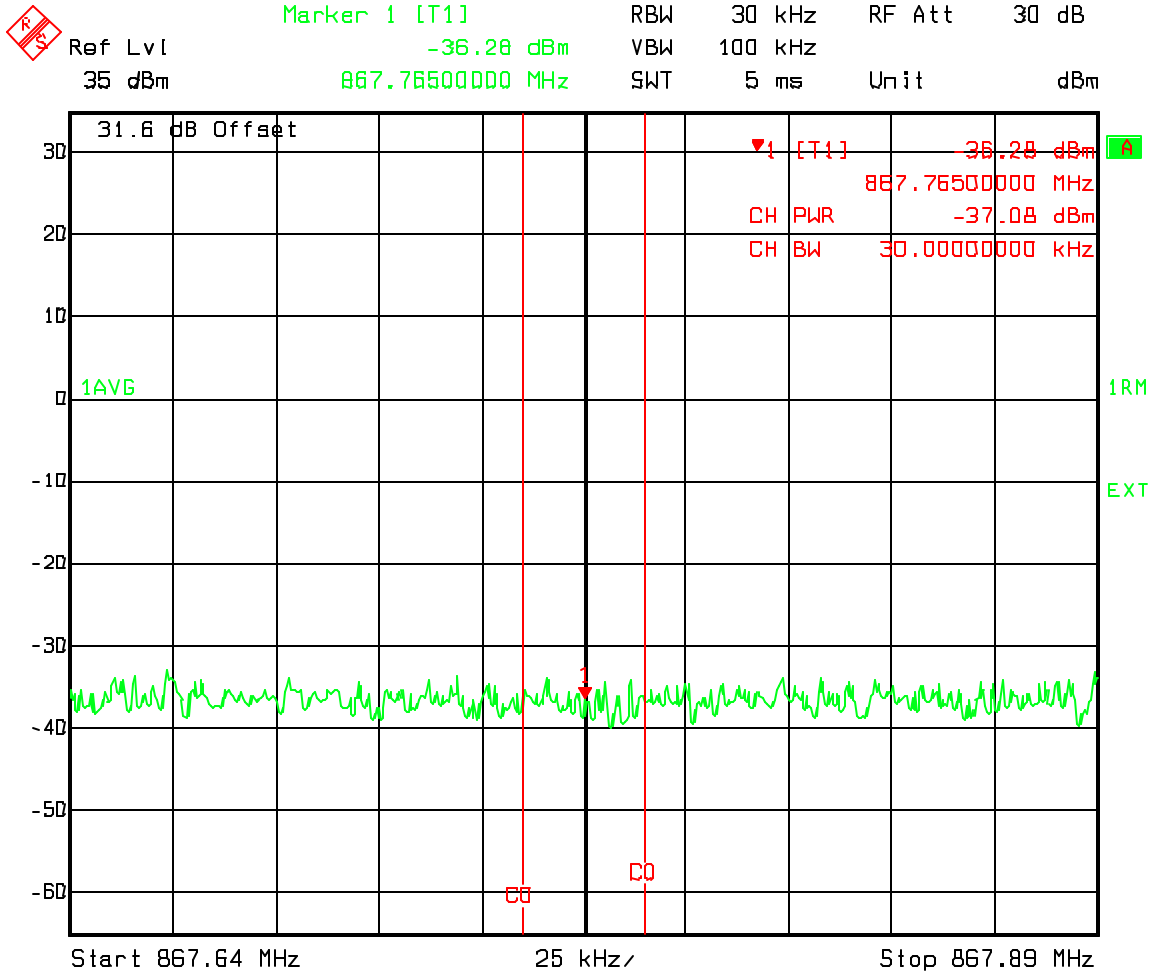

Date: 23.JAN.2004 0:44:35

Combination Three Carrier 1015 and 33 (IS856), 74 (IS95) Spurious Emissions at the 800 MHz MFRM2 Ant. Port band A and A''

Industry Canada 1.98 MHz offset Upper 30kHz Chan Power Ch 1015, 33, 74

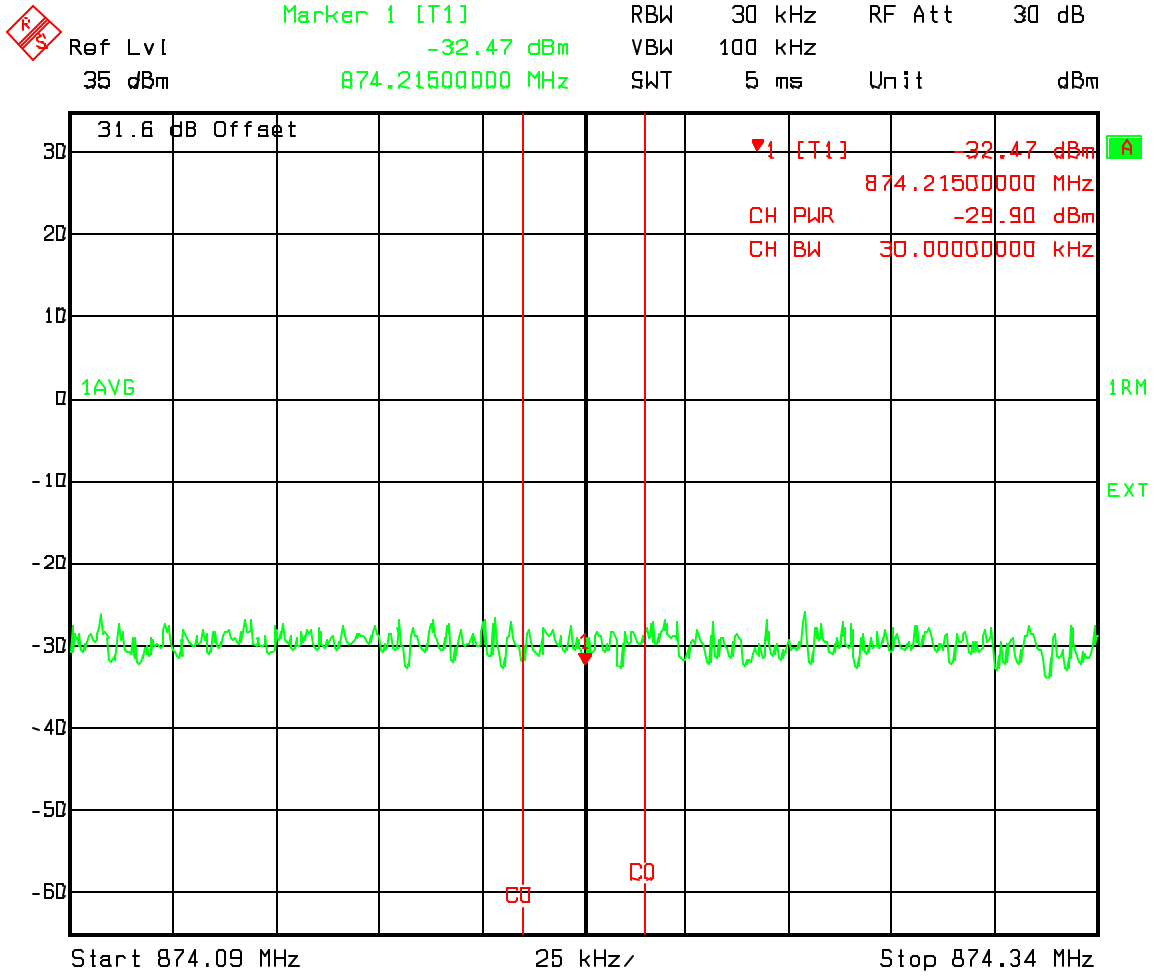

Date: 23.JAN.2004 0:45:30

Combination Three Carrier 1015 and 33 (IS856), 74 (IS95) Spurious Emissions at the 800 MHz MFRM2 Ant. Port band A and A''

A'' and A Band IS856/IS95 Spurious emissions 10kHz-400 MHz

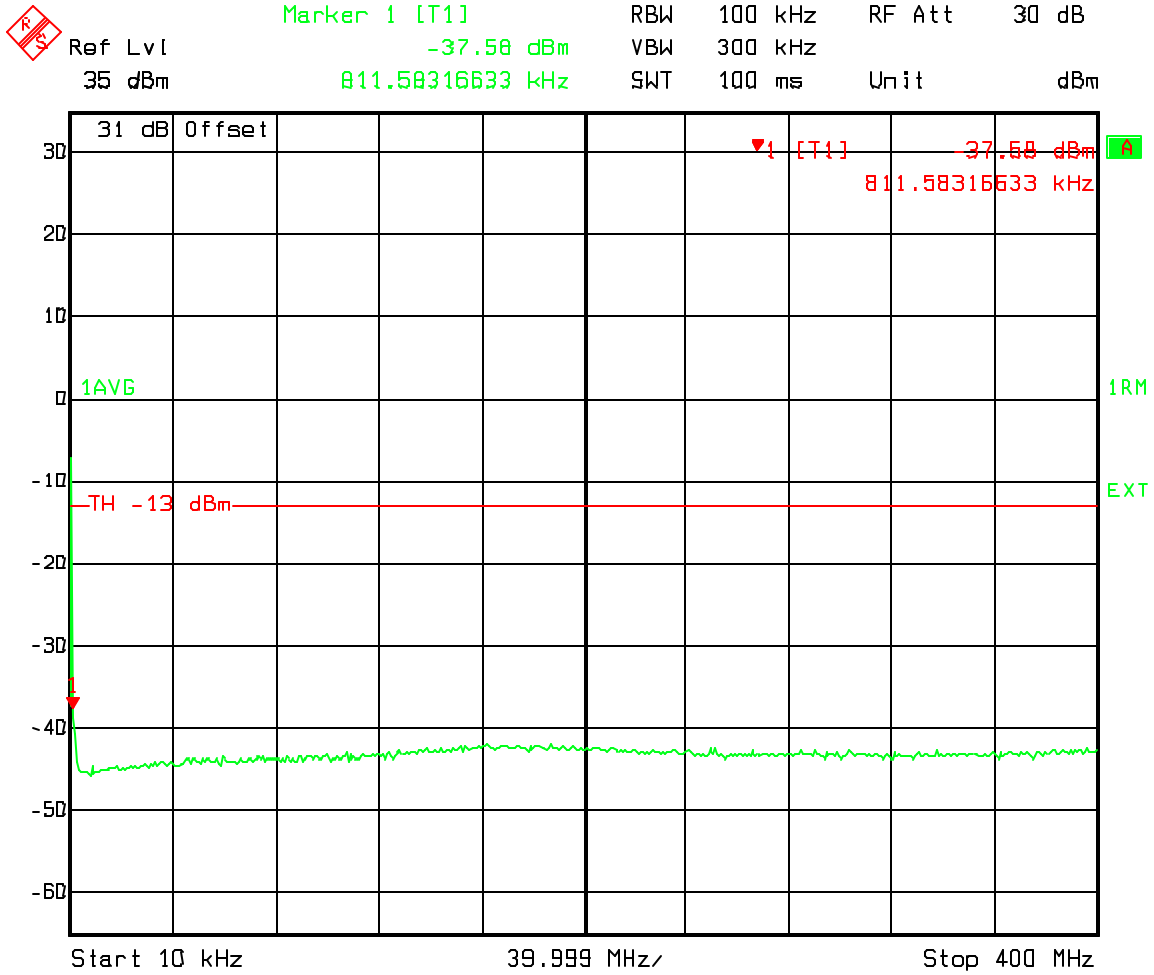

Date: 22.JAN.2004 20:58:06

Combination Three Carrier 1015 and 33 (IS856), 74 (IS95) Spurious Emissions at the 800 MHz MFRM2 Ant. Port band A and A''

A'' and A Band IS856/IS95 Spurious emissions 400MHz to Lower 1MHz Band Edge

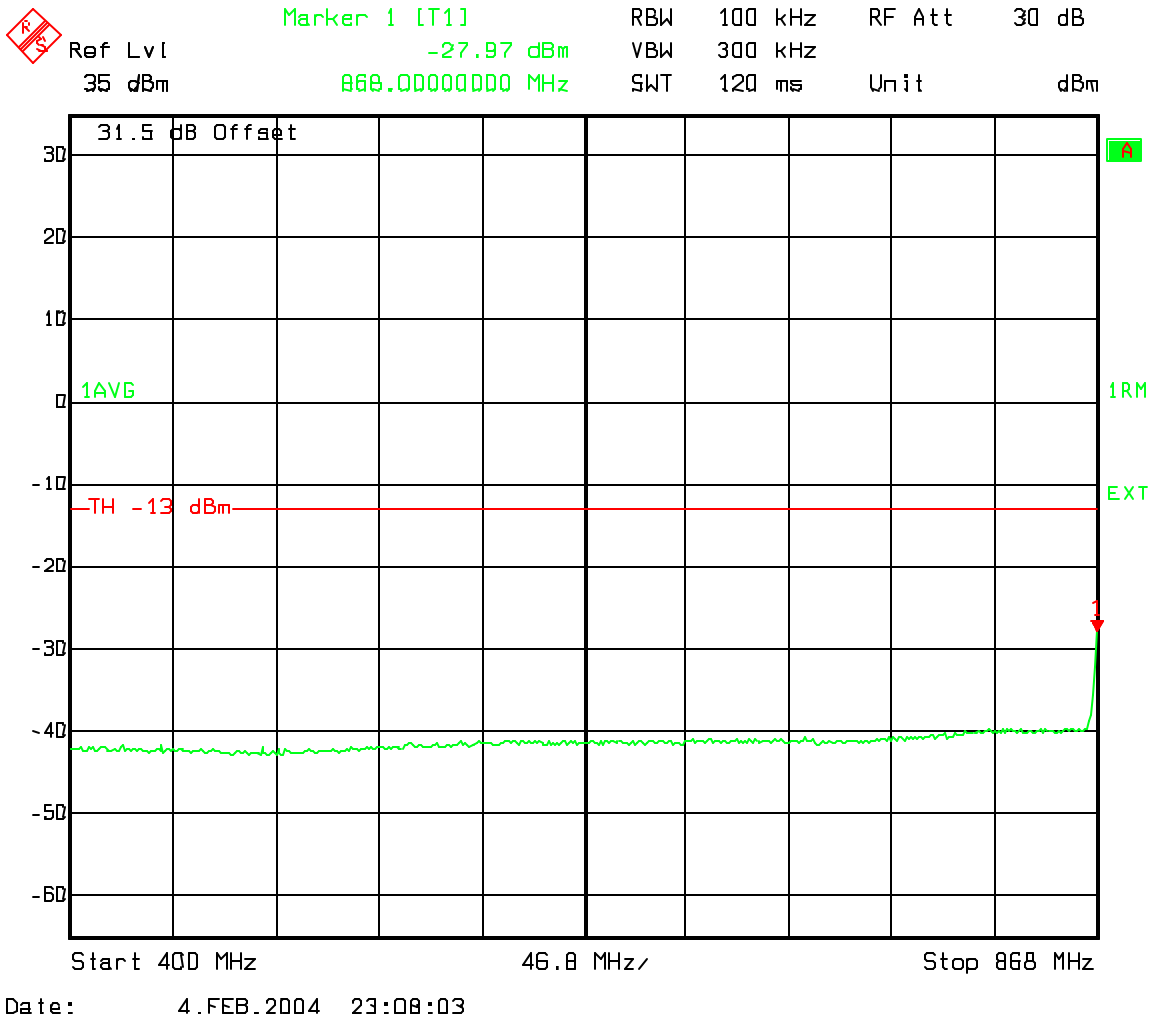

Combination Three Carrier 1015 and 33 (IS856), 74 (IS95) Spurious Emissions at the 800 MHz MFRM2 Ant. Port band A and A''

A'' and A Band IS856/IS95 Spurious emissions Upper 1MHz Band Edge to 1GHz

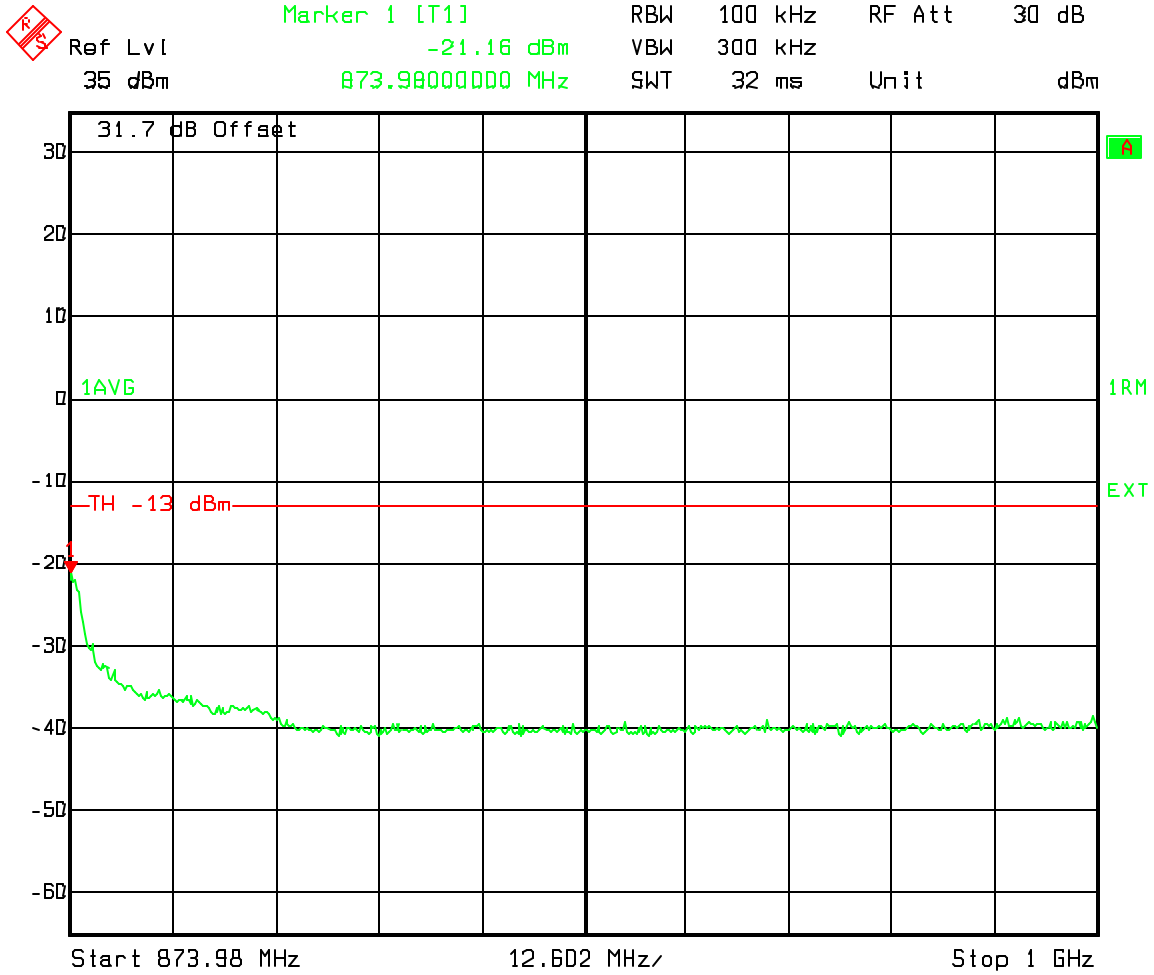

Date: 4.FEB.2004 23:08:57

Combination Three Carrier 1015 and 33 (IS856), 74 (IS95) Spurious Emissions at the 800 MHz MFRM2 Ant. Port band A and A''

A'' and A Band IS856/IS95 Spurious emissions 400-1000 MHz

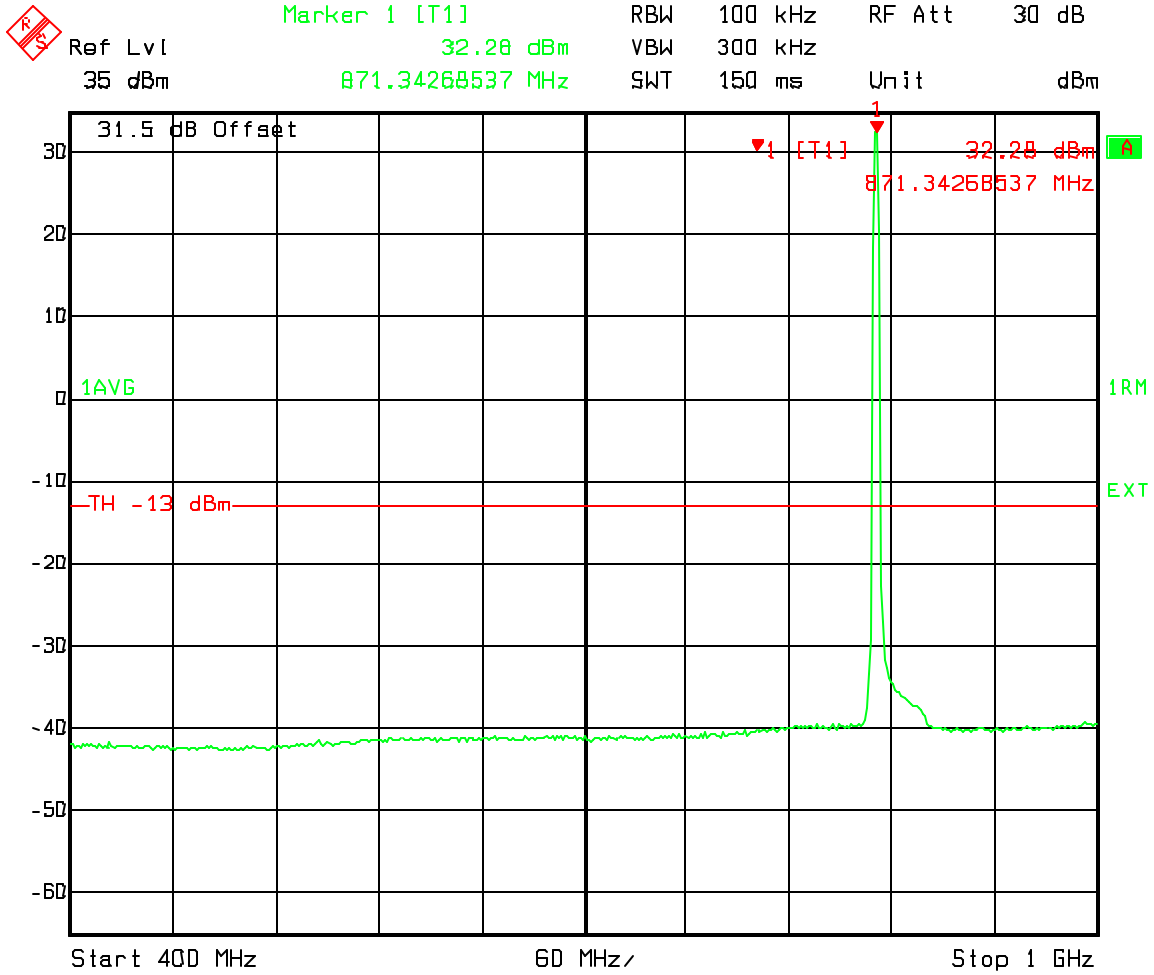

Date: 22.JAN.2004 20:59:00

Combination Three Carrier 1015 and 33 (IS856), 74 (IS95) Spurious Emissions at the 800 MHz MFRM2 Ant. Port band A and A''

A'' and A Band IS856/IS95 Spurious emissions 1000-2000 MHz

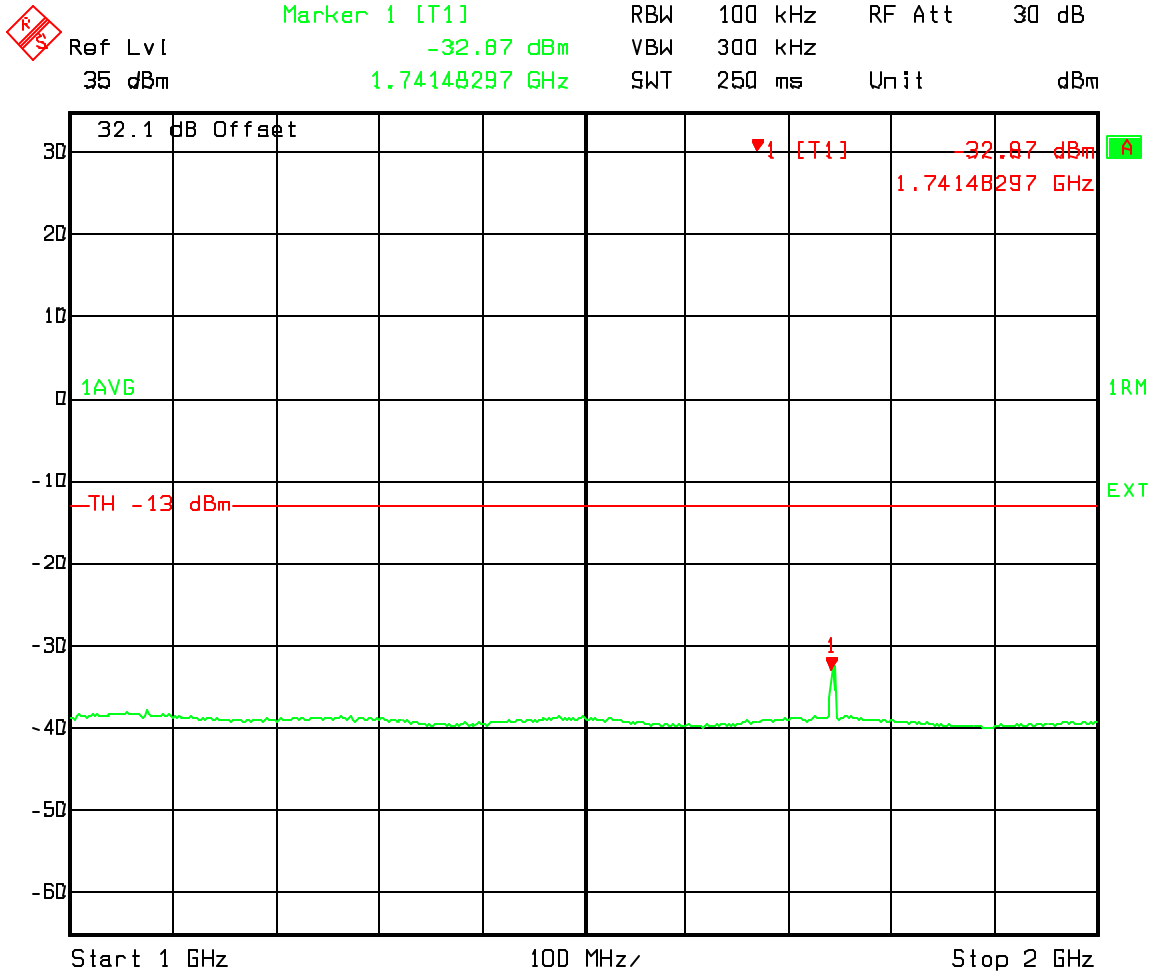

Date: 22.JAN.2004 20:59:52

Combination Three Carrier 1015 and 33 (IS856), 74 (IS95) Spurious Emissions at the 800 MHz MFRM2 Ant. Port band A and A''

A'' and A Band IS856/IS95 Spurious emissions 2000-3000 MHz

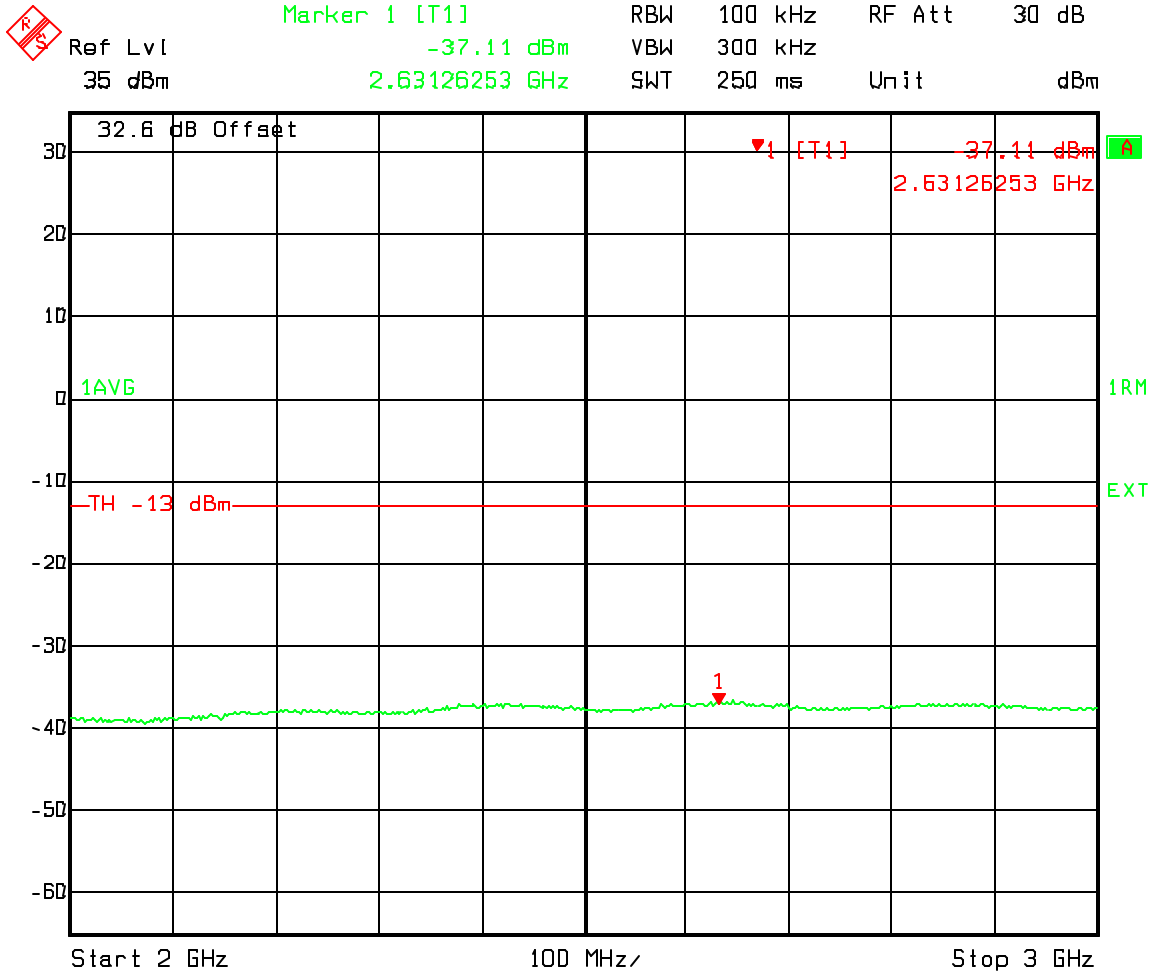

Date: 22.JAN.2004 21:00:47

Combination Three Carrier 1015 and 33 (IS856), 74 (IS95) Spurious Emissions at the 800 MHz MFRM2 Ant. Port band A and A''

A'' and A Band IS856/IS95 Spurious emissions 3000-4000 MHz

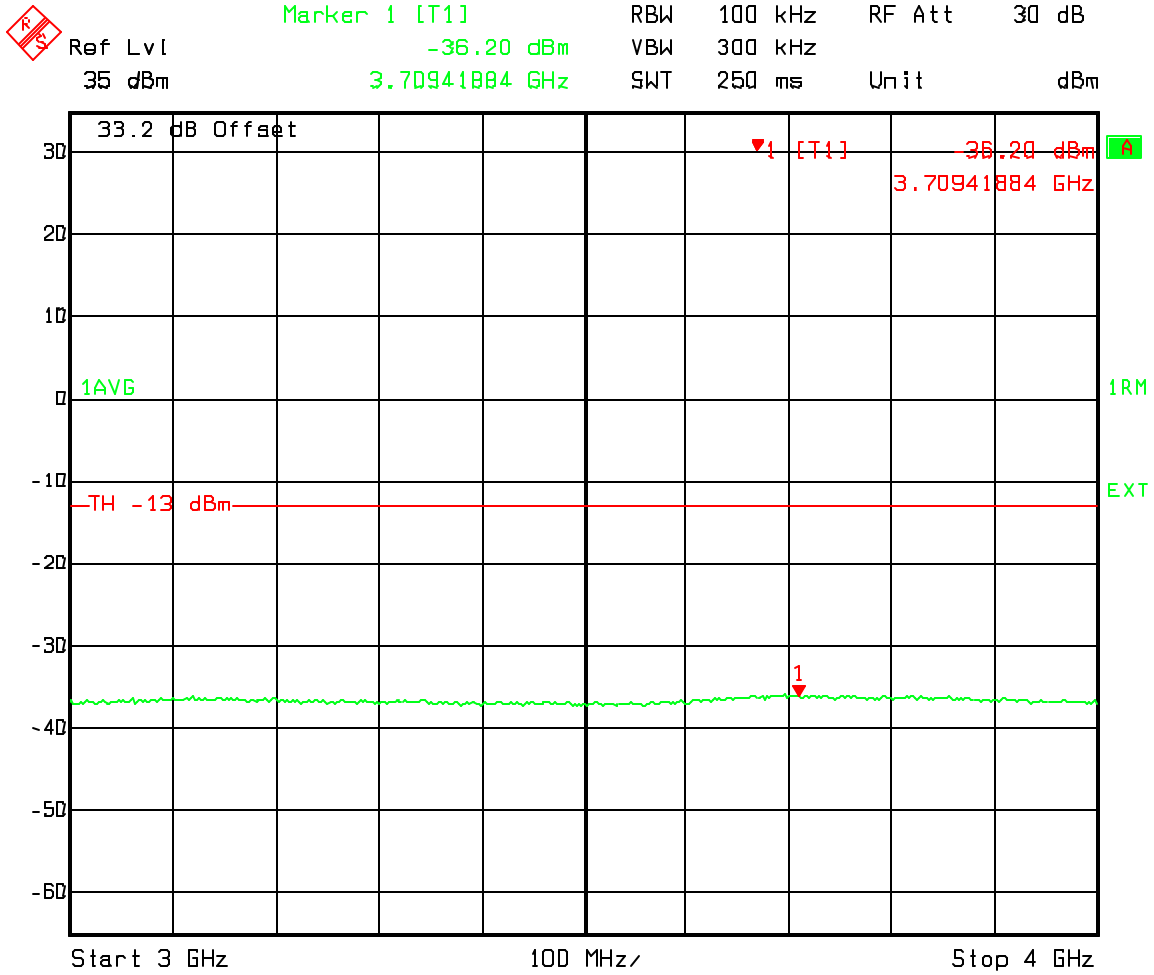

Date: 22.JAN.2004 21:01:40

Combination Three Carrier 1015 and 33 (IS856), 74 (IS95) Spurious Emissions at the 800 MHz MFRM2 Ant. Port band A and A''

A'' and A Band IS856/IS95 Spurious emissions 4000-5000 MHz

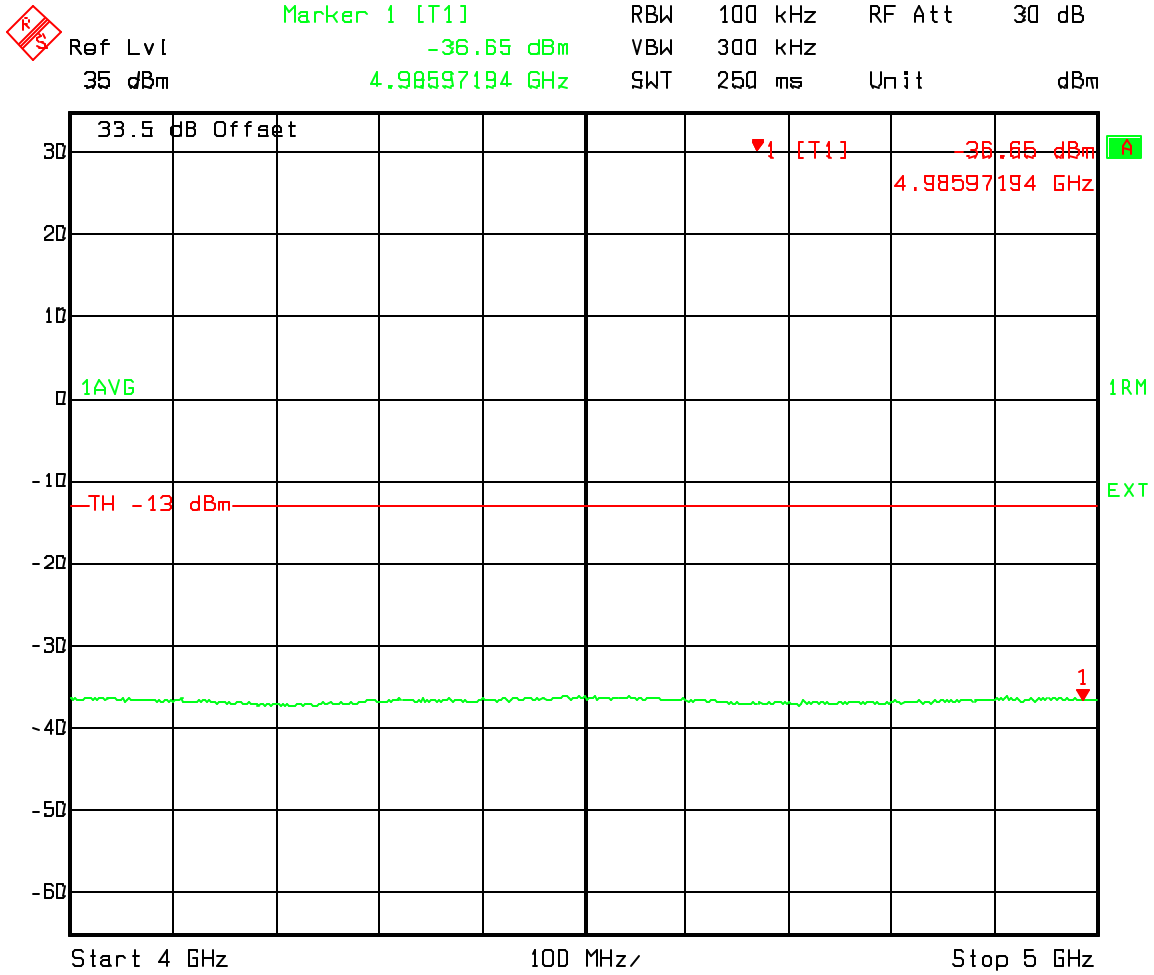

Date: 22.JAN.2004 21:02:34

Combination Three Carrier 1015 and 33 (IS856), 74 (IS95) Spurious Emissions at the 800 MHz MFRM2 Ant. Port band A and A''

A'' and A Band IS856/IS95 Spurious emissions 5000-6000 MHz

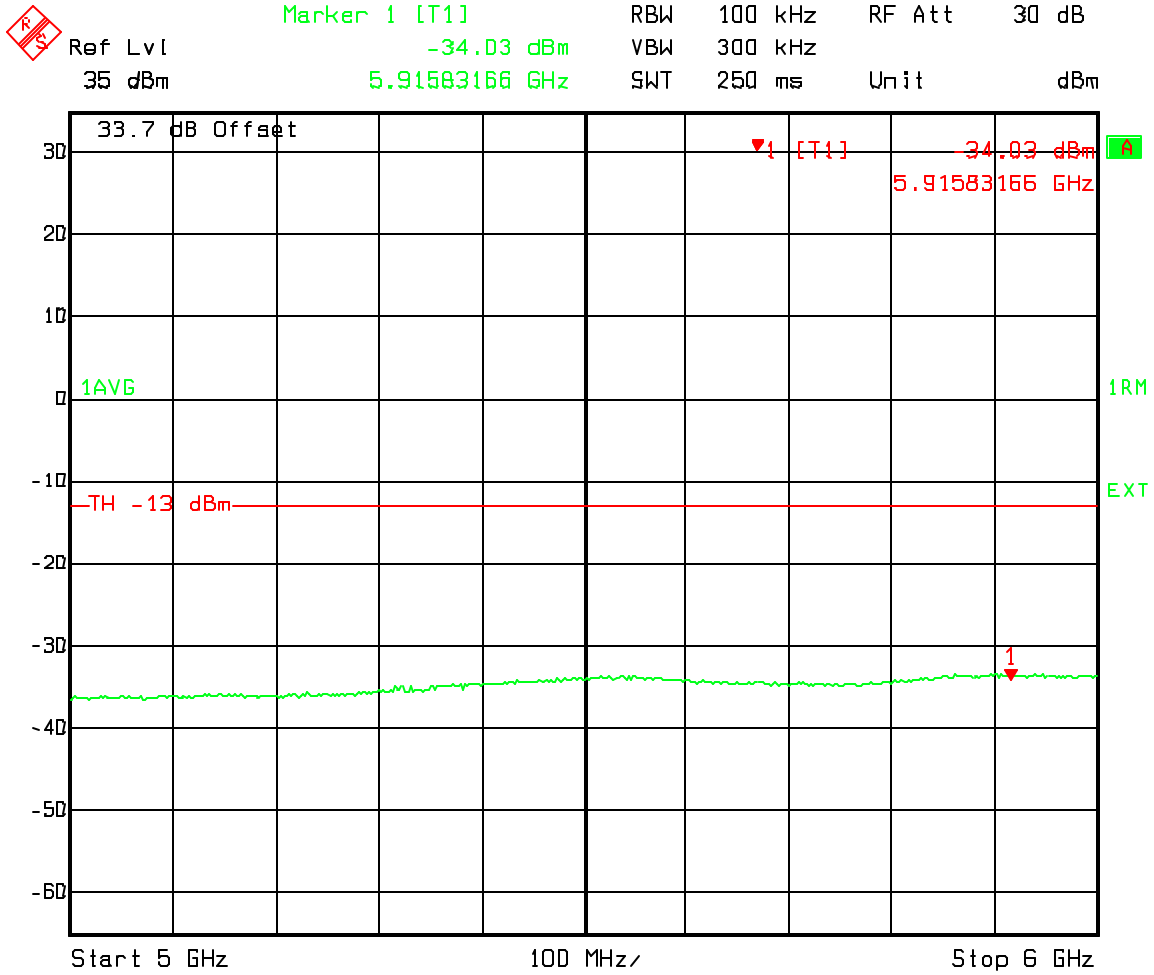

Date: 22.JAN.2004 21:03:29

Combination Three Carrier 1015 and 33 (IS856), 74 (IS95) Spurious Emissions at the 800 MHz MFRM2 Ant. Port band A and A''

A'' and A Band IS856/IS95 Spurious emissions 6000-7000 MHz

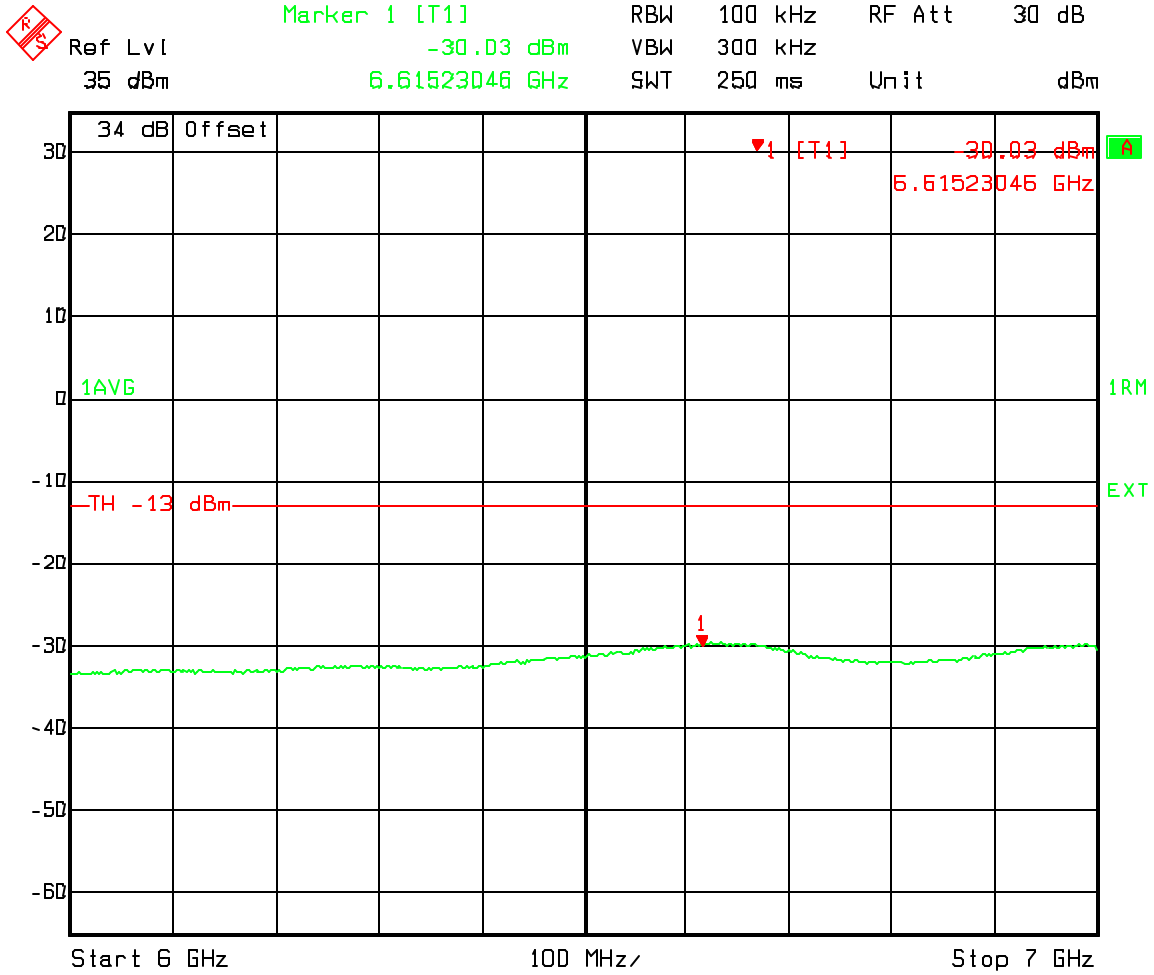

Date: 22.JAN.2004 21:04:21

Combination Three Carrier 1015 and 33 (IS856), 74 (IS95) Spurious Emissions at the 800 MHz MFRM2 Ant. Port band A and A''

A'' and A Band IS856/IS95 Spurious emissions 7000-8000 MHz

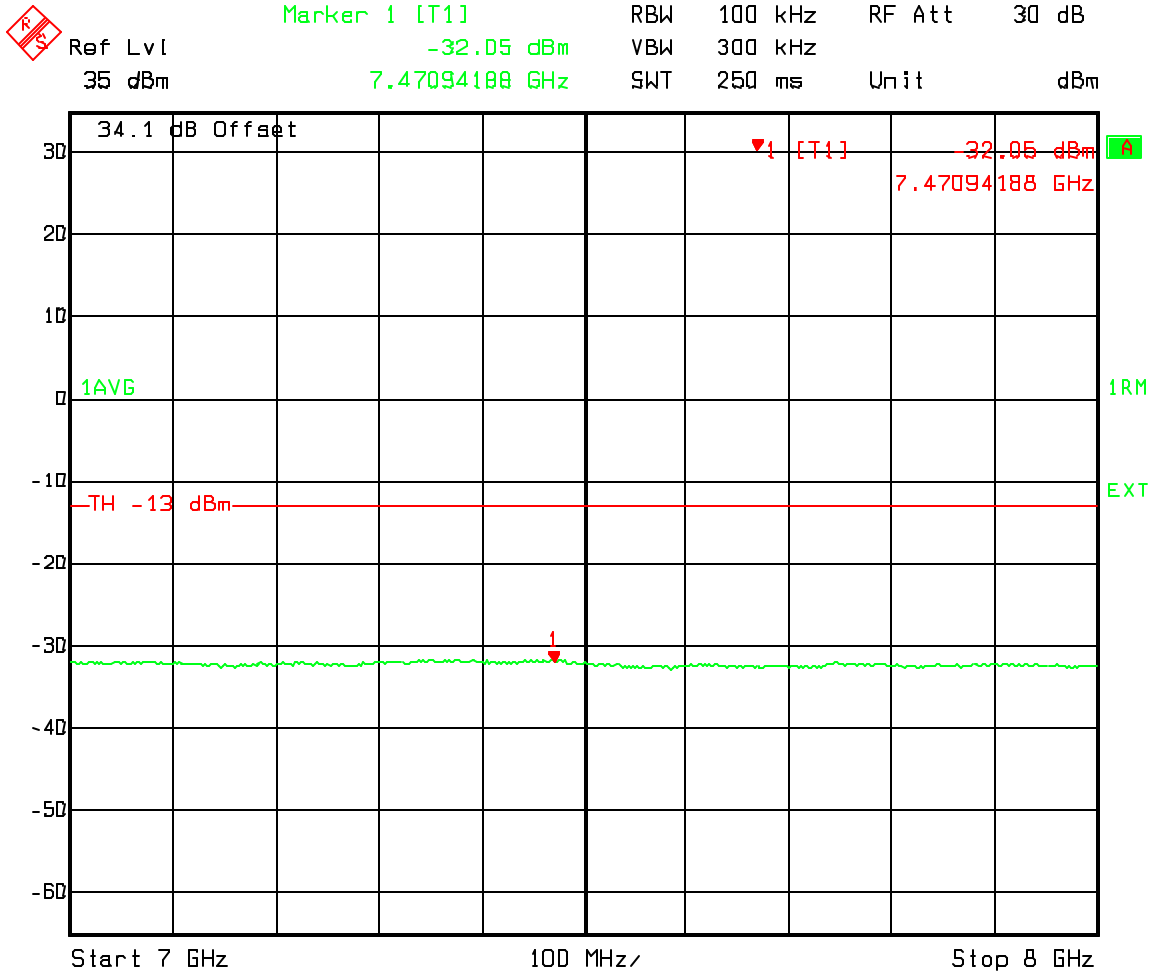

Date: 22.JAN.2004 21:05:18

Combination Three Carrier 1015 and 33 (IS856), 74 (IS95) Spurious Emissions at the 800 MHz MFRM2 Ant. Port band A and A''

A'' and A Band IS856/IS95 Spurious emissions 8000-9000 MHz

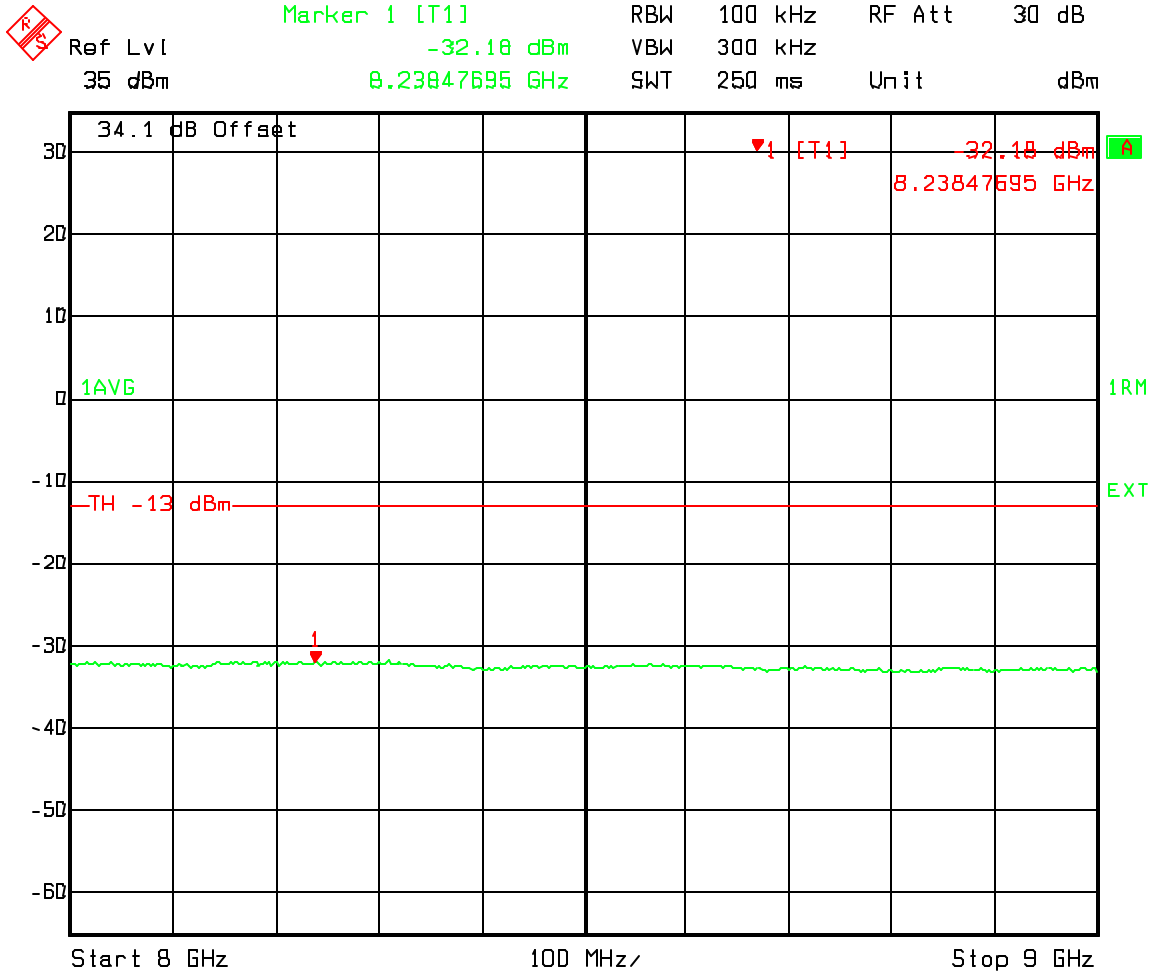

Date: 22.JAN.2004 21:06:13

Combination Three Carrier 1015 and 33 (IS856), 74 (IS95) Spurious Emissions at the 800 MHz MFRM2 Ant. Port band A and A''

A'' and A Band IS856/IS95 Spurious emissions 9000-10000 MHz

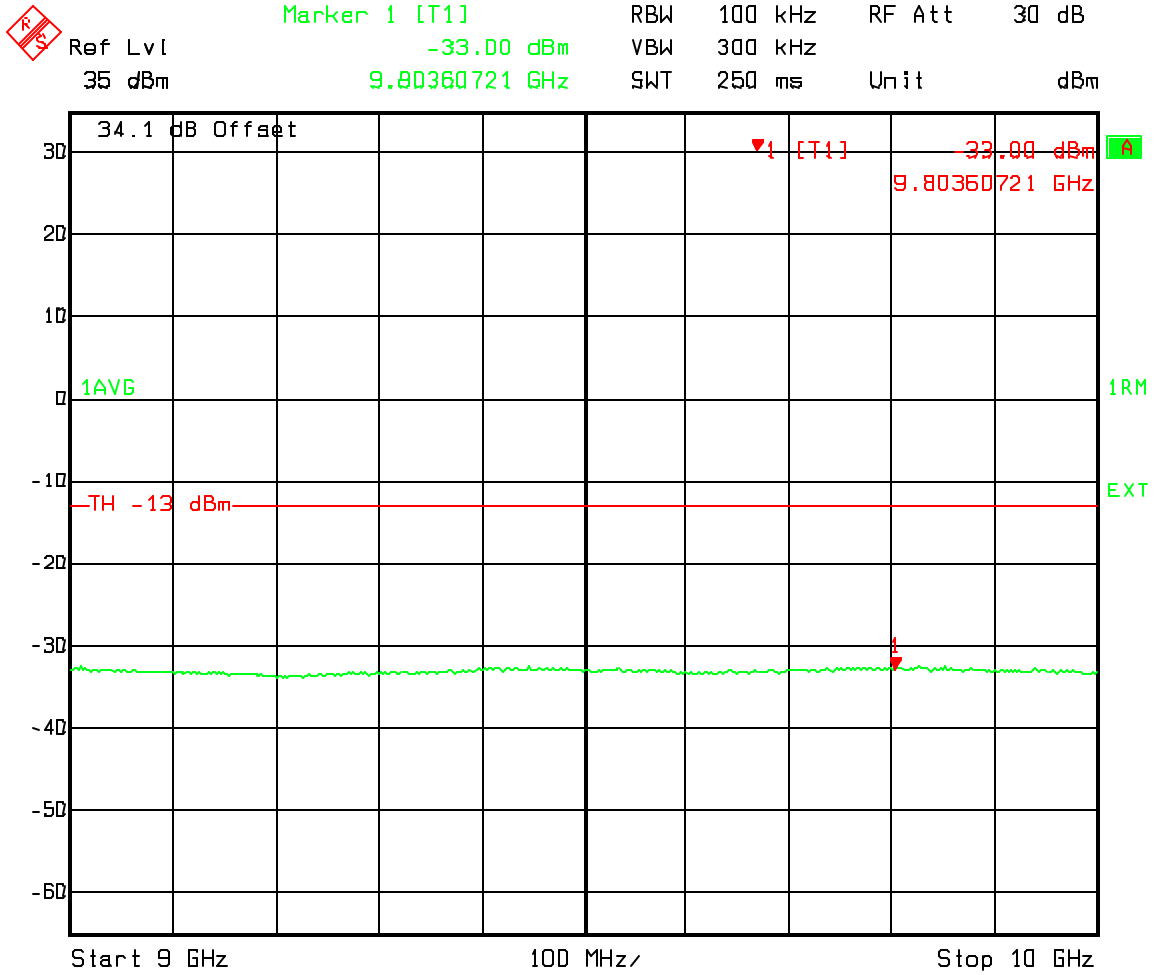

Date: 22.JAN.2004 21:07:09