



## **EXHIBIT 2B**

### **CE Test Report#2 Provided by Nortel Networks**

**Applicant: Nortel Networks**

**For Class II Permissive Change  
Certification on:**

**FCC ID: AB6NT800MFRM  
IC ID: 332292158**



---

## Test Report for FCC Equipment Authorization

FCC ID AB6NT800MFRM

**Document:** TR\_AB6NT800MFRM-MAPLE-CR  
**Stream:** 00  
**Issue:** 00.04  
**Document Status:** Approval  
**Issue Date:** July 15, 2004  
**Security Status:** Nortel Networks Confidential  
**Author:** Tuan Tran

---

© 2004 Nortel Networks Limited

### Disclaimer

The master of this document is stored on an electronic database and "write protected". The protection can be altered by authorized persons only. Viewing of the master document electronically ensures access to the current issue. Any hardcopies must be regarded as uncontrolled copies.

### Security Warning

The information disclosed herein is proprietary to Nortel Networks and not to be used by or disclosed by unauthorized persons without the written consent of Nortel Networks. The recipient of this document shall respect the security status of the information.

---

PAGE INTENTIONALLY LEFT BLANK

## Table of Contents

<b>Publication History .....</b>	<b>13</b>
List of Consultants .....	13
Decision Maker .....	13
Decision Ratifier .....	13
Revision History .....	14
<b>Acronyms and Abbreviations .....</b>	<b>15</b>
<b>1 Introduction.....</b>	<b>17</b>
1.1 Required Tests .....	17
<b>2 Engineering Declaration.....</b>	<b>18</b>
<b>3 Equipment Authorization Application Requirements .....</b>	<b>19</b>
3.1 Standard Test Conditions and Test Equipment.....	19
3.2 EUT Identification List.....	19
3.3 Test Equipment List.....	20
<b>4 Transmitter Tests.....</b>	<b>21</b>
4.1 RF Power Output .....	21
4.1.1 RF Power Output Requirements .....	21
4.1.1 FCC Part 2.1046 Measurements required: RF power output.....	21
4.1.2 Test Method .....	21
4.1.3 Test Setup .....	21
4.1.4 IS-95.....	21
4.1.5 DOM .....	21
4.1.6 Noise Floor .....	22
4.1.7 RF Output Power Test Results.....	23
4.2 Occupied Bandwidth.....	25
4.2.1 Occupied Bandwidth Requirements .....	25
4.2.1 FCC Part 2.1049 .....	25
4.2.2 Test Method .....	25
4.2.3 Test Setup .....	25
4.2.4 Test Result .....	26
4.3 Spurious Emissions at Antenna Terminals .....	29
4.3.1 Spurious Emissions Requirements.....	29
4.3.1 FCC Part 2.1051 .....	29
4.3.1 FCC Part 2.1057 - Frequency Spectrum to be investigated.....	29
4.3.1 FCC Part 22.917 Limit.....	29
4.3.2 Test Method .....	30
4.3.2.1 Adjacent 1MHz to indicated cellular band (Upper and Lower) .....	30
4.3.2.2 All other Spurious Emissions up to 10 GHz.....	31
4.3.3 Test Requirements .....	31
4.3.4 Test Setup .....	32
4.3.5 Test Results .....	33
4.4 Transmitter Tests (CDMA Mode) .....	43

---

4.4 Unwanted Emissions.....	43
4.4 IC RSS-129 .....	43
4.4.1 Test Method .....	43
4.4.1.1 Adjacent 1MHz to indicated cellular band (Upper and Lower) .....	44
4.4.2 Test Setup .....	45
4.4.3 Test Results.....	46
4.5 Frequency Stability .....	51
4.5.1 Frequency Stability Requirements.....	51
4.5.1 FCC Part 2.1055 .....	51
4.5.2 Test Procedure .....	52
4.5.3 Frequency Results.....	52
<b>5 Appendix A - Single Carrier IS-95 Spurious Emission .....</b>	<b>55</b>
<b>6 Appendix B - Two Carriers IS-95 Spurious Emission.....</b>	<b>77</b>
<b>7 Appendix C - Three Carrier IS-95 Spurious Emission .....</b>	<b>99</b>
<b>8 Appendix D - One Carrier IS-856 16QAM Spurious Emission.....</b>	<b>121</b>
<b>9 Appendix E - Three Carriers IS-856 16 QAM Spurious Emission .....</b>	<b>143</b>
<b>10 Appendix F - Combined Three Carrier: 2-IS856 (358,399), 1-IS95 (440) Spurious Emission.....</b>	<b>166</b>
<b>References.....</b>	<b>189</b>

## List of Figures

Figure 1 : Test Setup for RF Power Output Measurement .....	22
Figure 2 : Test Setup for Occupied Bandwidth Measurement.....	26
Figure 3 : Test Setup for Spurious Emissions Measurement.....	32
Figure 4 : Test Setup for Spurious Emissions Measurement.....	45
Figure 5 : Test configuration for Frequency Stability .....	52
Figure 6 : 1 Carrier - Occupied Bandwidth Channel 1015 .....	55
Figure 7 : One Carrier - A ” Band Ch 1015 IS95 Adjacent 1 MHz Lower emissions 868-869 MHz 56	
Figure 8 : One Carrier - Ch1015 IS95 Lower A” Band Adjacent to outside edge 12.5kHz band Channel Power .....	57
Figure 9 : One Carrier - Ch 308 Upper A Band adjacent 1MHz band emissions.....	58
Figure 10 : One Carrier - Ch 308 Upper A Band adjacent to outside edge 12.5 kHz band Channel power .....	59
Figure 11 : One Carrier - Industry Canada Lower 750 kHz offset 30 kHz Chan Power Ch 1015 ... 60	
Figure 12 : One Carrier - Industry Canada Upper 750 kHz offset 30 kHz Chan Power Ch 101561	
Figure 13 : One Carrier - Industry Canada 1.98 MHz offset Lower 30 kHz Chan Power Ch 1015. 62	
Figure 14 : One Carrier - Industry Canada 1.98 MHz offset Upper 30 kHz Chan Power Ch 1015 . 63	
Figure 15 : One Carrier - A ” and A Band IS95 Spurious emissions 10kHz-400 MHz .....	64
Figure 16 : One Carrier - A ” and a Band IS95 Spurious emissions 400 MHz to Lower 1 MHz Band Edge.....	65
Figure 17 : One Carrier - A ” and a Band IS95 Spurious emissions Upper 1 MHz Band Edge to 1 GHz.....	66
Figure 18 : One Carrier - A ” and A Band IS95 Spurious emissions 400-1000 MHz.....	67
Figure 19 : One Carrier - A ” and A Band IS95 Spurious emissions 1000-2000 MHz.....	68
Figure 20 : One Carrier - A ” and A Band IS95 Spurious emissions 2000-3000 MHz.....	69
Figure 21 : One Carrier - A ” and A Band IS95 Spurious emissions 3000-4000 MHz.....	70
Figure 22 : One Carrier - A ” and A Band IS95 Spurious emissions 4000-5000 MHz.....	71
Figure 23 : One Carrier - A ” and A Band IS95 Spurious emissions 5000-6000 MHz.....	72
Figure 24 : One Carrier - A ” and A Band IS95 Spurious emissions 6000-7000 MHz.....	73
Figure 25 : One Carrier - A ” and A Band IS95 Spurious emissions 7000-8000 MHz.....	74

Figure 26 : One Carrier - A'' and A Band IS95 Spurious emissions 8000-9000 MHz.....	75
Figure 27 : One Carrier - A'' and A Band IS95 Spurious emissions 9000-10000 MHz.....	76
Figure 28 : Two Carriers - Occupied Bandwidth Ch 358, 399 Band B.....	77
Figure 29 : Two Carriers - B Band Ch358, 399 IS95 Adjacent 1 MHz Lower emissions 879-880 MHz .....	78
Figure 30 : Two Carriers - Ch 358, 399 IS95 Lower B Band Adjacent to outside edge 25kHz band Channel Power .....	79
Figure 31 : Two Carriers - Ch 601, 642 Upper B Band adjacent 1 MHz band emissions 890-891 MHz .....	80
Figure 32 : Two Carriers - Ch 601, 642 Upper B Band adjacent to outside edge 25.0 kHz band Channel power .....	81
Figure 33 : Two Carriers - Industry Canada Lower 750 kHz offset 30 kHz Chan Power Ch 358, 399 .....	82
Figure 34 : Two Carriers - Industry Canada Upper 750 kHz offset 30 kHz Chan Power Ch 358, 399 .....	83
Figure 35 : Two Carriers - Industry Canada 1.98 MHz offset Lower 30 kHz Chan Power Ch 358, 399 .....	84
Figure 36 : Two Carriers - Industry Canada 1.98 MHz offset Upper 30 kHz Chan Power Ch. 358, 399 .....	85
Figure 37 : Two Carriers - B Band IS95 Spurious emissions 10kHz-400 MHz .....	86
Figure 38 : Two Carriers - B Band IS95 Spurious emissions 400 MHz to Lower 1 MHz Band Edge	87
Figure 39 : Two Carriers - B Band IS95 Spurious emissions Upper 1 MHz Band Edge to 1 GHz .	88
Figure 40 : Two Carriers - B Band IS95 Spurious emissions 400-1000 MHz .....	89
Figure 41 : Two Carriers - B Band IS95 Spurious emissions 1000-2000 MHz .....	90
Figure 42 : Two Carriers - B Band IS95 Spurious emissions 2000-3000 MHz .....	91
Figure 43 : Two Carriers - B Band IS95 Spurious emissions 3000-4000 MHz .....	92
Figure 44 : Two Carriers - B Band IS95 Spurious emissions 4000-5000 MHz .....	93
Figure 45 : Two Carriers - B Band IS95 Spurious emissions 5000-6000 MHz .....	94
Figure 46 : Two Carriers - B Band IS95 Spurious emissions 6000-7000 MHz .....	95
Figure 47 : Two Carriers - B Band IS95 Spurious emissions 7000-8000 MHz .....	96
Figure 48 : Two Carriers - B Band IS95 Spurious emissions 8000-9000 MHz .....	97
Figure 49 : Two Carriers - B Band IS95 Spurious emissions 9000-10000 MHz .....	98
Figure 50 : Three Carriers - Occupied Bandwidth Ch 1015, 33, 74 A'' .....	99

Figure 51 : Three Carriers - A'' Band Ch 1015, 33, 74 IS95 Adjacent 1MHz Lower emissions 868-869MHz ..... 100

Figure 52 : Three Carriers - Ch 1015, 33, 74 IS95 Lower A'' Band Adjacent to outside edge 37.5kHz band Channel Power ..... 101

Figure 53 : Three Carriers - Ch 226, 267, 308 Upper a Band adjacent 1 MHz band emissions 880-881 MHz ..... 102

Figure 54 : Three Carriers - Ch 226, 267, 308 Upper A Band adjacent to outside edge 37.5 kHz band Channel power ..... 103

Figure 55 : Three Carriers - Industry Canada Lower 750 kHz offset 30 kHz Chan Power Ch 1015, 33, 74 ..... 104

Figure 56 : Three Carriers - Industry Canada Upper 750 kHz offset 30 kHz Chan Power Ch 1015, 33, 74 ..... 105

Figure 57 : Three Carriers - Industry Canada 1.98 MHz offset Lower 30 kHz Chan Power Ch 1015, 33, 74 ..... 106

Figure 58 : Three Carriers - Industry Canada 1.98 MHz offset Upper 30 kHz Chan Power Ch 1015, 33, 74 ..... 107

Figure 59 : Three Carriers - A'' and A Band IS95 Spurious emissions 10kHz-400 MHz ..... 108

Figure 60 : Three Carriers - A'' and A Band IS95 Spurious emissions 400 MHz to Lower 1 MHz Band Edge ..... 109

Figure 61 : Three Carriers - A'' and a Band IS95 Spurious emissions Upper 1 MHz Band Edge to 1 GHz ..... 110

Figure 62 : Three Carriers - A'' and A Band IS95 Spurious emissions 400-1000 MHz ..... 111

Figure 63 : Three Carriers - A'' and A Band IS95 Spurious emissions 1000-2000 MHz ..... 112

Figure 64 : Three Carriers - A'' and A Band IS95 Spurious emissions 2000-3000 MHz ..... 113

Figure 65 : Three Carriers - A'' and A Band IS95 Spurious emissions 3000-4000 MHz ..... 114

Figure 66 : Three Carriers - A'' and A Band IS95 Spurious emissions 4000-5000 MHz ..... 115

Figure 67 : Three Carriers - A'' and A Band IS95 Spurious emissions 5000-6000 MHz ..... 116

Figure 68 : Three Carriers - A'' and A Band IS95 Spurious emissions 6000-7000 MHz ..... 117

Figure 69 : Three Carriers - A'' and A Band IS95 Spurious emissions 7000-8000 MHz ..... 118

Figure 70 : Three Carriers - A'' and A Band IS95 Spurious emissions 8000-9000 MHz ..... 119

Figure 71 : Three Carriers - A'' and A Band IS95 Spurious emissions 9000-10000 MHz ..... 120

Figure 72 : 1 Carrier - Occupied Bandwidth Channel 358 ..... 121

Figure 73 : One Carrier - B Band Ch 358 IS856 Adjacent 1 MHz Lower emissions 879-880 MHz 122

Figure 74 : One Carrier - Ch3585 IS856 Lower B Band Adjacent to outside edge 12.5kHz band Channel Power ..... 123



Figure 75 : One Carrier - Ch 642 Upper A Band adjacent 1MHz band emissions.....	124
Figure 76 : One Carrier - Ch 642 Upper B Band adjacent to outside edge 12.5 kHz band Channel power .....	125
Figure 77 : One Carrier - Industry Canada Lower 750 kHz offset 30 kHz Chan Power Ch 358 .....	126
Figure 78 : One Carrier - Industry Canada Upper 750 kHz offset 30 kHz Chan Power Ch 358	127
Figure 79 : One Carrier - Industry Canada 1.98 MHz offset Lower 30 kHz Chan Power Ch 358...	128
Figure 80 : One Carrier - Industry Canada 1.98 MHz offset Upper 30 kHz Chan Power Ch 358...	129
Figure 81 : One Carrier - B Band IS856 Spurious emissions 10kHz-400 MHz.....	130
Figure 82 : One Carrier - B Band IS856 Spurious emissions 400 MHz to Lower 1 MHz Band Edge	131
Figure 83 : One Carrier - B Band IS856 Spurious emissions Upper 1 MHz Band Edge to 1 GHz .	132
Figure 84 : One Carrier - B Band IS856 Spurious emissions 400-1000 MHz .....	133
Figure 85 : One Carrier -B Band IS856 Spurious emissions 1000-2000 MHz .....	134
Figure 86 : One Carrier - B Band IS856 Spurious emissions 2000-3000 MHz .....	135
Figure 87 : One Carrier - B Band IS856 Spurious emissions 3000-4000 MHz .....	136
Figure 88 : One Carrier - B Band IS856 Spurious emissions 4000-5000 MHz .....	137
Figure 89 : One Carrier - B Band IS856 Spurious emissions 5000-6000 MHz .....	138
Figure 90 : One Carrier - B Band IS856 Spurious emissions 6000-7000 MHz .....	139
Figure 91 : One Carrier - B Band IS856 Spurious emissions 7000-8000 MHz .....	140
Figure 92 : One Carrier - B Band IS856 Spurious emissions 8000-9000 MHz .....	141
Figure 93 : One Carrier - B Band IS856 Spurious emissions 9000-10000 MHz .....	142
Figure 94 : Three Carriers - Occupied Bandwidth Ch 358, 399, 440.....	143
Figure 95 : Three Carriers - B Band Ch 358, 399, 440 IS856 Adjacent 1MHz Lower emissions 879-880MHz.....	144
Figure 96 : Three Carriers - Ch 358, 399, 440 IS856 Lower B Band Adjacent to outside edge 37.5kHz band Channel Power .....	145
Figure 97 : Three Carriers - Ch 560, 601, 642 Upper a Band adjacent 1 MHz band emissions 890-891 MHz.....	146
Figure 98 : Three Carriers - Ch 560, 601, 642 Upper B Band adjacent to outside edge 37.5 kHz band Channel power .....	147
Figure 99 : Three Carriers - Industry Canada Lower 750 kHz offset 30 kHz Chan Power Ch 358, 399, 440 .....	148

---

Figure 100 : Three Carriers - Industry Canada Upper 750 kHz offset 30 kHz Chan Power Ch 358, 399, 440 .....	149
Figure 101 : Three Carriers - Industry Canada 1.98 MHz offset Lower 30 kHz Chan Power Ch 358, 399, 440 .....	150
Figure 102 : Three Carriers - Industry Canada 1.98 MHz offset Upper 30 kHz Chan Power Ch 358, 399, 440 .....	151
Figure 103 : Three Carriers - B Band IS856 Spurious emissions 10kHz-400 MHz .....	152
Figure 104 : Three Carriers - B Band IS856 Spurious emissions 400 MHz to Lower 1 MHz Band Edge .....	153
Figure 105 : Three Carriers - B Band IS856 Spurious emissions Upper 1 MHz Band Edge to 1 GHz	154
Figure 106 : Three Carriers - B Band IS856 Spurious emissions 400-1000 MHz .....	155
Figure 107 : Three Carriers - B Band IS856 Spurious emissions 1000-2000 MHz .....	156
Figure 108 : Three Carriers - B Band IS856 Spurious emissions 2000-3000 MHz .....	157
Figure 109 : Three Carriers - B Band IS856 Spurious emissions 3000-4000 MHz .....	158
Figure 110 : Three Carriers - B Band IS856 Spurious emissions 4000-5000 MHz .....	159
Figure 111 : Three Carriers - B Band IS856 Spurious emissions 5000-6000 MHz .....	160
Figure 112 : Three Carriers - B Band IS856 Spurious emissions 6000-7000 MHz .....	161
Figure 113 : Three Carriers - B Band IS856 Spurious emissions 7000-8000 MHz .....	162
Figure 114 : Three Carriers - B Band IS856 Spurious emissions 8000-9000 MHz .....	163
Figure 115 : Three Carriers - B Band IS856 Spurious emissions 9000-10000 MHz .....	164
Figure 116 : Combined Three Carriers - Occupied Bandwidth Ch 358, 399, 440 .....	166
Figure 117 : Combined Three Carriers - B Band Ch 358, 399 (IS856), 440 IS95 Adjacent 1MHz Lower emissions 879-880MHz.....	167
Figure 118 : Combined Three Carriers - Ch 358, 399 (IS856), 440 (IS95) Lower B Band Adjacent to outside edge 37.5kHz band Channel Power .....	168
Figure 119 : Combined Three Carriers - Ch 560, 601, 642 Upper a Band adjacent 1 MHz band emissions 890-891 MHz .....	169
Figure 120 : Three Carriers - Ch 560, 601, 642 Upper B Band adjacent to outside edge 37.5 kHz band Channel power .....	170
Figure 121 : Combined Three Carriers - Industry Canada Lower 750 kHz offset 30 kHz Chan Power Ch 358, 399 (IS856), 440 (IS95).....	171
Figure 122 : Combined Three Carriers - Industry Canada Upper 750 kHz offset 30 kHz Chan Power Ch 358, 399 (IS856), 440 (IS95).....	172
Figure 123 : Combined Three Carriers - Industry Canada 1.98 MHz offset Lower 30 kHz Chan Power Ch 358, 399 (IS856), 440 (IS95).....	173

---

Figure 124 : Combined Three Carriers - Industry Canada 1.98 MHz offset Upper 30 kHz Chan Power Ch 358, 399 (IS856), 440 (IS95).....	174
Figure 125 : Combined Three Carriers - B Band IS856 Spurious emissions 10kHz-400 MHz.....	175
Figure 126 : Combined Three Carriers - B Band IS856 Spurious emissions 400 MHz to Lower 1 MHz Band Edge.....	176
Figure 127 : Combined Three Carriers - B Band IS856 Spurious emissions Upper 1 MHz Band Edge to 1 GHz.....	177
Figure 128 : Combined Three Carriers - B Band IS856 Spurious emissions 400-1000 MHz ...	178
Figure 129 : Combined Three Carriers - B Band 2-IS856/1-IS95 Spurious emissions 1000-2000 MHz .....	179
Figure 130 : Combined Three Carriers - B Band 2-IS856/1-IS95 Spurious emissions 2000-3000 MHz .....	180
Figure 131 : Combined Three Carriers - B Band 2-IS856/1-IS95 Spurious emissions 3000-4000 MHz .....	181
Figure 132 : Combined Three Carriers - B Band 2-IS856/1-IS95 Spurious emissions 4000-5000 MHz .....	182
Figure 133 : Combined Three Carriers - B Band 2-IS856/1-IS95 Spurious emissions 5000-6000 MHz .....	183
Figure 134 : Combined Three Carriers - B Band 2-IS856/1-IS95 Spurious emissions 6000-7000 MHz .....	184
Figure 135 : Combined Three Carriers - B Band 2-IS856/1-IS95 Spurious emissions 7000-8000 MHz .....	185
Figure 136 : Combined Three Carriers - B Band 2-IS856/1-IS95 Spurious emissions 8000-9000 MHz .....	186
Figure 137 : Combined Three Carriers - B Band 2-IS856/1-IS95 Spurious emissions 9000-10000 MHz .....	187

## List of Tables

Table 1 : Required Tests .....	17
Table 2 : EUT Identification List.....	19
Table 3 : Test Equipment List.....	20
Table 4 : Spectrum Analyzer Noise Floor .....	22
Table 5 : RF Output Power MFRM 800 MHz Radio 1-Carrier IS95 .....	23
Table 6 : RF Output Power MFRM 800 MHz Radio 2-Carrier IS95 .....	23
Table 7 : RF Output Power of MFRM 800 MHz Radio 3-Carrier IS95.....	23
Table 8 : RF Output Power MFRM 800 MHz Radio 1-Carrier IS856 16QAM.....	24
Table 9 : RF Output Power of MFRM 800 MHz Radio 3-Carrier IS856 16QAM .....	24
Table 10 : RF Output Power of MFRM 800 MHz Radio 3-Carrier 2-IS856 16QAM, 1-IS95 ....	24
Table 11 : Measured Occupied Bandwidth MFRM 800 MHz Radio 1-Carrier IS95.....	26
Table 12 : Measured Occupied Bandwidth MFRM 800 MHz Radio 2-Carrier IS95.....	27
Table 13 : Measured Occupied Bandwidth of MFRM 800 MHz Radio 3-Carrier IS95 .....	27
Table 14 : Measured Occupied Bandwidth of MFRM 800 MHz Radio 1-Carrier IS856 16QAM..	27
Table 15 : Measured Occupied Bandwidth of MFRM Tadio 3-Carrier IS856 16QAM .....	27
Table 16 : Measured Occupied Bandwidth of MFRM 800 MHz Radio 3-Carrier 2-IS856 16QAM, 1-IS95.....	28
Table 17 : Adjacent 1MHZ Spectrum Analyze Settings .....	30
Table 18 : All other Emission Spectrum Analyze Settings .....	31
Table 19 : Spurious Emissions Requirements .....	31
Table 20 : Spurious Emissions at the MFRM 800 MHz Radio Ant. Port one Carrier band A and A'' IS95 .....	33
Table 21 : Spurious Emissions at the MFRM 800 MHz Radio Ant. Port Three Carrier band A and A'' IS-95.....	34
Table 22 : Spurious Emissions at the MFRM 800 MHz Radio Ant. Port One Carrier band B IS-95	35
Table 23 : Spurious Emissions at the MFRM 800 MHz Radio Ant. Port Two Carrier band B IS-95 .....	36
Table 24 : Spurious Emissions at the MFRM 800 MHz Radio Ant. Port Three Carrier band B IS-95 .....	37
Table 25 : Spurious Emissions at the MFRM 800 MHz Radio Ant. Port One Carrier band A' IS-95 .....	38

---

Table 26 : Spurious Emissions at the MFRM 800 MHz Radio Ant. Port One Carrier band B' IS95 39	
Table 27 : Spurious Emissions at the MFRM 800 MHz Radio Ant. Port One Carrier band B IS-856 .....	40
Table 28 : Spurious Emissions at the MFRM 800 MHz Radio Ant. Port Three Carrier band B IS-856 .....	41
Table 29 : Spurious Emissions at the MFRM 800 MHz Radio Ant. Port Three Carrier band B Combined IS-856 (Ch 358, 399)and IS-95 (Ch 440) .....	42
Table 30 : Adjacent 750 KHz and 1.98 MHz Spectrum Analyze Settings .....	44
Table 31 : Industry Canada Suppression inside cellular band MFRM 800 MHz Radio Antenna Port IS95, 1 Carrier band A'' .....	46
Table 32 : Industry Canada Suppression inside cellular band MFRM 800 MHz Radio Antenna Port IS95, 3 Carrier band A'' and A .....	47
Table 33 : Industry Canada Suppression inside cellular band MFRM 800 MHz Radio Antenna Port IS95, 1 Carrier band B' .....	48
Table 34 : Industry Canada Suppression inside cellular band MFRM 800 MHz Radio Antenna Port IS856 16QAM, 1 Carrier band B .....	49
Table 35 : Industry Canada Suppression inside cellular band MFRM 800 MHz Radio Antenna Port IS856 16QAM, 3 Carriers band B .....	50
Table 36 : Test results for Frequency Stability versus Power supply Voltage at 25C .....	52
Table 37 : Test results for Frequency Stability versus Temperature at -48V operation .....	53
Table 38 : Test results for Frequency Stability versus Temperature at 24V operation .....	54

## Publication History

The latest controlled release of this document is located in Livelink at the following location:

<http://livelink-ott.ca.nortel.com/livelink/livelink.exe?func=ll&objId=9703000&objAction=browse&sort=name>

All other soft and hard copies are uncontrolled. It is the responsibility of the reader to ensure that the latest release of this document is being used.

## List of Consultants

The following people have reviewed this document prior to its release and have recommended its approval:

Printed Name	Function	Department
Mark Willett	RF Hardware & System	2M60
Tuan Tran	BTS Cell Site System	2M69
Vladimir Mandrusov	BTS Cell Site System	2M69
Borislav Todorov	BTS RF System	2M64
Thomas Wong	CDMA/TDMA Regulatory Prime	2U40
James Loo	BTS RF Systems	2M64
Richard Kerslake	RF System & OEM Development	2M67

## Decision Maker

Decision Maker's Name	Signature	Date
Thomas Wong	Thomas Wong	

## Decision Ratifier

The release of this document has been reviewed and approved for distribution and use by the following:

Ratifier's Name	Signature	Date
Tom Danshin	Tom Danshin	

---

## Revision History

<b>Stream/Issue</b>	<b>Revision Date</b>	<b>Reason for Change</b>	<b>Author</b>
00/0.1	14/04/2004	Draft release of test Report	Tuan Tran
00/0.2	13/05/2004	Update Frequency errors data	Tuan Tran
00/0.3	18/06/2004	Update plots, Frequency Error data	Tuan Tran
00/04	15/07/2004	Approval Release of Test Report	Tuan Tran

Change bars will not be used in this document.

---

## Acronyms and Abbreviations

BPF	Bandpass Filter
BTS	Base Station Transceiver Subsystem
BW	Bandwidth
CDMA	Code Division Multiple Access
CEM	Channel Enhancement Module
CM	Control Module
CR	Cost Reduced
DE	Digital Encloser
DPM	Duplexer Preselector Module
FAM	Fan and Alarm Module
GPSTM	Global Position System Timing Module
LO	Local Oscillator
MFRM	Multi-Carrier Flexible Radio Module
MPAM	Multi-Carrier Power Amplifier Module
MTRM	Multi-Carrier Transmitter and Receiver Module
PA	Power Amplifier
RBW	Resolution BandWidth
RM	Radio Module
RMS	Root Mean Square
RF	Radio Frequency
SA	Spectrum Analyzer
TBD	To Be Determined





# 1 Introduction

This test report supports FCC filing for the MFRM 800 MHz Radio. This test report will be used as a filing for FCC part 22. This filing includes single, two and three carrier modes for the 800MHz cellular band. The following test results include; RF Power Output, Occupied Bandwidth, Spurious Emissions at Antenna Terminals, and Transmitter Test (CDMA Mode Transmitter). Frequency over voltage and temperature test results are included. Emissions testing was conducted at -48VDC at room temperature. The IS95 and IS856 modulation schemes will be included in this report.

This test report is submitted in accordance with the FCC Rules and Regulations, Part 2, Subpart J, Sections 2.1046 through 2.1057 for equipment authorization of Nortel Networks' MFRM 800 MHz Radio.

The MFRM 800 MHz Radio is intended for use in the Domestic Public Cellular Radio Telecommunications Service and is designed in accordance with the following standards:

- *CFR 47, Part 22, Subpart H, Cellular Radiotelephone Service [1]*
- *CFR 47, Part 2, Subpart J, Equipment Authorization Procedures - Equipment Authorization[2]*
- *IC RSS-129, Issue 2, 800 MHz Dual-Mode CDMA Cellular Telephones [3]*
- *TIA/EIA-97-D, Recommended Minimum Performance Standards for Base Stations Supporting Dual Mode Spread Spectrum Systems [4]*

## 1.1 Required Tests

Table 1 summarizes the required tests for the MFRM 800 MHz Radio.

**Table 1 : Required Tests**

<b>FCC Measurement Specification</b>	<b>FCC Limit Specification</b>	<b>Description</b>	<b>Test to be Performed?</b>
2.1046	22.913	RF Power Output	Yes
2.1049	22.917	Occupied Bandwidth	Yes
2.1051, 2.1057	22.917	Spurious Emissions at Antenna Terminals	Yes
2.1053, 2.1057	22.917	Field Strength of Spurious Emissions	Yes <sup>a</sup>
2.1055	22.355	Frequency Stability	Yes

a. Field strength of spurious emissions testing will be performed by Sanmina-SCI Canada, Calgary.

## 2 Engineering Declaration

The CDMA MFRM 800 MHz Radio has been tested in accordance with the requirements contained in the Federal Communications Commission Rules and Regulations Part 2 and 22.

To the best of my knowledge, these tests were performed in accordance with good engineering practices using measurement procedures consistent with industry or commission standards or previous Commission correspondence or guidance and demonstrate that this equipment complies with the appropriate standards. All tests were conducted on a representative sample of the equipment for which equipment authorization is sought.

Tested by:  
Tuan Tran  
Systems Test Prime  
Nortel Networks  
Calgary Canada

  
Signature

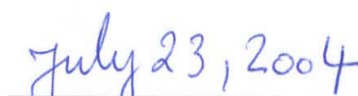
  
Date

Reviewed by:  
Thomas Wong  
CDMA/TDMA Regulatory  
Emissions Prime  
Nortel Networks  
Calgary Canada

  
Signature

  
Date

Approved by:  
Tom Danshin  
BTS System Manager  
Nortel Networks  
Calgary Canada

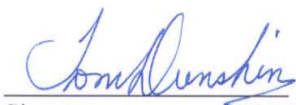
  
Signature

  
Date

### 3 Equipment Authorization Application Requirements

#### 3.1 Standard Test Conditions and Test Equipment

The MFRM 800 MHz Radio will be tested under the following standard test conditions unless otherwise noted:

- Ambient Temperature: 20 to 35 degrees C
- Ambient Humidity: 20 to 40%
- DC Supply Voltage: -48 Vdc and +24 Vdc (nominal)
- Input modulation IS-95 and IS-856 (16 QAM)

#### 3.2 EUT Identification List

Table 2 shows the identification of the components required for testing.

**Table 2 : EUT Identification List**

<b>Equipment Description</b>	<b>Model / Part Number</b>	<b>Release Number</b>	<b>Serial Number</b>
MTRM803 +24V	NPGY10DA	P4	NNTM535XDDFF
MPAM +24V	NPGY70AA	R1	NNTM534XMVPX
MTRM803 -48V	NTGY10CA	MP	NNTM538FG3L1
MPAM -48V	NTGY70AB	69	NNTM532RXP84
800 DPM - Diplexer	NTGS89DB	15	ALLG74000C02
800 FAM - Fan	NTGS60AD	01	NNTM5389TVJ2
DC Power Cable	NTGS8082	N/A	N/A
Fiber Cable	NTGY5520	N/A	N/A
DPM Power/Data Cable	NTGS5503	N/A	N/A
DPM to RX0 Cable	NTGS8069	N/A	N/A
DPM to RX1 Cable	NTGS8069	N/A	N/A

### 3.3 Test Equipment List

Table 3 shows the identification of the test equipment required.

**Table 3 : Test Equipment List**

<b>Description</b>	<b>Manufacturer</b>	<b>Model</b>	<b>Serial Number</b>	<b>Cal. Due Date</b>
9kHz to 40 GHz Spectrum Analyzer	Rohde&Schwarz	FSEK-30	DE25178	19 MAY 2005
VSA Series Transmitter Tester	Agilent	E4406A	US40061527	12 NOV 2004
RF Power Meter	Agilent	E4419B	US38260822	6 DEC 2005
RF Power Sensor Head	Agilent	E9300A	US39210633	09 DEC 2004
30dB Attenuator (>100W)	Weinschel	40-30-43	KL694	n/a
RF Cable 1 24"	Nortel	A0734233	n/a	n/a
RF Cable 2 8m Heliac	Nortel	A0803065	n/a	n/a

## 4 Transmitter Tests

### 4.1 RF Power Output

#### 4.1.1 RF Power Output Requirements

##### **FCC Part 2.1046 Measurements required: RF power output**

*§(a) For transmitters other than single sideband, independent sideband and controlled carrier radiotelephone, power output shall be measured at the RF output terminals when the transmitter is adjusted in accordance with the tune-up procedure to give the values of current and voltage on the circuit elements specified in §2.1033(c)(8). The electrical characteristics of the radio frequency load attached to the output terminals when this test is made shall be stated.*

*(c) For measurements conducted pursuant to paragraphs (a) and (b) of this section, all calculations and methods used by the applicant for determining carrier power or peak envelope power, as appropriate, on the basis of measured power in the radio frequency load attached to the transmitter output terminals shall be shown. Under the test conditions specified, no components of the emission spectrum shall exceed the limits specified in the applicable rule parts as necessary for meeting occupied bandwidth or emission limitations.*

#### 4.1.2 Test Method

Setup the DE via the BTS controller to enable the MFRM 800 MHz Radio to transmit at the rated power for each of the carrier configurations one, two and three carrier in the Baseband modulation formats IS-95 and IS-856 (16 QAM). Measurements will be made on channels at the bottom and top of the operator bands with the Radio operating with -48Vdc. The RF output power will be measured using the power meter.

#### 4.1.3 Test Setup

The set-up required for the MFRM 800 MHz Radio RF output power test is illustrated in Figure 1. RF output power measurements will be referenced to the antenna port of the DPM

#### 4.1.4 IS-95

The conducted spurious emissions of the MFRM 800 MHz Radio, with IS-95 waveforms were tested at maximum power. Transmitters operating with IS95 are tested at +47.3 dBm.

#### 4.1.5 DOM

The conducted spurious emissions of the MFRM 800 MHz Radio, with IS-856 (1xEV DO) waveforms were tested at maximum power. Transmitters operating with IS856 are tested at +47.3 dBm.

### 4.1.6 Noise Floor

Table 4 lists the noise floor of the measurement system with no signal present.

**Table 4 : Spectrum Analyzer Noise Floor**

Start (MHz)	Stop (MHz)	Peak (dBm)	RBW kHz
0.01	400	-42.19	100
400	1000	-39.73	100
1000	2000	-37.82	100
2000	3000	-37.04	100
3000	4000	-36.06	100
4000	5000	-36.13	100
5000	6000	-33.52	100
6000	7000	-29.81	100
7000	8000	-31.88	100
8000	9000	-32.18	100
9000	10000	-32.77	100

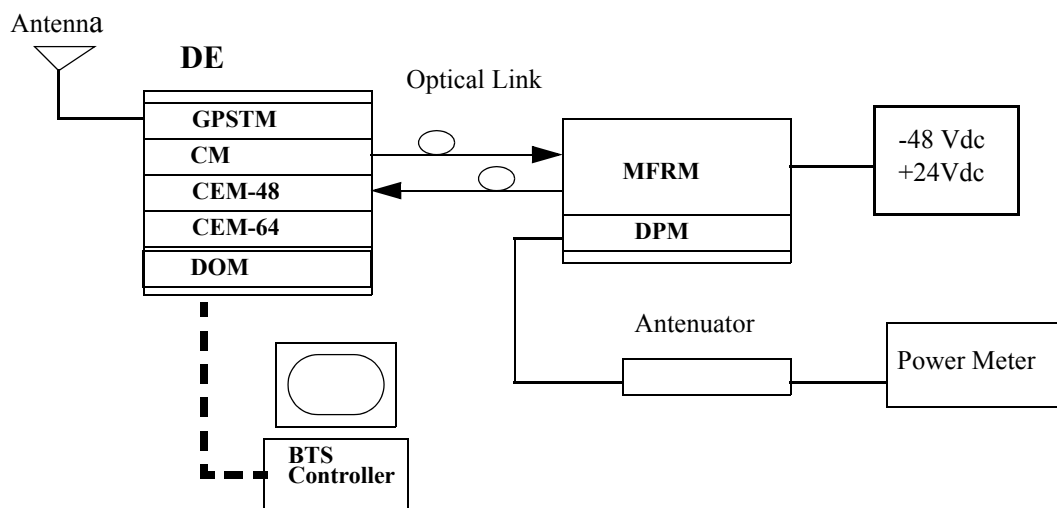

**Figure 1 : Test Setup for RF Power Output Measurement**

### 4.1.7 RF Output Power Test Results

**Table 5 : RF Output Power MFRM 800 MHz Radio 1-Carrier IS95**

Channel Number (Band)	Frequency (MHz)	Measured RF Output Power (dBm)	Typical Maximum Rated Power (dBm)
1015 (A')	869.76	47.27	47.3
308 (A)	879.24	47.18	47.3
358 (B)	880.74	47.3	47.3
642 (B)	889.26	47.31	47.3
692 (A')	890.76	47.32	47.3
742 (B')	892.26	47.22	47.3
775 (B')	893.25	47.26	47.3

**Table 6 : RF Output Power MFRM 800 MHz Radio 2-Carrier IS95**

Channel Number (Band)	Frequency (MHz)	Measured RF Output Power (dBm)	Typical Maximum Rated Power (dBm)
358, 399 (B)	880.74, 881.97,	47.26	47.3
601, 642 (B)	886.8, 888.03	47.32	47.3

**Table 7 : RF Output Power of MFRM 800 MHz Radio 3-Carrier IS95**

Channel Number (Band)	Frequencies (MHz)	Measured RF Output Power (dBm)	Typical Maximum Rated Power (dBm)
1015, 33, 74 (A''&A)	869.76, 870.99, 872.22	47.25	47.3
226, 267, 308 (A)	876.78, 878.01, 879.24	47.36	47.3
358, 399, 440 (B)	880.74, 881.97, 883.20	47.34	47.3
560, 601, 642 (B)	886.8, 888.03, 889.26	47.19	47.3



**Table 8 : RF Output Power MFRM 800 MHz Radio 1-Carrier IS856 16QAM**

Channel Number (Band)	Frequencies (MHz)	Measured RF Output Power (dBm)	Typical Maximum Rated Power (dBm)
358 (B)	880.74	47.36	47.3
642 (B)	889.26	47.4	47.3

**Table 9 : RF Output Power of MFRM 800 MHz Radio 3-Carrier IS856 16QAM**

Channel Number (Band)	Frequencies (MHz)	Measured RF Output Power (dBm)	Typical Maximum Rated Power (dBm)
358, 399, 440 (B)	880.74, 881.97, 883.20	47.39	47.3
560, 601, 642 (B)	886.8, 888.03, 889.26	47.4	47.3

**Table 10 : RF Output Power of MFRM 800 MHz Radio 3-Carrier 2-IS856 16QAM, 1-IS95**

Channel Number (Band)	Frequencies (MHz)	Measured RF Output Power (dBm)	Typical Maximum Rated Power (dBm)
358, 399, 440 (B)	880.74, 881.97, 883.20	47.29	47.3
560, 601, 642 (B)	886.8, 888.03, 889.26	47.32	47.3

## 4.2 Occupied Bandwidth

### 4.2.1 Occupied Bandwidth Requirements

#### FCC Part 2.1049

*The OBW, that is the frequency bandwidth such that, below its lower and above its upper frequency limits, the mean powers radiated are each equal to 0.5 percent of the total mean power radiated by a given emission shall be measured under the following conditions as applicable:*

*(g) Transmitter in which the modulating baseband comprises not more than three independent channels - when modulated by the full complement of signals for which the transmitter is rated. The level of modulation for each channel should be set to that prescribed in rule parts applicable to the services for which the transmitter is intended. If specific modulation levels are not set forth in the rules, the tests should provide the manufacturer's maximum rated condition.*

*(h) Transmitters employing digital modulation techniques - when modulated by an input signal such that its amplitude and symbol rate represent the maximum rated conditions under which the equipment will be operated. The signal shall be applied through any filter networks, pseudo-random generators or other devices required in normal service. Additionally, the occupied bandwidth shall be shown for operation with any devices used for modifying the spectrum when such devices are optional at discretion of the user.*

### 4.2.2 Test Method

Setup the DE via the BTS controller to enable the MFRM 800 MHz to transmit at maximum rated power for each of the carrier configurations one, two and three carrier in the Baseband modulation formats IS-95 and IS-856. Measurements will be made on channels at the bottom and top of each of the operator bands.

A reference level is established by first using a resolution bandwidth that exceeds the signal bandwidth. RBW is then set to 1% of the estimated emission bandwidth and the video bandwidth is set to 3 times the resolution bandwidth. The markers are now moved to the -20 dB points (from the previously established reference level) on either side of centre frequency.

### 4.2.3 Test Setup

The set-up required for the MFRM 800 MHz Radio Occupied bandwidth test is illustrated in Figure 2.

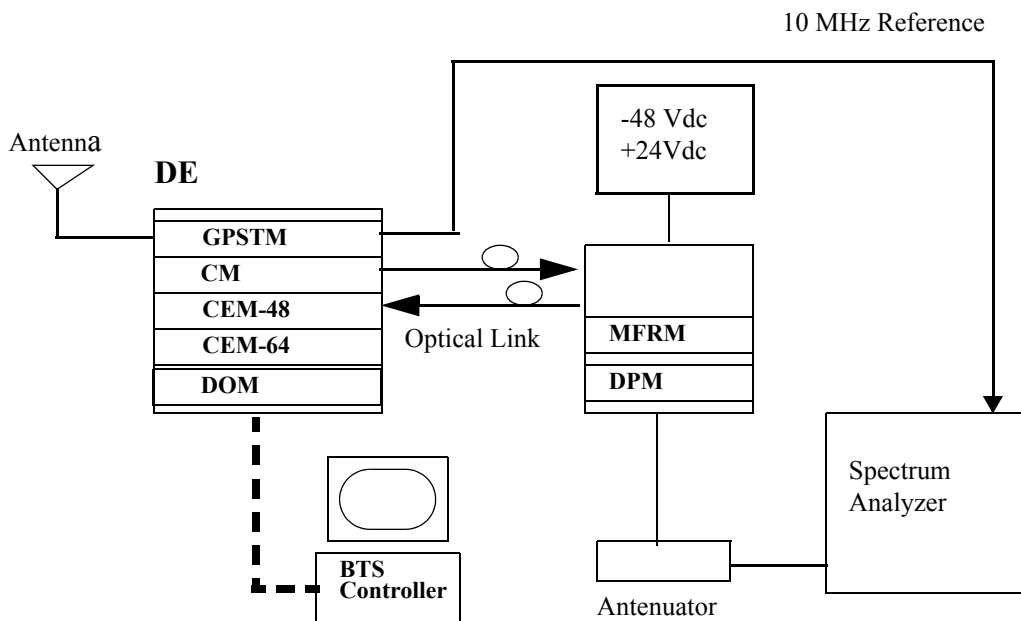

**Figure 2 : Test Setup for Occupied Bandwidth Measurement**

**4.2.4 Test Result**

**Table 11 : Measured Occupied Bandwidth MFRM 800 MHz Radio 1-Carrier IS95**

Channel Number (Band)	Frequency (MHz)	Measured Occupied Bandwidth (MHz) (1-Carrier)
1015 (A')	869.76	1.2585
308 (A)	879.24	1.2585
358 (B)	880.74	1.2585
642 (B)	889.26	1.2545
692 (A')	890.76	1.2545
742 (B')	892.26	1.2585
775 (B')	893.25	1.2545

**Table 12 : Measured Occupied Bandwidth MFRM 800 MHz Radio 2-Carrier IS95**

Channel Number (Band)	Frequency (MHz)	Measured Occupied Bandwidth (MHz)
358, 399(B)	880.74, 881.97,	2.4529
601, 642 (B)	888.03, 889.26	2.4609

**Table 13 : Measured Occupied Bandwidth of MFRM 800 MHz Radio 3-Carrier IS95**

Channel Number (Band)	Frequencies (MHz)	Measured Occupied Bandwidth (MHz)
1015, 33, 74 (A'', A)	869.76, 870.99, 872.22	3.671
226, 267, 308 (A)	876.78, 878.01, 879.24	3.671
358, 399, 440 (B)	880.74, 881.97, 883.20	3.671
560, 601, 642 (B)	886.8, 888.03, 889.26	3.671

**Table 14 : Measured Occupied Bandwidth of MFRM 800 MHz Radio 1-Carrier IS856 16QAM**

Channel Number (Band)	Frequencies (MHz)	Measured Occupied Bandwidth (MHz)
358 (B)	880.74	1.2545
642 (B)	889.26	1.250

**Table 15 : Measured Occupied Bandwidth of MFRM Tadio 3-Carrier IS856 16QAM**

Channel Number (Band)	Frequencies (MHz)	Measured Occupied Bandwidth (MHz)
358, 399, 440 (B)	880.74, 881.97, 883.20	3.671

**Table 15 : Measured Occupied Bandwidth of MFRM Tadio 3-Carrier IS856 16QAM**

Channel Number (Band)	Frequencies (MHz)	Measured Occupied Bandwidth (MHz)
560, 601, 642 (B)	886.8, 888.03, 889.26	3.671

**Table 16 : Measured Occupied Bandwidth of MFRM 800 MHz Radio 3-Carrier 2-IS856  
16QAM, 1-IS95**

Channel Number (Band)	Frequencies (MHz)	Measured Occupied Bandwidth (MHz)
358, 399, 440 (B)	880.74, 881.97, 883.20	3.671
560, 601, 642 (B)	886.8, 888.03, 889.26	3.671

## 4.3 Spurious Emissions at Antenna Terminals

### 4.3.1 Spurious Emissions Requirements

#### FCC Part 2.1051

*The radio frequency voltage or powers generated within the equipment and appearing on a spurious frequency shall be checked at the equipment output terminals when properly loaded with a suitable artificial antenna. Curves or equivalent data shall show the magnitude of each harmonic and other spurious emission that can be detected when the equipment is operated under the conditions specified in 2.1049 as appropriate. The magnitude of spurious emissions which are attenuated more than 20 dB below the permissible value need not be specified.*

#### FCC Part 2.1057 - Frequency Spectrum to be investigated

*The spectrum should be investigated from the lowest radio frequency generated in the equipment up to at least the 10th harmonic of the carrier frequency or to the highest frequency practicable in the present state of the art of measuring techniques, whichever is lower. Particular attention should be paid to harmonics and subharmonics of the carrier frequency. Radiation at the frequencies of multiplier stages should be checked. The amplitude of spurious emissions which are attenuated more than 20 dB below the permissible value need not be reported.*

#### FCC Part 22.917 Limit

*Out of band emissions. The power of any emission outside of the authorized operating frequency ranges must be attenuated below the transmitting power ( $P$ ) by a factor of at least  $43 + 10 \log(P)$  dB.*

*Measurement procedure. Compliance with these rules is based on the use of measurement instrumentation employing a resolution bandwidth of 100 kHz or greater. In the 1 MHz bands immediately outside and adjacent to the frequency block a resolution bandwidth of at least one percent of the emission bandwidth of the fundamental emission of the transmitter may be employed. A narrower resolution bandwidth is permitted in all cases to improve measurement accuracy provided the measured power is integrated over the full required measurement bandwidth (i.e. 100 kHz or 1 percent of emission bandwidth, as specified). The emission bandwidth is defined as the width of the signal between two points, one below the carrier center frequency and one above the carrier center frequency, outside of which all emissions are attenuated at least 26 dB below the transmitter power.*

*Alternative out of band emission limit. Licensees in this service may establish an alternative out of band emission limit to be used at specified band edge(s) in specified geographical areas, in lieu of that set forth in this section, pursuant to a private contractual arrangement of all affected licensees and applicants. In this event, each party to such contract shall maintain a copy of the contract in their station files and disclose it to prospective assignees or transferees and, upon request, to the FCC.*

*Interference caused by out of band emissions. If any emission from a transmitter operating in this service results in interference to users of another radio service, the FCC may require a greater attenuation of that emission than specified in this section*

### 4.3.2 Test Method

Configure the BTS via the BTS controller to enable the MFRM 800 MHz to transmit at maximum rated power for each of the carrier configurations one, two and three carrier in the Baseband modulation formats IS-95 and IS-856. Measurements will be made on channels at the bottom and top of the operator bands. The following spectrum analyzer settings are to be used for the measurement of the antenna port (DPM) spurious emissions:

#### 4.3.2.1 Adjacent 1MHz to indicated cellular band (Upper and Lower)

**Table 17 : Adjacent 1MHz Spectrum Analyze Settings**

Setting	1 Carrier	2 Carrier	3 Carrier
Resolution Bandwidth <sup>a</sup> :	12.5 kHz	25 kHz	37.5 kHz
Video Bandwidth (3x RBW) <sup>b</sup>	(3x RBW)	(3x RBW)	(3x RBW)
Video Average	10 Averages	10 Averages	10 Averages
Span	Set accordingly	Set accordingly	Set accordingly
Detector	RMS	RMS	RMS
Attenuation <sup>c</sup>	30 dB	30 dB	30 dB
Ref. Level	35 dBm	35 dBm	35 dBm
Ref. Level Offset	31-34.5 dB	31-34.5 dB	31-34.5 dB

- If the spectrum analyzer cannot be set to the specified RBW the next highest RBW should be used and all measurements corrected to the specified RBW
- If the spectrum analyzer cannot be set to the specified Video Bandwidth the next highest Video Bandwidth should be used.
- The lowest value of attenuator should be used to improve measurement accuracy, without overdriving the Spectrum Analyzer.

All spectrum analyzer settings were coupled as per the manufacturers recommendations to improve measurement time, without compromising data.

**4.3.2.2 All other Spurious Emissions up to 10 GHz**

**Table 18 : All other Emission Spectrum Analyze Settings**

Setting	1 Carrier	2 Carrier	3 Carrier
Resolution Bandwidth	100 kHz	100 kHz	100 kHz
Video Bandwidth (3x RBW)	300 kHz	300 kHz	300 kHz
Video Average	10 Averages	10 Averages	10 Averages
Span	Set accordingly	Set accordingly	Set accordingly
Detector	RMS	RMS	RMS
Attenuation <sup>a</sup>	30 dB	30 dB	30 dB
Ref. Level	35 dBm	35 dBm	35 dBm
Ref. Level Offset	31-34.5 dB	31-34.5 dB	31-34.5 dB

a. The lowest value of attenuator should be used to improve measurement accuracy, without overdriving the Spectrum Analyzer.

The emissions will be investigated up to 10 GHz (the 10<sup>th</sup> harmonic of the fundamental emission) for all carrier configurations (1, 2, 3) as per FCC Part 22.

**4.3.3 Test Requirements**

**Table 19 : Spurious Emissions Requirements**

Frequency Offset	1 Carrier	2 Carrier	3 Carrier
+/- 740 kHz	< -13 dBm/12.5KHz	< -13 dBm/25 KHz	< -13 dBm/37.5 KHz



### 4.3.4 Test Setup

The set-up required for the MFRM 800 MHz Radio Antenna Port (DPM) Spurious Emission test is illustrated in Figure 3.

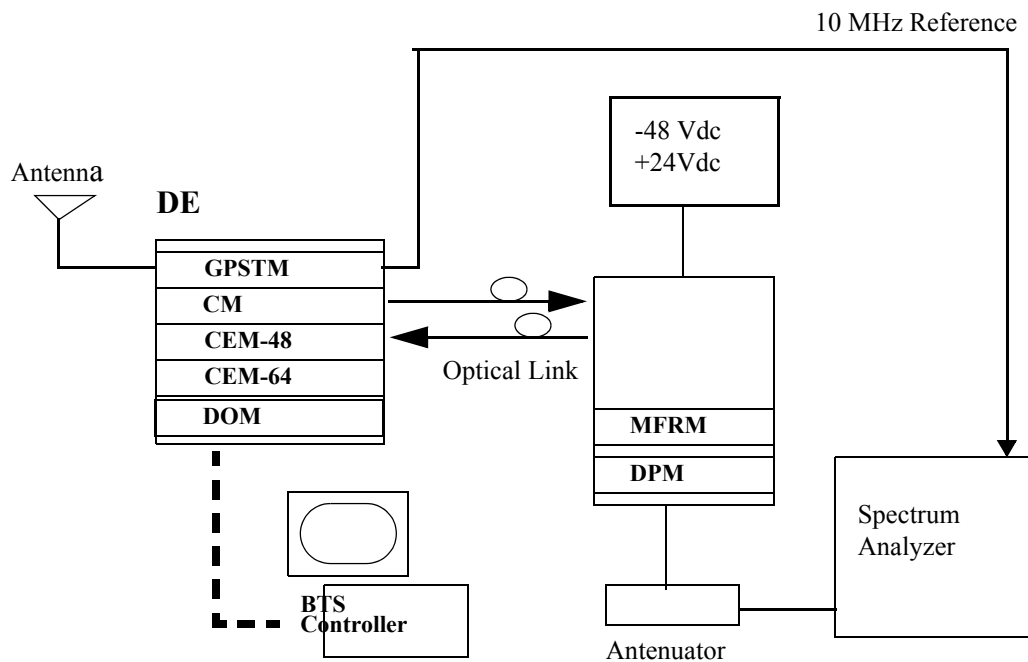

**Figure 3 : Test Setup for Spurious Emissions Measurement**

### 4.3.5 Test Results

**Table 20 : Spurious Emissions at the MFRM 800 MHz Radio Ant. Port one Carrier band A and A'' IS95<sup>a</sup>**

Frequency (MHz)	Spurious Emissions Level (dBm)	Margin to FCC Limit of -13 dBm (dB)
	1Carrier IS-95	1Carrier
869 MHz (Lower edge of band A'') Ch 1015 (RBW=12.5 kHz)	-26.79	13.79
880 MHz (Upper edge of band A) Ch 308 (RBW=12.5 kHz)	-26.91	13.91
0-1000 (RBW=100KHz)	-22.35	9.35
1000-2000 (RBW=100KHz)	-29.96	16.96
2000-3000 (RBW=100KHz)	-37.48	24.48
3000-4000 (RBW=100KHz)	-36.35	23.35
4000-5000 (RBW=100KHz)	-36.48	23.48
5000-6000 (RBW=100KHz)	-33.87	20.87
6000-7000 (RBW=100KHz)	-30.09	17.09
7000-8000 (RBW=100KHz)	-32.41	19.41
8000-9000 (RBW=100KHz)	-32.7	19.7
9000-10000 (RBW=100KHz)	-33.12	20.12

a. See Appendix A - Single Carrier IS-95 Spurious Emission

**Table 21 : Spurious Emissions at the MFRM 800 MHz Radio Ant. Port Three Carrier band A and A'' IS-95\***

Frequency (MHz)	Spurious Emissions Level (dBm)	Margin to FCC Limit of -13 dBm (dB)
	3Carrier IS-95	3Carrier
869 MHz (Lower edge of band A'') Ch 1015, 33, 74 (RBW=37.5 kHz)	-28.75	15.75
880 MHz (Upper edge of band A) Ch 226, 267, 308 (RBW=37.5 kHz)	-26.96	13.96
0-1000 (RBW=100KHz)	-27.66	14.66
1000-2000 (RBW=100KHz)	-33.73	20.73
2000-3000 (RBW=100KHz)	-38.16	25.16
3000-4000 (RBW=100KHz)	-37.43	24.43
4000-5000 (RBW=100KHz)	-37.32	24.32
5000-6000 (RBW=100KHz)	-34.74	21.74
6000-7000 (RBW=100KHz)	-31	18
7000-8000 (RBW=100KHz)	-32.96	19.96
8000-9000 (RBW=100KHz)	-33.2	20.2
9000-10000 (RBW=100KHz)	-33.75	20.75

\*. See Appendix C - Three Carriers IS-95 Spurious Emission

**Table 22 : Spurious Emissions at the MFRM 800 MHz Radio Ant. Port One Carrier band B IS-95**

Frequency (MHz)	Spurious Emissions Level (dBm)	Margin to FCC Limit of -13 dBm (dB)
	1Carrier IS-95	1Carrier
880 MHz (Lower edge of band B) Ch 358 (RBW=12.5kHz)	-23.85	10.85
890 MHz (Upper edge of band B) Ch 642 (RBW=12.5kHz)	-23.52	10.52
0-1000 (RBW=100KHz)	-21.54	8.54
1000-2000 (RBW=100KHz)	-30.53	17.53
2000-3000 (RBW=100KHz)	-37.19	24.19
3000-4000 (RBW=100KHz)	-36.5	23.5
4000-5000 (RBW=100KHz)	-36.39	23.39
5000-6000 (RBW=100KHz)	-34.09	21.09
6000-7000 (RBW=100KHz)	-30.45	17.45
7000-8000 (RBW=100KHz)	-32.61	19.61
8000-9000 (RBW=100KHz)	-32.38	19.38
9000-10000 (RBW=100KHz)	-33.03	20.03

**Table 23 : Spurious Emissions at the MFRM 800 MHz Radio Ant. Port Two Carrier band  
 B IS-95 \***

Frequency (MHz)	Spurious Emissions Level (dBm)	Margin to FCC Limit of -13 dBm (dB)
	2Carrier IS-95	2Carrier
880 MHz (Lower edge of band B) Ch 358, 399 (RBW=25 kHz)	-24.02	11.02
890 MHz (Upper edge of band B) Ch 601, 642 (RBW=25 kHz)	-24.65	11.65
0-1000 (RBW=100KHz)	-20.58	7.58
1000-2000 (RBW=100KHz)	-32.18	19.18
2000-3000 (RBW=100KHz)	-37.53	24.53
3000-4000 (RBW=100KHz)	-36.7	23.7
4000-5000 (RBW=100KHz)	-36.8	23.8
5000-6000 (RBW=100KHz)	-34.23	21.23
6000-7000 (RBW=100KHz)	-30.21	17.21
7000-8000 (RBW=100KHz)	-32.57	19.57
8000-9000 (RBW=100KHz)	-32.74	19.74
9000-10000 (RBW=100KHz)	-33.47	20.47

\*. See Appendix B - Two Carrier IS-95 Spurious Emission

**Table 24 : Spurious Emissions at the MFRM 800 MHz Radio Ant. Port Three Carrier band B IS-95**

Frequency (MHz)	Spurious Emissions Level (dBm)	Margin to FCC Limit of -13 dBm (dB)
	3Carrier IS-95	3Carrier
880 MHz (Lower edge of band B) Ch 358, 399, 440 (RBW=37.5 kHz)	-26.53	13.53
890 MHz (Upper edge of band B) Ch 560, 601, 642 (RBW=37.5 kHz)	-25.83	12.83
0-1000 (RBW=100KHz)	-27.46	14.46
1000-2000 (RBW=100KHz)	-34.47	21.47
2000-3000 (RBW=100KHz)	-37.83	24.83
3000-4000 (RBW=100KHz)	-37.18	24.18
4000-5000 (RBW=100KHz)	-37.17	24.17
5000-6000 (RBW=100KHz)	-34.69	21.69
6000-7000 (RBW=100KHz)	-30.56	17.56
7000-8000 (RBW=100KHz)	-32.87	19.87
8000-9000 (RBW=100KHz)	-33.15	20.15
9000-10000 (RBW=100KHz)	-33.83	20.83

**Table 25 : Spurious Emissions at the MFRM 800 MHz Radio Ant. Port One Carrier band  
 A' IS-95**

Frequency (MHz)	Spurious Emissions Level (dBm)	Margin to FCC Limit of -13 dBm (dB)
	1 Carrier IS-95	1 Carrier
890 Mhz (Lower edge of band A') Ch 692(RBW=12.5 kHz)	-26.33	13.33
891.5 MHz (upper edge of band A') Ch 692 (RBW=12.5kHz)	-23.65	10.65
0-1000 (RBW=100KHz)	-21.89	8.89
1000-2000 (RBW=100KHz)	-31.54	18.54
2000-3000 (RBW=100KHz)	-37.11	24.11
3000-4000 (RBW=100KHz)	-36.33	23.33
4000-5000 (RBW=100KHz)	-36.58	23.58
5000-6000 (RBW=100KHz)	-34.05	21.05
6000-7000 (RBW=100KHz)	-29.85	16.85
7000-8000 (RBW=100KHz)	-32.11	19.11
8000-9000 (RBW=100KHz)	-32.47	19.47
9000-10000 (RBW=100KHz)	-33.26	20.26

**Table 26 : Spurious Emissions at the MFRM 800 MHz Radio Ant. Port One Carrier band B' IS95**

Frequency (MHz)	Spurious Emissions Level (dBm)	Margin to FCC Limit of -13 dBm (dB)
	1 Carrier IS-95	1 Carrier
891.5 MHz (lower edge of band B') Ch 742 (RBW=12.5kHz)	-26.03	13.03
894 MHz (upper edge of band B') Ch 775 (RBW=12.5kHz)	-25.3	12.3
0-1000 (RBW=100KHz)	-20.91	7.91
1000-2000 (RBW=100KHz)	-31.73	18.73
2000-3000 (RBW=100KHz)	-37.32	24.32
3000-4000 (RBW=100KHz)	-36.41	23.41
4000-5000 (RBW=100KHz)	-36.19	23.19
5000-6000 (RBW=100KHz)	-33.74	20.74
6000-7000 (RBW=100KHz)	-30.12	17.12
7000-8000 (RBW=100KHz)	-32.37	19.37
8000-9000 (RBW=100KHz)	-32.36	19.36
9000-10000 (RBW=100KHz)	-33.01	20.01



**Table 27 : Spurious Emissions at the MFRM 800 MHz Radio Ant. Port One Carrier band B  
 IS-856 <sup>a</sup>**

Frequency (MHz)	Spurious Emissions Level (dBm)	Margin to FCC Limit of -13 dBm (dB)
	1 Carrier IS-856 16QAM	3Carrier
880 MHz (Lower edge of band B) Ch 358 (RBW=12.5 kHz)	-27.17	14.17
890 MHz (Upper edge of band B) Ch 642 (RBW=12.5 kHz)	-26.49	13.49
0-1000 (RBW=100KHz)	-21.89	8.89
1000-2000 (RBW=100KHz)	-31.46	18.46
2000-3000 (RBW=100KHz)	-37.22	24.22
3000-4000 (RBW=100KHz)	-36.51	23.51
4000-5000 (RBW=100KHz)	-36.41	23.41
5000-6000 (RBW=100KHz)	-33.91	20.91
6000-7000 (RBW=100KHz)	-29.89	16.89
7000-8000 (RBW=100KHz)	-32.28	19.28
8000-9000 (RBW=100KHz)	-32.58	19.58
9000-10000 (RBW=100KHz)	-33.21	20.21

a. See Appendix D - One Carrier IS-856 Spurious Emission

**Table 28 : Spurious Emissions at the MFRM 800 MHz Radio Ant. Port Three Carrier band B IS-856 <sup>a</sup>**

Frequency (MHz)	Spurious Emissions Level (dBm)	Margin to FCC Limit of -13 dBm (dB)
	3Carrier IS-856 16QAM	3Carrier
880 MHz (Lower edge of band B) Ch 358, 399, 440 (RBW=37.5 kHz)	-27.07	14.07
890 MHz (Upper edge of band B) Ch 560, 601, 642 (RBW=37.5 kHz)	-26.62	13.62
0-1000 (RBW=100KHz)	-27.63	14.63
1000-2000 (RBW=100KHz)	-34.23	21.23
2000-3000 (RBW=100KHz)	-38.11	25.11
3000-4000 (RBW=100KHz)	-36.98	23.98
4000-5000 (RBW=100KHz)	-37.5	24.5
5000-6000 (RBW=100KHz)	-34.86	21.86
6000-7000 (RBW=100KHz)	-30.89	17.89
7000-8000 (RBW=100KHz)	-33.16	20.16
8000-9000 (RBW=100KHz)	-33.26	20.26
9000-10000 (RBW=100KHz)	-34.25	21.25

a. See Appendix E - Three Carrier IS-856 Spurious Emission

**Table 29 : Spurious Emissions at the MFRM 800 MHz Radio Ant. Port Three Carrier band B Combined IS-856 (Ch 358, 399) and IS-95 (Ch 440) <sup>a</sup>**

Frequency (MHz)	Spurious Emissions Level (dBm)	Margin to FCC Limit of -13 dBm (dB)
	2 Ch IS-856 16QAM 1 Ch IS-95	3Carrier
880 MHz (Lower edge of band B) Ch 358, 399, 440 (RBW=37.5 kHz)	-27.56	14.56
890 MHz (Upper edge of band B) Ch 560, 601, 642 (RBW=37.5 kHz)	-25.68	12.68
0-1000 (RBW=100KHz)	-28.51	15.51
1000-2000 (RBW=100KHz)	-34.53	21.53
2000-3000 (RBW=100KHz)	-37.79	24.79
3000-4000 (RBW=100KHz)	-37.22	24.22
4000-5000 (RBW=100KHz)	-37.38	24.38
5000-6000 (RBW=100KHz)	-34.89	21.89
6000-7000 (RBW=100KHz)	-30.85	17.85
7000-8000 (RBW=100KHz)	-32.85	19.85
8000-9000 (RBW=100KHz)	-33.23	20.23
9000-10000 (RBW=100KHz)	-33.87	20.87

a. See Appendix F - Combined Three Carriers - 2 IS8-56, 1 IS-95 Spurious Emission

## 4.4 Transmitter Tests (CDMA Mode)

### Unwanted Emissions

Unwanted emissions are emissions on a frequency or frequencies outside the necessary bandwidth which result from the modulation process, from spurious emissions and harmonics.

#### IC RSS-129

*(1) Suppression inside cellular band: For all base station transmit frequencies allocated to the same operator system, the total spurious emissions in any 30 kHz band shall be attenuated below the mean output power level in accordance with the following schedule:*

*(a) for all offset frequencies greater than 750 kHz from the CDMA centre frequency, at least 45 dB. 800 MHz Dual-Mode CDMA Cellular Telephones RSS-129.*

*(b) for all offset frequencies greater than 1.98 MHz from the CDMA centre frequency, at least 60 dB.*

*(c) for all offset frequencies not allocated to the same operator system, at least 60 dB or -13 dBm, whichever is less stringent.*

*(2) In any 30 kHz outside the cellular band, the attenuation shall be at least  $43+10 \log_{10}$  (mean output power in watts) or 70, dB, whichever is the less stringent.*

### 4.4.1 Test Method

Configure the BTS via the BTS controller to enable the Compact RM to transmit at maximum rated power for each of the carrier configurations one, two and three carrier in the Baseband modulation formats IS-95. Measurements will be made on channels at the bottom and top of the duplexer band. The following spectrum analyzer settings are to be used for the measurement of the antenna port (DPM) spurious emissions:

#### 4.4.1.1 Adjacent 1MHz to indicated cellular band (Upper and Lower)

**Table 30 : Adjacent 750 KHz and 1.98 MHz Spectrum Analyze Settings**

Setting	1 Carrier	2 Carrier	3 Carrier
Resolution Bandwidth <sup>a</sup> :	30 kHz	30 kHz	30 kHz
Video Bandwidth (3x RBW)	100 kHz	100 kHz	100 kHz
Video Average	10 Averages	10 Averages	10 Averages
Span	Set accordingly	Set accordingly	Set accordingly
Detector	RMS	RMS	RMS
Attenuation	30 dB	30 dB	30 dB
Ref. Level	35 dBm	35 dBm	35 dBm
Ref. Level Offset	31-34.5 dB	31-34.5 dB	31-34.5 dB

- a. If the spectrum analyze can not be set to the specified RBW the next highest RBW should be used and all measurements corrected to the specified RBW

All spectrum analyzer settings were coupled as per the manufacturers recommendations to improve measurement time, without compromising data.

### 4.4.2 Test Setup

The set-up required for the Compact RM Antenna Port (DPM) Spurious Emission test is illustrated in Figure 4.

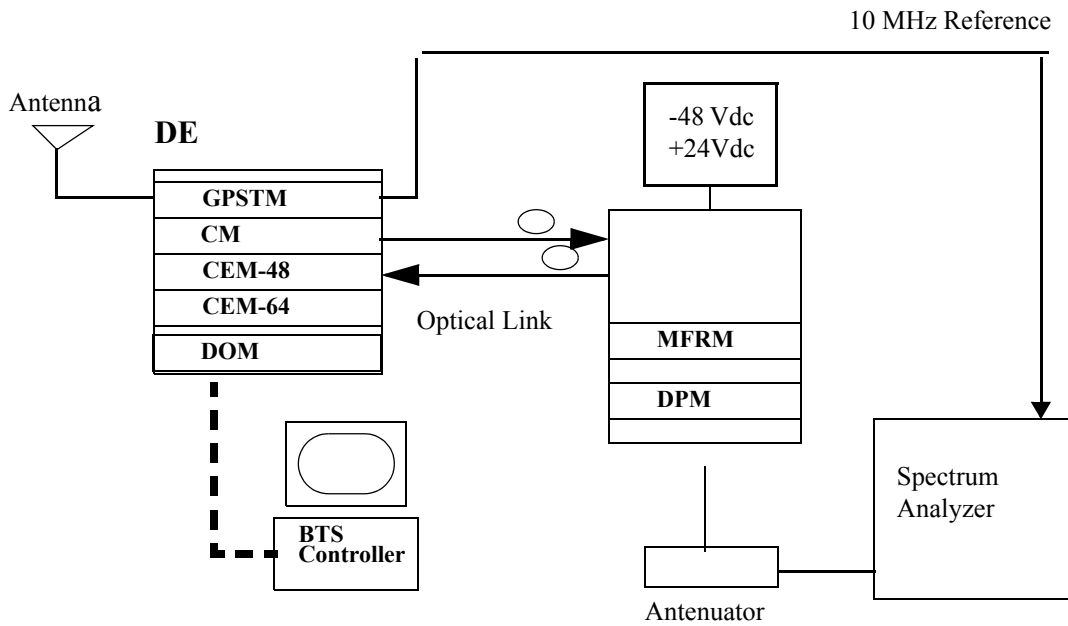

**Figure 4 : Test Setup for Spurious Emissions Measurement**

### 4.4.3 Test Results

**Table 31 : Industry Canada Suppression inside cellular band MFRM 800 MHz Radio  
Antenna Port IS95, 1 Carrier band A'' \***

Frequency (MHz)	Spurious Emissions Level (dBm)	Limit for 45 dBc/ 30KHz (dBm)	Margin to IC Limit of 45 dBc/ 30KHz (dB)
	1Carrier IS-95	1Carrier	1 Carrier
Ch1015 750KHz offset at lower side	-19.98	2.3	22.28
Ch1015 750KHz offset at upper side	-21.01	2.3	23.31
		Limit for 60 dBc/ 30KHz (dBm)	Margin to IC Limit of 60 dBc/ 30KHz (dB)
Ch1015 1.98MHz offset at lower side	-32.78	-12.7	20.08
Ch1015 1.98MHz offset at upper side	-30.98	-12.7	18.28

\*. See Appendix A - Single Carrier IS-95 Spurious Emission

**Table 32 : Industry Canada Suppression inside cellular band MFRM 800 MHz Radio  
 Antenna Port IS95, 3 Carrier band A'' and A<sup>a</sup>**

Frequency (MHz)	Spurious Emissions Level (dBm)	Limit for 45 dBc/ 30KHz (dBm)	Margin to IC Limit of 45 dBc/ 30KHz (dB)
	3Carrier IS-95	3Carrier	3Carrier
Ch1015, 33, 74 750KHz offset at lower side	-25.21	2.3	27.51
Ch1015, 33, 74 750KHz offset at upper side	-25.02	2.3	27.32
		Limit for 60 dBc/ 30KHz (dBm)	Margin to IC Limit of 60 dBc/ 30KHz (dB)
Ch1015, 33, 74 1.98MHz offset at lower side	-37.3	-12.7	24.6
Ch1015, 33, 74 1.98MHz offset at upper side	-35.68	-12.7	22.98

a. See Appendix C - Three Carrier IS-95 Spurioud Emission



**Table 33 : Industry Canada Suppression inside cellular band MFRM 800 MHz Radio  
 Antenna Port IS95, 1 Carrier band B'**

Frequency (MHz)	Spurious Emissions Level (dBm)	Limit for 45 dBc/30KHz (dBm)	Margin to IC Limit of 45 dBc/ 30KHz (dB)
	1Carrier IS-95	1Carrier	1Carrier
Ch 742 750KHz offset at lower side	-19.99	2.3	22.29
Ch 742 750KHz offset at upper side	-20.81	2.3	23.11
		Limit for 60 dBc/30KHz (dBm)	Margin to IC Limit of 60 dBc/ 30KHz (dB)
Ch 742 1.98MHz offset at lower side	-31.53	-12.7	18.83
Ch 742 1.98MHz offset at upper side	-30.59	-12.7	17.89

**Table 34 : Industry Canada Suppression inside cellular band MFRM 800 MHz Radio  
 Antenna Port IS856 16QAM, 1 Carrier band B <sup>a</sup>**

Frequency (MHz)	Spurious Emissions Level (dBm)	Limit for 45 dBc/30KHz (dBm)	Margin to IC Limit of 45 dBc/30KHz (dB)
	1Carrier IS-856 16QAM	1Carrier	1Carrier
Ch 358 750KHz offset at lower side	-20.59	2.3	22.89
Ch 358 750KHz offset at upper side	-21.18	2.3	23.48
		Limit for 60 dBc/30KHz (dBm)	Margin to IC Limit of 60 dBc/30KHz (dB)
Ch 358 1.98MHz offset at lower side	-31.51	-12.7	18.81
Ch 358 1.98MHz offset at upper side	-31.29	-12.7	18.59

a. See Appendix D One Carrier IS-856 16QAM Spurious Emission

**Table 35 : Industry Canada Suppression inside cellular band MFRM 800 MHz Radio  
 Antenna Port IS856 16QAM, 3 Carriers band B <sup>a</sup>**

Frequency (MHz)	Spurious Emissions Level (dBm)	Limit for 45 dBc/30KHz (dBm)	Margin to IC Limit of 45 dBc/ 30KHz (dB)
	3Carriers IS-856 16QAM	3Carriers	3Carriers
Ch 358, 399, 440 750KHz offset at lower side	-24.84	2.3	27.14
Ch 358, 399, 440 750KHz offset at upper side	-24.70	2.3	26.37
		Limit for 60 dBc/30KHz (dBm)	Margin to IC Limit of 60 dBc/ 30KHz (dB)
Ch 358, 399, 440 1.98MHz offset at lower side	-35.86	-12.7	23.16
Ch 358, 399, 440 1.98MHz offset at upper side	-35.52	-12.7	22.82

a. See Appendix E Three Carriers IS-856 16QAM Spurious Emission

## 4.5 Frequency Stability

### 4.5.1 Frequency Stability Requirements

#### FCC Part 2.1055

*(a) The frequency stability shall be measured with variation of ambient temperature as follows:*

*(1) From -30 to +50 centigrade for all equipment except that specified in subparagraphs (2) and (3) of this paragraph.*

*(b) Frequency measurements shall be made at the extremes of the specified temperature range and at intervals of not more than 10 centigrade through the range. A period of time sufficient to stabilize all of the components of the oscillator circuit at each temperature level shall be allowed prior to frequency measurement. The short term transient effects on the frequency of the transmitter due to keying (except for broadcast transmitters) and any heating element cycling normally occurring at each ambient temperature level also shall be shown. Only the portion or portions of the transmitter containing the frequency determining and stabilizing circuitry need be subjected to the temperature variation test.*

*(d) The frequency stability shall be measured with variation of primary supply voltage as follows:*

*(1) Vary primary supply voltage from 85 to 115 percent of the nominal value for other than hand carried battery equipment.*

*(2) For hand carried, battery powered equipment, reduce primary supply voltage to the battery operating end point which shall be specified by the manufacturer.*

*(3) The supply voltage shall be measured at the input to the cable normally provided with the equipment, or at the power supply terminals if cables are not normally provided. Effects on frequency of transmitter keying (except for broadcast transmitters) and any heating element cycling at the nominal supply voltage and at each extreme also shall be shown.*

*(e) When deemed necessary, the Commission may require tests of frequency stability under conditions in addition to those specifically set out in paragraphs (a), (b), (c) and (d) of this section. (For example, measurements showing the effect of proximity to large metal objects, or of various types of antennas, may be required for portable equipment.)*

#### FCC Part 22.355 Frequency Tolerance

*The carrier frequency of each transmitter in the 821-896 MHz Frequency range, must be maintained within 1.5ppm tolerance, according to table C-1 of this section (22.355)*

### 4.5.2 Test Procedure

The test equipment was configured as shown in figure 5.

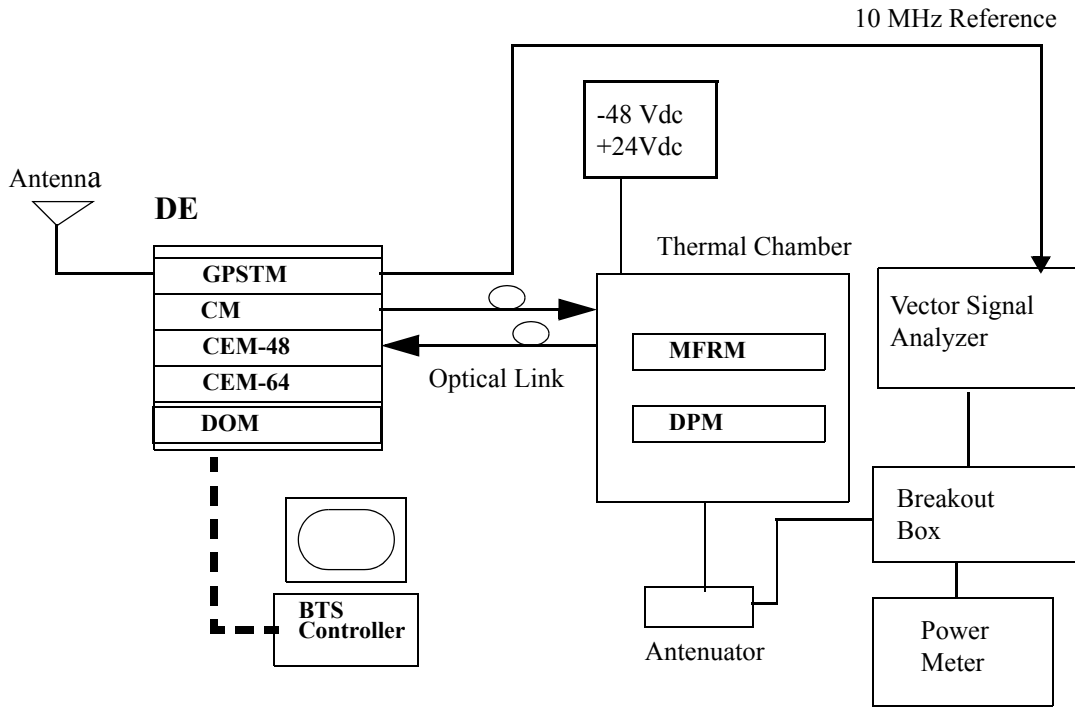

**Figure 5 : Test configuration for Frequency Stability**

### 4.5.3 Frequency Results

The frequency measured 881.97 MHz. Operating temperature for the MFRM 800 MHz is from -30°C to +50°C. The VSA set at 10 average, at each temperature 30 samples were collected

**Table 36 : Test results for Frequency Stability versus Power supply Voltage at 25C**

Voltage (Vdc)	Maximum Carrier Frequency Deviation (PPM)	Maximum Carrier Frequency Deviation (Hz)
40	0.00462	4.08
48 nominal	0.00453	4.00
56	0.00593	5.23

**Table 36 : Test results for Frequency Stability versus Power supply Voltage at 25C**

Voltage (Vdc)	Maximum Carrier Frequency Deviation (PPM)	Maximum Carrier Frequency Deviation (Hz)
20	0.00263	2.32
24 nominal	0.00293	2.58
28	0.00361	3.19

**Table 37 : Test results for Frequency Stability versus Temperature at -48V operation**

Temperature (°C)	Maximum Carrier Frequency Deviation (PPM)	Maximum Carrier Frequency Deviation (Hz)
-30	0.00475	4.19
-20	0.00464	4.09
-10	0.00479	4.22
0	0.00501	4.42
10	0.00404	3.57
20	0.00632	5.58
30	0.00471	4.16
40	0.00347	3.06
50	0.00413	3.64

**Table 38 : Test results for Frequency Stability versus Temperature at 24V operation**

Temperature (°C)	Maximum Carrier Frequency Deviation (PPM)	Maximum Carrier Frequency Deviation (Hz)
-30	0.00212	1.87
-20	0.00293	2.59
-10	0.00233	2.05
0	0.00474	4.18
10	0.00277	2.44
20	0.00349	3.08
30	0.00305	2.69
40	0.00349	3.07
50	0.00319	2.81

## 5 Appendix A - Single Carrier IS-95 Spurious Emission

### Single Chan 1015 IS95 Spurious Emissions at the 800 MHz MFRM1 (Maple) Ant. Port one Carrier Band A and A" IS95

#### Occupied Bandwidth Ch 1015 A''

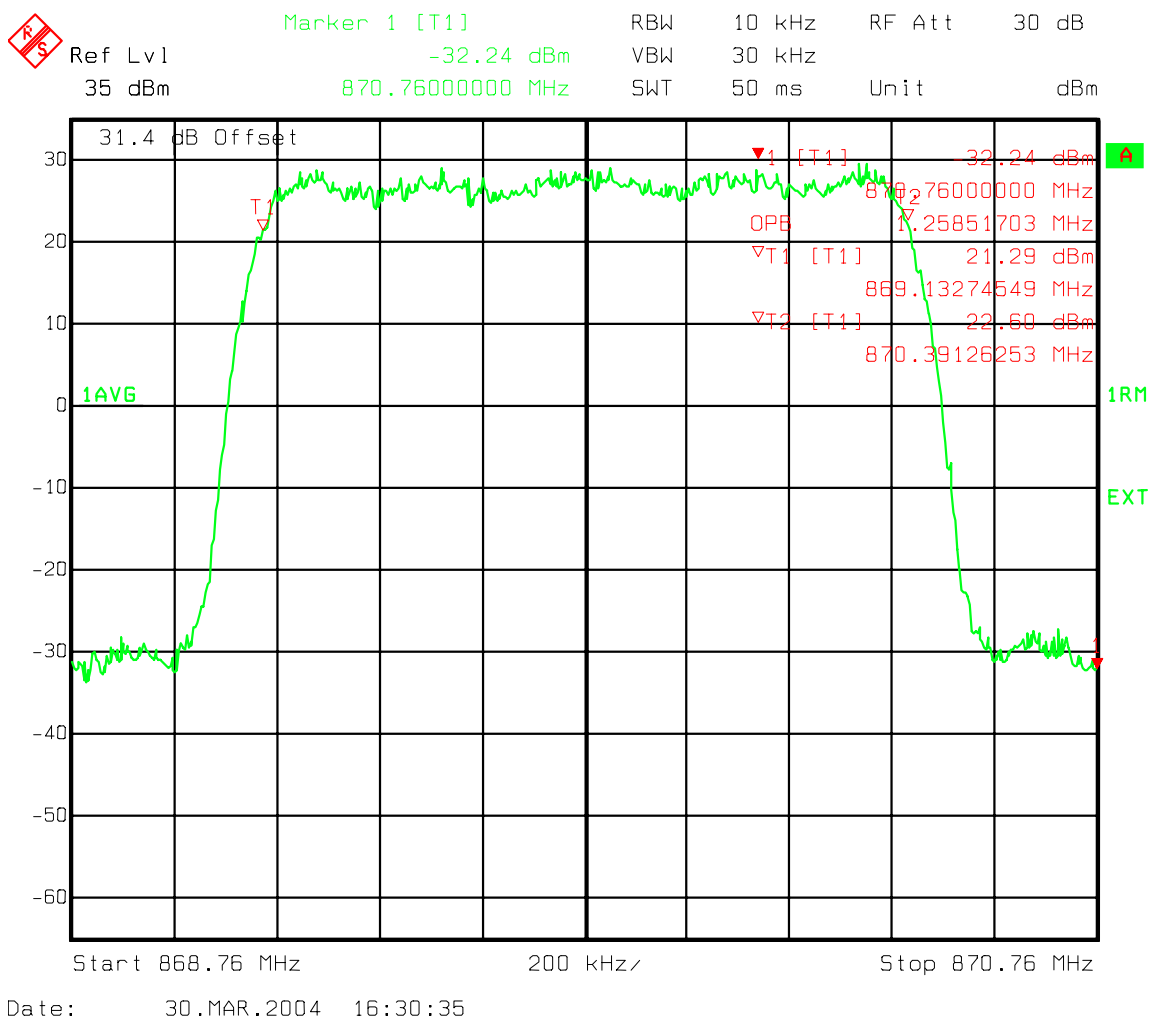
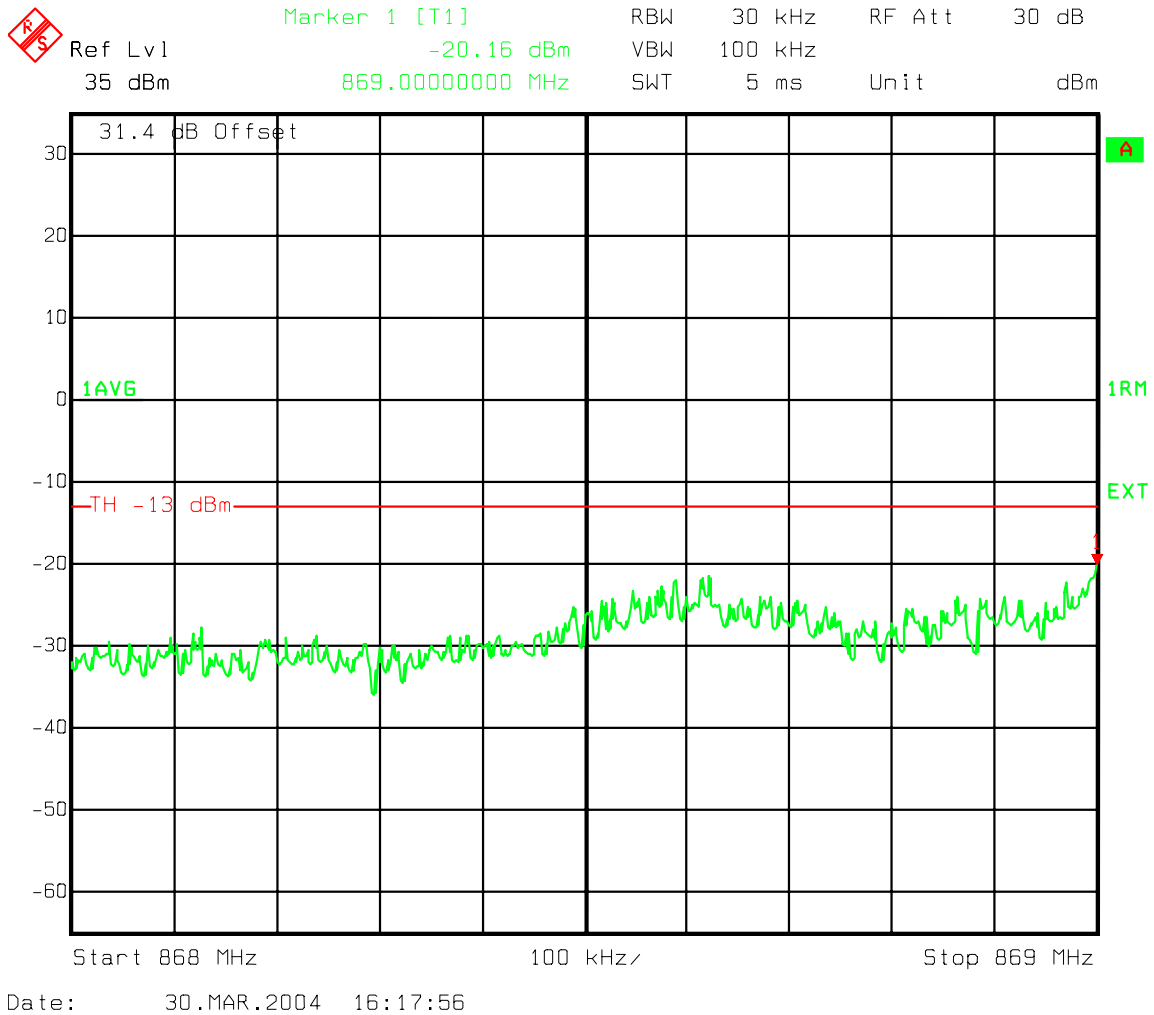

**Figure 6 : 1 Carrier - Occupied Bandwidth Channel 1015**



**Single Chan 1015 IS95 Spurious Emissions at the 800 MHz MFRM1 (Maple) Ant.  
Port one Carrier band A and A'' IS95**

**A'' Band Ch 1015 IS95 Adjacent 1 MHz Lower emissions 868-869 MHz**



**Figure 7 : One Carrier - A'' Band Ch 1015 IS95 Adjacent 1 MHz Lower emissions 868-869 MHz**

**Single Chan 1015 IS95 Spurious Emissions at the 800 MHz MFRM1 (Maple) Ant.  
 Port one Carrier band A and A'' IS95**

**Ch1015 IS95 Lower A'' Band Adjacent to outside edge 12.5kHz Band Channel  
 Power**

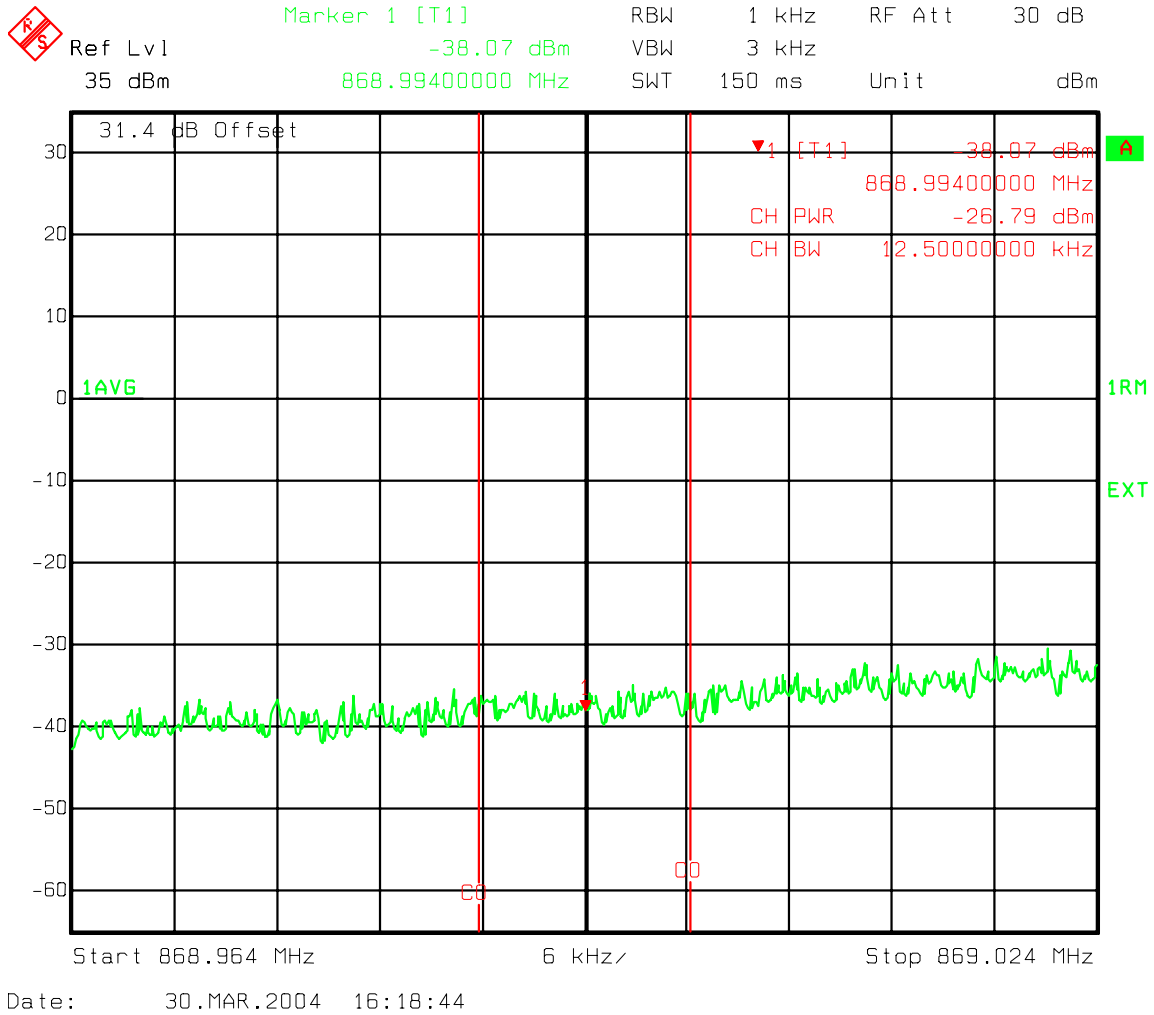

**Figure 8 : One Carrier - Ch1015 IS95 Lower A'' Band Adjacent to outside edge 12.5kHz  
 band Channel Power**

**Single Chan 1015 IS95 Spurious Emissions at the 800 MHz MFRM1 (Maple) Ant.  
Port one Carrier band A and A'' IS95**

**Ch 308 Upper A Band adjacent 1MHz band emissions**

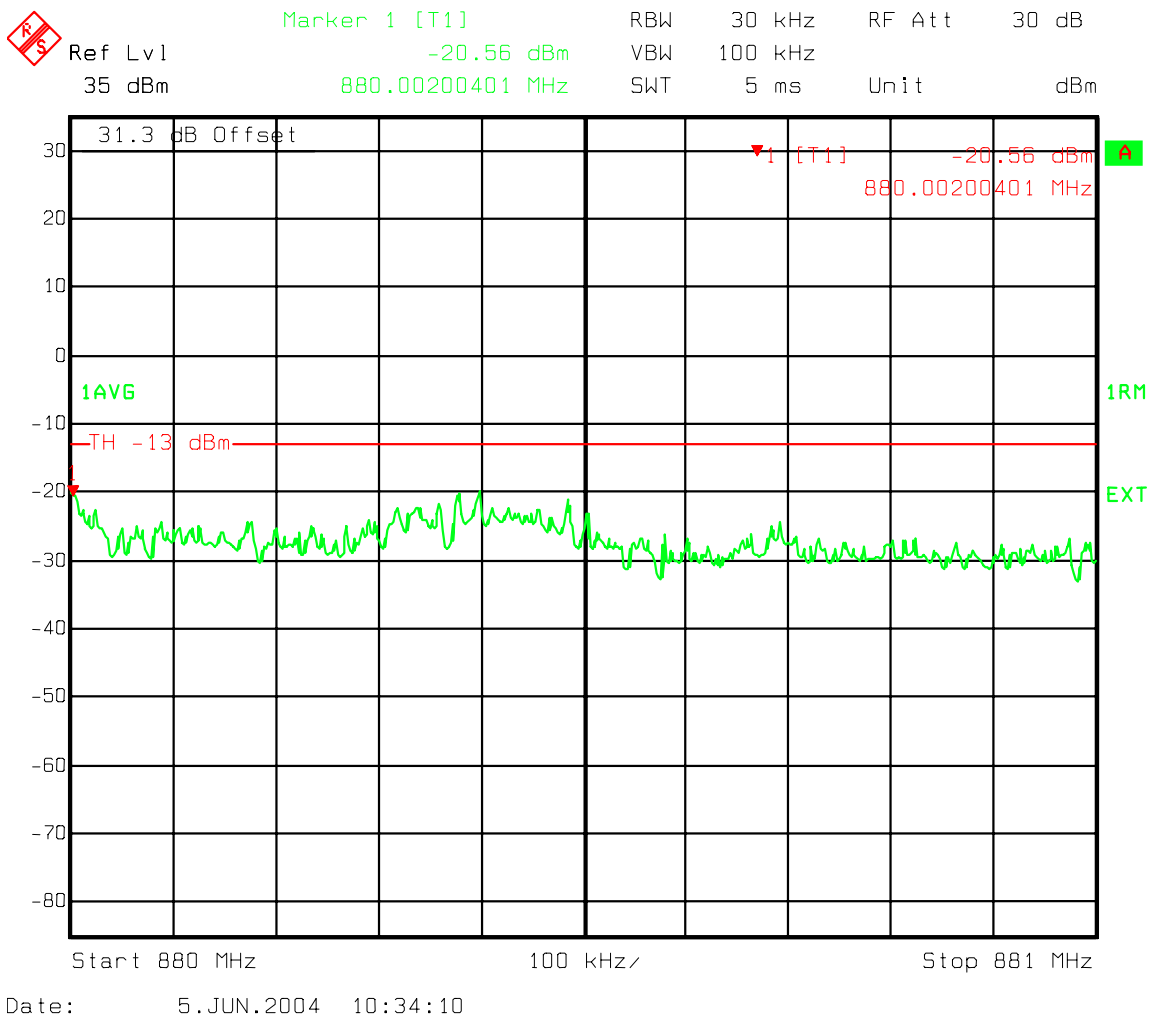

**Figure 9 : One Carrier - Ch 308 Upper A Band adjacent 1MHz band emissions**

**Single Chan 1015 IS95 Spurious Emissions at the 800 MHz MFRM1 (Maple) Ant.  
 Port one Carrier band A and A'' IS95**

**Ch 308 Upper A Band adjacent to outside edge 12.5 kHz band Channel power**

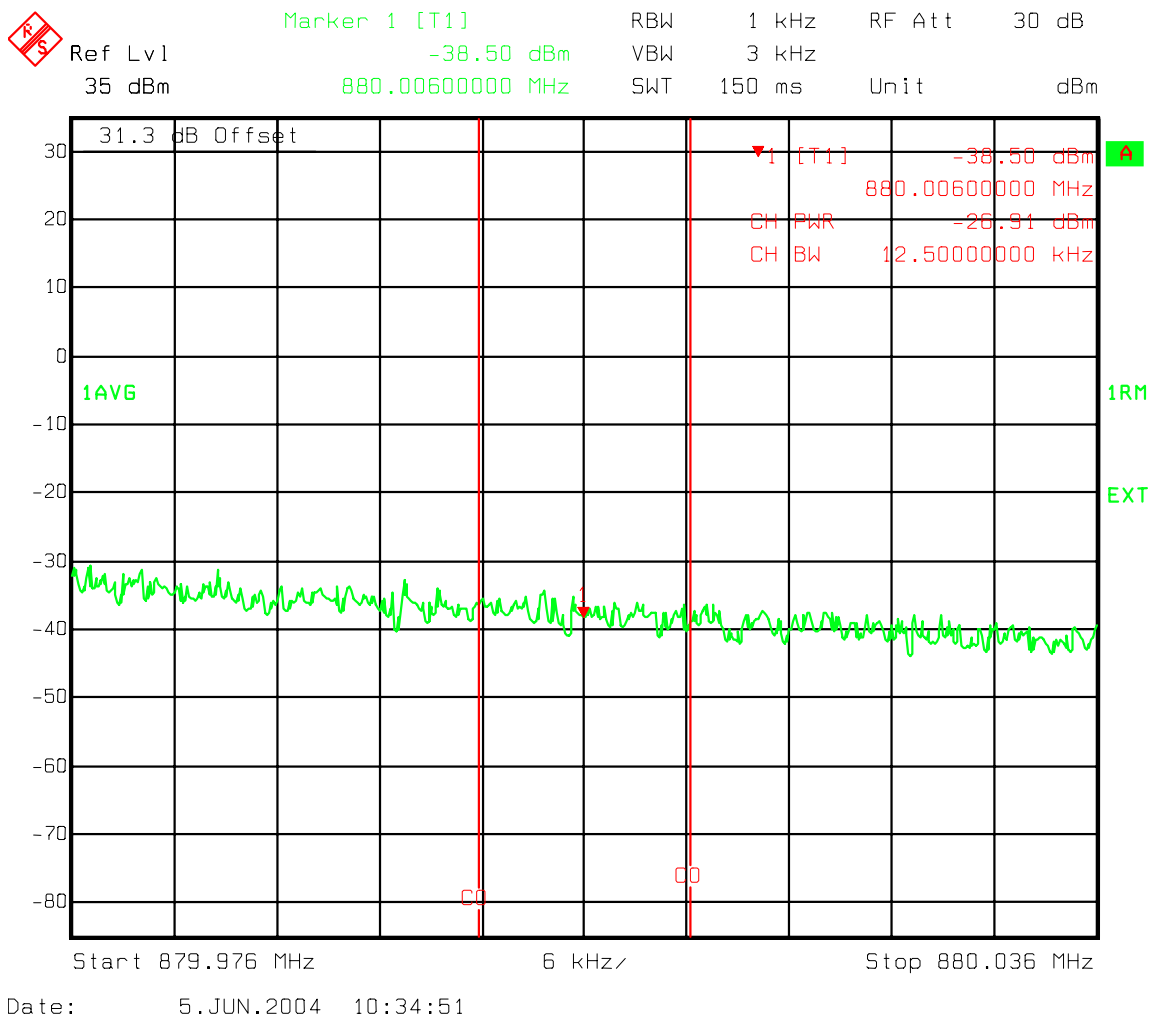

**Figure 10 : One Carrier - Ch 308 Upper A Band adjacent to outside edge 12.5 kHz band Channel power**

**Single Chan 1015 IS95 Spurious Emissions at the 800 MHz MFRM1 (Maple) Ant.  
Port one Carrier band A and A'' IS95**

**Industry Canada Lower 750 kHz offset 30 kHz Chan Power Ch 1015**

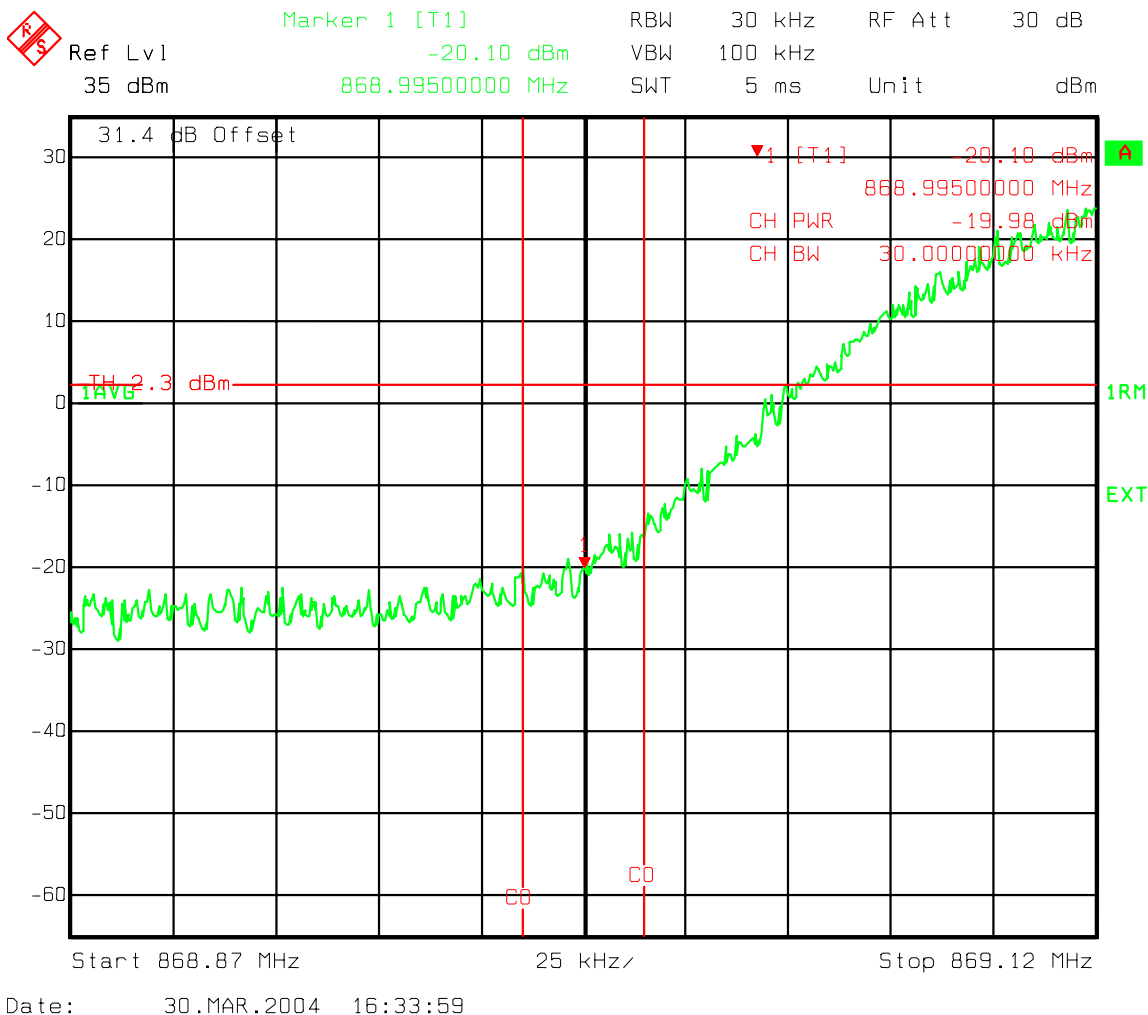

**Figure 11 : One Carrier - Industry Canada Lower 750 kHz offset 30 kHz Chan Power Ch 1015**

**Single Chan 1015 IS95 Spurious Emissions at the 800 MHz MFRM1 (Maple) Ant.  
 Port one Carrier band A and A'' IS95**

**Industry Canada Upper 750 kHz offset 30 kHz Chan Power Ch 1015**

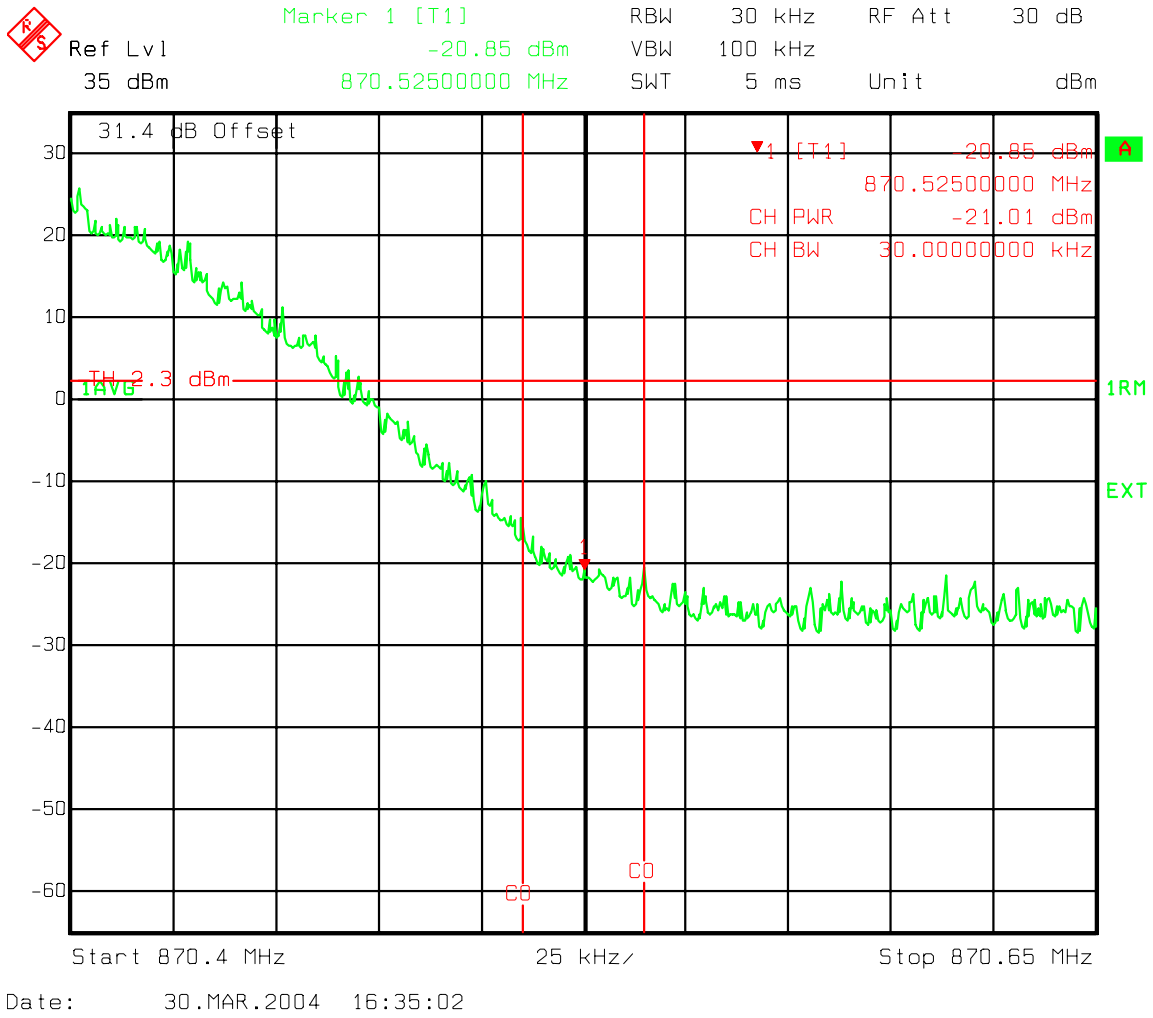

**Figure 12 : One Carrier - Industry Canada Upper 750 kHz offset 30 kHz Chan Power Ch 1015**

**Single Chan 1015 IS95 Spurious Emissions at the 800 MHz MFRM1 (Maple) Ant.  
 Port one Carrier band A and A'' IS95**

**Industry Canada 1.98 MHz offset Lower 30 kHz Chan Power Ch 1015**

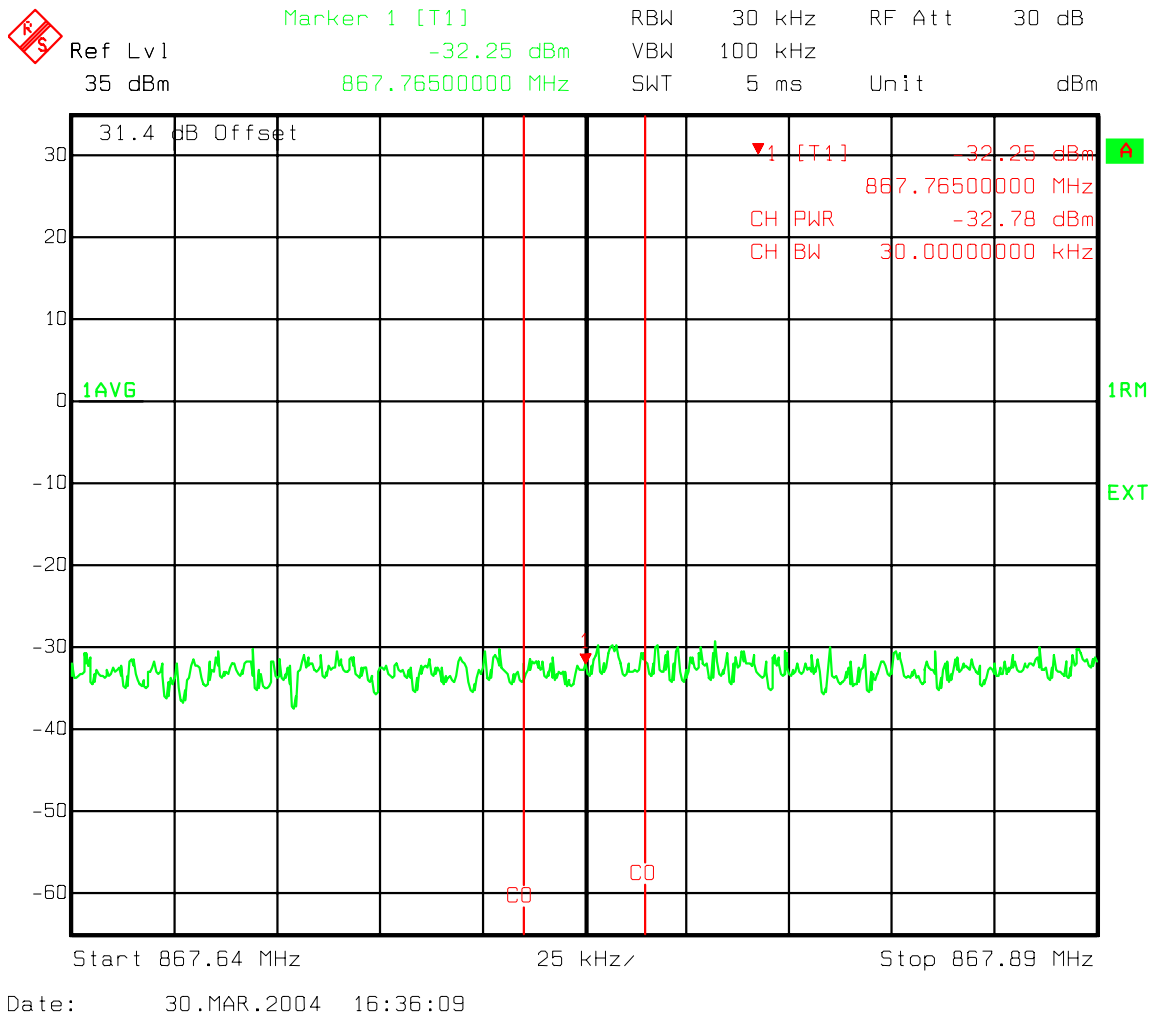

**Figure 13 : One Carrier - Industry Canada 1.98 MHz offset Lower 30 kHz Chan Power Ch 1015**

**Single Chan 1015 IS95 Spurious Emissions at the 800 MHz MFRM1 (Maple) Ant.  
 Port one Carrier band A and A'' IS95**

**Industry Canada 1.98 MHz offset Upper 30 kHz Chan Power Ch 1015**

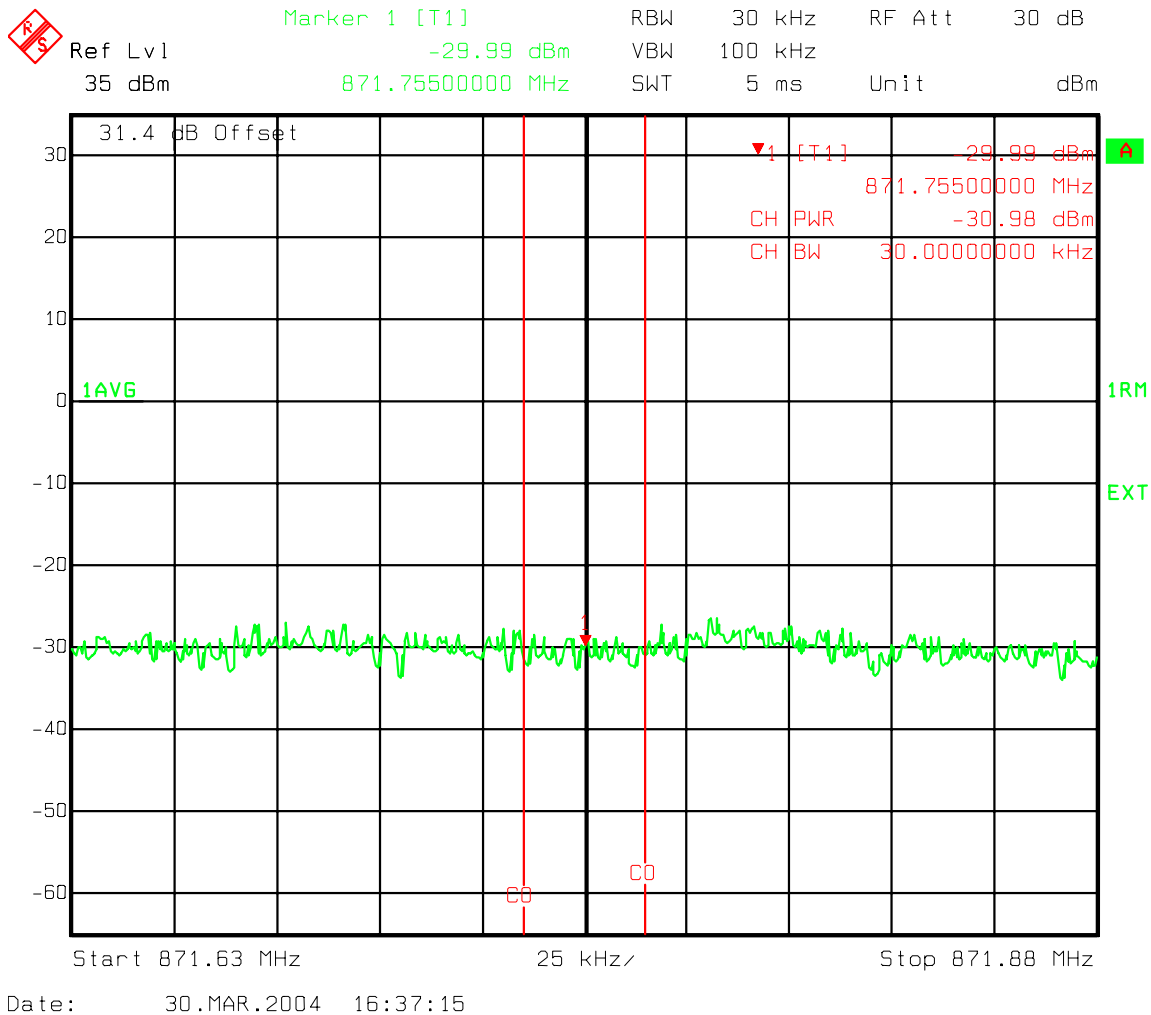

**Figure 14 : One Carrier - Industry Canada 1.98 MHz offset Upper 30 kHz Chan Power Ch 1015**







**Single Chan 1015 IS95 Spurious Emissions at the 800 MHz MFRM1 (Maple) Ant.  
Port one Carrier band A and A'' IS95**

**A'' and a Band IS95 Spurious emissions Upper 1 MHz Band Edge to 1 GHz**

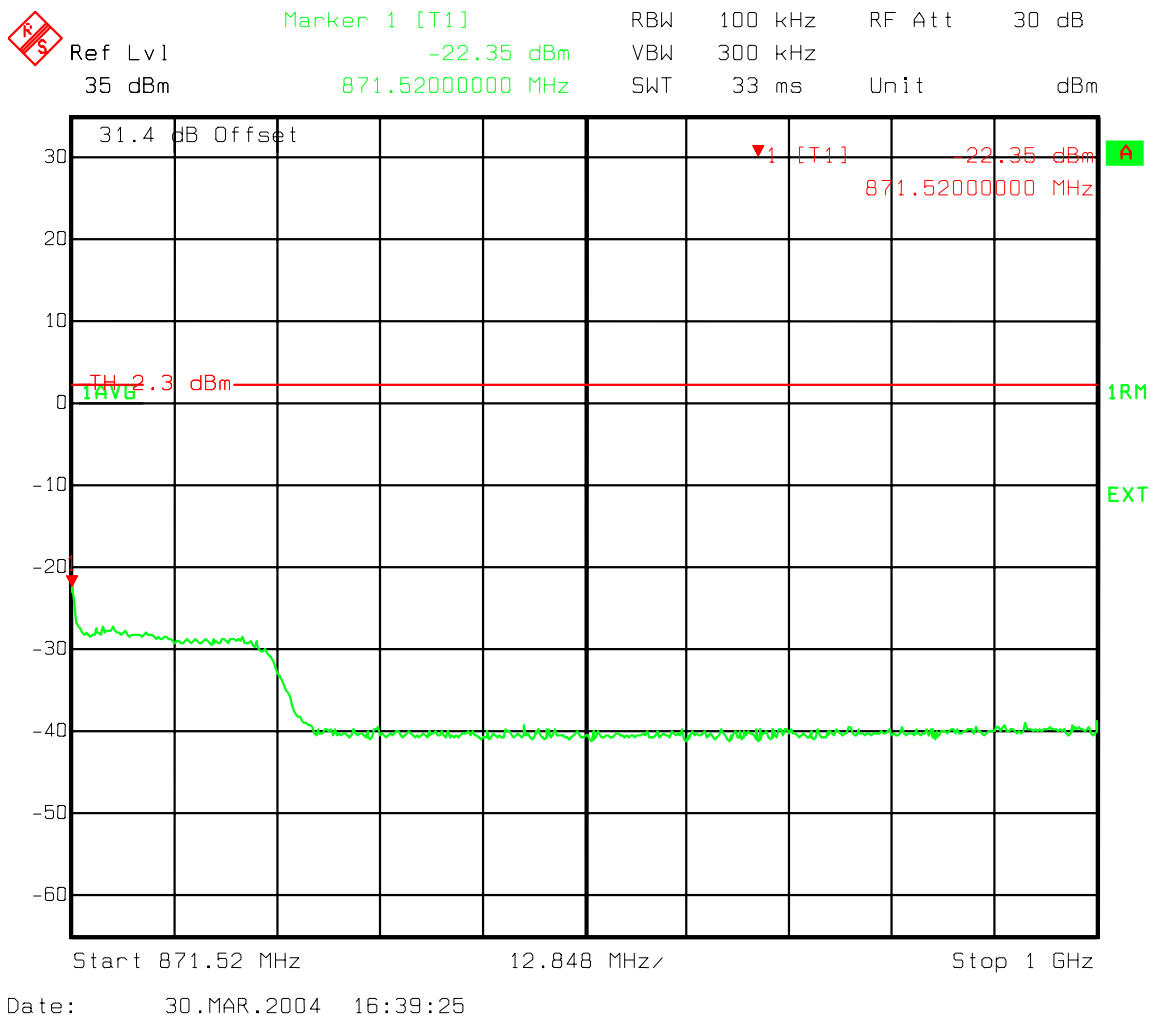

**Figure 17 : One Carrier - A'' and a Band IS95 Spurious emissions Upper 1 MHz Band Edge to 1 GHz**

**Single Chan 1015 IS95 Spurious Emissions at the 800 MHz MFRM1 (Maple) Ant.  
 Port one Carrier band A and A'' IS95**

**A'' and A Band IS95 Spurious emissions 400-1000 MHz**

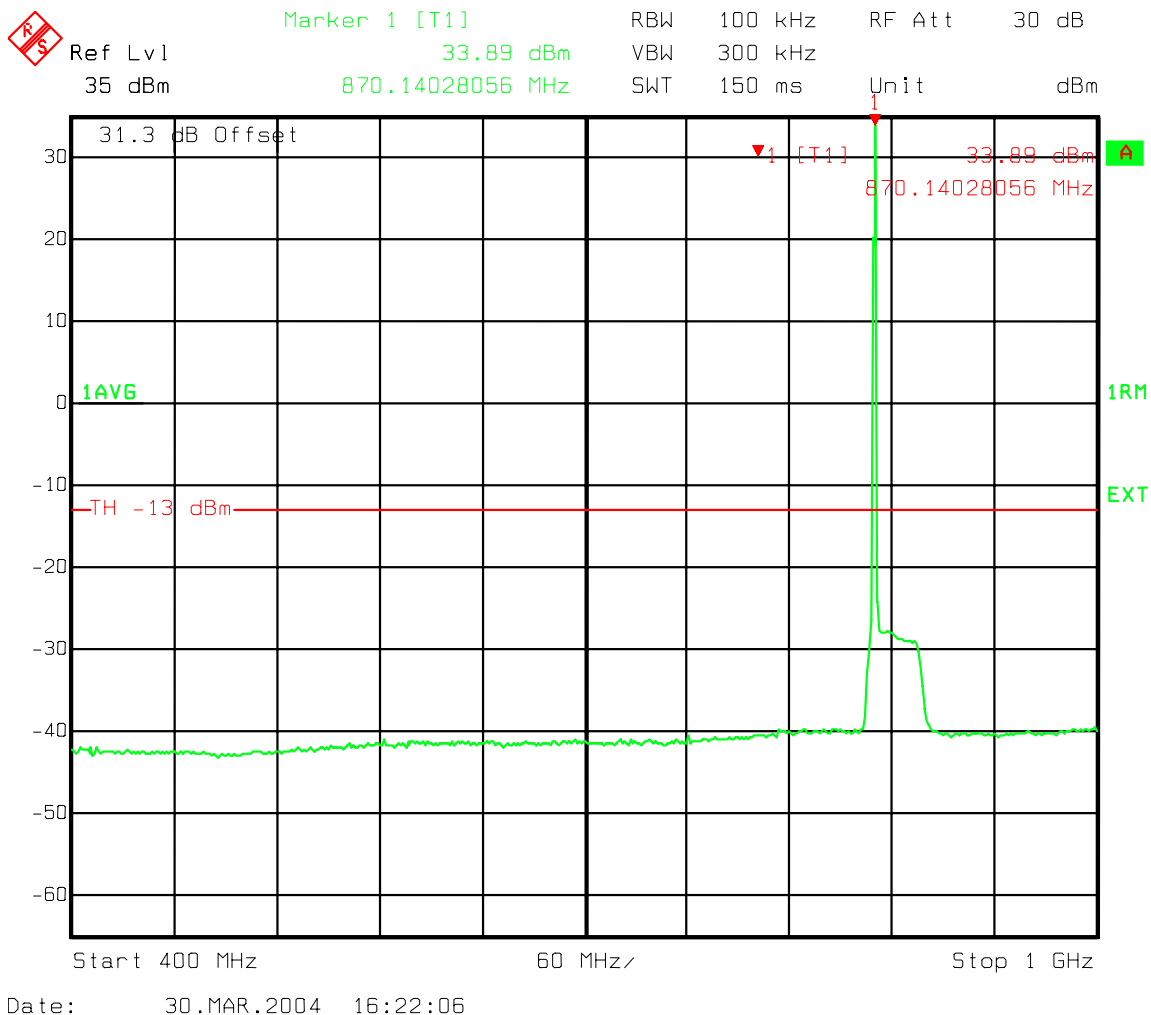

**Figure 18 : One Carrier - A'' and A Band IS95 Spurious emissions 400-1000 MHz**

### Single Chan 1015 IS95 Spurious Emissions at the 800 MHz MFRM1 (Maple) Ant. Port one Carrier band A and A'' IS95

#### A'' and A Band IS95 Spurious emissions 1000-2000 MHz

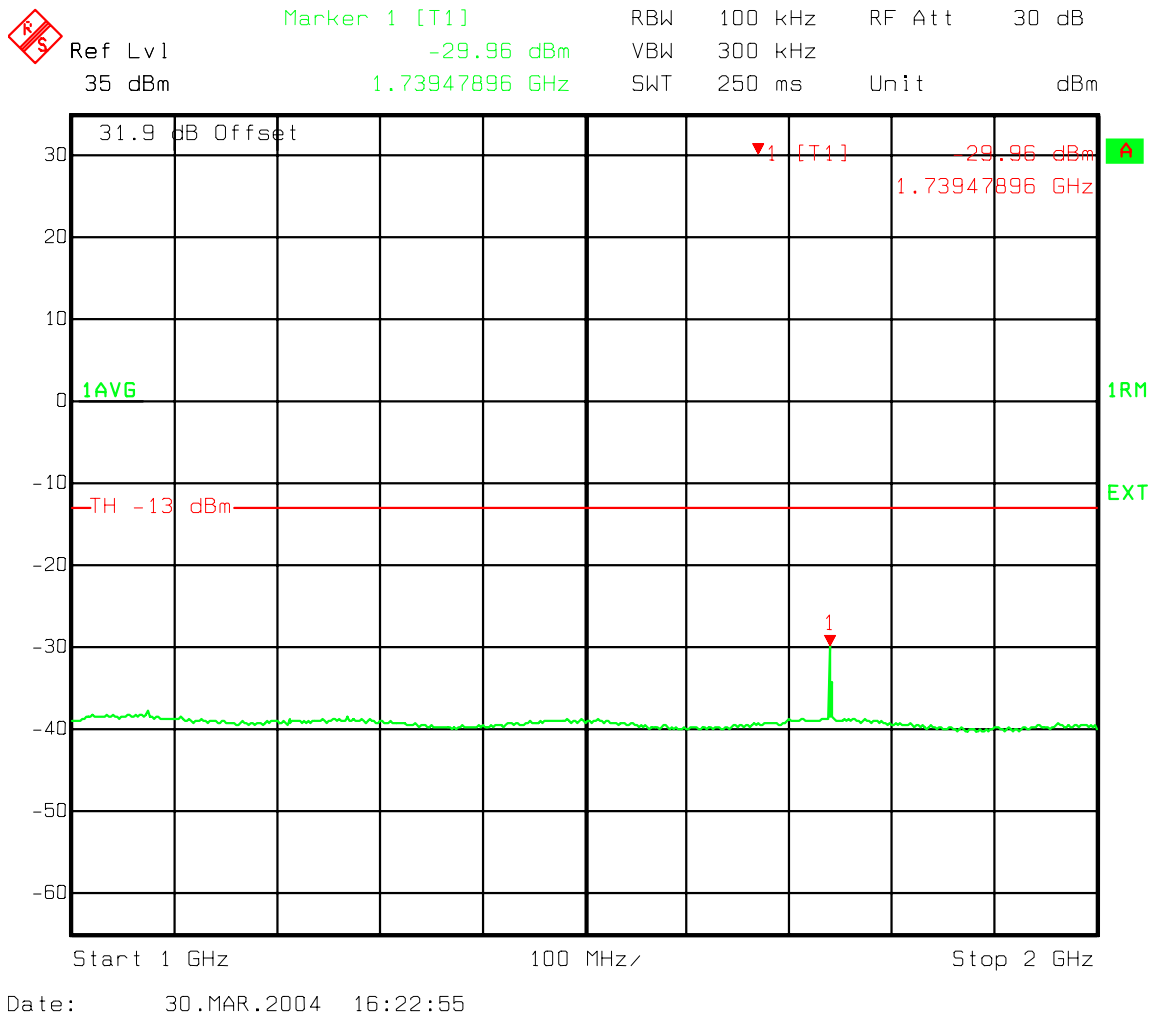

**Figure 19 : One Carrier - A'' and A Band IS95 Spurious emissions 1000-2000 MHz**

**Single Chan 1015 IS95 Spurious Emissions at the 800 MHz MFRM1 (Maple) Ant.  
 Port one Carrier band A and A'' IS95**

**A'' and A Band IS95 Spurious emissions 2000-3000 MHz**

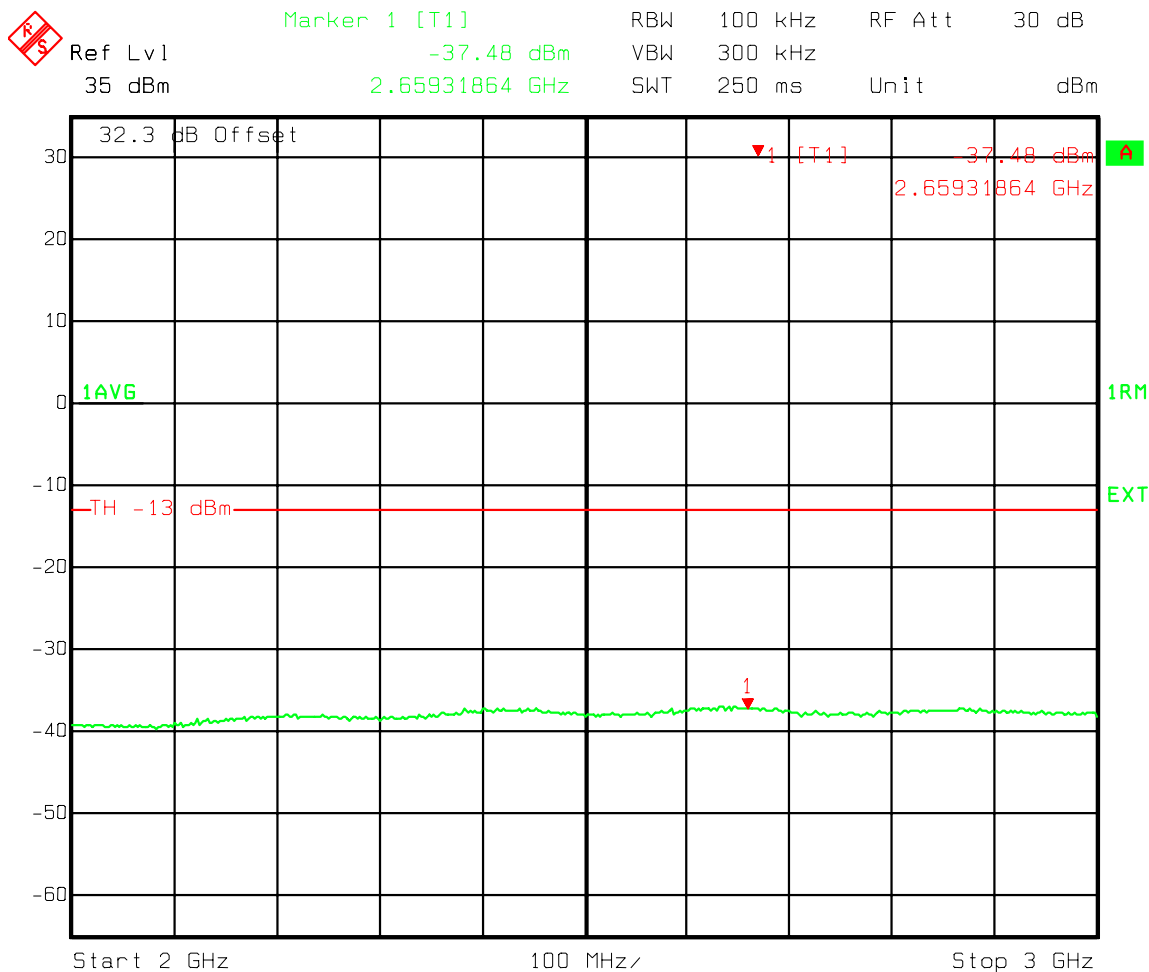

Date: 30.MAR.2004 16:23:46

**Figure 20 : One Carrier - A'' and A Band IS95 Spurious emissions 2000-3000 MHz**

**Single Chan 1015 IS95 Spurious Emissions at the 800 MHz MFRM1 (Maple) Ant.  
 Port one Carrier band A and A'' IS95**

**A'' and A Band IS95 Spurious emissions 3000-4000 MHz**

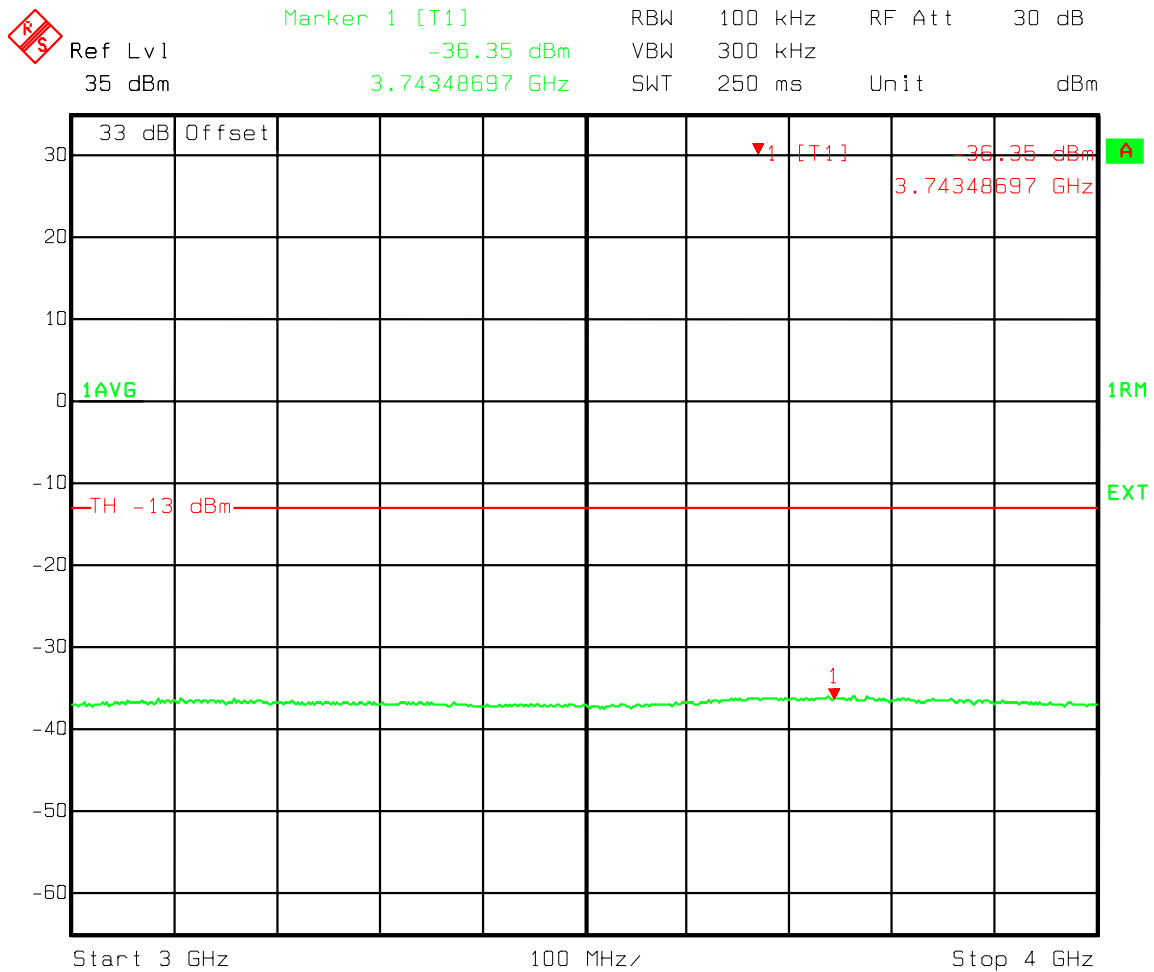

Date: 30.MAR.2004 16:24:36

**Figure 21 : One Carrier - A'' and A Band IS95 Spurious emissions 3000-4000 MHz**





### Single Chan 1015 IS95 Spurious Emissions at the 800 MHz MFRM1 (Maple) Ant. Port one Carrier band A and A'' IS95

#### A'' and A Band IS95 Spurious emissions 5000-6000 MHz

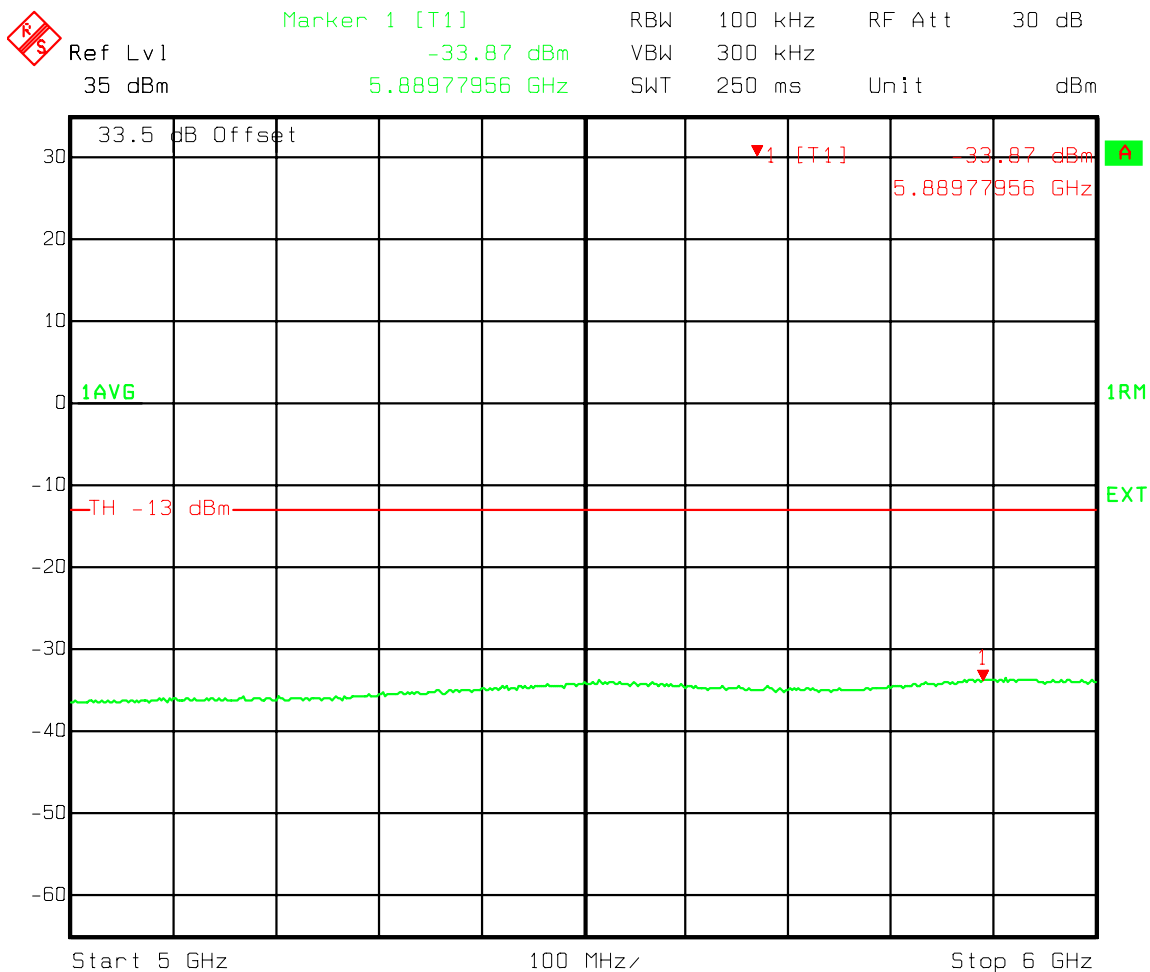

Date: 30.MAR.2004 16:26:17

Figure 23 : One Carrier - A'' and A Band IS95 Spurious emissions 5000-6000 MHz

**Single Chan 1015 IS95 Spurious Emissions at the 800 MHz MFRM1 (Maple) Ant.  
 Port one Carrier band A and A'' IS95**

**A'' and A Band IS95 Spurious emissions 6000-7000 MHz**

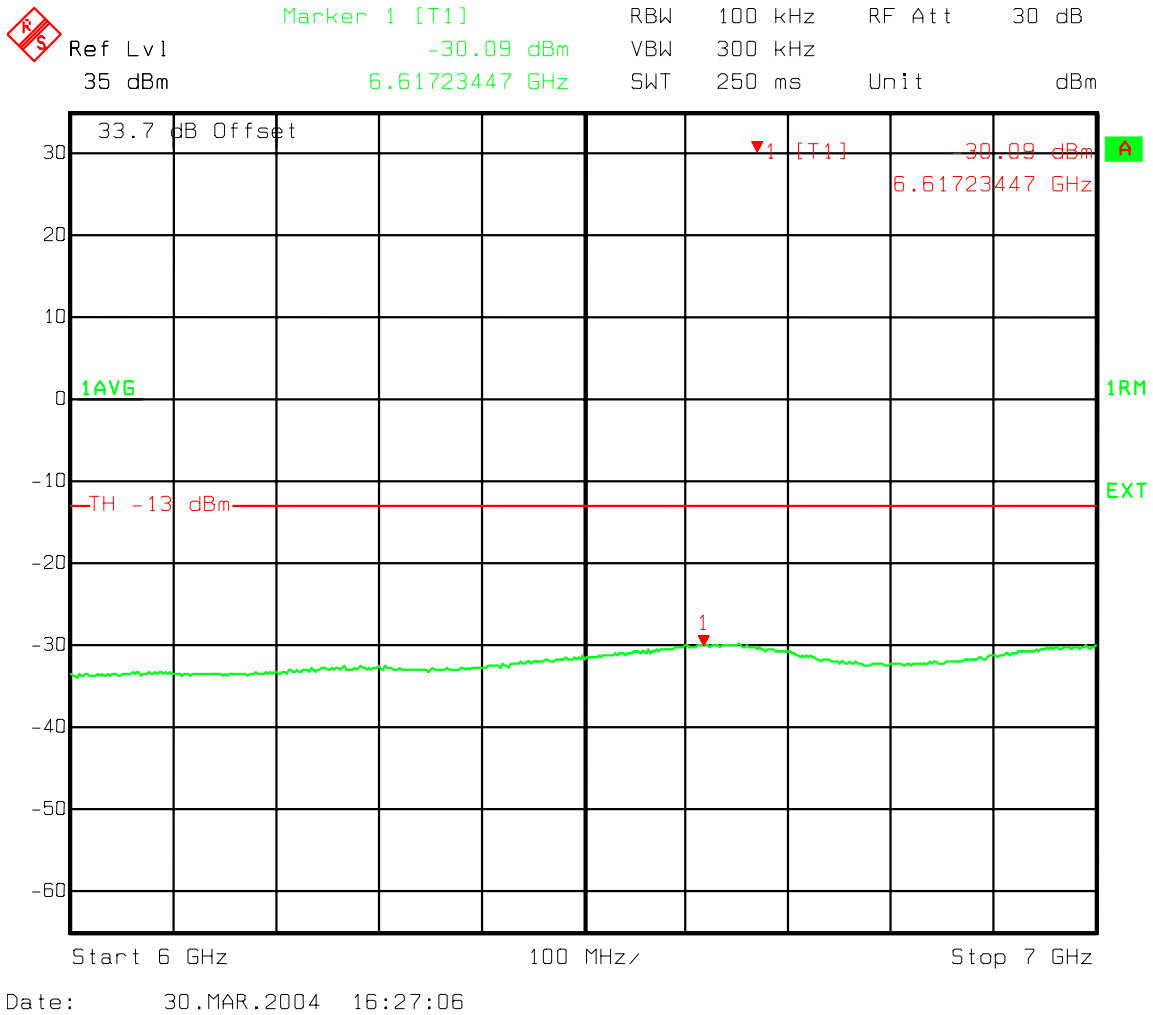

**Figure 24 : One Carrier - A'' and A Band IS95 Spurious emissions 6000-7000 MHz**

**Single Chan 1015 IS95 Spurious Emissions at the 800 MHz MFRM1 (Maple) Ant.  
Port one Carrier band A and A'' IS95**

**A'' and A Band IS95 Spurious emissions 7000-8000 MHz**

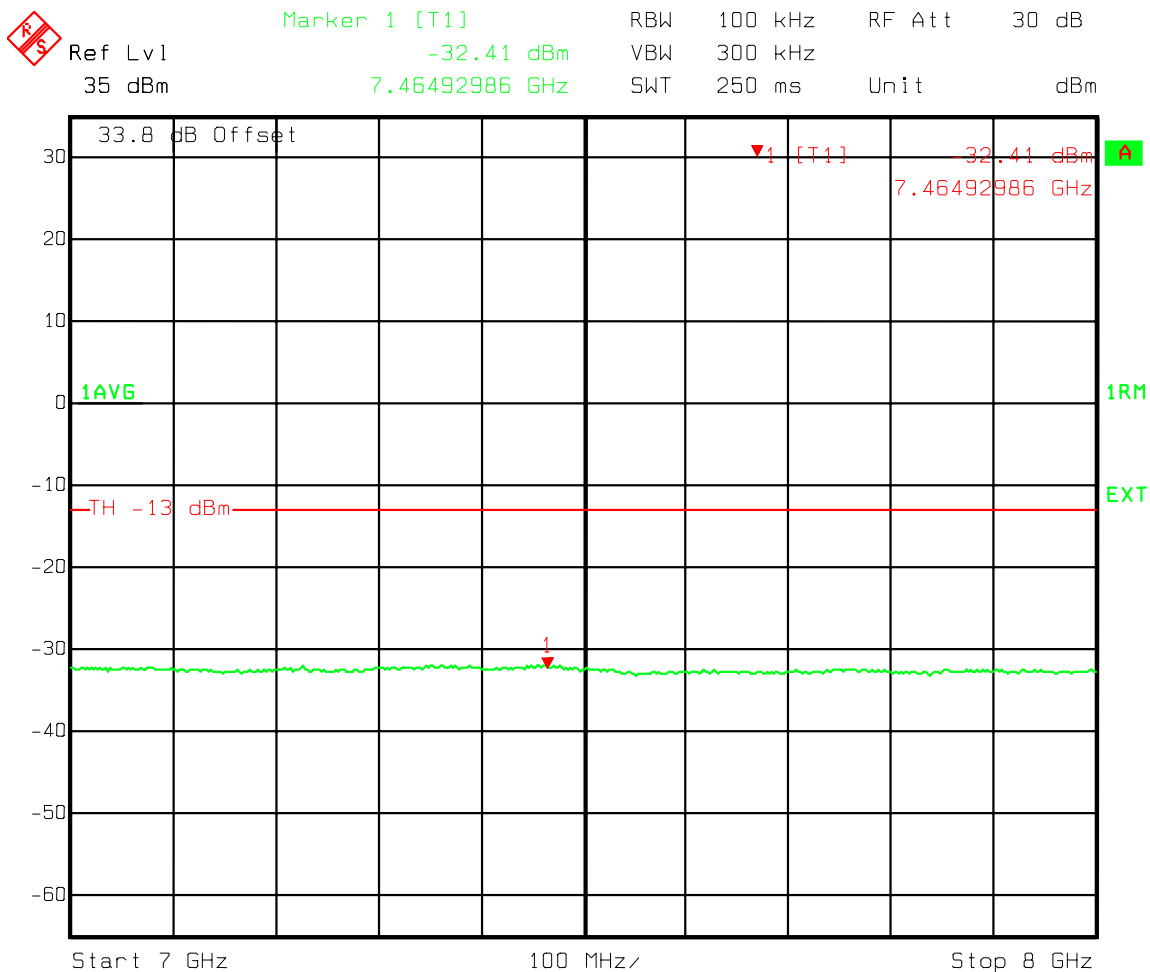

Date: 30.MAR.2004 16:27:58

**Figure 25 : One Carrier - A'' and A Band IS95 Spurious emissions 7000-8000 MHz**

### Single Chan 1015 IS95 Spurious Emissions at the 800 MHz MFRM1 (Maple) Ant. Port one Carrier band A and A'' IS95

#### A'' and A Band IS95 Spurious emissions 8000-9000 MHz

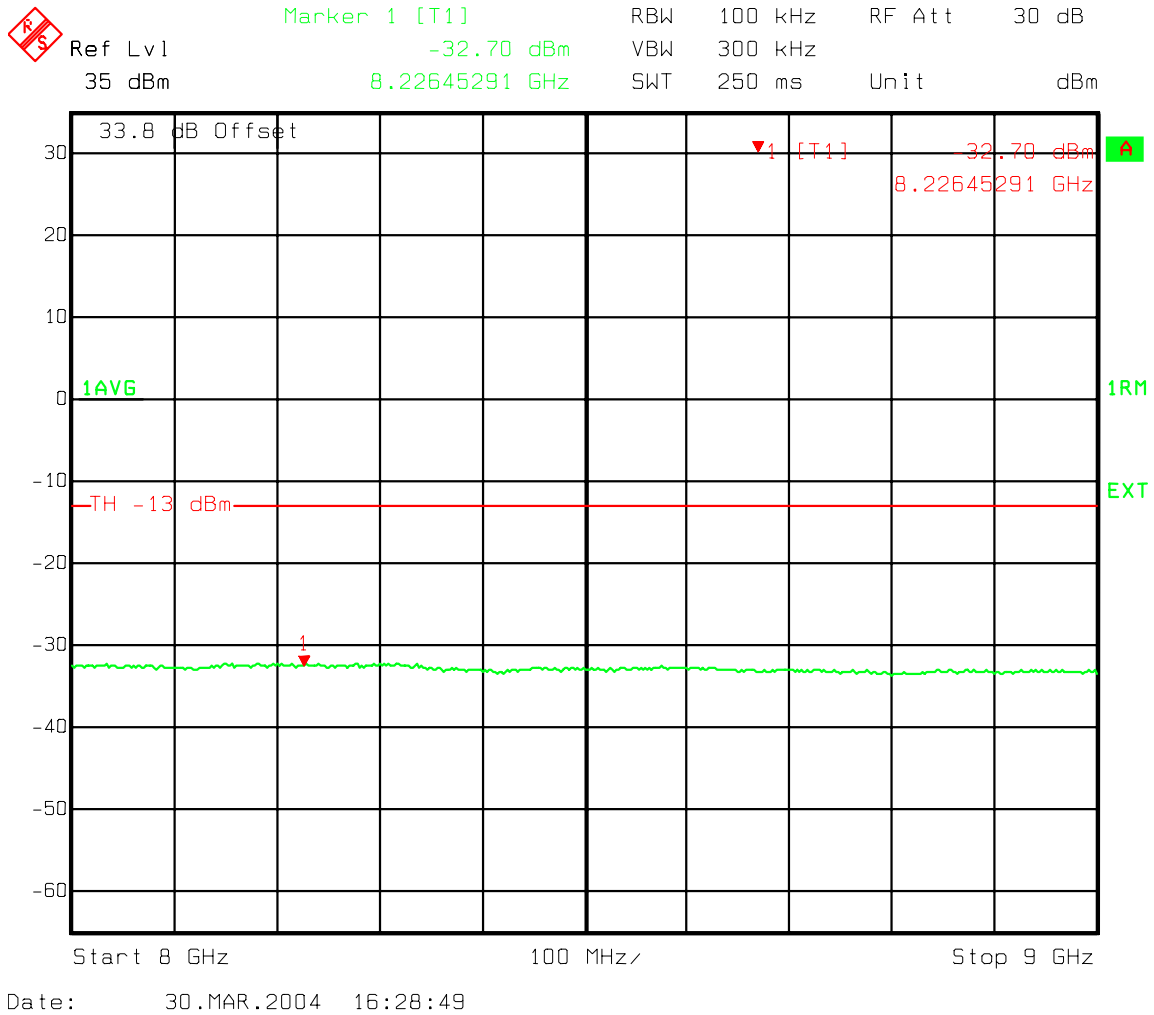
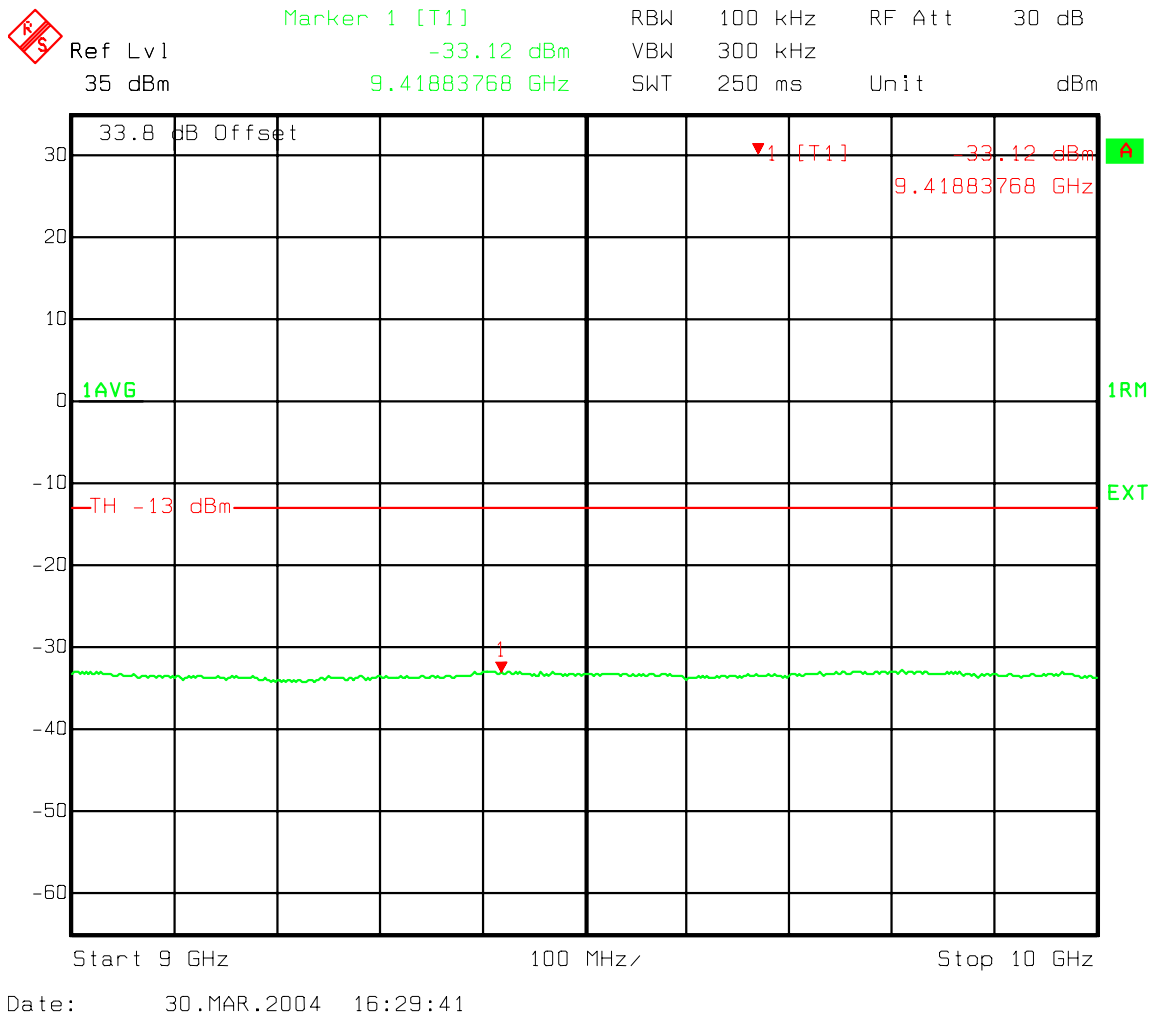

Figure 26 : One Carrier - A'' and A Band IS95 Spurious emissions 8000-9000 MHz

**Single Chan 1015 IS95 Spurious Emissions at the 800 MHz MFRM1 (Maple) Ant.  
Port one Carrier band A and A'' IS95**

**A'' and A Band IS95 Spurious emissions 9000-10000 MHz**

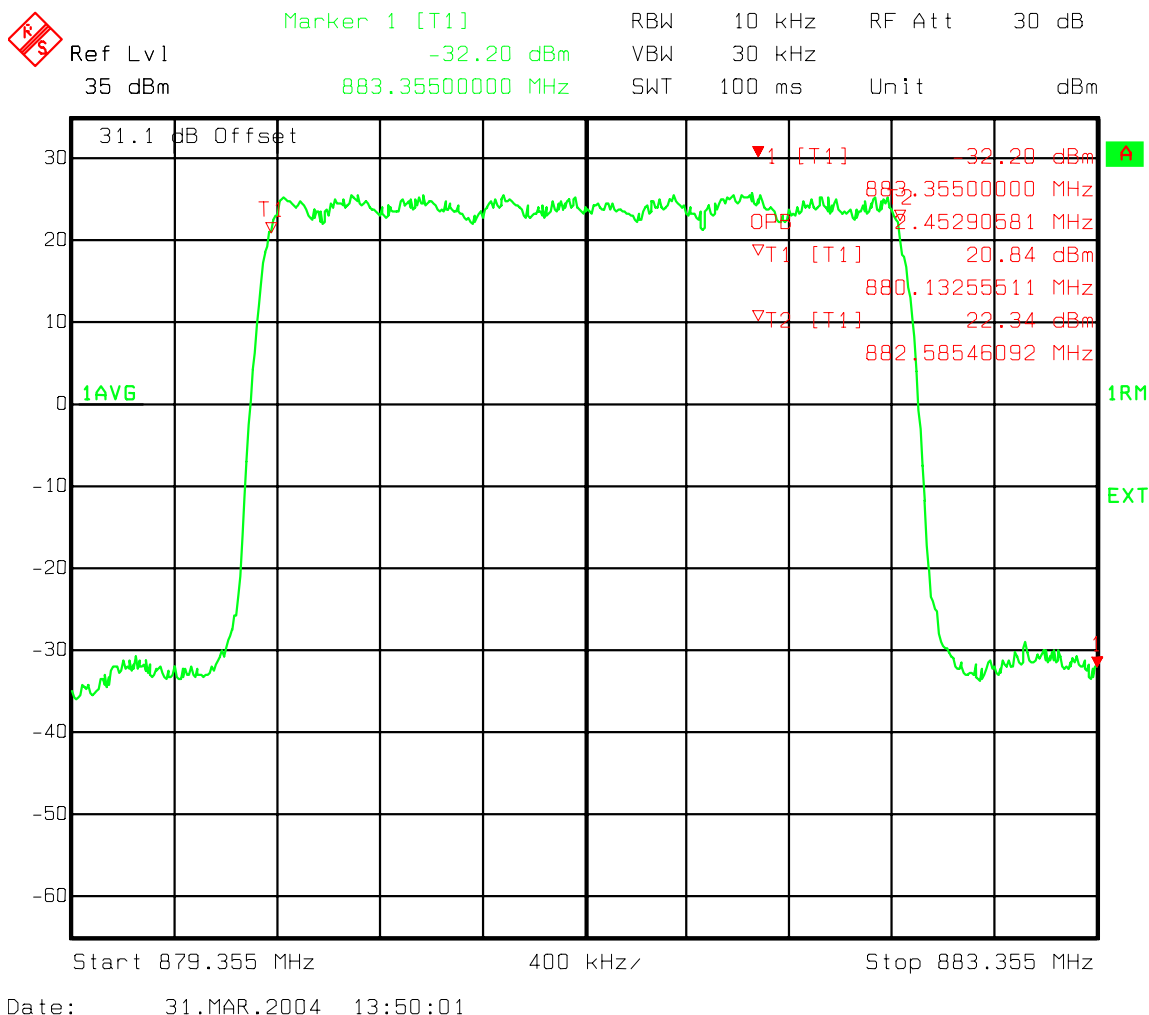

**Figure 27 : One Carrier - A'' and A Band IS95 Spurious emissions 9000-10000 MHz**

## 6 Appendix B - Two Carriers IS-95 Spurious Emission

### Two Carriers 358, 399 and 601, 642 Spurious Emissions at the 800 MHz MFRM1 (Maple) Ant. Port band B IS95

#### Occupied Bandwidth Ch 358, 399 Band B



**Figure 28 : Two Carriers - Occupied Bandwidth Ch 358, 399 Band B**

**Two Carriers 358, 399 and 601, 642 Spurious Emissions at the 800 MHz MFRM1  
(Maple) Ant. Port band B IS95**

**B Band Ch 358, 399 IS95 Adjacent 1 MHz Lower emissions 879-880 MHz**

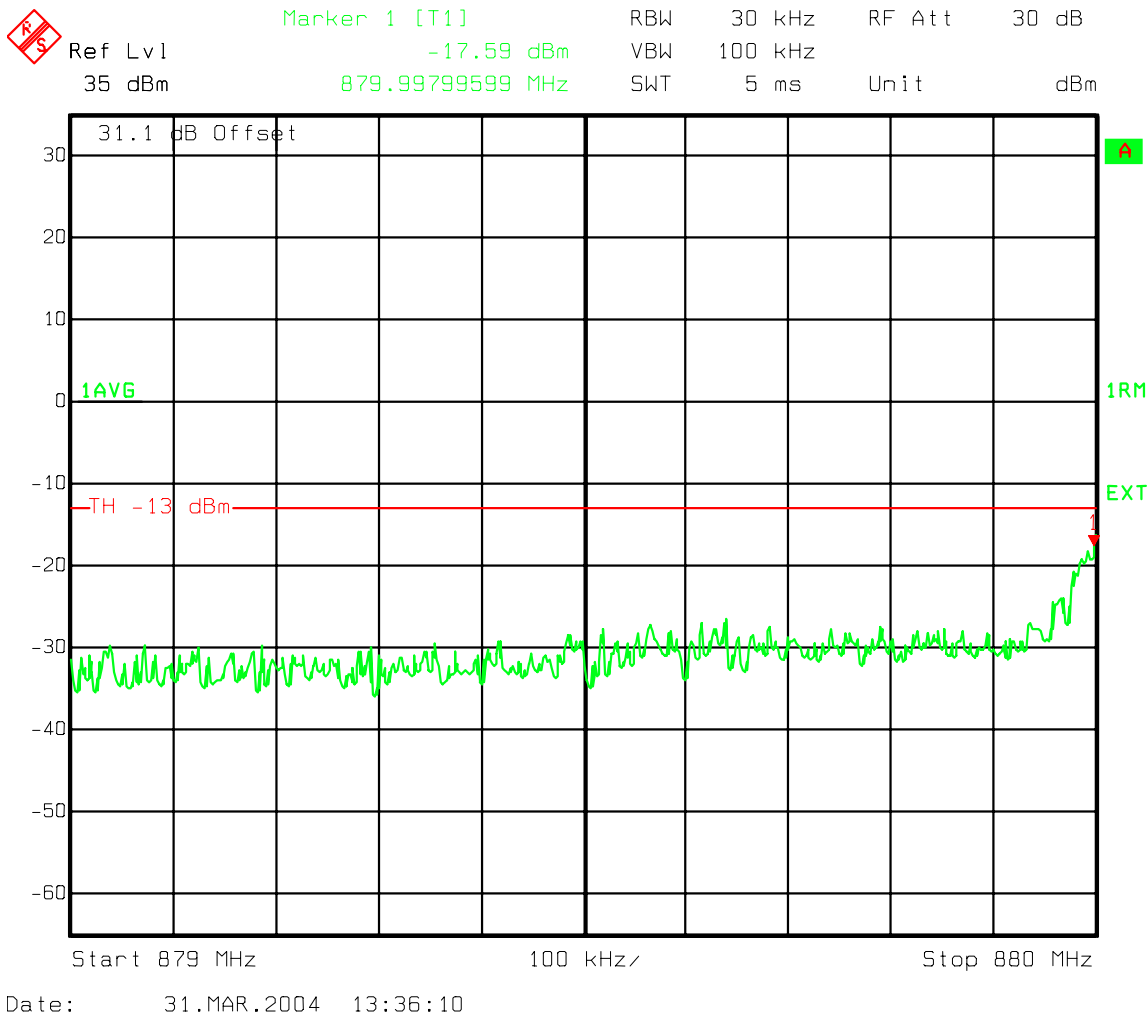

**Figure 29 : Two Carriers - B Band Ch358, 399 IS95 Adjacent 1 MHz Lower emissions 879-880 MHz**

**Two Carriers 358, 399 and 601, 642 Spurious Emissions at the 800 MHz MFRM1  
 (Maple) Ant. Port band B IS95**

**Ch358, 399 IS95 Lower B Band Adjacent to outside edge 25kHz band Channel  
 Power**

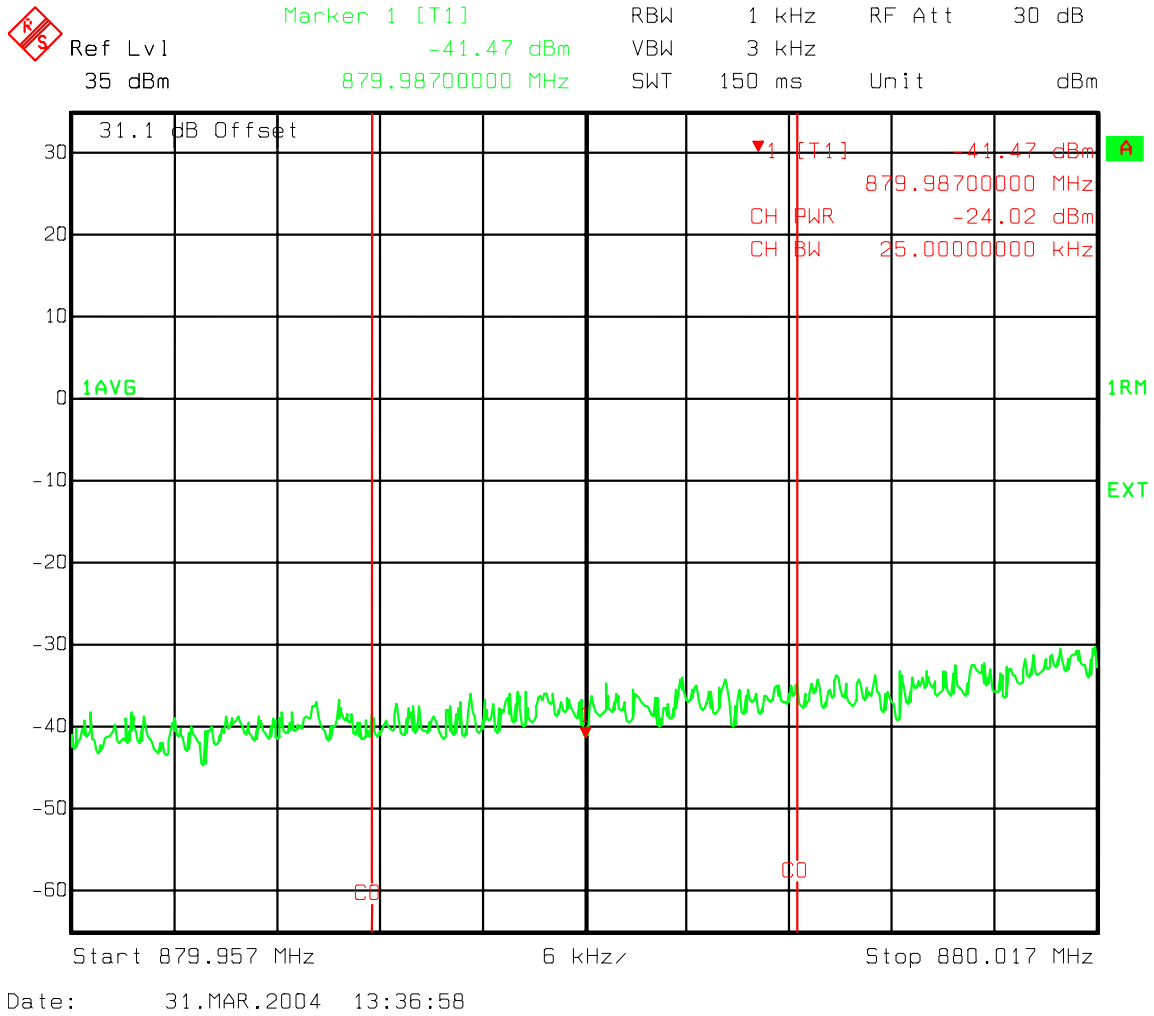
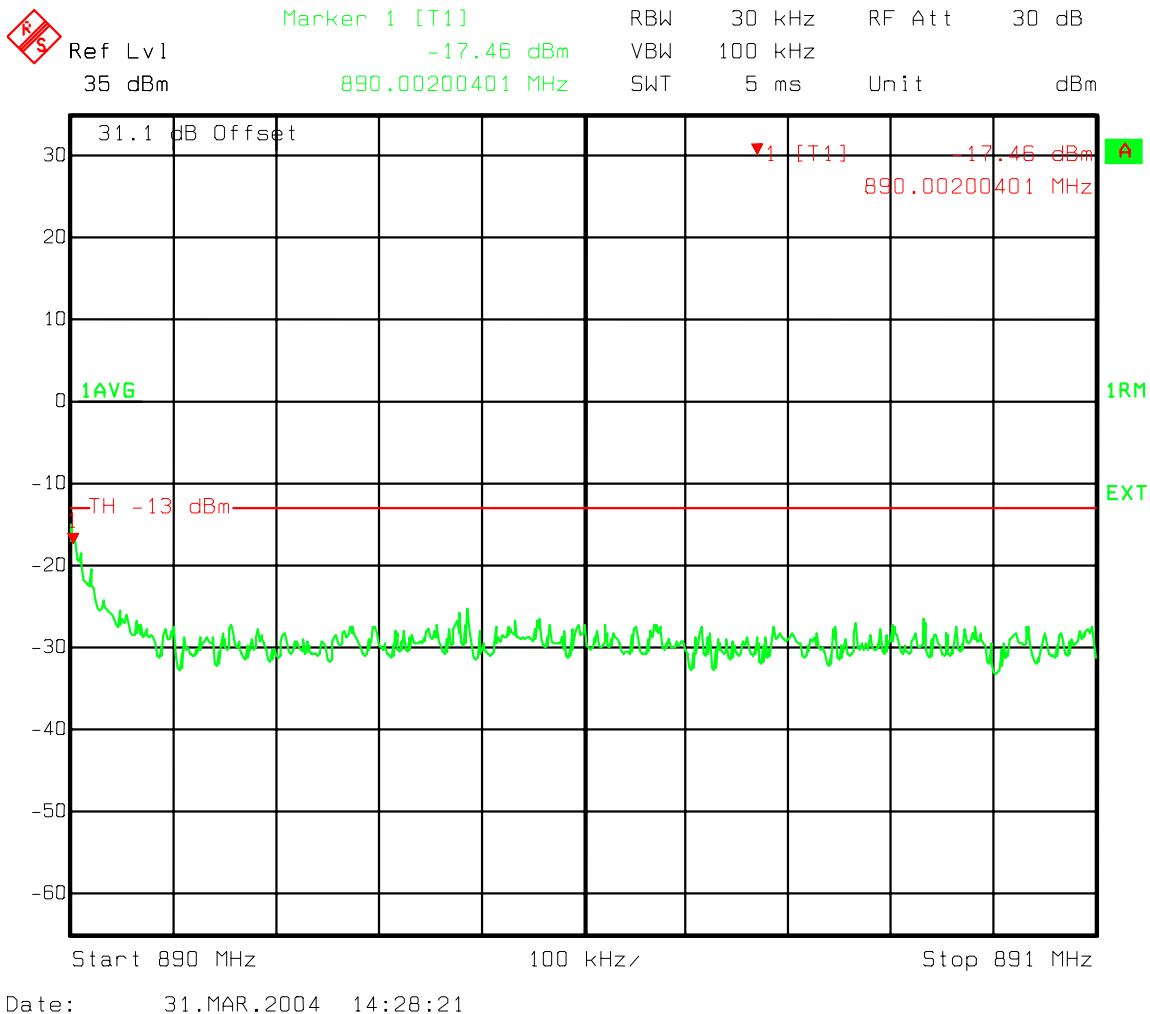

**Figure 30 : Two Carriers - Ch 358, 399 IS95 Lower B Band Adjacent to outside edge 25kHz  
 band Channel Power**



**Two Carriers 358, 399 and 601, 642 Spurious Emissions at the 800 MHz MFRM1  
(Maple) Ant. Port band B IS95**

**Ch 601, 642 Upper a Band adjacent 1 MHz band emissions 890-891 MHz**



**Figure 31 : Two Carriers - Ch 601, 642 Upper B Band adjacent 1 MHz band emissions 890-891 MHz**

**Two Carriers 358, 399 and 601, 642 Spurious Emissions at the 800 MHz MFRM1  
 (Maple) Ant. Port band B IS95**

**Ch 601, 642 Upper B Band adjacent to outside edge 25.0 kHz band Channel power**

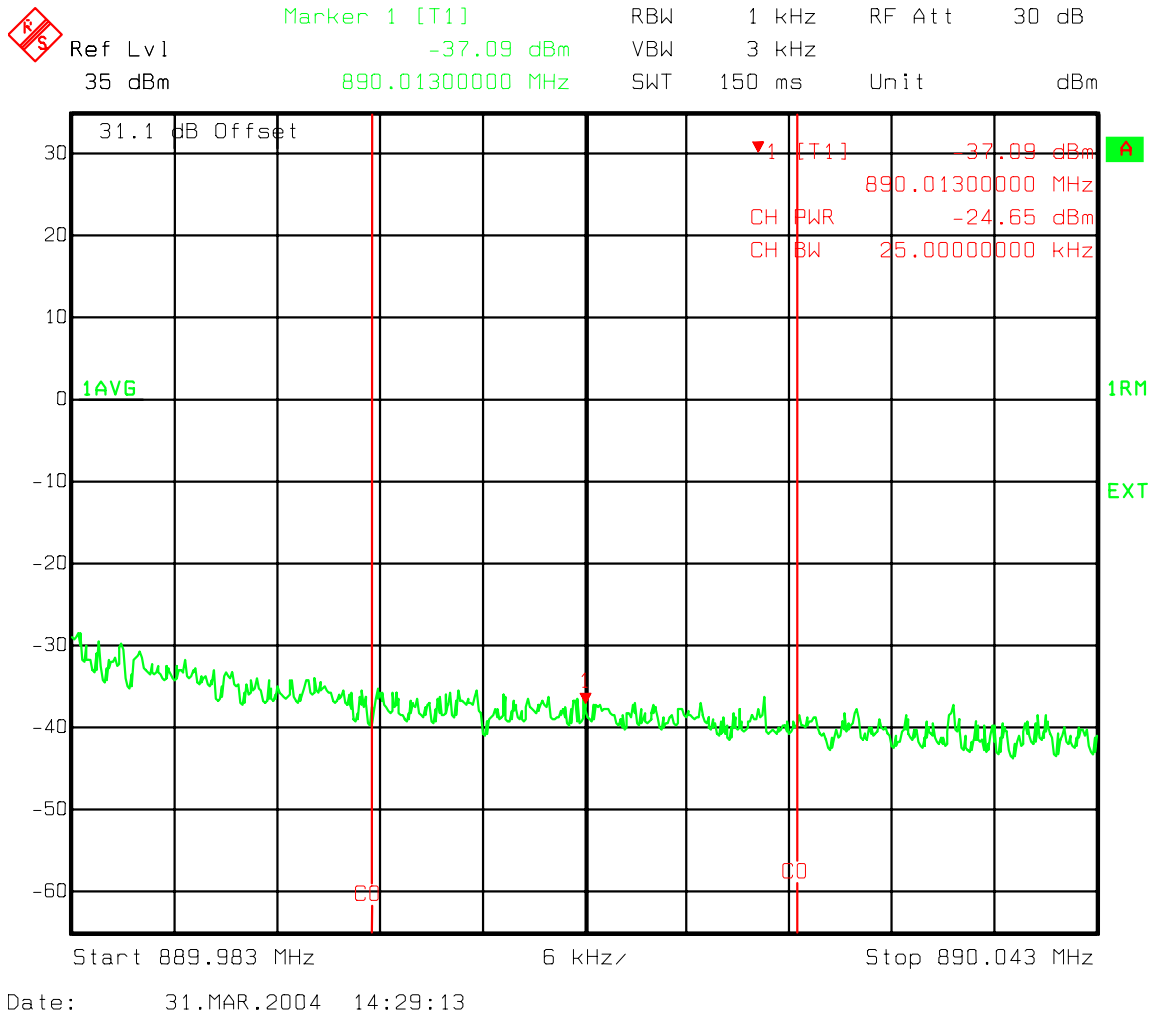

**Figure 32 : Two Carriers - Ch 601, 642 Upper B Band adjacent to outside edge 25.0 kHz  
 band Channel power**

**Two Carriers 358, 399 and 601, 642 Spurious Emissions at the 800 MHz MFRM1 (Maple) Ant. Port band B IS95**

**Industry Canada Lower 750 kHz offset 30 kHz Chan Power Ch 358, 399**

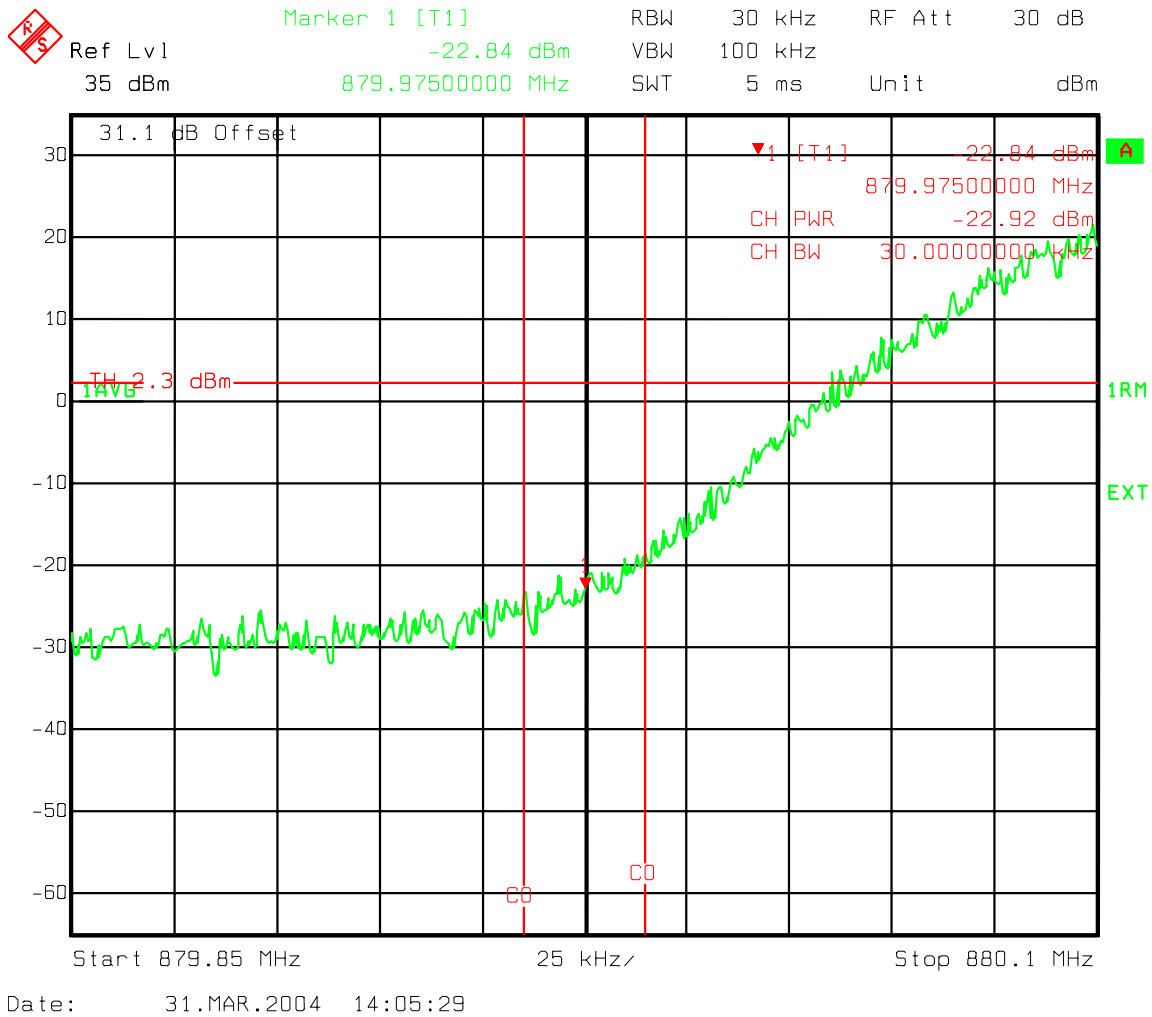

**Figure 33 : Two Carriers - Industry Canada Lower 750 kHz offset 30 kHz Chan Power Ch 358, 399**

**Two Carriers 358, 399 and 601, 642 Spurious Emissions at the 800 MHz MFRM1  
 (Maple) Ant. Port band B IS95**

**Industry Canada Upper 750 kHz offset 30 kHz Chan Power Ch 358, 399**

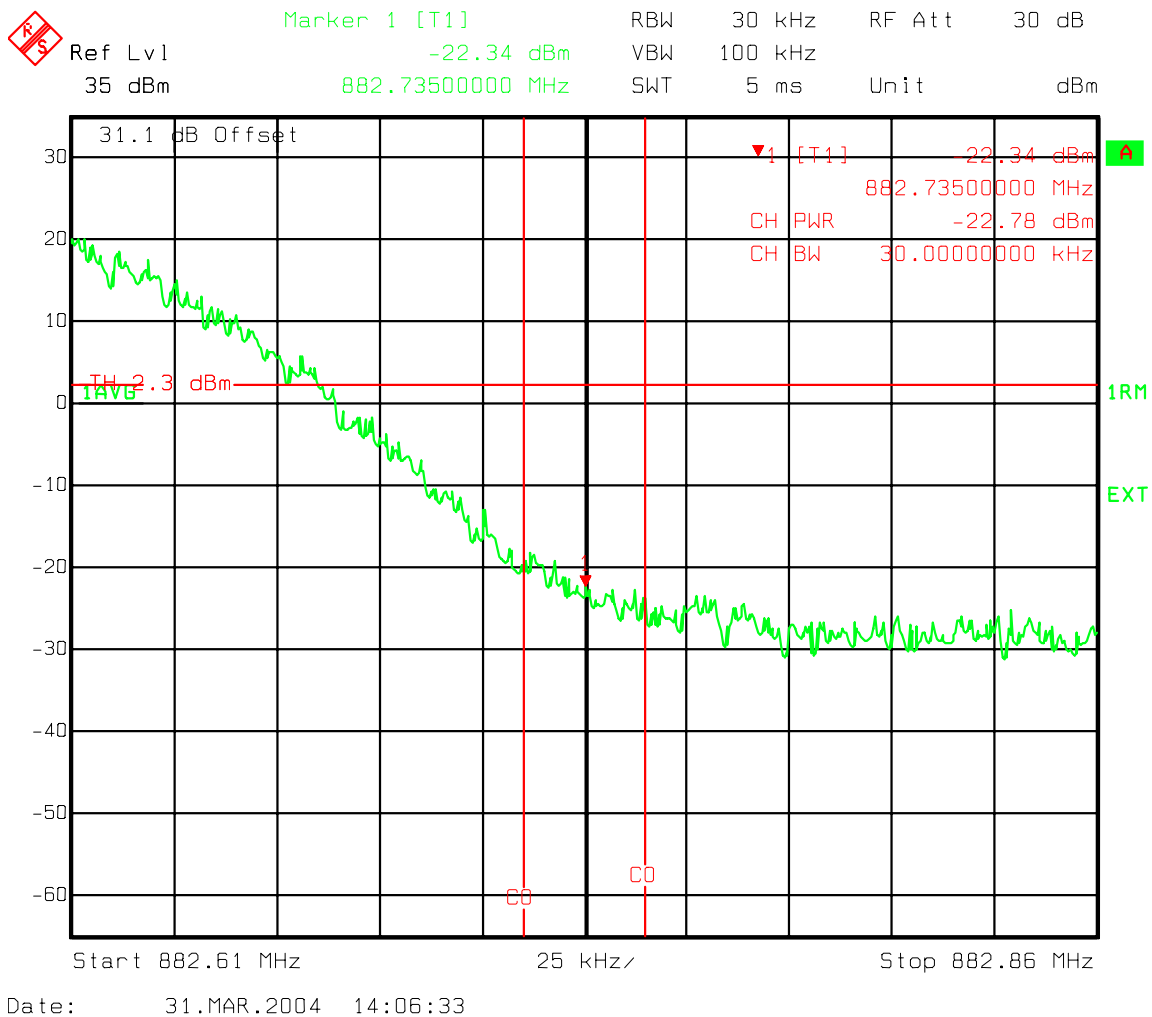

**Figure 34 : Two Carriers - Industry Canada Upper 750 kHz offset 30 kHz Chan Power Ch 358, 399**

**Two Carriers 358, 399 and 601, 642 Spurious Emissions at the 800 MHz MFRM1 (Maple) Ant. Port band B IS95**

**Industry Canada 1.98 MHz offset Lower 30 kHz Chan Power Ch 358, 399**

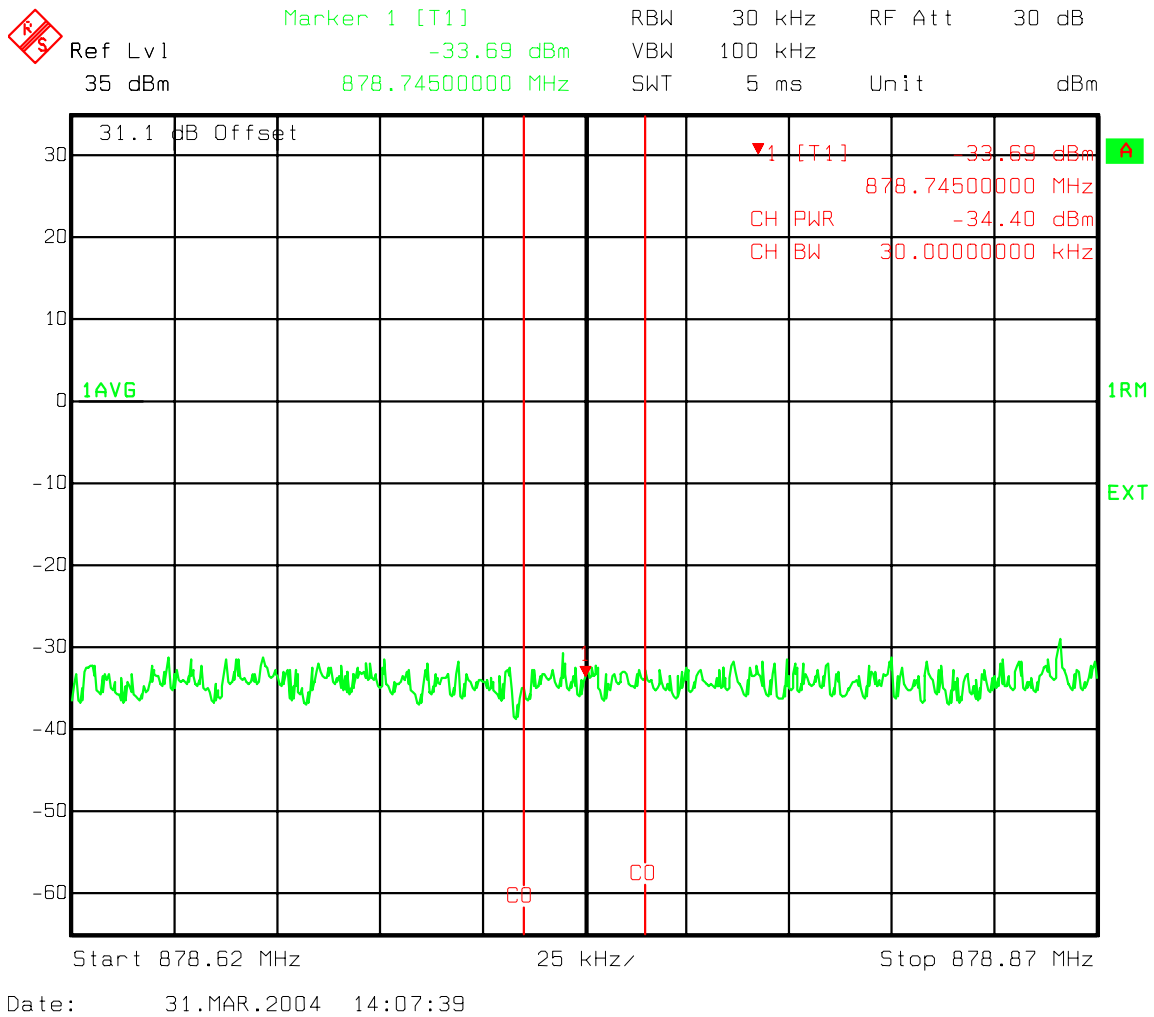

**Figure 35 : Two Carriers - Industry Canada 1.98 MHz offset Lower 30 kHz Chan Power Ch 358, 399**

**Two Carriers 358, 399 and 601, 642 Spurious Emissions at the 800 MHz MFRM1 (Maple) Ant. Port band B IS95**

**Industry Canada 1.98 MHz offset Upper 30 kHz Chan Power Ch 358, 399**

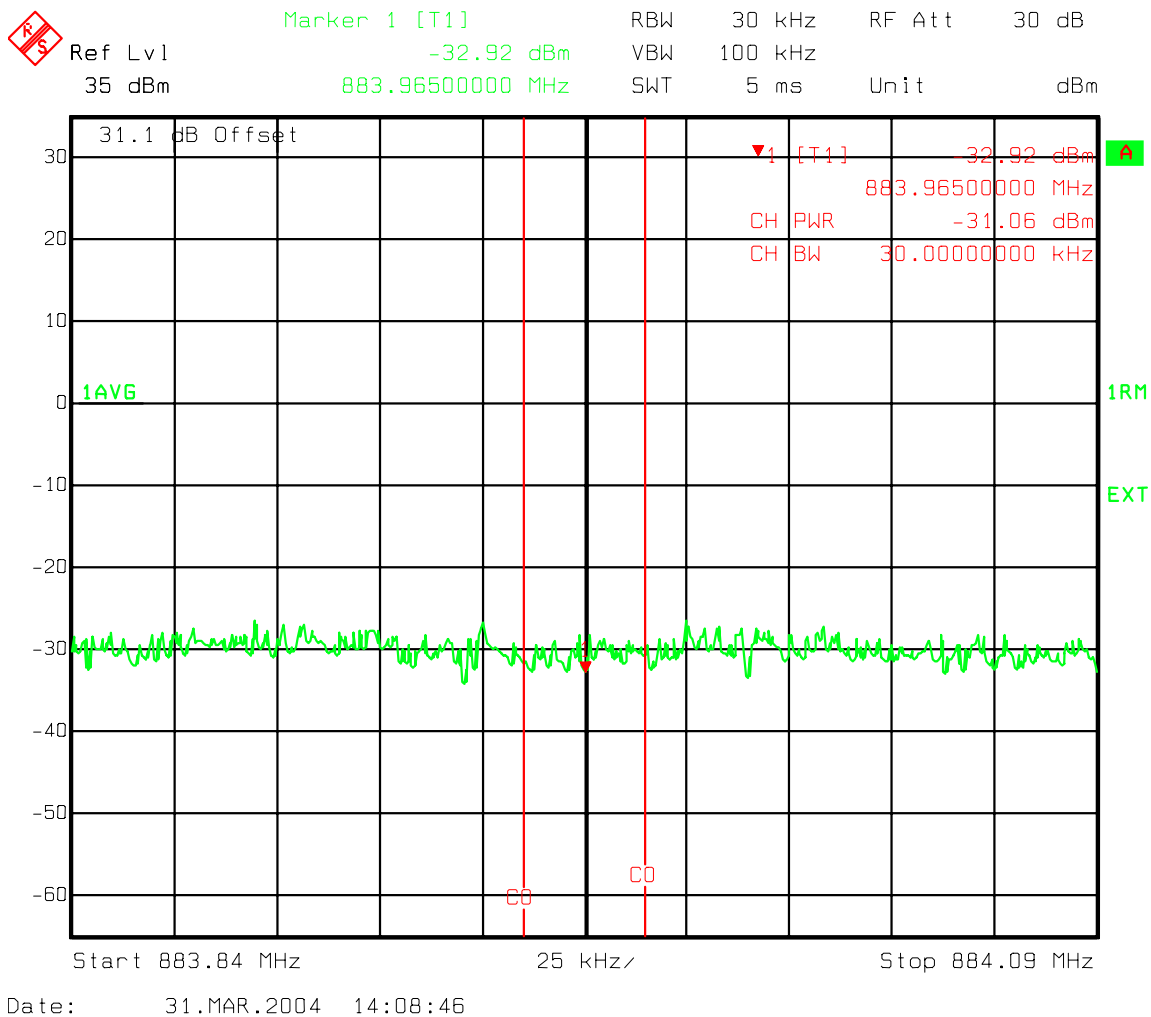

**Figure 36 : Two Carriers - Industry Canada 1.98 MHz offset Upper 30 kHz Chan Power Ch. 358, 399**

**Two Carriers 358, 399 and 601, 642 Spurious Emissions at the 800 MHz MFRM1 (Maple) Ant. Port band B IS95**

**B Band IS95 Spurious emissions 10kHz-400 MHz**

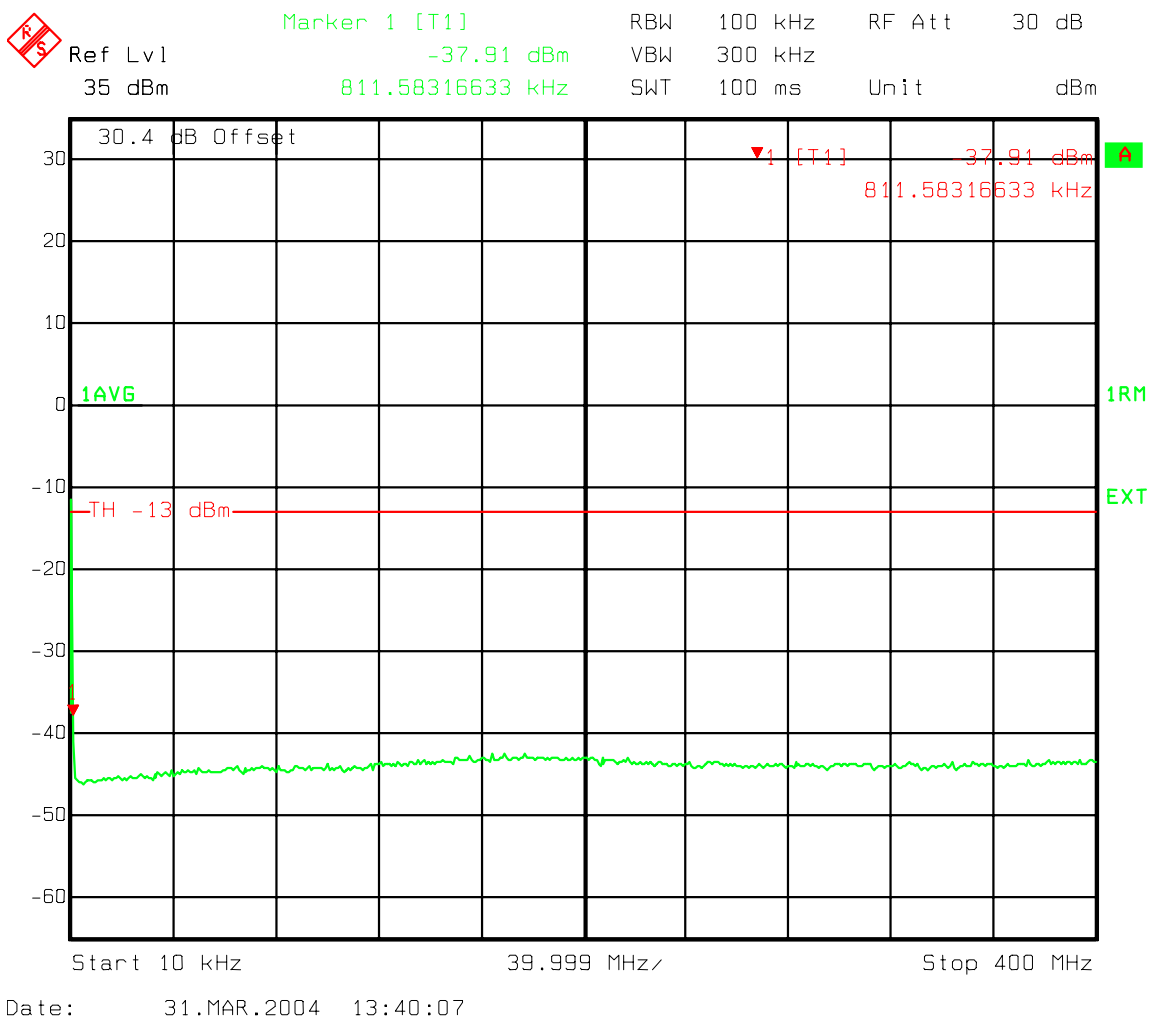

**Figure 37 : Two Carriers - B Band IS95 Spurious emissions 10kHz-400 MHz**

**Two Carriers 358, 399 and 601, 642 Spurious Emissions at the 800 MHz MFRM1 (Maple) Ant. Port band B IS95**

**B Band IS95 Spurious emissions 400 MHz to Lower 1 MHz Band Edge**

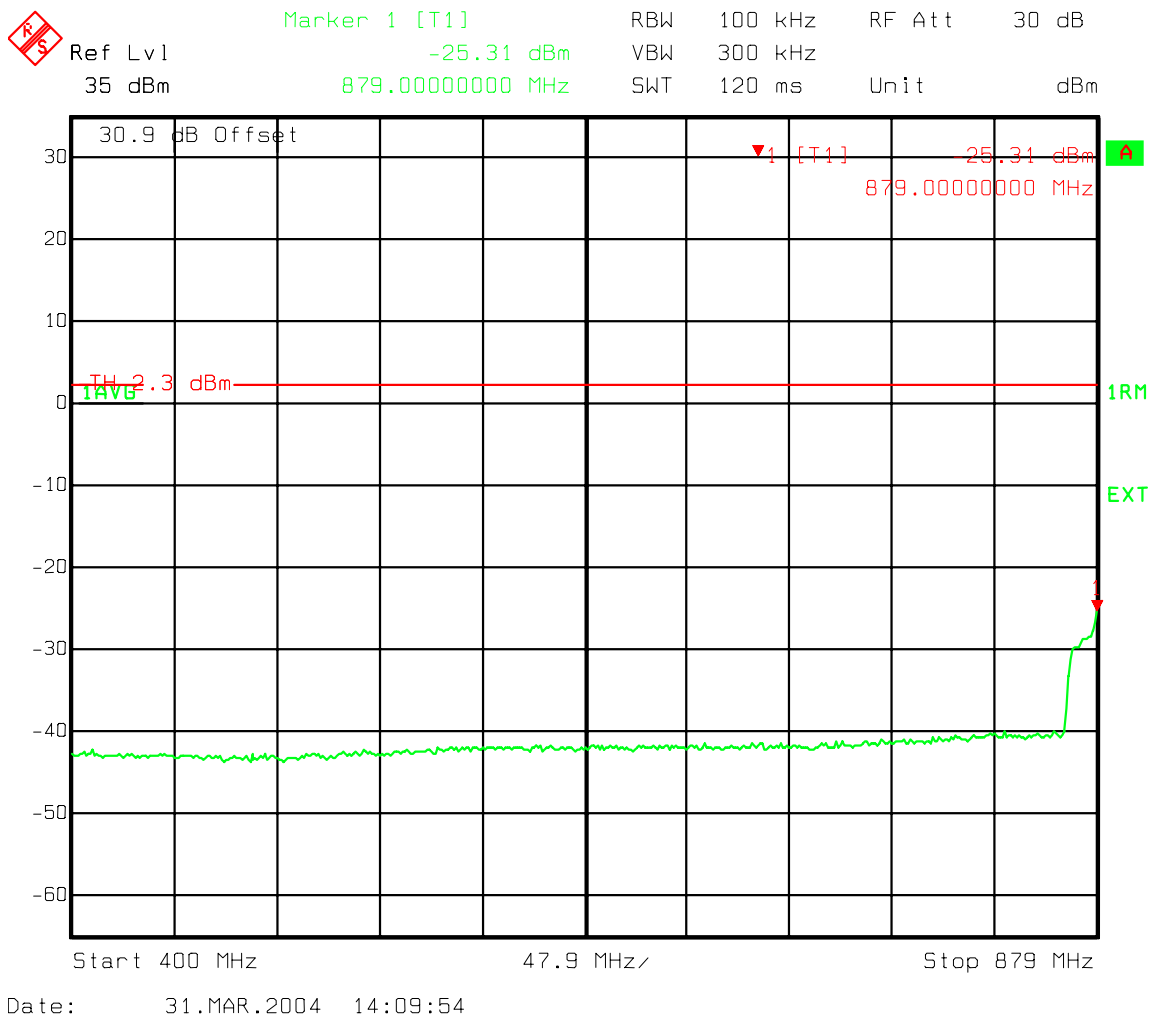
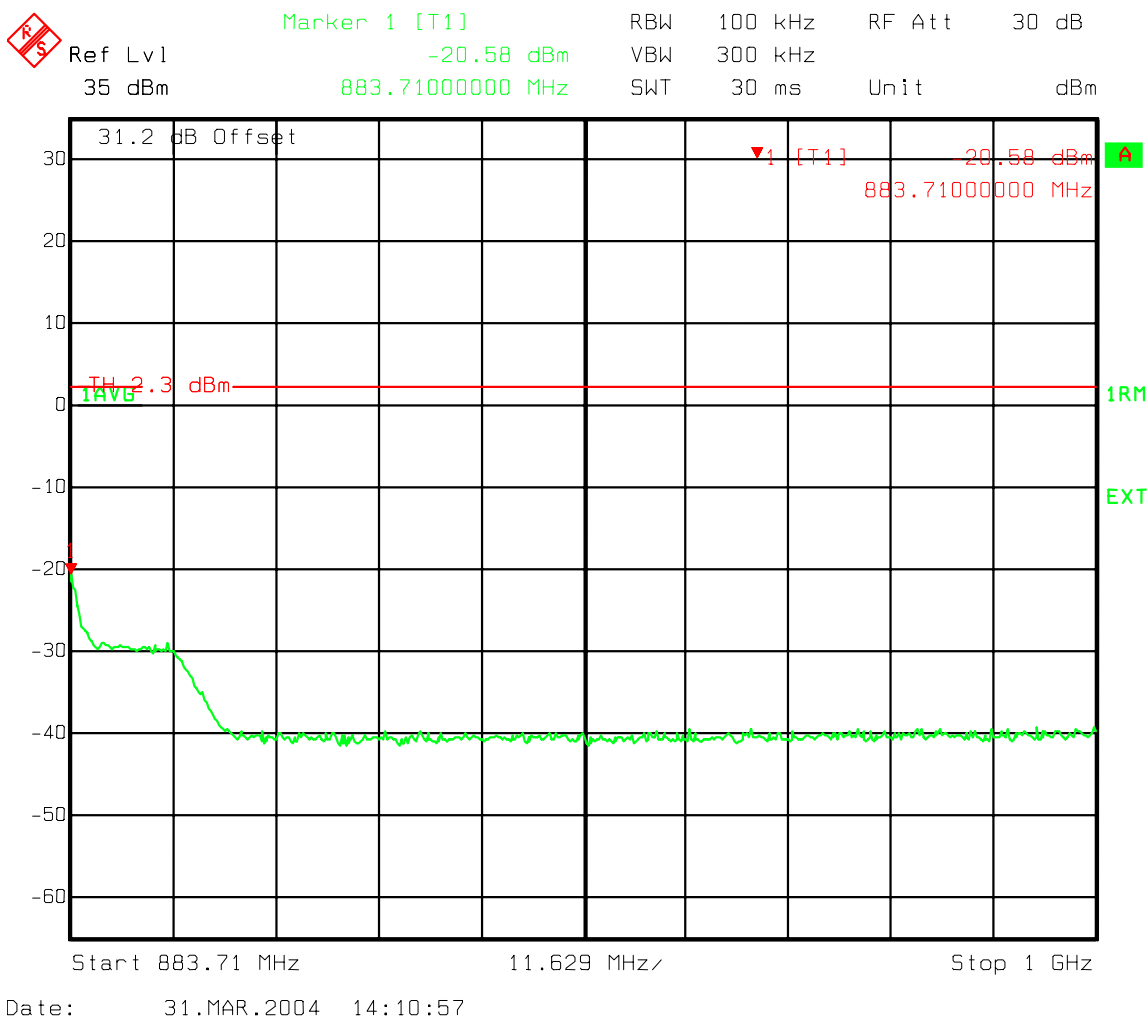

**Figure 38 : Two Carriers - B Band IS95 Spurious emissions 400 MHz to Lower 1 MHz Band Edge**



**Two Carriers 358, 399 and 601, 642 Spurious Emissions at the 800 MHz MFRM1 (Maple) Ant. Port band B IS95**

**B Band IS95 Spurious emissions Upper 1 MHz Band Edge to 1 GHz**



**Figure 39 : Two Carriers - B Band IS95 Spurious emissions Upper 1 MHz Band Edge to 1 GHz**

**Two Carriers 358, 399 and 601, 642 Spurious Emissions at the 800 MHz MFRM1  
 (Maple) Ant. Port band B IS95**

**B Band IS95 Spurious emissions 400-1000 MHz**

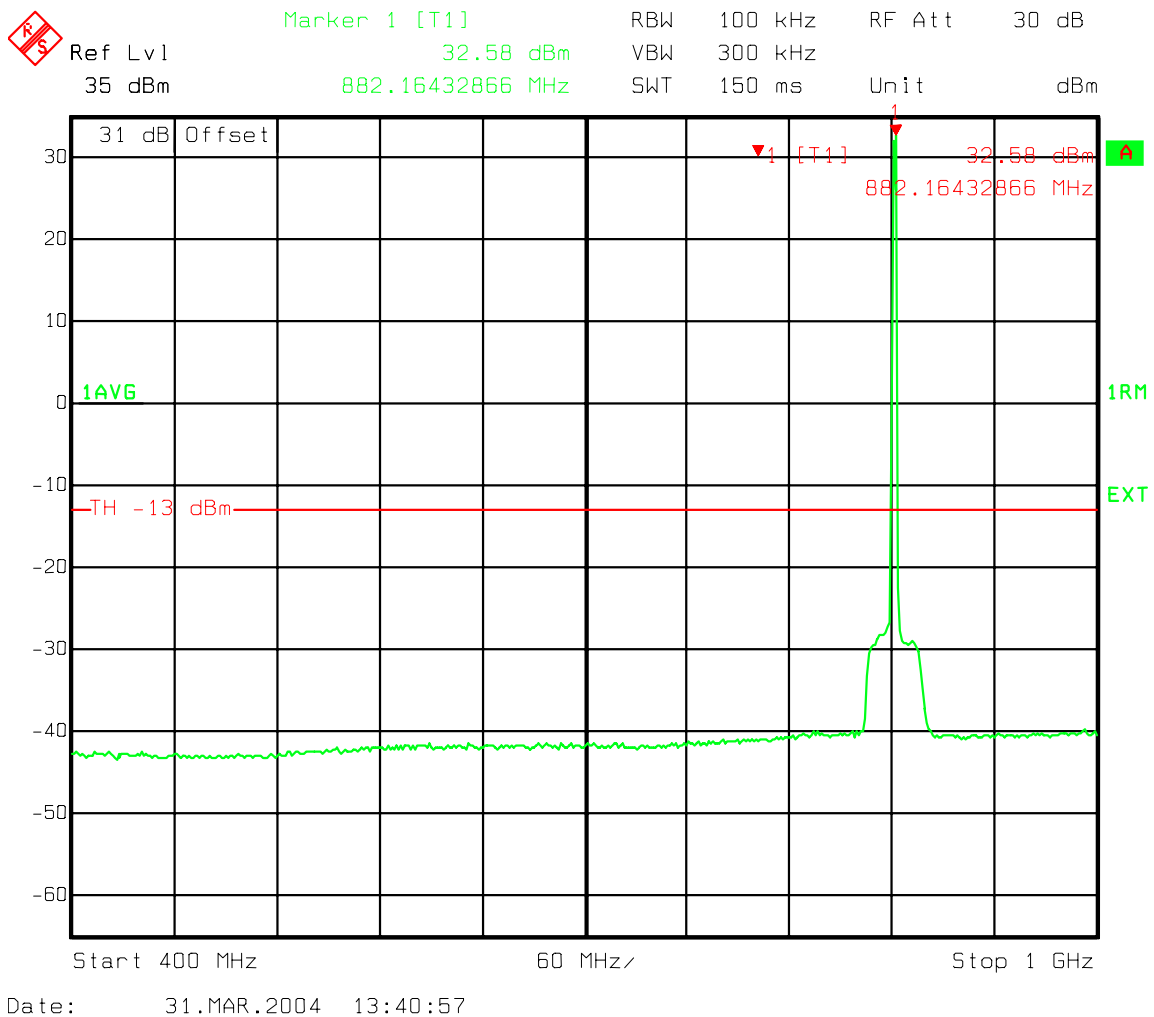

**Figure 40 : Two Carriers - B Band IS95 Spurious emissions 400-1000 MHz**

### Two Carriers 358, 399 and 601, 642 Spurious Emissions at the 800 MHz MFRM1 (Maple) Ant. Port band B IS95

#### B Band IS95 Spurious emissions 1000-2000 MHz

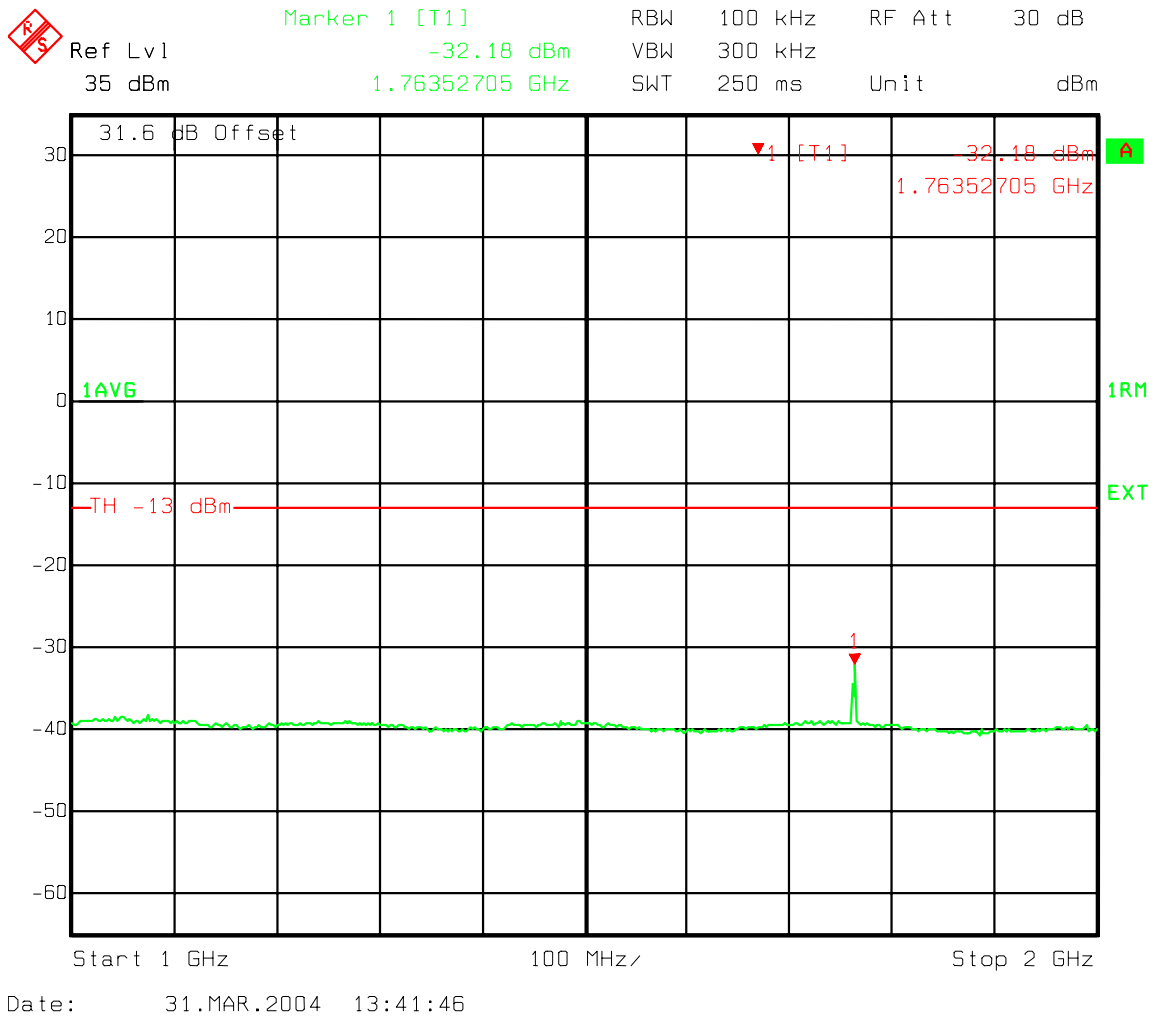
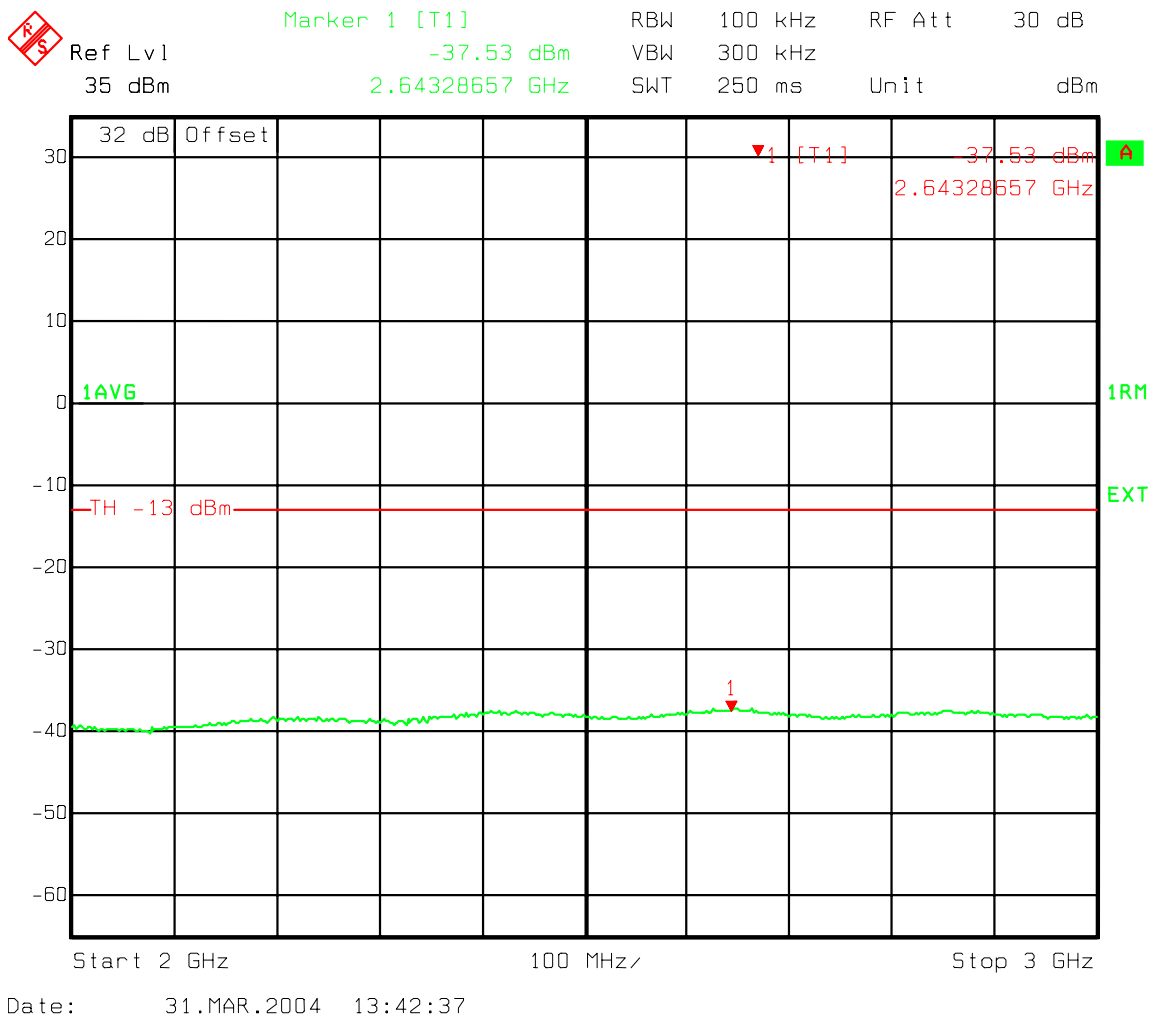

Figure 41 : Two Carriers - B Band IS95 Spurious emissions 1000-2000 MHz

**Two Carriers 358, 399 and 601, 642 Spurious Emissions at the 800 MHz MFRM1 (Maple) Ant. Port band B IS95**

**B Band IS95 Spurious emissions 2000-3000 MHz**



**Figure 42 : Two Carriers - B Band IS95 Spurious emissions 2000-3000 MHz**

**Two Carriers 358, 399 and 601, 642 Spurious Emissions at the 800 MHz MFRM1 (Maple) Ant. Port band B IS95**

**B Band IS95 Spurious emissions 3000-4000 MHz**

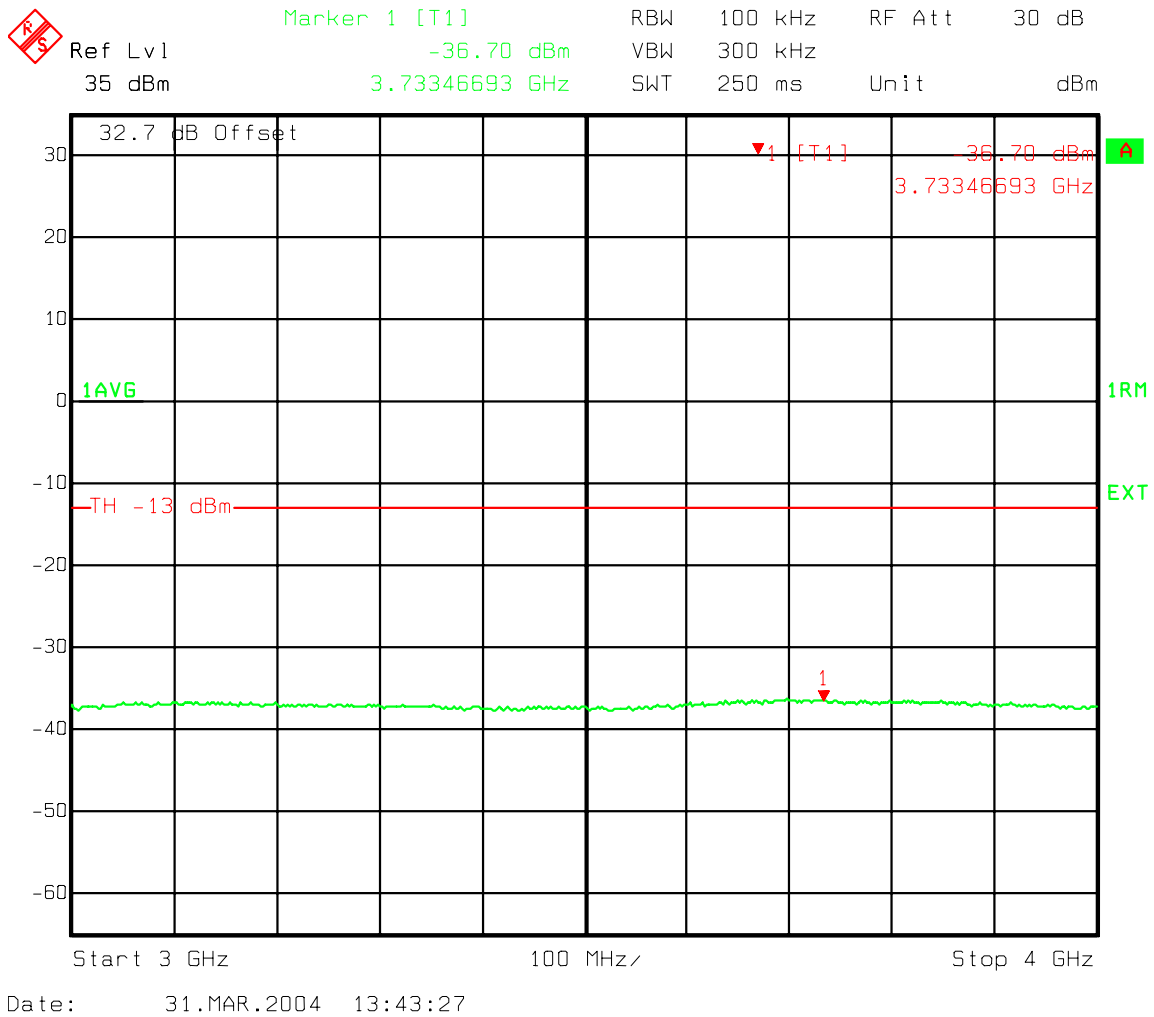

**Figure 43 : Two Carriers - B Band IS95 Spurious emissions 3000-4000 MHz**

**Two Carriers 358, 399 and 601, 642 Spurious Emissions at the 800 MHz MFRM1 (Maple) Ant. Port band B IS95**

**B Band IS95 Spurious emissions 4000-5000 MHz**

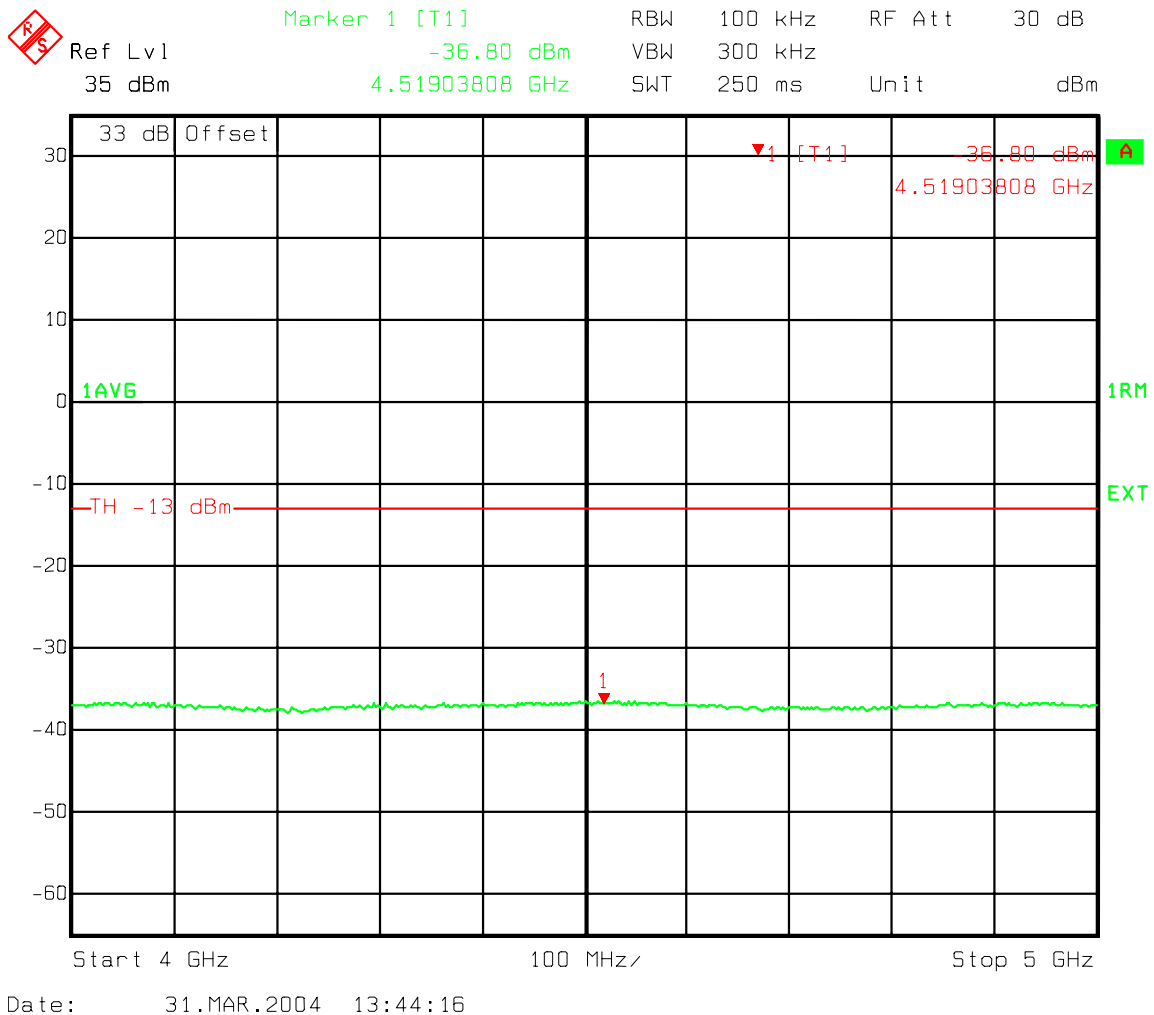
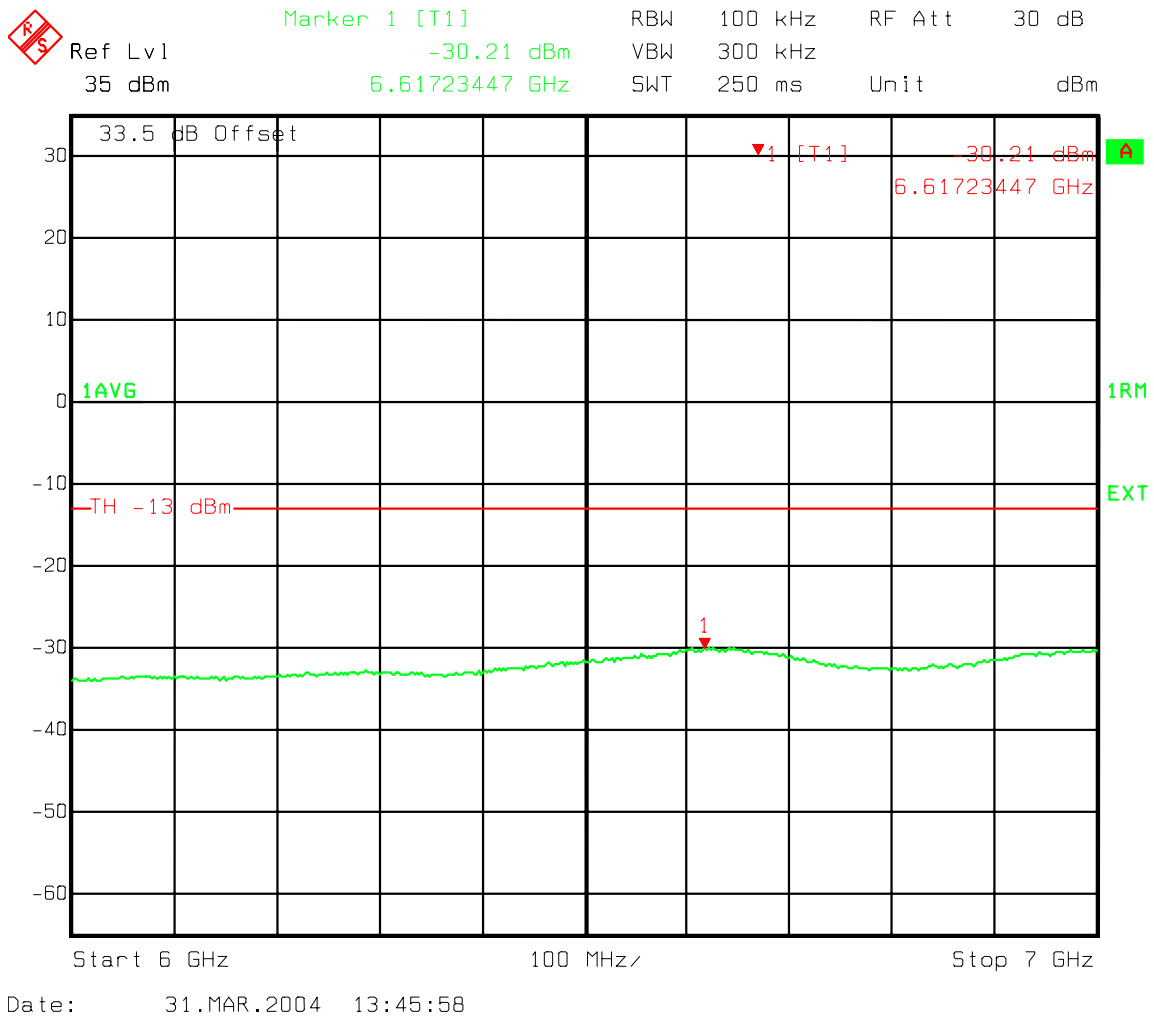

**Figure 44 : Two Carriers - B Band IS95 Spurious emissions 4000-5000 MHz**



**Two Carriers 358, 399 and 601, 642 Spurious Emissions at the 800 MHz MFRM1  
 (Maple) Ant. Port band B IS95**

**B Band IS95 Spurious emissions 6000-7000 MHz**

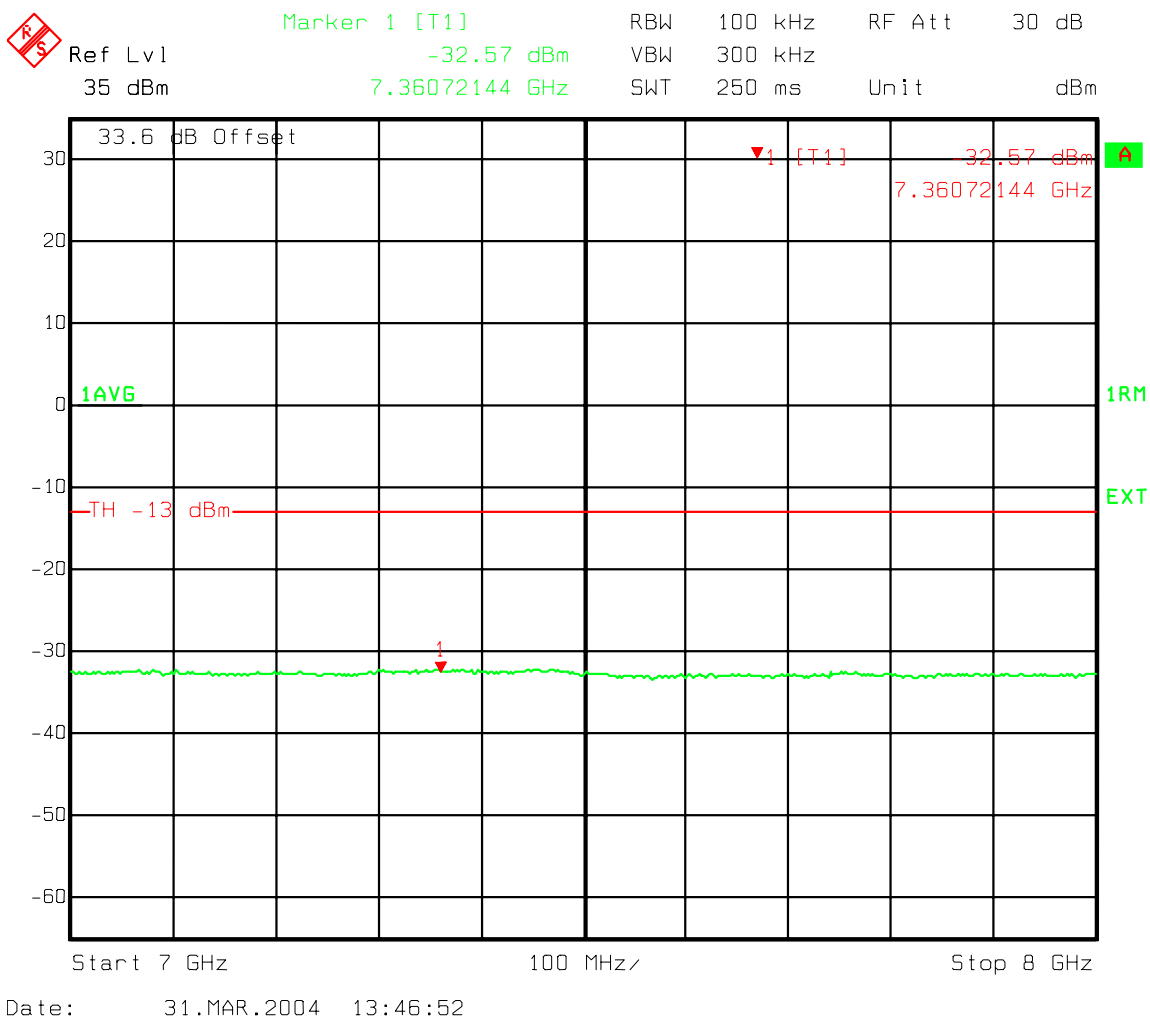

**Figure 46 : Two Carriers - B Band IS95 Spurious emissions 6000-7000 MHz**



**Two Carriers 358, 399 and 601, 642 Spurious Emissions at the 800 MHz MFRM1 (Maple) Ant. Port band B IS95**

**B Band IS95 Spurious emissions 7000-8000 MHz**



**Figure 47 : Two Carriers - B Band IS95 Spurious emissions 7000-8000 MHz**

**Two Carriers 358, 399 and 601, 642 Spurious Emissions at the 800 MHz MFRM1 (Maple) Ant. Port band B IS95**

**B Band IS95 Spurious emissions 8000-9000 MHz**

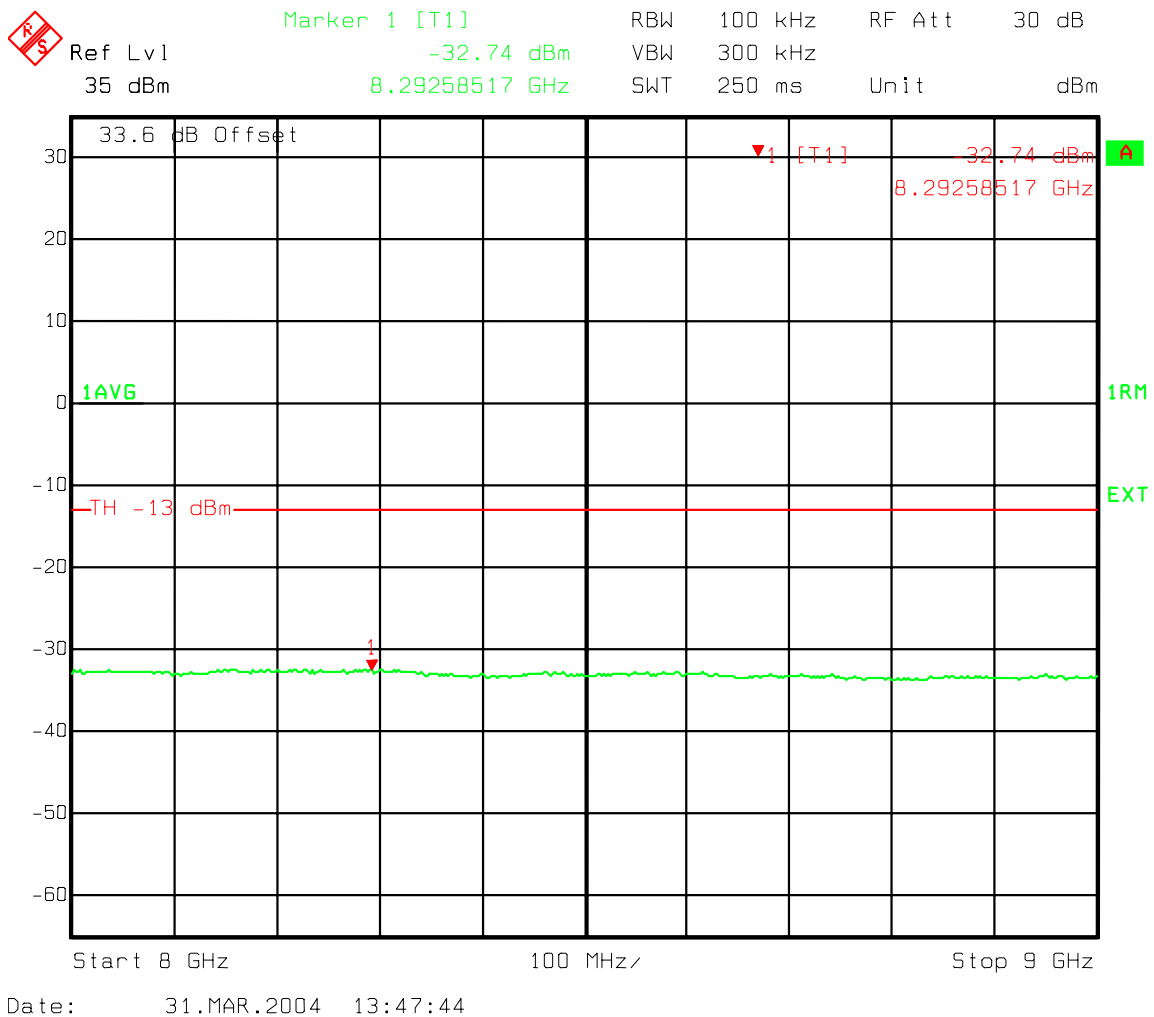

**Figure 48 : Two Carriers - B Band IS95 Spurious emissions 8000-9000 MHz**

**Two Carriers 358, 399 and 601, 642 Spurious Emissions at the 800 MHz MFRM1 (Maple) Ant. Port band B IS95**

**B Band IS95 Spurious emissions 9000-10000 MHz**

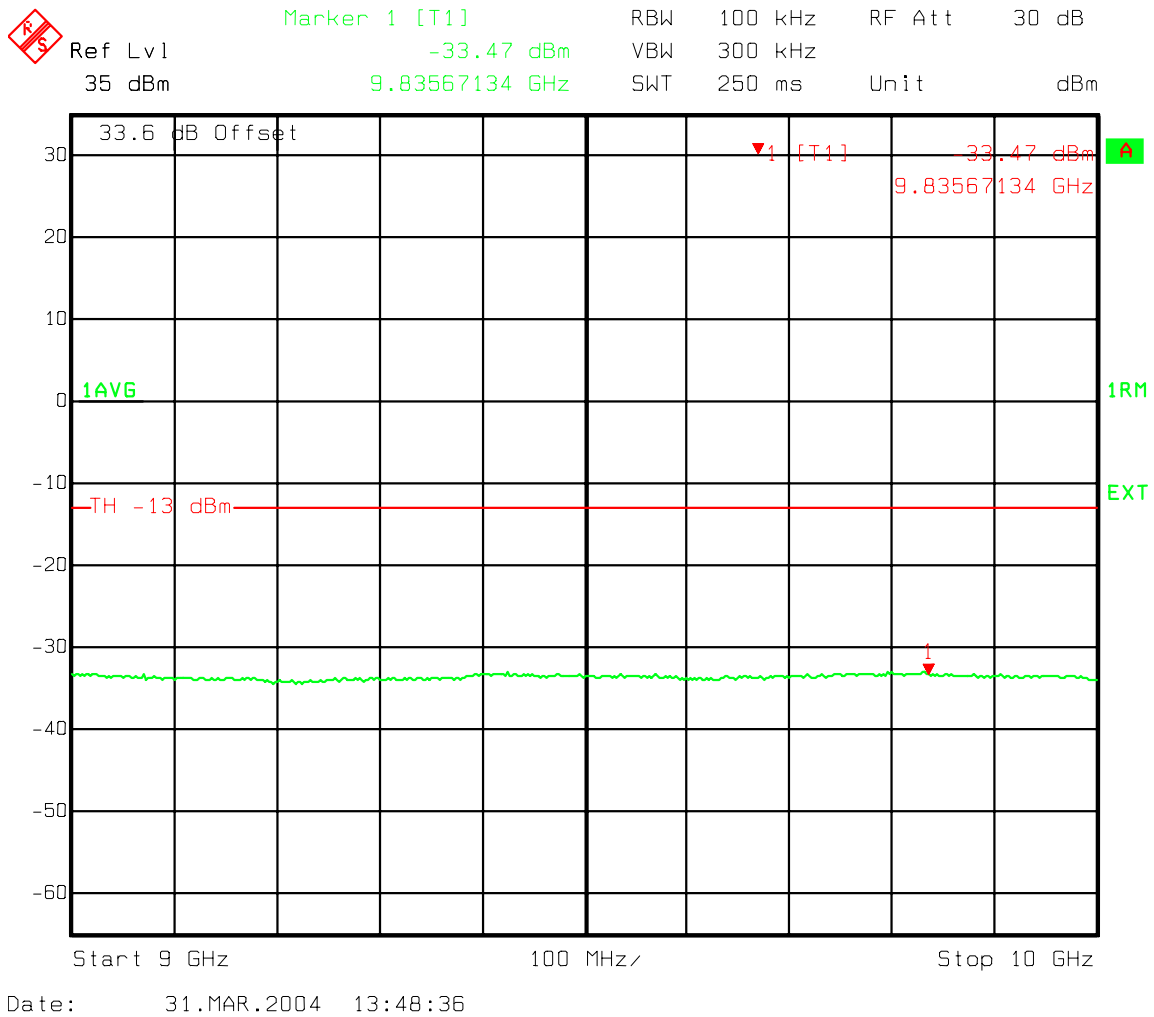

**Figure 49 : Two Carriers - B Band IS95 Spurious emissions 9000-10000 MHz**

## 7 Appendix C - Three Carrier IS-95 Spurious Emission

### Three Carrier Channel 1015, 33, 74 and 226, 267, 308 Spurious Emissions at the 800 MHz MFRM1 (Maple) Ant. Port Band A and A” IS95

#### Occupied Bandwidth Ch 1015, 33, 74 A”

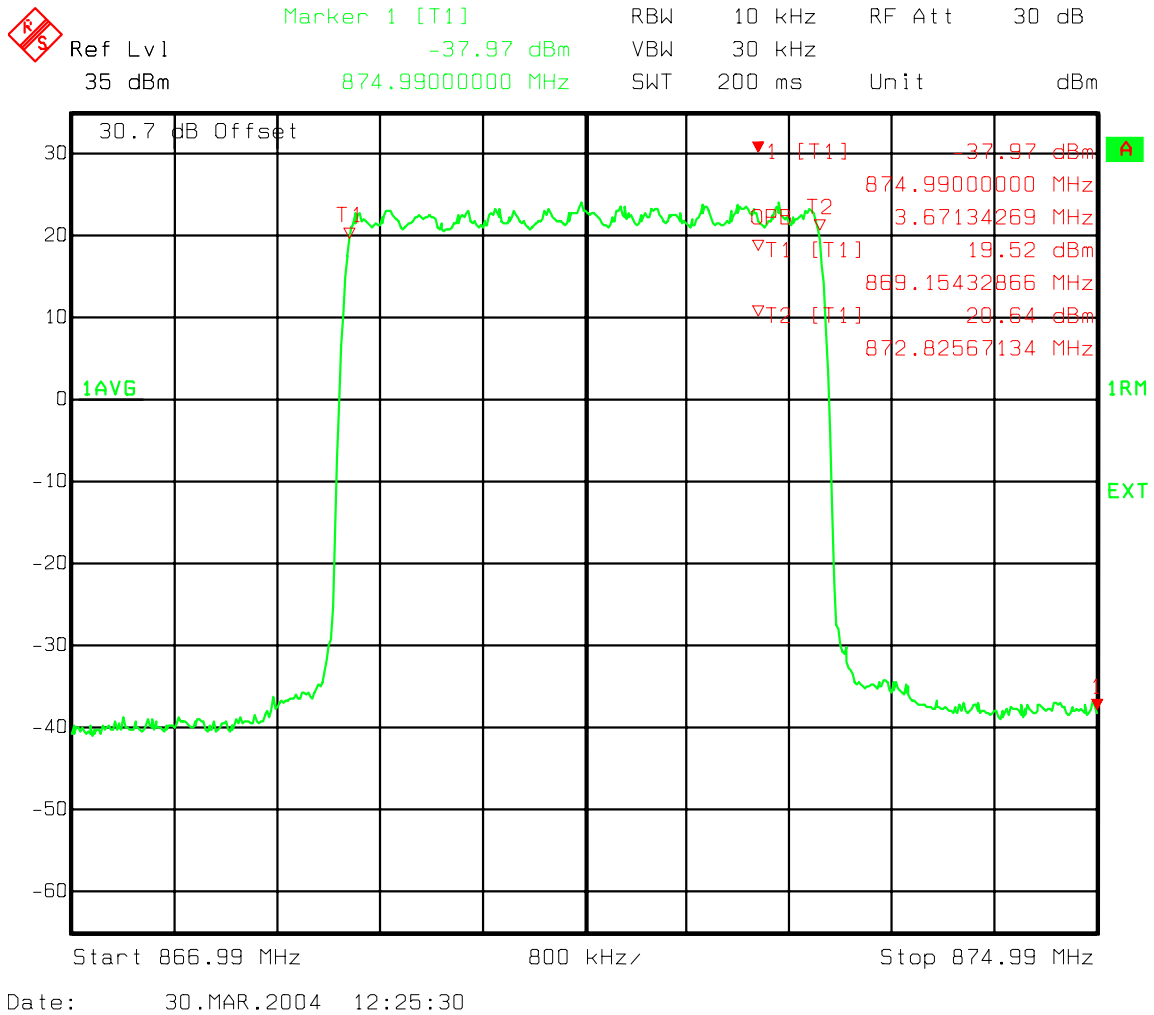
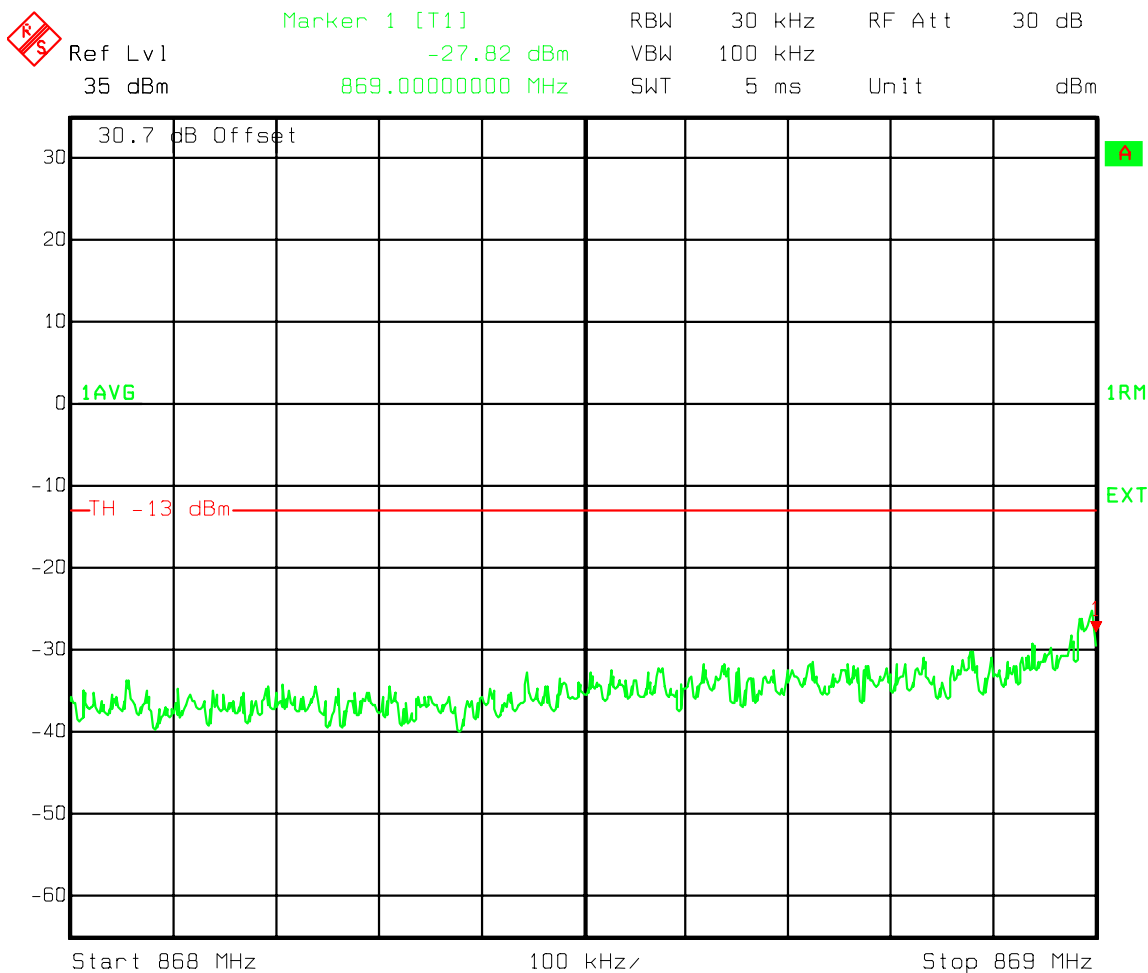

Figure 50 : Three Carriers - Occupied Bandwidth Ch 1015, 33, 74 A”

**Three Carrier Channel 1015, 33, 74 and 226, 267, 308 Spurious Emissions at the 800 MHz MFRM1 (Maple) Ant. Port Band A and A'' IS95**

**A'' Band Ch 1015, 33, 74 IS95 Adjacent 1MHz Lower emissions 868-869MHz**



Date: 30.MAR.2004 12:15:12

**Figure 51 : Three Carriers - A'' Band Ch 1015, 33, 74 IS95 Adjacent 1MHz Lower emissions 868-869MHz**

**Three Carrier Channel 1015, 33, 74 and 226, 267, 308 Spurious Emissions at the 800 MHz MFRM1 (Maple) Ant. Port Band A and A" IS95**

**Ch 1015, 33, 74 IS95 Lower A" Band Adjacent to outside edge 37.5kHz band Channel Power**

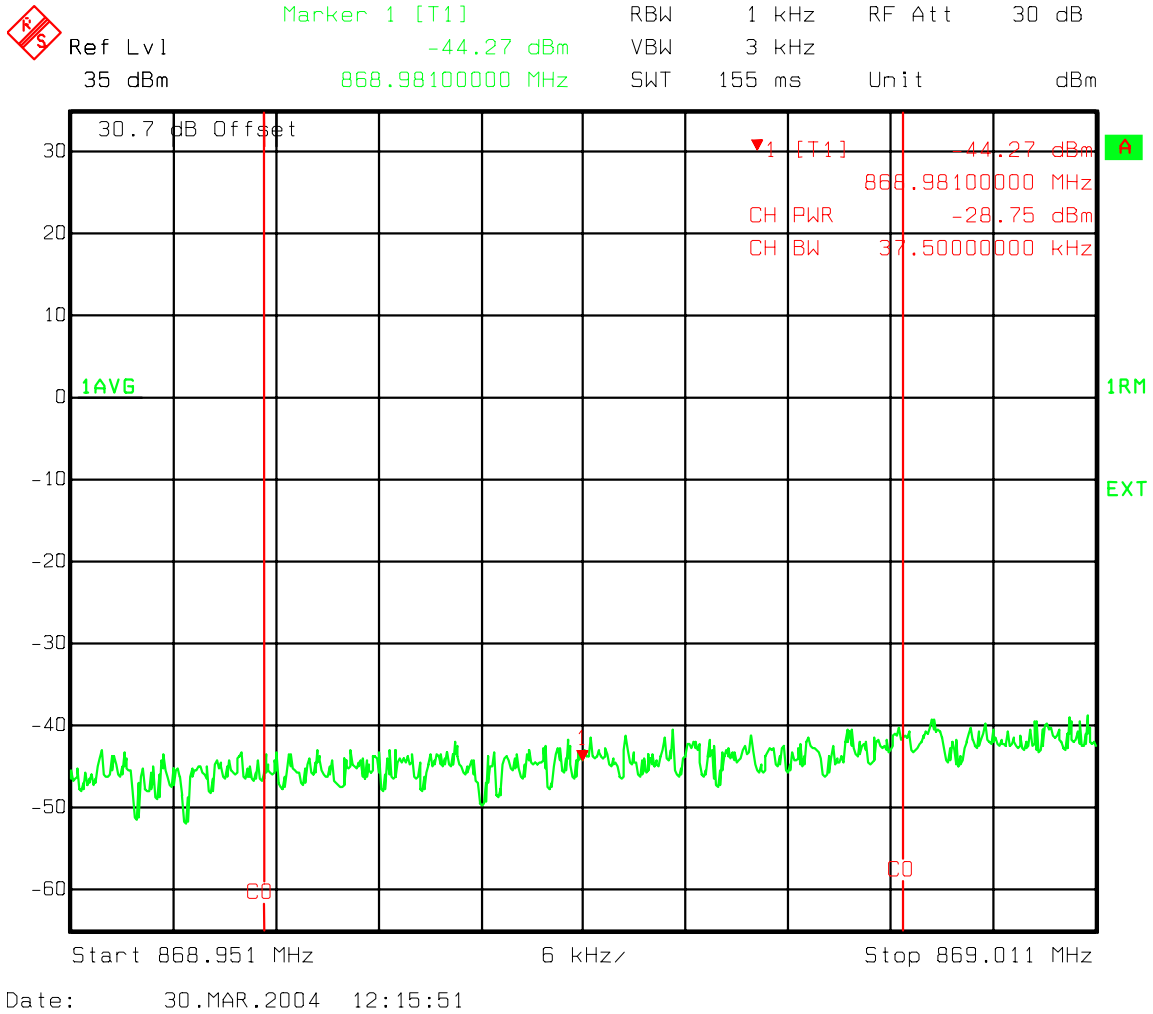

**Figure 52 : Three Carriers - Ch 1015, 33, 74 IS95 Lower A" Band Adjacent to outside edge 37.5kHz band Channel Power**

**Three Carrier Channel 1015, 33, 74 and 226, 267, 308 Spurious Emissions at the 800 MHz MFRM1 (Maple) Ant. Port Band A and A" IS95**

**Ch 226, 267, 308 Upper a Band adjacent 1 MHz band emissions 880-881 MHz**

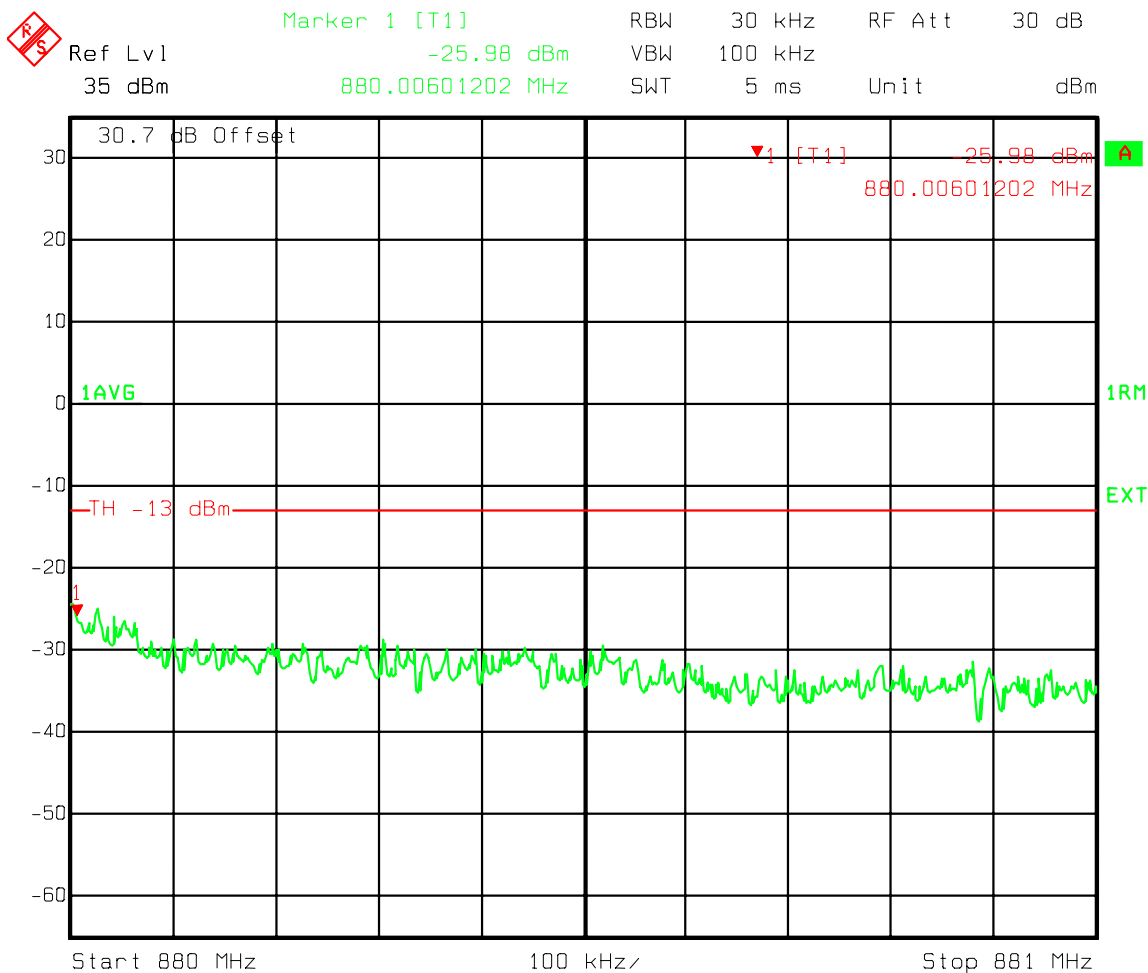

Date: 30.MAR.2004 11:39:35

**Figure 53 : Three Carriers - Ch 226, 267, 308 Upper a Band adjacent 1 MHz band emissions 880-881 MHz**

**Three Carrier Channel 1015, 33, 74 and 226, 267, 308 Spurious Emissions at the 800 MHz MFRM1 (Maple) Ant. Port Band A and A" IS95**

**Ch 226, 267, 308 Upper A Band adjacent to outside edge 37.5 kHz band Channel power**

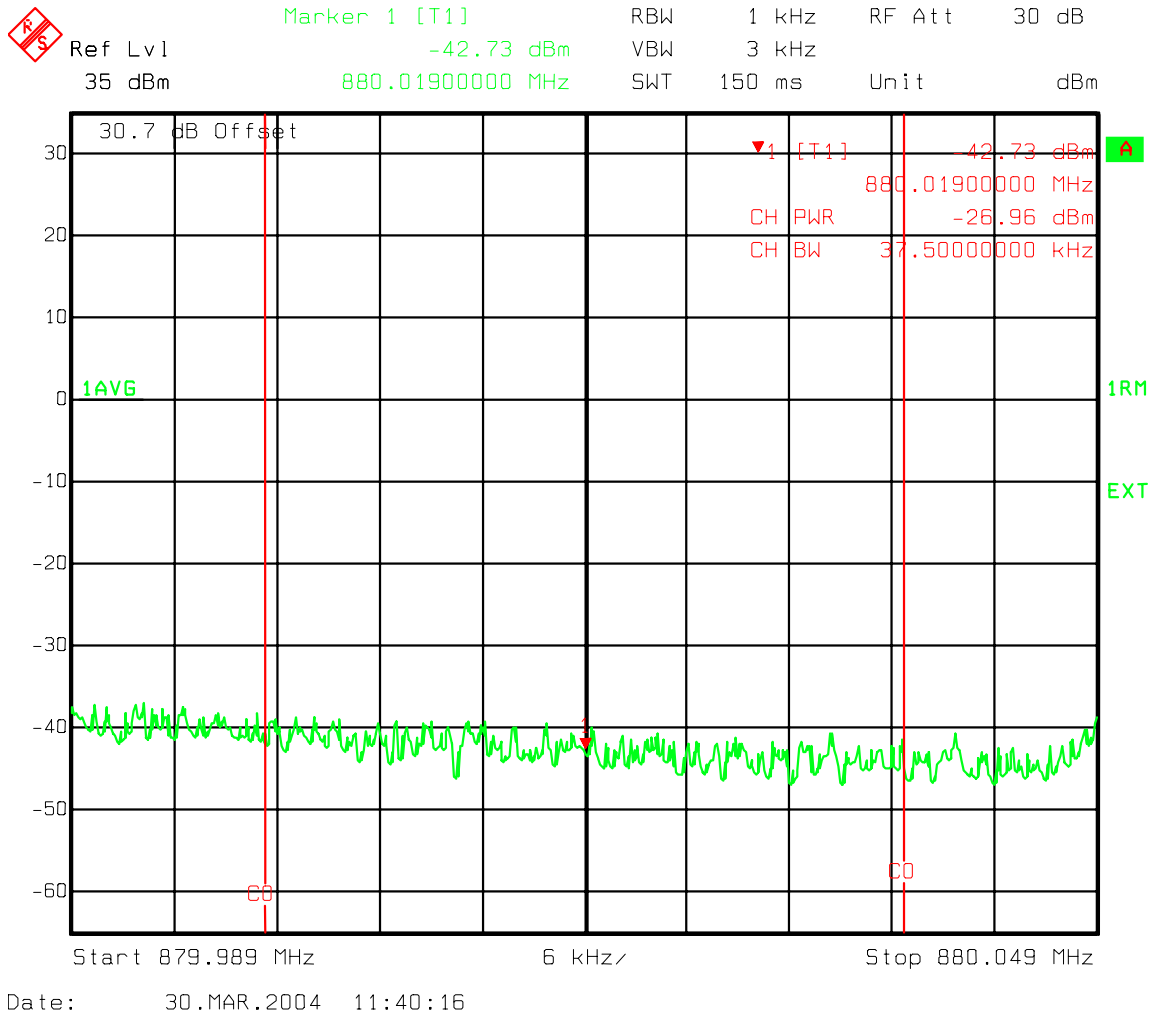
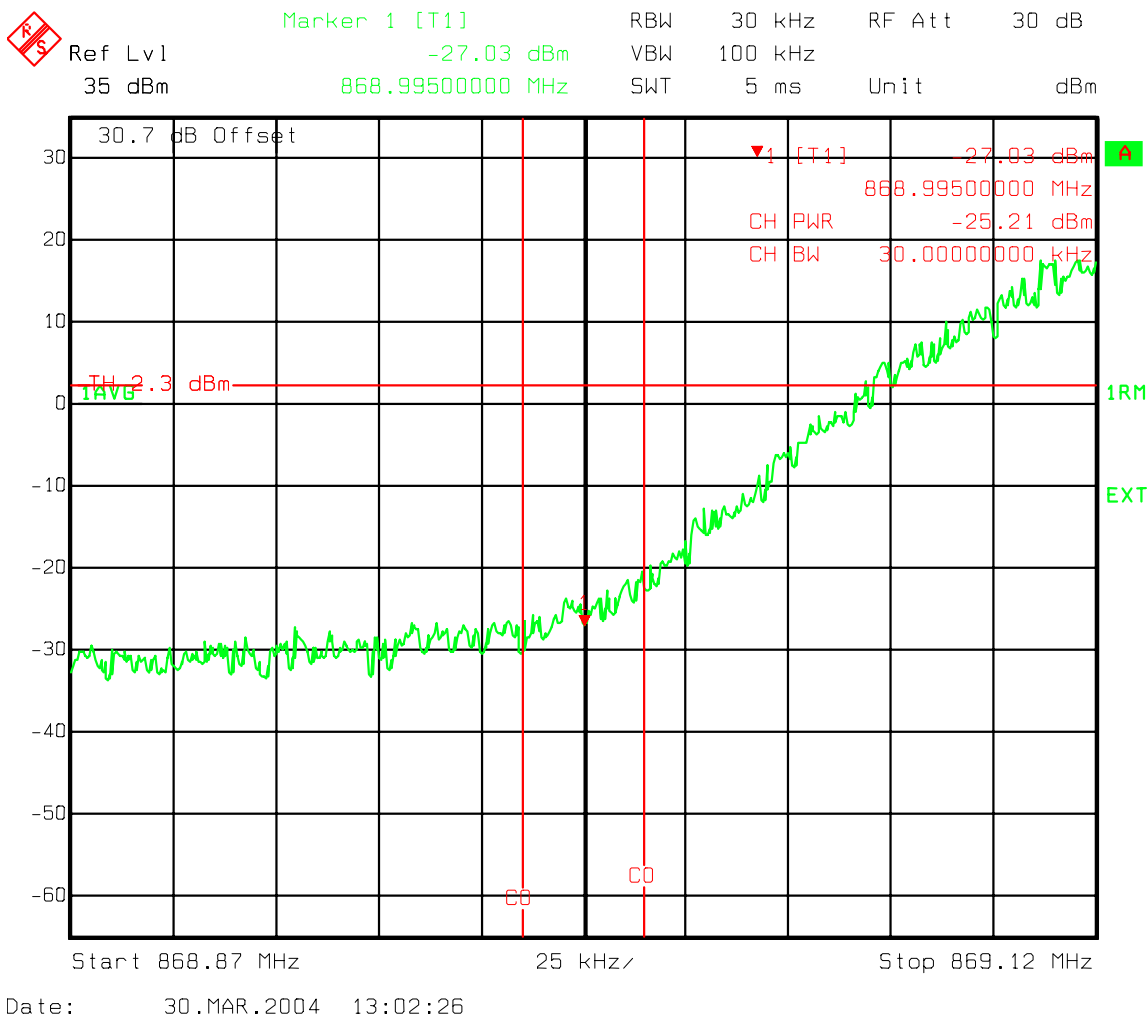

**Figure 54 : Three Carriers - Ch 226, 267, 308 Upper A Band adjacent to outside edge 37.5 kHz band Channel power**



**Three Carrier Channel 1015, 33, 74 and 226, 267, 308 Spurious Emissions at the 800 MHz MFRM1 (Maple) Ant. Port Band A and A" IS95**

**Industry Canada Lower 750 kHz offset 30 kHz Chan Power Ch 1015, 33, 74**



**Figure 55 : Three Carriers - Industry Canada Lower 750 kHz offset 30 kHz Chan Power Ch 1015, 33, 74**

**Three Carrier Channel 1015, 33, 74 and 226, 267, 308 Spurious Emissions at the 800 MHz MFRM1 (Maple) Ant. Port Band A and A" IS95**

**Industry Canada Upper 750 kHz offset 30 kHz Chan Power Ch 1015, 33, 74**

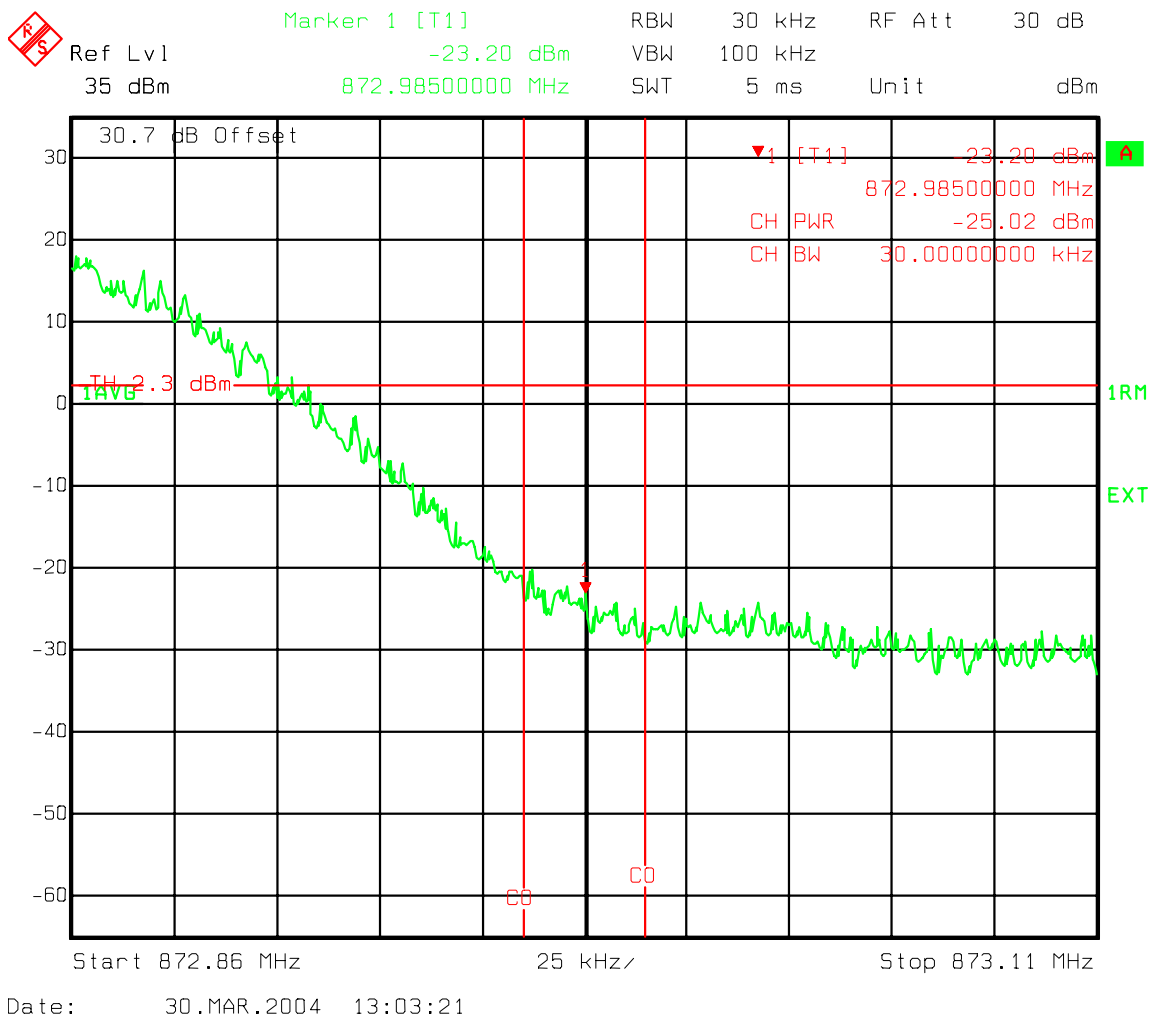

**Figure 56 : Three Carriers - Industry Canada Upper 750 kHz offset 30 kHz Chan Power Ch 1015, 33, 74**

**Three Carrier Channel 1015, 33, 74 and 226, 267, 308 Spurious Emissions at the 800 MHz MFRM1 (Maple) Ant. Port Band A and A" IS95**

**Industry Canada 1.98 MHz offset Lower 30 kHz Chan Power Ch 1015, 33, 74**

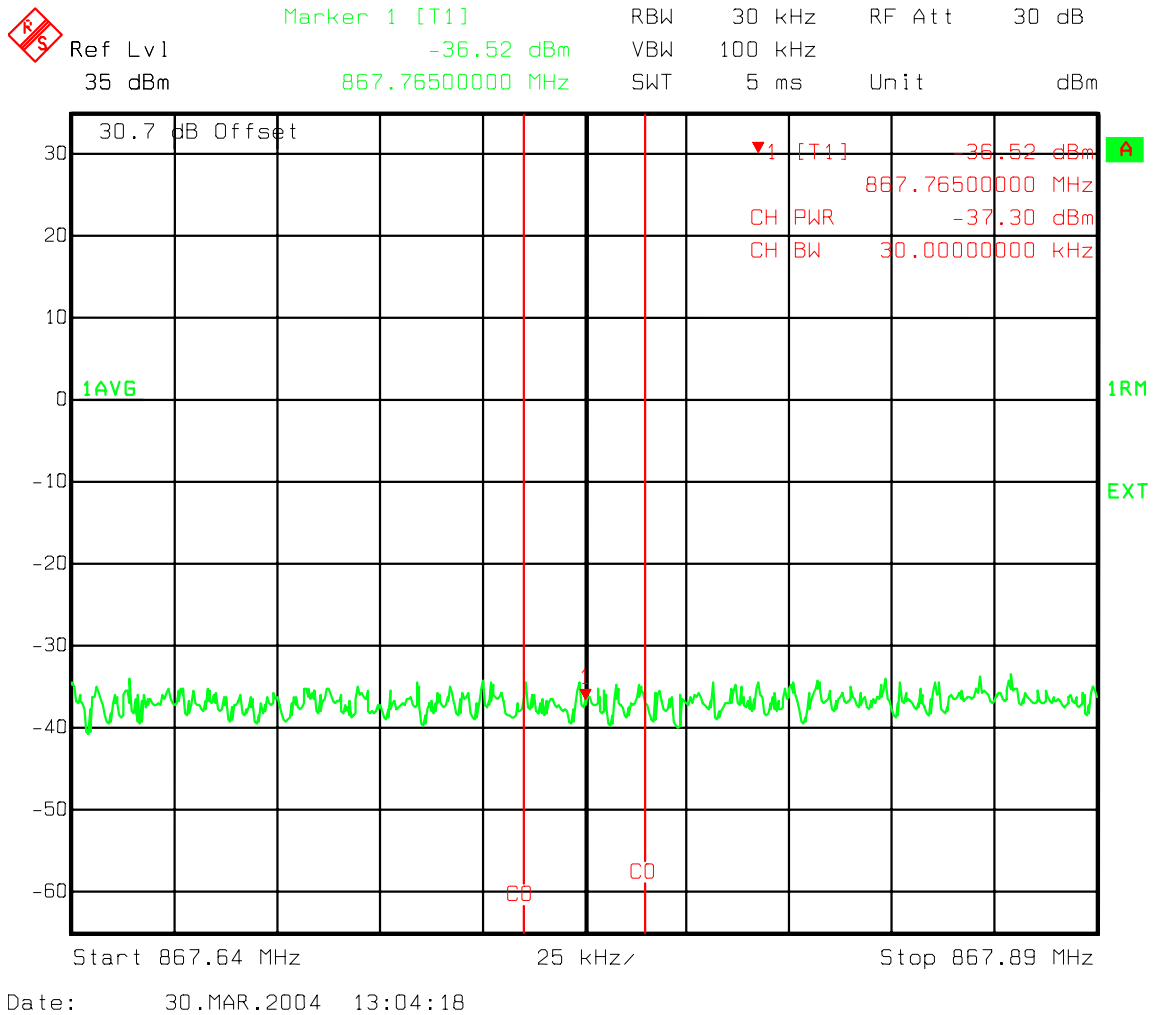

**Figure 57 : Three Carriers - Industry Canada 1.98 MHz offset Lower 30 kHz Chan Power Ch 1015, 33, 74**

**Three Carrier Channel 1015, 33, 74 and 226, 267, 308 Spurious Emissions at the 800 MHz MFRM1 (Maple) Ant. Port Band A and A" IS95**

**Industry Canada 1.98 MHz offset Upper 30 kHz Chan Power Ch 1015, 33, 74**

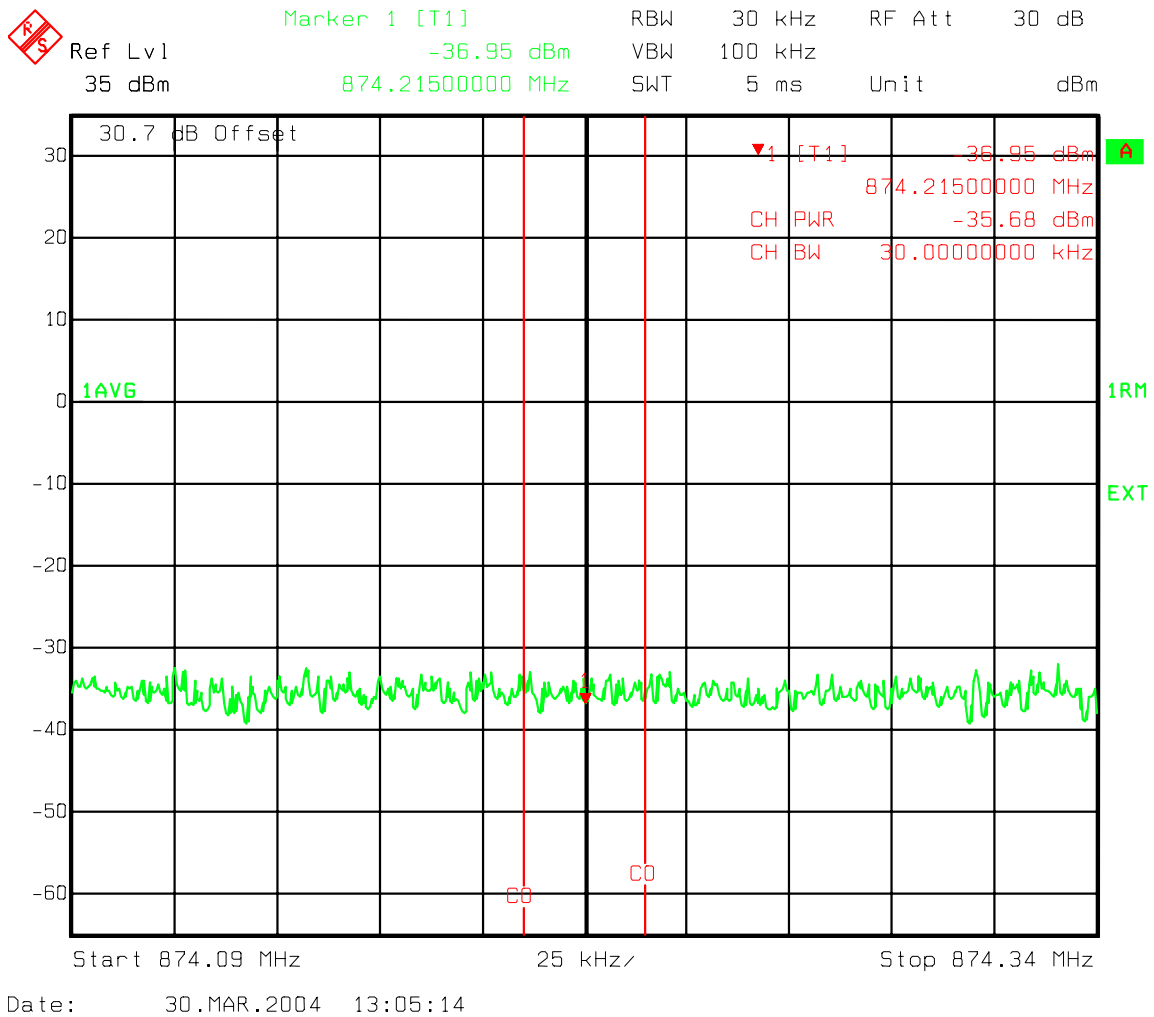
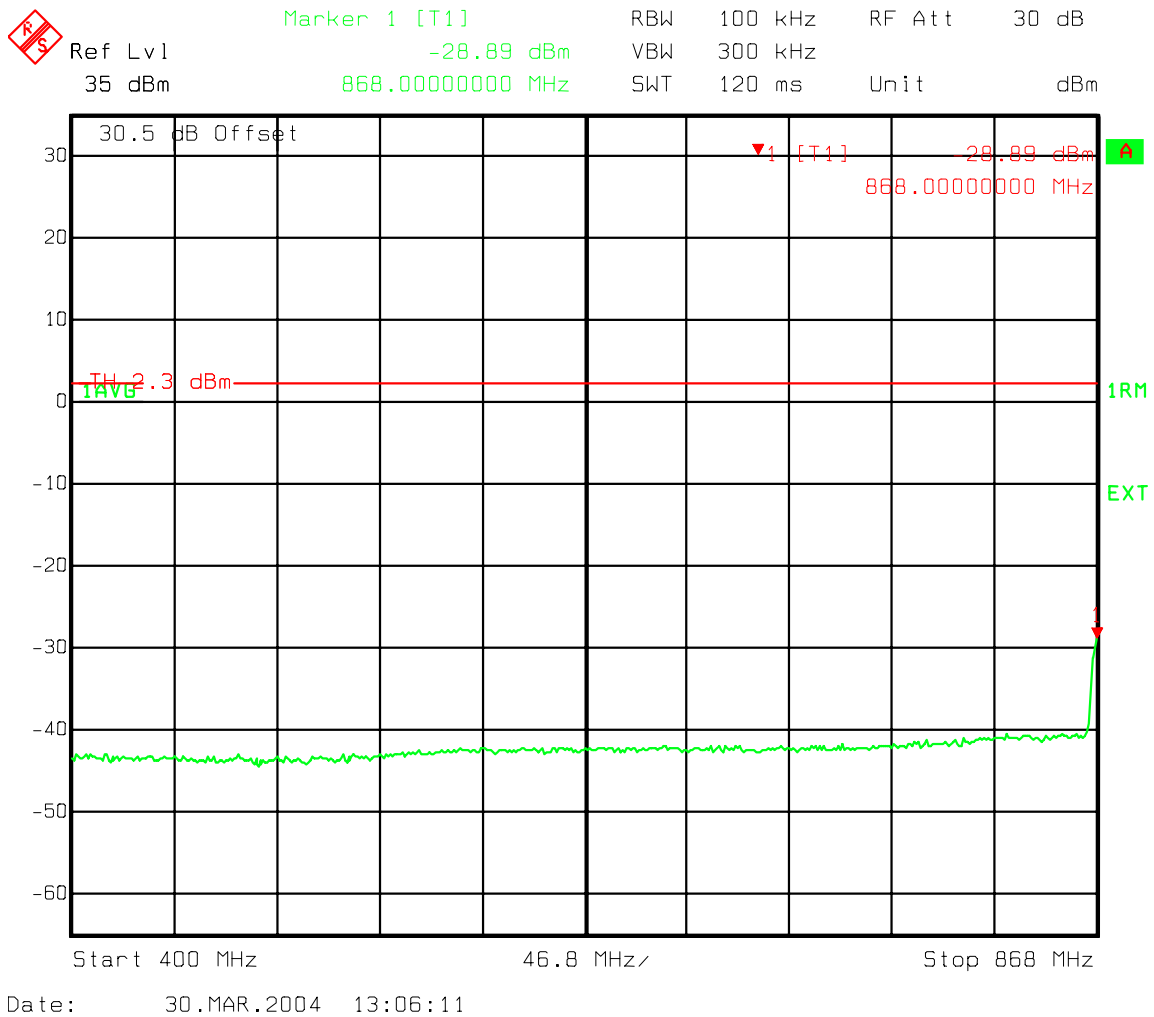

**Figure 58 : Three Carriers - Industry Canada 1.98 MHz offset Upper 30 kHz Chan Power Ch 1015, 33, 74**



**Three Carrier Channel 1015, 33, 74 and 226, 267, 308 Spurious Emissions at the 800 MHz MFRM1 (Maple) Ant. Port Band A and A" IS95**

**A " and a Band IS95 Spurious emissions 400 MHz to Lower 1 MHz Band Edge**



**Figure 60 : Three Carriers - A " and A Band IS95 Spurious emissions 400 MHz to Lower 1 MHz Band Edge**

### Three Carrier Channel 1015, 33, 74 and 226, 267, 308 Spurious Emissions at the 800 MHz MFRM1 (Maple) Ant. Port Band A and A" IS95

#### A " and a Band IS95 Spurious emissions Upper 1 MHz Band Edge to 1 GHz

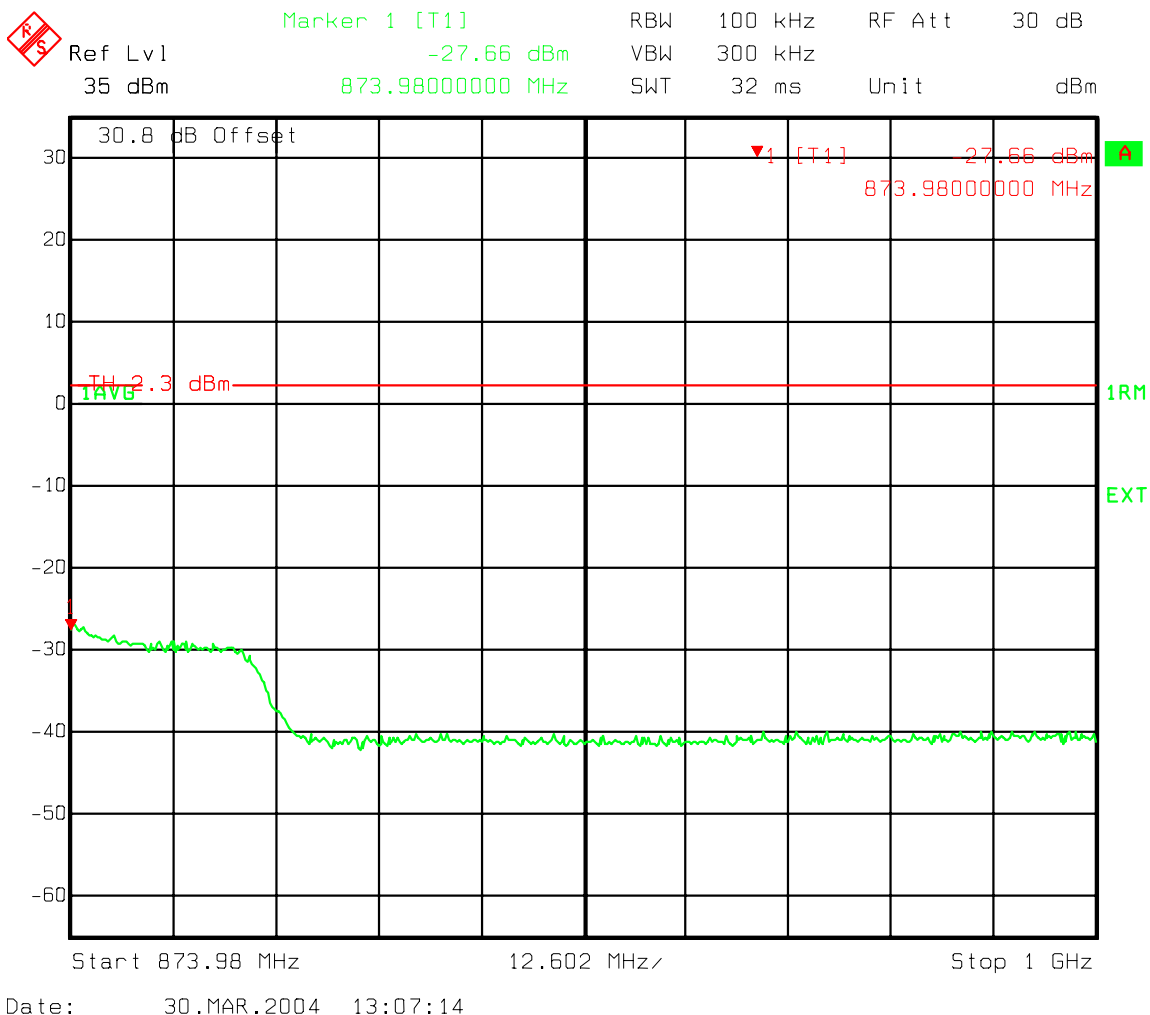

**Figure 61 : Three Carriers - A " and a Band IS95 Spurious emissions Upper 1 MHz Band Edge to 1 GHz**

**Three Carrier Channel 1015, 33, 74 and 226, 267, 308 Spurious Emissions at the 800 MHz MFRM1 (Maple) Ant. Port Band A and A'' IS95**

**A'' and A Band IS95 Spurious emissions 400-1000 MHz**

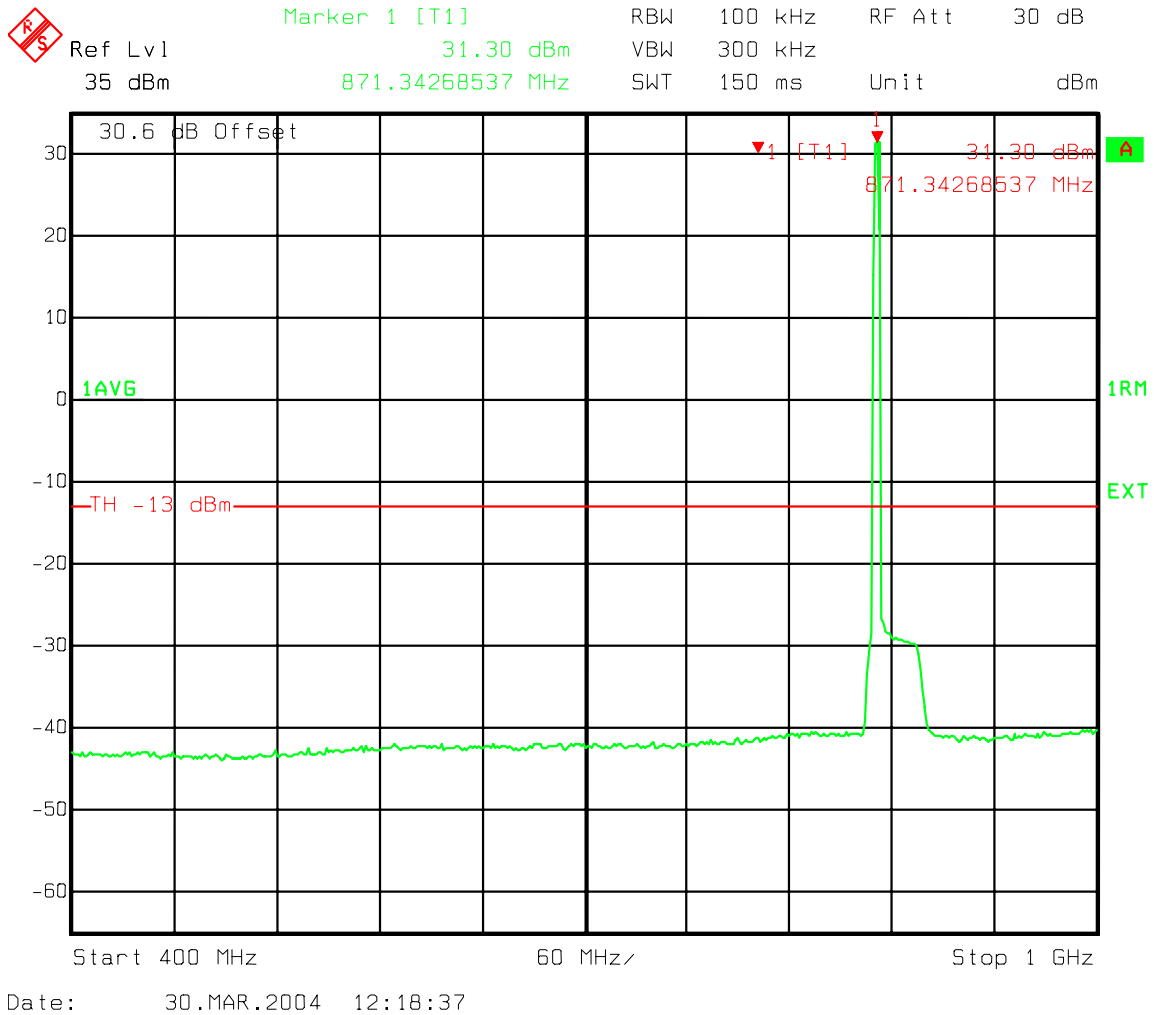
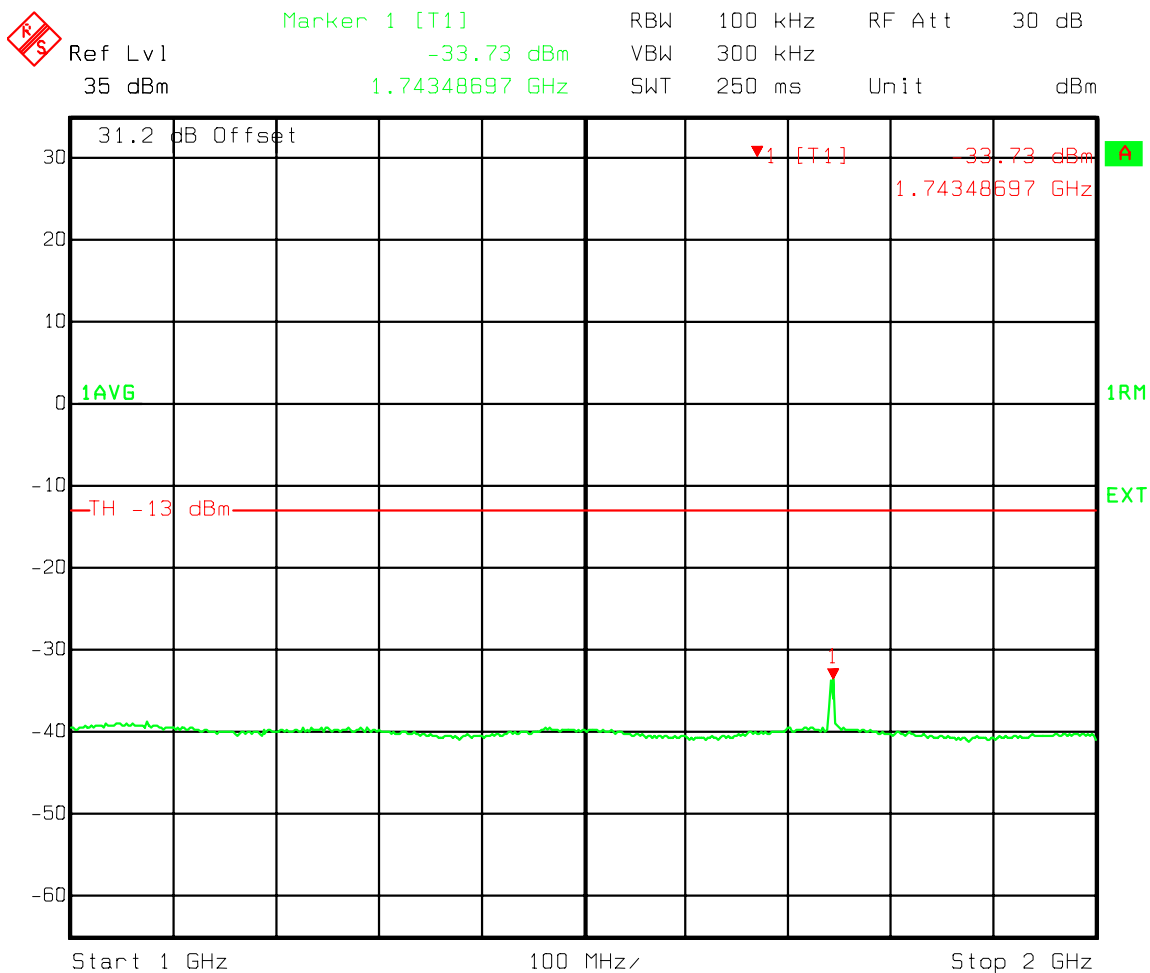

**Figure 62 : Three Carriers - A'' and A Band IS95 Spurious emissions 400-1000 MHz**



**Three Carrier Channel 1015, 33, 74 and 226, 267, 308 Spurious Emissions at the 800 MHz MFRM1 (Maple) Ant. Port Band A and A'' IS95**

**A'' and A Band IS95 Spurious emissions 1000-2000 MHz**



Date: 30.MAR.2004 12:19:17

**Figure 63 : Three Carriers - A'' and A Band IS95 Spurious emissions 1000-2000 MHz**

**Three Carrier Channel 1015, 33, 74 and 226, 267, 308 Spurious Emissions at the 800 MHz MFRM1 (Maple) Ant. Port Band A and A'' IS95**

**A'' and A Band IS95 Spurious emissions 2000-3000 MHz**

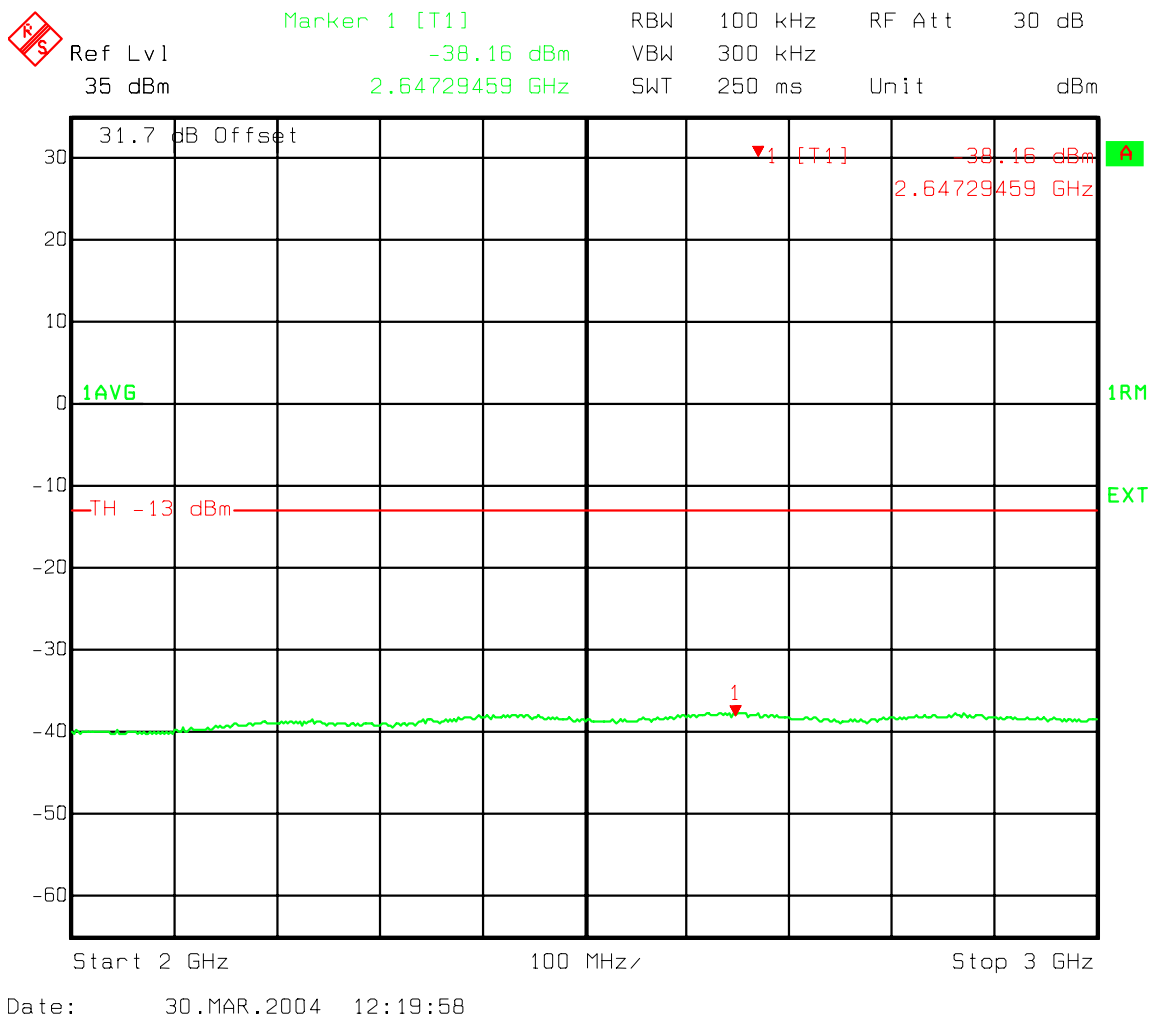

**Figure 64 : Three Carriers - A'' and A Band IS95 Spurious emissions 2000-3000 MHz**

**Three Carrier Channel 1015, 33, 74 and 226, 267, 308 Spurious Emissions at the 800 MHz MFRM1 (Maple) Ant. Port Band A and A'' IS95**

**A'' and A Band IS95 Spurious emissions 3000-4000 MHz**

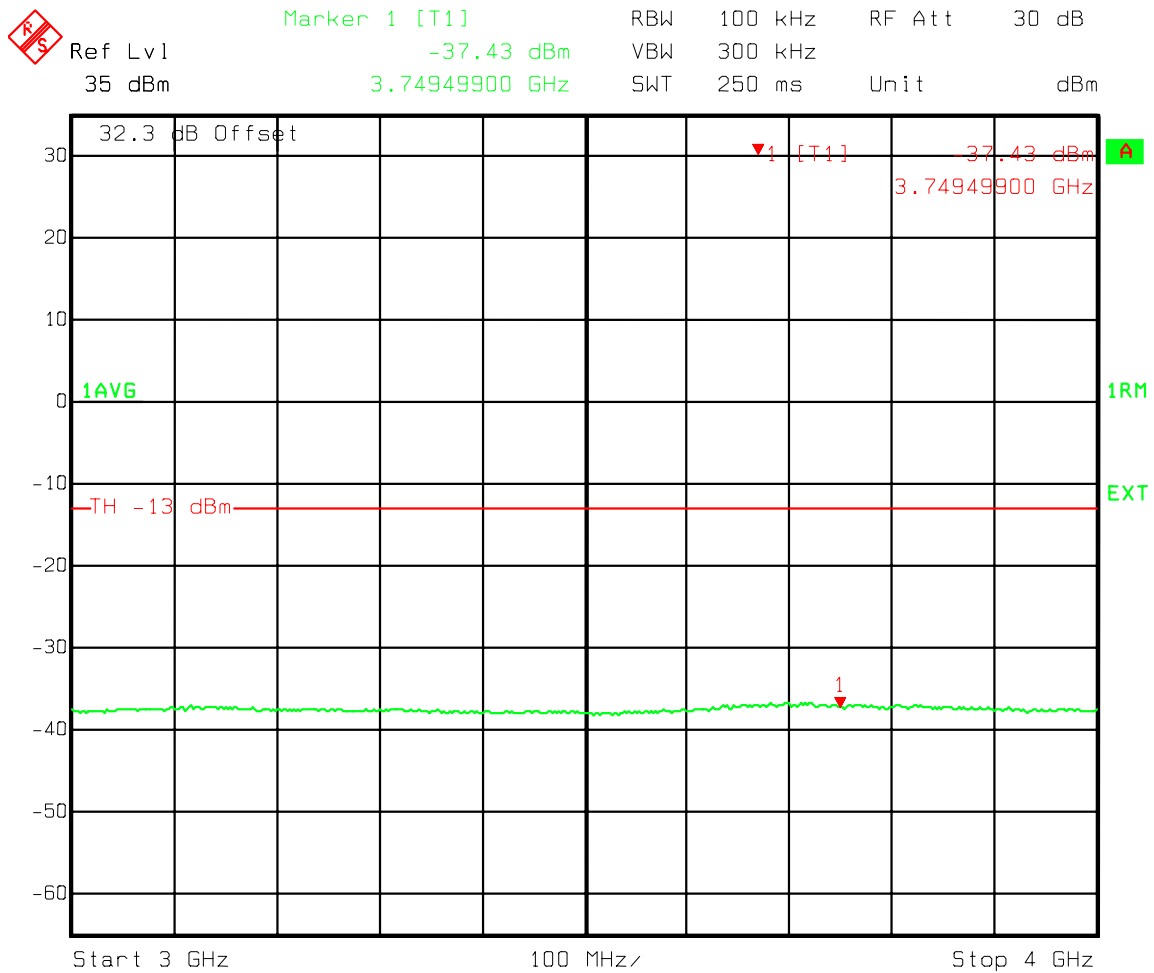

Date: 30.MAR.2004 12:20:38

**Figure 65 : Three Carriers - A'' and A Band IS95 Spurious emissions 3000-4000 MHz**

**Three Carrier Channel 1015, 33, 74 and 226, 267, 308 Spurious Emissions at the 800 MHz MFRM1 (Maple) Ant. Port Band A and A'' IS95**

**A'' and A Band IS95 Spurious emissions 4000-5000 MHz**

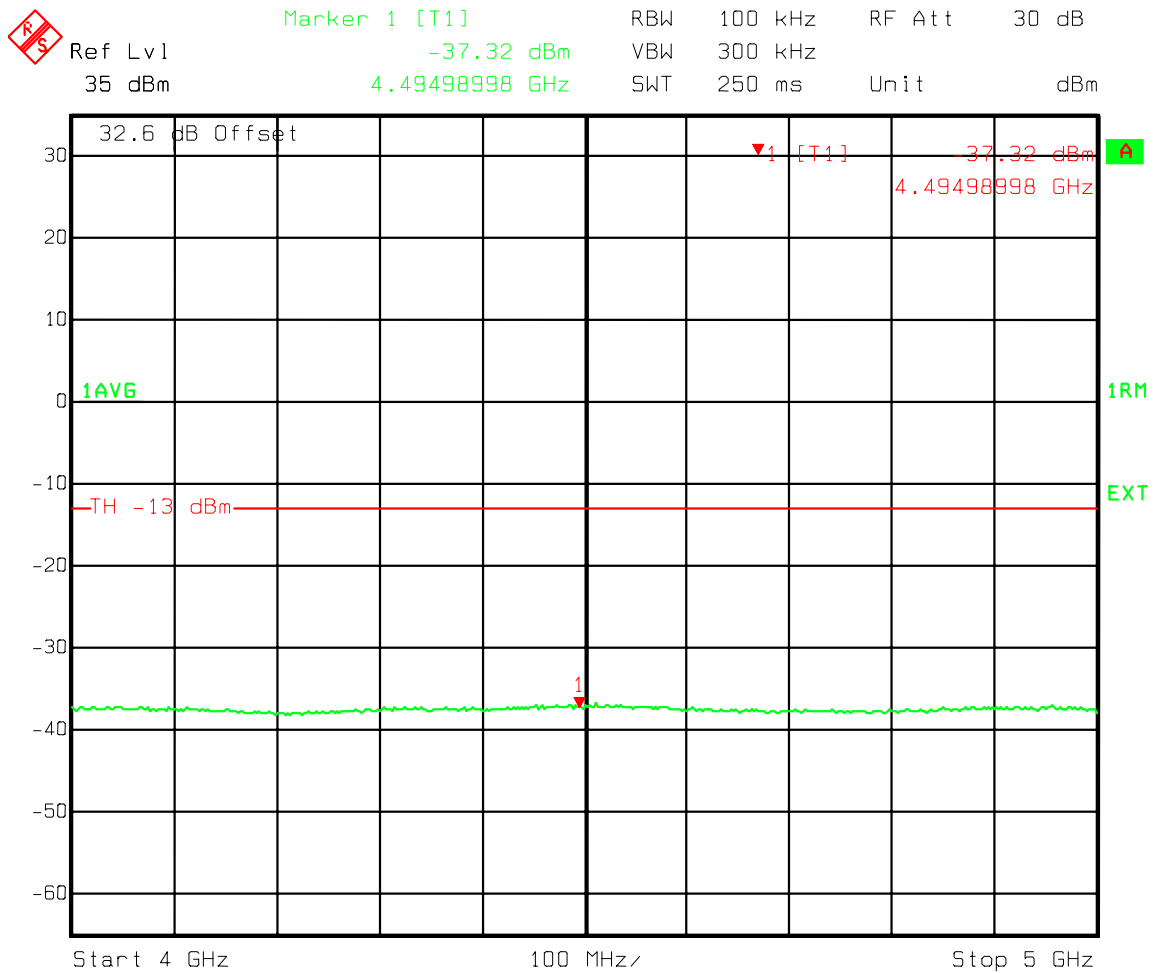

Date: 30.MAR.2004 12:21:19

**Figure 66 : Three Carriers - A'' and A Band IS95 Spurious emissions 4000-5000 MHz**

### Three Carrier Channel 1015, 33, 74 and 226, 267, 308 Spurious Emissions at the 800 MHz MFRM1 (Maple) Ant. Port Band A and A'' IS95

#### A'' and A Band IS95 Spurious emissions 5000-6000 MHz

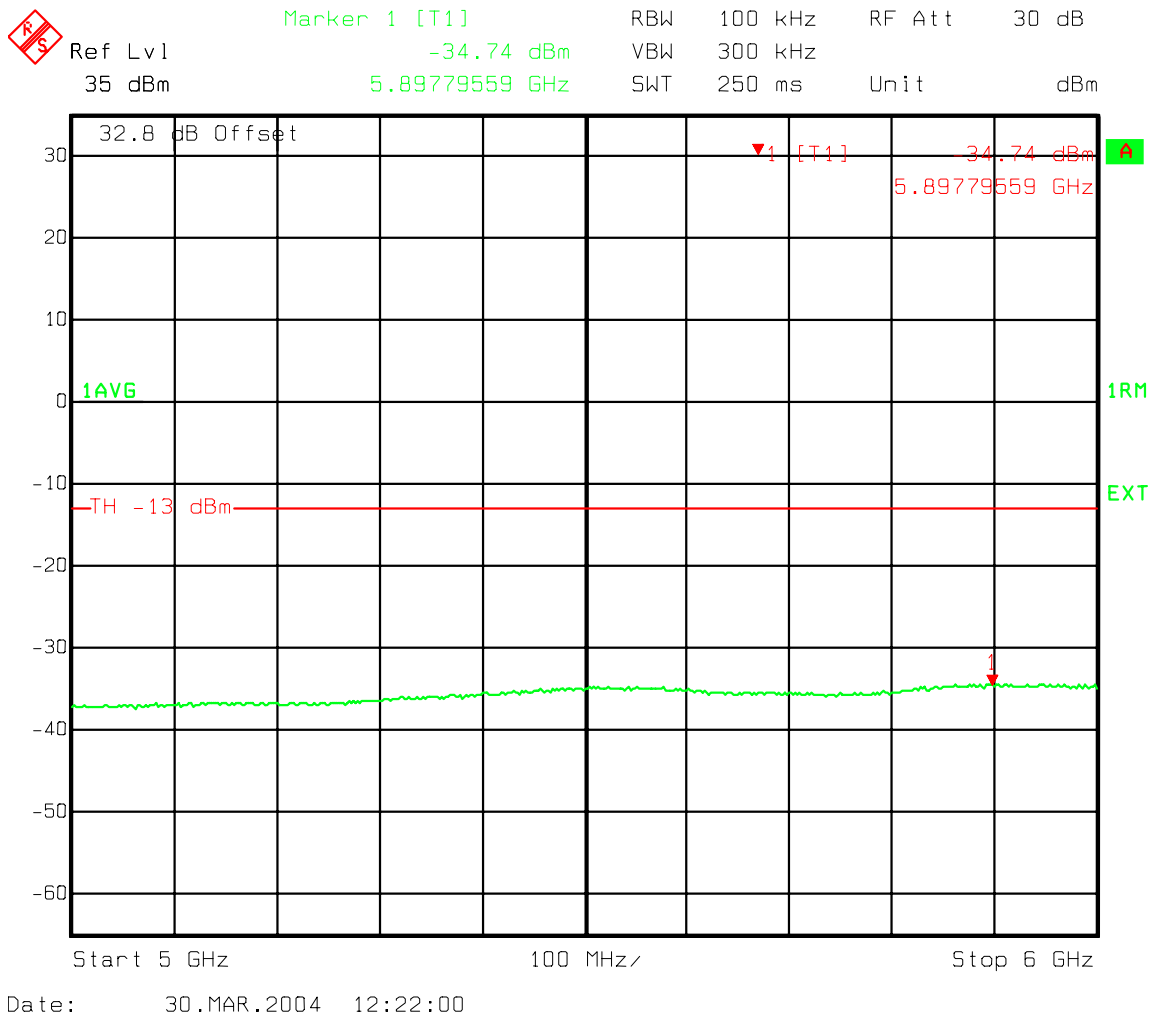
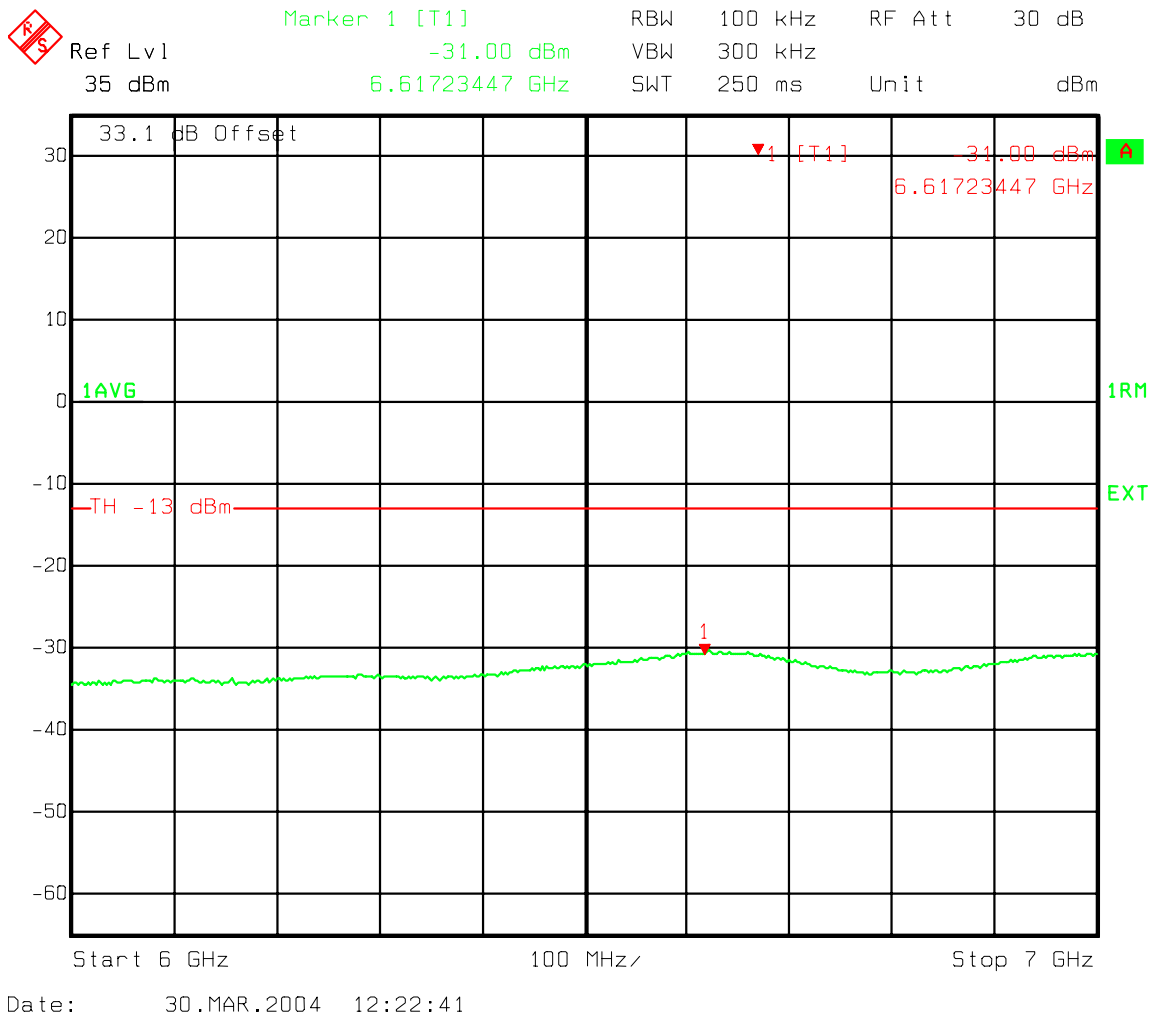

Figure 67 : Three Carriers - A'' and A Band IS95 Spurious emissions 5000-6000 MHz

**Three Carrier Channel 1015, 33, 74 and 226, 267, 308 Spurious Emissions at the 800 MHz MFRM1 (Maple) Ant. Port Band A and A'' IS95**

**A'' and A Band IS95 Spurious emissions 6000-7000 MHz**



**Figure 68 : Three Carriers - A'' and A Band IS95 Spurious emissions 6000-7000 MHz**

**Three Carrier Channel 1015, 33, 74 and 226, 267, 308 Spurious Emissions at the 800 MHz MFRM1 (Maple) Ant. Port Band A and A'' IS95**

**A'' and A Band IS95 Spurious emissions 7000-8000 MHz**

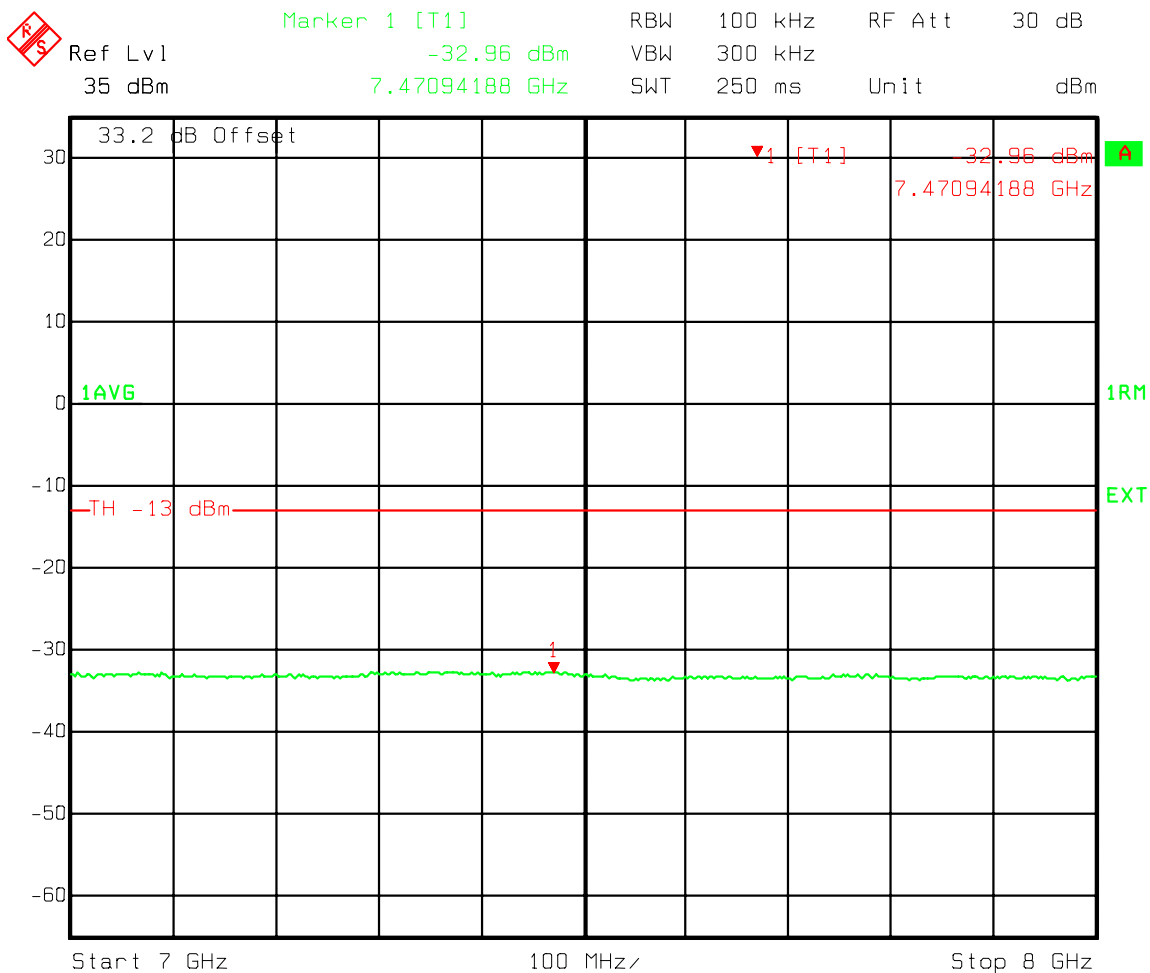

Date: 30.MAR.2004 12:23:23

**Figure 69 : Three Carriers - A'' and A Band IS95 Spurious emissions 7000-8000 MHz**

**Three Carrier Channel 1015, 33, 74 and 226, 267, 308 Spurious Emissions at the 800 MHz MFRM1 (Maple) Ant. Port Band A and A'' IS95**

**A'' and A Band IS95 Spurious emissions 8000-9000 MHz**

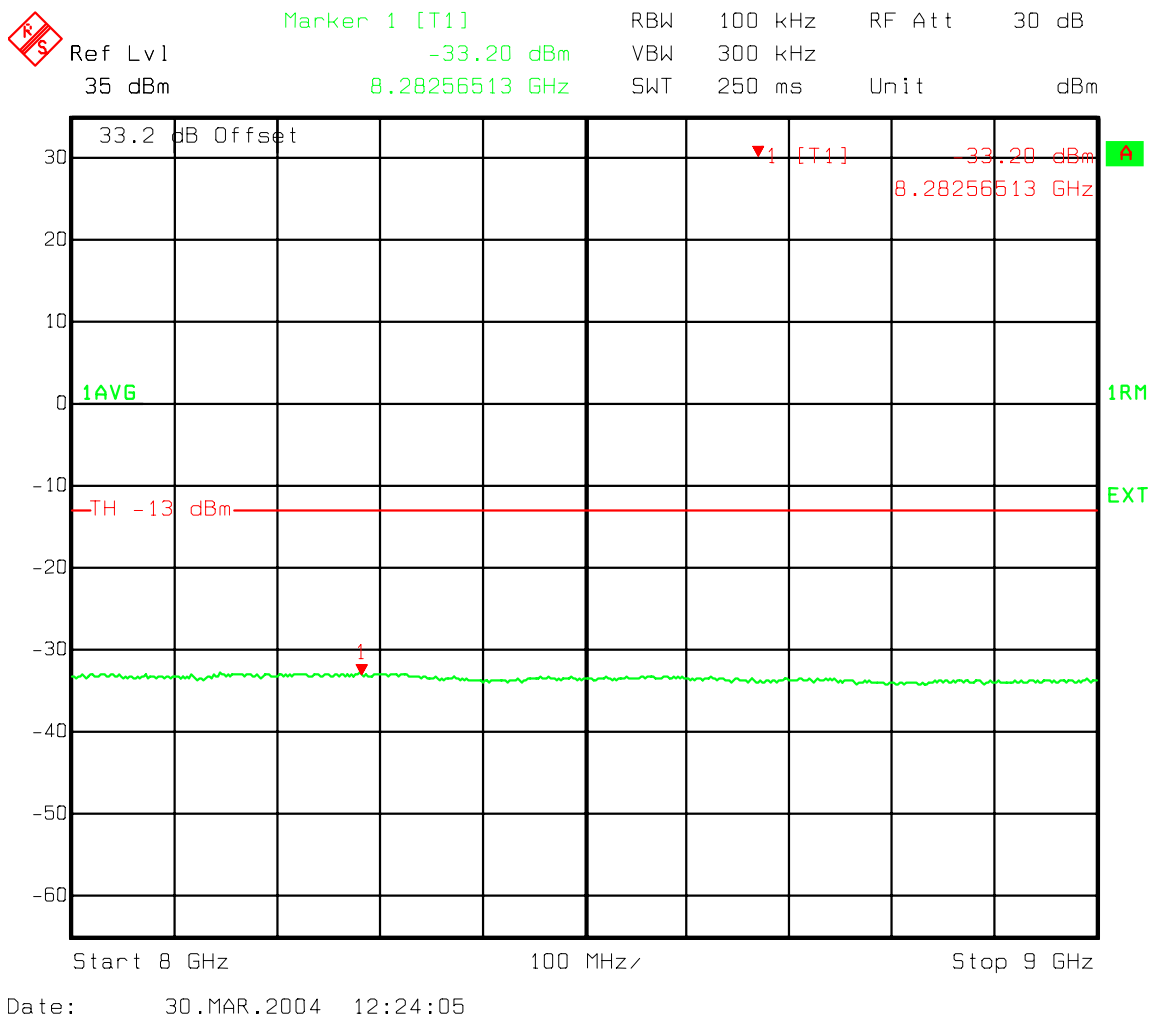
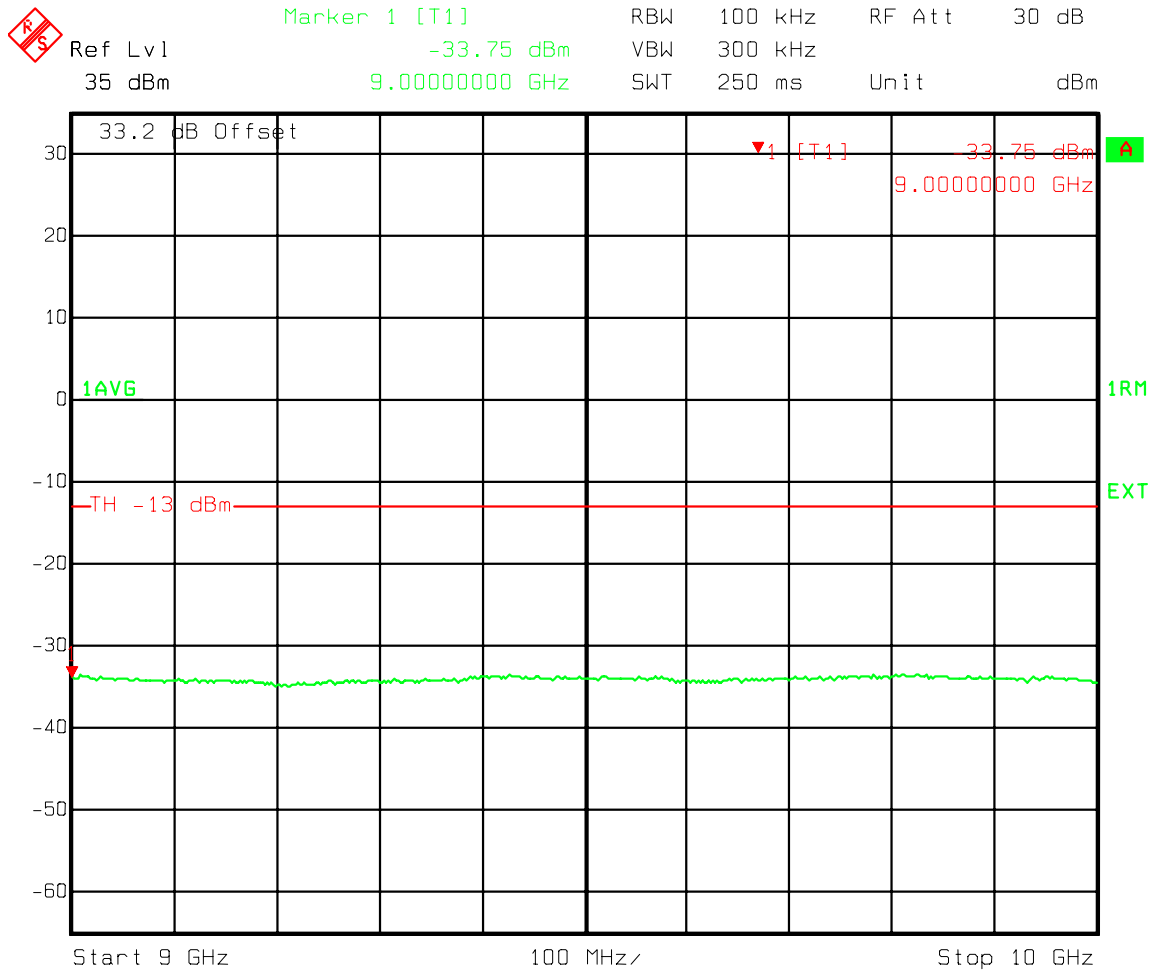

**Figure 70 : Three Carriers - A'' and A Band IS95 Spurious emissions 8000-9000 MHz**



**Three Carrier Channel 1015, 33, 74 and 226, 267, 308 Spurious Emissions at the 800 MHz MFRM1 (Maple) Ant. Port Band A and A'' IS95**

**A'' and A Band IS95 Spurious emissions 9000-10000 MHz**



Date: 30.MAR.2004 12:24:47

**Figure 71 : Three Carriers - A'' and A Band IS95 Spurious emissions 9000-10000 MHz**

## 8 Appendix D - One Carrier IS-856 16QAM Spurious Emission

Single Chan 358 and 642 Spurious Emissions at the 800 MHz MFRM1 Maple Ant.  
 Port one Carrier Band B IS 856

### Occupied Bandwidth Ch 358 IS856 B Band

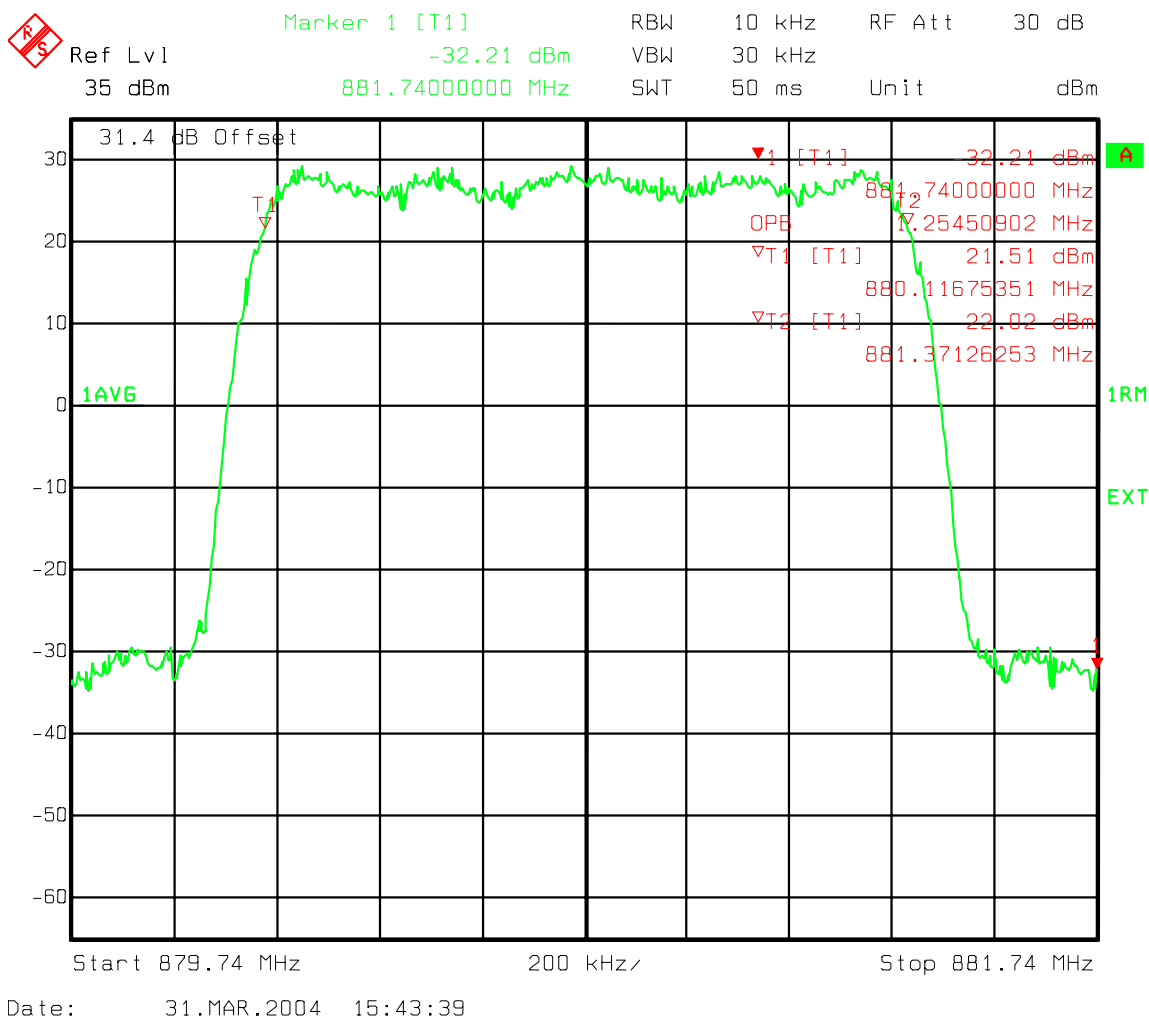
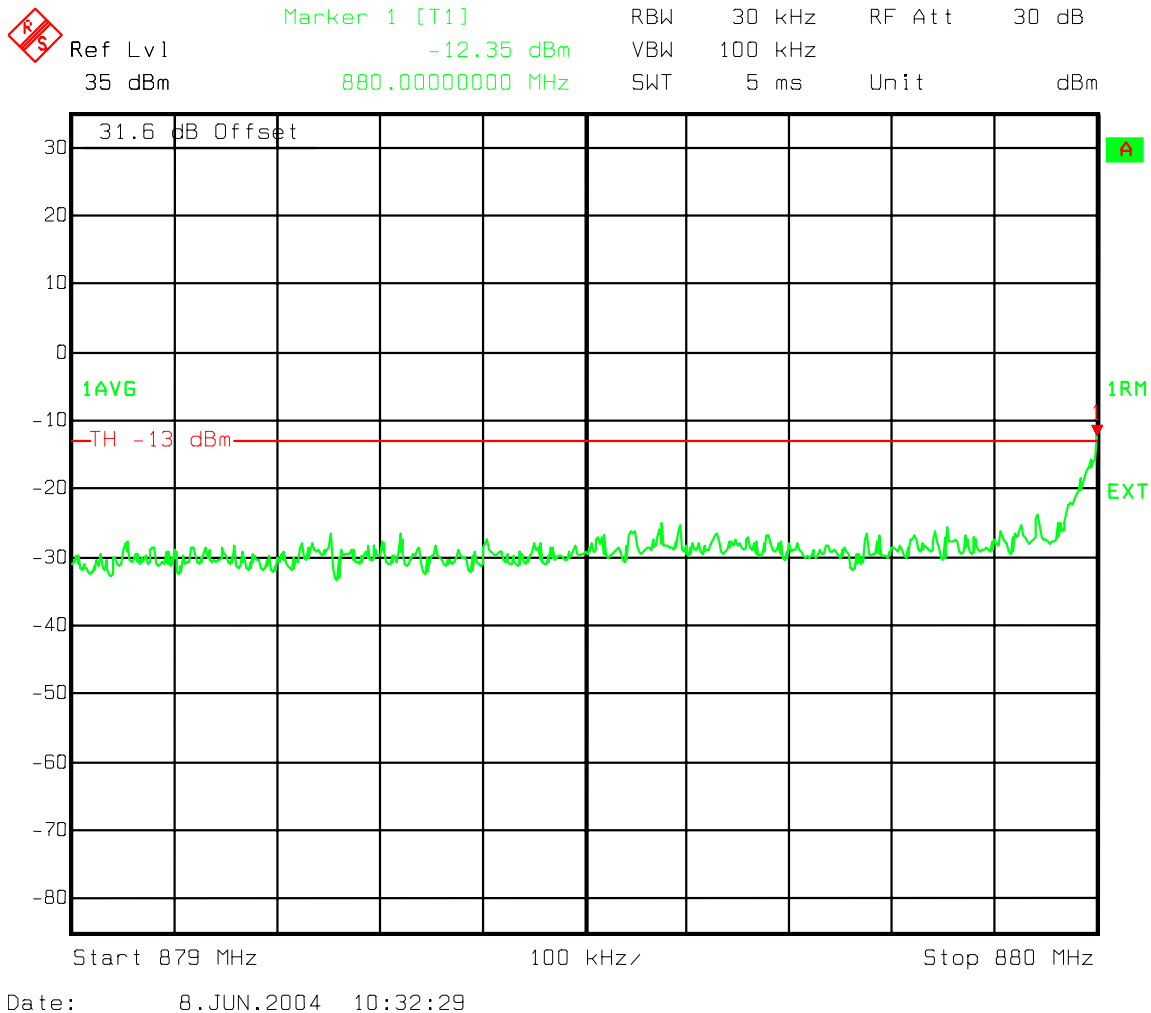

Figure 72 : 1 Carrier - Occupied Bandwidth Channel 358

**Single Chan 358 and 642 Spurious Emissions at the 800 MHz MFRM1 Maple Ant.  
 Port one Carrier Band B IS 856**

**B Band Ch 358 IS856 Adjacent 1MHz Lower emissions 879-880MHz**



**Figure 73 : One Carrier - B Band Ch 358 IS856 Adjacent 1 MHz Lower emissions 879-880 MHz**

**Single Chan 358 and 642 Spurious Emissions at the 800 MHz MFRM1 Maple Ant.  
 Port one Carrier Band B IS 856**

**B Band Ch358 IS856 Adjacent 30kHz Lower emissions to 880 MHz**

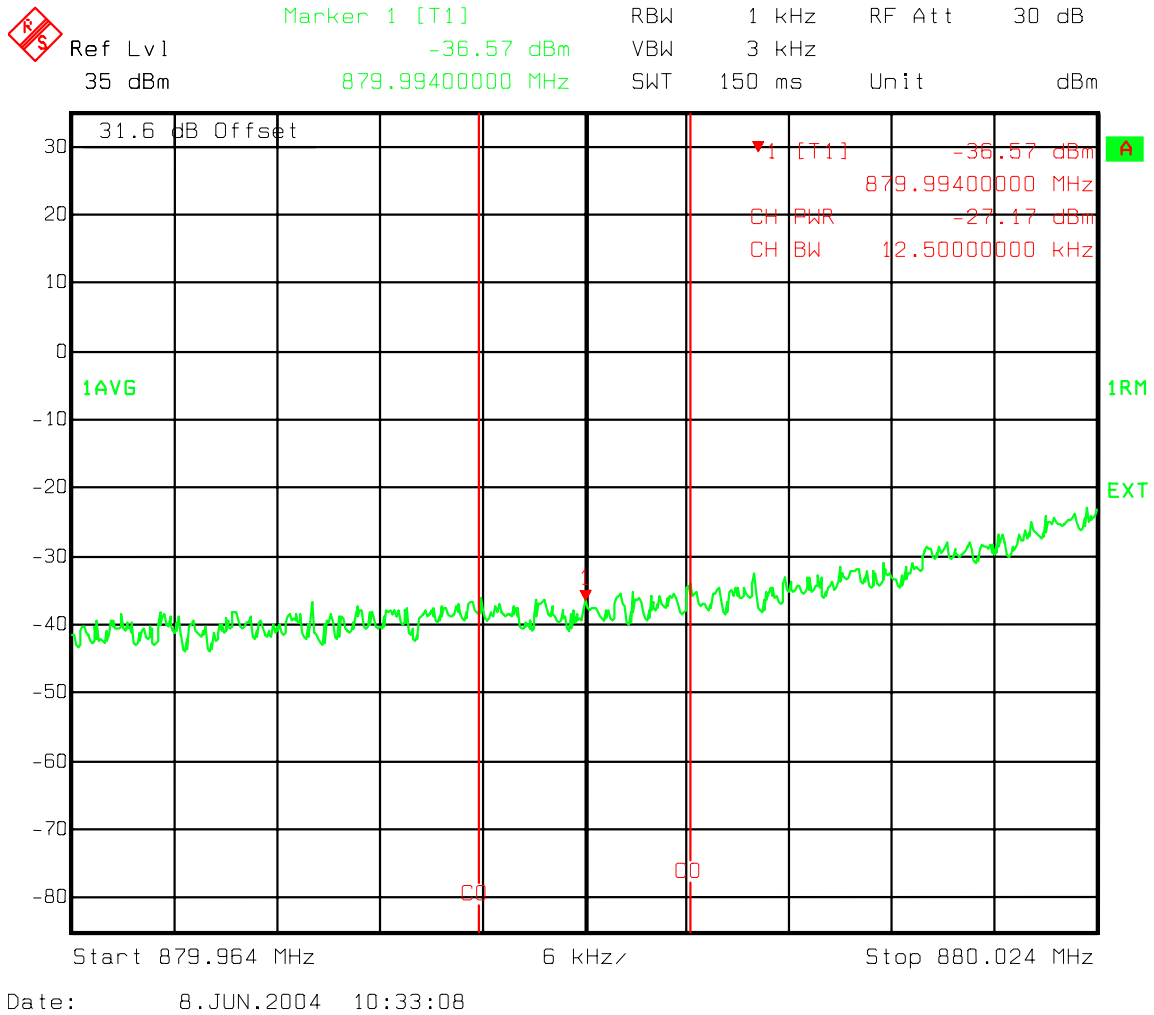

**Figure 74 : One Carrier - Ch3585 IS856 Lower B Band Adjacent to outside edge 12.5kHz band Channel Power**

**Single Chan 358 and 642 Spurious Emissions at the 800 MHz MFRM1 Maple Ant.  
Port one Carrier Band B IS 856**

**Ch 642 Upper B Band adjacent 1MHz band emissions**

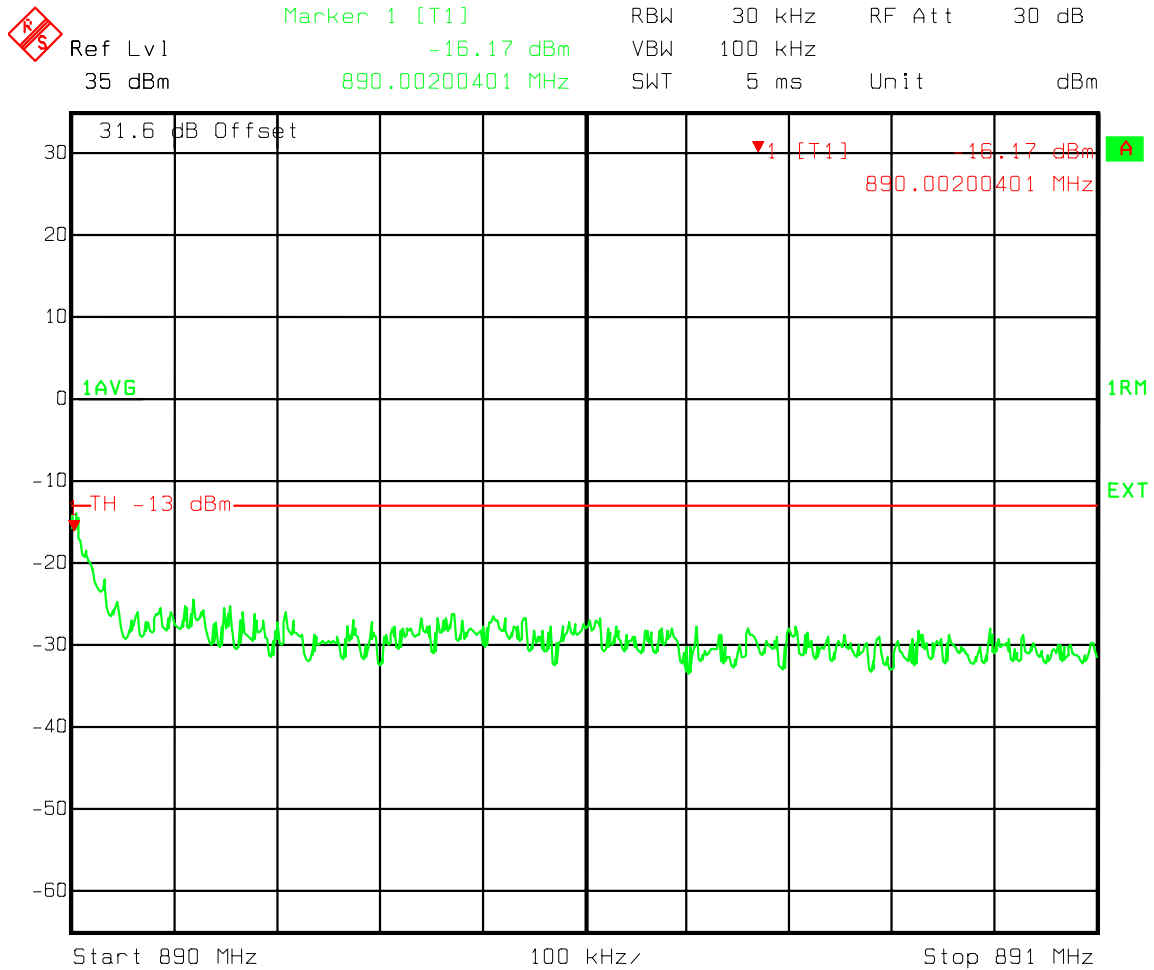

Date: 31.MAR.2004 16:51:50

**Figure 75 : One Carrier - Ch 642 Upper A Band adjacent 1MHz band emissions**

**Single Chan 358 and 642 Spurious Emissions at the 800 MHz MFRM1 Maple Ant.  
 Port one Carrier Band B IS 856**

**Ch 642 Upper B Band adjacent to outside edge 12.5 kHz band Channel power**

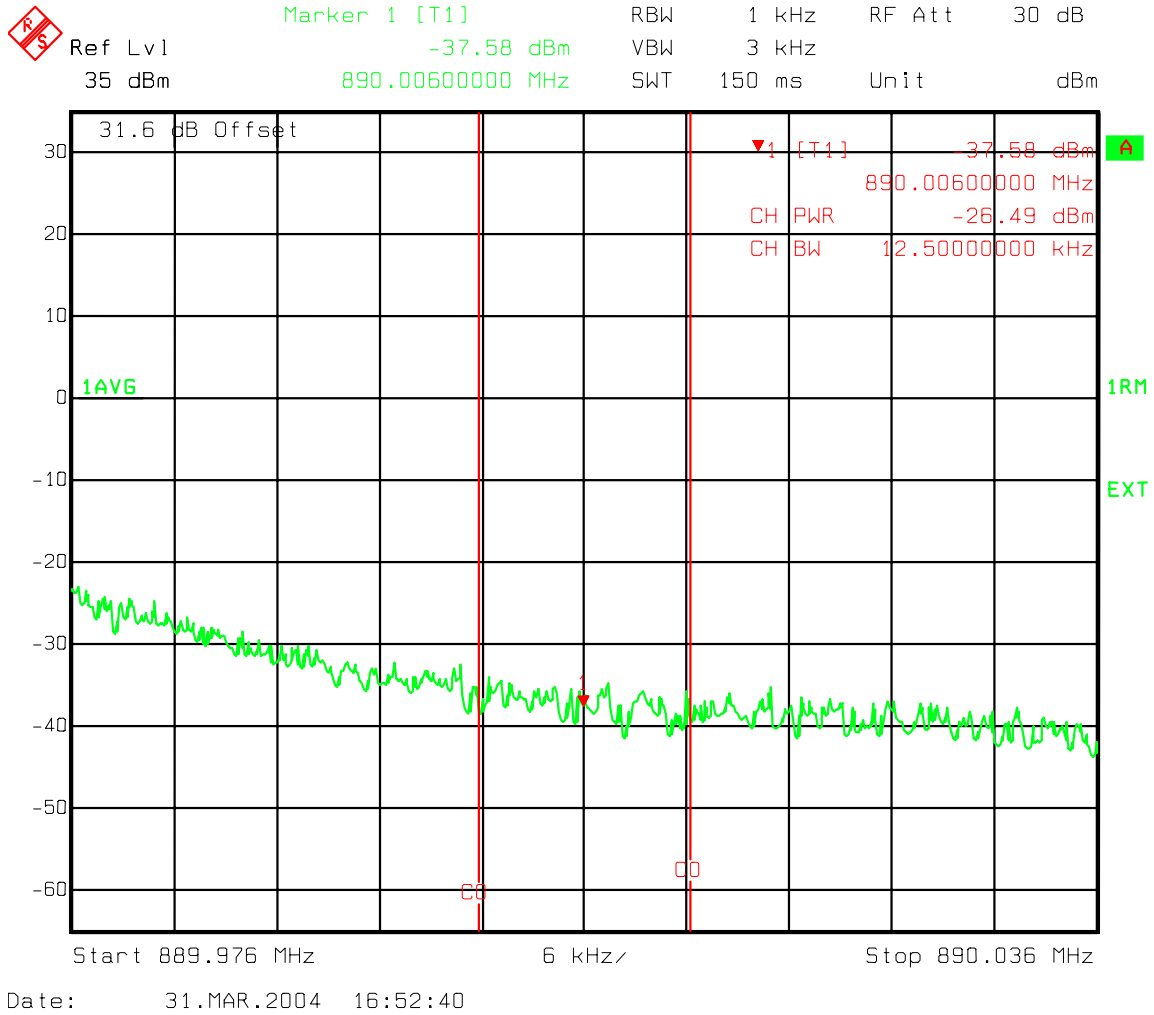

**Figure 76 : One Carrier - Ch 642 Upper B Band adjacent to outside edge 12.5 kHz band Channel power**

**Single Chan 358 and 642 Spurious Emissions at the 800 MHz MFRM1 Maple Ant.  
Port one Carrier Band B IS 856**

**Industry Canada Lower 750 kHz offset 30kHz Chan Power Ch 358**

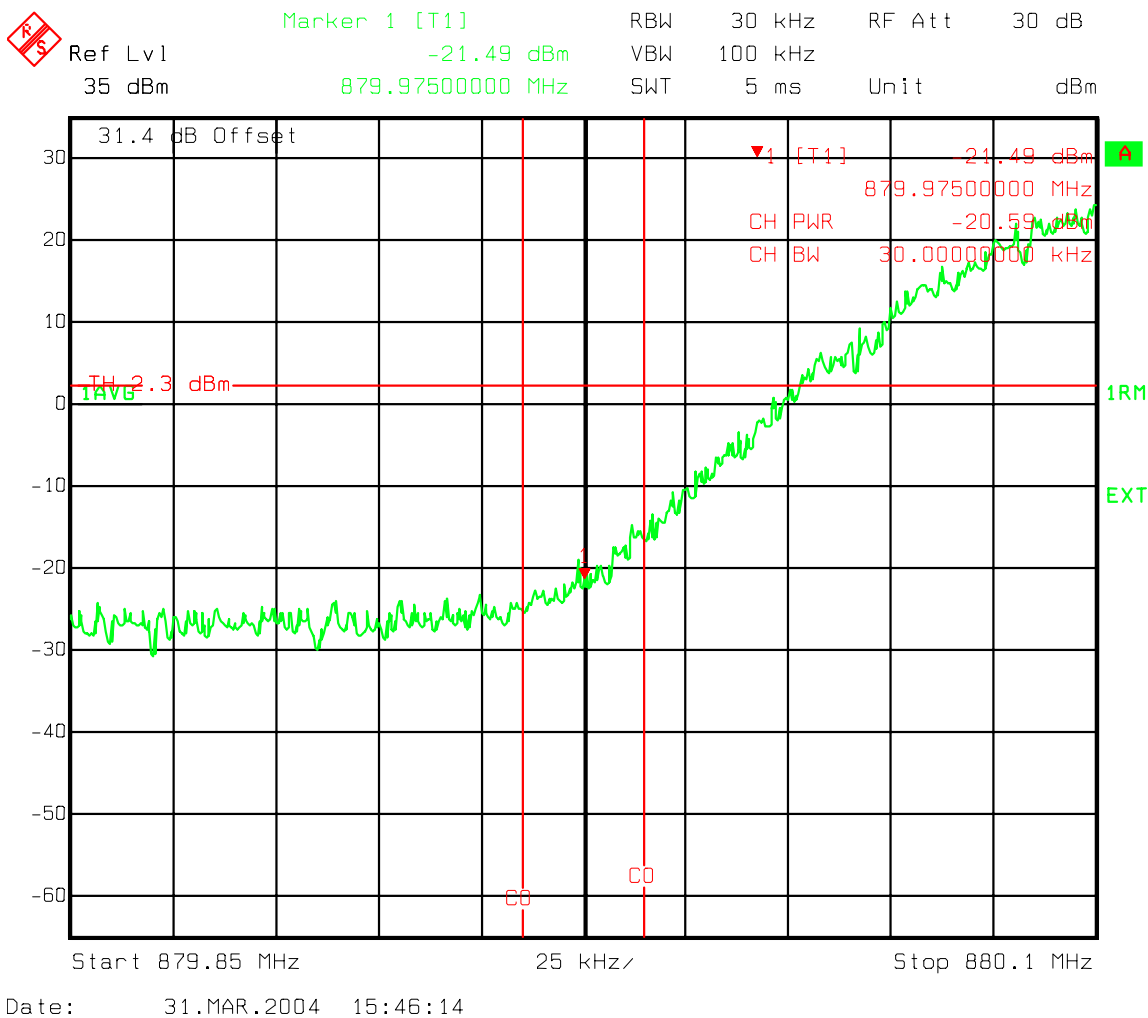

**Figure 77 : One Carrier - Industry Canada Lower 750 kHz offset 30 kHz Chan Power Ch 358**

**Single Chan 358 and 642 Spurious Emissions at the 800 MHz MFRM1 Maple Ant.  
 Port one Carrier Band B IS 856**

**Industry Canada Upper 750 kHz offset 30kHzChan Power Ch 358**

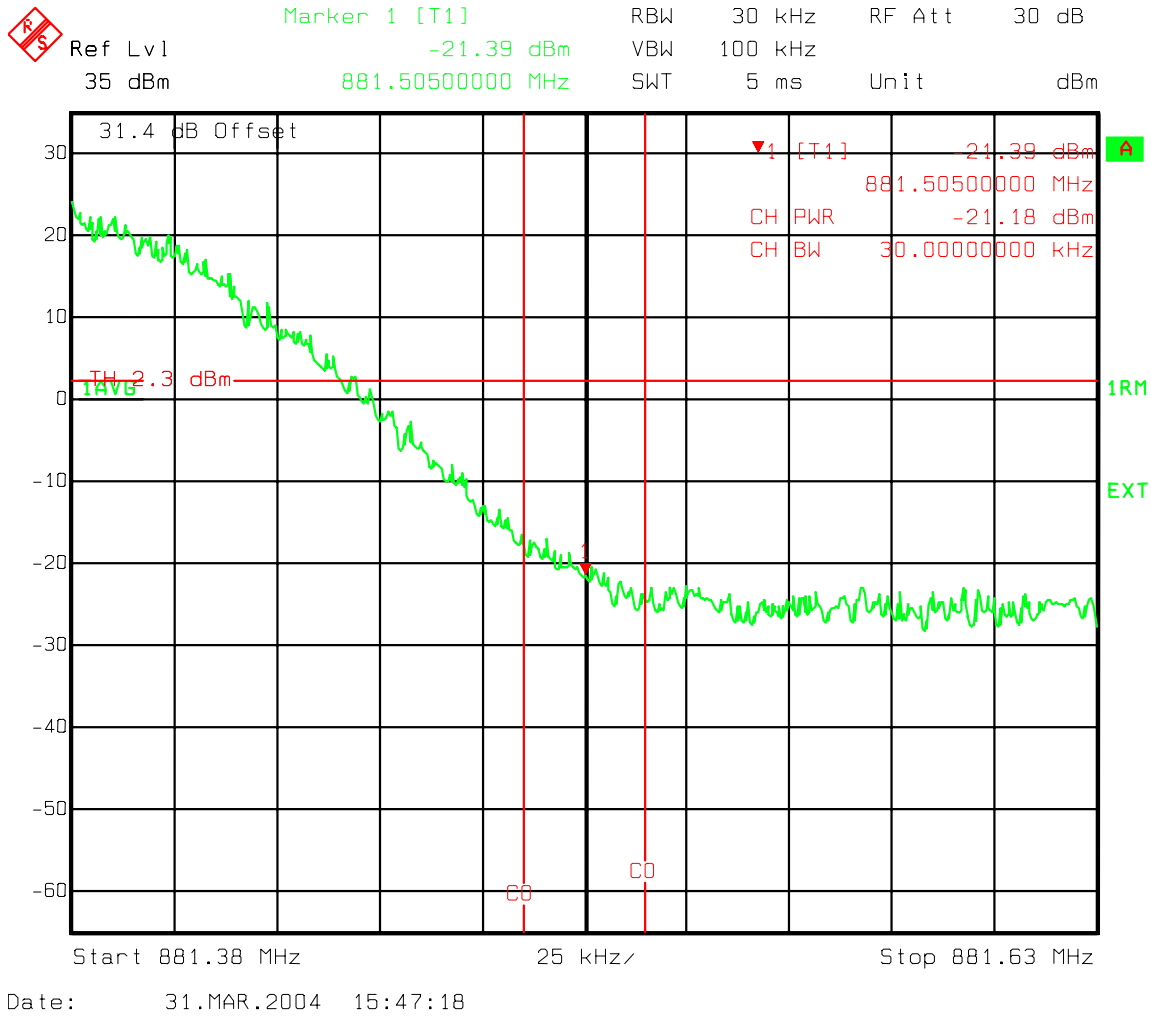
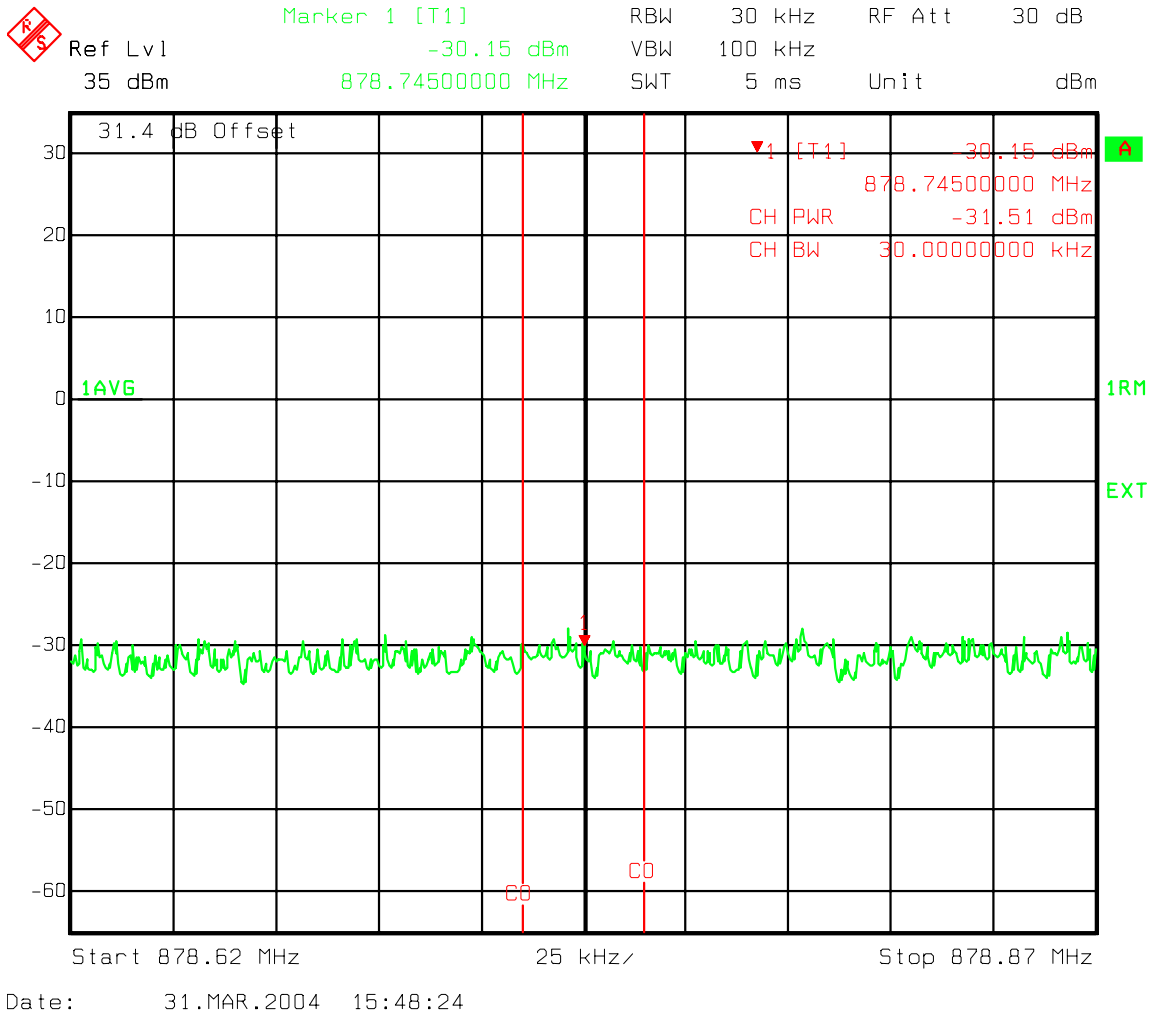

**Figure 78 : One Carrier - Industry Canada Upper 750 kHz offset 30 kHz Chan Power Ch 358**



**Single Chan 358 and 642 Spurious Emissions at the 800 MHz MFRM1 Maple Ant.  
Port one Carrier Band B IS 856**

**Industry Canada 1.98 MHz offset Lower 30kHzChan Power Ch 358**



**Figure 79 : One Carrier - Industry Canada 1.98 MHz offset Lower 30 kHz Chan Power Ch 358**

**Single Chan 358 and 642 Spurious Emissions at the 800 MHz MFRM1 Maple Ant.  
 Port one Carrier Band B IS 856**

**Industry Canada 1.98 MHz offset Upper 30kHzChan Power Ch 358**

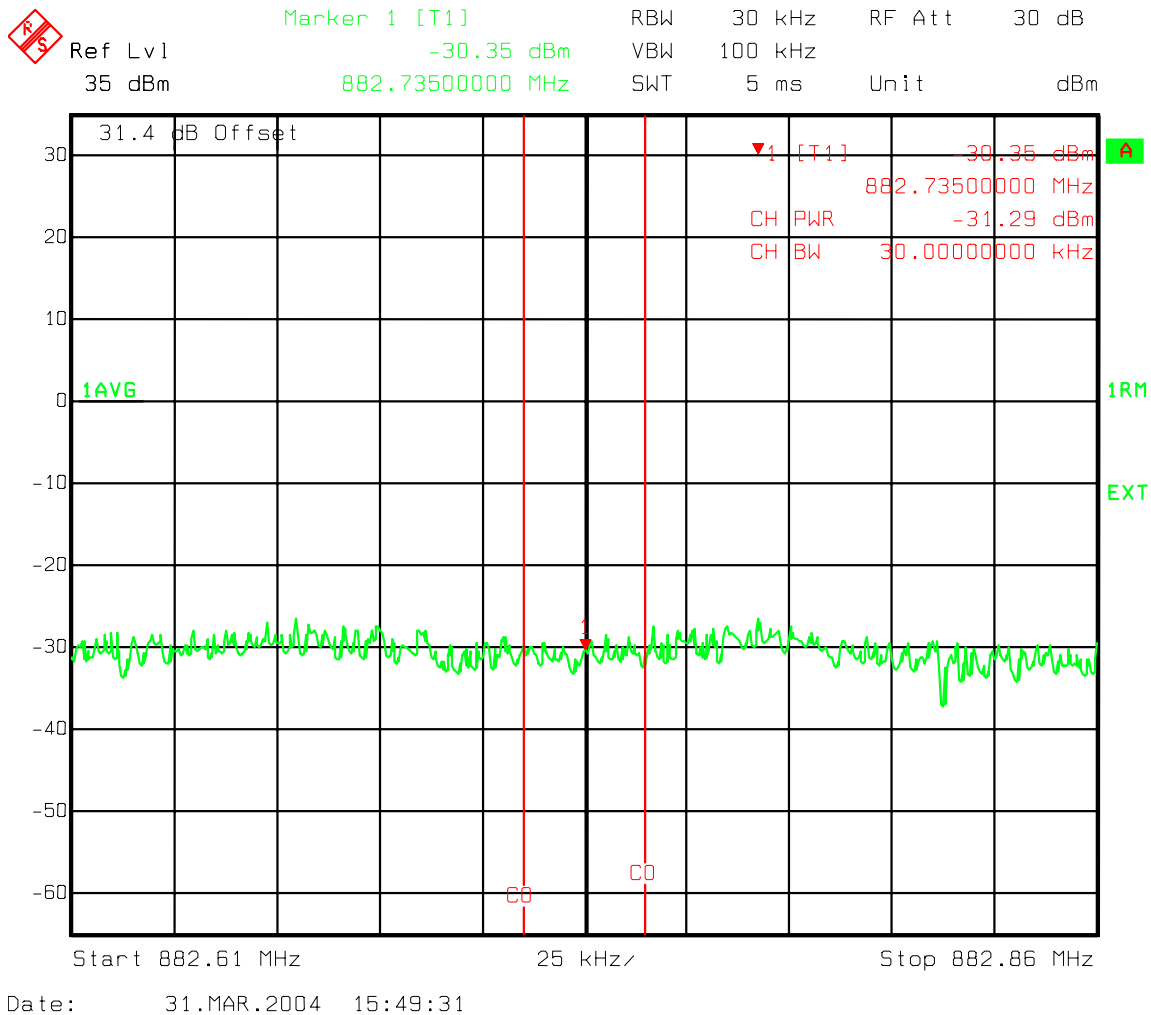

**Figure 80 : One Carrier - Industry Canada 1.98 MHz offset Upper 30 kHz Chan Power Ch 358**

**Single Chan 358 and 642 Spurious Emissions at the 800 MHz MFRM1 Maple Ant.  
Port one Carrier Band B IS 856**

**B Band IS856 Spurious emissions 10kHz-400 MHz**

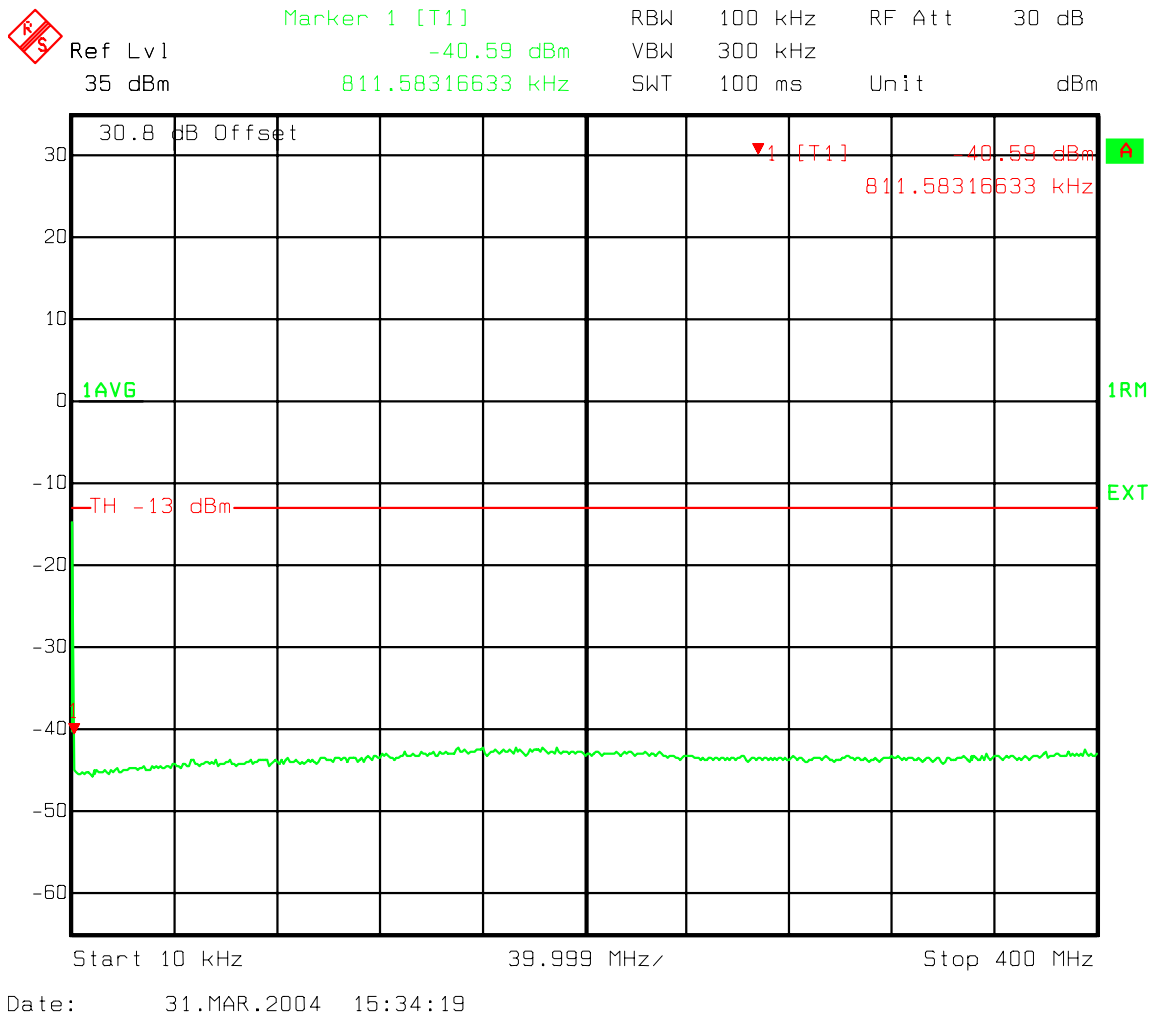

**Figure 81 : One Carrier - B Band IS856 Spurious emissions 10kHz-400 MHz**

### Single Chan 358 and 642 Spurious Emissions at the 800 MHz MFRM1 Maple Ant. Port one Carrier Band B IS 856

#### B Band IS856 Spurious emissions 400MHz to Lower 1MHz Band Edge

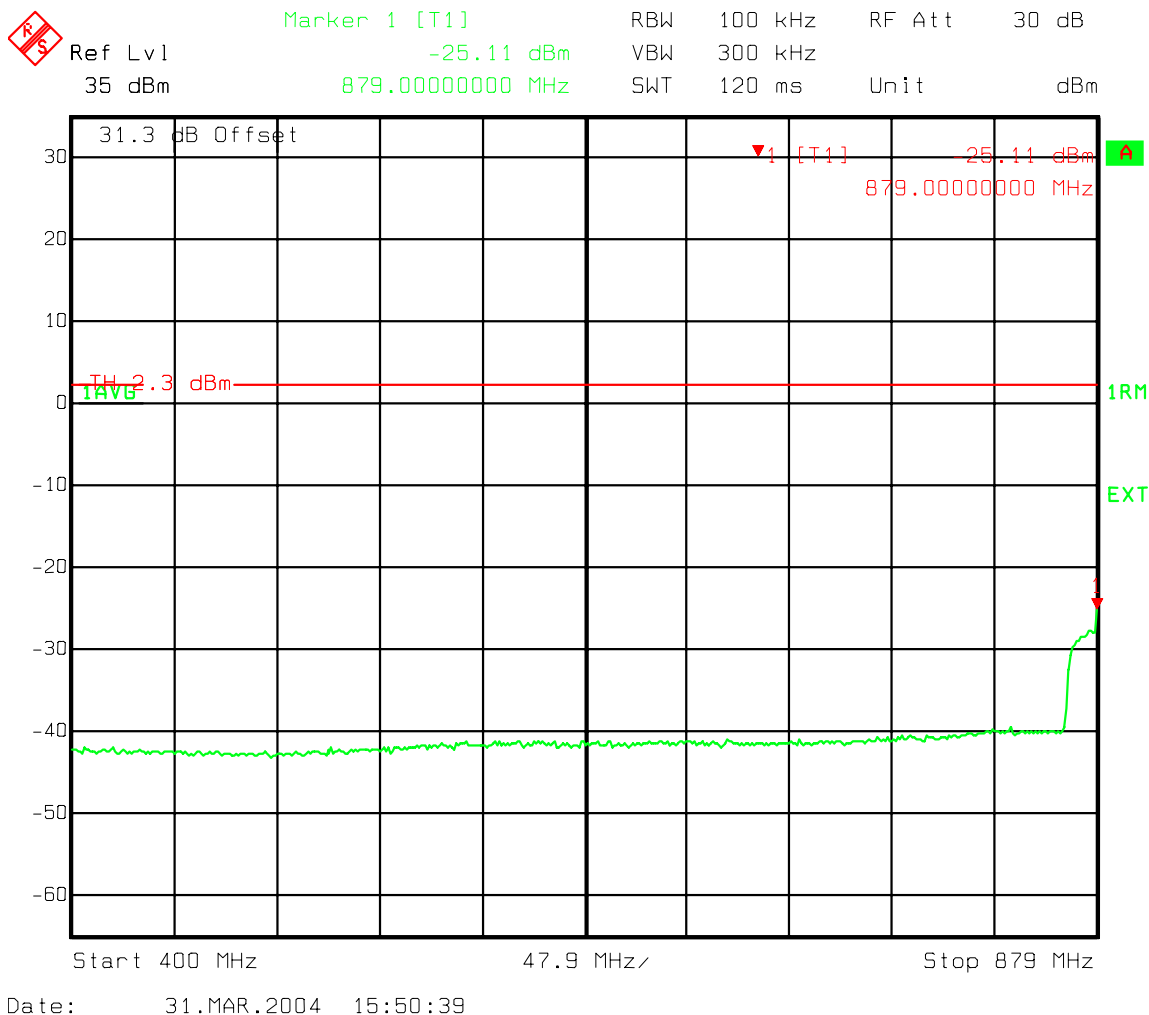

**Figure 82 : One Carrier - B Band IS856 Spurious emissions 400 MHz to Lower 1 MHz Band Edge**

**Single Chan 358 and 642 Spurious Emissions at the 800 MHz MFRM1 Maple Ant.  
 Port one Carrier Band B IS 856**

**B Band IS856 Spurious emissions Upper 1MHz Band Edge to 1GHz**

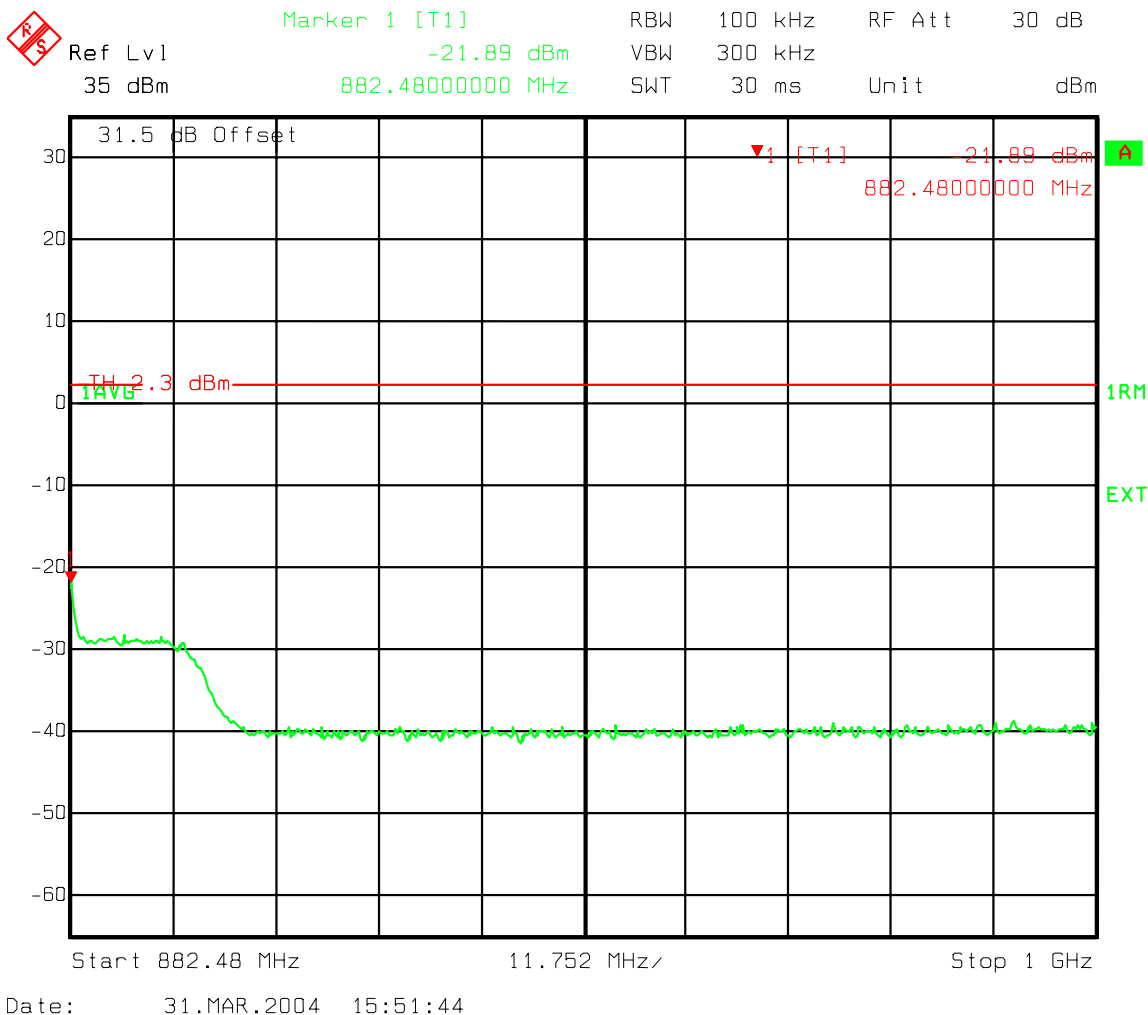

**Figure 83 : One Carrier - B Band IS856 Spurious emissions Upper 1 MHz Band Edge to 1 GHz**

**Single Chan 358 and 642 Spurious Emissions at the 800 MHz MFRM1 Maple Ant.  
 Port one Carrier Band B IS 856**

**B Band IS856 Spurious emissions 400-1000 MHz**

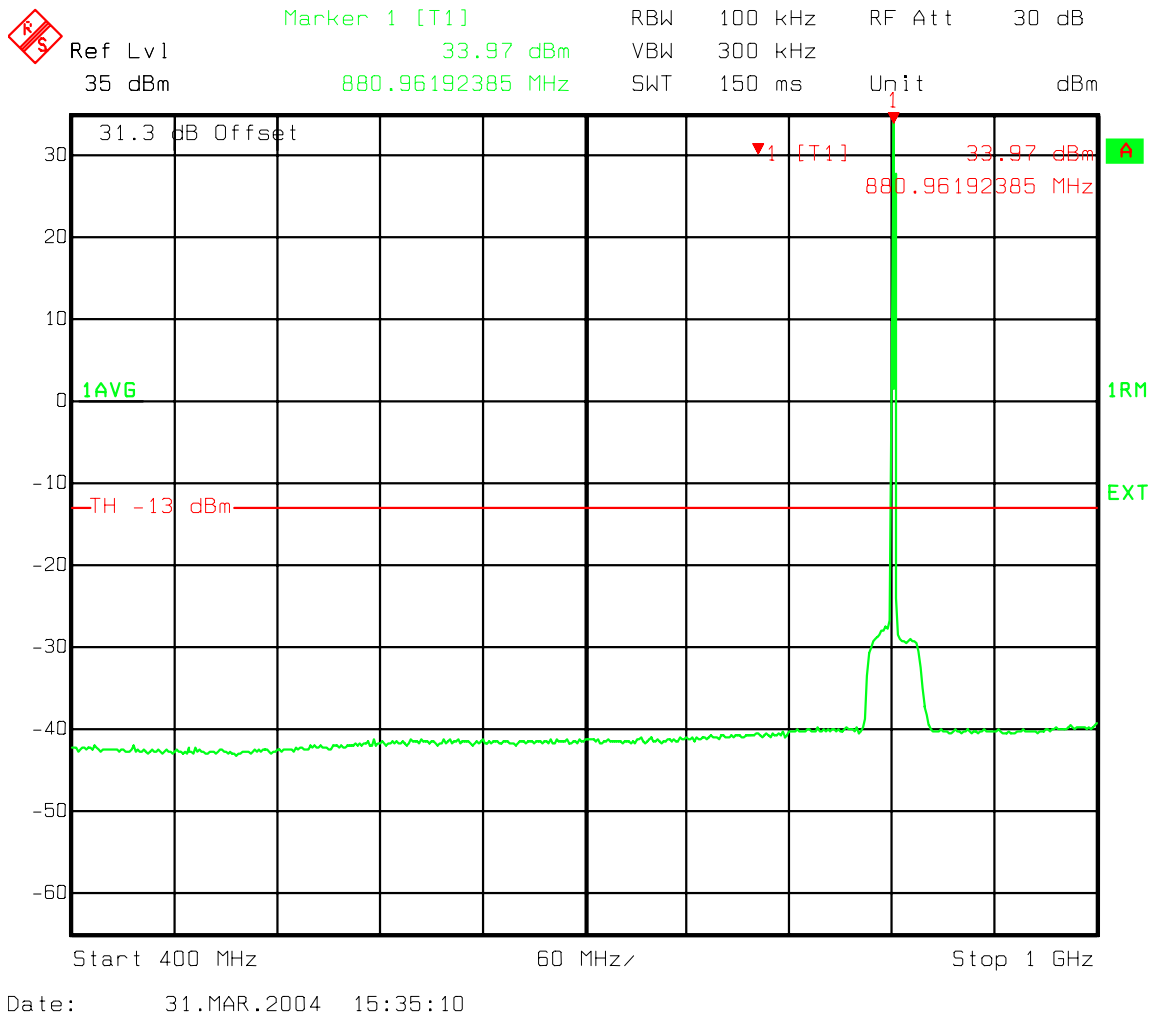

**Figure 84 : One Carrier - B Band IS856 Spurious emissions 400-1000 MHz**

**Single Chan 358 and 642 Spurious Emissions at the 800 MHz MFRM1 Maple Ant.  
Port one Carrier Band B IS 856**

**B Band IS856 Spurious emissions 1000-2000 MHz**

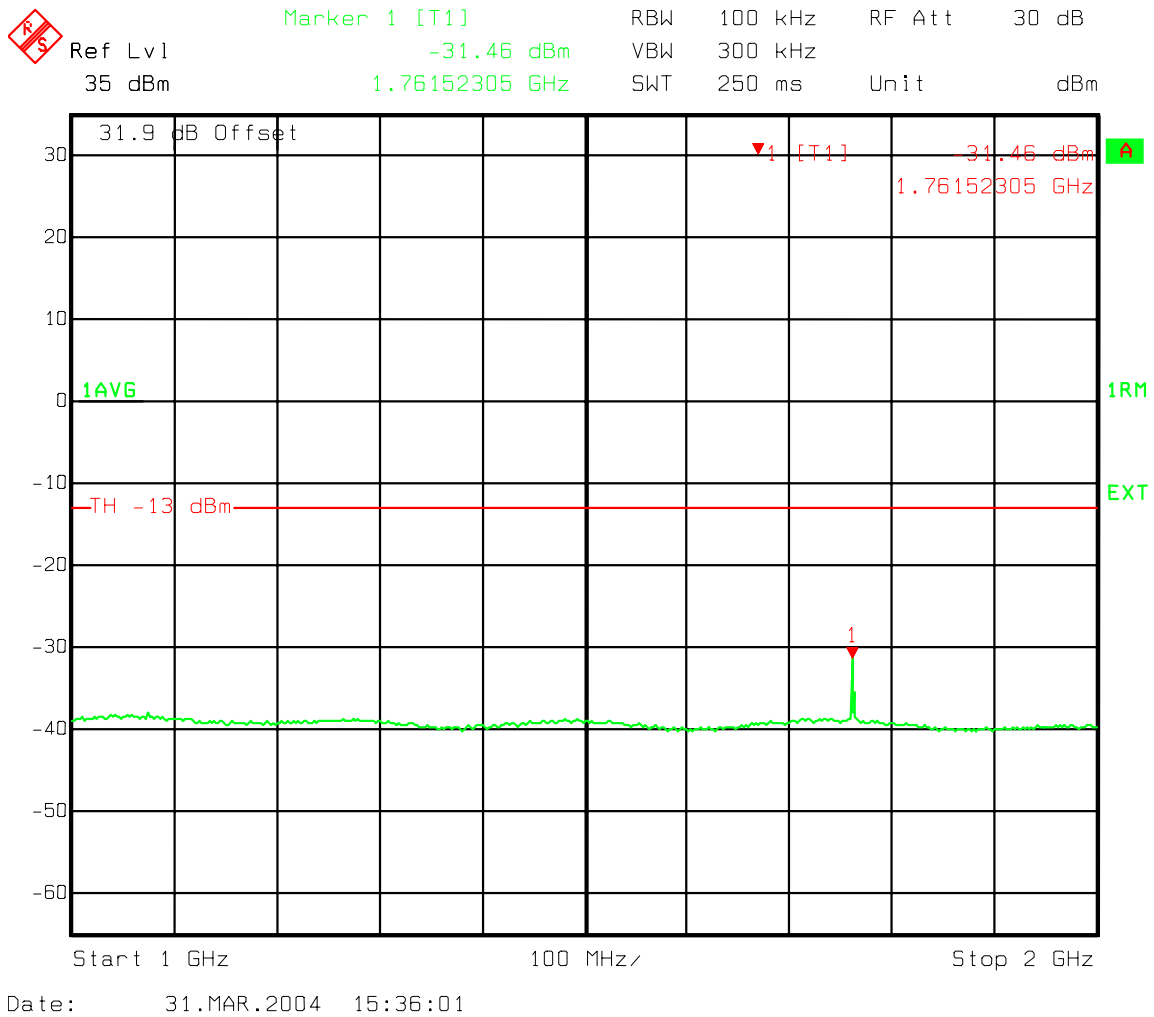

**Figure 85 : One Carrier -B Band IS856 Spurious emissions 1000-2000 MHz**

**Single Chan 358 and 642 Spurious Emissions at the 800 MHz MFRM1 Maple Ant.  
 Port one Carrier Band B IS 856**

**B Band IS856 Spurious emissions 2000-3000 MHz**

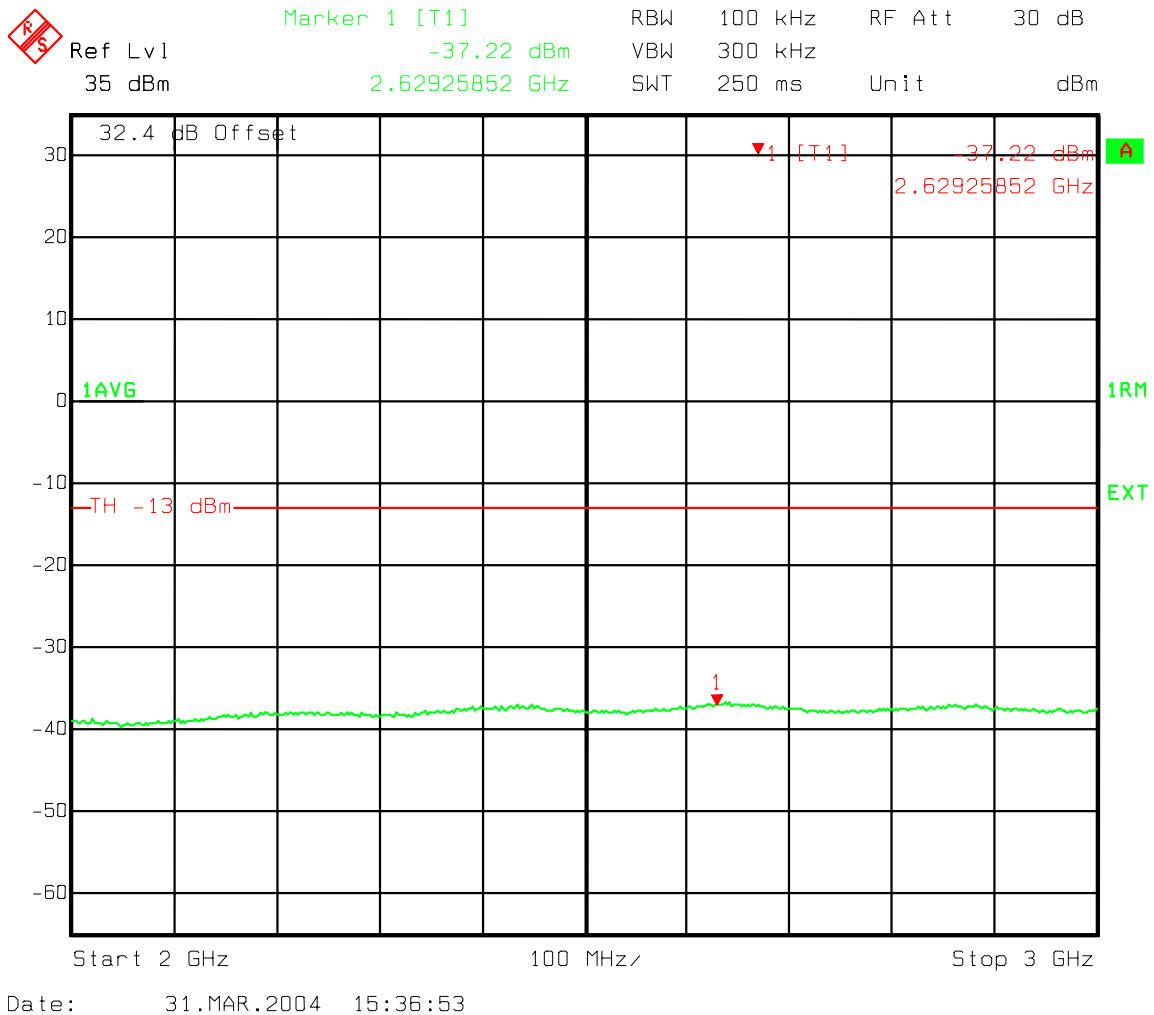
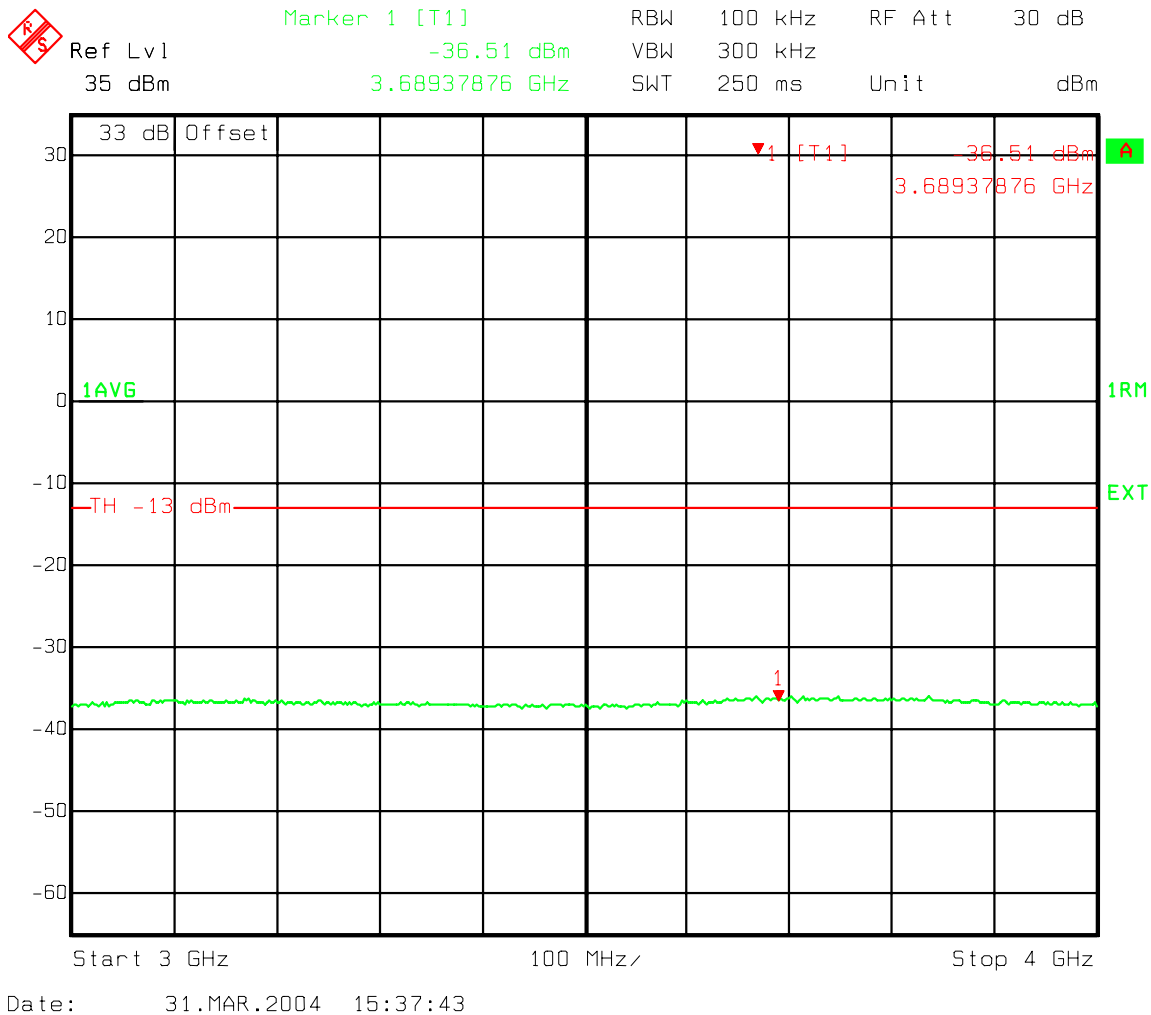

**Figure 86 : One Carrier - B Band IS856 Spurious emissions 2000-3000 MHz**



**Single Chan 358 and 642 Spurious Emissions at the 800 MHz MFRM1 Maple Ant.  
Port one Carrier Band B IS 856**

**B Band IS856 Spurious emissions 3000-4000 MHz**



**Figure 87 : One Carrier - B Band IS856 Spurious emissions 3000-4000 MHz**

**Single Chan 358 and 642 Spurious Emissions at the 800 MHz MFRM1 Maple Ant.  
 Port one Carrier Band B IS 856**

**B Band IS856 Spurious emissions 4000-5000 MHz**

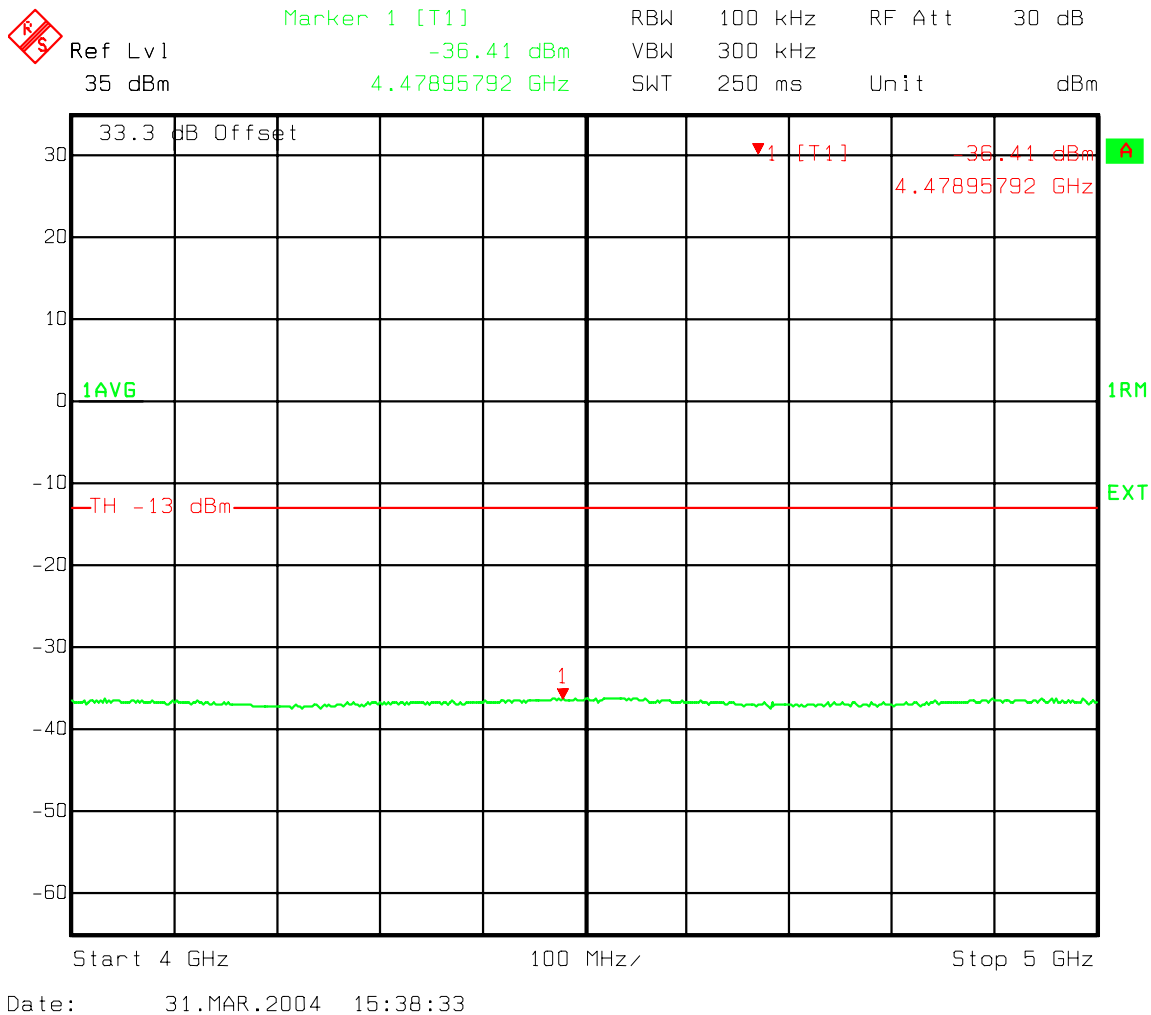

**Figure 88 : One Carrier - B Band IS856 Spurious emissions 4000-5000 MHz**

**Single Chan 358 and 642 Spurious Emissions at the 800 MHz MFRM1 Maple Ant.  
Port one Carrier Band B IS 856**

**B Band IS856 Spurious emissions 5000-6000 MHz**

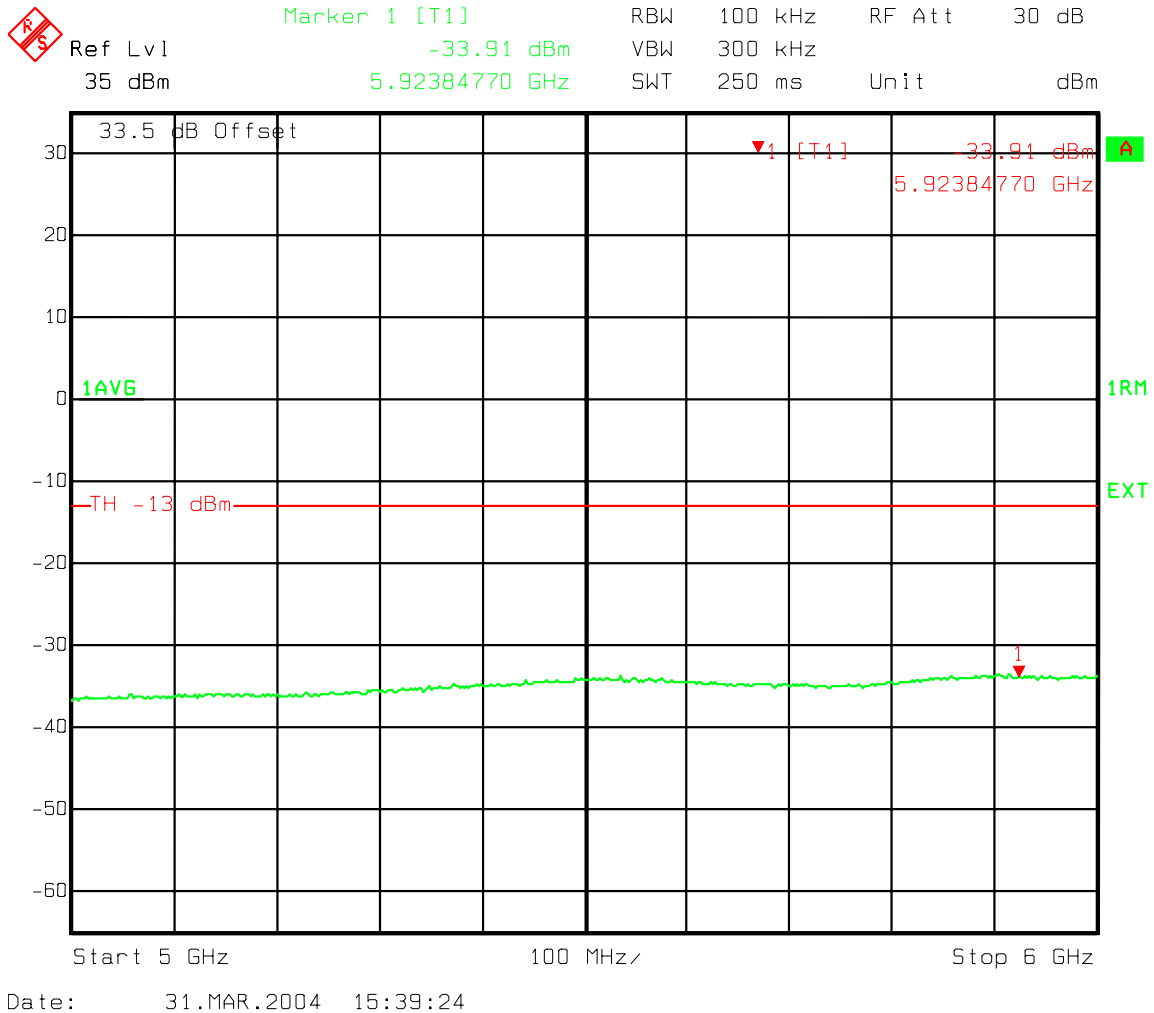

**Figure 89 : One Carrier - B Band IS856 Spurious emissions 5000-6000 MHz**

### Single Chan 358 and 642 Spurious Emissions at the 800 MHz MFRM1 Maple Ant. Port one Carrier Band B IS 856

#### B Band IS856 Spurious emissions 6000-7000 MHz

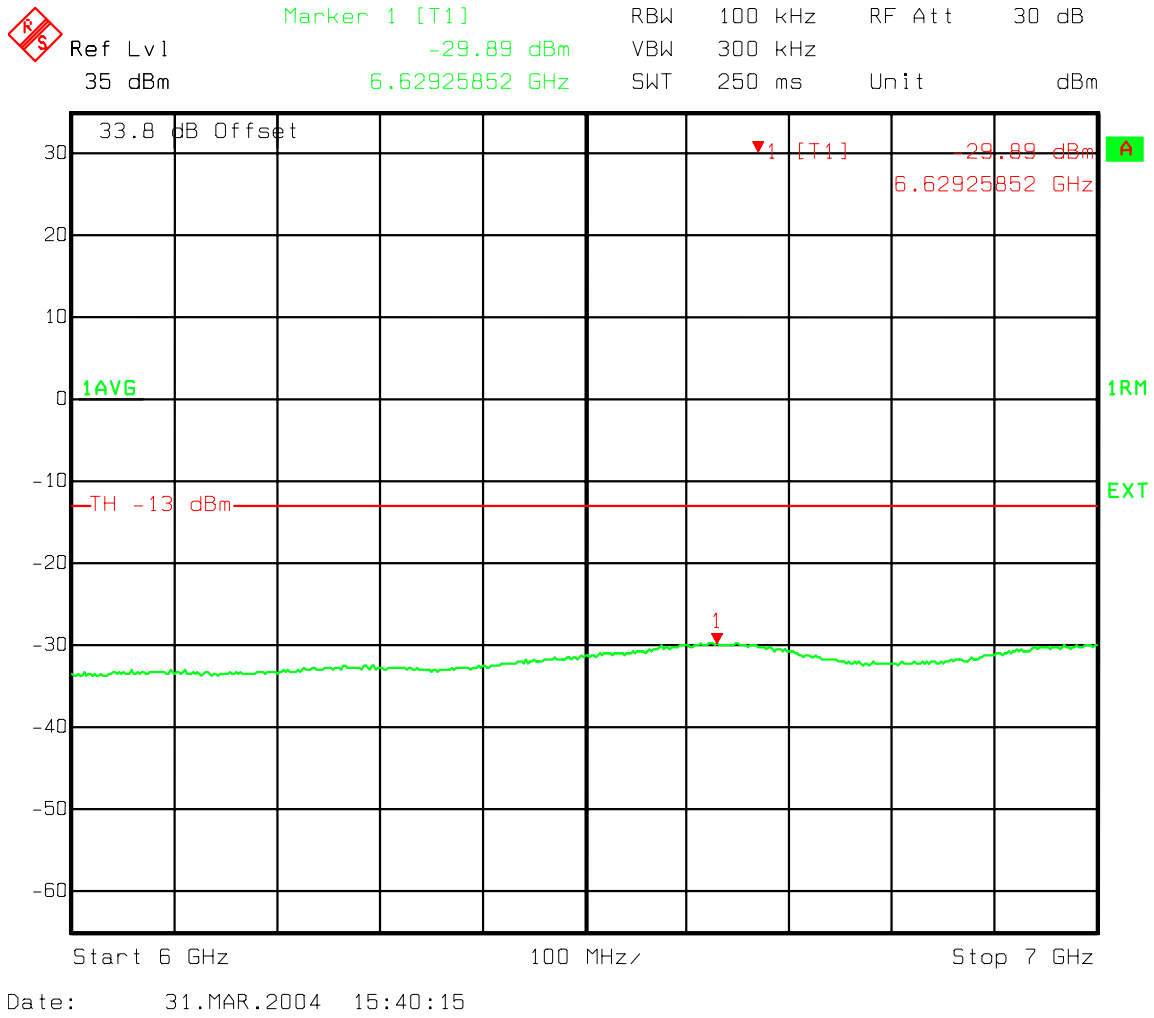

**Figure 90 : One Carrier - B Band IS856 Spurious emissions 6000-7000 MHz**

**Single Chan 358 and 642 Spurious Emissions at the 800 MHz MFRM1 Maple Ant.  
Port one Carrier Band B IS 856**

**B Band IS856 Spurious emissions 7000-8000 MHz**

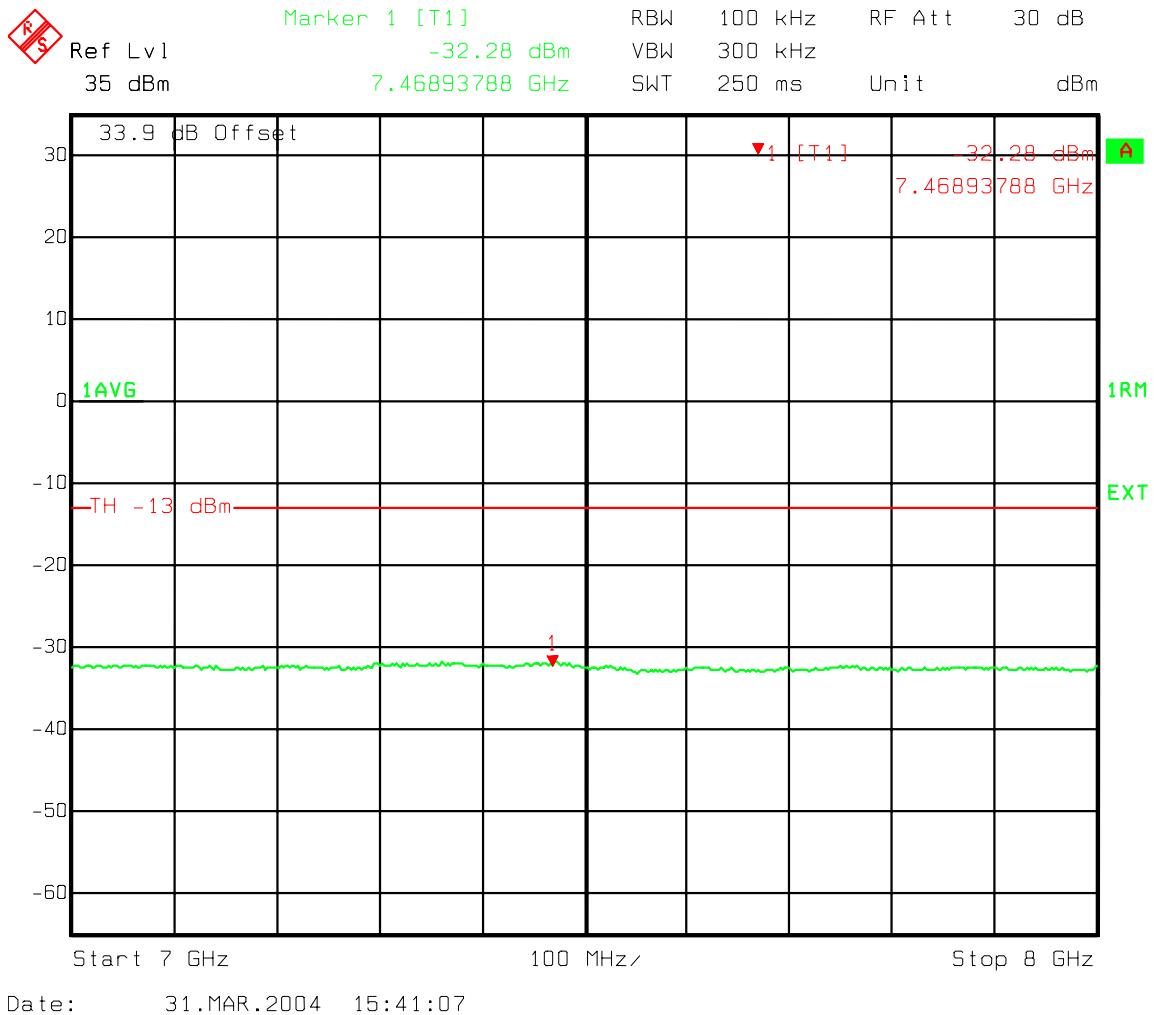

**Figure 91 : One Carrier - B Band IS856 Spurious emissions 7000-8000 MHz**

**Single Chan 358 and 642 Spurious Emissions at the 800 MHz MFRM1 Maple Ant.  
 Port one Carrier Band B IS 856**

**B Band IS856 Spurious emissions 8000-9000 MHz**

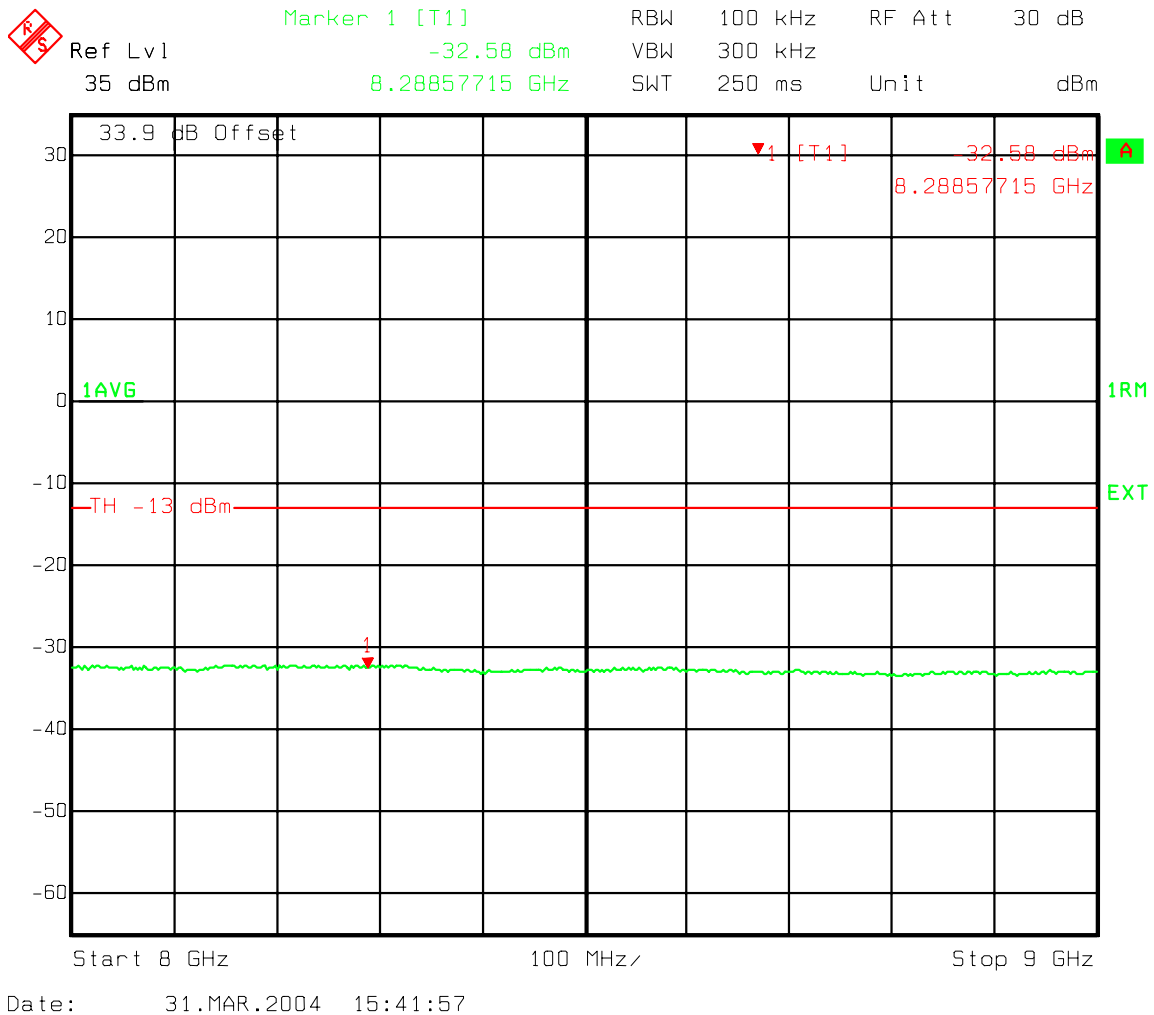

**Figure 92 : One Carrier - B Band IS856 Spurious emissions 8000-9000 MHz**

**Single Chan 358 and 642 Spurious Emissions at the 800 MHz MFRM1 Maple Ant.  
 Port one Carrier Band B IS 856**

**B Band IS856 Spurious emissions 9000-10000 MHz**

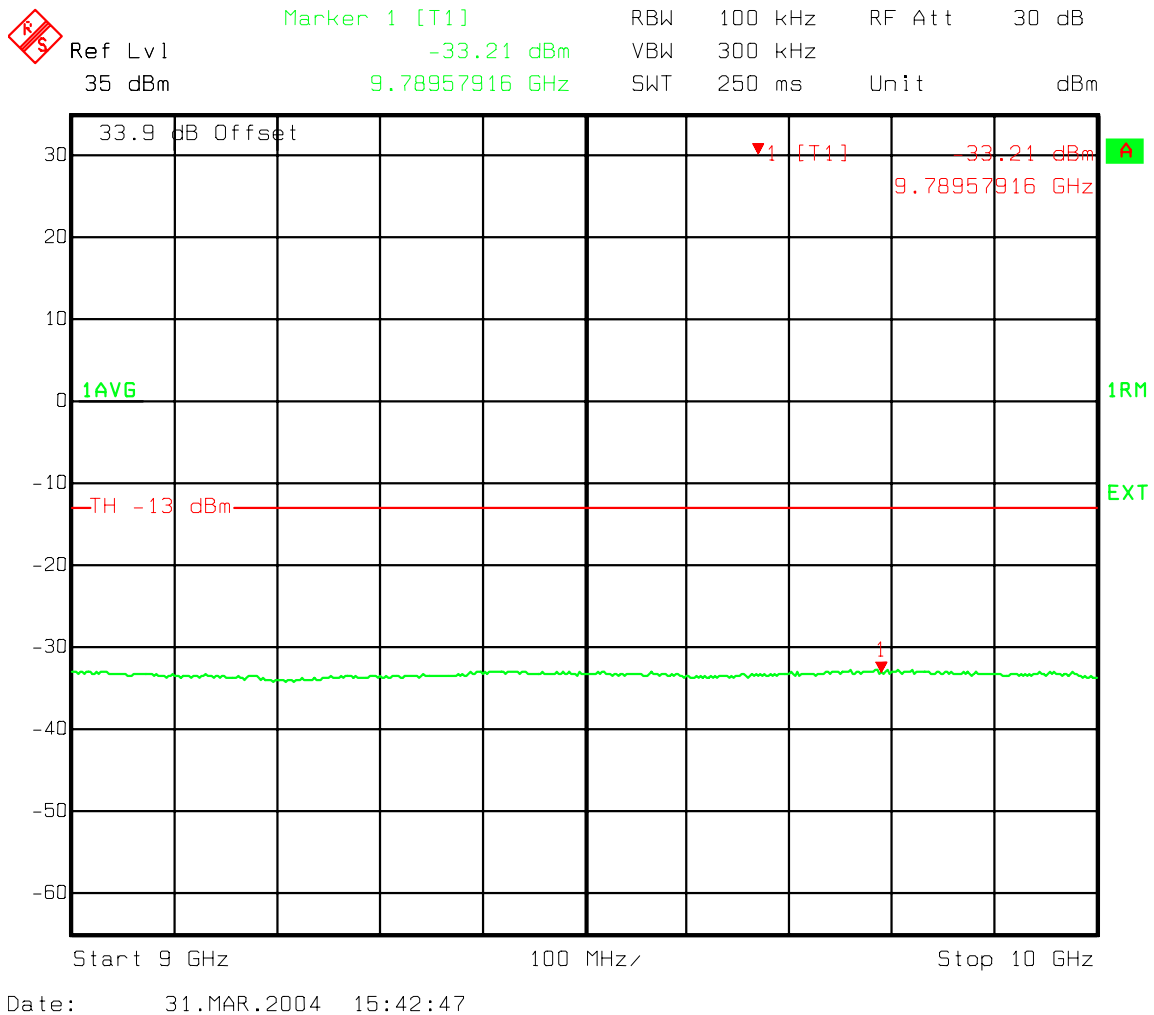
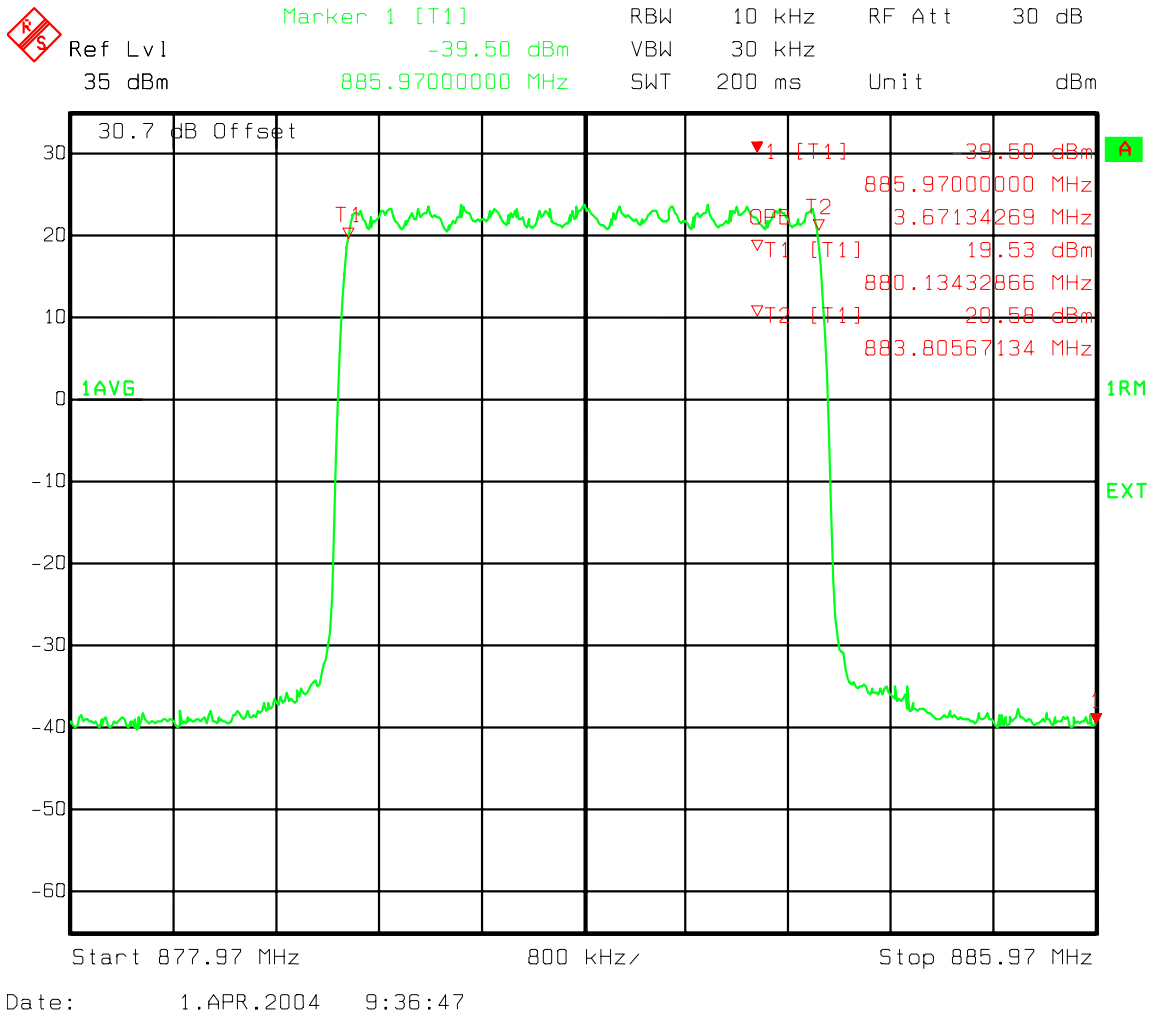

**Figure 93 : One Carrier - B Band IS856 Spurious emissions 9000-10000 MHz**

## 9 Appendix E - Three Carriers IS-856 16 QAM Spurious Emission

**Three Channel 358, 399, 440 and 560, 601, 642 Spurious Emissions at the 800 MHz MFRM1 Maple Ant. Port Three Carrier band B IS856**

**Occupied Bandwidth Ch 358, 399, 440 Band B IS856**

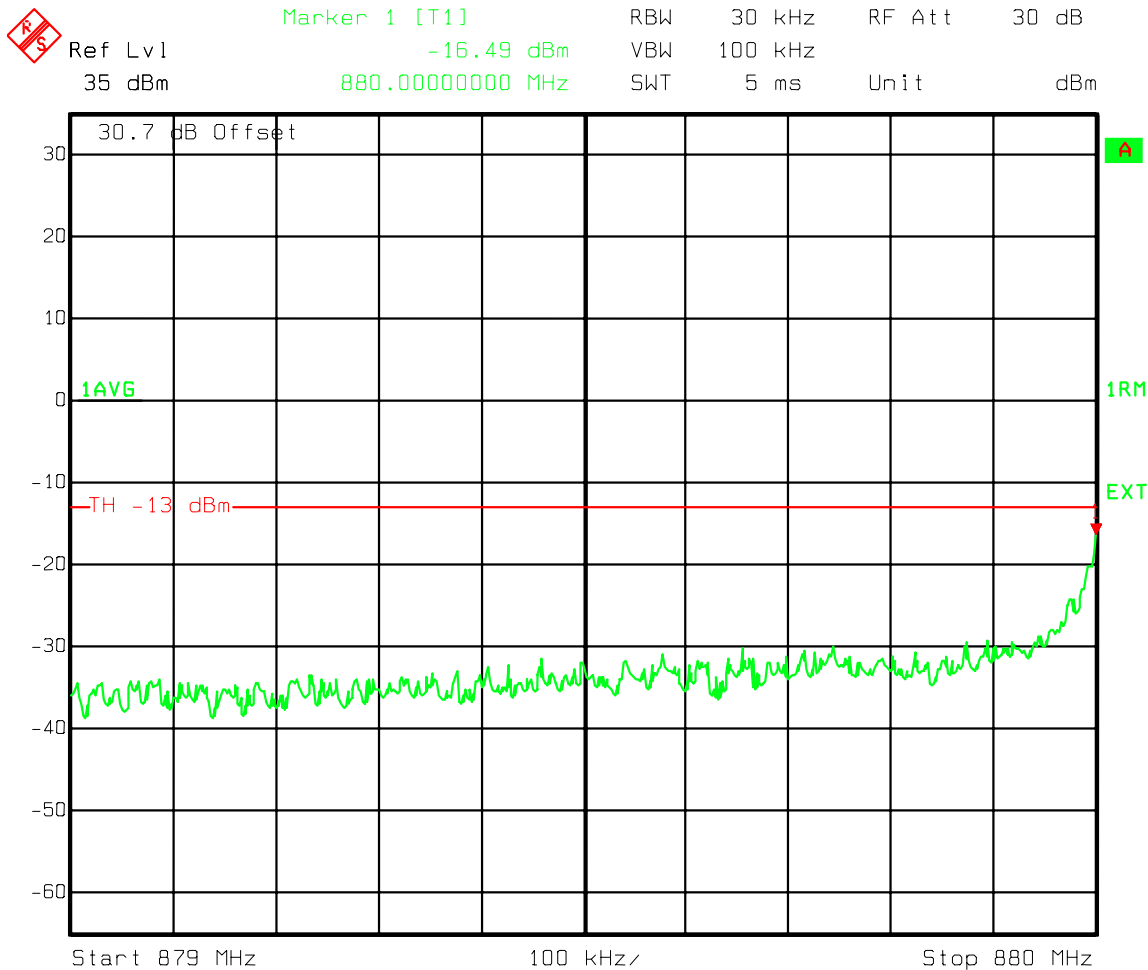

**Figure 94 : Three Carriers - Occupied Bandwidth Ch 358, 399, 440**



**Three Channel 358, 399, 440 and 560, 601, 642 Spurious Emissions at the 800 MHz  
MFRM1 Maple Ant. Port Three Carrier band B IS856**

**B Band Ch 358, 399, 440 IS856 Adjacent 1Mhz Lower emissions 879-880MHz**



Date: 1.APR.2004 9:24:04

**Figure 95 : Three Carriers - B Band Ch 358, 399, 440 IS856 Adjacent 1MHz Lower emissions 879-880MHz**

**Three Channel 358, 399, 440 and 560, 601, 642 Spurious Emissions at the 800 MHz MFRM1 Maple Ant. Port Three Carrier band B IS856**

**B Band Ch358, 399, 440 IS856 Channel power Adjacent 37.5 kHz Lower emissions to 880 MHz**

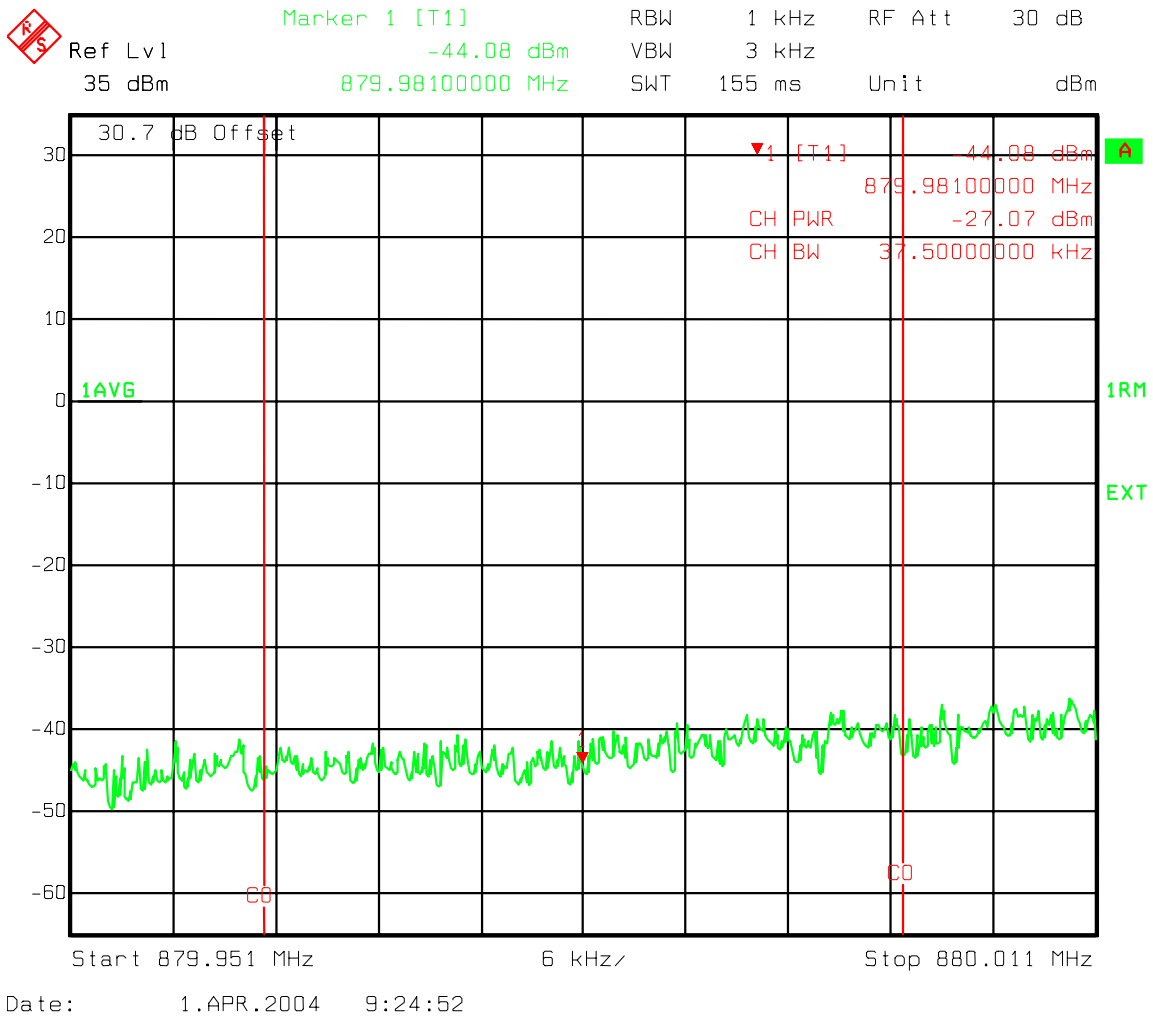

**Figure 96 : Three Carriers - Ch 358, 399, 440 IS856 Lower B Band Adjacent to outside edge 37.5kHz band Channel Power**

**Three Channel 358, 399, 440 and 560, 601, 642 Spurious Emissions at the 800 MHz  
MFRM1 Maple Ant. Port Three Carrier band B IS856**

**Ch 560, 601, 642 Upper B Band adjacent 1MHz band emissions 890-891 MHz**

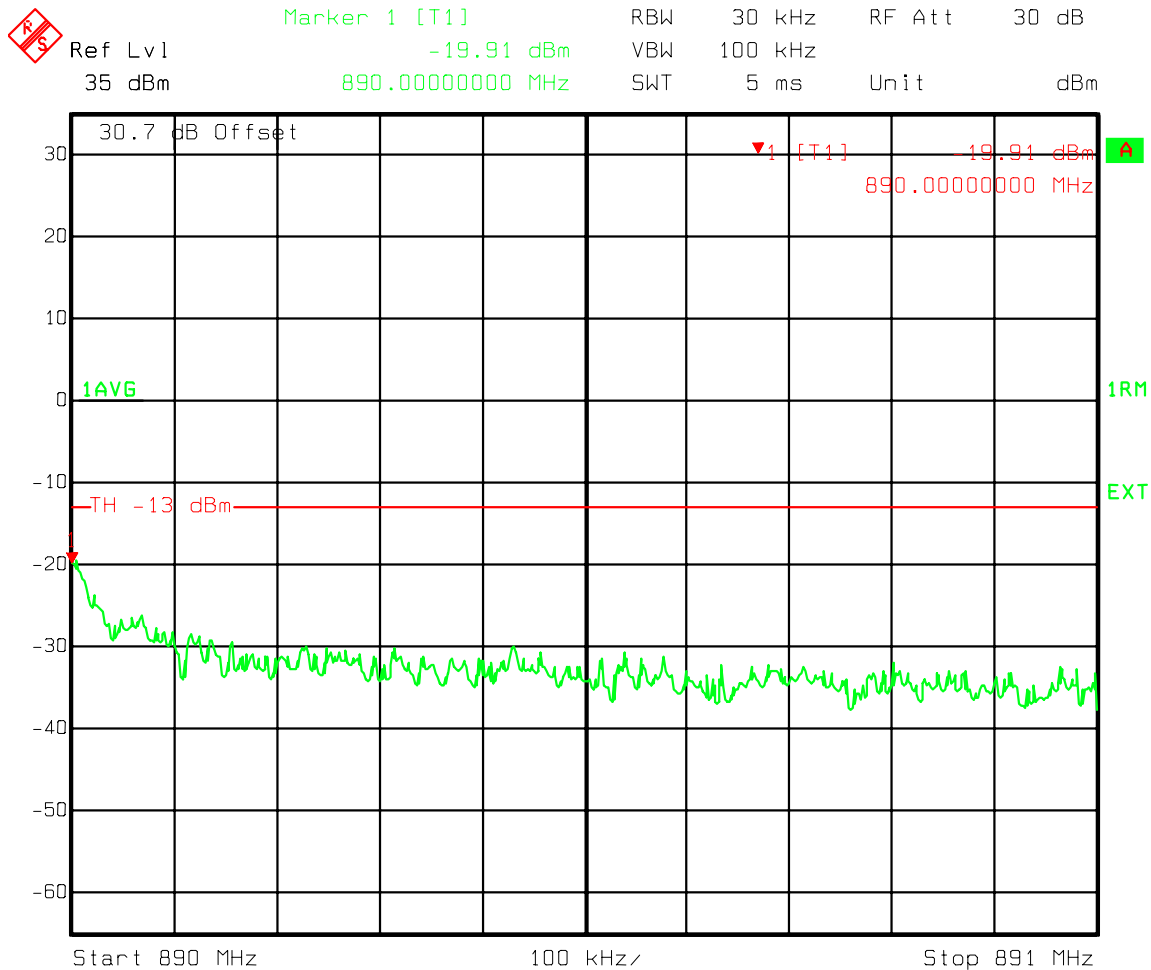

Date: 1.APR.2004 10:37:17

**Figure 97 : Three Carriers - Ch 560, 601, 642 Upper a Band adjacent 1 MHz band emissions 890-891 MHz**

**Three Channel 358, 399, 440 and 560, 601, 642 Spurious Emissions at the 800 MHz MFRM1 Maple Ant. Port Three Carrier band B IS856**

**Ch 560, 601, 642 Upper B Band adjacent to outside edge 37.5 kHz band Channel power**

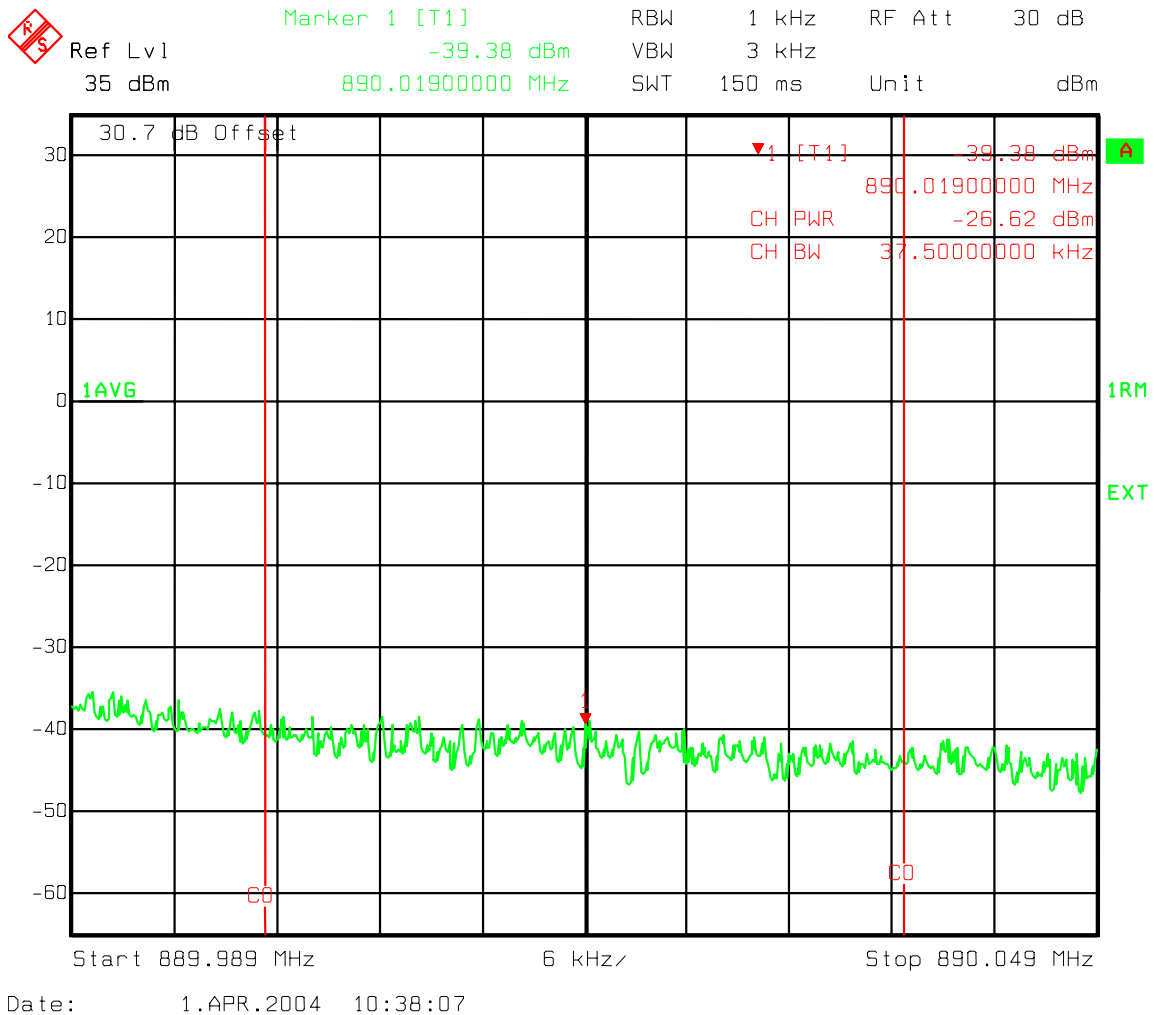

**Figure 98 : Three Carriers - Ch 560, 601, 642 Upper B Band adjacent to outside edge 37.5 kHz band Channel power**

**Three Channel 358, 399, 440 and 560, 601, 642 Spurious Emissions at the 800 MHz  
MFRM1 Maple Ant. Port Three Carrier band B IS856**

**Industry Canada Lower 750 kHz offset 30kHz Chan Power Ch 358, 399, 440**

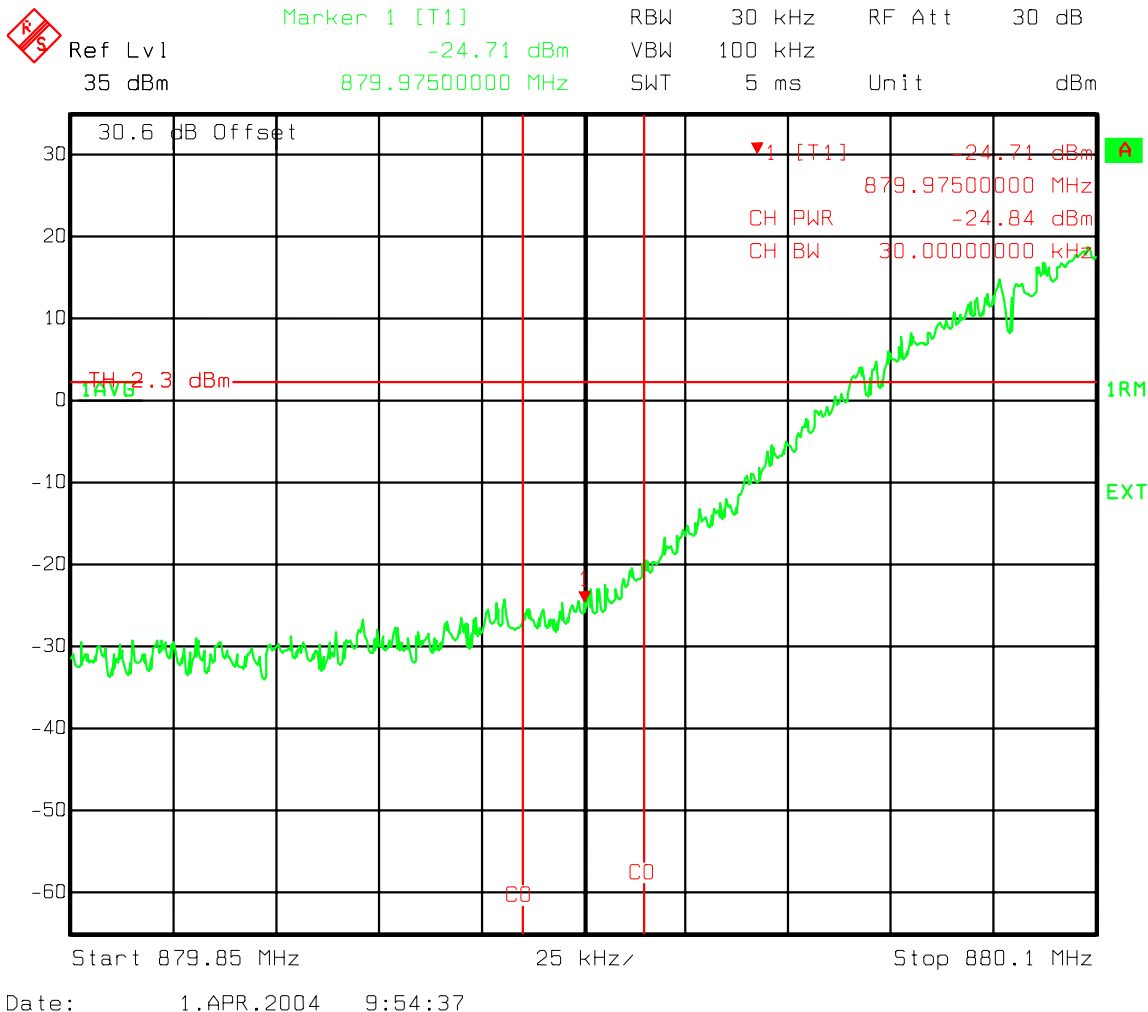

**Figure 99 : Three Carriers - Industry Canada Lower 750 kHz offset 30 kHz Chan Power  
Ch 358, 399, 440**

**Three Channel 358, 399, 440 and 560, 601, 642 Spurious Emissions at the 800 MHz  
 MFRM1 Maple Ant. Port Three Carrier band B IS856**

**Industry Canada Upper 750 kHz offset 30kHz Chan Power Ch 358, 399, 440**

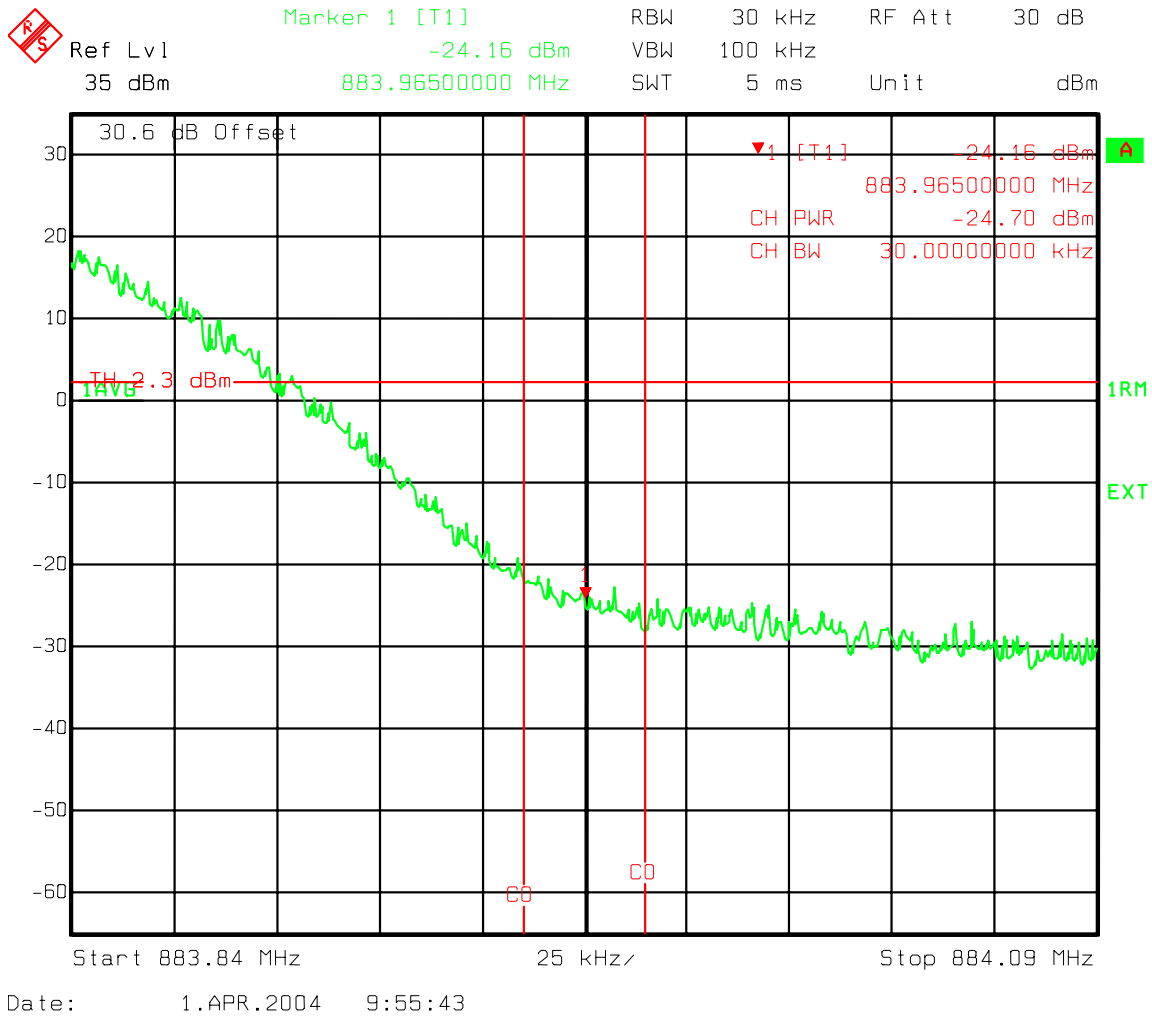

**Figure 100 : Three Carriers - Industry Canada Upper 750 kHz offset 30 kHz Chan Power  
 Ch 358, 399, 440**

**Three Channel 358, 399, 440 and 560, 601, 642 Spurious Emissions at the 800 MHz  
MFRM1 Maple Ant. Port Three Carrier band B IS856**

**Industry Canada 1.98 MHz offset Lower 30kHz Chan Power Ch 358, 399, 440**

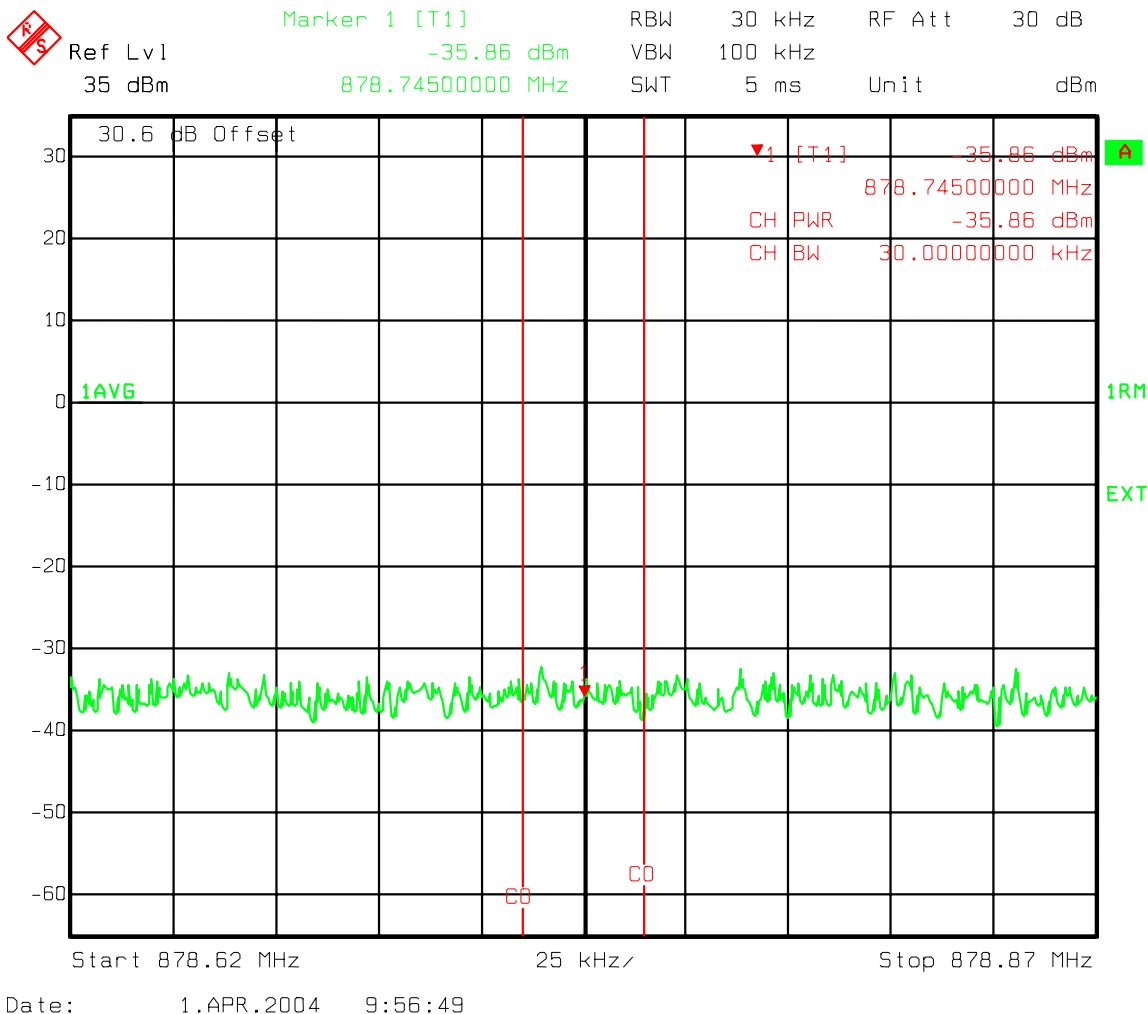

**Figure 101 : Three Carriers - Industry Canada 1.98 MHz offset Lower 30 kHz Chan Power  
Ch 358, 399, 440**

**Three Channel 358, 399, 440 and 560, 601, 642 Spurious Emissions at the 800 MHz  
 MFRM1 Maple Ant. Port Three Carrier band B IS856**

**Industry Canada 1.98 MHz offset Upper 30kHz Chan Power Ch 358, 399, 440**

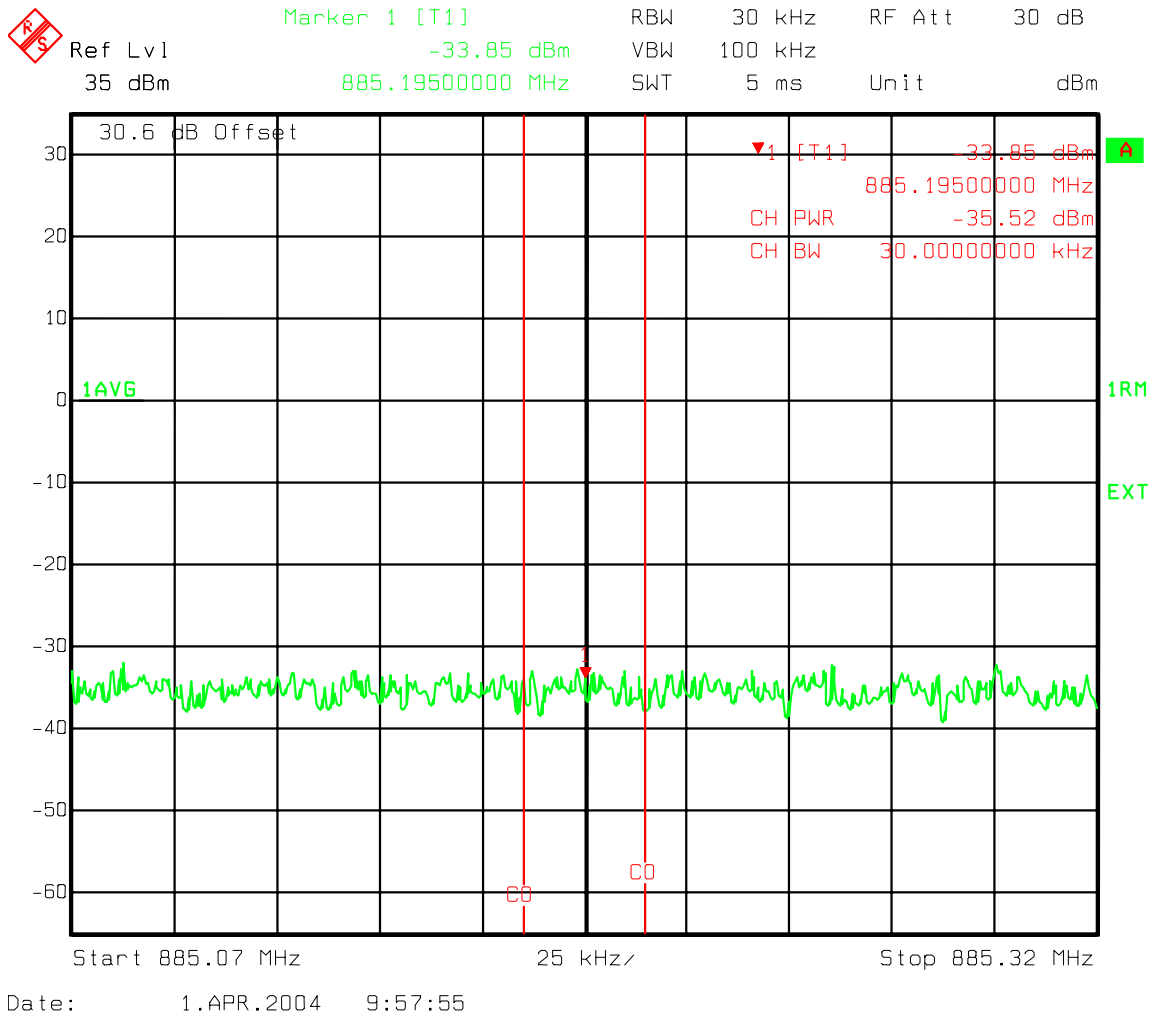
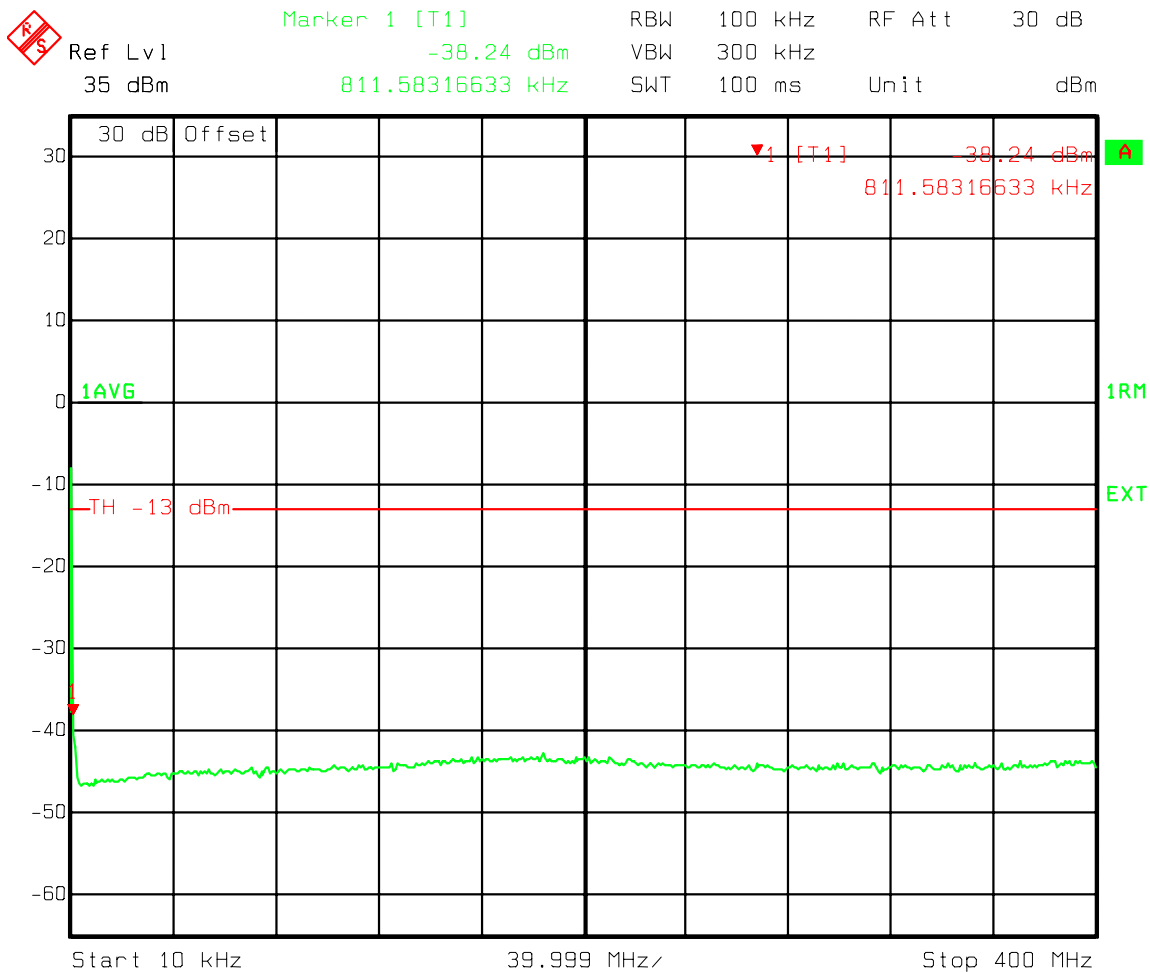

**Figure 102 : Three Carriers - Industry Canada 1.98 MHz offset Upper 30 kHz Chan Power Ch 358, 399, 440**



**Three Channel 358, 399, 440 and 560, 601, 642 Spurious Emissions at the 800 MHz  
MFRM1 Maple Ant. Port Three Carrier band B IS856**

**B Band IS856 Spurious emissions 10kHz-400 MHz**



Date: 1.APR.2004 9:27:26

**Figure 103 : Three Carriers - B Band IS856 Spurious emissions 10kHz-400 MHz**

**Three Channel 358, 399, 440 and 560, 601, 642 Spurious Emissions at the 800 MHz MFRM1 Maple Ant. Port Three Carrier band B IS856**

**B Band IS856 Spurious emissions 400MHz to Lower 1MHz Band Edge**

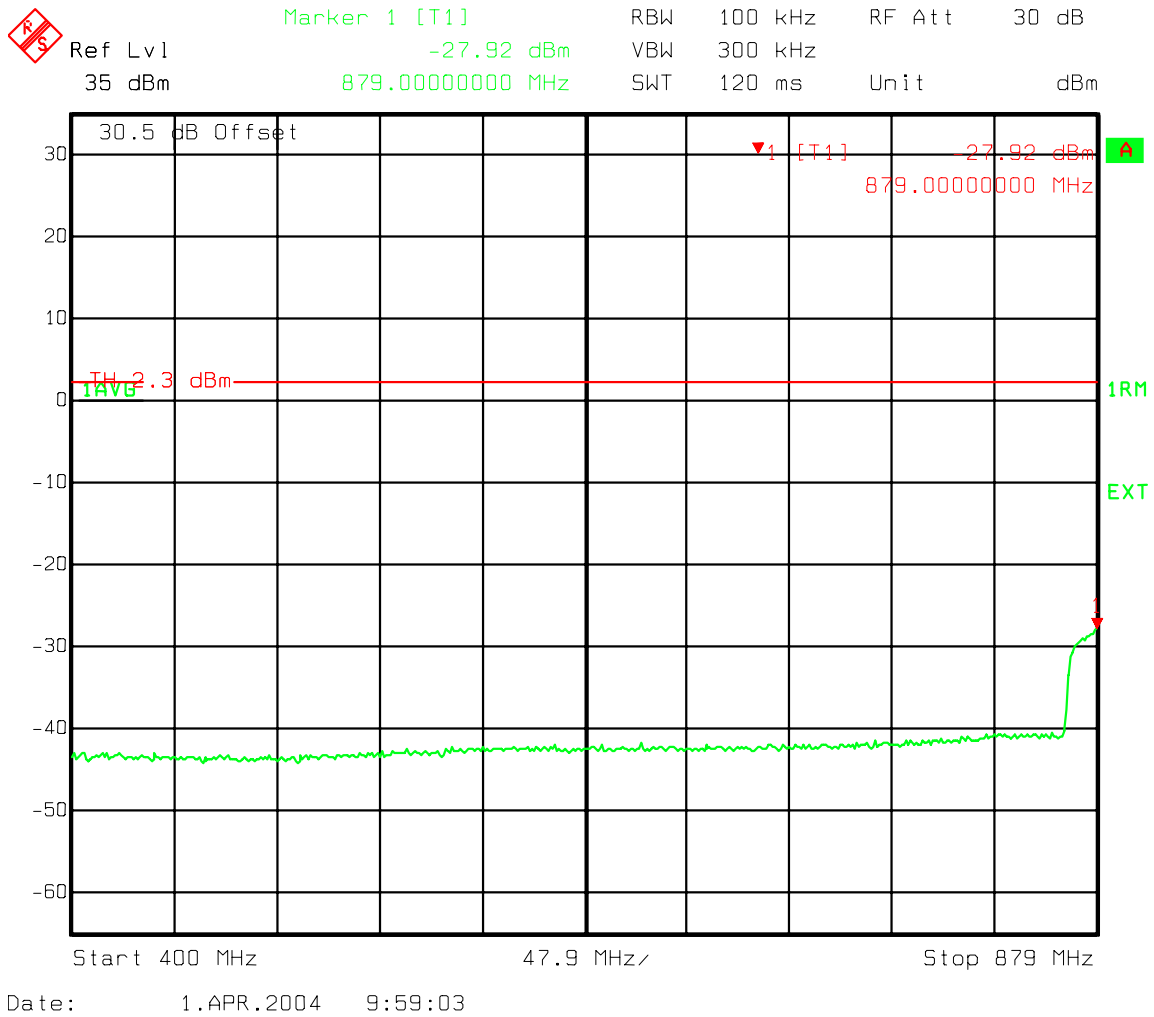

**Figure 104 : Three Carriers - B Band IS856 Spurious emissions 400 MHz to Lower 1 MHz Band Edge**

**Three Channel 358, 399, 440 and 560, 601, 642 Spurious Emissions at the 800 MHz MFRM1 Maple Ant. Port Three Carrier band B IS856**

**B Band IS856 Spurious emissions Upper 1MHz Band Edge to 1GHz**

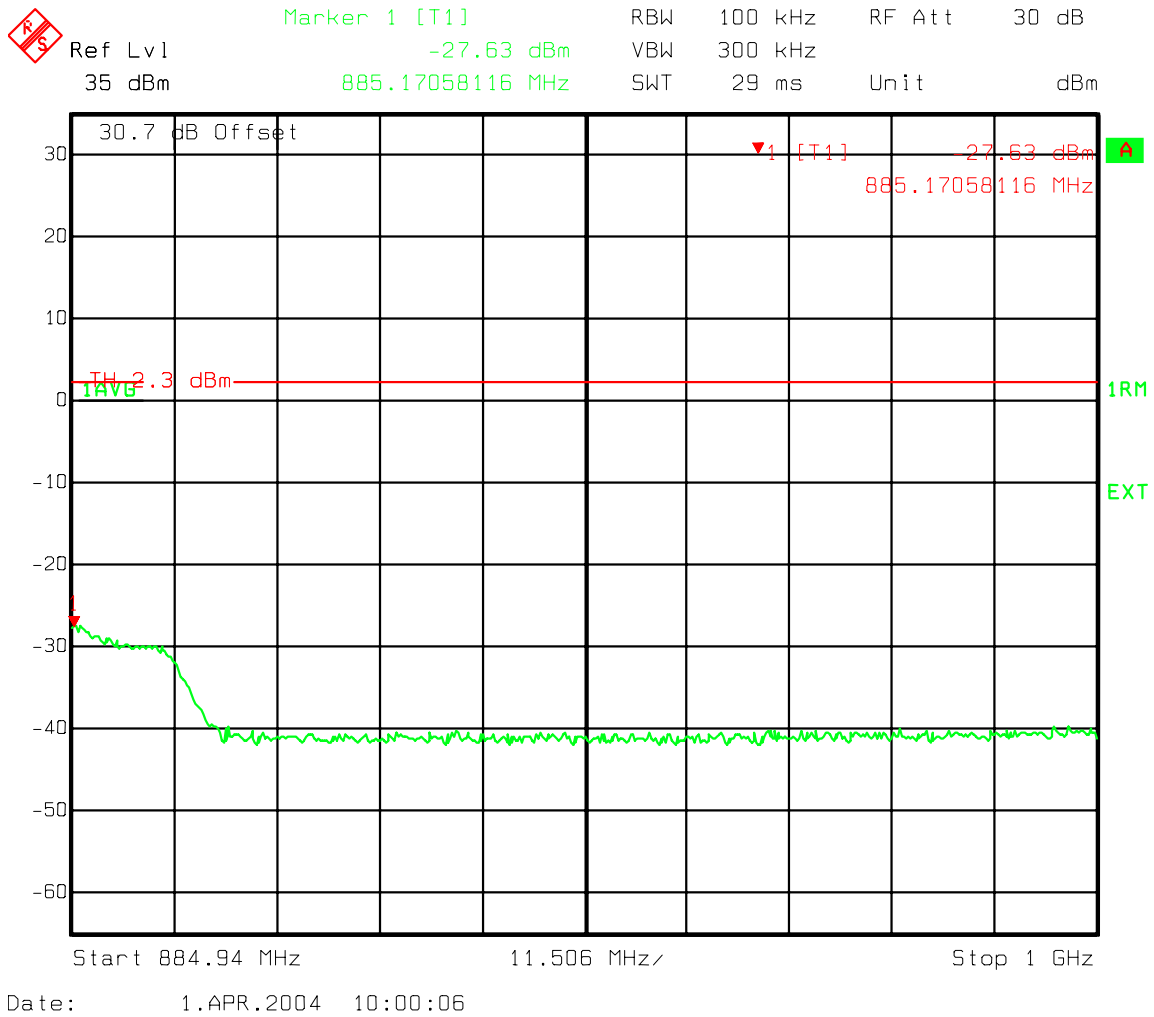

**Figure 105 : Three Carriers - B Band IS856 Spurious emissions Upper 1 MHz Band Edge to 1 GHz**

**Three Channel 358, 399, 440 and 560, 601, 642 Spurious Emissions at the 800 MHz MFRM1 Maple Ant. Port Three Carrier band B IS856**

**B Band IS856 Spurious emissions 400-1000 MHz**

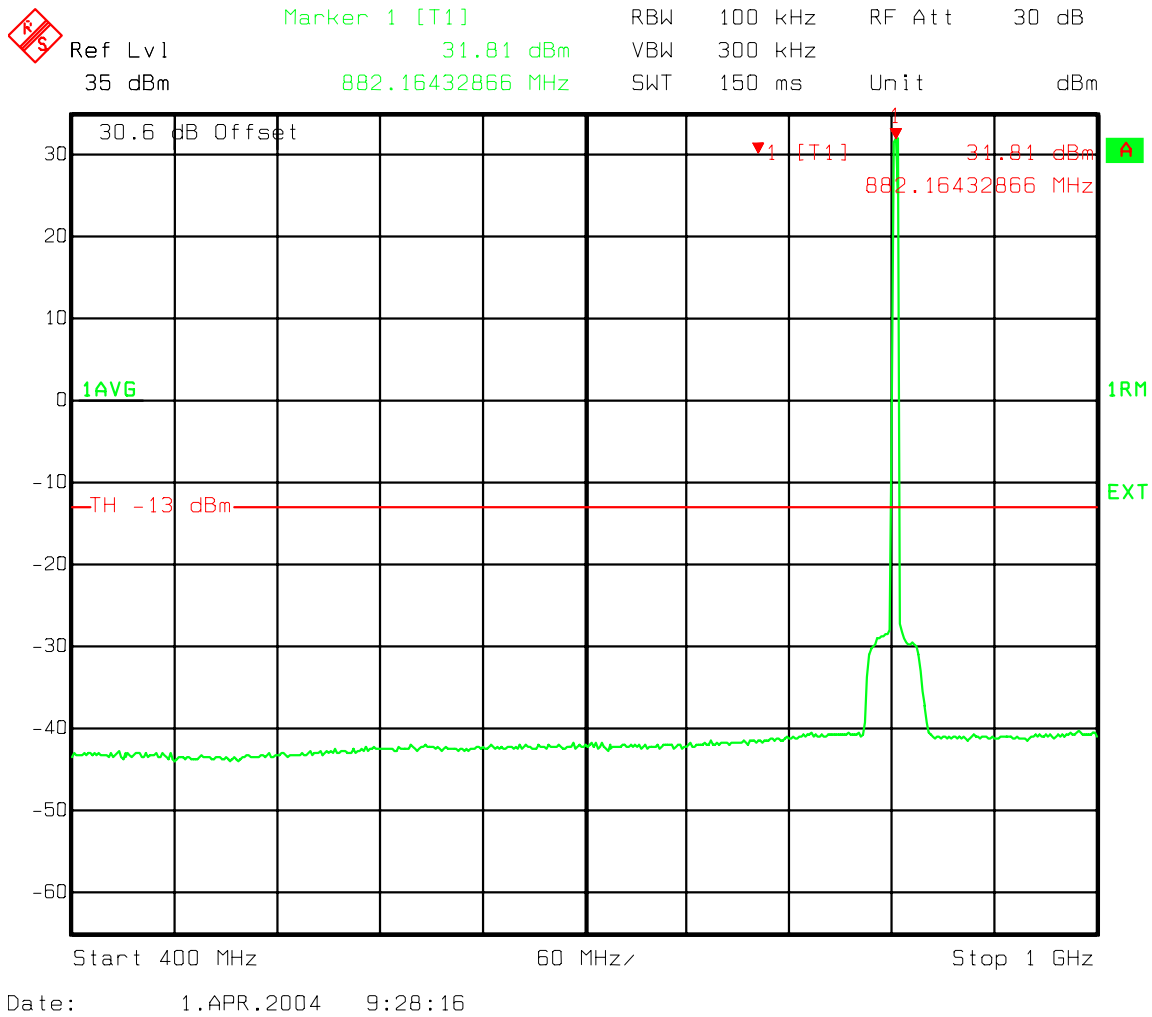

**Figure 106 : Three Carriers - B Band IS856 Spurious emissions 400-1000 MHz**

**Three Channel 358, 399, 440 and 560, 601, 642 Spurious Emissions at the 800 MHz MFRM1 Maple Ant. Port Three Carrier band B IS856**

**B Band IS856 Spurious emissions 1000-2000 MHz**

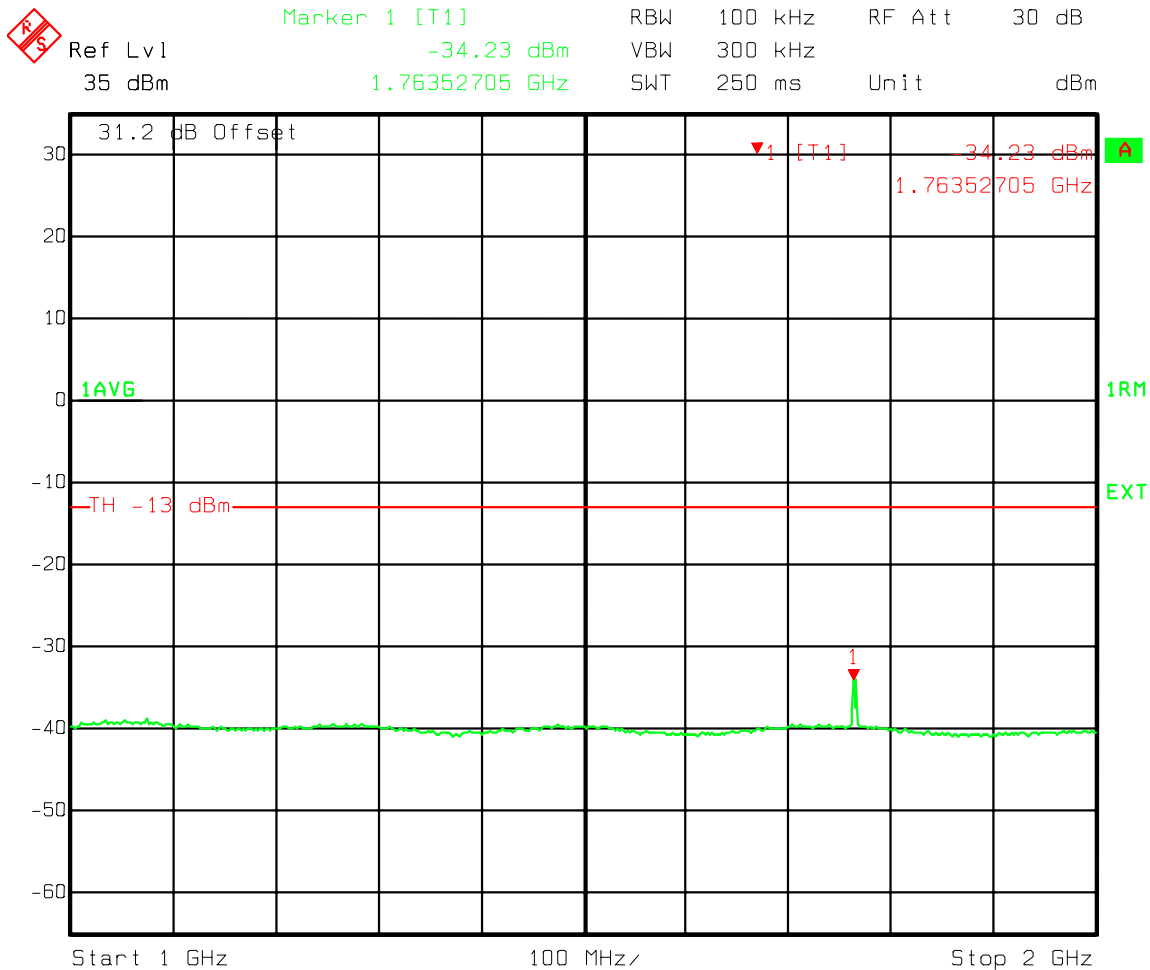

Date: 1.APR.2004 9:29:06

**Figure 107 : Three Carriers - B Band IS856 Spurious emissions 1000-2000 MHz**

**Three Channel 358, 399, 440 and 560, 601, 642 Spurious Emissions at the 800 MHz MFRM1 Maple Ant. Port Three Carrier band B IS856**

**B Band IS856 Spurious emissions 2000-3000 MHz**

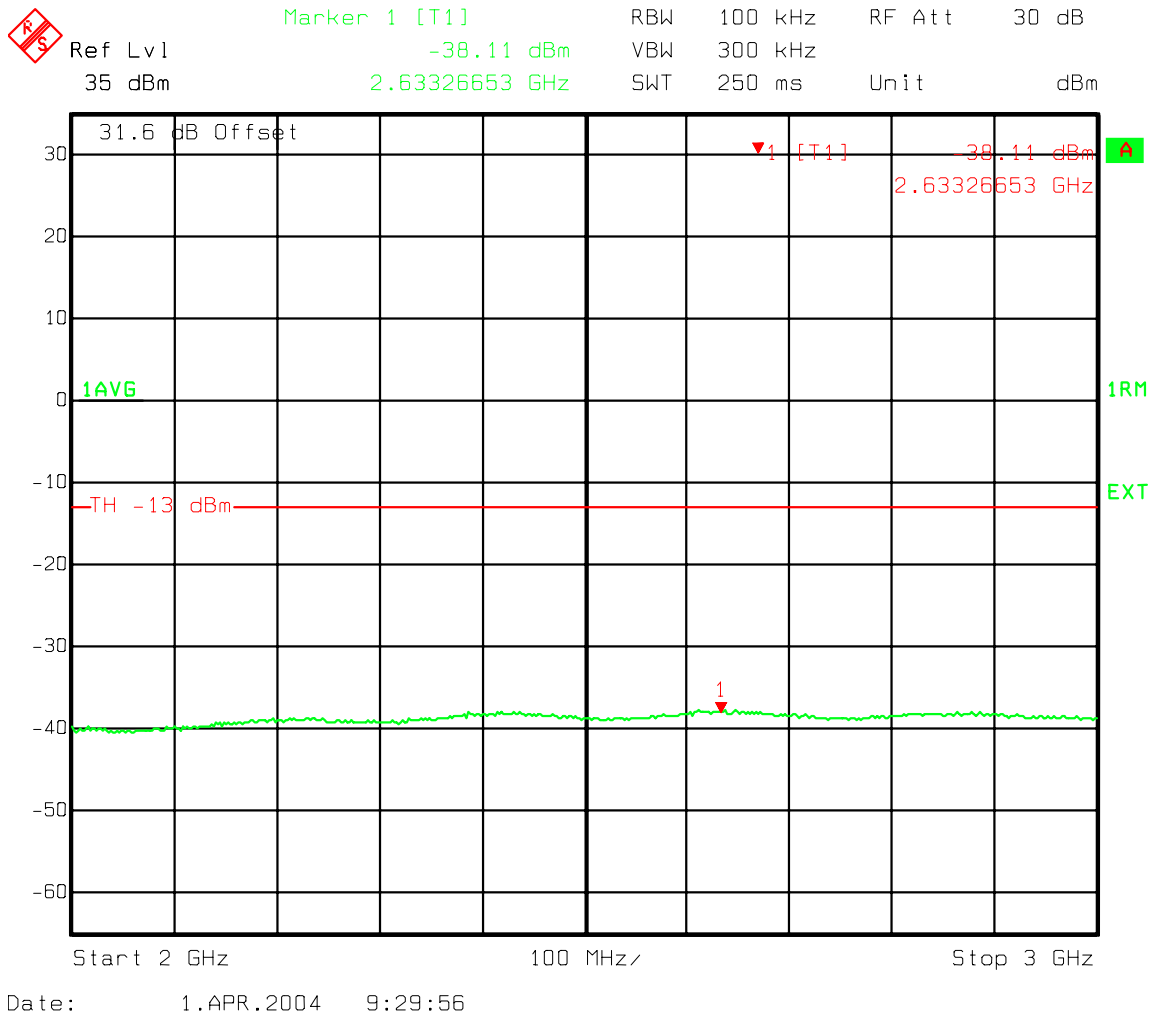

**Figure 108 : Three Carriers - B Band IS856 Spurious emissions 2000-3000 MHz**

**Three Channel 358, 399, 440 and 560, 601, 642 Spurious Emissions at the 800 MHz MFRM1 Maple Ant. Port Three Carrier band B IS856**

**B Band IS856 Spurious emissions 3000-4000 MHz**

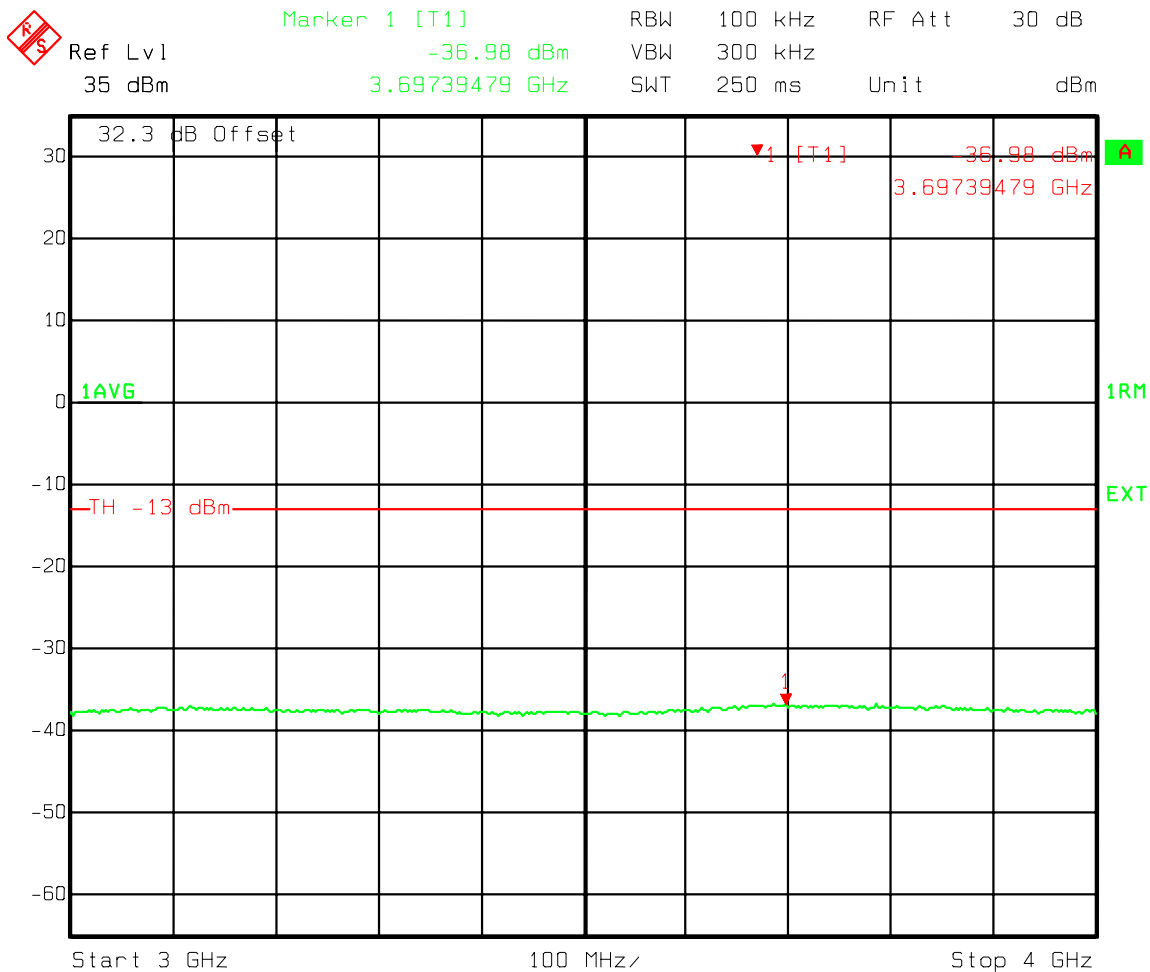

Date: 1.APR.2004 9:30:46

**Figure 109 : Three Carriers - B Band IS856 Spurious emissions 3000-4000 MHz**

**Three Channel 358, 399, 440 and 560, 601, 642 Spurious Emissions at the 800 MHz MFRM1 Maple Ant. Port Three Carrier band B IS856**

**B Band IS856 Spurious emissions 4000-5000 MHz**

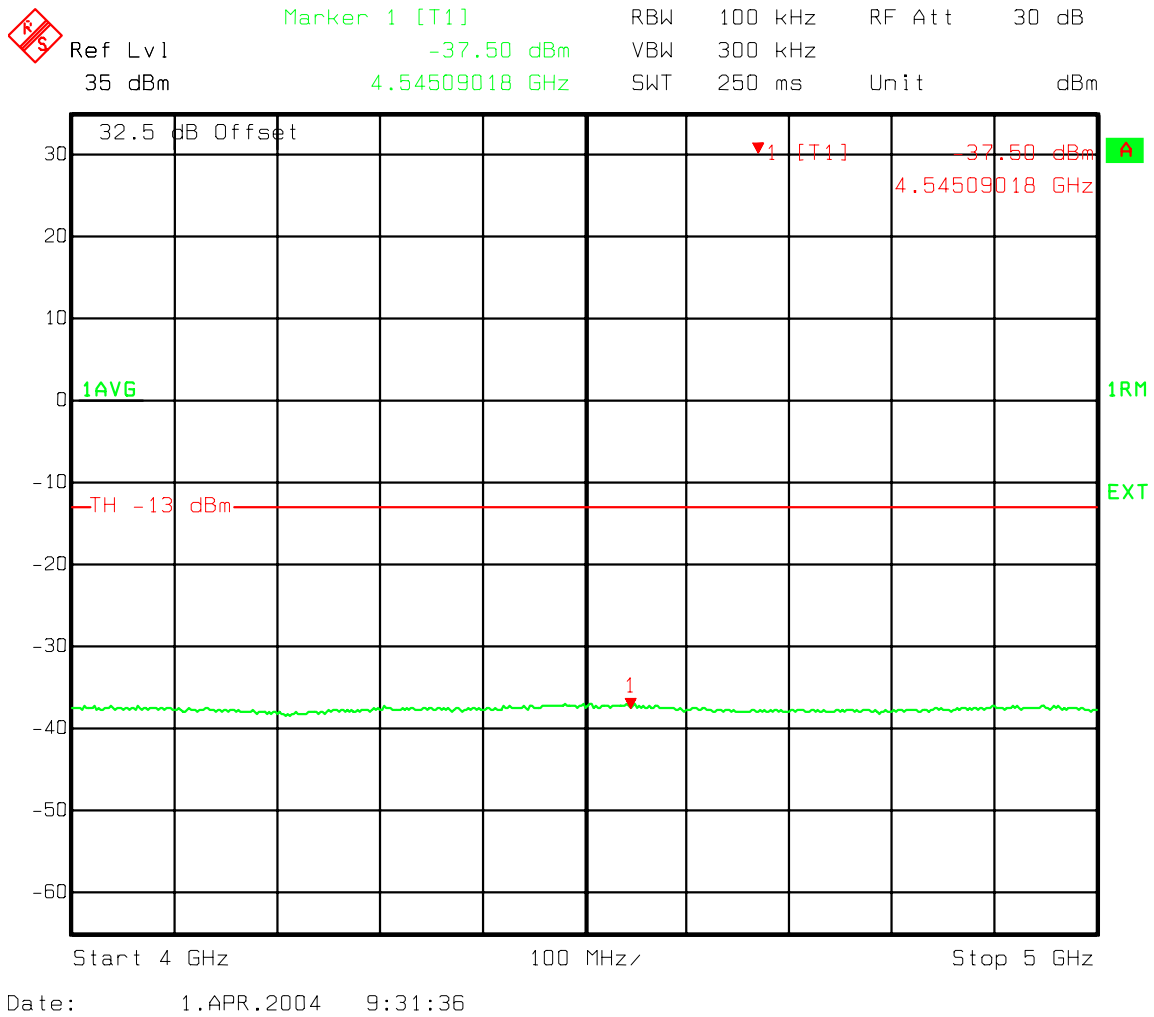
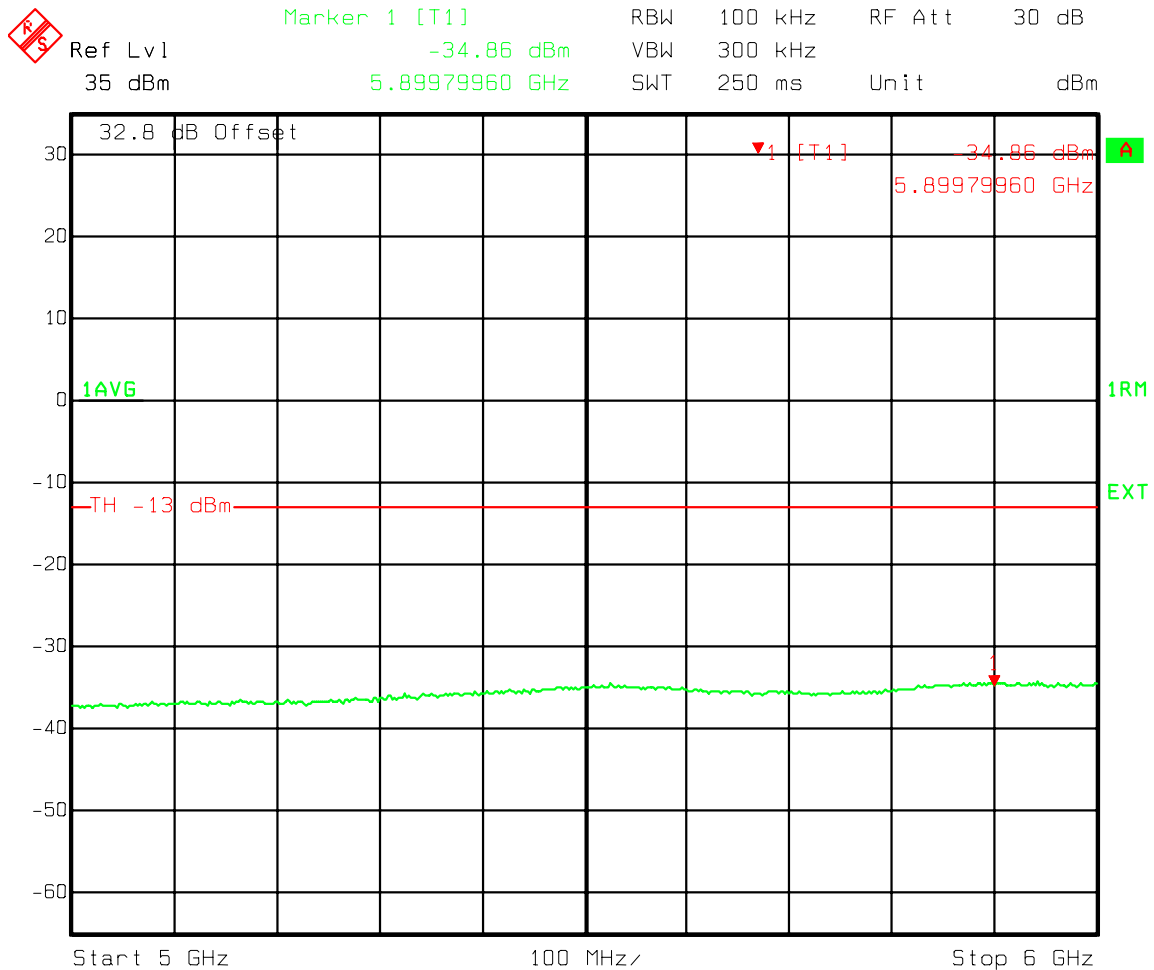

**Figure 110 : Three Carriers - B Band IS856 Spurious emissions 4000-5000 MHz**



**Three Channel 358, 399, 440 and 560, 601, 642 Spurious Emissions at the 800 MHz  
MFRM1 Maple Ant. Port Three Carrier band B IS856**

**B Band IS856 Spurious emissions 5000-6000 MHz**



Date: 1.APR.2004 9:32:28

**Figure 111 : Three Carriers - B Band IS856 Spurious emissions 5000-6000 MHz**

**Three Channel 358, 399, 440 and 560, 601, 642 Spurious Emissions at the 800 MHz MFRM1 Maple Ant. Port Three Carrier band B IS856**

**B Band IS856 Spurious emissions 6000-7000 MHz**

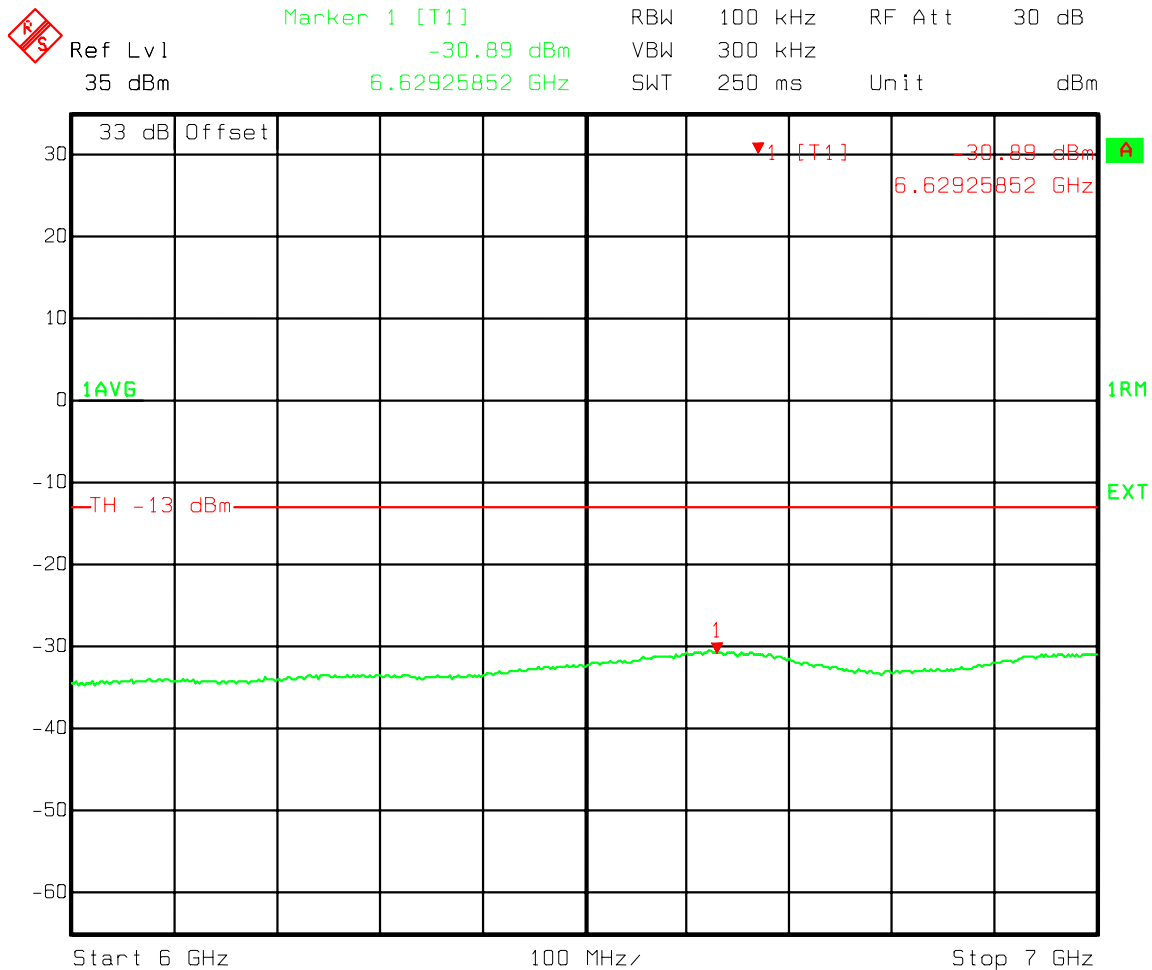

Date: 1.APR.2004 9:33:18

**Figure 112 : Three Carriers - B Band IS856 Spurious emissions 6000-7000 MHz**

**Three Channel 358, 399, 440 and 560, 601, 642 Spurious Emissions at the 800 MHz  
MFRM1 Maple Ant. Port Three Carrier band B IS856**

**B Band IS856 Spurious emissions 7000-8000 MHz**

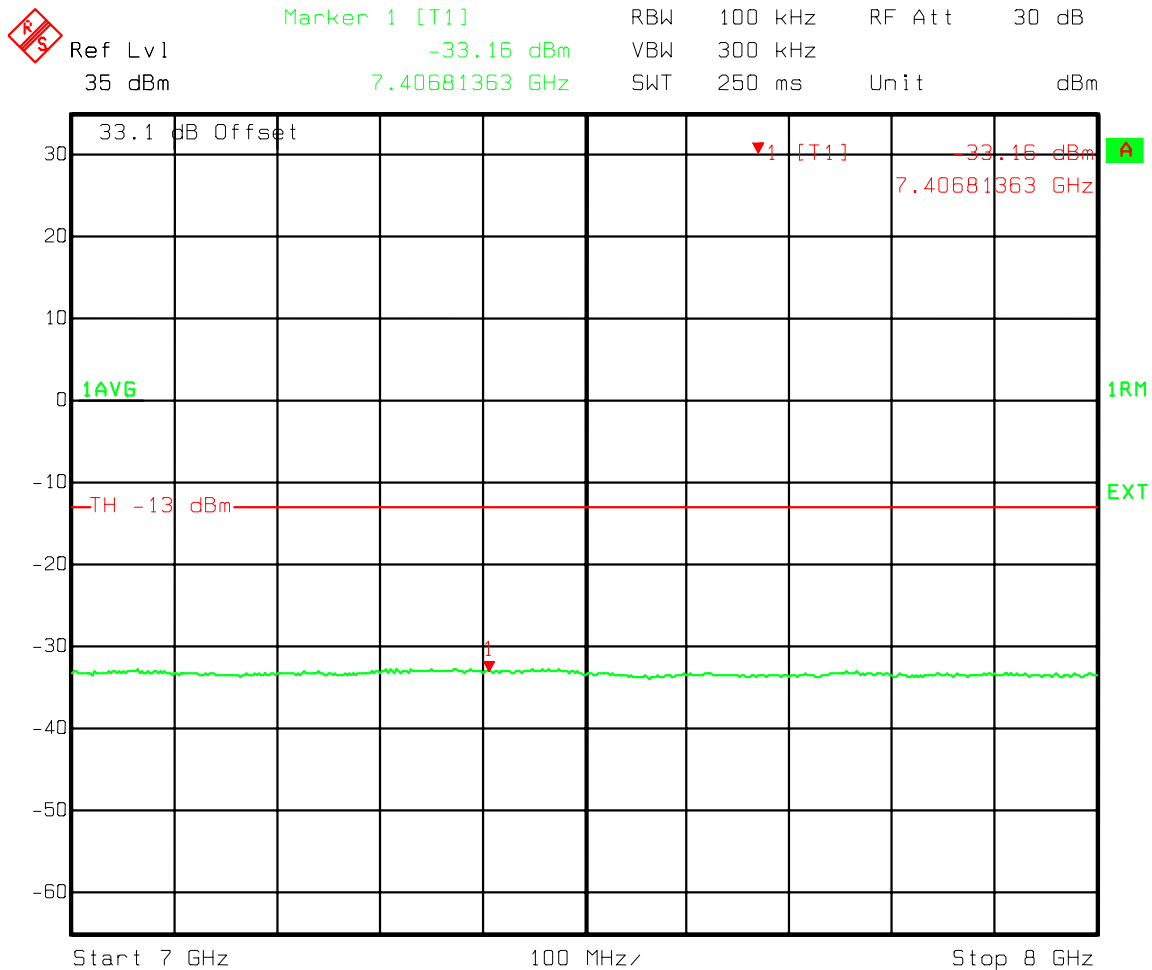

Date: 1.APR.2004 9:34:09

**Figure 113 : Three Carriers - B Band IS856 Spurious emissions 7000-8000 MHz**

**Three Channel 358, 399, 440 and 560, 601, 642 Spurious Emissions at the 800 MHz  
MFRM1 Maple Ant. Port Three Carrier band B IS856**

**B Band IS856 Spurious emissions 8000-9000 MHz**

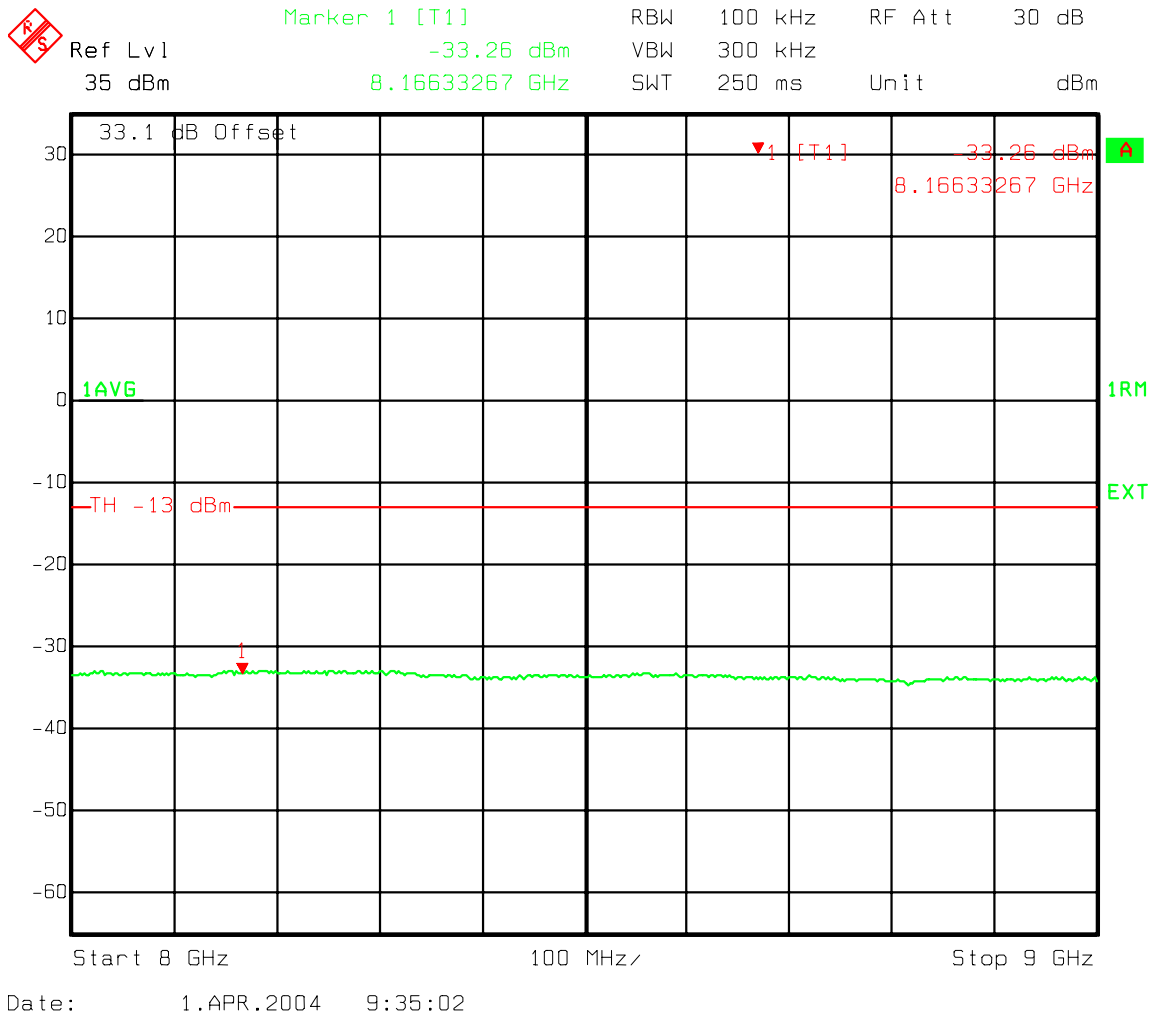

**Figure 114 : Three Carriers - B Band IS856 Spurious emissions 8000-9000 MHz**

**Three Channel 358, 399, 440 and 560, 601, 642 Spurious Emissions at the 800 MHz MFRM1 Maple Ant. Port Three Carrier band B IS856**

**B Band IS856 Spurious emissions 9000-10000 MHz**

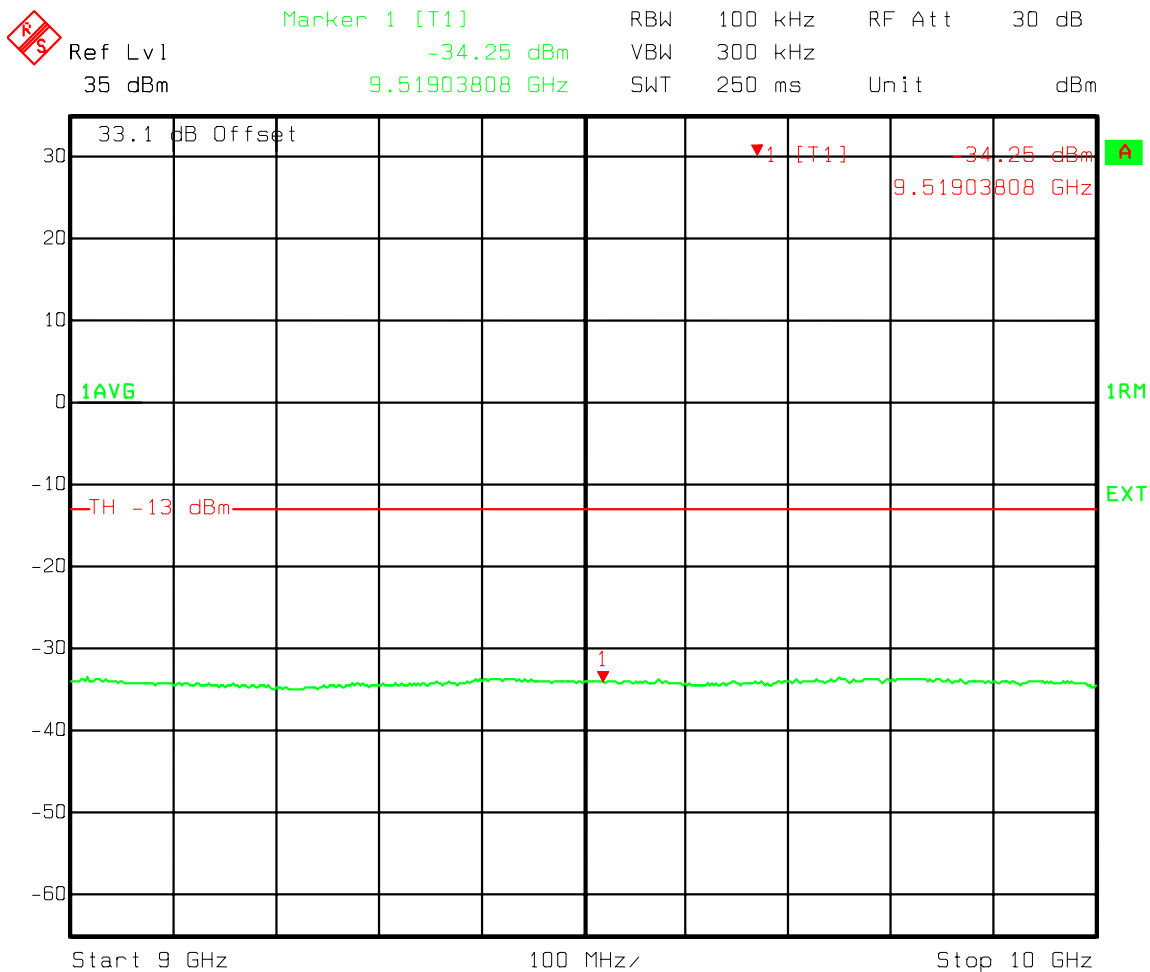

Date: 1.APR.2004 9:35:55

**Figure 115 : Three Carriers - B Band IS856 Spurious emissions 9000-10000 MHz**



# 10 Appendix F - Combined Three Carrier: 2-IS856 (358,399), 1-IS95 (440) Spurious Emission

**Combination Three Carrier 358 and 399 (IS856), 440 (IS95) Spurious Emissions at the 800 MHz MFRM-Maple Ant. Port band B**

**Occupied Bandwidth Ch 358, 399, 440 Band B**

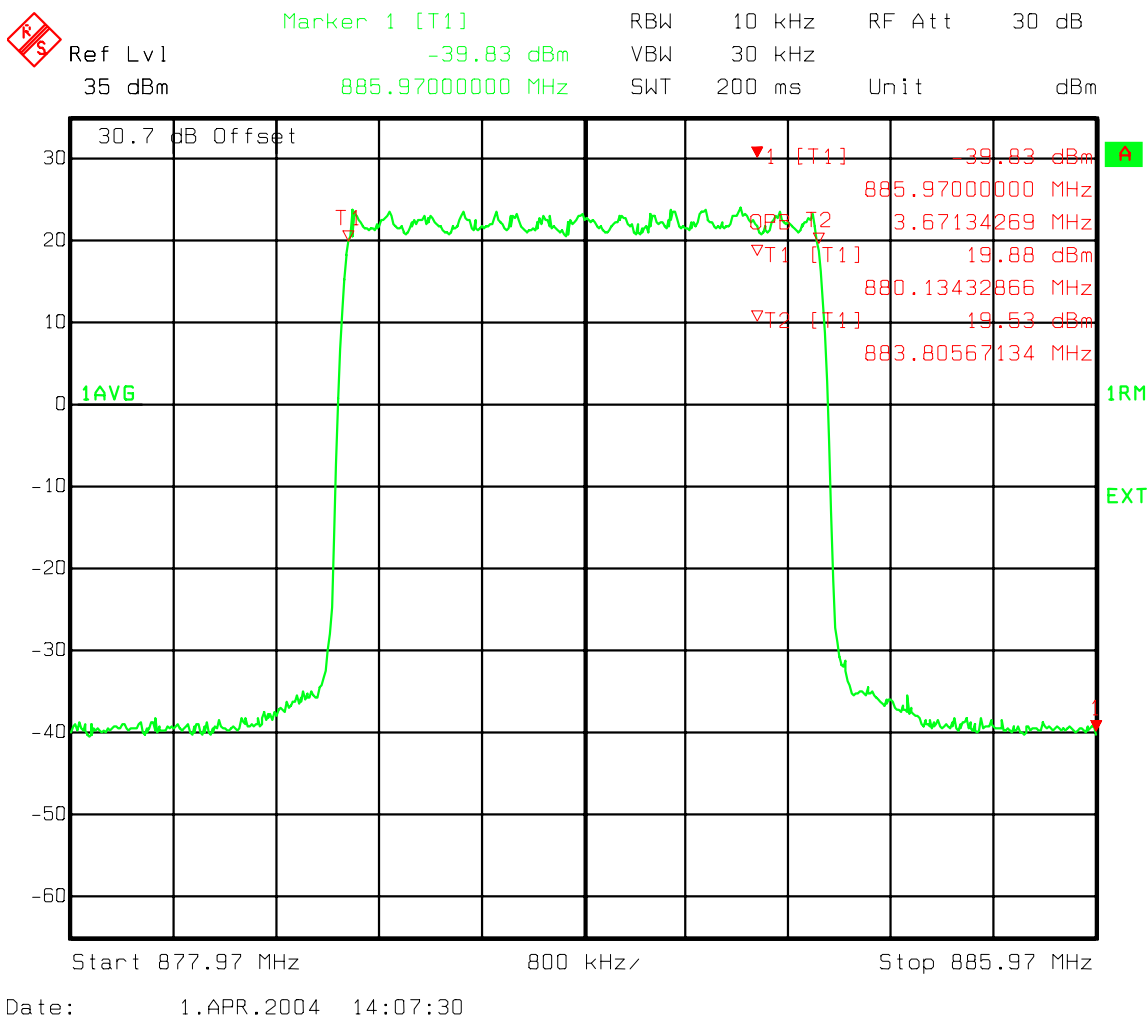

**Figure 116 : Combined Three Carriers - Occupied Bandwidth Ch 358, 399, 440**

**Combination Three Carrier 358 and 399 (IS856), 440 (IS95) Spurious Emissions at the 800 MHz MFRM-Maple Ant. Port band B**

**B Band Ch 358, 399, 440 IS856/IS95 Adjacent 1Mhz Lower emissions 879-880MHz**

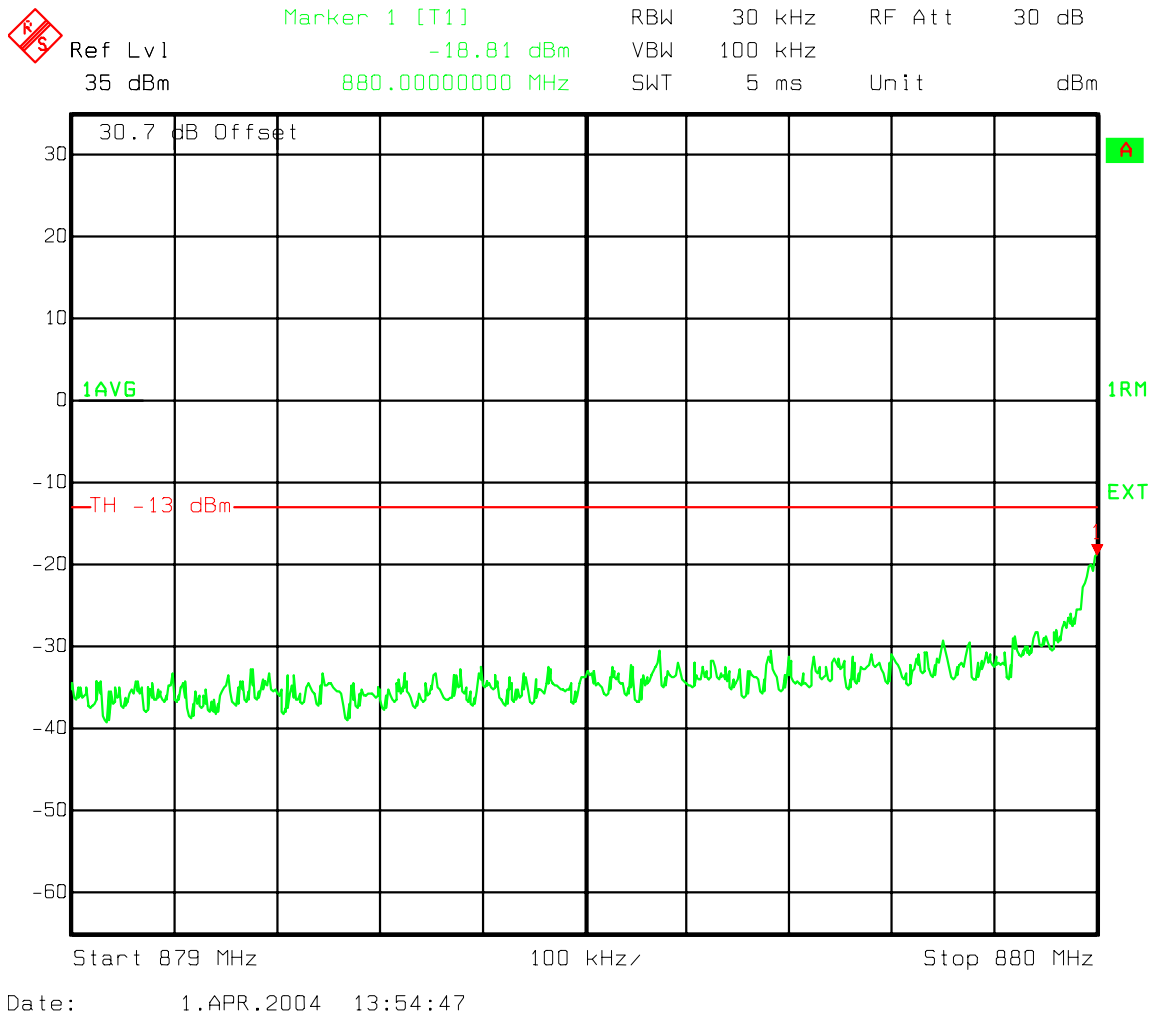
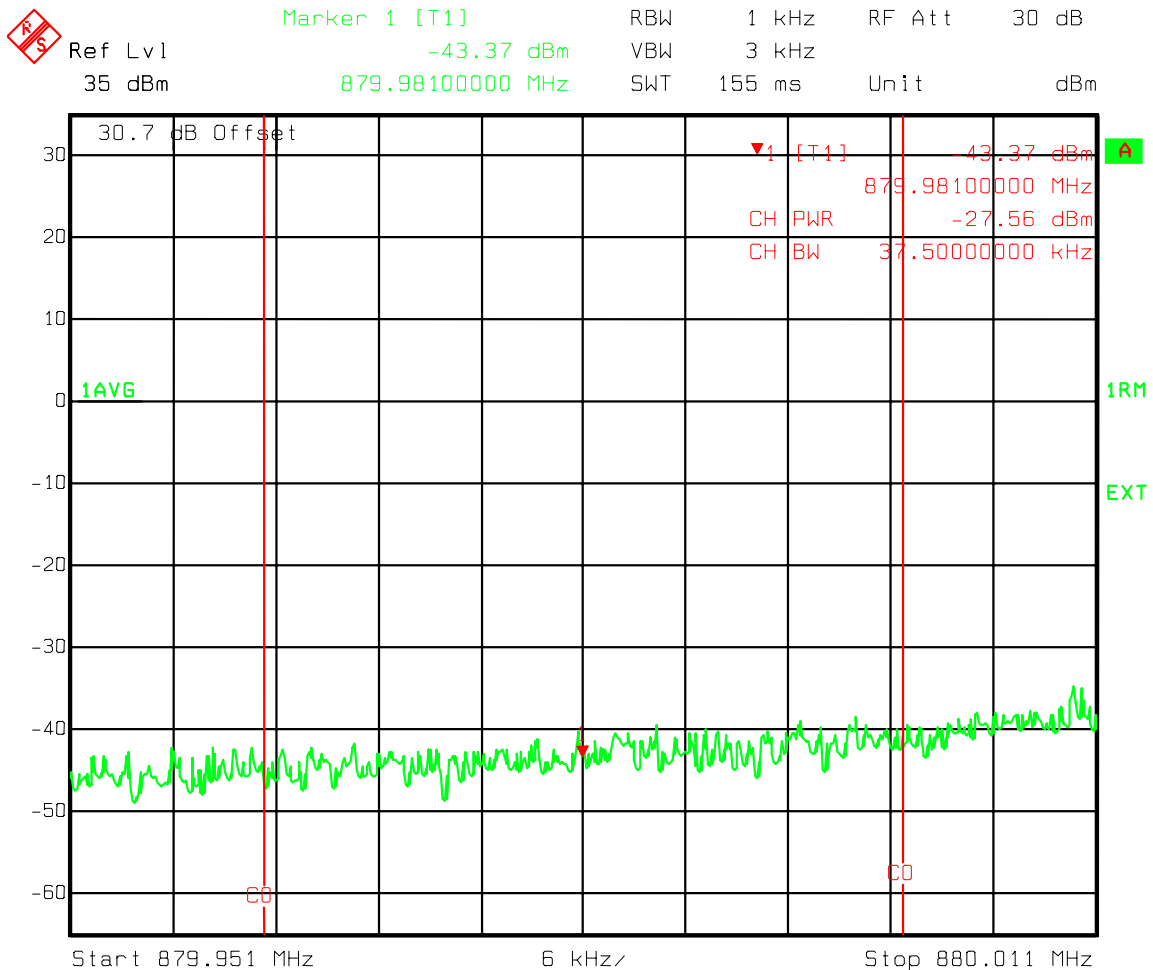

**Figure 117 : Combined Three Carriers - B Band Ch 358, 399 (IS856), 440 IS95 Adjacent 1MHz Lower emissions 879-880MHz**



**Combination Three Carrier 358 and 399 (IS856), 440 (IS95) Spurious Emissions at the 800 MHz MFRM-Maple Ant. Port band B**

**B Band Ch358, 399, 440 IS856/IS95 Channel power Adjacent 37.5 kHz Lower emissions to 880 MHz**



Date: 1.APR.2004 13:55:36

**Figure 118 : Combined Three Carriers - Ch 358, 399 (IS856), 440 (IS95) Lower B Band Adjacent to outside edge 37.5kHz band Channel Power**

**Combination Three Carrier 358 and 399 (IS856), 440 (IS95) Spurious Emissions at the 800 MHz MFRM-Maple Ant. Port band B**

**Ch560, 601, 642 Upper B Band adjacent 1MHz band emissions**

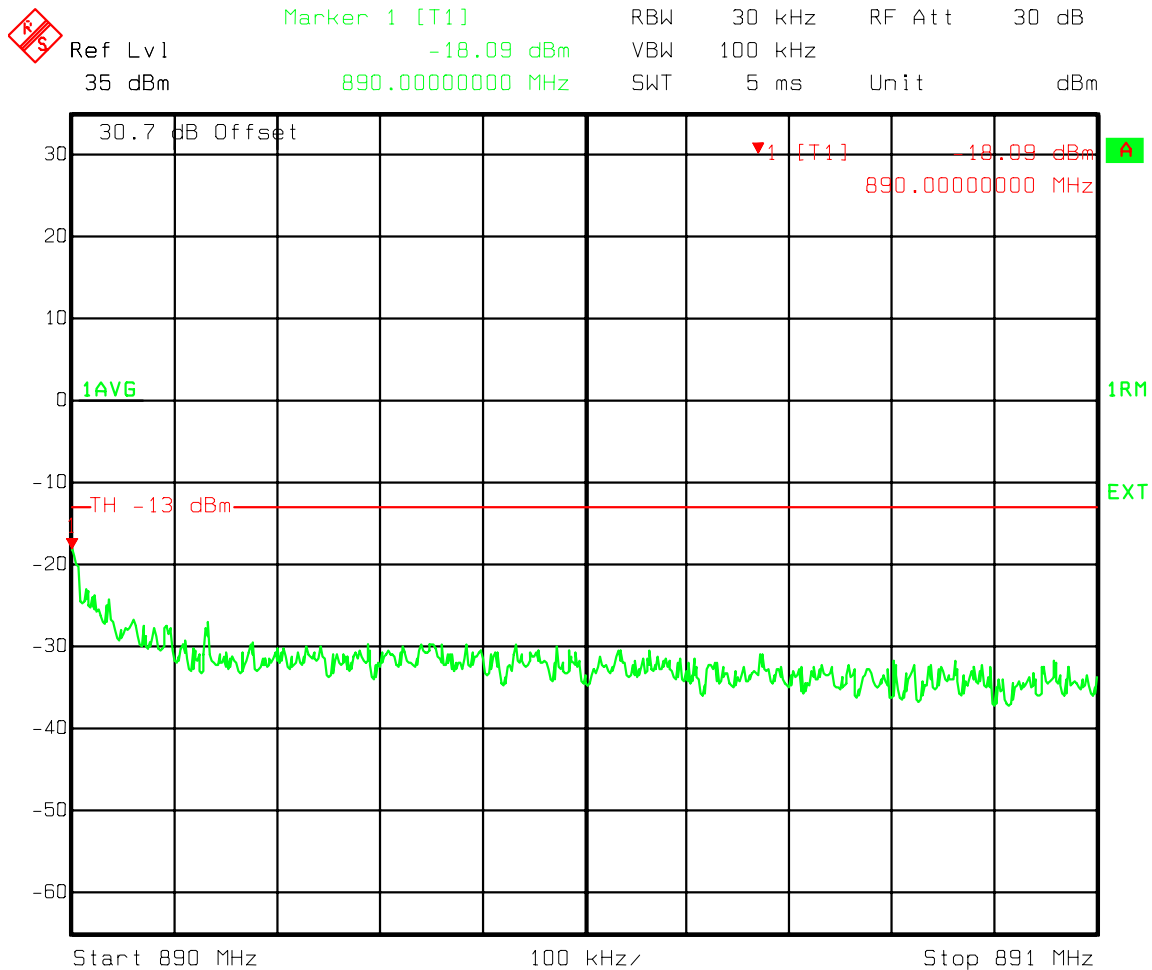

Date: 1.APR.2004 12:01:16

**Figure 119 : Combined Three Carriers - Ch 560, 601, 642 Upper a Band adjacent 1 MHz band emissions 890-891 MHz**

**Combination Three Carrier 358 and 399 (IS856), 440 (IS95) Spurious Emissions at the 800 MHz MFRM-Maple Ant. Port band B**

**Ch560, 601, 642 Upper adjacent 1MHz band 37.5 kHz band Channel power**

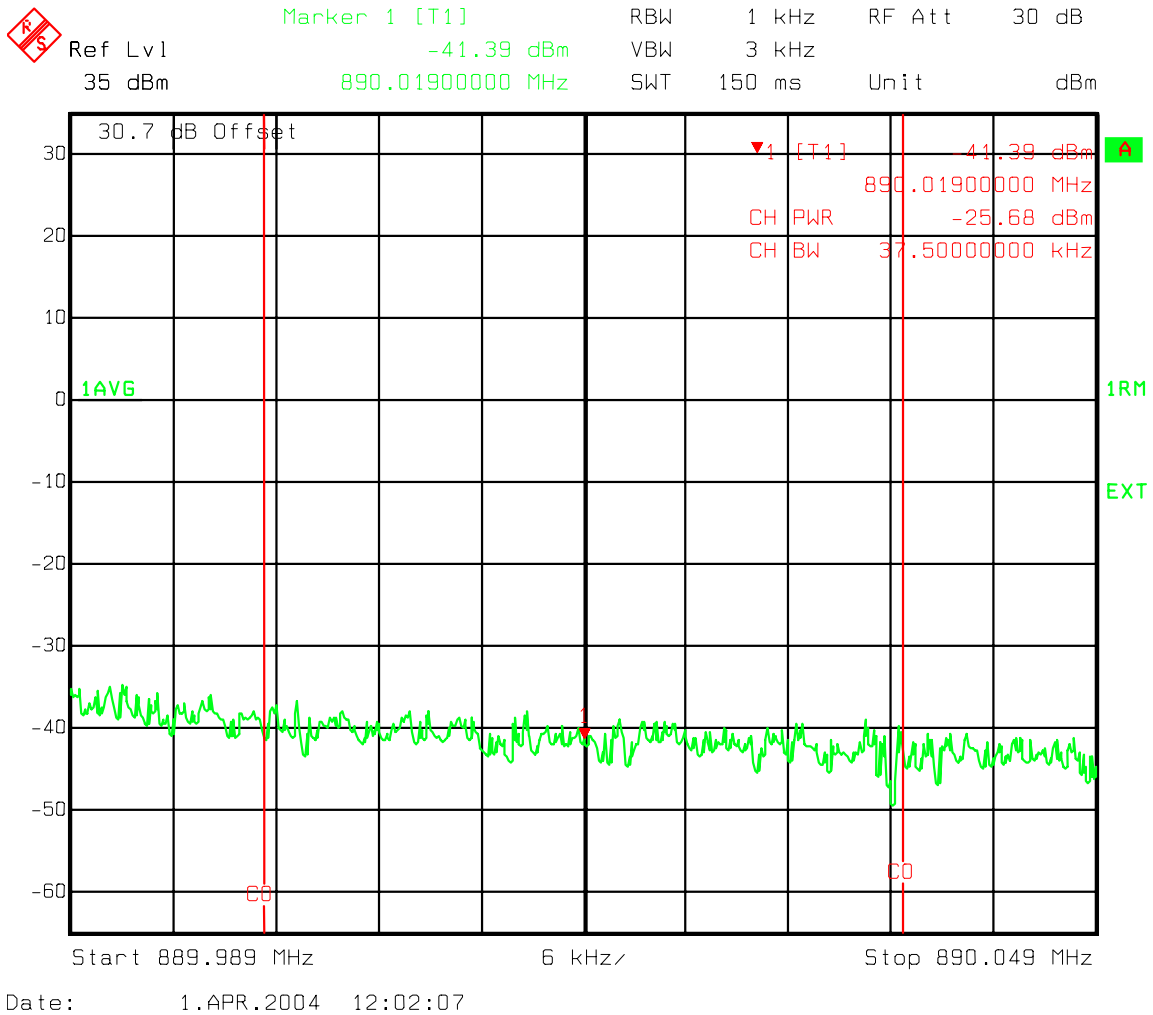

**Figure 120 : Three Carriers - Ch 560, 601, 642 Upper B Band adjacent to outside edge 37.5 kHz band Channel power**

**Combination Three Carrier 358 and 399 (IS856), 440 (IS95) Spurious Emissions at the 800 MHz MFRM-Maple Ant. Port band B**

**Industry Canada Lower 750 kHz offset 30kHz Chan Power Ch 358, 399, 440**

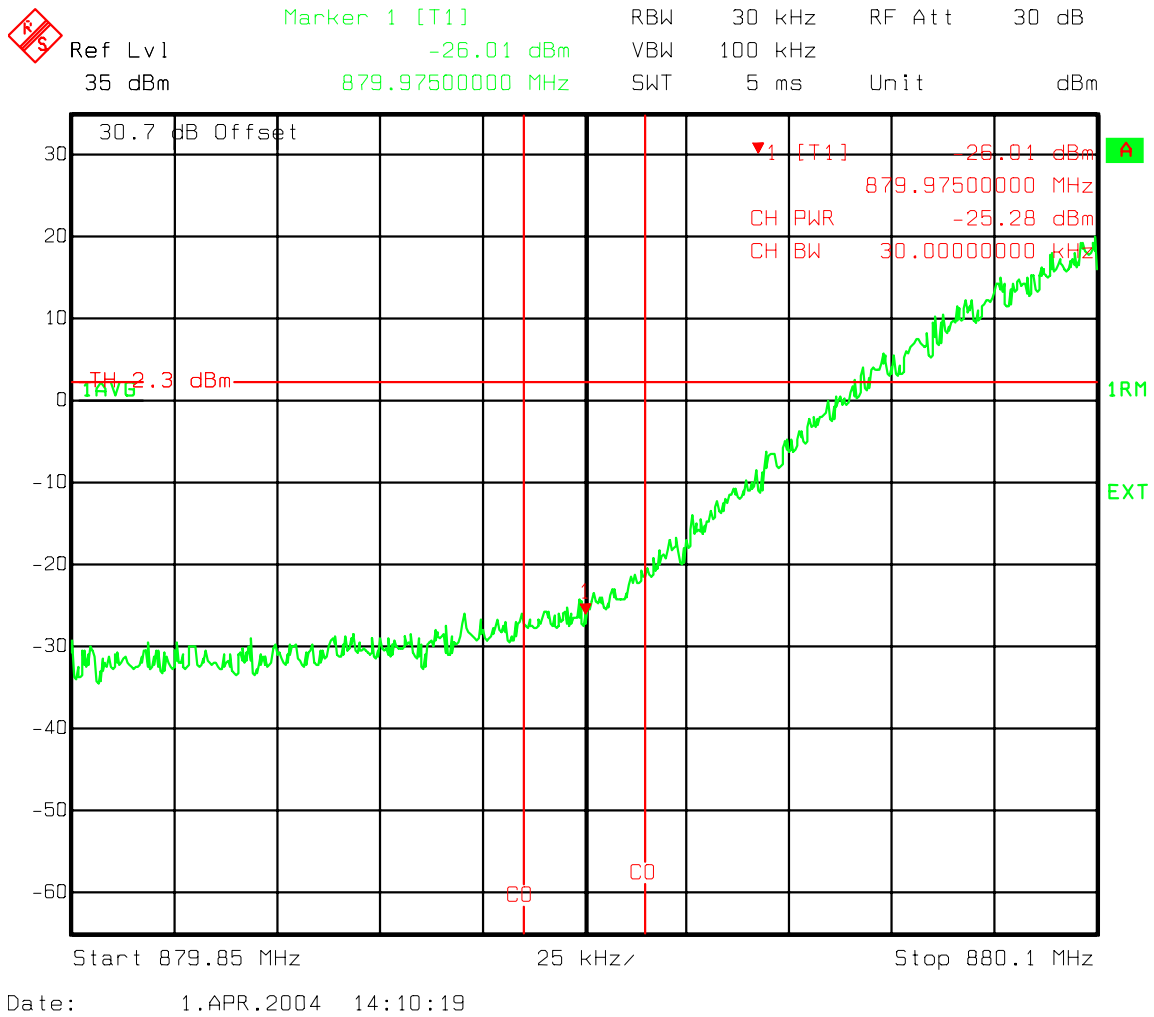

**Figure 121 : Combined Three Carriers - Industry Canada Lower 750 kHz offset 30 kHz Chan Power Ch 358, 399 (IS856), 440 (IS95)**

**Combination Three Carrier 358 and 399 (IS856), 440 (IS95) Spurious Emissions at the 800 MHz MFRM-Maple Ant. Port band B**

**Industry Canada Upper 750 kHz offset 30kHz Chan Power Ch 358, 399, 440**

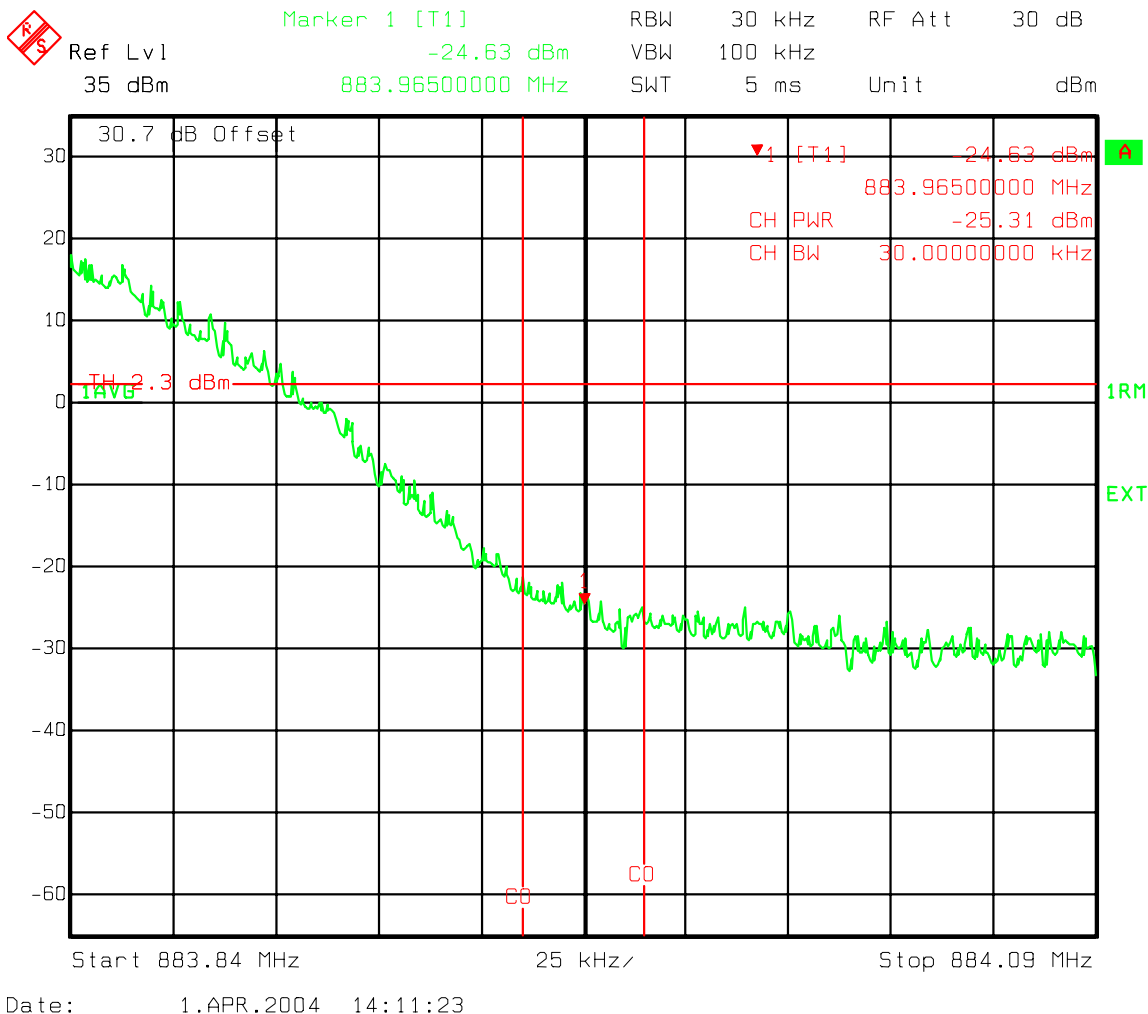

**Figure 122 : Combined Three Carriers - Industry Canada Upper 750 kHz offset 30 kHz Chan Power Ch 358, 399 (IS856), 440 (IS95)**

**Combination Three Carrier 358 and 399 (IS856), 440 (IS95) Spurious Emissions at the 800 MHz MFRM-Maple Ant. Port band B**

**Industry Canada 1.98 MHz offset Lower 30kHz Chan Power Ch 358, 399, 440**

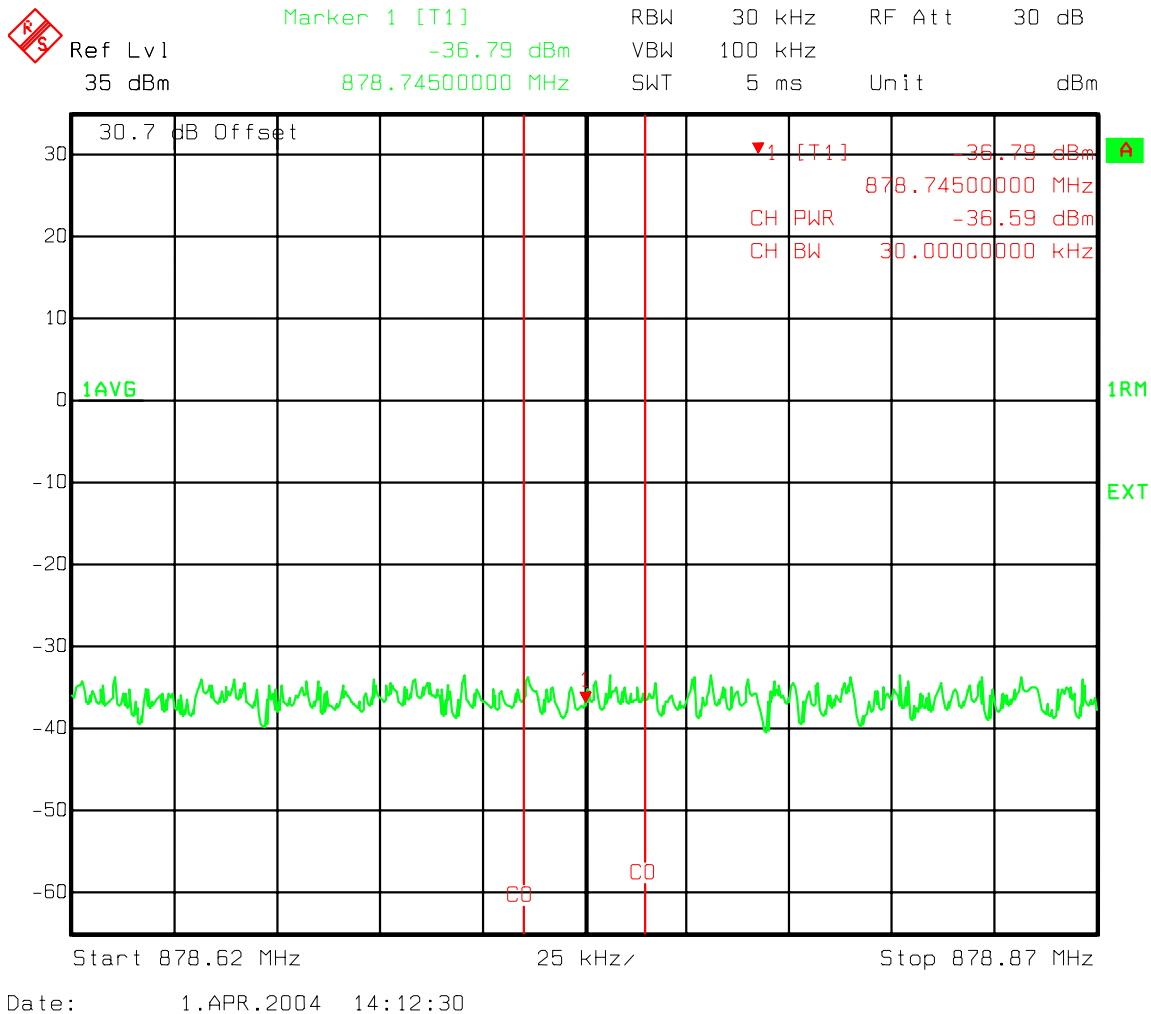

**Figure 123 : Combined Three Carriers - Industry Canada 1.98 MHz offset Lower 30 kHz Chan Power Ch 358, 399 (IS856), 440 (IS95)**

**Combination Three Carrier 358 and 399 (IS856), 440 (IS95) Spurious Emissions at the 800 MHz MFRM-Maple Ant. Port band B**

**Industry Canada 1.98 MHz offset Upper 30kHz Chan Power Ch 358, 399, 440**

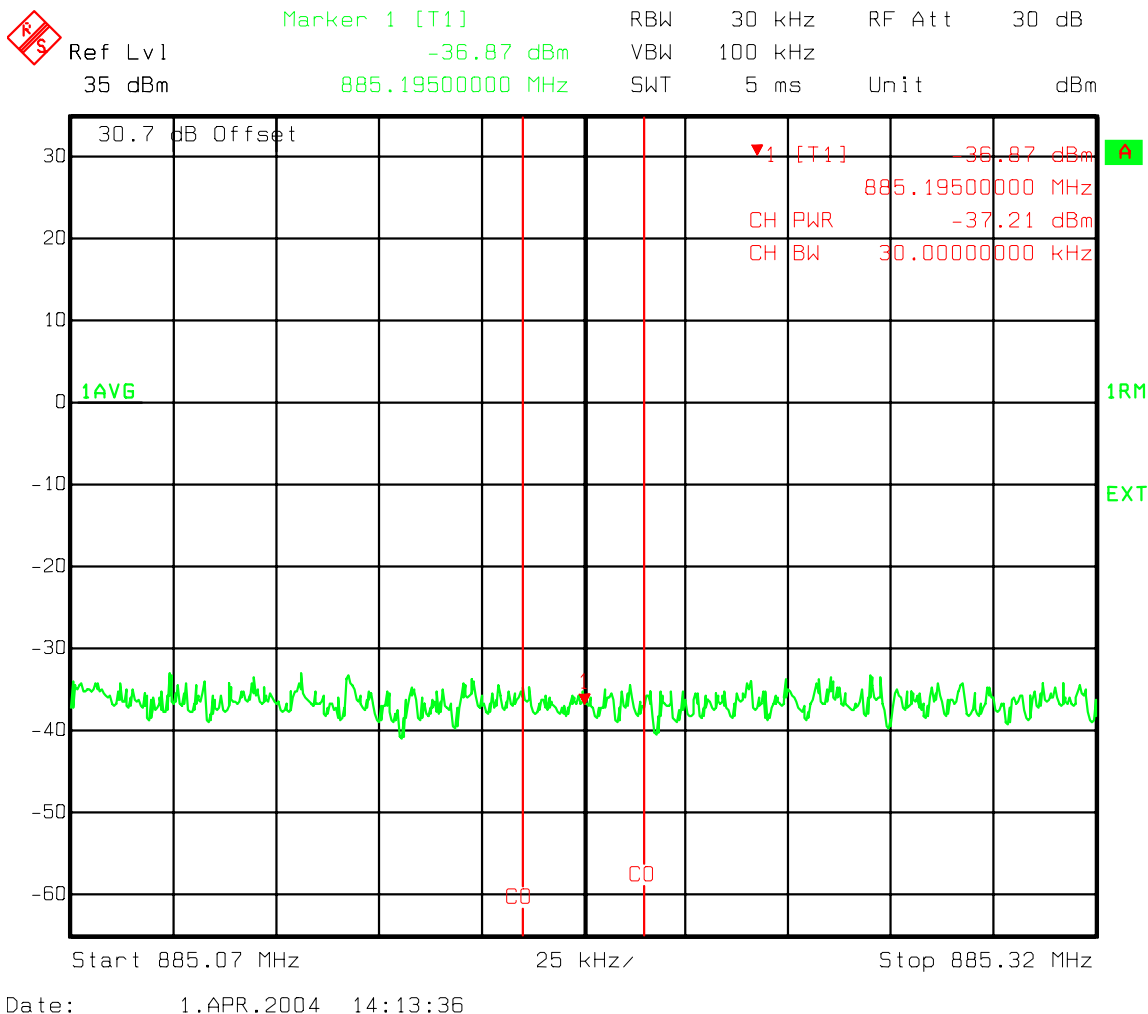

**Figure 124 : Combined Three Carriers - Industry Canada 1.98 MHz offset Upper 30 kHz Chan Power Ch 358, 399 (IS856), 440 (IS95)**

**Combination Three Carrier 358 and 399 (IS856), 440 (IS95) Spurious Emissions at the 800 MHz MFRM-Maple Ant. Port band B**

**B Band IS856/IS95 Spurious emissions 10kHz-400 MHz**

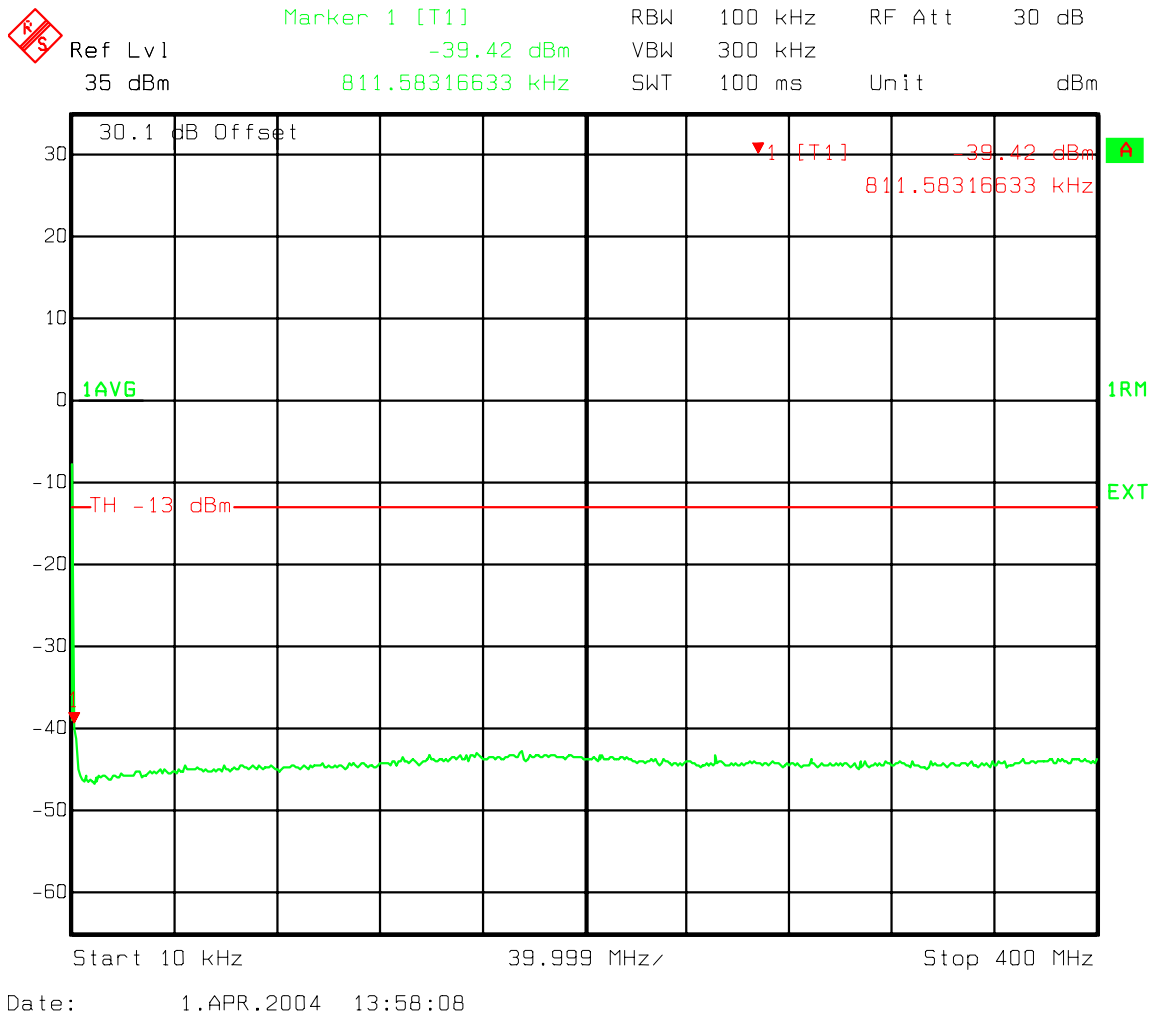
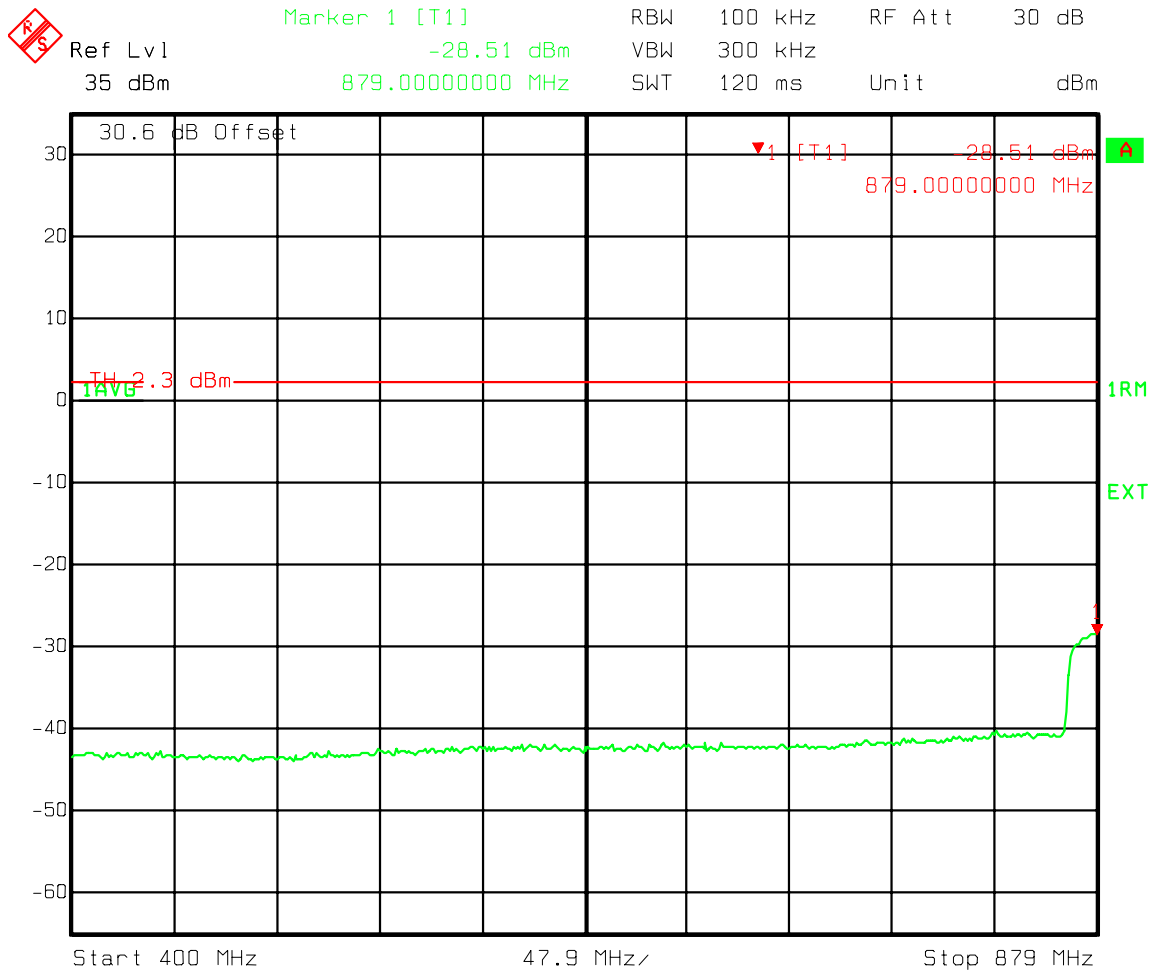

**Figure 125 : Combined Three Carriers - B Band IS856 Spurious emissions 10kHz-400 MHz**



**Combination Three Carrier 358 and 399 (IS856), 440 (IS95) Spurious Emissions at the 800 MHz MFRM-Maple Ant. Port band B**

**B Band IS856/IS95 Spurious emissions 400MHz to Lower 1MHz Band Edge**



Date: 1.APR.2004 14:14:44

**Figure 126 : Combined Three Carriers - B Band IS856 Spurious emissions 400 MHz to Lower 1 MHz Band Edge**

**Combination Three Carrier 358 and 399 (IS856), 440 (IS95) Spurious Emissions at the 800 MHz MFRM-Maple Ant. Port band B**

**B Band IS856/IS95 Spurious emissions Upper 1MHz Band Edge to 1GHz**

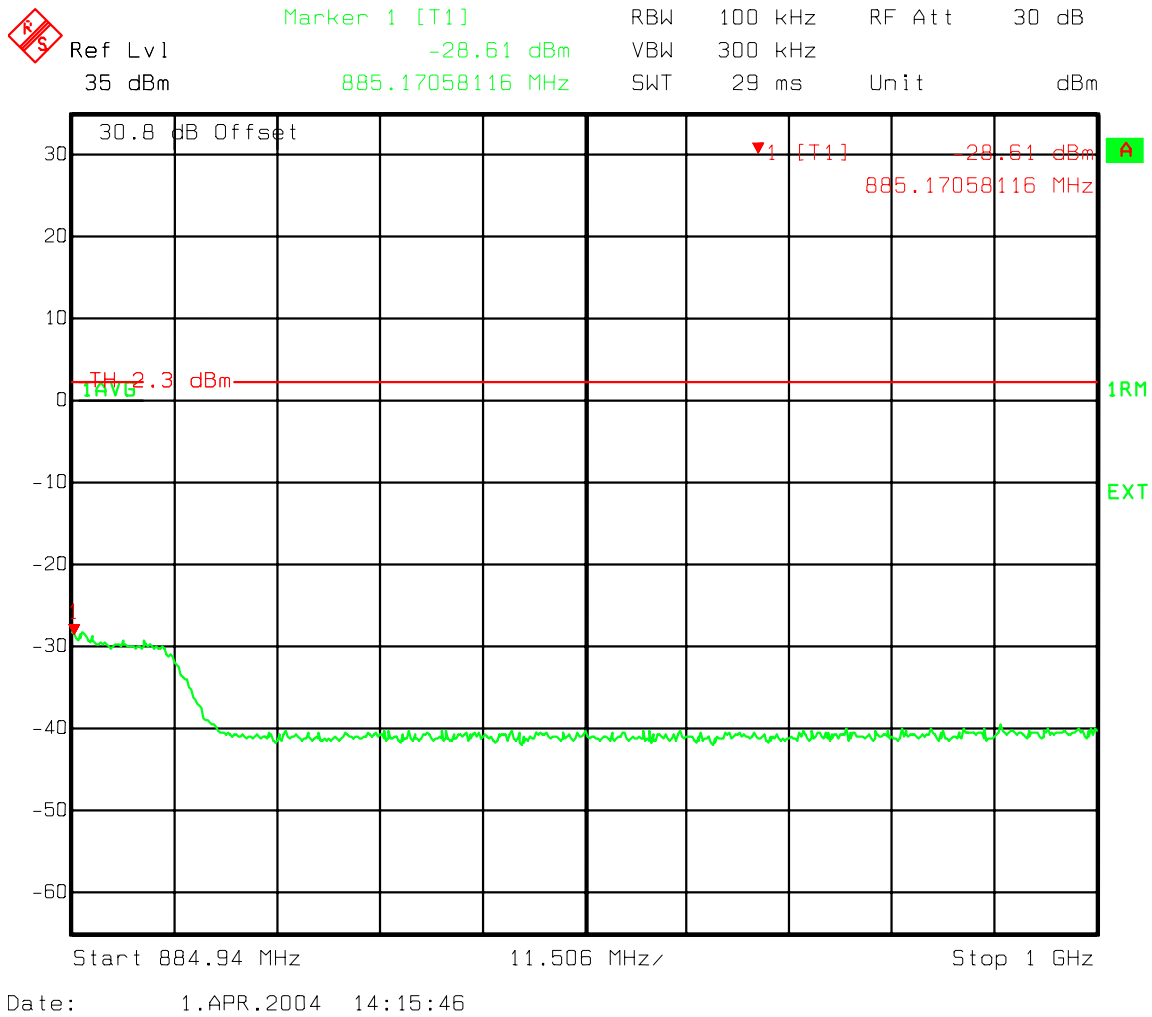

**Figure 127 : Combined Three Carriers - B Band IS856 Spurious emissions Upper 1 MHz Band Edge to 1 GHz**

**Combination Three Carrier 358 and 399 (IS856), 440 (IS95) Spurious Emissions at the 800 MHz MFRM-Maple Ant. Port band B**

**B Band IS856/IS95 Spurious emissions 400-1000 MHz**

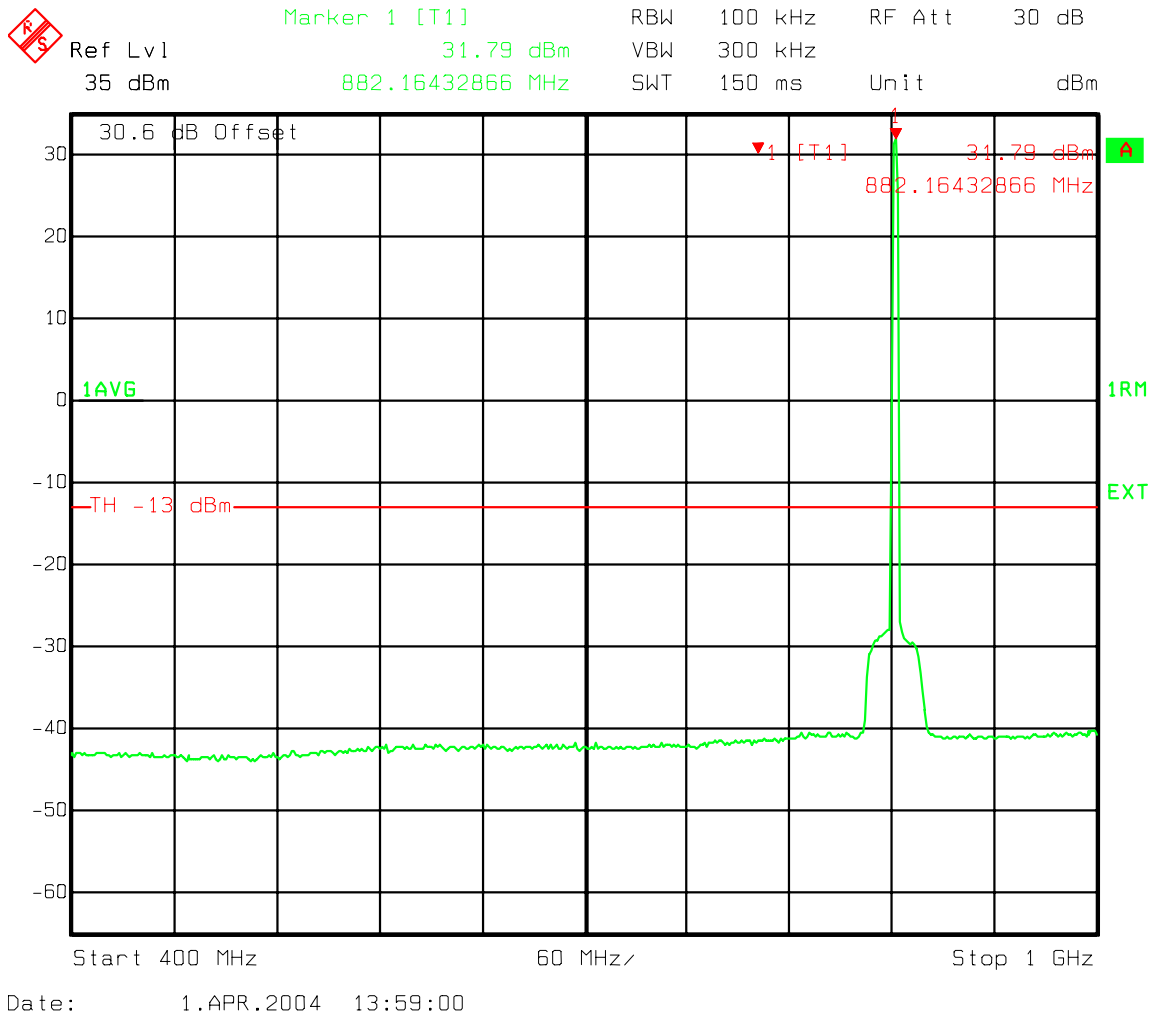

**Figure 128 : Combined Three Carriers - B Band IS856 Spurious emissions 400-1000 MHz**

**Combination Three Carrier 358 and 399 (IS856), 440 (IS95) Spurious Emissions at the 800 MHz MFRM-Maple Ant. Port band B**

**B Band IS856/IS95 Spurious emissions 1000-2000 MHz**

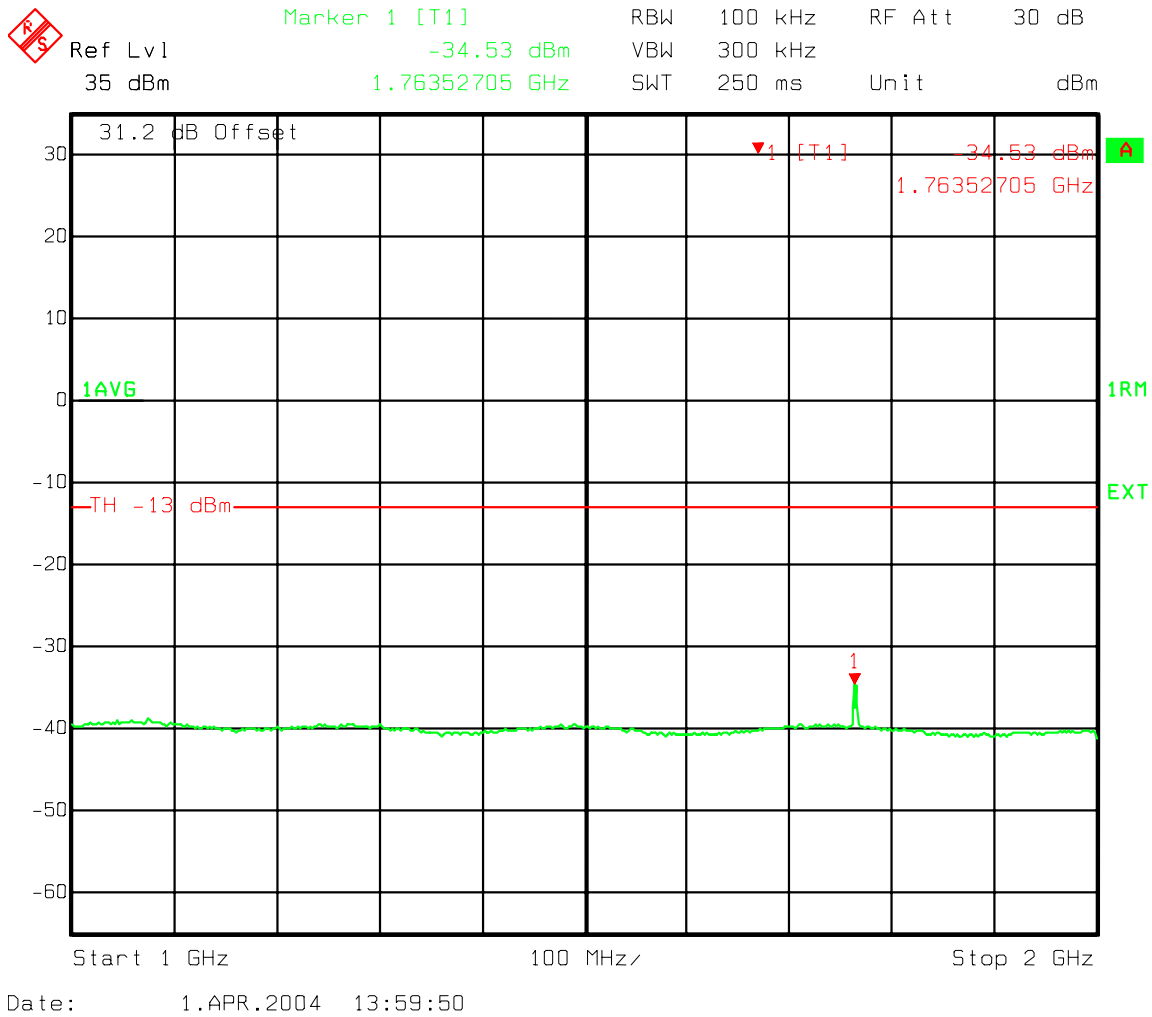

**Figure 129 : Combined Three Carriers - B Band 2-IS856/1-IS95 Spurious emissions 1000-2000 MHz**

**Combination Three Carrier 358 and 399 (IS856), 440 (IS95) Spurious Emissions at the 800 MHz MFRM-Maple Ant. Port band B**

**B Band IS856/IS95 Spurious emissions 2000-3000 MHz**

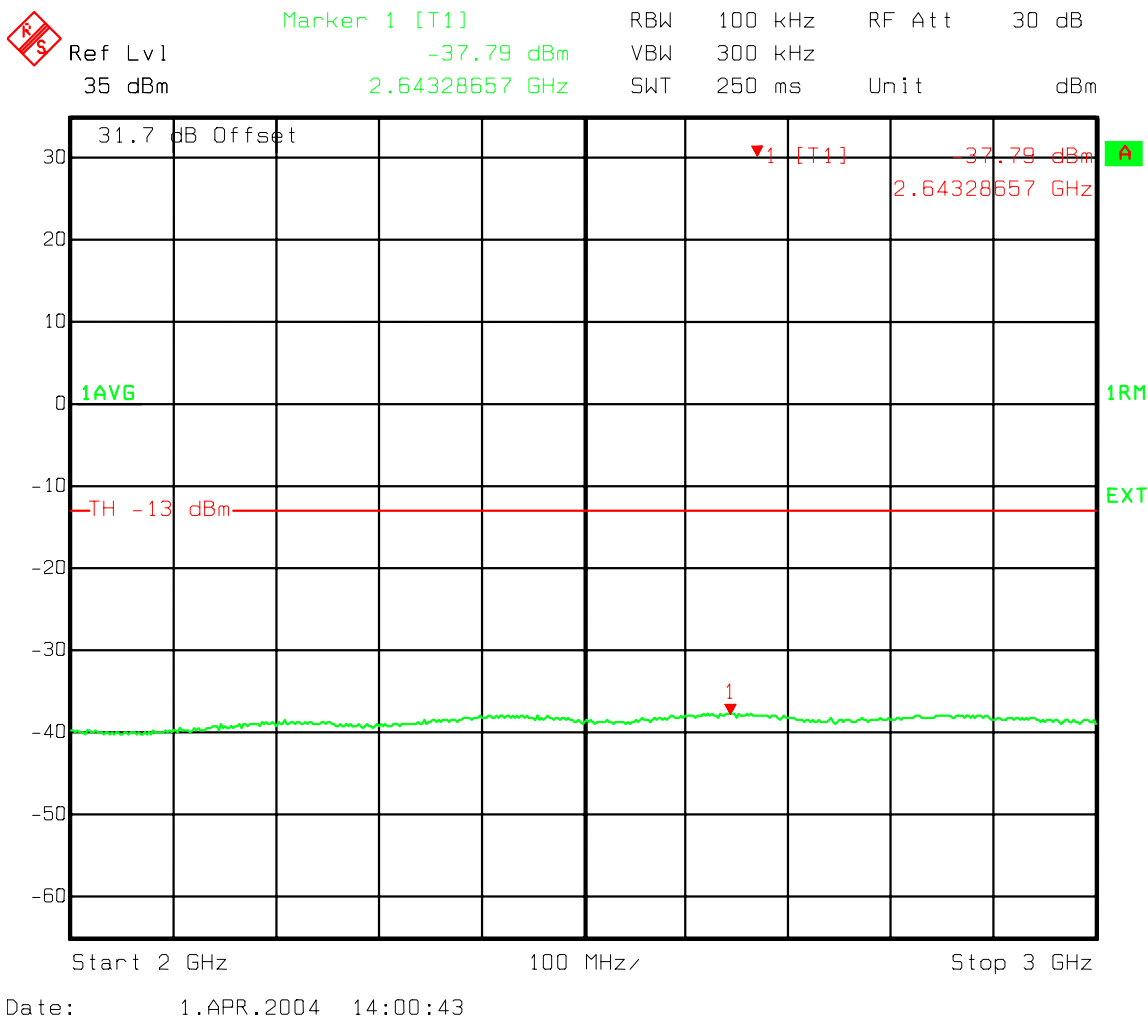

**Figure 130 : Combined Three Carriers - B Band 2-IS856/1-IS95 Spurious emissions 2000-3000 MHz**

**Combination Three Carrier 358 and 399 (IS856), 440 (IS95) Spurious Emissions at the 800 MHz MFRM-Maple Ant. Port band B**

**B Band IS856/IS95 Spurious emissions 3000-4000 MHz**

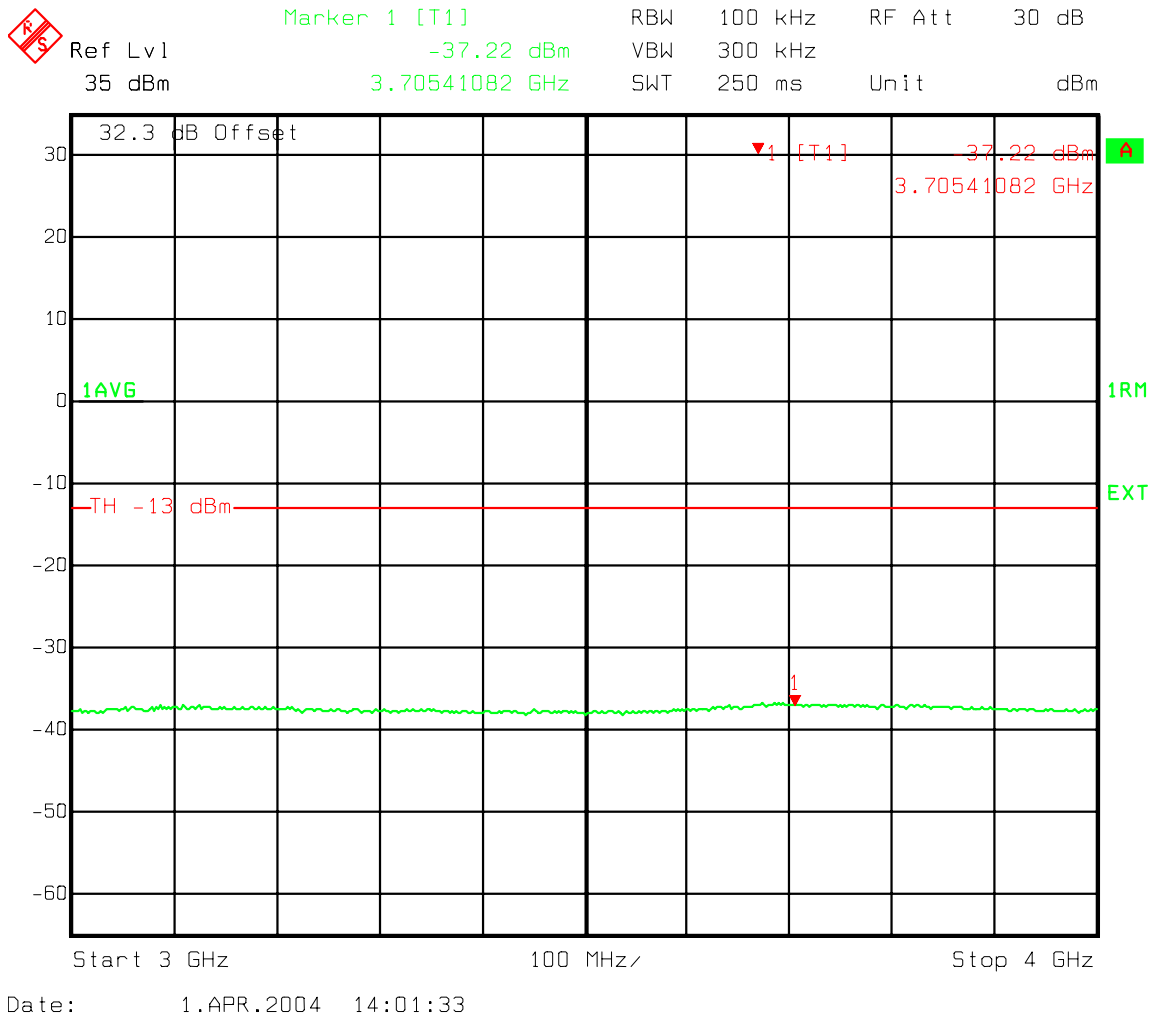

**Figure 131 : Combined Three Carriers - B Band 2-IS856/1-IS95 Spurious emissions 3000-4000 MHz**

**Combination Three Carrier 358 and 399 (IS856), 440 (IS95) Spurious Emissions at the 800 MHz MFRM-Maple Ant. Port band B**

**B Band IS856/IS95 Spurious emissions 4000-5000 MHz**

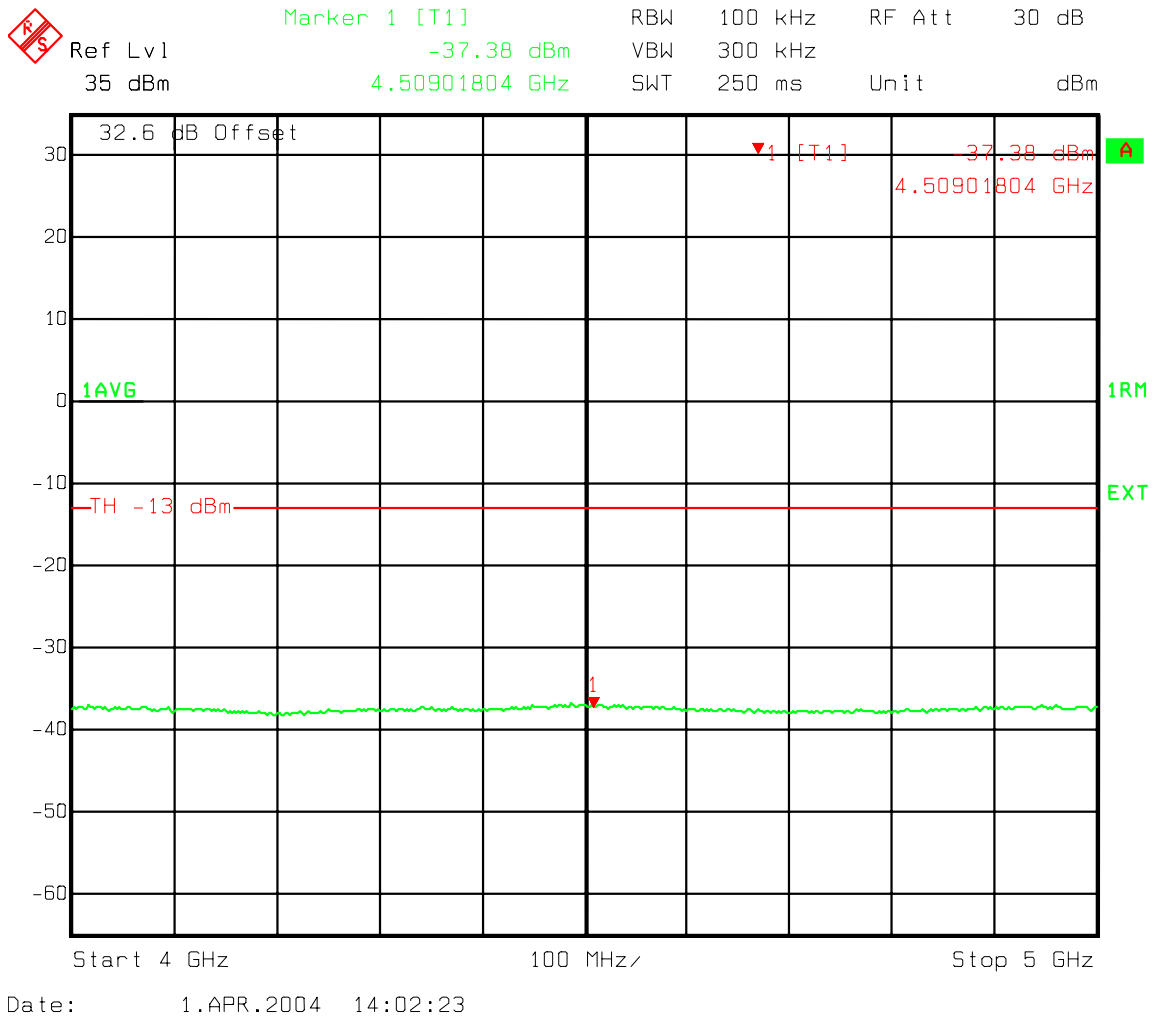

**Figure 132 : Combined Three Carriers - B Band 2-IS856/1-IS95 Spurious emissions 4000-5000 MHz**

**Combination Three Carrier 358 and 399 (IS856), 440 (IS95) Spurious Emissions at the 800 MHz MFRM-Maple Ant. Port band B**

**B Band IS856/IS95 Spurious emissions 5000-6000 MHz**

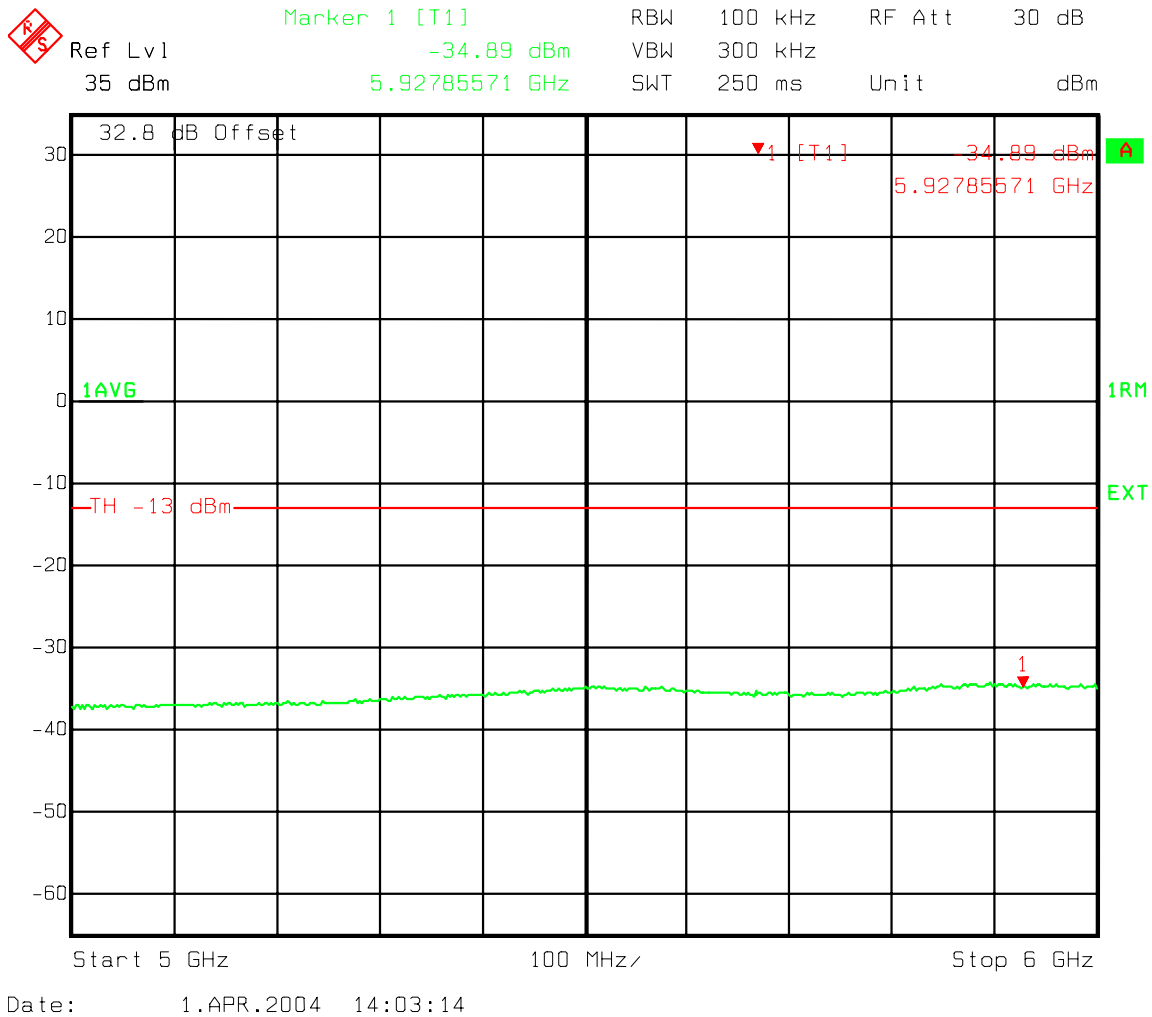
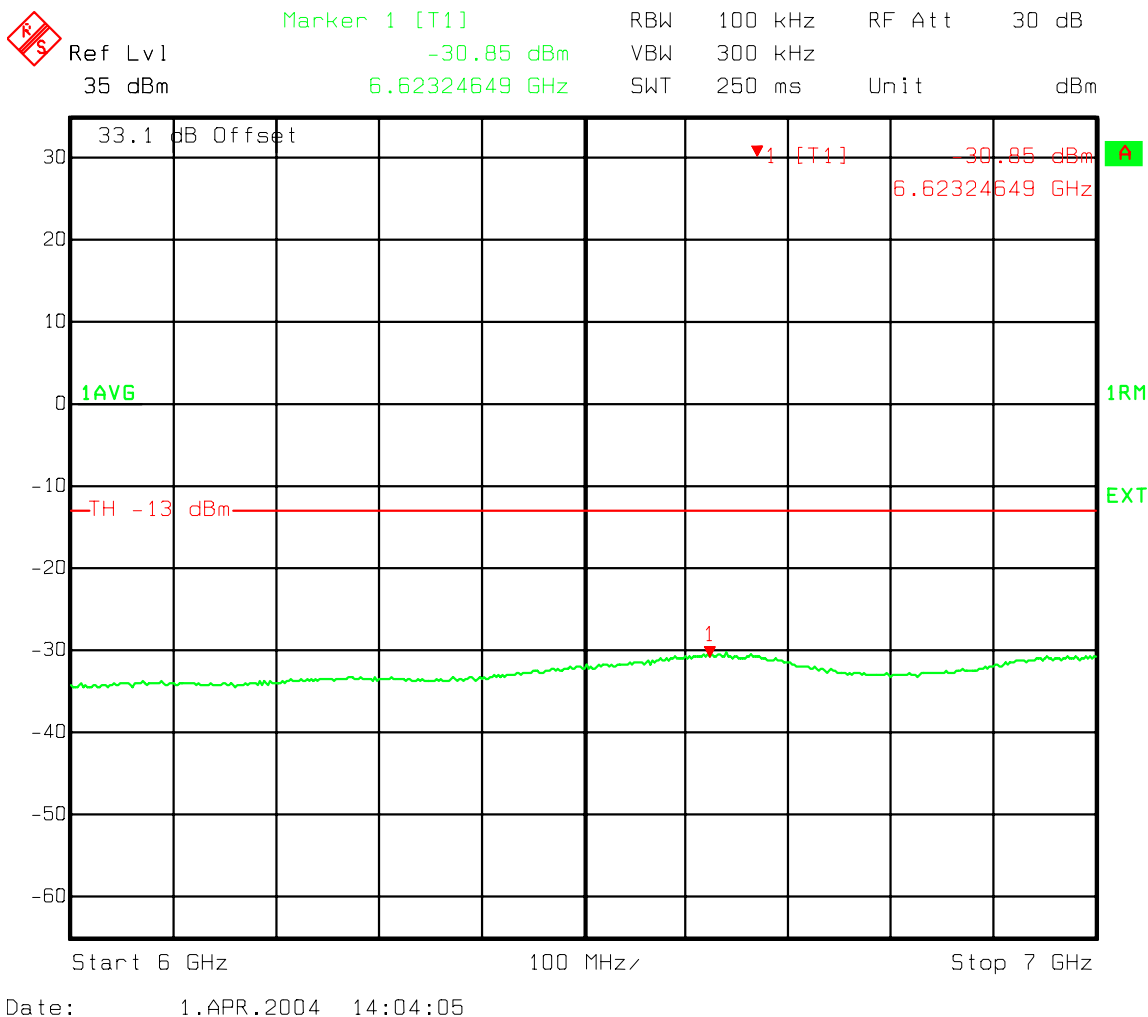

**Figure 133 : Combined Three Carriers - B Band 2-IS856/1-IS95 Spurious emissions 5000-6000 MHz**



**Combination Three Carrier 358 and 399 (IS856), 440 (IS95) Spurious Emissions at the 800 MHz MFRM-Maple Ant. Port band B**

**B Band IS856/IS95 Spurious emissions 6000-7000 MHz**



**Figure 134 : Combined Three Carriers - B Band 2-IS856/1-IS95 Spurious emissions 6000-7000 MHz**

**Combination Three Carrier 358 and 399 (IS856), 440 (IS95) Spurious Emissions at the 800 MHz MFRM-Maple Ant. Port band B**

**B Band IS856/IS95 Spurious emissions 7000-8000 MHz**

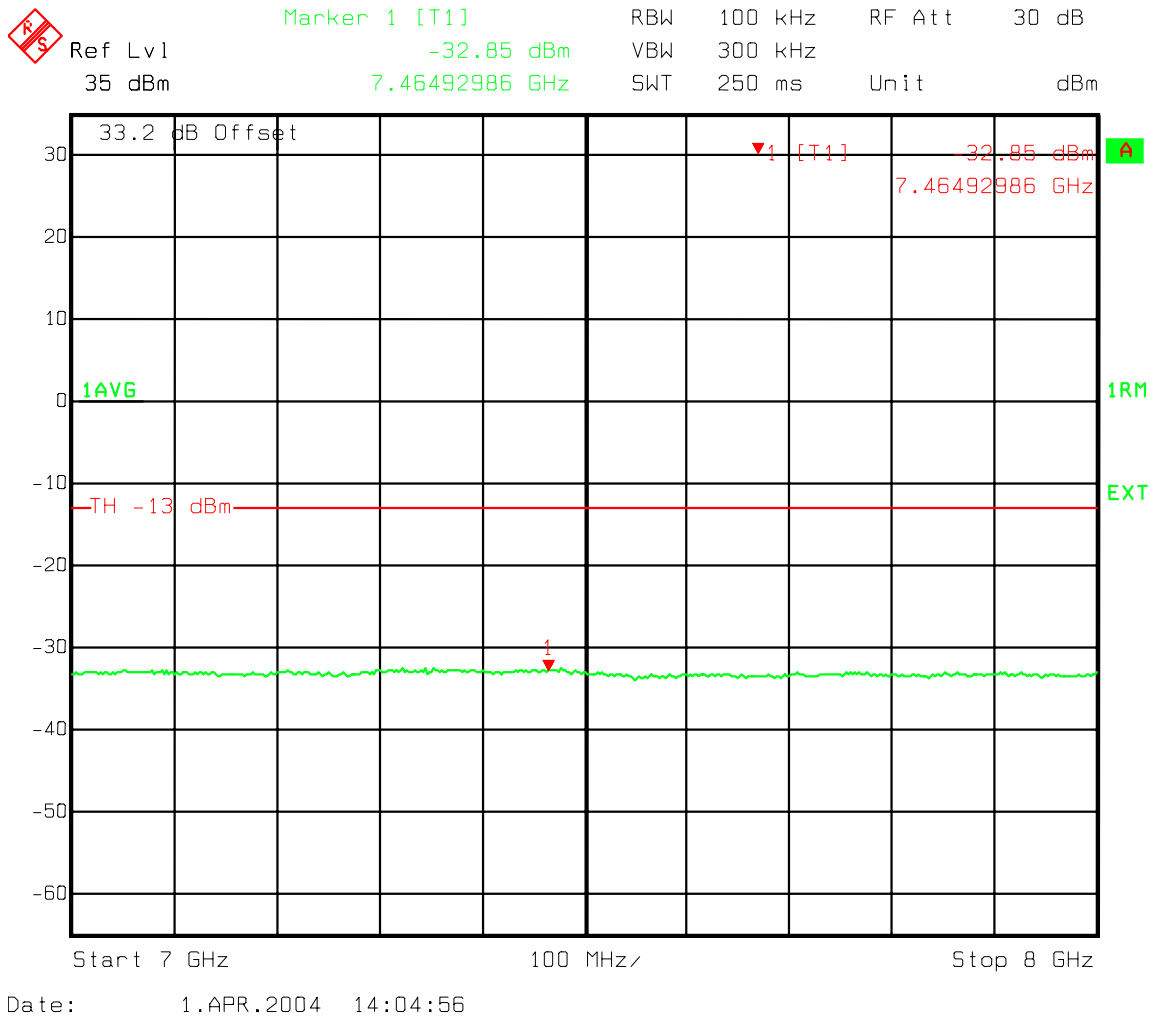

**Figure 135 : Combined Three Carriers - B Band 2-IS856/1-IS95 Spurious emissions 7000-8000 MHz**

**Combination Three Carrier 358 and 399 (IS856), 440 (IS95) Spurious Emissions at the 800 MHz MFRM-Maple Ant. Port band B**

**B Band IS856/IS95 Spurious emissions 8000-9000 MHz**

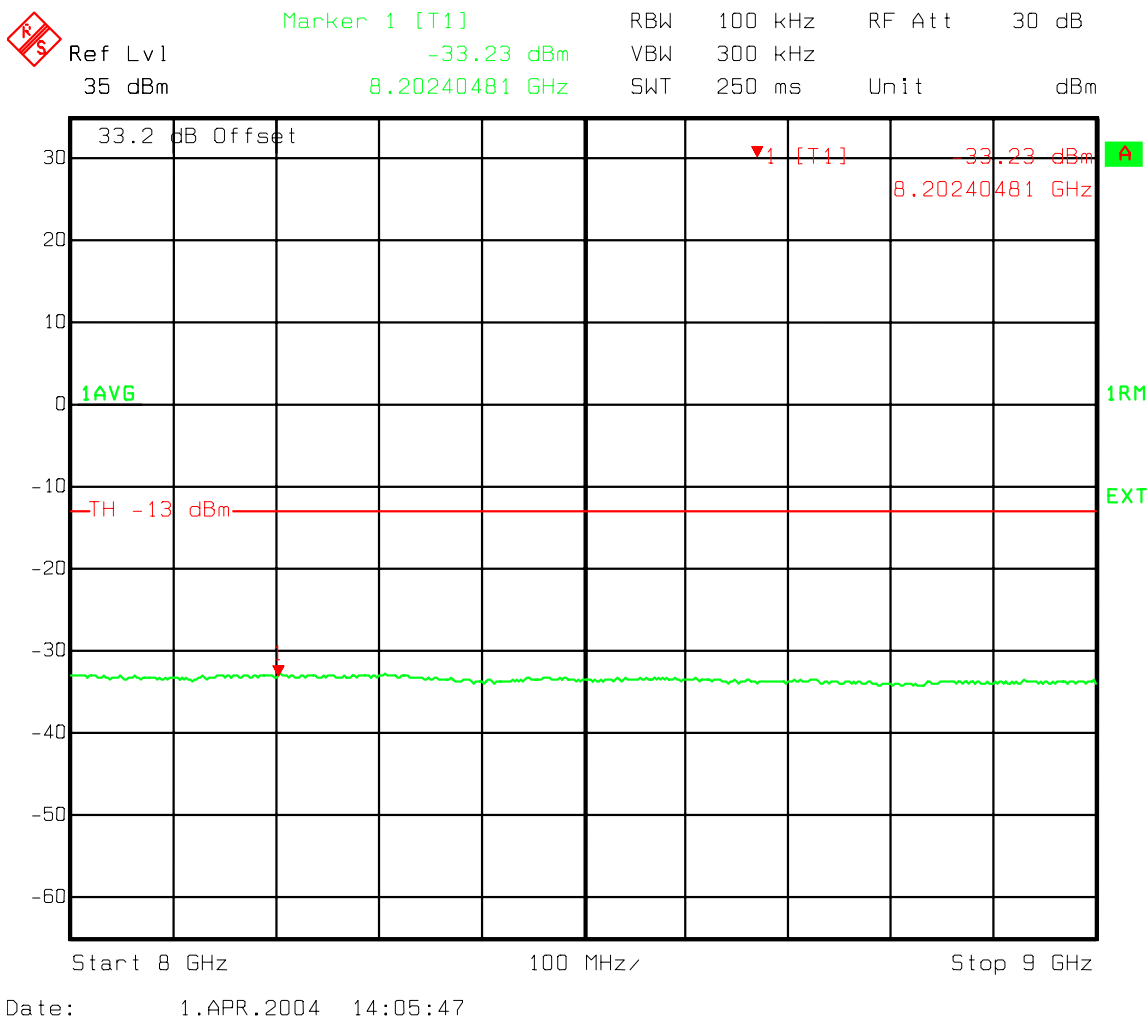

**Figure 136 : Combined Three Carriers - B Band 2-IS856/1-IS95 Spurious emissions 8000-9000 MHz**

**Combination Three Carrier 358 and 399 (IS856), 440 (IS95) Spurious Emissions at the 800 MHz MFRM-Maple Ant. Port band B**

**B Band IS856/IS95 Spurious emissions 9000-10000 MHz**

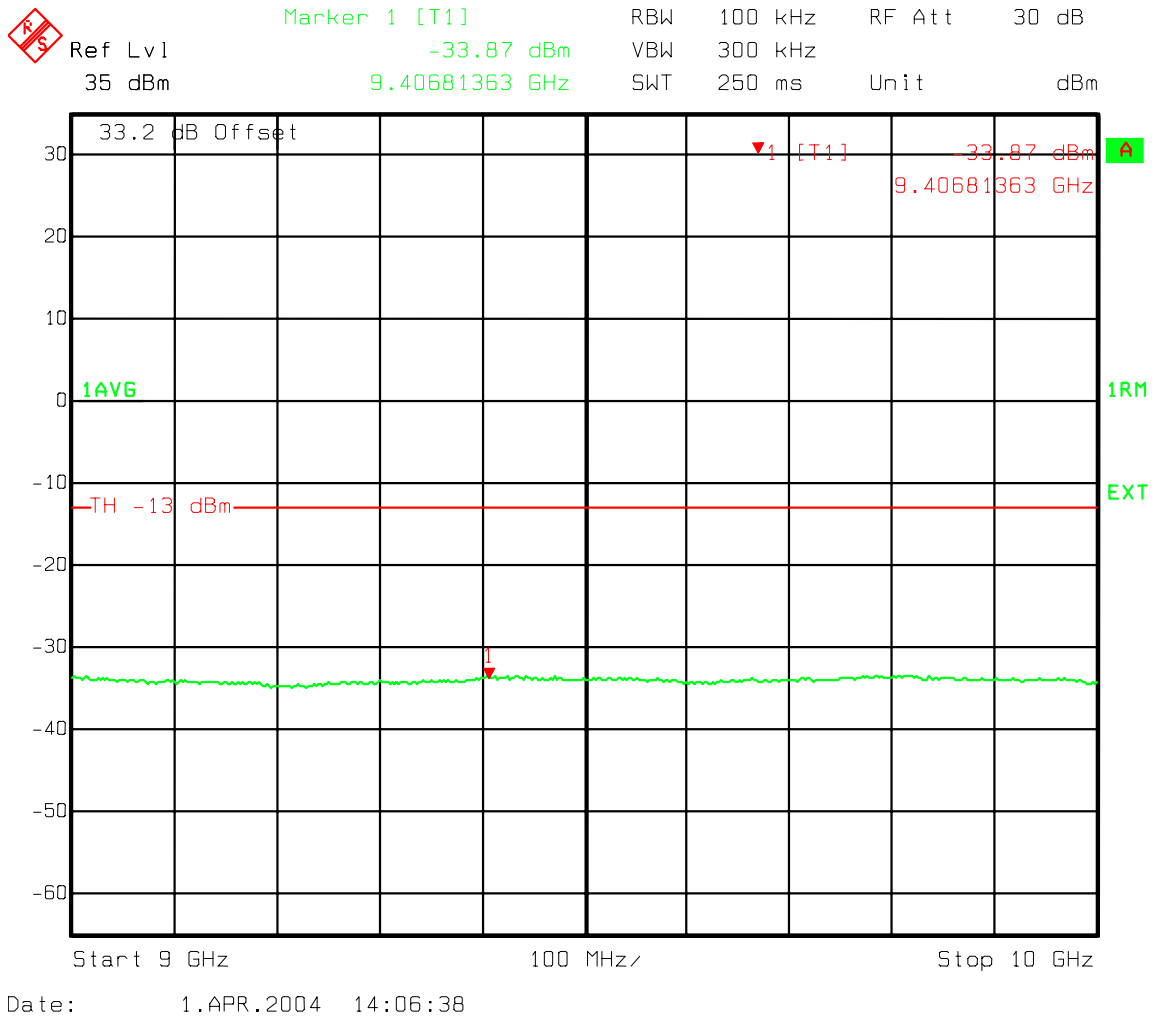

**Figure 137 : Combined Three Carriers - B Band 2-IS856/1-IS95 Spurious emissions 9000-10000 MHz**



---

## References

- [1] FCC Part 22 Subpart H, “Public Mobile Services”, [http://www.access.gpo.gov/nara/cfr/waisidx\\_01/47cfr22\\_01.html](http://www.access.gpo.gov/nara/cfr/waisidx_01/47cfr22_01.html)
- [2] FCC Part 2 Subpart J, “Frequency allocations and radio treaty matters; general rules and regulations”, [http://www.access.gpo.gov/nara/cfr/waisidx\\_01/47cfr2\\_01.html](http://www.access.gpo.gov/nara/cfr/waisidx_01/47cfr2_01.html)
- [3] Industry Canada RSS-129, “800 MHz Dual-Mode CDMA Cellular Telephones”, <http://strategis.ic.gc.ca/SSG/sf01324e.html>
- [4] TIA/EIA-97-D “Recommended Minimum Performance Standards for Base Stations Supporting Dual Mode Spread Spectrum Systems”, June 2001
- [5] Industry Canada “Information on the 99% Bandwidth measurement” Author Brian Kasper. [http://strategis.ic.gc.ca/epic/internet/inceb-bhst.nsf/vwapj/occupied-bandwidth.pdf/\\$FILE/occupied-bandwidth.pdf](http://strategis.ic.gc.ca/epic/internet/inceb-bhst.nsf/vwapj/occupied-bandwidth.pdf/$FILE/occupied-bandwidth.pdf)
- [6] TP\_AB6NT800MFRM2\_8\_and\_9th\_carrier. [http://livelink-ott.ca.nortel.com/livelink.exe/8153812/FCC\\_22\\_8th\\_and\\_9th\\_carrier\\_Test\\_Plan.pdf?func=doc.Fetch&node-did=8153812](http://livelink-ott.ca.nortel.com/livelink.exe/8153812/FCC_22_8th_and_9th_carrier_Test_Plan.pdf?func=doc.Fetch&node-did=8153812)

END OF DOCUMENT