



Test Report for FCC Equipment Authorization

FCC ID : AB6NT800MFRM CDMA Metro Cell 800MHz

Document:	TR_AB6NT800MFRM
Stream:	01
Issue:	01
Document Status:	Approved
Issue Date:	May 30, 2003
Security Status:	Nortel Networks Confidential
Author:	Fabian Wong

© 2001 Nortel Networks Limited

Disclaimer

The master of this document is stored on an electronic database and "write protected". The protection can be altered by authorized persons only. Viewing of the master document electronically ensures access to the current issue. Any hardcopies must be regarded as uncontrolled copies.

Security Warning

The information disclosed herein is proprietary to Nortel Networks and not to be used by or disclosed by unauthorized persons without the written consent of Nortel Networks. The recipient of this document shall respect the security status of the information.

PAGE INTENTIONALLY LEFT BLANK

Publication History

The latest controlled release of this document is located in an electronic database. **All other soft and hard copies are uncontrolled.** It is the responsibility of the reader to ensure that the latest release of this document is being used.

List of Consultants

The following people have reviewed this document prior to its release and have recommended its approval:

Printed Name	Function	Department
Kathleen Neild	CDMA RF Systems	2U41
Thomas Wong	Regulatory Prime	2U40

Decision Maker/Ratifier

The release of this document has been reviewed and approved for distribution and use by the following:

Ratifier's Name	Signature	Date
Brad Carlson		

Revision History

Stream/issue	Revision Date	Reason for Change	Author

Change bars are not used in this document.

Table of Contents

Publication History	3
List of Consultants	3
Decision Maker/Ratifier	3
Revision History	3
Acronyms and Abbreviations	11
1 Introduction.....	13
1.1 Test Result Summary	13
2 Engineering Declaration.....	14
3 Equipment Authorization Application Requirements	15
3.1 Standard Test Conditions and Test Equipment.....	15
3.2 EUT Identification List.....	15
3.3 Test Equipment List.....	15
4 Transmitter Test and Measurement Results.....	17
4.1 RF Power Output	17
4.1.1 RF Power Output Requirements	17
4.1.2 Test Method	17
4.1.3 Test Setup	17
4.1.4 Test Results	18
4.2 Occupied Bandwidth.....	19
4.2.1 Occupied Bandwidth Requirements	19
4.2.2 Test Method	19
4.2.3 Test Setup	20
4.2.4 Test Results.....	20
4.3 Spurious Emissions at Antenna Terminals	25
4.3.1 Spurious Emissions Requirements.....	25
4.3.2 Test Method	25
4.3.3 Test Setup	26
4.3.4 Test Results.....	27
4.4 Frequency Stability	52
4.4.1 Frequency Stability Requirements.....	52
4.4.2 Results.....	53
References.....	55

List of Tables

Table 1 : Test Results Summary	13
Table 2 : EUT Identification List.....	15
Table 3 : Test Equipment List.....	16
Table 4 : RF Output Power of 800 MHz MFRM, 1 Carrier Mode.....	18
Table 5 : RF Output Power of 800 MFRM, 2 Carrier Mode.....	18
Table 6 : RF Output Power 800 MFRM, 3 Carrier Mode	19
Table 7 : Occupied Bandwidth, 800 MFRM, Single Carrier Mode	20
Table 8 : Occupied Bandwidth, 800 MFRM 2 Carrier Mode.....	21
Table 9 : Occupied Bandwidth, 800 MFRM 3 Carrier Mode.....	21
Table 10 : Spurious Emissions at the 800 MHz MFRM Antenna Port - 1carrier.....	27
Table 11 : Spurious Emissions at the 800 MHz MFRM Antenna Port -2 carriers	28
Table 12 : Spurious Emissions at the 800 MHz MFRM Antenna Port -3 carriers	28

List of Figures

Figure 1 : Test Setup for RF Power Output Measurement	18
Figure 2 : Test Setup for Occupied Bandwidth Measurement.....	20
Figure 3 : Occupied Bandwidth - Single Carrier, Channel 17.....	22
Figure 4 : Occupied Bandwidth - 2 Carrier, Channel 17, 58.....	23
Figure 5 : Occupied Bandwidth - 3 Carrier, Channel 534, 575, 616.....	24
Figure 6 : Test Setup for Spurious Emissions Measurement.....	26
Figure 7 : Conducted Spurious Emissions - 1 Carrier, Channel 17 (Lower adjacent 1 MHz)	30
Figure 8 : Conducted Spurious Emissions - 1 Carrier, Channel 283 (Upper adjacent 1 MHz).....	31
Figure 9 : Conducted Spurious Emissions - 1 Carrier, Channel 17 (400 MHz - 1 GHz).....	32
Figure 10 : Conducted Spurious Emissions - 1 Carrier, Channel 17 (1 GHz - 2 GHz).....	33
Figure 11 : Conducted Spurious Emissions - 1 Carrier, Channel 17 (2 GHz - 3 GHz).....	34
Figure 12 : Conducted Spurious Emissions - 1 Carrier, Channel 17 (3 GHz - 4 GHz).....	35
Figure 13 : Conducted Spurious Emissions - 1 Carrier, Channel 17 (4 GHz - 5 GHz).....	36
Figure 14 : Conducted Spurious Emissions - 1 Carrier, Channel 17 (5 GHz - 6 GHz).....	37
Figure 15 : Conducted Spurious Emissions - 1 Carrier, Channel 17 (6 GHz - 7 GHz).....	38
Figure 16 : Conducted Spurious Emissions - 1 Carrier, Channel 17 (7 GHz - 8 GHz).....	39
Figure 17 : Conducted Spurious Emissions - 1 Carrier, Channel 17 (8 GHz - 9GHz).....	40
Figure 18 : Conducted Spurious Emissions - 3 Carrier, Channels 17, 58, 99 (Lower adjacent 1 MHz).....	41
Figure 19 : Conducted Spurious Emissions - 3 Carrier, Channels 201, 242, 283 (Upper adjacent 1 MHz).....	42
Figure 20 : Conducted Spurious Emissions - 3 Carrier, Chans 17, 58, 99 (400MHz-1 GHz)	43
Figure 21 : Conducted Spurious Emissions - 3 Carrier, Channels 17, 58, 99 (1 - 2GHz).....	44
Figure 22 : Conducted Spurious Emissions - 3 Carrier, Channels 17, 58, 99 (2 - 3 GHz).....	45
Figure 23 : Conducted Spurious Emissions - 3 Carrier, Channels 17, 58, 99 (3 - 4 GHz).....	46
Figure 24 : Conducted Spurious Emissions - 3 Carrier, Channels 17, 58, 99 (4 - 5GHz).....	47
Figure 25 : Conducted Spurious Emissions - 3 Carrier, Channels 17, 58, 99 (5 - 6GHz).....	48
Figure 26 : Conducted Spurious Emissions - 3 Carrier, Channels 17, 58, 99 (6 - 7GHz).....	49
Figure 27 : Conducted Spurious Emissions - 3 Carrier, Channels 17, 58, 99 (7 - 8GHz).....	50
Figure 28 : Conducted Spurious Emissions - 3 Carrier, Channels 17, 58, 99 (8 - 9GHz).....	51

Acronyms and Abbreviations

ASIC	Application Specific Integrated Circuit
BBW	Breathing, Blossoming and Wilting
BPF	Bandpass Filter
BTS	Base Station Transceiver Subsystem
BW	Bandwidth
CDMA	Code Division Multiple Access
dBFS	dB relative to Full Scale
DDS	Direct Digital Synthesizer
DPM	Duplexer Preselector Module
EEPROM	Electrically Erasable and Programmable ROM
EC	Engineering Change
ERLCE	Excess Reverse Link Capacity Estimate
HSSPC	High-Speed Serial Protocol Controller
HW	Hardware
IF	Intermediate Frequency
IIC	Inter-Integrated Circuit Bus
IS	Interim Standard
LO	Local Oscillator
LPF	Lowpass Filter
MCPA	Multi-Carrier Power Amplifier
MFRM	Multi-carrier Flexible Radio Module
NF	Noise Figure
OCNS	Orthogonal Channel Noise Source
OH	OverHead
PA	Power Amplifier
PC	Personal Computer
PPR	Peak Power Reduction
PSA	Product Specification Agreement
RBW	Resolution BandWidth
RF	Radio Frequency

Rx	Receive
SA	Spectrum Analyzer
SFRM	Single Carrier Flexible Radio Module
SW	Software
TBD	To Be Determined
TM	Triplexer Module
TPTL	Transmit Power Tracking Loop
TRM	Transmitter Receiver Module
Tx	Transmit
uP	Microprocessor
XCVR	Transceiver

1 Introduction

This test report is submitted in accordance with the FCC Rules and Regulations, Part 2, Subpart J, Sections 2.1046 through 2.1057 for equipment authorization of Northern Telecom's (Nortel Networks) CDMA 800 MHz Multiple carrier Flexible Radio Module (MFRM).

The 800 MHz MFRM is intended for use in the Domestic Public Cellular Radio Telecommunications Service and is designed in accordance with the following standards:

- *CFR 47, Part 22, Subpart H, Cellular Radiotelephone Service [1]*
- *CFR 47, Part 2, Subpart J, Equipment Authorization Procedures - Equipment Authorization[2]*

1.1 Test Result Summary

Table 1 summarizes the measurement results¹ for the CDMA 800MHz MFRM.

Table 1 : Test Results Summary

FCC Measurement Specification	FCC Limit Specification	Description	Results
2.1046		RF Power Output	
2.1047		Modulation Characteristics	Not Applicable
2.1049		Occupied Bandwidth	
2.1051, 2.1057	22.917	Spurious Emissions at Antenna Terminals	Compliant
2.1055	22.355	Frequency Stability	Compliant

1. This report presents measurement results for tests performed by Nortel Networks. Field Strength of Spurious Emissions measurement results along with requirements specified in 2.1033 are covered in a separate test report from Sanmina Canada.

2 Engineering Declaration

The CDMA 800MHz Multi carrier Flexible Radio Module has been tested in accordance with the requirements contained in the Federal Communications Commission Rules and Regulations Part 2 and 22.

To the best of my knowledge, these tests were performed in accordance with good engineering practices using measurement procedures consistent with industry or commission standards or previous Commission correspondence or guidance and demonstrate that this equipment complies with the appropriate standards. All tests were conducted on a representative sample of the equipment for which equipment authorization is sought.

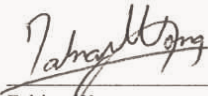
Tested By:

Fabian Wong
Production Design Control
Nortel Networks
Calgary, Canada

MAY 16, 2003

Date

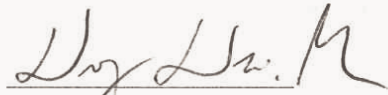
Reviewed By:

Thomas Wong
Regulatory Prime
Nortel Networks
Calgary, Canada

May 16, 2003

Date

Approved By:

Brad Carlson
Production Design Control
Manager
Nortel Networks
Calgary, Canada

MAY 16, 2003

Date

3 Equipment Authorization Application Requirements

3.1 Standard Test Conditions and Test Equipment

The MFRM was tested under the following standard test conditions unless otherwise noted:

- Ambient Temperature: 20 to 35 degrees C
- Ambient Humidity: 20 to 40%
- DC Supply Voltage: -48 Vdc (nominal)

3.2 EUT Identification List

Table 2 shows the identification of the components tested in this report.

Table 2 : EUT Identification List

Equipment Description	Model / Part Number	Release Number	Serial Number
800 MHz Multiple carrier Flexible Radio Module (comprised of the main modules below)	N/A	N/A	N/A
a) 800 MHz MTRM	NTGY10CA	MC	NNTM538CW840
b) 800 MHz MPAM	NTGY70AB	69	NNTM532RXNWF
c) 800 MHz A Band DPM	NTGS89DD	N/A	QUALA2
d) 800 MHz B Band DPM	NTGS89DF	N/A	QUAL2B

3.3 Test Equipment List

Table 3 shows the identification of the test equipment used in this report.

Table 3 : Test Equipment List

Description	Manufacturer	Model	Serial Number	Cal. Due Date
20Hz to 26.5 GHz Spectrum Analyzer	Rohde&Schwarz	FSEM	827602/003	Nov 01,2003
RF Power Meter	Agilent	EPM-442A	US37480486	May 08, 2004
RF Power Sensor Head	Agilent	8481A	3318A99987	May 22, 2004
30dB Attenuator	Weinschel Corp.	48-30-43	BJ6055	N/A
10 dB Attenuator	Bird	25-A-MFN-10	9741	N/A
RF Cable	Micro-Coax	FSCM 64639	97D0232	N/A

4 Transmitter Test and Measurement Results

4.1 RF Power Output

4.1.1 RF Power Output Requirements

FCC Part 2.1046

(a) For transmitters other than single sideband, independent sideband and controlled carrier radiotelephone, power output shall be measured at the RF output terminals when the transmitter is adjusted in accordance with the tune -up procedure to give the values of current and voltage on the circuit elements specified in 2.983(d)(5). The electrical characteristics of the radio frequency load attached to the output terminals when this test is made shall be stated.

(c) For measurements conducted pursuant to paragraphs (a) and (b) of this section, all calculations and methods used by the applicant for determining carrier power or peak envelope power, as appropriate, on the basis of measured power in the radio frequency load attached to the transmitter output terminals shall be shown. Under the test conditions specified, no components of the emission spectrum shall exceed the limits specified in the applicable rule parts as necessary for meeting occupied bandwidth or emission limitations.

4.1.2 Test Method

The DE was setup via the BTS controller to enable the MFRM to transmit at maximum power. Measurements were made in one, two, and three carrier configurations. The RF output power was measured using the power meter.

4.1.3 Test Setup

The set-up used for the MFRM RF output power test is illustrated in Figure 1. RF output power measurements were referenced to the antenna port of the DPM.

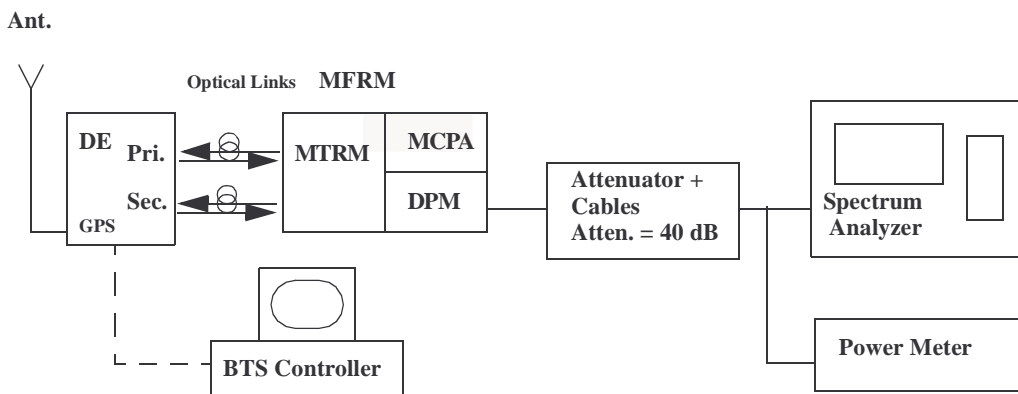

Figure 1 : Test Setup for RF Power Output Measurement

4.1.4 Test Results

The 800 MHz MFRM complies with the requirement. The average maximum rated RF output power from the MFRM is 47.3 dBm.

Table 4 : RF Output Power of 800 MHz MFRM, 1 Carrier Mode

Channel Number (Band)	Frequency (MHz)	Measured Max. RF Output Power (dBm)	Average Max. Rated RF Output Power (dBm)
17 (A)	870.51	47.35	47.3
283 (A)	878.49	47.34	47.3
384 (B)	881.52	47.21	47.3
616 (B)	888.48	47.26	47.3

Table 5 : RF Output Power of 800 MFRM, 2 Carrier Mode

Channel Number (Band)	Frequency (MHz)	Measured Max. RF Output Power (dBm)	Average Max. Rated RF Output Power (dBm)
17, 58 (A)	870.51, 871.74	47.38	47.3
242, 283 (A)	877.26, 878.49	47.40	47.3

Table 6 : RF Output Power 800 MFRM, 3 Carrier Mode

Channel Number (Band)	Frequency (MHz)	Measured Max. RF Output Power (dBm)	Average Max. Rated RF Output Power (dBm)
17, 58, 99 (A)	870.51, 871.74, 872.97	47.42	47.3
201, 242, 283 (A)	876.03, 877.26, 878.49	47.28	47.3
384, 425, 466 (B)	881.52, 882.75, 883.98	47.29	47.3
534, 575, 616 (B)	882.02, 883.25, 888.48	47.36	47.3

4.2 Occupied Bandwidth

4.2.1 Occupied Bandwidth Requirements

FCC Part 2.1049

The OBW, that is the frequency bandwidth such that, below its lower and above its upper frequency limits, the mean powers radiated are each equal to 0.5 percent of the total mean power radiated by a given emission shall be measured under the following conditions as applicable:

(g) Transmitter in which the modulating baseband comprises not more than three independent channels - when modulated by the full complement of signals for which the transmitter is rated. The level of modulation for each channel should be set to that prescribed in rule parts applicable to the services for which the transmitter is intended. If specific modulation levels are not set forth in the rules, the tests should provide the manufacturer's maximum rated condition.

(h) Transmitters employing digital modulation techniques - when modulated by an input signal such that its amplitude and symbol rate represent the maximum rated conditions under which the equipment will be operated. The signal shall be applied through any filter networks, pseudo-random generators or other devices required in normal service. Additionally, the occupied bandwidth shall be shown for operation with any devices used for modifying the spectrum when such devices are optional at discretion of the user.

4.2.2 Test Method

The DE was setup via the BTS controller to enable the MFRM to transmit at maximum power. The occupied bandwidth was measured using the 99% channel power feature of the spectrum analyzer.

4.2.3 Test Setup

The set-up used for the MFRM Occupied bandwidth test is illustrated in Figure 2.

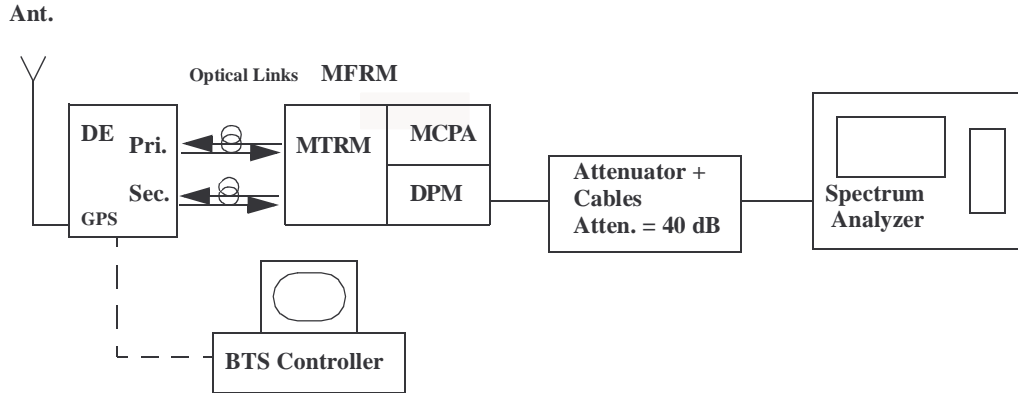

Figure 2 : Test Setup for Occupied Bandwidth Measurement

4.2.4 Test Results

The 800 MHz MFRM complies with the requirement. The occupied bandwidth measured in one, two, and three carrier configurations for each licensed band is shown in Table 7. The plots that follow show the occupied bandwidth in one, two, and three carrier configurations. (Although plots were recorded for all channels tested, only one sample plot per carrier configuration is provided reduce the number of figures).

Table 7 : Occupied Bandwidth, 800 MFRM, Single Carrier Mode

Channel Number (Band)	Frequency (MHz)	Measured Occupied Bandwidth (kHz)
17 (A)	870.51	1254.5
283 (A)	878.49	1251.0
384 (B)	881.52	1251.0
616 (B)	888.48	1262.5

Table 8 : Occupied Bandwidth, 800 MFRM 2 Carrier Mode

Channel Number (Band)	Frequency (MHz)	Measured Occupied Bandwidth (kHz)
17, 58 (A)	870.51, 871.74	2464.929
242, 283 (A)	877.26, 878.49	2515.030

Table 9 : Occupied Bandwidth, 800 MFRM 3 Carrier Mode

Channel Number (Band)	Frequency (MHz) (centre channel)	Measured Occupied Bandwidth (kHz)
17, 58, 99 (A)	870.51, 871.74, 872.97	3717.434
201, 242, 283 (A)	876.03, 877.26, 878.49	3717.434
384, 425, 466 (B)	881.52, 882.75, 883.98	3689.378
534, 575, 616 (B)	882.02, 883.25, 888.48	3671.342

Figure 3 : Occupied Bandwidth - Single Carrier, Channel 17

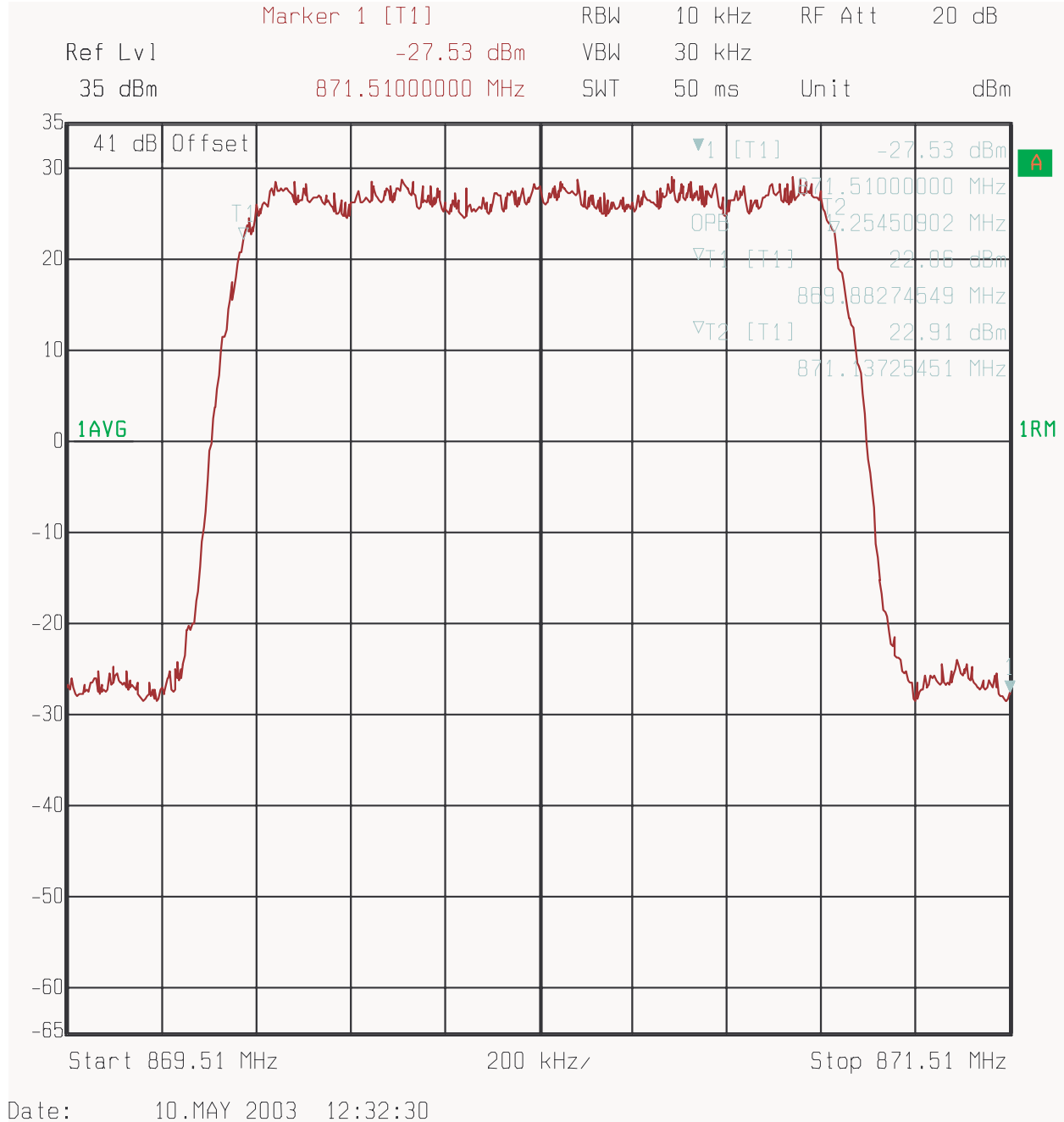

Figure 4 : Occupied Bandwidth - 2 Carrier, Channel 17, 58

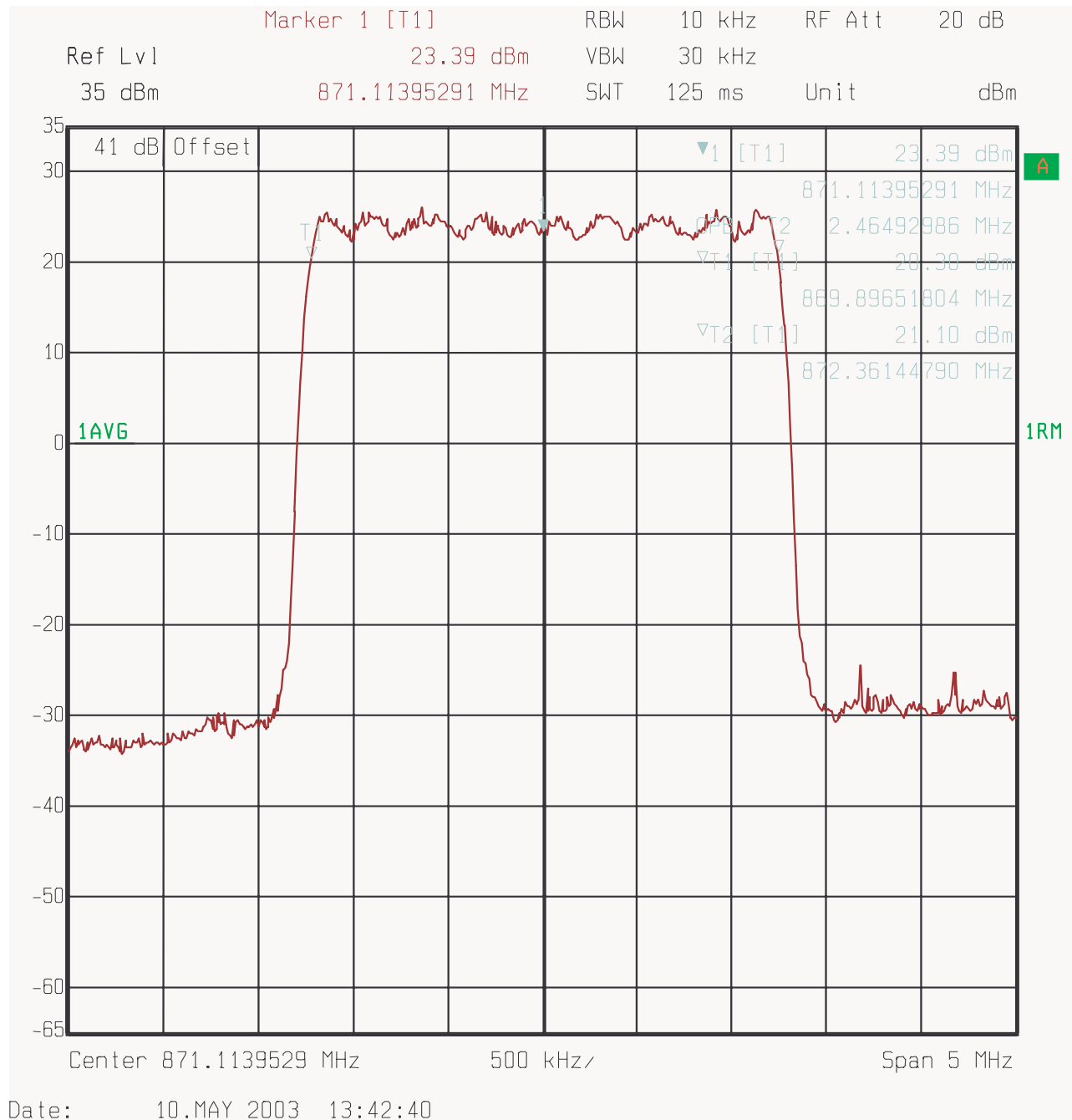
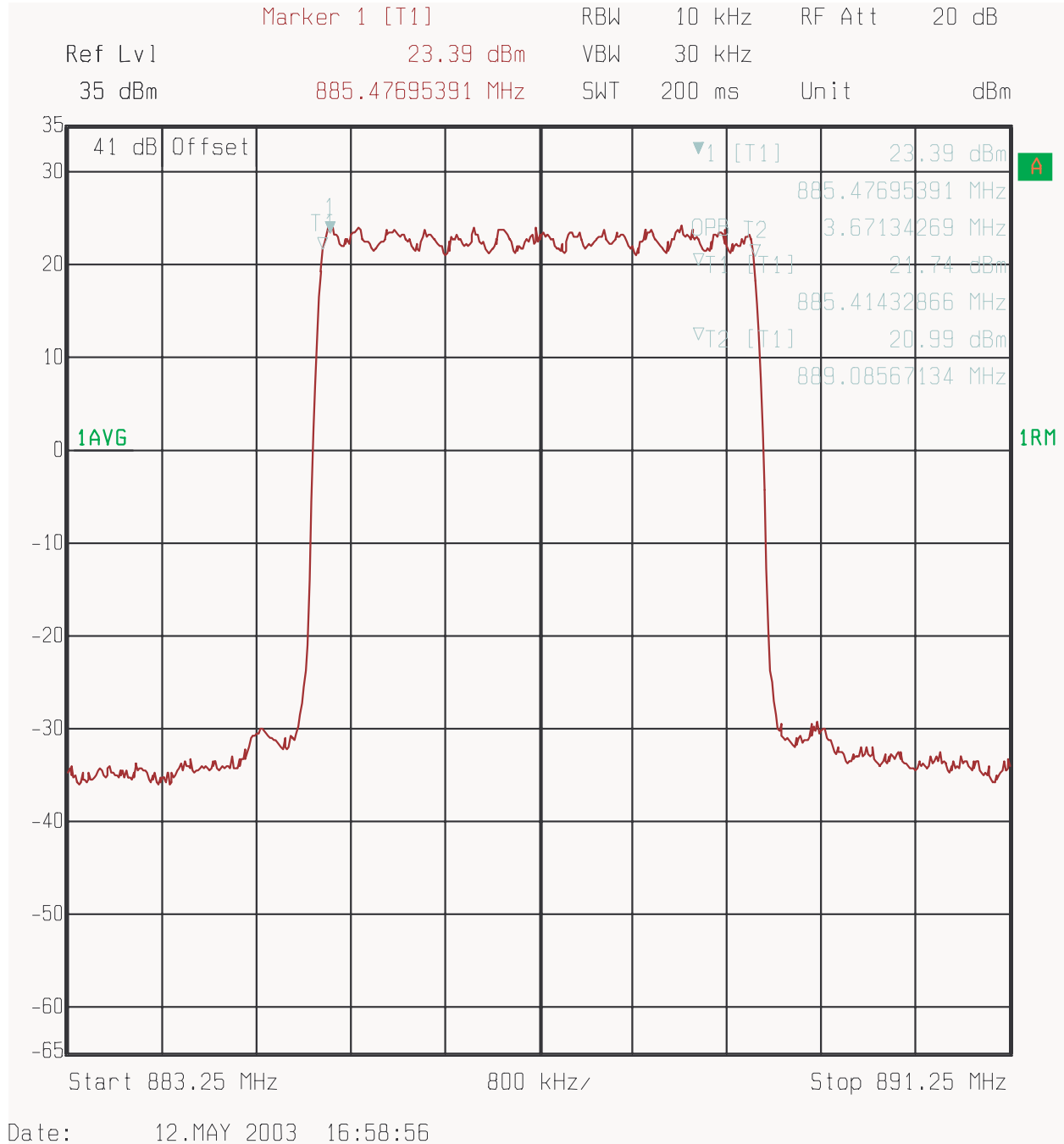

Figure 5 : Occupied Bandwidth - 3 Carrier, Channel 534, 575, 616



4.3 Spurious Emissions at Antenna Terminals

4.3.1 Spurious Emissions Requirements

FCC Part 2.1051

The radio frequency voltage or powers generated within the equipment and appearing on a spurious frequency shall be checked at the equipment output terminals when properly loaded with a suitable artificial antenna. Curves or equivalent data shall show the magnitude of each harmonic and other spurious emission that can be detected when the equipment is operated under the conditions specified in 2.1049 as appropriate. The magnitude of spurious emissions which are attenuated more than 20 dB below the permissible value need not be specified.

FCC Part 2.1057 - Frequency Spectrum to be investigated

The spectrum should be investigated from the lowest radio frequency generated in the equipment up to at least the 10th harmonic of the carrier frequency or to the highest frequency practicable in the present state of the art of measuring techniques, whichever is lower. Particular attention should be paid to harmonics and subharmonics of the carrier frequency. Radiation at the frequencies of multiplier stages should be checked. The amplitude of spurious emissions which are attenuated more than 20 dB below the permissible value need not be reported.

FCC Part 22.917 Limit

Out of band emissions. The power of any emission outside of the authorized operating frequency ranges must be attenuated below the transmitting power (P) by a factor of at least $43 + 10 \log(P)$ dB.

Measurement procedure. Compliance with these rules is based on the use of measurement instrumentation employing a resolution bandwidth of 100 kHz or greater. In the 1MHz bands immediately outside and adjacent to the frequency block a resolution bandwidth of at least one percent of the emission bandwidth of the fundamental emission of the transmitter may be employed. A narrower resolution bandwidth is permitted in all cases to improve measurement accuracy provided the measured power is integrated over the full required measurement bandwidth (i.e. 100 kHz or 1 percent of emission bandwidth, as specified). The emission bandwidth is defined as the width of the signal between two points, one below the carrier center frequency and one above the carrier center frequency, outside of which all emissions are attenuated at least 26 dB below the transmitter power.

4.3.2 Test Method

The BTS digital enclosure was configured via the BTS controller to enable the MFRM to transmit at maximum power. Measurements were made on channels at the bottom and top of the licensed sub-bands in one, two and three carrier configurations. The following spectrum analyzer settings

were used for the measurement of the antenna port spurious emissions:

Adjacent 1MHz to indicated cellular band (Upper and Lower)

Resolution Bandwidth:	30 kHz (1 carrier, 2 carrier), 50 kHz (3 carrier)
Video Bandwidth:	100 kHz (1 carrier, 2 carrier), 300 kHz (3 carrier)
Video Average:	10 Averages
Span:	1 MHz
Attenuation:	20 dB
Ref. Level:	35.0 dBm
Ref. Level Offset:	41.0 dB

All spectrum analyzer settings were coupled as per the manufacturers recommendations to improve measurement time, without compromising data.

All other Spurious Emissions up to 9 GHz

Resolution Bandwidth:	100 kHz (1 carrier, 2 carrier, 3 carrier)
Video Bandwidth:	300 kHz (1 carrier, 2 carrier, 3 carrier)
Video Average:	10 Averages
Span:	Set accordingly
Attenuation:	20 dB
Ref. Level:	35.0 dBm
Ref. Level Offset:	Vary depending on calibration

4.3.3 Test Setup

The set-up used for the MFRM Antenna Port Spurious Emission test is illustrated in Figure 6.

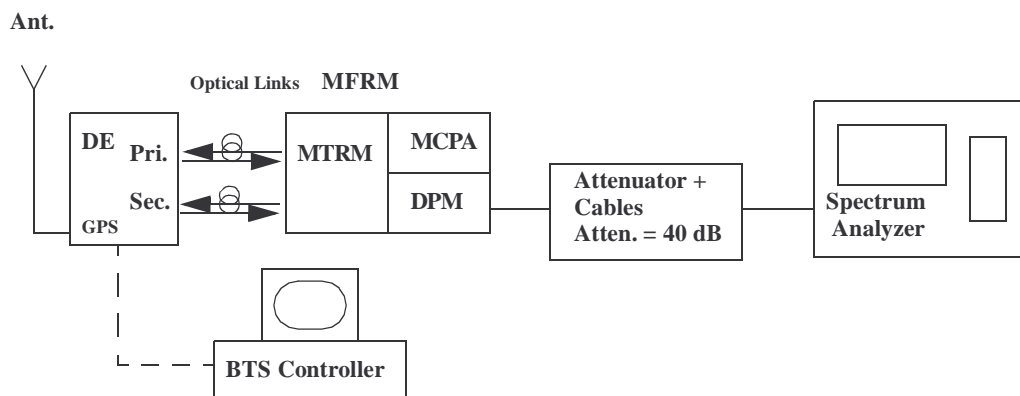

Figure 6 : Test Setup for Spurious Emissions Measurement

4.3.4 Test Results

The frequency spectrum from 1 MHz to 9 GHz was scanned for emissions using the spectrum analyzer settings outlined in the test method (Section 4.3.2). The MFRM complies with the limit of -13 dBm. Table 10 shows the spurious emissions at the antenna port of the MFRM for 1, 2 and 3 carrier modes. The plots that follow show the spurious emissions in one, two, and three carrier configuration. (For each configuration, only one sample is shown to reduce the number of figures).

Table 10 : Spurious Emissions at the 800 MHz MFRM Antenna Port - 1carrier

Frequency (MHz)	Spurious Emissions Level (dBm)	Margin to FCC Limit of -13 dBm (dB)
	1 carrier (30KHz RBW)	1 carrier
869 (lower edge of band A) Ch 17	-22.77	9.77
880 (upper edge of band A) Ch 283	-19.84	6.84
880 (lower edge of band B) Ch 384	-21.78	8.78
890(upper edge of band B) Ch 616	-20.34	7.34
50-1000 (RBW=100KHz) ^a	-18.41	5.41
1000 - 2000 (RBW=100KHz) ^a	-29.23	16.23
2000 - 3000 (RBW=100KHz) ^a	-37.00	24.00
3000 - 4000 (RBW=100KHz) ^a	-37.24	24.24
4000 - 5000 (RBW=100KHz) ^a	-37.43	24.43
5000 - 6000 (RBW=100KHz) ^a	-35.13	22.13
6000 - 7000 (RBW=100KHz) ^a	-33.15	20.15
7000 - 8000 (RBW=100KHz) ^a	-37.73	24.73
8000 - 9000 (RBW=100KHz) ^a	-36.15	23.15

Notes: ^a Emission levels given in these ranges represents the worst case value over all the tested channels

Table 11 : Spurious Emissions at the 800 MHz MFRM Antenna Port -2 carriers

Frequency (MHz)	Spurious Emissions Level (dBm)	Margin to FCC Limit of -13 dBm (dB)
	2 carrier (30 kHz RBW)	2 carriers
869 (lower edge of band A) Ch 17,58	-25.65	12.65
880 (upper edge of band A) Ch 242, 283	-22.11	9.11
50-1000 (RBW=100KHz) ^a	-20.34	7.34
1000 - 2000 (RBW=100KHz) ^a	-31.74	18.74
2000 - 3000 (RBW=100KHz) ^a	-37.81	24.81
3000 - 4000 (RBW=100KHz) ^a	-37.17	24.17
4000 - 5000 (RBW=100KHz) ^a	-37.53	24.53
5000 - 6000 (RBW=100KHz) ^a	-35.23	22.23
6000 - 7000 (RBW=100KHz) ^a	-33.25	20.25
7000 - 8000 (RBW=100KHz) ^a	-37.76	24.76
8000 - 9000 (RBW=100KHz) ^a	-36.04	23.04

Notes: ^a Emission levels given in these ranges represents the worst case value over all the tested channels

Table 12 : Spurious Emissions at the 800 MHz MFRM Antenna Port -3 carriers

Frequency (MHz)	Spurious Emissions Level (dBm)	Margin to FCC Limit of -13 dBm (dB)
	3 carriers (50 kHz RBW)	3 carriers
869 (lower edge of band A) Ch 17, 58, 99	-27.95	14.95
880 (upper edge of band A) Ch 201, 242, 283	-26.74	13.74
880 (lower edge of band B) Ch 384, 425, 466	-26.64	13.64
890(upper edge of band B) Ch 534, 575, 616	-25.45	12.45

Frequency (MHz)	Spurious Emissions Level (dBm)	Margin to FCC Limit of -13 dBm (dB)
	3 carriers (50 kHz RBW)	3 carriers
50-1000 (RBW=100KHz) ^a	-24.85	11.85
1000 - 2000 (RBW=100KHz) ^a	-32.50	19.50
2000 - 3000 (RBW=100KHz) ^a	-37.66	24.66
3000 - 4000 (RBW=100KHz) ^a	-37.08	24.08
4000 - 5000 (RBW=100KHz) ^a	-37.43	24.43
5000 - 6000 (RBW=100KHz) ^a	-35.08	22.08
6000 - 7000 (RBW=100KHz) ^a	-33.17	20.17
7000 - 8000 (RBW=100KHz) ^a	-37.59	24.59
8000 - 9000 (RBW=100KHz) ^a	-36.16	23.16

Notes: ^a Emission levels given in these ranges represents the worst case value over all the tested channels

Figure 7 : Conducted Spurious Emissions - 1 Carrier, Channel 17 (Lower adjacent 1 MHz)

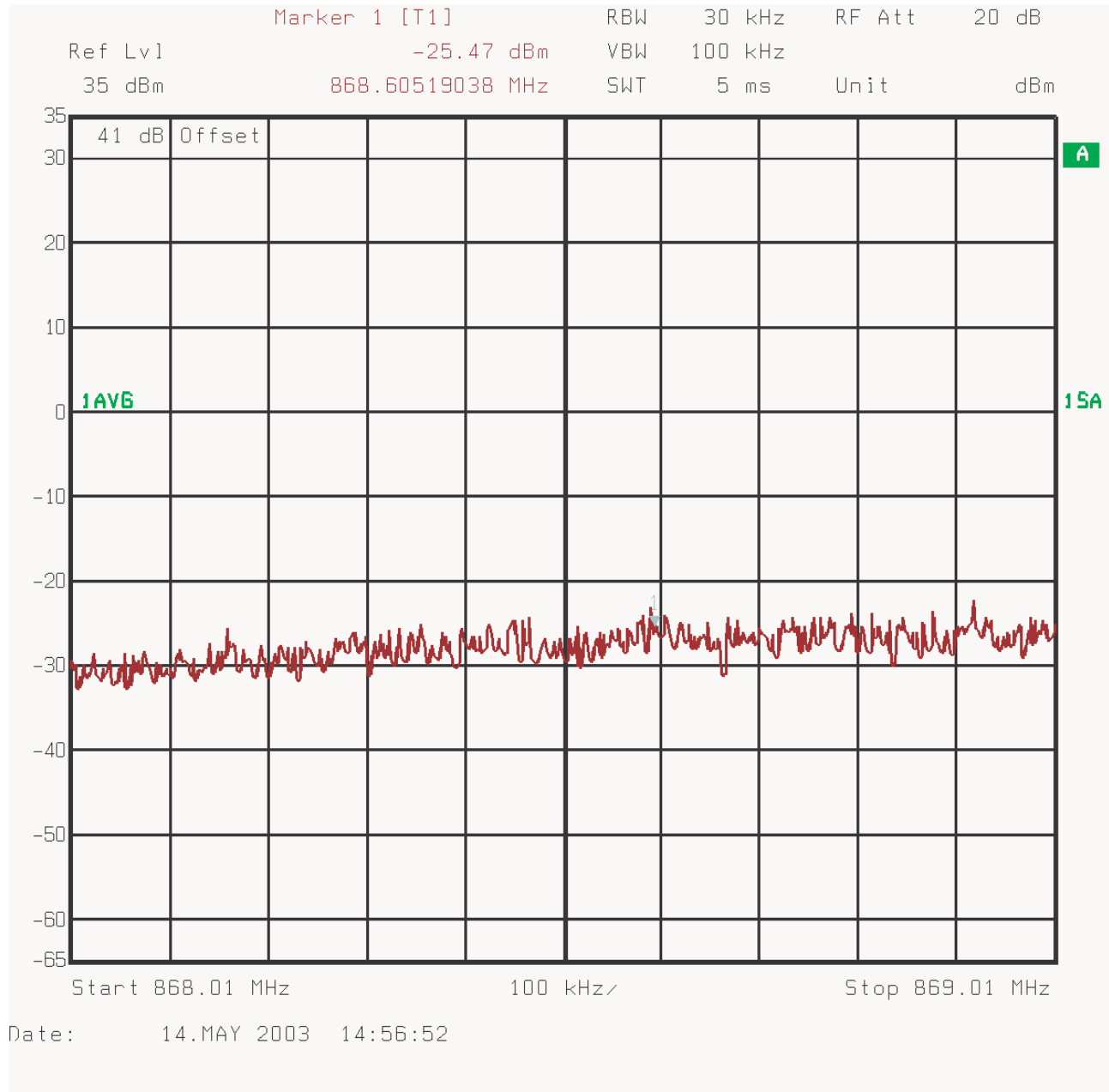

Figure 9 : Conducted Spurious Emissions - 1 Carrier, Channel 17 (400 MHz - 1 GHz)

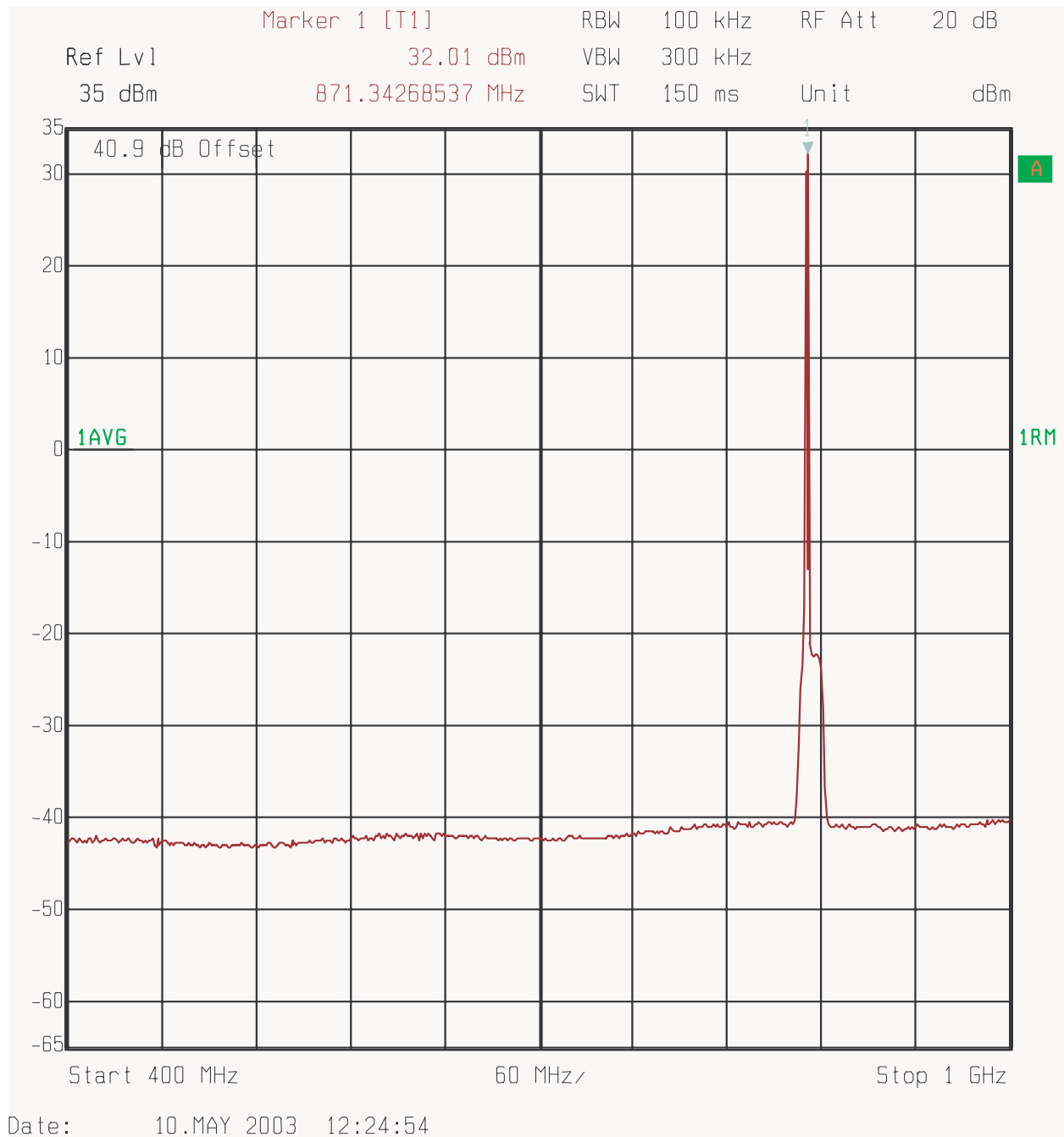

Figure 10 : Conducted Spurious Emissions - 1 Carrier, Channel 17 (1 GHz - 2 GHz)

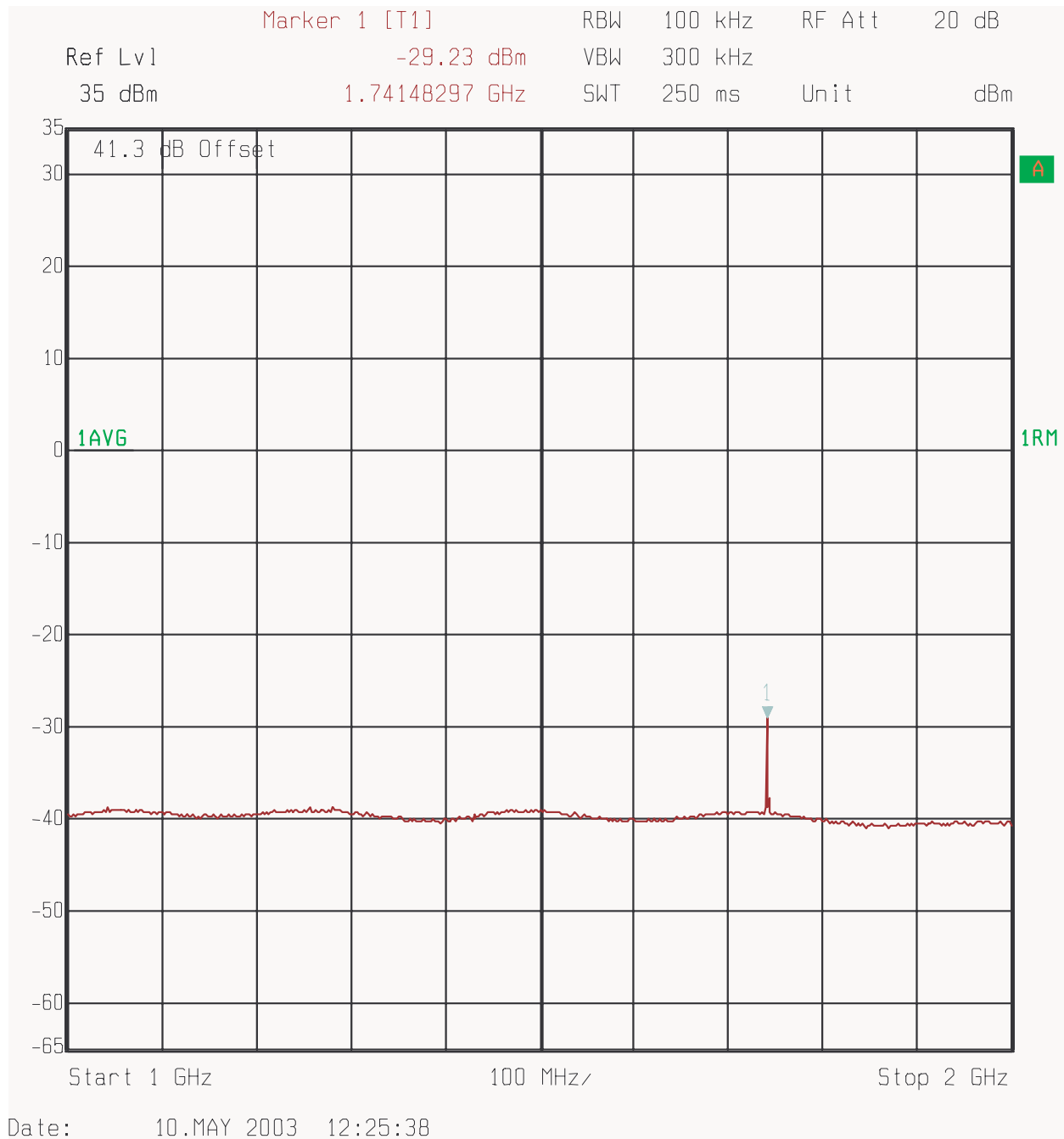

Figure 11 : Conducted Spurious Emissions - 1 Carrier, Channel 17 (2 GHz - 3 GHz)

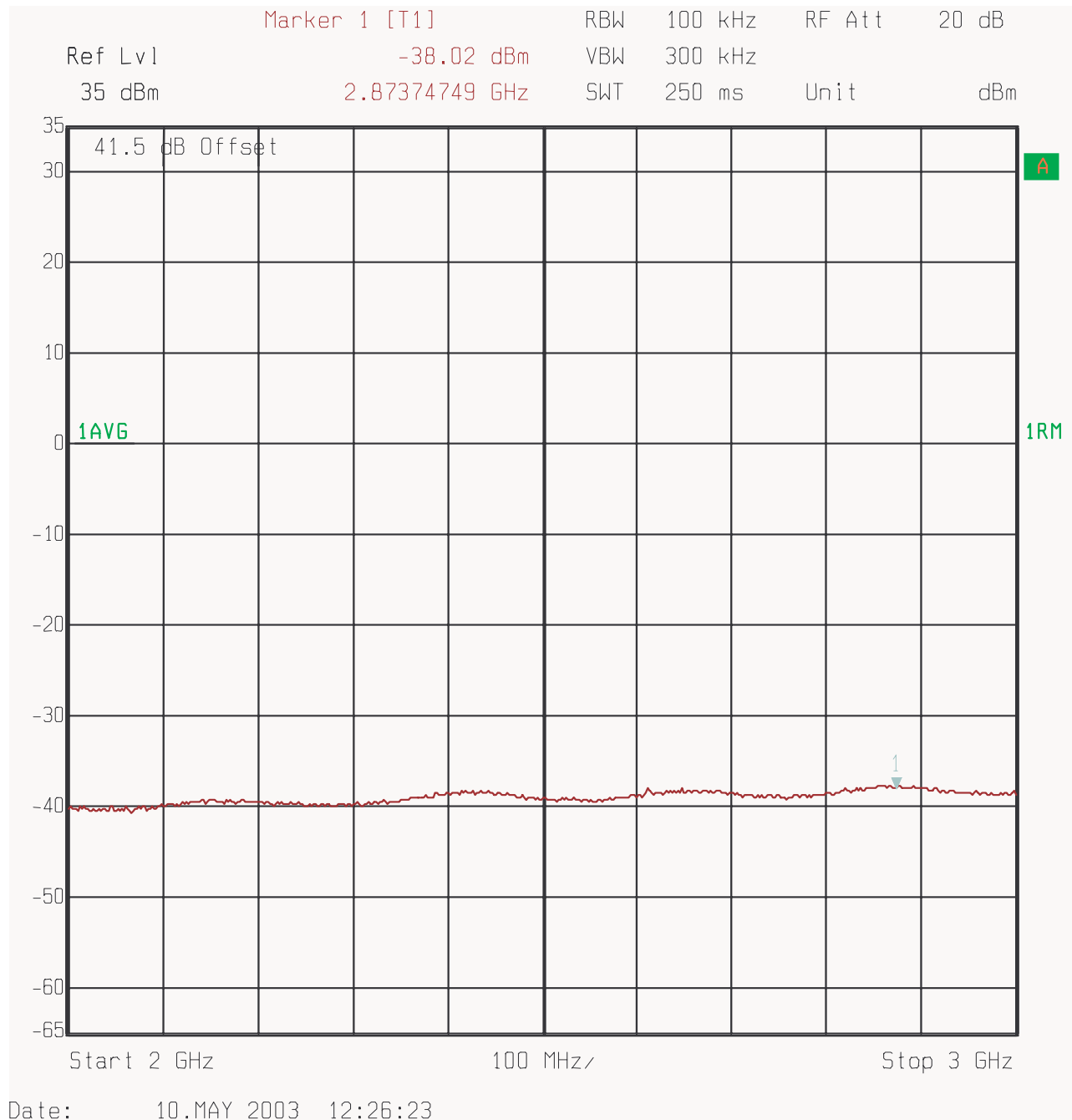

Figure 12 : Conducted Spurious Emissions - 1 Carrier, Channel 17 (3 GHz - 4 GHz)

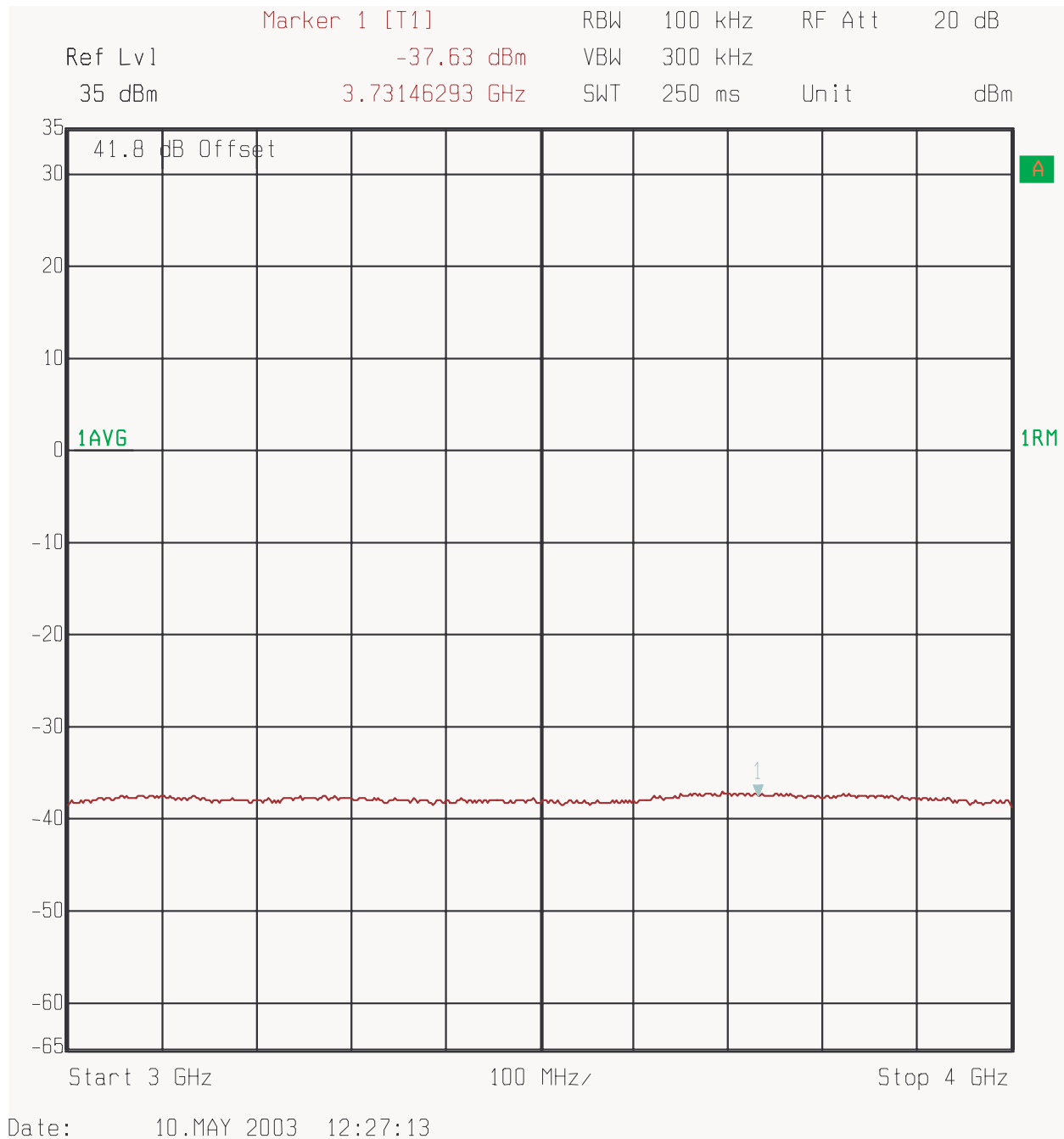

Figure 13 : Conducted Spurious Emissions - 1 Carrier, Channel 17 (4 GHz - 5 GHz)

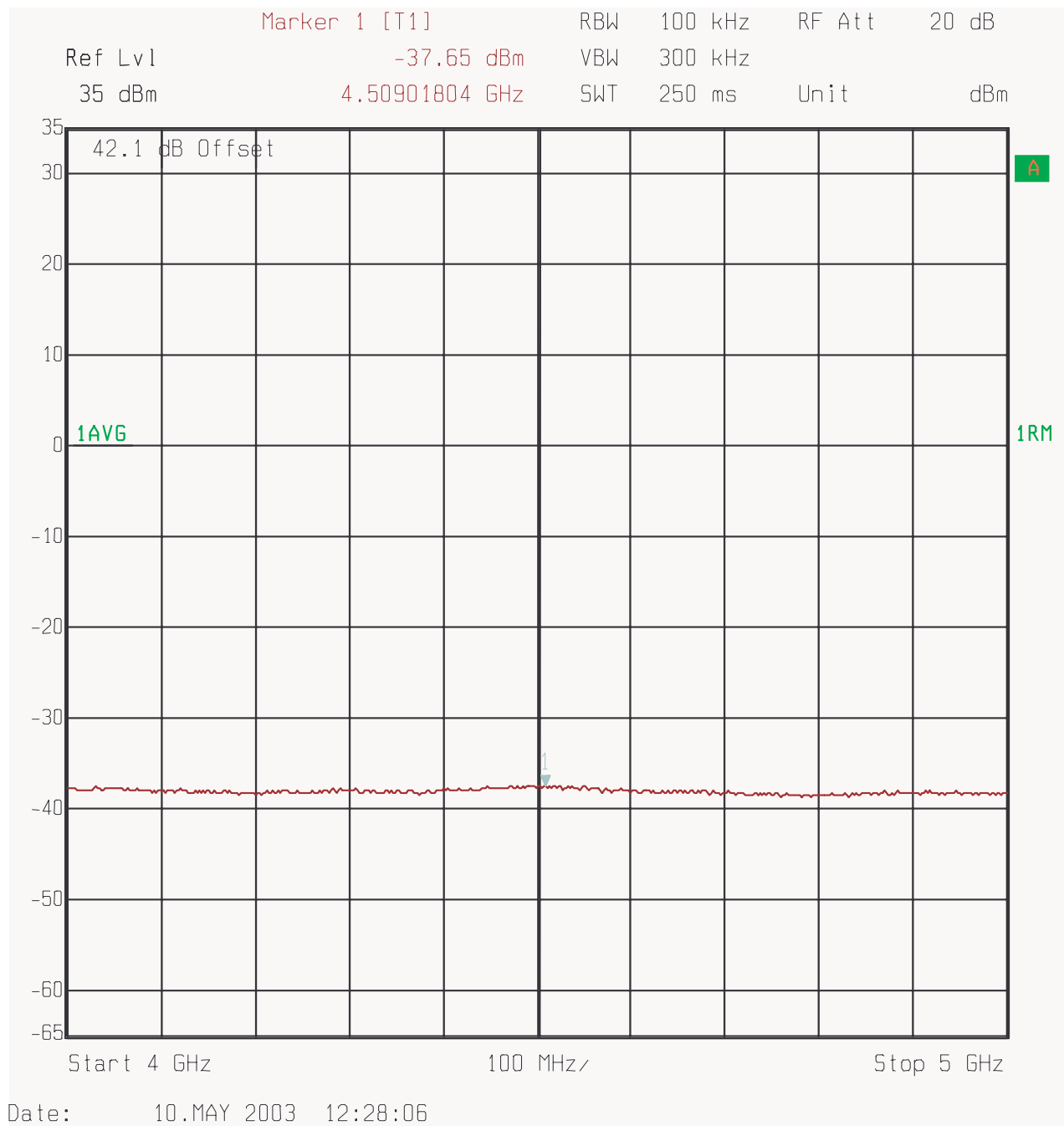

Figure 14 : Conducted Spurious Emissions - 1 Carrier, Channel 17 (5 GHz - 6 GHz)

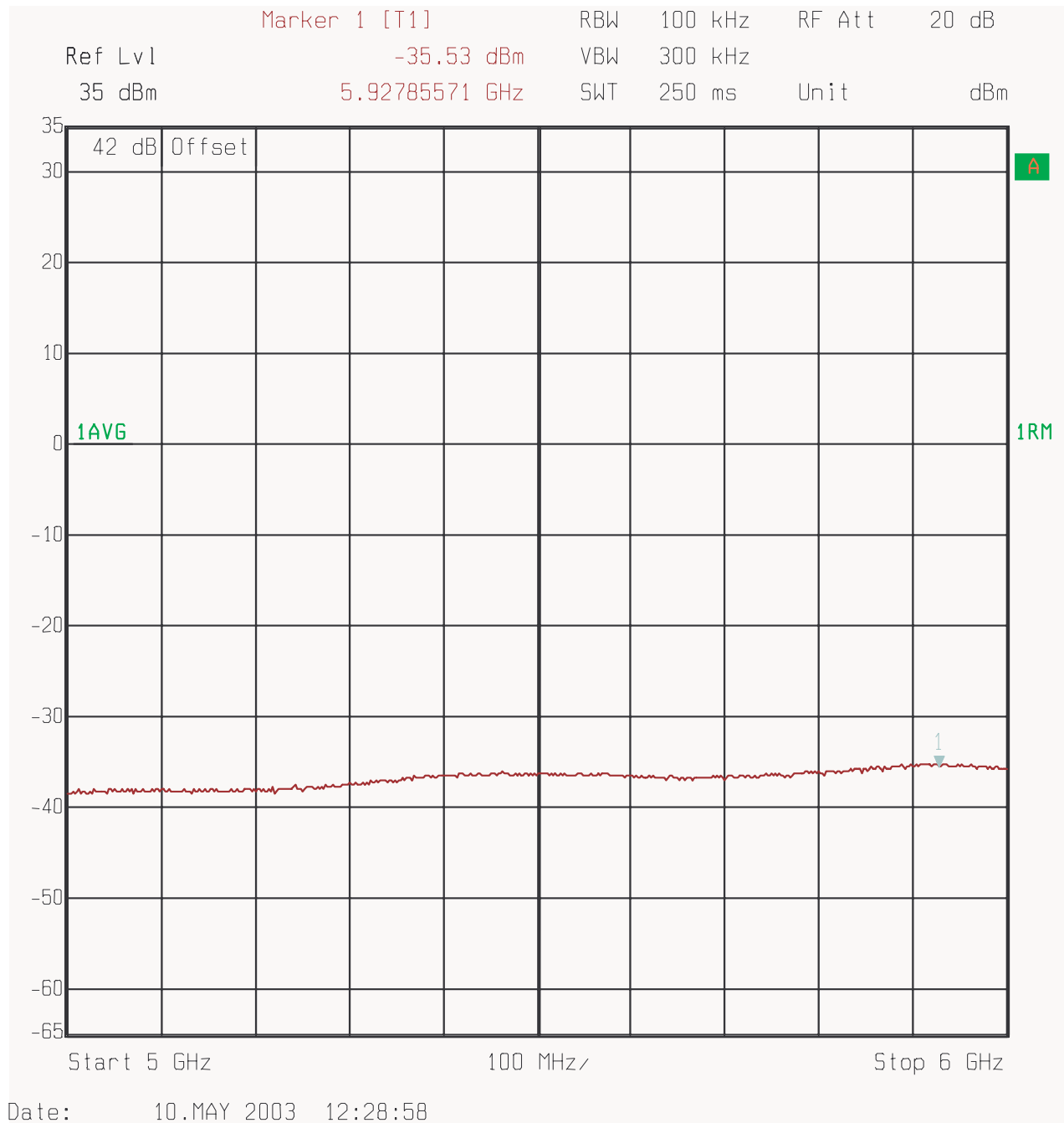

Figure 15 : Conducted Spurious Emissions - 1 Carrier, Channel 17 (6 GHz - 7 GHz)

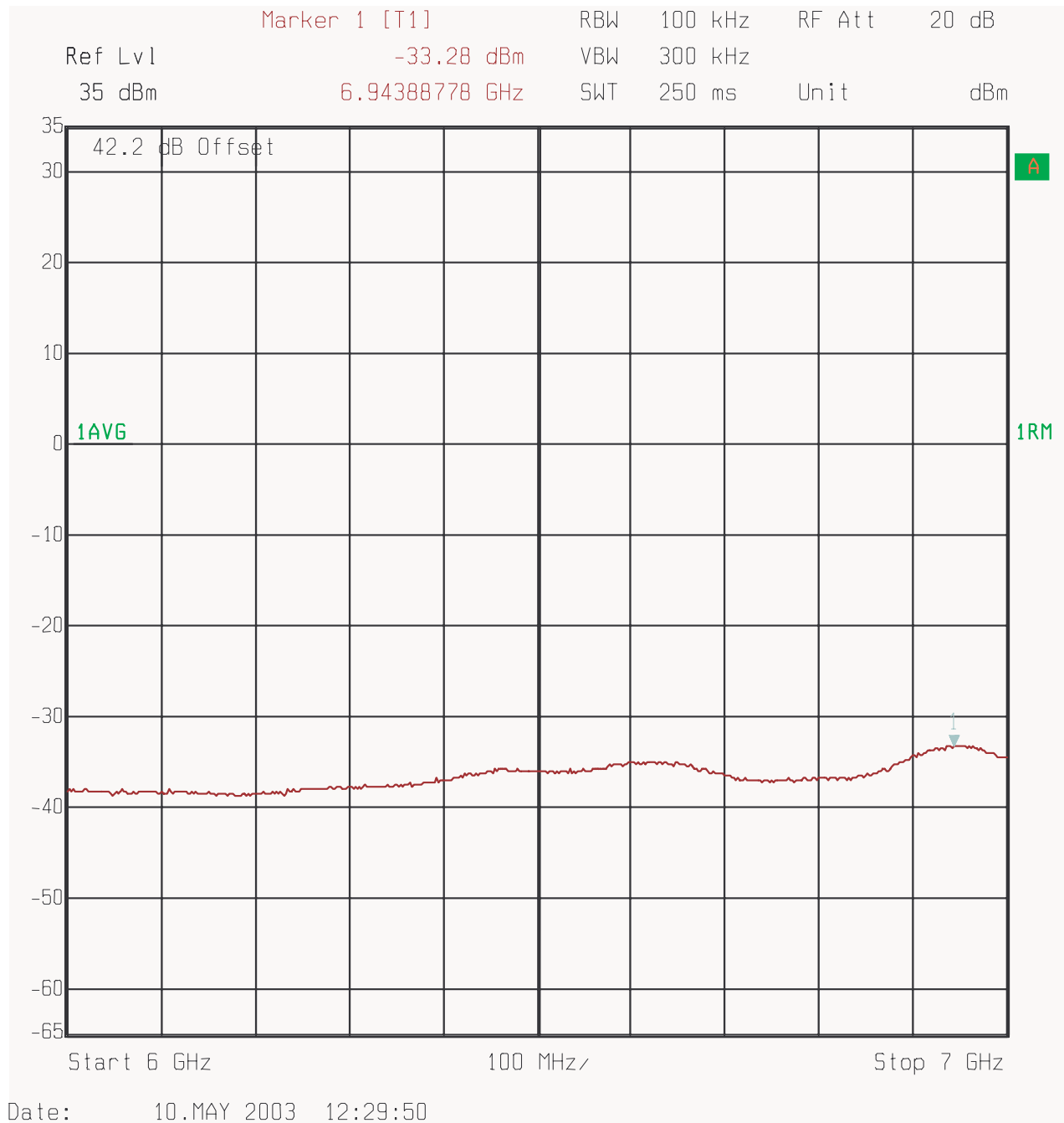

Figure 16 : Conducted Spurious Emissions - 1 Carrier, Channel 17 (7 GHz - 8 GHz)

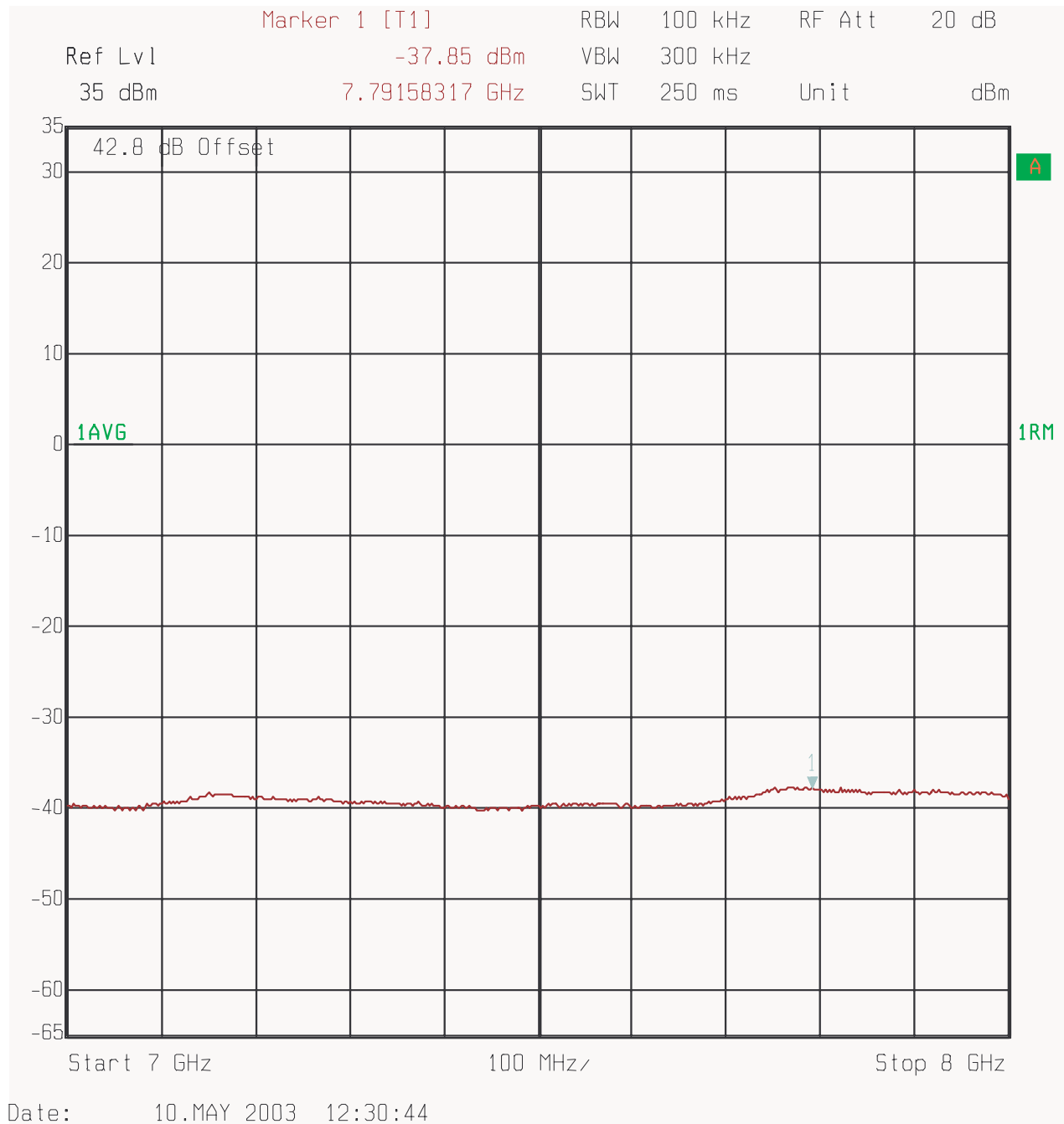

Figure 17 : Conducted Spurious Emissions - 1 Carrier, Channel 17 (8 GHz - 9GHz)

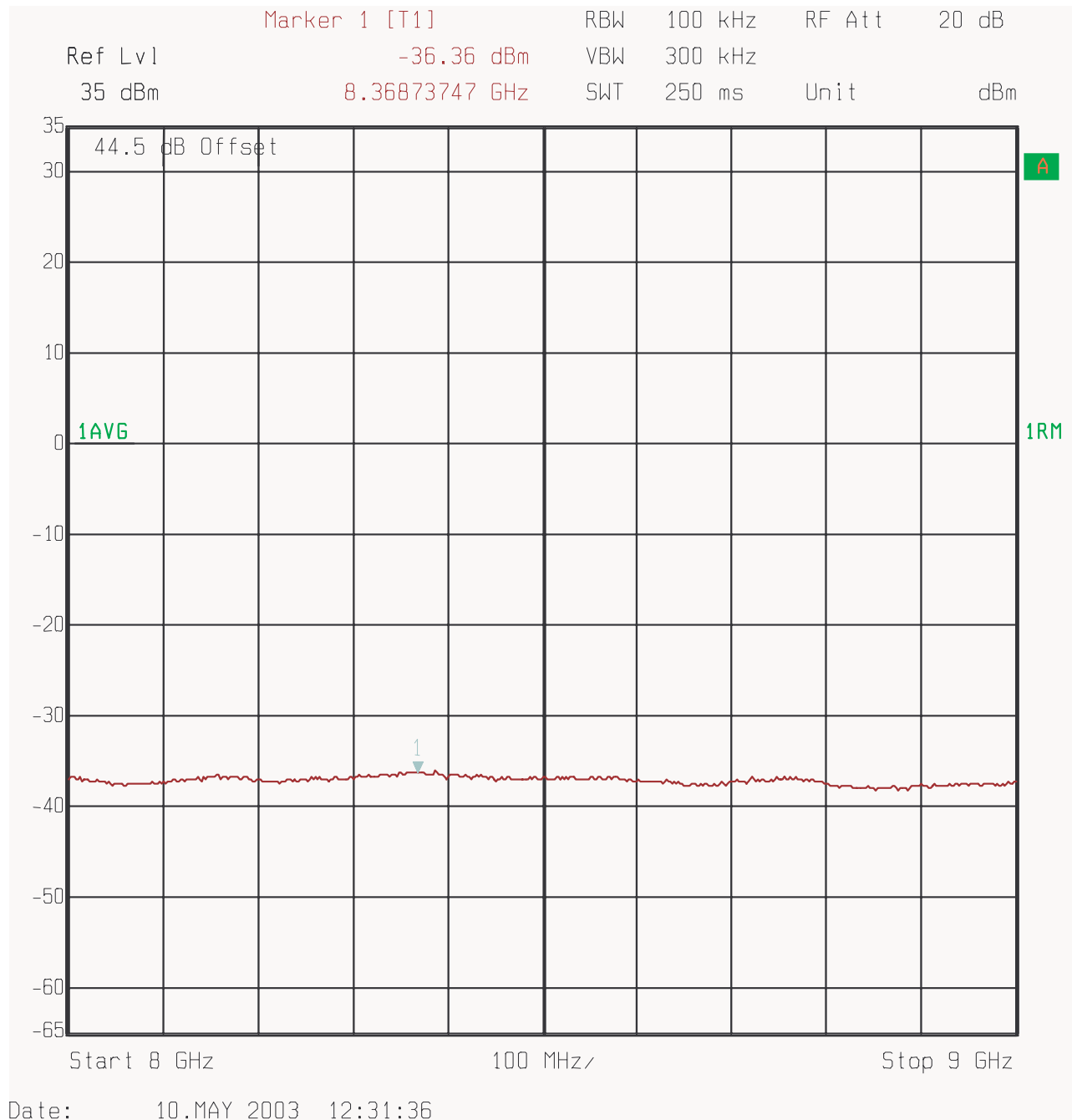

Figure 18 : Conducted Spurious Emissions - 3 Carrier, Channels 17, 58, 99 (Lower adjacent 1 MHz)

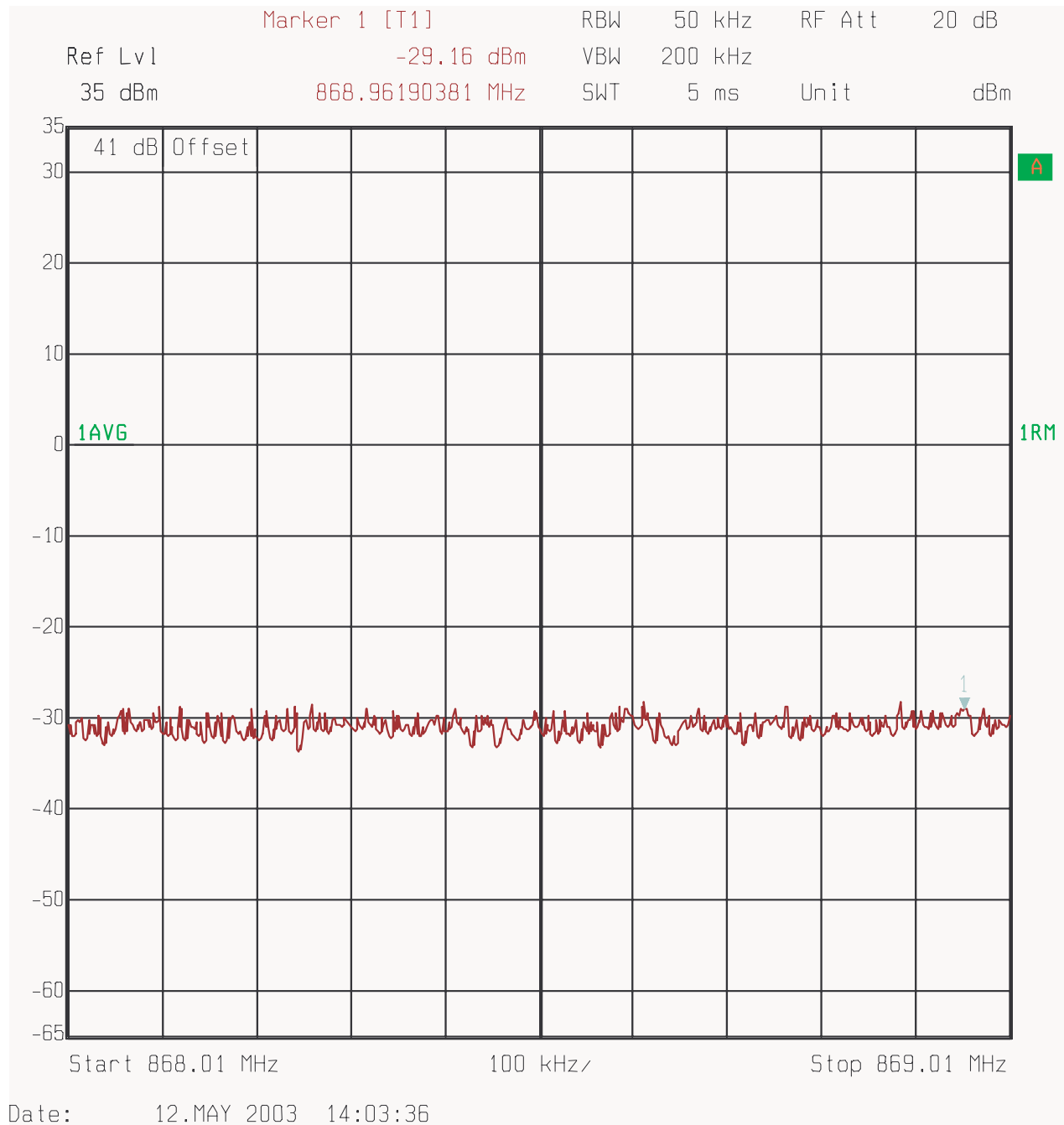

Figure 19 : Conducted Spurious Emissions - 3 Carrier, Channels 201, 242, 283 (Upper adjacent 1 MHz)

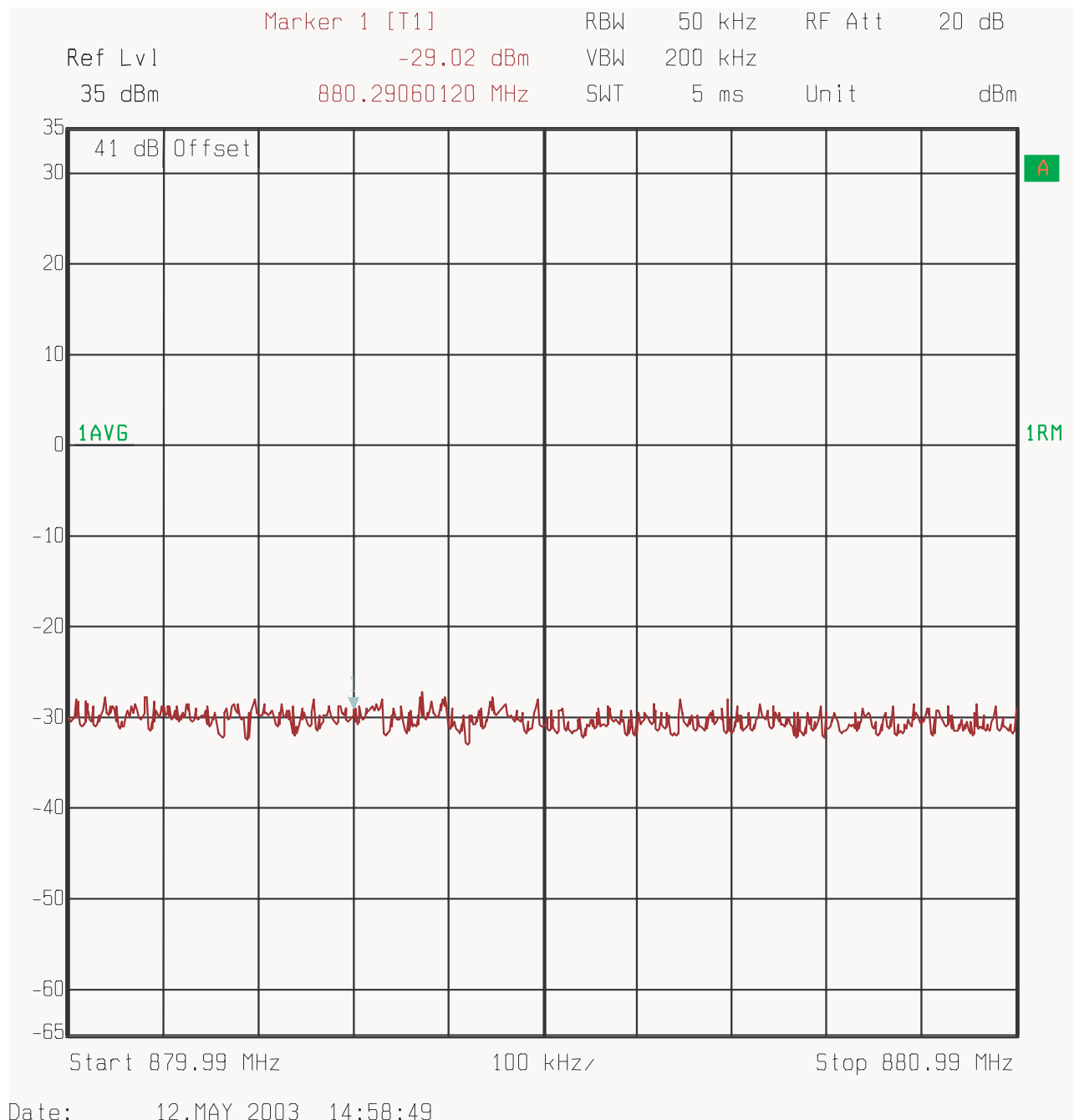

Figure 20 : Conducted Spurious Emissions - 3 Carrier, Chans 17, 58, 99 (400MHz-1 GHz)

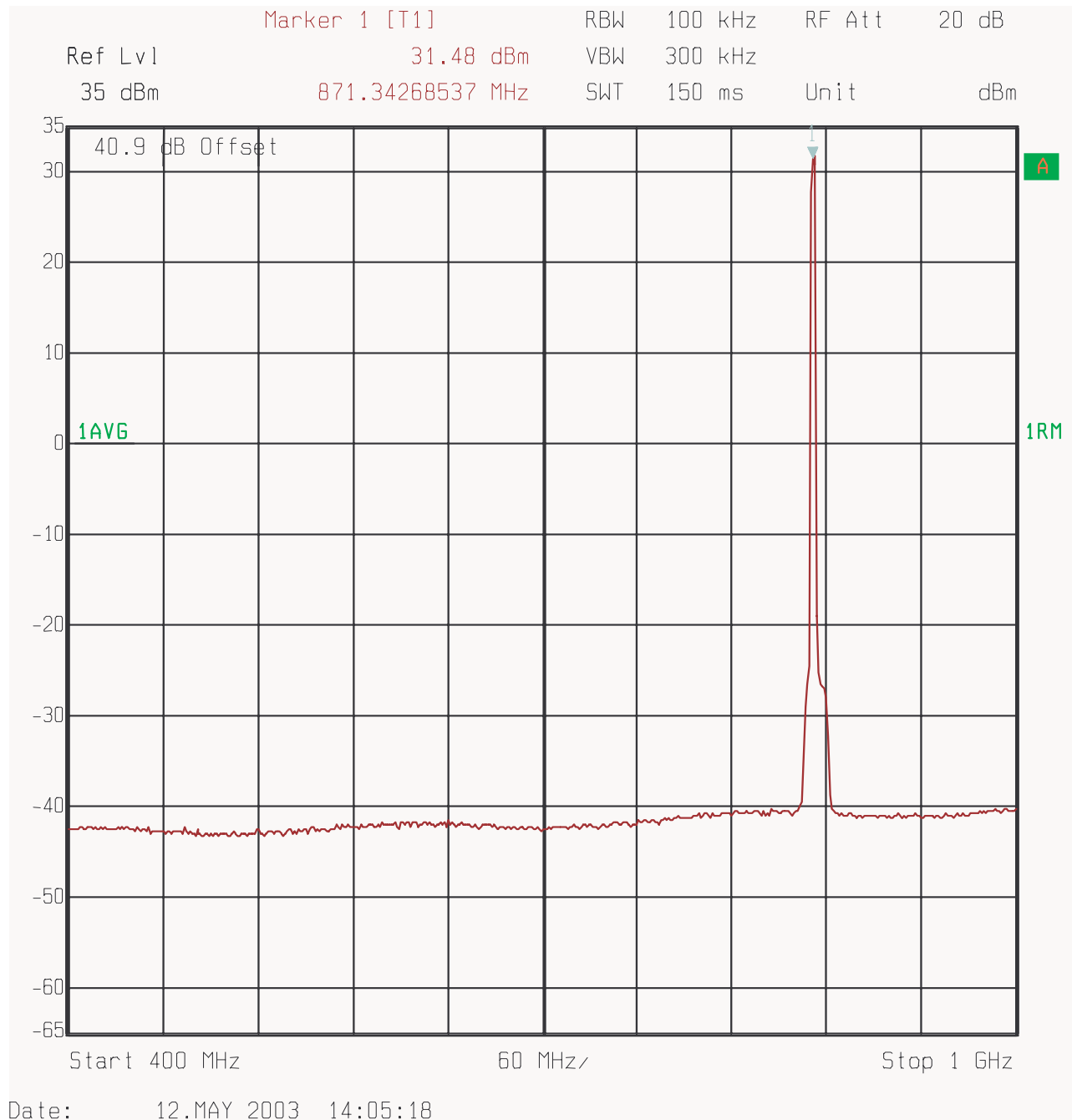

Figure 21 : Conducted Spurious Emissions - 3 Carrier, Channels 17, 58, 99 (1 - 2GHz)

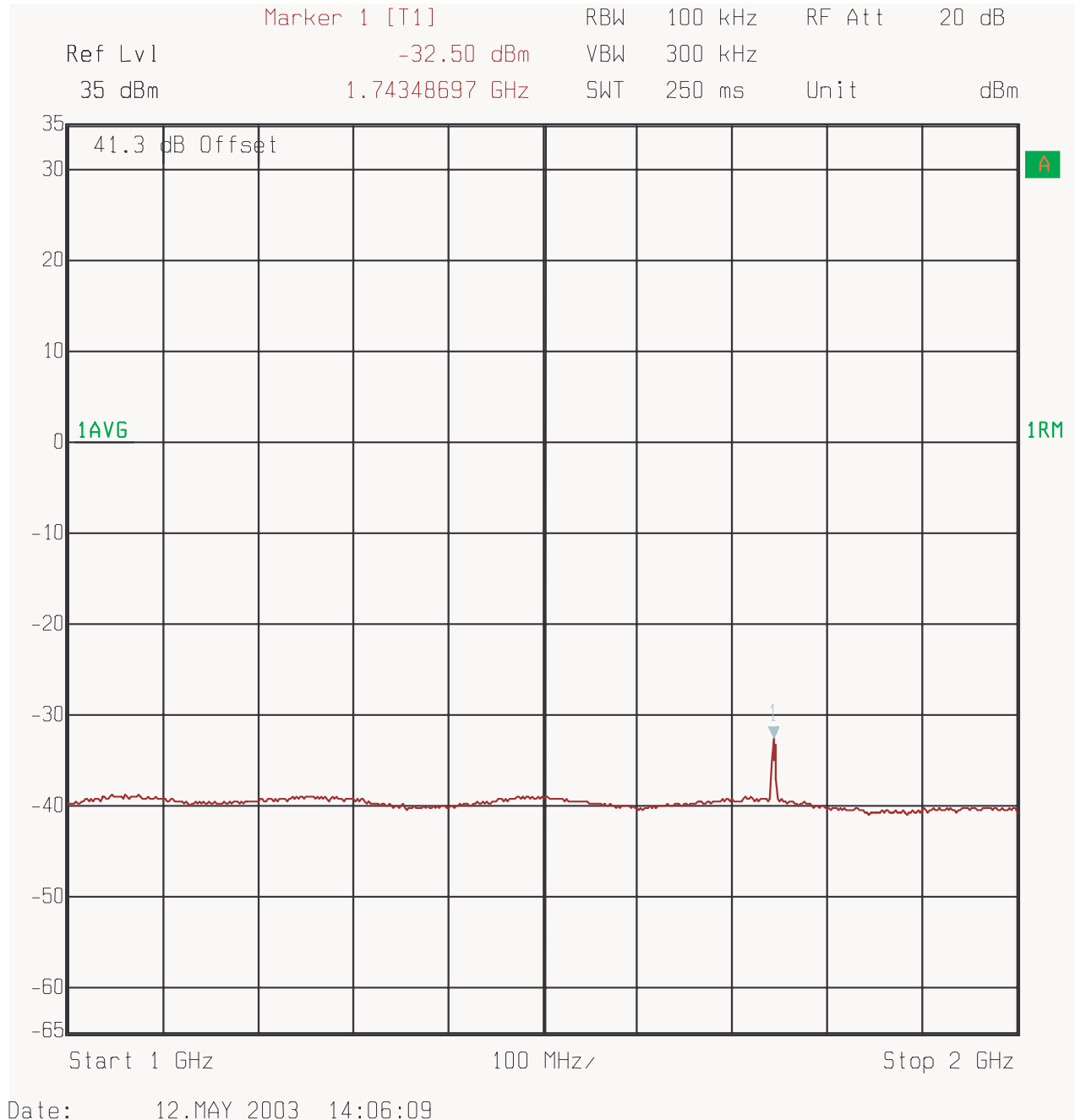

Figure 22 : Conducted Spurious Emissions - 3 Carrier, Channels 17, 58, 99 (2 - 3 GHz)

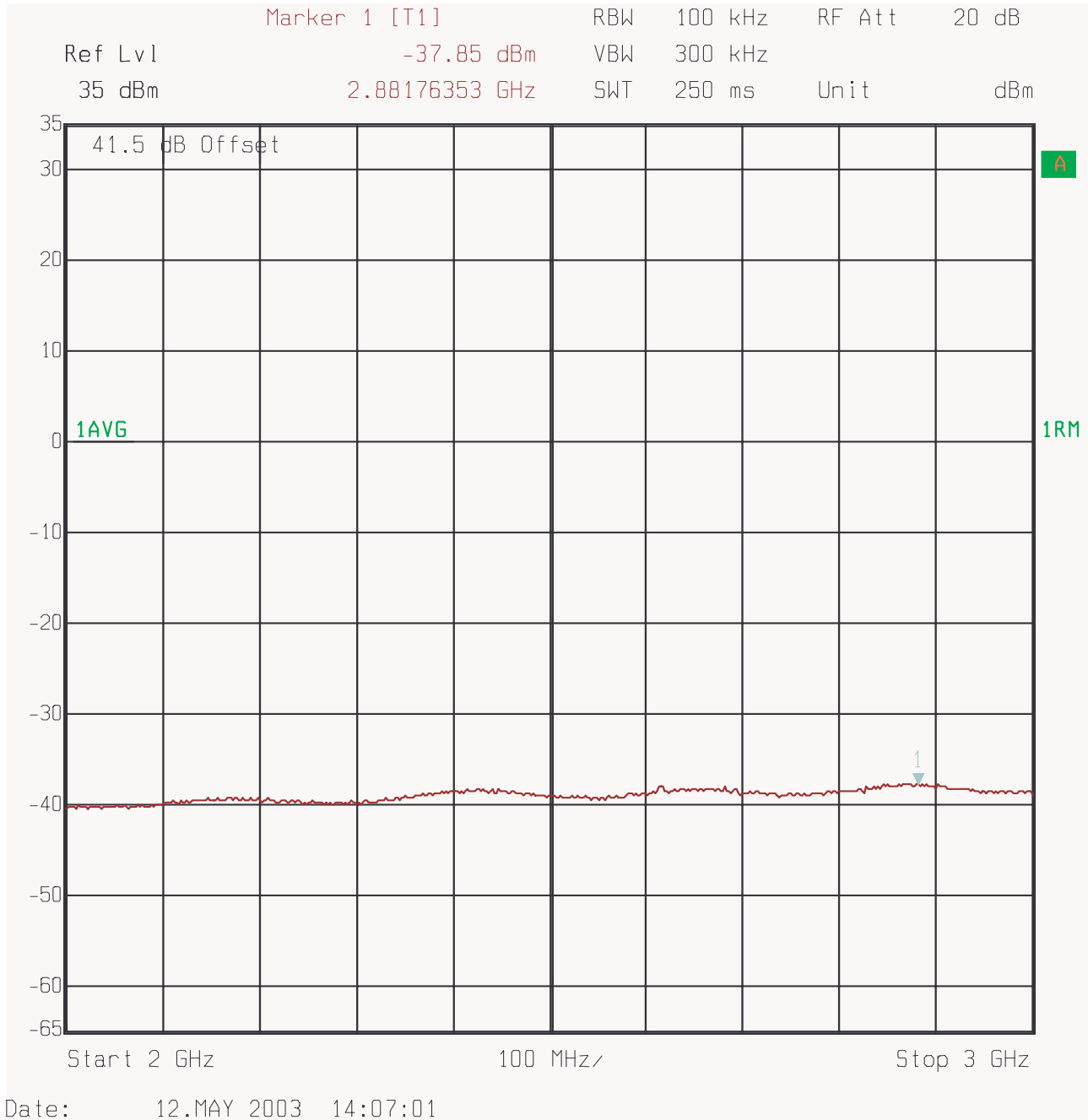

Figure 23 : Conducted Spurious Emissions - 3 Carrier, Channels 17, 58, 99 (3 - 4 GHz)

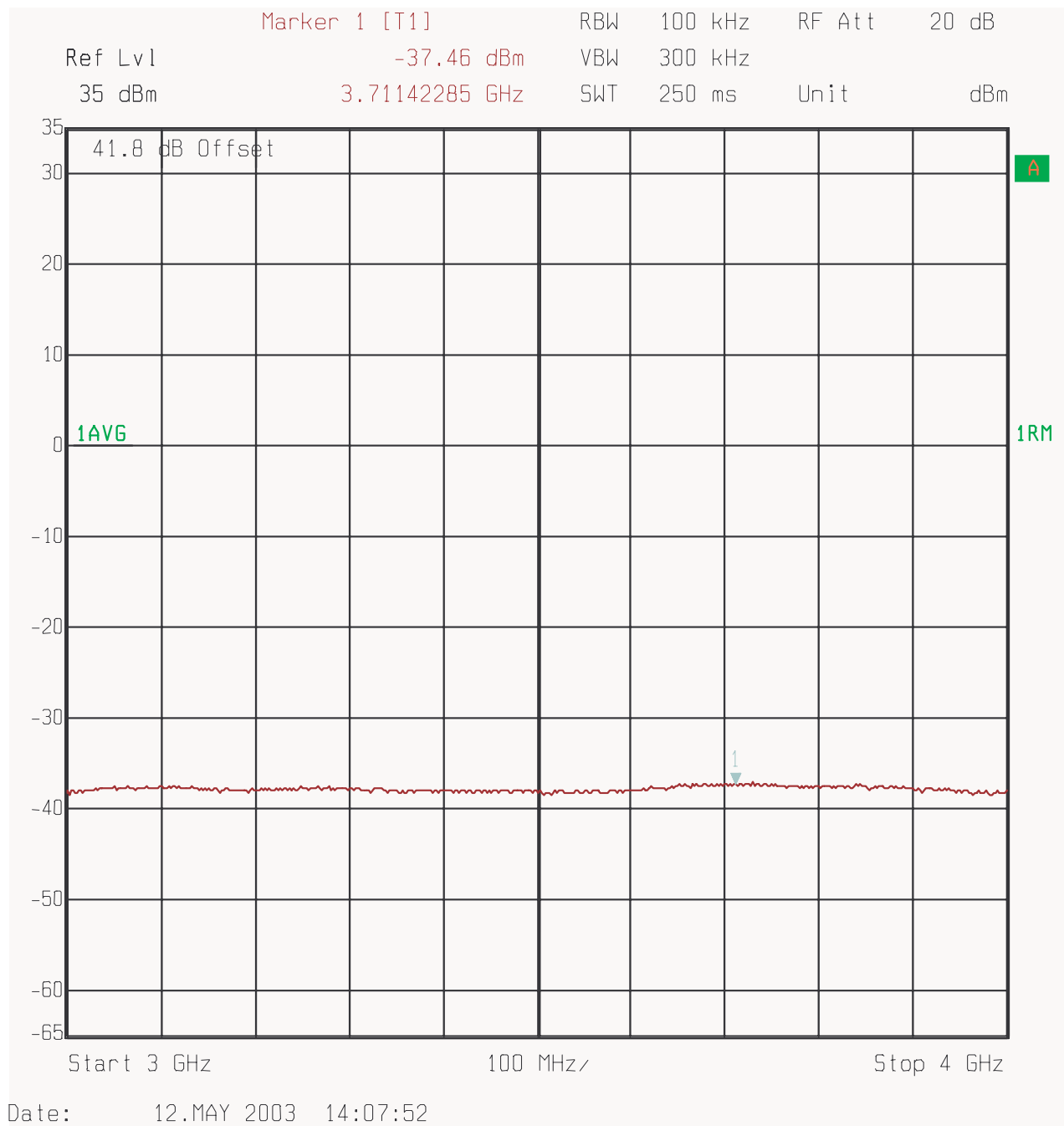

Figure 24 : Conducted Spurious Emissions - 3 Carrier, Channels 17, 58, 99 (4 - 5GHz)

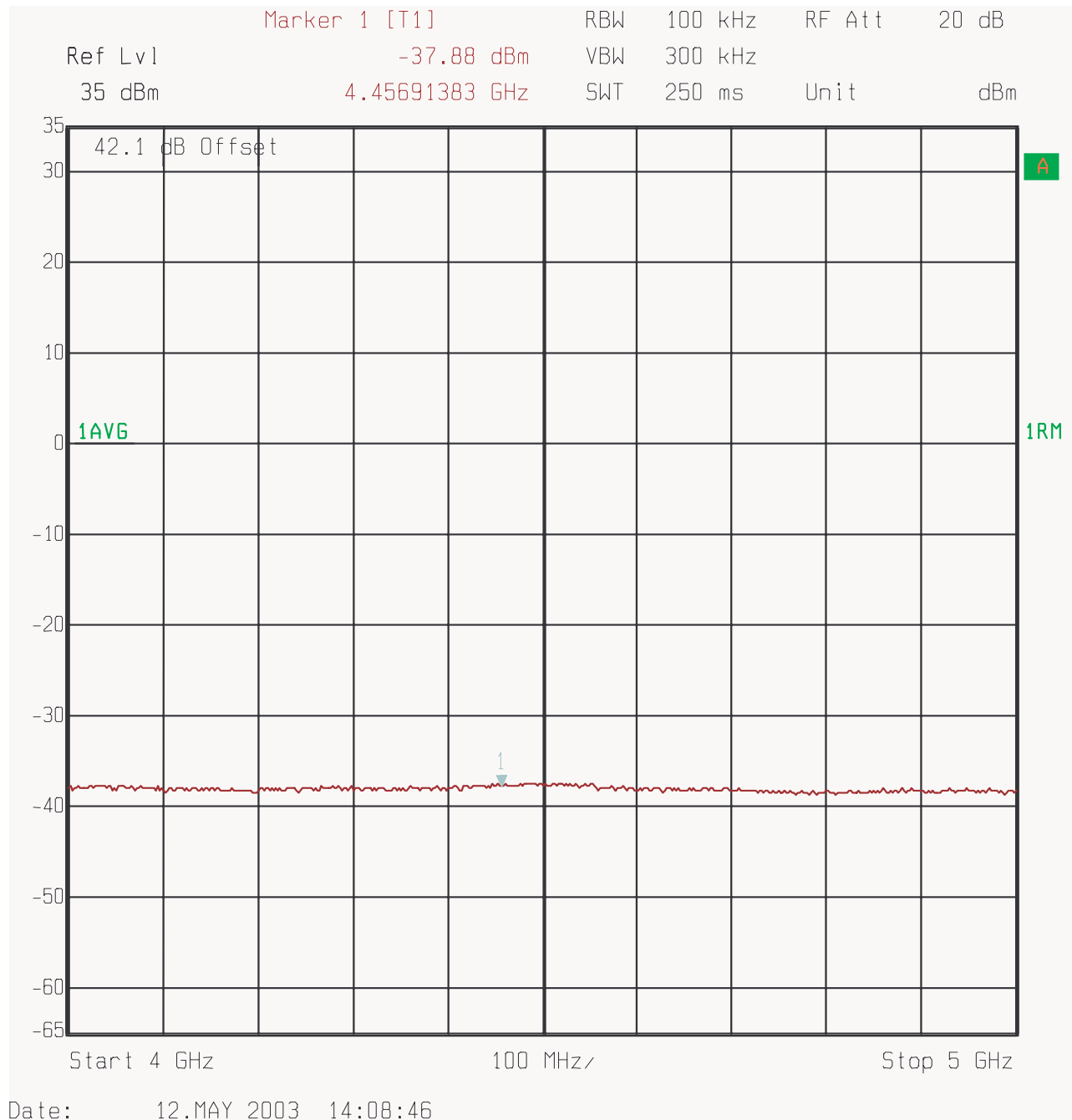

Figure 25 : Conducted Spurious Emissions - 3 Carrier, Channels 17, 58, 99 (5 - 6GHz)

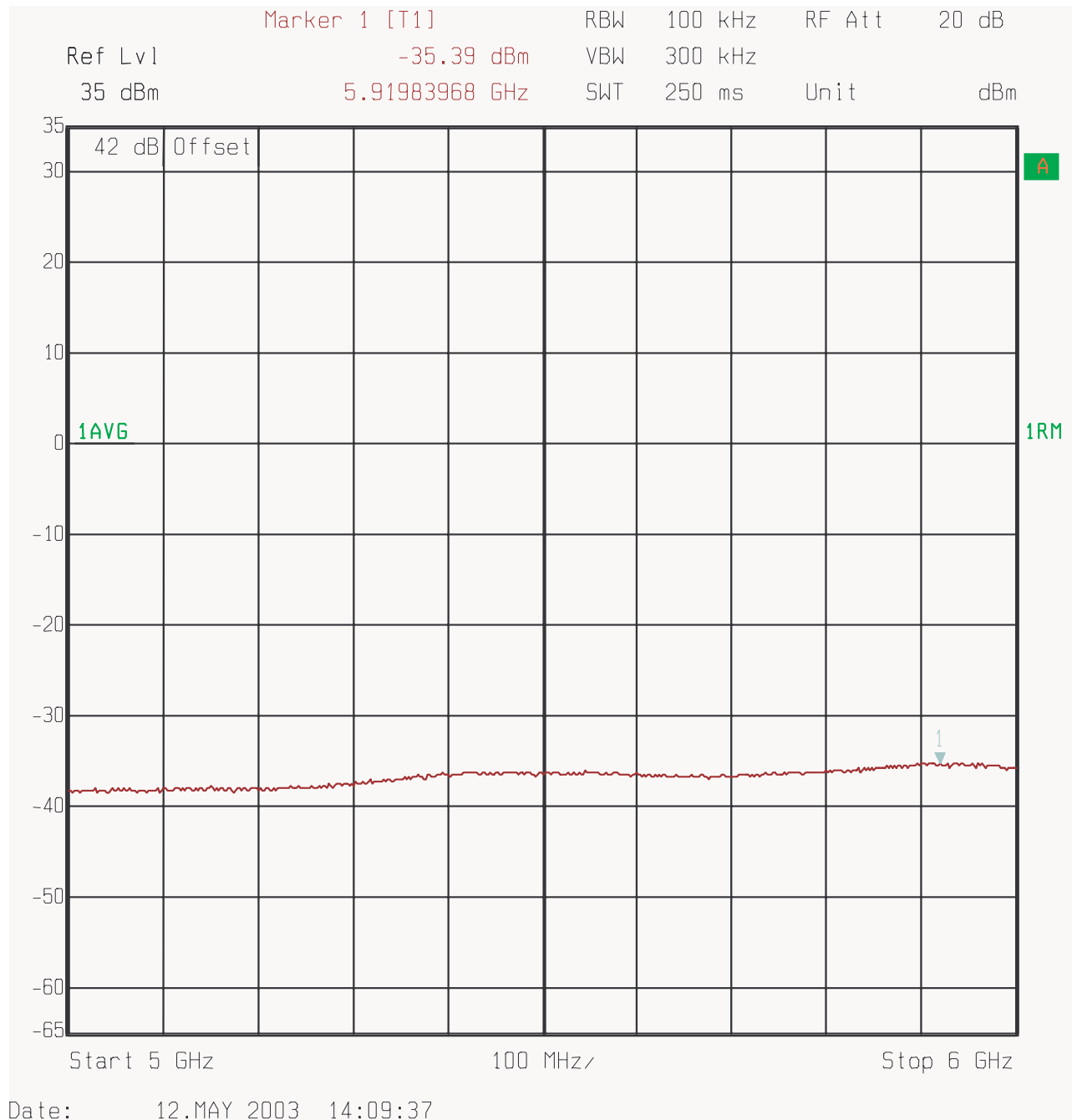

Figure 26 : Conducted Spurious Emissions - 3 Carrier, Channels 17, 58, 99 (6 - 7GHz)

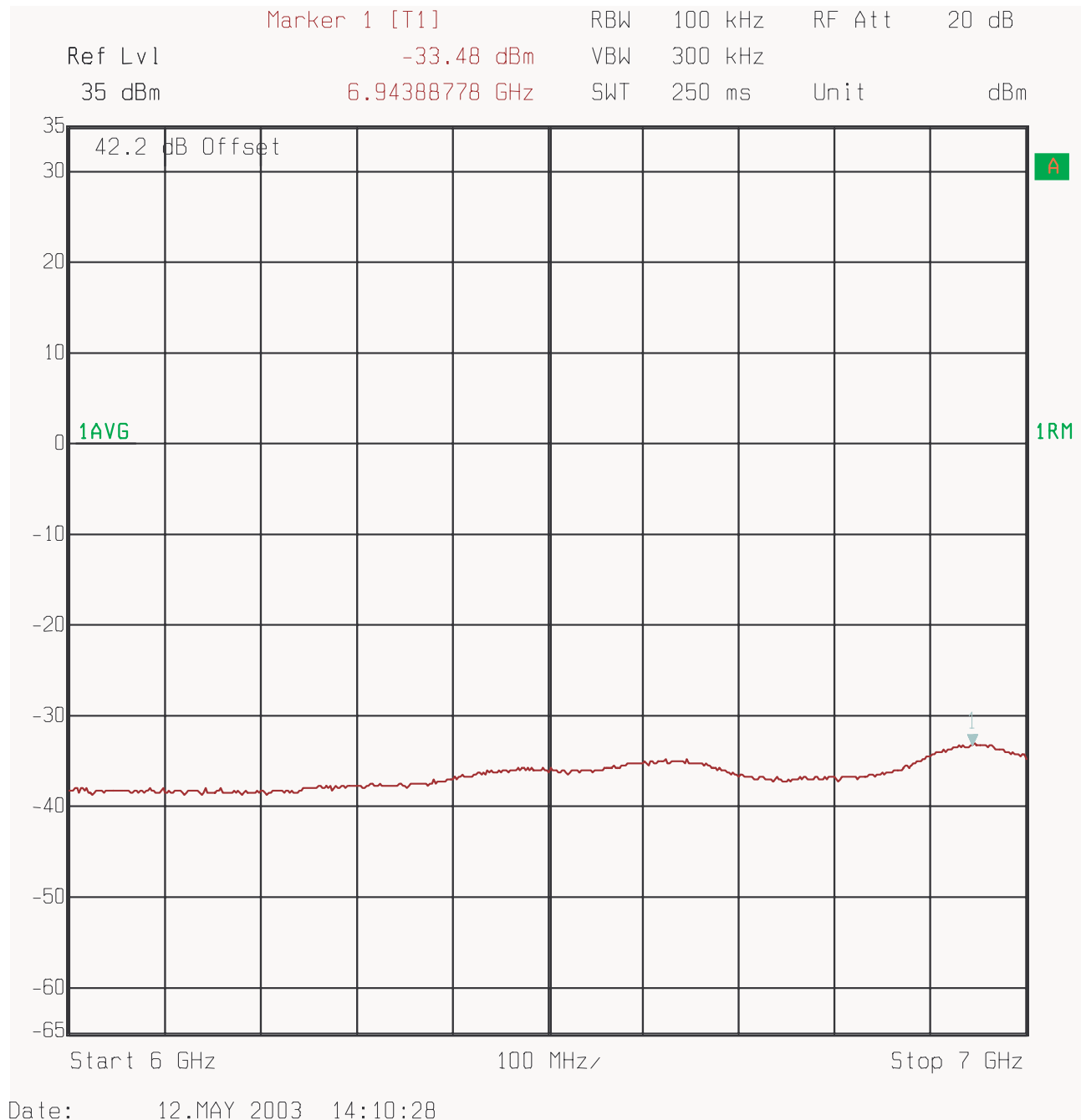

Figure 27 : Conducted Spurious Emissions - 3 Carrier, Channels 17, 58, 99 (7 - 8GHz)

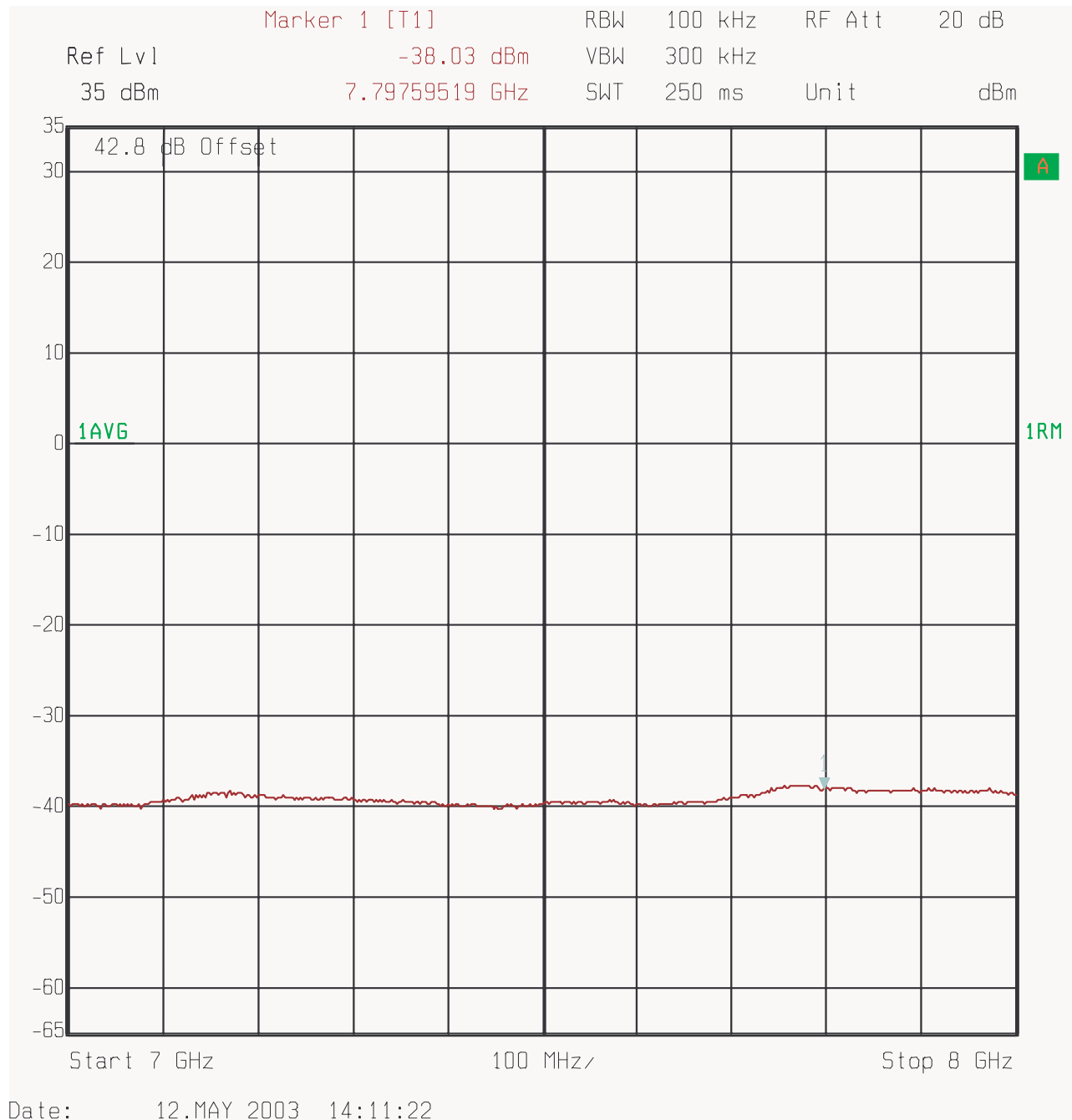
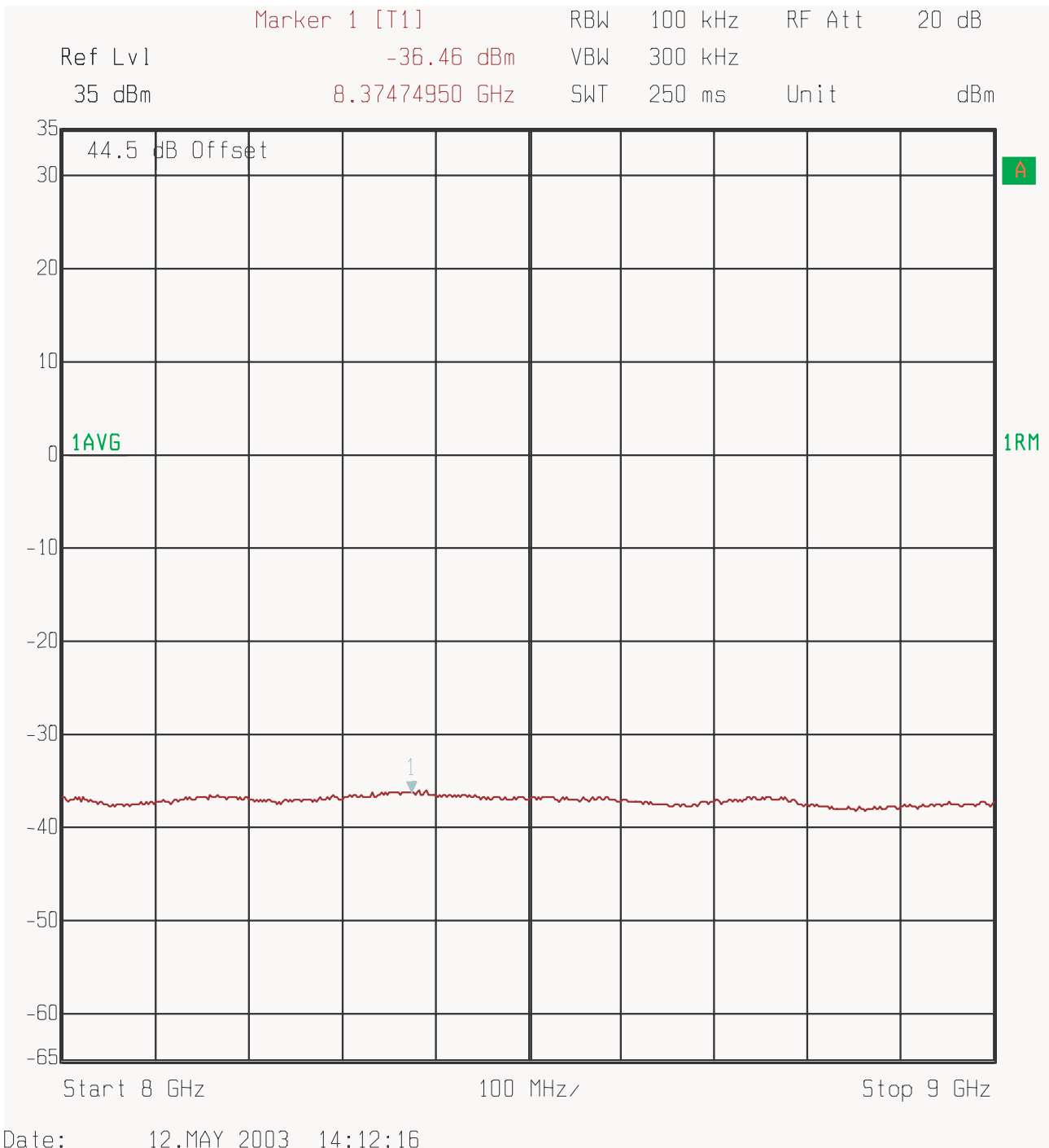

Figure 28 : Conducted Spurious Emissions - 3 Carrier, Channels 17, 58, 99 (8 - 9GHz)



4.4 Frequency Stability

4.4.1 Frequency Stability Requirements

FCC Part 2.1055

(a) The frequency stability shall be measured with variation of ambient temperature as follows:

(1) From -30 to +50 centigrade for all equipment except that specified in subparagraphs (2) and (3) of this paragraph.

(b) Frequency measurements shall be made at the extremes of the specified temperature range and at intervals of not more than 10 centigrade through the range. A period of time sufficient to stabilize all of the components of the oscillator circuit at each temperature level shall be allowed prior to frequency measurement. The short term transient effects on the frequency of the transmitter due to keying (except for broadcast transmitters) and any heating element cycling normally occurring at each ambient temperature level also shall be shown. Only the portion or portions of the transmitter containing the frequency determining and stabilizing circuitry need be subjected to the temperature variation test.

(d) The frequency stability shall be measured with variation of primary supply voltage as follows:

(1) Vary primary supply voltage from 85 to 115 percent of the nominal value for other than hand carried battery equipment.

(2) For hand carried, battery powered equipment, reduce primary supply voltage to the battery operating end point which shall be specified by the manufacturer.

(3) The supply voltage shall be measured at the input to the cable normally provided with the equipment, or at the power supply terminals if cables are not normally provided. Effects on frequency of transmitter keying (except for broadcast transmitters) and any heating element cycling at the nominal supply voltage and at each extreme also shall be shown.

(e) When deemed necessary, the Commission may require tests of frequency stability under conditions in addition to those specifically set out in paragraphs (a), (b), (c) and (d) of this section. (For example, measurements showing the effect of proximity to large metal objects, or of various types of antennas, may be required for portable equipment.)

FCC Part 22.355 Limit

The carrier frequency of each transmitter in the 821-896 MHz Frequency range, must be maintained within 1.5ppm tolerance, according to table C-1 of this section.

4.4.2 Results

The DE incorporates a GPS module from Trimble Navigation. This 10MHz GPS reference is used to synchronize the entire Base Station. The GPS module has a frequency stability of 0.8 ppb over the range of -5C to 70C. The Base Station complies with the requirement as the GPS module is maintained at temperature higher than -5 degree C.

References

- [1] FCC Part 22 Subpart H, “Cellular Radiotelephone Service”, http://www.access.gpo.gov/nara/cfr/waisidx_00/47cfr22_00.html
- [2] FCC Part 2 Subpart J, “Frequency allocations and radio treaty matters; general rules and regulations”, http://www.access.gpo.gov/nara/cfr/waisidx_00/47cfr2_00.html
- [3] FCC Part 24 Subpart E, “Personal Communications Services”, http://www.access.gpo.gov/nara/cfr/waisidx_00/47cfr24_00.html
- [4] TIA/EIA-97-D “Recommended Minimum Performance Standards for Base Stations Supporting Dual Mode Spread Spectrum Systems”, June 2001

END OF DOCUMENT