

List of Exhibits

Exhibit 1 Label Identification

Exhibit 2 Test Report

Exhibit 3 Technical Description

Exhibit 4 Circuit Schematics

Exhibit 5 User Documentation

Exhibit 6 Photographs

EXHIBIT 2

Test Report

Applicant: Northern Telecom Ltd.

For Type Acceptance/Certification on:

AB6NT800FRM

1 Introduction

This information is submitted in accordance with the FCC rules and regulations, Part 2, Subpart J, §2.1033 through §2.1057 and Industry Canada RSS 129 radio standard for Type Acceptance/Certification of the Northern Telecom's (Nortel Networks) CDMA 800 MHz Flexible Radio Module (FRM).

This 800 MHz FRM is intended for use in the Domestic Public Cellular Radio Telecommunications Service and is designed in accordance with the following standards:

- *CFR 47, Part 22, Subpart H, Domestic Public Cellular Radio Telecommunications Service*
- *TIA/EIA/IS-95-A, Mobile Station - Base Station Compatibility Standard for Dual-Mode Wideband Spread Spectrum Cellular System, May 1995*

1.1 Test Result Summary

Table 1 summarizes the measurement results for the CDMA 800 MHz FRM.

Table 1: Test Results Summary

FCC Measurement Specification	FCC Limit Specification	Description	Result
2.1046	22.913	RF Output Power	Compliant
2.1047	22.901	Modulation Characteristics	Not Applicable
2.1049	22.917	Occupied Bandwidth	OBW = 1.2625 MHz
2.1051, 2.1057	22.917	Spurious Emissions at Antenna Terminals	Compliant
2.1053, 2.1057	22.917	Field Strength of Spurious Emissions	Compliant
2.1055		Frequency Stability	Compliant

2 Engineering Declaration

The CDMA 800 MHz Flexible Radio Module has been tested in accordance with the requirements contained in the Federal Communications Commission Rules and Regulations Parts 2 and 22 and Industry Canada Radio Standard Specification 129, issue 1. To the best of my knowledge, these tests were performed in accordance with good engineering practices using measurement procedures consistent with industry or commission standards and demonstrate that this equipment complies with the appropriate standards. All tests were conducted on a representative sample of the equipment for which type acceptance/certification is sought.

Signed Official copy kept on file by Nortel Networks

November 30, 1998

Rupinder Randhawa
Technical Manager
Wireless Systems Integrity
Nortel Networks
Calgary, Alberta

Date

3 Type Acceptance Application Requirements

3.1 Name of Applicant

The applicant is Northern Telecom (Nortel Networks) Limited.

3.2 Identification of Equipment

The equipment in this application for type acceptance is the Northern Telecom's (Nortel's) CDMA 800 MHz Flexible Radio Module (FRM). The 800MHz FRM will be marketed under the model number NT800FRM. The FCC ID number sought is AB6NT800FRM.

3.3 Quantity Production

The 800 MHz FRM will be produced in quantity.

3.4 Technical Description

See Exhibit 3.

3.5 Types of Emissions

The 800 MHz FRM Assembly is designed to operate in digital mode. The emission type is FXW for CDMA mode. The emission designator is **1M25FXW**.

3.6 Frequency Range

The 800 MHz FRM operates in the 800 MHz cellular band where the operating frequency ranges are 824 – 849 MHz for the Receiver and 869 – 894 MHz for the Transmitter. The following table shows the valid CDMA channels within this band.

Band	CDMA Channel Number	Transmitter Frequency Assignment (MHz)		Valid CDMA Frequency Assignment
		Mobile	Base	
A''	991 – 1012	824.04 – 824.67	869.04 – 869.67	In-Valid
	1013 – 1023	824.70 – 825.00	869.70 – 870.00	Valid
A	1 – 311	825.03 – 834.33	870.03 – 879.33	Valid
	312 – 333	834.36 – 834.99	879.36 – 879.99	In-Valid
B	334 – 355	835.02 – 835.65	880.02 – 880.65	In-Valid
	356 – 644	835.68 – 844.32	880.68 – 889.32	Valid
	645 – 666	844.35 – 844.98	889.35 – 889.98	In-Valid

Band	CDMA Channel Number	Transmitter Frequency Assignment (MHz)		Valid CDMA Frequency Assignment
		Mobile	Base	
A'	667 – 688	845.01 – 845.64	890.01 – 890.64	In-Valid
	689 – 694	845.67 – 845.82	890.67 – 890.82	Valid
	695 – 716	845.85 – 846.48	890.85 – 891.48	In-Valid
B'	717 – 738	846.51 – 847.14	891.51 – 892.14	In-Valid
	739 – 777	847.17 – 848.31	892.17 – 893.31	Valid
	778 – 799	848.34 – 848.97	893.34 – 893.97	In-Valid

3.7 Range of Operating Power

The 800 MHz FRM range of operating RF power is 30.0 dBm (1W) to 44.0dBm (25 W).

3.8 Maximum Power Rating

The maximum RF power output of the CDMA 800 MHz FRM is 25 W (44.0 dBm).

3.9 Function of Each Active Circuit Device

See Exhibit 5 for a listing of devices incorporated in the FRM.

3.10 Complete Circuit Diagrams

Exhibit 4 contains schematics of devices incorporated in the Transmit/Receive module. The rest of the RF chain is made up of OEM equipment that has been submitted separately for FCC approvals.

The SCPA 800MHz power amplifier is approved under FCC ID E675JS0030.

3.11 User Manual

See Exhibit 5.

3.12 Tune-Up Procedure

The tune-up tests will be performed as part of the factory testing on the FRM. This procedure includes power output levels, spurious emissions, and occupied bandwidth. There are no user adjustments that will have any effect on these settings. No tune-up testing is required in the field.

3.13 Circuit Description for Frequency Determining and Stabilizing

The Global Positioning Satellite Timing Module (GPSTM) is the primary clock source in the system. It consists of two outputs:

EVEN_SEC Clock and,
SYS_CLK (at 8fc or 9.8304 MHz)

In addition, the GPSTM has a 10 MHz reference output that can be used to synchronize external measurement equipment during system testing.

The GPSTM distributes the primary clock signals directly to the Control Module (CM) and the CORE modules (see Exhibit 3) which in-turn distribute the clock signals to the digital modules and to the FRM via the high speed optical link.

The GPSTM has a frequency stability of better than 1.0 parts per billion.

3.14 Circuit Description for Suppression of Spurious Radiation

The TX band pass filter in the DPM provides out of band emission rejection and permits only signals in the TX band to the antenna for emission.

3.15 Circuit Description for Limiting Modulation

This systems employs digital modulation techniques producing CDMA forward and reverse channel air interfaces which are compatible with ANSI J-STD-008, Personal Station – Base Station Compatibility Requirements for 1.8 to 2.0 GHz Code Division Multiple Access (CDMA) Personal Communications Systems.

3.16 Circuit Description for Limiting Power

A power detector is located in the FRM. This circuit will accurately measure the RMS power of the composite CDMA waveform. The system will step down the output power if the detected signal exceed the maximum power setting of the system.

3.17 Photographs

See Exhibit 6.

3.18 Standard Test Conditions and Test Equipment

The FRM was tested under the following standard test conditions unless otherwise noted:

Ambient temperature: 20 to 35 degrees C

Ambient humidity: 20 to 40%

DC supply voltage: -48 Vdc (nominal)

3.19 EUT Identification List

The following table shows the identification of the components tested in this report

Equipment Description	Model /Part Number	Release Number	Serial Number
-----------------------	--------------------	----------------	---------------

Equipment Description	Model /Part Number	Release Number	Serial Number
800 MHz Flexible Radio Module (comprised of main modules below):	NT800FRM	0D	NA
a) DPM	NTGS89BB	P5	
b) TRM	NTGS81AA	N6	NNTM532VJ4J6
c) EOM	NTGS54BA	P1	NNTM53608EM3
d) Processor Board	NTGS82AA	N2	NNTM532XBRMR
e) PA	NTGS86AA	N4	NNTM74P00030

3.20 Test Equipment List

Description	Manufacturer	Model	Serial Number	Cal. Due Date
9 kHz to 40 GHz, Spectrum Analyzer	Rohde & Schwarz	FSEK	DE22471	Nov. 28/98
9 kHz to 2.9 GHz, RF Filter/Preselector	HP	85420E	3705A00184	April 1/99
9 kHz to 2.9 GHz, EMI Receiver	HP	8542E	3710A00202	April 1/99
RF Power Meter	HP	438A	3008A07337	Jan. 9/98
30 dB Attenuator	Narda	769-30	03265	Verified before use
Splitter	Weinschel	1506A	LG891	Verified before use
Biconolog Antenna 20 MHz to 2 GHz	EMCO	3141	9707-1067	July 13/99
Log Periodic Antenna 1 GHz to 26.5 GHz	Rohde & Schwarz	HL025	355618/010	Oct. 06/99
1 – 18 GHz Low Noise Amplifier	Miteq	N/A	513159	Lab Calibrated

4 Transmitter Test and Measurement Results

4.1 RF Power Output

4.1.1 RF Power Output Requirements

FCC Part 2.1046 / IC RSS129 Sec. 9.2.3

(a) For transmitters other than single sideband, independent sideband and controlled carrier radiotelephone, power output shall be measured at the RF output terminals when the transmitter is adjusted in accordance with the tune-up procedure to give the values of current and voltage on the circuit elements specified in 2.983(d)(5). The electrical characteristics of the radio frequency load attached to the output terminals when this test is made shall be stated.

FCC Limit (Part 22.913)

The maximum effective radiated power (ERP) of base transmitters and cellular transmitters must not exceed 500 Watts.

IC Limit (RSS129 Sec. 9.2.3)

The output power shall be capable of being adjusted to within +/-1.0 dB of the manufacturer's rated power.

4.1.2 Test Method

The DE was setup via the BTS controller to enable the FRM to transmit at maximum power. Measurements were made on channels at the bottom, middle and top of the licensed bands. The RF output power was measured using the power meter.

4.1.3 Test Setup

The set-up used for the FRM RF output power test is illustrated in Figure 1.

Figure 1: Test Setup for RF Power Output Measurement

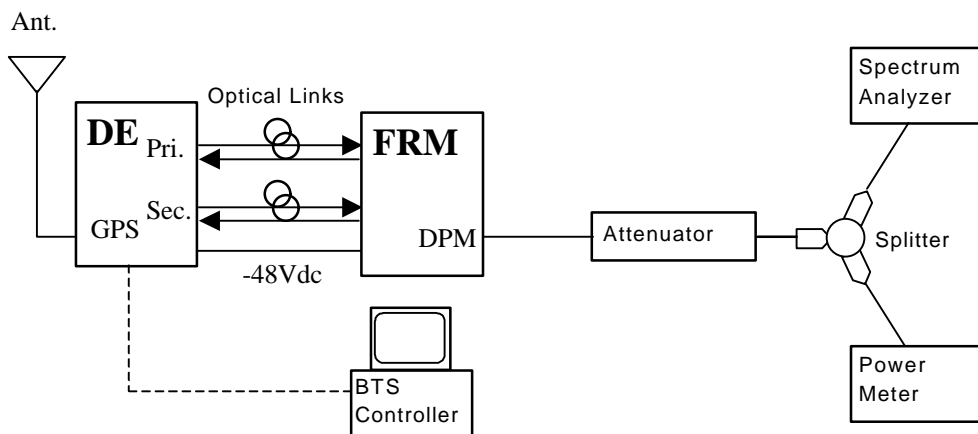

4.1.4 Test Result

The 800 MHz FRM complies with the requirement. The maximum measured RF output power from the FRM was +44.0 dBm. The RF power output measured on different channels is shown in Table 2.

Table 2: RF Output Power of 800 MHz FRM

Channel Number (Band)	Frequency (MHz)	Measured RF Output Power (dBm)	Maximum Rated Power (dBm)	FCC Limit (dBm)
8 (A)	870.24	43.6	43.5	50
283 (A)	878.49	43.6	43.5	50
293 (A)	878.79	44.0	43.5	50
374 (B)	881.22	44.0	43.5	50
384 (B)	881.52	44.0	43.5	50
616 (B)	888.78	44.0	43.5	50
758 (B')	892.74	43.6	43.5	50

4.2 Occupied Bandwidth (Digital)

4.2.1 Occupied Bandwidth Requirements

FCC Part 2.1049

The OBW, that is the frequency bandwidth such that, below its lower and above its upper frequency limits, the mean powers radiated are each equal to 0.5 percent of the total mean power radiated by a given emission shall be measured under the following conditions as applicable:

(g) Transmitter in which the modulating baseband comprises not more than three independent channels - when modulated by the full complement of signals for which the transmitter is rated. The level of modulation for each channel should be set to that prescribed in rule parts applicable to the services for which the transmitter is intended. If specific modulation levels are not set forth in the rules, the tests should provide the manufacturer's maximum rated condition.

(h) Transmitters employing digital modulation techniques - when modulated by an input signal such that its amplitude and symbol rate represent the maximum rated conditions under which the equipment will be operated. The signal shall be applied through any filter networks, pseudo-random generators or other devices required in normal service. Additionally, the occupied bandwidth shall be shown for operation with any devices used for modifying the spectrum when such devices are optional at discretion of the user.

4.2.2 Test Method

The DE was setup via the BTS controller to enable the FRM to transmit at maximum power. Measurements were made on channels at the bottom, middle and top of the licensed bands. The occupied bandwidth was measured using the 99% channel power feature of the spectrum analyzer.

4.2.3 Test Setup

The set-up used for the FRM Occupied bandwidth test is illustrated in Figure 2.

Figure 2: Test Setup for RF Power Output Measurement

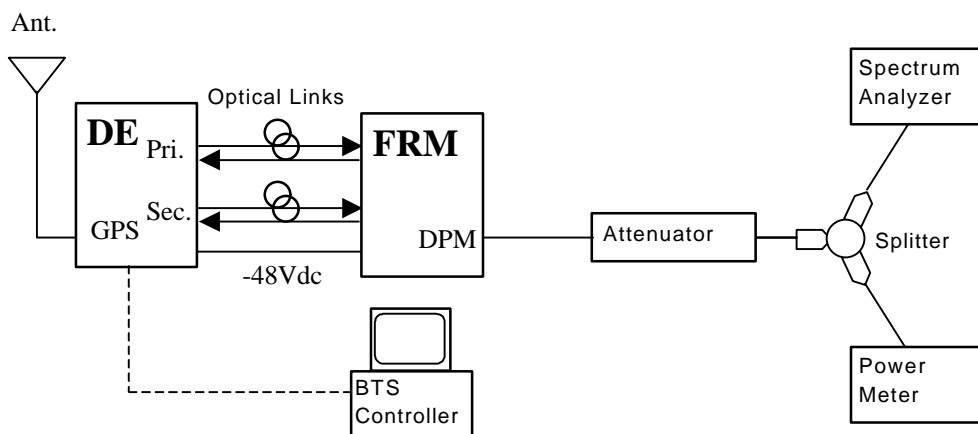

4.2.4 Test Results

The measured output power from the Base Station was +44.0 dBm. The Base Station complies with the requirement. Table 1 shows the measured occupied bandwidth at the different channels. Figure 3 shows a plot of the maximum measured occupied bandwidth of 1262.5 kHz.

Table 3: Occupied Bandwidth of 800 FRM

Channel Number (Band)	Frequency (MHz)	Measured Occupied Bandwidth (kHz)
8 (A)	870.24	1262.525
283 (A)	878.49	1262.525
293 (A)	878.79	1262.525
374 (B)	881.22	1242.485
384 (B)	881.52	1262.525
616 (B)	888.78	1262.525
758 (B')	892.74	1262.525

Figure 3: Plot of Occupied Bandwidth (Channel 293)

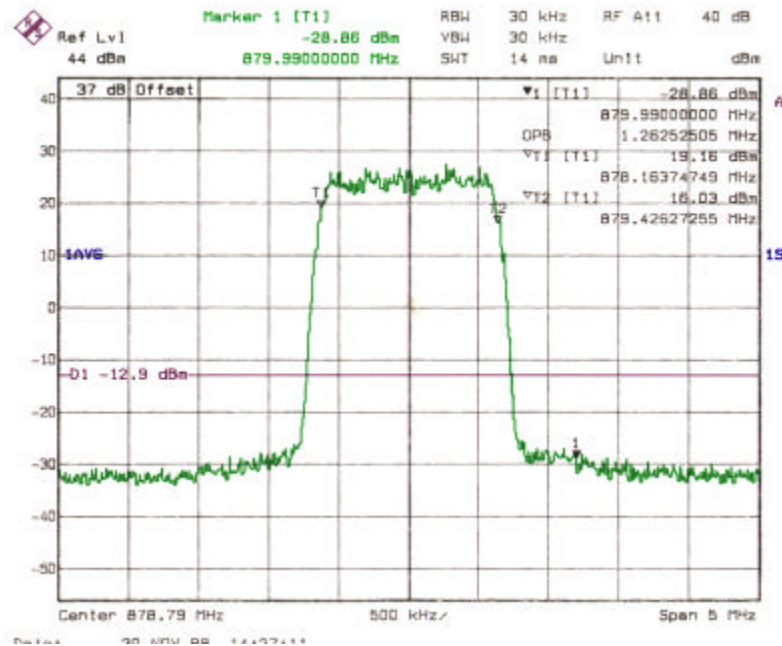

4.3 Spurious Emissions at Antenna Terminals (Digital Mode)

4.3.1 Spurious Emissions Requirements

FCC Part 2.1051

Conducted spurious emissions shall be attenuated below the level of emissions of the carrier frequency by at least $43 + 10[\log(\text{mean output power in watts})]$ or must not exceed a level of -13 dBm.

FCC Part 2.1057 - Frequency spectrum to be investigated

The spectrum should be investigated from the lowest radio generated in the equipment up to at least the 10th harmonic of the carrier frequency or to the highest frequency practicable in the present state of the art of measuring techniques, whichever is lower. Particular attention should be paid to harmonics and subharmonics of the carrier frequency. Radiation at the frequencies of multiplier stages should be checked. The amplitude of spurious emissions which are attenuated more than 20 dB below the permissible value need not be reported.

4.3.2 Test Method

The DE was setup via the BTS controller to enable the FRM to transmit at maximum power. Measurements were made on channels at the bottom, middle and top of the licensed bands.

The following spectrum analyzer settings were used for the measurement of the antenna port (DPM output) spurious emissions:

Resolution Bandwidth:	30 kHz
Video Bandwidth:	30 kHz
Video Average:	10 averages
Span:	5 MHz
Attenuation:	40 dB
Ref. Level:	44 dBm
Ref. Level Offset:	36.9 dB
Sweep Time:	Coupled

The emissions were investigated up to 10 GHz (the 10th harmonic of the fundamental emission).

4.3.3 Test Setup

The set-up used for the FRM Antenna Port (DPM) Spurious Emission test is illustrated in Figure 4.

Figure 4: Test Setup for Antenna Port Spurious Emission Measurement

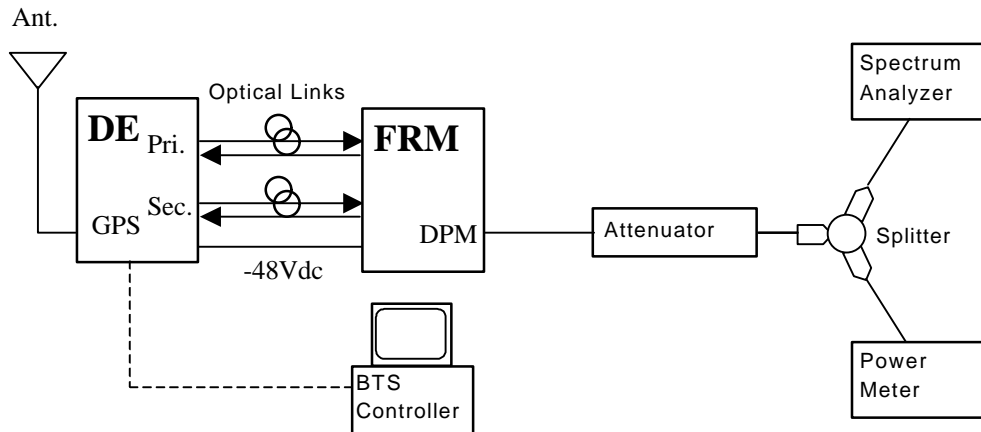

4.3.4 Test Results

The frequency spectrum from 10 MHz to 10 GHz was scanned for emissions using a 30 kHz resolution bandwidth. The FRM complies with the limit of -13 dBm. A minimum margin of 14 dB to the band edge was achieved. Table 4 shows the spurious emissions at the antenna port of the FRM. Figures 5 – 9 show the band edge emissions at the adjacent valid CDMA channel. No other out of band emissions were detected from 10 MHz to 10 GHz.

Table 4: Spurious Emissions at the 800 FRM Antenna Port

Frequency (MHz)	Spurious Emissions Level (dBm)	FCC Limit (dBm)	Margin (dB)
869.04 (lower edge of Ch. 8)	-31.41	-13	18.41
879.99 (upper edge of Ch. 293)	-28.86	-13	15.86
880.02 (lower edge of Ch. 374)	-31.14	-13	18.14
889.98 (upper edge of Ch. 616)	-29.46	-13	16.46
893.97 (upper edge of Ch. 758)	-27.21	-13	14.21

Figure 5: Spurious Emissions (Channel 8)

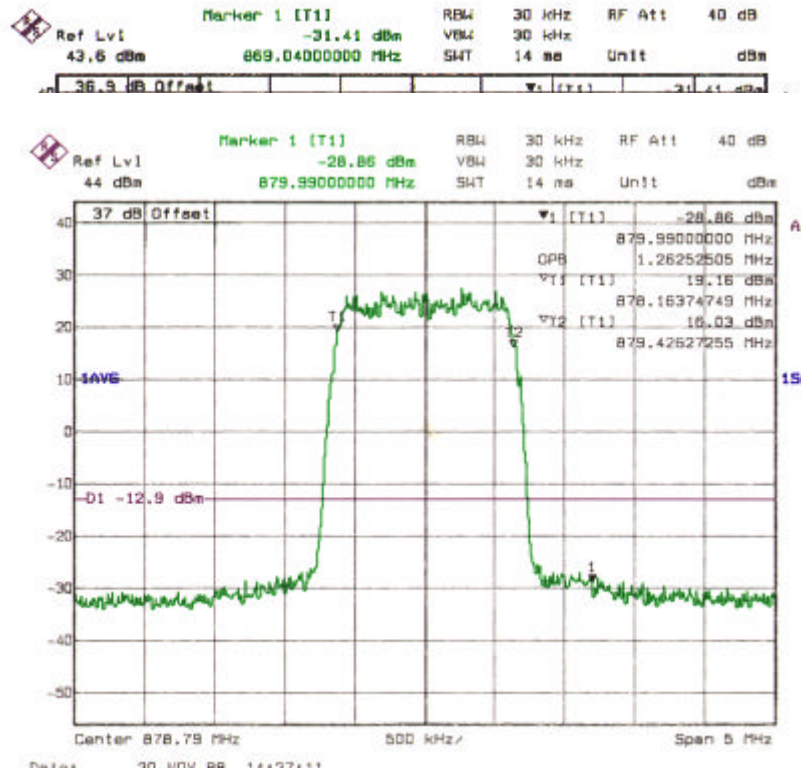

Figure 6: Spurious Emissions (Channel 293)

Figure 7: Spurious Emissions (Channel 374)

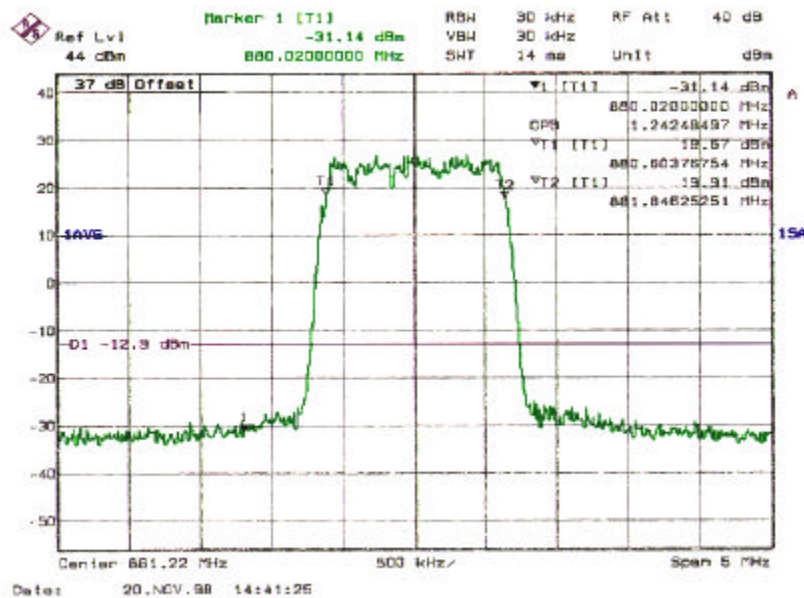

Figure 8: Spurious Emissions (Channel 616)

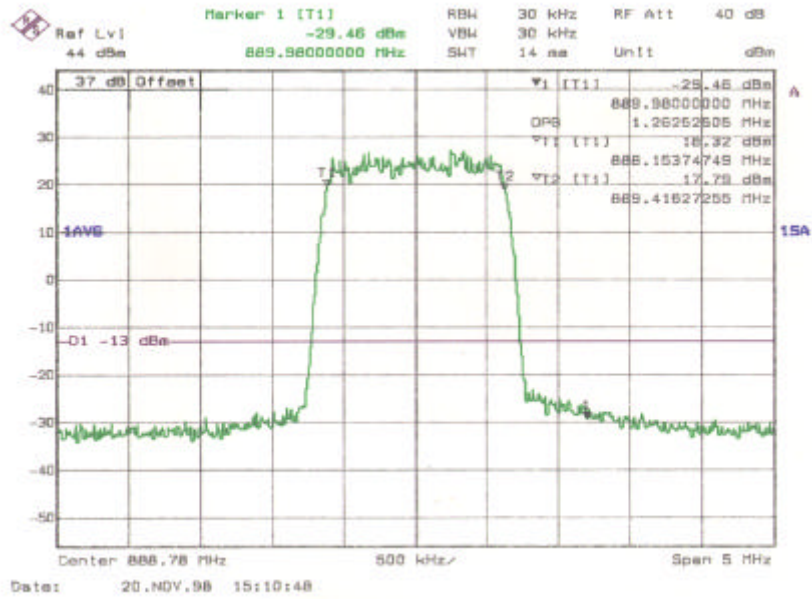
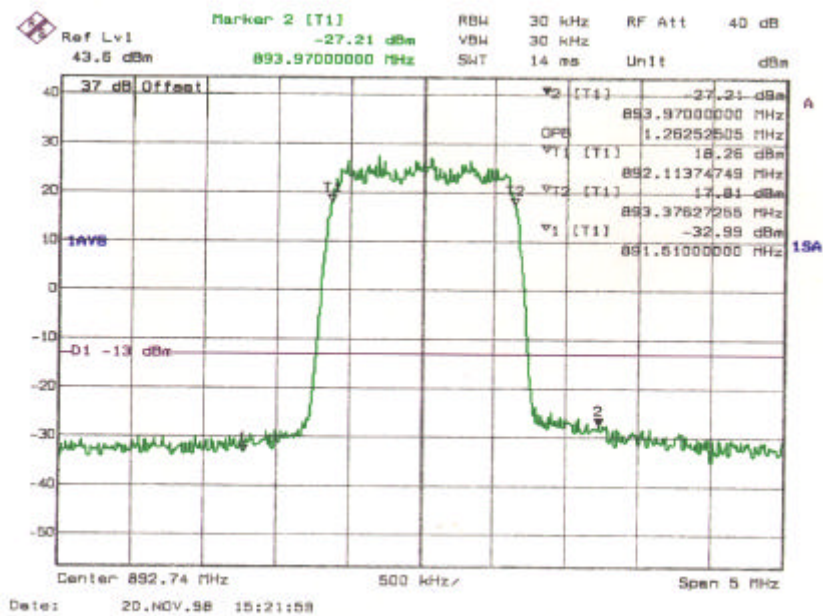

Figure 9: Spurious Emissions (Channel 758)



4.4 Frequency Stability

4.4.1 Frequency Stability Requirements

FCC Part 2.1055

(a) *The frequency stability shall be measured with variation of ambient temperature as follows:*

(1) *From -30° to $+50^{\circ}$ centigrade for all equipment except that specified in subparagraphs (2) and (3) of this paragraph.*

(b) *Frequency measurements shall be made at the extremes of the specified temperature range and at intervals of not more than 10° centigrade through the range. A period of time sufficient to stabilize all of the components of the oscillator circuit at each temperature level shall be allowed prior to frequency measurement. The short term transient effects on the frequency of the transmitter due to keying (except for broadcast transmitters) and any heating element cycling normally occurring at each ambient temperature level also shall be shown. Only the portion or portions of the transmitter containing the frequency determining and stabilizing circuitry need be subjected to the temperature variation test.*

(d) *The frequency stability shall be measured with variation of primary supply voltage as follows:*

(1) *Vary primary supply voltage from 85 to 115 percent of the nominal value for other than hand carried battery equipment.*

(2) *For hand carried, battery powered equipment, reduce primary supply voltage to the battery operating end point which shall be specified by the manufacturer.*

(3) *The supply voltage shall be measured at the input to the cable normally provided with the equipment, or at the power supply terminals if cables are not normally provided. Effects on frequency of transmitter keying (except for broadcast transmitters) and any heating element cycling at the nominal supply voltage and at each extreme also shall be shown.*

(e) *When deemed necessary, the Commission may require tests of frequency stability under conditions in addition to those specifically set out in paragraphs (a), (b), (c) and (d) of this section. (For example, measurements showing the effect of proximity to large metal objects, or of various types of antennas, may be required for portable equipment.)*

FCC Limit (Part 22.913)

The frequency stability shall be better than ± 2.5 ppm over a temperature range of -30 to $+50$ degrees C.

4.4.2 Results

The DE incorporates a GPS module from Trimble Navigation. This 10MHz GPS reference is used to synchronize the entire Base Station. The GPS module has a frequency stability of 0.8 ppb over the range of -5° C to 70° C. The Base Station complies with the requirement.

4.5 RF Radiation Exposure

An internal Nortel document, "RF Exposure Guidelines for Cellular and PCS Antenna Sites" (Document no: SI-EMR-R01.4), is used for the deployment and installation of Nortel's wireless base station equipment with respect to the control of Electromagnetic Radiation (EMR) exposure. The objective of this document is to provide guidance on where antennas can be deployed, how to calculate power densities and safe distances, and how to protect users from excessive exposure to electromagnetic radiation.

4.6 Field Strength of Spurious and Harmonic Radiation

4.6.1 Radiated Emissions Requirements

FCC Part 2.1053

(a) Measurements was made to detect spurious emissions radiated directly from the cabinet, control circuits, power leads, or intermediate circuit elements under normal conditions of installation and operation. Curves or equivalent data were supplied showing the magnitude of each harmonic and other spurious emission. For this test, single sideband, independent sideband, and controlled carrier transmitters shall be modulated under the conditions specified in paragraph 2.989(c) as appropriate. For equipment operating on frequencies below 890 MHz, an Open Field Test is normally required, with the measuring instrument antenna located in the far field at all test frequencies. In event it is either impractical or impossible to make open field measurements (e.g. a broadcast transmitter installed in a building) measurement will be accepted of the equipment as installed. Such measurements must be accompanied by a description of the site where the measurements were made showing the location of any possible source of reflections which might distort the field strength measurements. Information submitted shall include the relative radiated power of each spurious emission with the reference to the rated power output of the transmitter, assuming all emissions are radiated from half-wave dipole antennas.

(b) Measurements specified in paragraph (a) of this section shall be made for the following equipment:

- (1) Those in which the spurious emission are required to be 60 dB or more below the mean power of the transmitter.*
- (2) All equipment operating on frequencies higher than 25 MHz*
- (3) All equipment where the antenna is an integral part of, and attached directly to the transmitter.*
- (4) Other types of equipment as required, when deemed necessary by the Commission.*

FCC Part 2.1057 - Frequency spectrum to be investigated

The spectrum was investigated from the lowest radio generated in the equipment up to at least the 10th harmonic of the carrier frequency or to the highest frequency practicable in the present state of the art of measuring techniques, whichever is lower. Particular attention should be paid to harmonics and subharmonics of the carrier frequency. Radiation at the frequencies of multiplier stages should be checked. The amplitude of spurious emissions which are attenuated more than 20 dB below the permissible value need not be reported.

4.6.2 Test Method

4.6.2.1 Test Site

Radiated emissions testing was performed at Nortel's Wireless Systems Integrity Laboratory in the 10 meter Ambient Free Chamber located at 5111 47th Street NE, Calgary, Alberta Canada.

4.6.2.2 Test Procedure

Radiated emission measurements were performed according to the procedures outlined in Section 8 of the ANSI C63.4 standard.

The measurement distance between the center of the measurement antenna and the periphery of equipment under test was 10 meters.

In order to maximize all emission levels from the equipment, the emissions were searched with the receive antenna at varied height levels. The equipment was rotated a full 360 degrees on the turntable with the receive antenna at varying height levels (1 to 4 meters). Tests were made with the antenna positioned in both the horizontal and vertical planes of polarization.

The DE was setup with three FRMs transmitting on channel 283 at maximum power.

A complete scan of the emissions from 30MHz to 10 GHz was completed. Quasi-peak detector was used for measurements up to 1GHz. For emissions above 1 GHz the peak detector function was used with an RBW of 1 MHz.

4.6.3 Test Setup

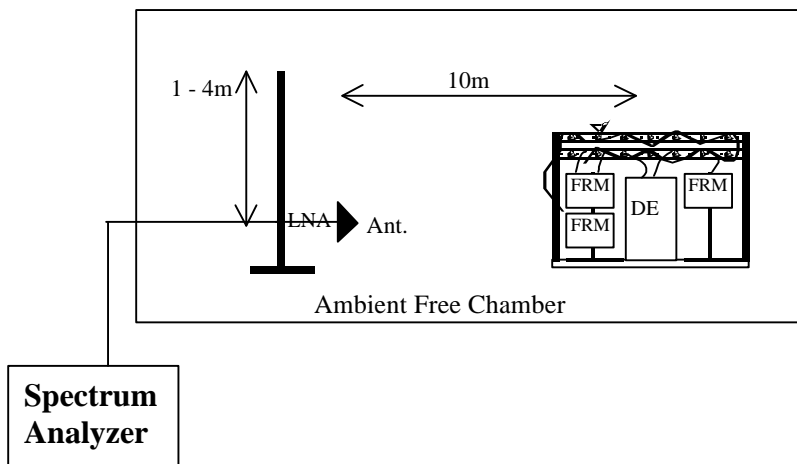

4.6.4 Test Results

There were no emissions present from the FRM within 20 dB of the FCC limit of 73.9 dB μ V/m at 10 meters.