



SANMINA-SCI

EXHIBIT 2A
Test Report
(Provided by Nortel Networks)

Applicant: Northern Telecom Ltd.

For Certification on:

AB6NT1900SFRM



Test Report for FCC Equipment Authorization

FCC ID : AB6NT1900SFRM CDMA Metro Cell 1900MHz 20.4W SFRM

Document: TR_AB6NT1900SFRM
Stream: 00
Issue: 03
Document Status: Approved
Issue Date: December 13, 2001
Security Status: Nortel Networks Confidential
Author: Michael Dawson

© 2001 Nortel Networks Limited

Disclaimer

The master of this document is stored on an electronic database and "write protected". The protection can be altered by authorized persons only. Viewing of the master document electronically ensures access to the current issue. Any hardcopies must be regarded as uncontrolled copies.

Security Warning

The information disclosed herein is proprietary to Nortel Networks and not to be used by or disclosed by unauthorized persons without the written consent of Nortel Networks. The recipient of this document shall respect the security status of the information.

PAGE INTENTIONALLY LEFT BLANK

Table of Contents

Publication History	6
List of Consultants	6
Decision Maker/Ratifier	6
Revision History	6
Acronyms and Abbreviations	7
1 Introduction.....	9
1.1 Test Result Summary	9
2 Engineering Declaration.....	10
3 Equipment Authorization Application Requirements	11
3.1 Standard Test Conditions and Test Equipment.....	11
3.2 EUT Identification List.....	11
3.3 Test Equipment List.....	11
4 Transmitter Test and Measurement Results.....	13
4.1 RF Power Output	13
4.1.1 RF Power Output Requirements	13
4.1.1 FCC Part 2.1046	13
4.1.1 FCC Limit (Part 24.232).....	13
4.1.2 Test Method	13
4.1.3 Test Setup	13
4.1.4 Test Results.....	14
4.2 Occupied Bandwidth.....	15
4.2.1 Occupied Bandwidth Requirements	15
4.2.1 FCC Part 2.1049	15
4.2.2 Test Method	15
4.2.3 Test Setup	15
4.2.4 Test Results.....	16
4.3 Spurious Emissions at Antenna Terminals	19
4.3.1 Spurious Emissions Requirements.....	19
4.3.1 FCC Part 2.1051	19
4.3.1 FCC Part 2.1057 - Frequency Spectrum to be investigated.....	20
4.3.1 FCC Part 24.238 Limit.....	20
4.3.2 Test Method	20
4.3.3 Test Setup	21
4.3.4 Test Results.....	21
4.4 Frequency Stability	39
4.4.1 Frequency Stability Requirements.....	39
4.4.1 FCC Part 2.1055	39
4.4.1 FCC Part 24.235 Limit.....	39
4.4.2 Results.....	40
References.....	41

List of Figures

Figure 1 : Test Setup for RF Power Output Measurement	13
Figure 2 : Test Setup for Occupied Bandwidth Measurement.....	16
Figure 3 : Occupied Bandwidth - DPM, Channel 150.....	18
Figure 4 : Occupied Bandwidth - Triplexer, Channel 150	19
Figure 5 : Test Setup for Spurious Emissions Measurement.....	21
Figure 6 : Conducted Spurious Emissions - DPM, Channel 25 (Adjacent 1 Mhz)	23
Figure 7 : Conducted Spurious Emissions - Triplexer, Channel 25 (Adjacent 1 Mhz).....	24
Figure 8 : Conducted Spurious Emissions - DPM, Channel 275 (Adjacent 1 Mhz)	25
Figure 9 : Conducted Spurious Emissions - DPM, Channel 1175 (Adjacent 1 Mhz)	26
Figure 10 : Conducted Spurious Emissions - DPM, Channel 25 (10 kHz - 2 GHz)	27
Figure 11 : Conducted Spurious Emissions - Triplexer, Channel 25 (10 kHz - 2 GHz)	28
Figure 12 : Conducted Spurious Emissions - DPM, Channel 25 (2 GHz - 7 GHz)	29
Figure 13 : Conducted Spurious Emissions - Triplexer, Channel 25 (2 GHz - 7 GHz)	30
Figure 14 : Conducted Spurious Emissions - DPM, Channel 25 (7 GHz - 20 GHz)	31
Figure 15 : Conducted Spurious Emissions - Triplexer, Channel 25 (7 GHz - 20 GHz)	32
Figure 16 : Conducted Spurious Emissions - DPM, Channel 275 (0 GHz - 2 GHz)	33
Figure 17 : Conducted Spurious Emissions - DPM, Channel 275 (2 GHz - 7 GHz)	34
Figure 18 : Conducted Spurious Emissions - DPM, Channel 275 (7 GHz - 20 GHz)	35
Figure 19 : Conducted Spurious Emissions - DPM, Channel 1175 (0 GHz - 2 GHz)	36
Figure 20 : Conducted Spurious Emissions - DPM, Channel 1175 (2 GHz - 7 GHz)	37
Figure 21 : Conducted Spurious Emissions - DPM, Channel 1175 (7 GHz - 20 GHz)	38

List of Tables

Table 1 : Test Results Summary	9
Table 2 : EUT Identification List.....	11
Table 3 : Test Equipment List.....	12
Table 4 : RF Output Power of 1900 MHz SFRM.....	14
Table 5 : Occupied Bandwidth Measurements 1900 MHz SFRM	16
Table 6 : Spurious Emissions at the 1900 MHz SFRM Antenna Port.....	22

Publication History

The latest controlled release of this document is located in an electronic database. **All other soft and hard copies are uncontrolled.** It is the responsibility of the reader to ensure that the latest release of this document is being used.

List of Consultants

The following people have reviewed this document prior to its release and have recommended its approval:

Printed Name	Function	Department
James Loo	CDMA BTS RF Systems	2M64
Borislav Todorov	CDMA BTS RF Systems	2M64
Pierre Melancon	CDMA BTS RF Systems	2M64

Decision Maker/Ratifier

The release of this document has been reviewed and approved for distribution and use by the following:

Ratifier's Name	Signature	Date
Radu Trandafir	via email	December 13, 2001

Revision History

Stream/issue	Revision Date	Reason for Change	Author
00/01	10/12/2001	Initial test report	Michael Dawson Borislav Todorov
00/02	12/12/2001	Minor changes as per reviewer comments Approved for release	Michael Dawson
00/03	13/12/2001	Minor changes per Sanmina comments	Michael Dawson

Change bars are not used in this document.

Acronyms and Abbreviations

ASIC	Application Specific Integrated Circuit
BBW	Breathing, Blossoming and Wilting
BPF	Bandpass Filter
BTS	Base Station Transceiver Subsystem
BW	Bandwidth
CDMA	Code Division Multiple Access
dBFS	dB relative to Full Scale
DDS	Direct Digital Synthesizer
DPM	Duplexer Preselector Module
EEPROM	Electrically Erasable and Programmable ROM
EC	Engineering Change
ERLCE	Excess Reverse Link Capacity Estimate
HSSPC	High-Speed Serial Protocol Controller
HW	Hardware
IF	Intermediate Frequency
IIC	Inter-Integrated Circuit Bus
IS	Interim Standard
LO	Local Oscillator
LPF	Lowpass Filter
MCPA	Multi-Carrier Power Amplifier
NF	Noise Figure
OCNS	Orthogonal Channel Noise Source
OH	OverHead
PA	Power Amplifier
PC	Personal Computer
PPR	Peak Power Reduction
PSA	Product Specification Agreement
RBW	Resolution BandWidth
RF	Radio Frequency
Rx	Receive

SA	Spectrum Analyzer
SFRM	Single Carrier Flexible Radio Module
SW	Software
TBD	To Be Determined
TM	Triplexer Module
TPTL	Transmit Power Tracking Loop
TRM	Transmitter Receiver Module
Tx	Transmit
uP	Microprocessor
XCVR	Transceiver

1 Introduction

This test report is submitted in accordance with the FCC Rules and Regulations, Part 2, Subpart J, Sections 2.1046 through 2.1057 for equipment authorization of Northern Telecom's (Nortel Networks) CDMA 1900 MHz Single carrier Flexible Radio Module (SFRM).

The 1900 MHz SFRM is intended for use in the Domestic Public Cellular Radio Telecommunications Service and is designed in accordance with the following standards:

- *CFR 47, Part 24, Subpart E, Broadband Personal Communications Service [1]*
- *CFR 47, Part 2, Subpart J, Equipment Authorization Procedures - Equipment Authorization[2]*

1.1 Test Result Summary

Table 1 summarizes the measurement results¹ for the CDMA 1900 MHz SFRM.

Table 1 : Test Results Summary

FCC Measurement Specification	FCC Limit Specification	Description	Results
2.1046	24.232	RF Power Output	Compliant
2.1047		Modulation Characteristics	Not Applicable
2.1049		Occupied Bandwidth	OBW = 1.2725 MHz
2.1051, 2.1057	24.238	Spurious Emissions at Antenna Terminals	Compliant
2.1055	24.235	Frequency Stability	Compliant

1. This report presents measurement results for tests performed by Nortel Networks. Field Strength of Spurious Emissions measurement results along with requirements specified in 2.1033 are covered in a separate test report from Sanmina Canada.

2 Engineering Declaration

The CDMA 1900MHz Single carrier Flexible Radio Module has been tested in accordance with the requirements contained in the Federal Communications Commission Rules and Regulations Part 2 and 24.

To the best of my knowledge, these tests were performed in accordance with good engineering practices using measurement procedures consistent with industry or commission standards or previous Commission correspondence or guidance and demonstrate that this equipment complies with the appropriate standards. All tests were conducted on a representative sample of the equipment for which type acceptance/certification is sought.

Tested By:

Michael Dawson
Systems Designer
Nortel Networks
Ottawa, Canada

Signature

Dec 12/2001
Date

Reviewed By:

Borislav Todorov
Systems Designer
Nortel Networks
Ottawa, Canada

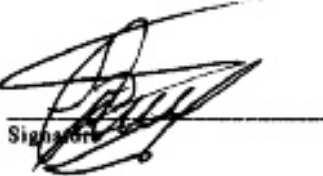
Signature

Dec. 12. 101
Date

Approved By:

Pierre Melancon
Senior Systems Engineer
Nortel Networks
Ottawa, Canada

Signature

Dec 12, 2001
Date

3 Equipment Authorization Application Requirements

3.1 Standard Test Conditions and Test Equipment

The SFRM was tested under the following standard test conditions unless otherwise noted:

- Ambient Temperature: 20 to 35 degrees C
- Ambient Humidity: 20 to 40%
- DC Supply Voltage: -48 Vdc (nominal)

3.2 EUT Identification List

Table 2 shows the identification of the components tested in this report.

Table 2 : EUT Identification List

Equipment Description	Model / Part Number	Release Number	Serial Number
1900 MHz Single carrier Flexible Radio Module (comprised of the main modules below)	N/A	N/A	N/A
a) 1900 TRM	NTGS58CA	31	NNTM53712EYT
b) 1900 PAM	NTGS57AA	BB	NNTM535LKU2C
c) A/D Band DPM	NTGS53JA	05	CLWVCC10083X
d) B/E Band DPM	NTGS53KA	05	CLWVPP201L4U
e) C/F Band DPM	NTGS53LA	06	CLWVPP20422P
f) Upper A/D Band Triplexer	NTGS5302	0D	FORM01018780

3.3 Test Equipment List

Table 3 shows the identification of the test equipment used in this report.

Table 3 : Test Equipment List

Description	Manufacturer	Model	Serial Number	Cal. Due Date
9kHz to 26.5 GHz Spectrum Analyzer	Rohde&Schwarz	FSEM-30	830843/006	Nov-23-02
RF Power Meter	HP	E4419B	1VS39250616	Dec-14-01
RF Power Sensor Head	HP	8482A	3318A29773	Aug-02-02
30dB Attenuator	Narda	776B-30	5280	Verified
RF Cable	Huber+Suhner	Sucoflex 104PE	2972/4PE	Verified

4 Transmitter Test and Measurement Results

4.1 RF Power Output

4.1.1 RF Power Output Requirements

FCC Part 2.1046

(a) For transmitters other than single sideband, independent sideband and controlled carrier radiotelephone, power output shall be measured at the RF output terminals when the transmitter is adjusted in accordance with the tune -up procedure to give the values of current and voltage on the circuit elements specified in 2.983(d)(5). The electrical characteristics of the radio frequency load attached to the output terminals when this test is made shall be stated.

FCC Limit (Part 24.232)

The maximum RF power from a base station must not exceed 100 Watts.

4.1.2 Test Method

The DE was setup via the BTS controller to enable the SFRM to transmit at maximum power. Measurements were made on channels at the bottom, middle and top of the licensed bands. The RF output power was measured using the power meter.

4.1.3 Test Setup

The set-up used for the SFRM RF output power test is illustrated in Figure 1. RF output power measurements were referenced to the antenna port of the DPM/TM.

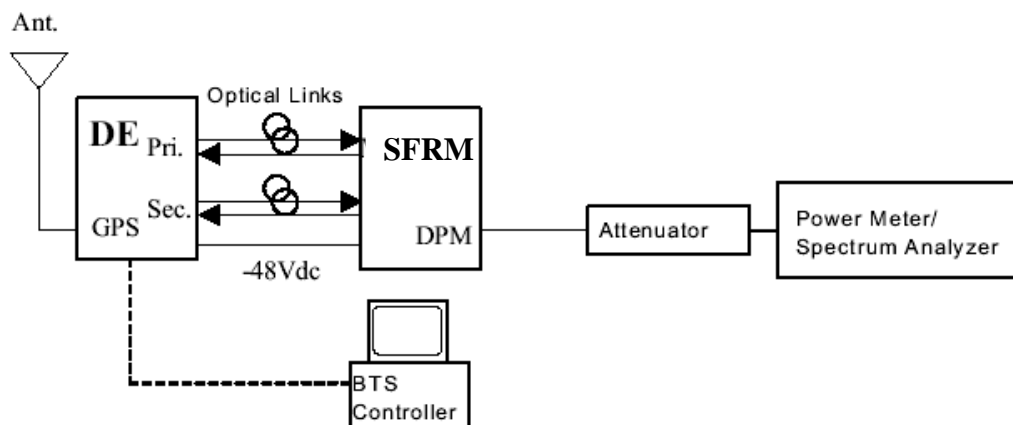

Figure 1 : Test Setup for RF Power Output Measurement

4.1.4 Test Results

The 1900 MHz SFRM complies with the requirement. The maximum measured RF output power from the SFRM was 42.10 dBm. The RF power output measured on the bottom, middle and top channels of each licensed band is shown in Table 4. Channels in the A and D bands were tested using both the A/D DPM and Upper A/D Triplexer. Channels in the B and E bands were tested using the B/E DPM. Channels in the C and F bands were tested using the C/F DPM.

Table 4 : RF Output Power of 1900 MHz SFRM

Channel Number (Band)	Frequency (MHz)	Measured RF Output Power (dBm)	Maximum Rated Power (dBm)	FCC Limit (dBm)
25 (A)	1931.25	41.89	42.3	50
25 (A) ^a	1931.25	41.49	42.3	50
150 (A)	1937.50	42.02	42.3	50
150 (A) ^a	1937.50	41.51	42.3	50
275 (A)	1943.75	42.08	42.3	50
275 (A) ^a	1943.75	41.58	42.3	50
325 (D)	1946.25	42.04	42.3	50
325 (D) ^a	1946.25	41.67	42.3	50
350 (D)	1947.50	42.04	42.3	50
350 (D) ^a	1947.50	41.68	42.3	50
375 (D)	1948.75	42.07	42.3	50
375 (D) ^a	1948.75	41.70	42.3	50
425 (B)	1951.25	42.01	42.3	50
550 (B)	1957.50	42.05	42.3	50
675 (B)	1963.75	42.08	42.3	50
725 (E)	1966.25	42.03	42.3	50
750 (E)	1967.50	42.05	42.3	50
775 (E)	1968.75	42.07	42.3	50
825 (F)	1971.25	42.06	42.3	50
850 (F)	1972.50	42.06	42.3	50
875 (F)	1973.75	42.06	42.3	50

Channel Number (Band)	Frequency (MHz)	Measured RF Output Power (dBm)	Maximum Rated Power (dBm)	FCC Limit (dBm)
925 (C)	1976.25	42.10	42.3	50
1050 (C)	1982.50	42.10	42.3	50
1175 (C)	1988.75	42.08	42.3	50

a. Channels measured using the Upper A/D Band Triplexer.

4.2 Occupied Bandwidth

4.2.1 Occupied Bandwidth Requirements

FCC Part 2.1049

The OBW, that is the frequency bandwidth such that, below its lower and above its upper frequency limits, the mean powers radiated are each equal to 0.5 percent of the total mean power radiated by a given emission shall be measured under the following conditions as applicable:

(g) Transmitter in which the modulating baseband comprises not more than three independent channels - when modulated by the full complement of signals for which the transmitter is rated. The level of modulation for each channel should be set to that prescribed in rule parts applicable to the services for which the transmitter is intended. If specific modulation levels are not set forth in the rules, the tests should provide the manufacturer's maximum rated condition.

(h) Transmitters employing digital modulation techniques - when modulated by an input signal such that its amplitude and symbol rate represent the maximum rated conditions under which the equipment will be operated. The signal shall be applied through any filter networks, pseudo-random generators or other devices required in normal service. Additionally, the occupied bandwidth shall be shown for operation with any devices used for modifying the spectrum when such devices are optional at discretion of the user.

4.2.2 Test Method

The DE was setup via the BTS controller to enable the SFRM to transmit at maximum power. Measurements were made on channels at the bottom, middle and top of each of the licensed bands. The occupied bandwidth was measured using the 99% channel power feature of the spectrum analyzer.

4.2.3 Test Setup

The set-up used for the SFRM Occupied bandwidth test is illustrated in Figure 2.

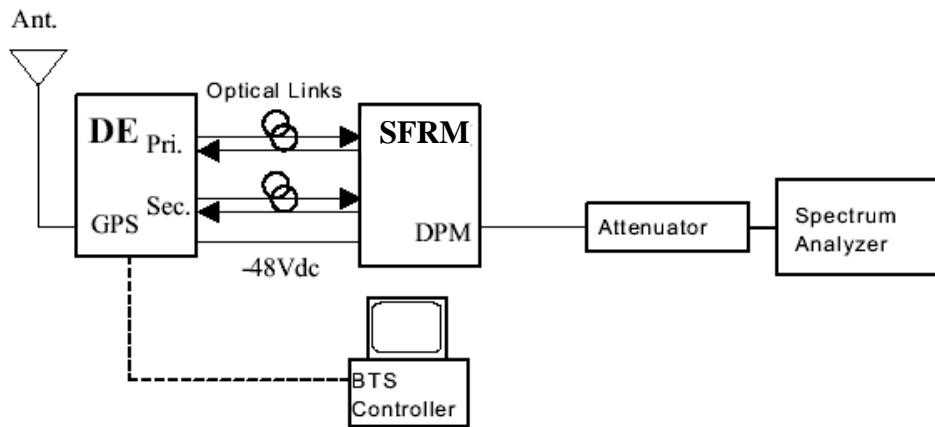

Figure 2 : Test Setup for Occupied Bandwidth Measurement

4.2.4 Test Results

The 1900 MHz SFRM complies with the requirement. The maximum measured occupied bandwidth from the SFRM was 1272.50 kHz. The occupied bandwidth measured on the bottom, middle and top channels of each licensed band is shown in Table 5. Figures 3 and 4 show plots of the maximum measured occupied bandwidths of 1272.50 kHz for the DPM and Triplexer respectively. Channels in the A and D bands were tested using both the A/D DPM and Upper A/D Triplexer. Channels in the B and E bands were tested using the B/E DPM. Channels in the C and F bands were tested using the C/F DPM.

Table 5 : Occupied Bandwidth Measurements 1900 MHz SFRM

Channel Number (Band)	Frequency (MHz)	Measured Occupied Bandwidth (kHz)
25 (A)	1931.25	1262.50
25 (A) ^a	1931.25	1262.50
150 (A)	1937.50	1272.50
150 (A) ^a	1937.50	1272.50
275 (A)	1943.75	1272.50
275 (A) ^a	1943.75	1272.50
325 (D)	1946.25	1272.50
325 (D) ^a	1946.25	1272.50

Channel Number (Band)	Frequency (MHz)	Measured Occupied Bandwidth (kHz)
350 (D)	1947.50	1272.50
350 (D) ^a	1947.50	1272.50
375 (D)	1948.75	1262.50
375 (D) ^a	1948.75	1272.50
425 (B)	1951.25	1272.50
550 (B)	1957.50	1272.50
675 (B)	1963.75	1272.50
725 (E)	1966.25	1272.50
750 (E)	1967.50	1272.50
775 (E)	1968.75	1272.50
825 (F)	1971.25	1272.50
850 (F)	1972.50	1272.50
875 (F)	1973.75	1262.50
925 (C)	1976.25	1272.50
1050 (C)	1982.50	1262.50
1175 (C)	1988.75	1272.50

a. Channels measured using the Upper A/D Band Triplexer.

Figure 3 : Occupied Bandwidth - DPM, Channel 150

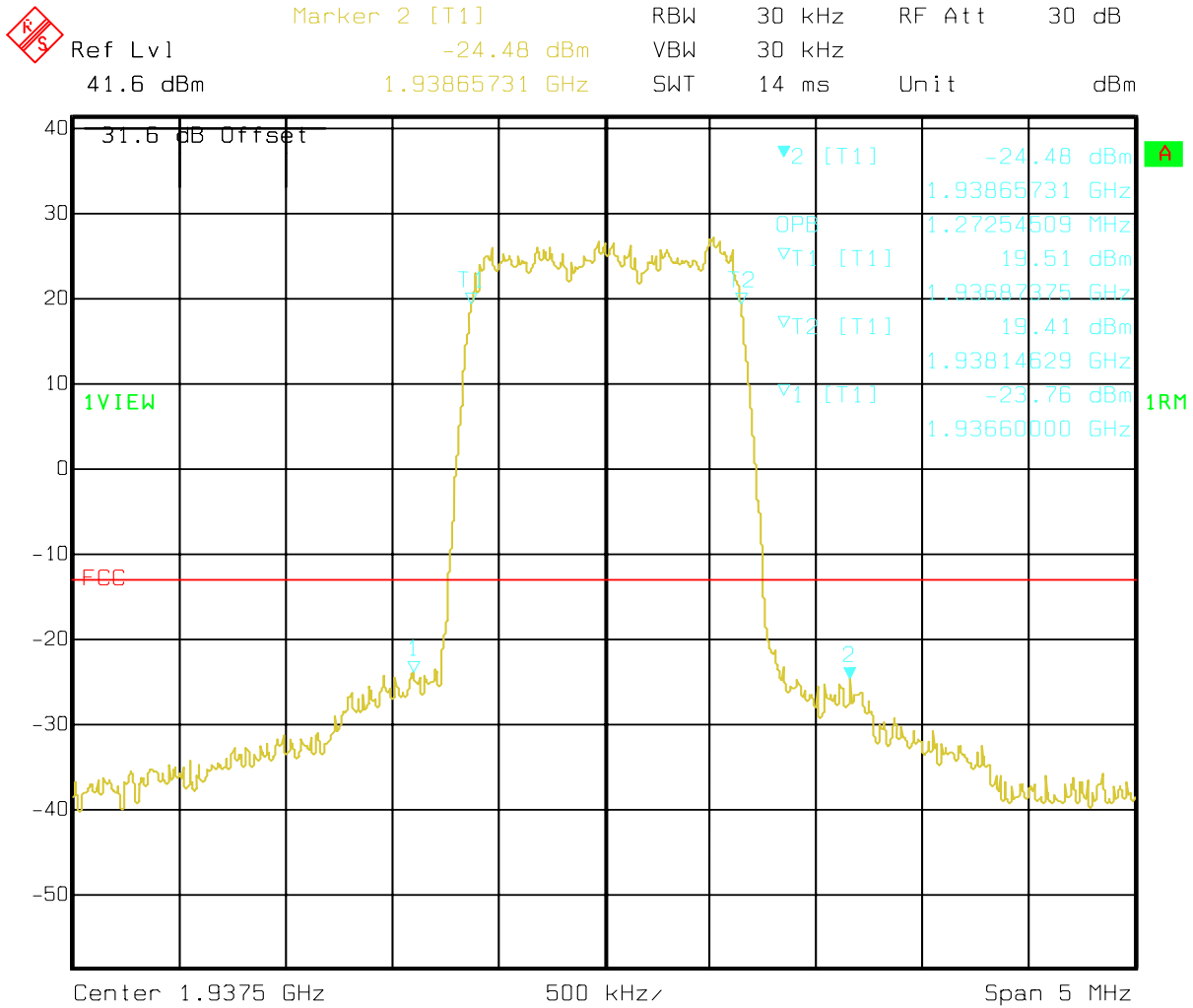

Title: OCCUPIED BANDWIDTH
 Comment A: FCC ID: AB6NT1900SFRM. CDMA 1900 SFRM CHANNEL 150
 Date: 30.NOV.2001 17:38:29

Figure 4 : Occupied Bandwidth - Triplexer, Channel 150

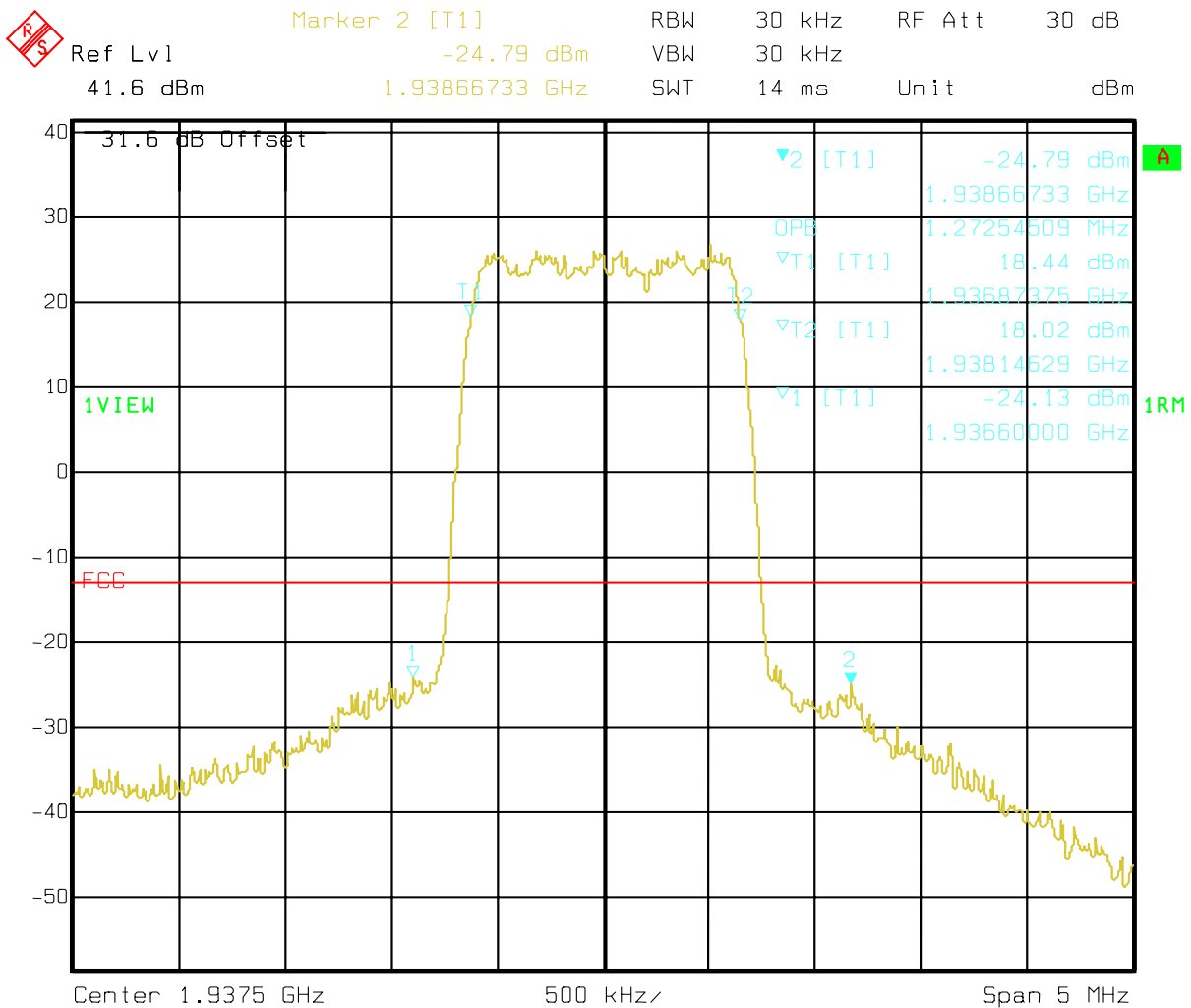

Title: OCCUPIED BANDWIDTH
 Comment A: FCC ID: AB6NT1900SFRM. CDMA 1900 SFRM UPPER A/D TRIPLEXER :
 CHANNEL 150
 Date: 2.DEC.2001 20:54:04

4.3 Spurious Emissions at Antenna Terminals

4.3.1 Spurious Emissions Requirements

FCC Part 2.1051

The radio frequency voltage or powers generated within the equipment and appearing on a spurious frequency shall be checked at the equipment output terminals when properly loaded with a suitable artificial antenna. Curves or equivalent data shall show the magnitude of each harmonic and other spurious emission that can be detected when the equipment is operated under the conditions specified in 2.1049 as appropriate. The

magnitude of spurious emissions which are attenuated more than 20 dB below the permissible value need not be specified.

FCC Part 2.1057 - Frequency Spectrum to be investigated

The spectrum should be investigated from the lowest radio frequency generated in the equipment up to at least the 10th harmonic of the carrier frequency or to the highest frequency practicable in the present state of the art of measuring techniques, whichever is lower. Particular attention should be paid to harmonics and subharmonics of the carrier frequency. Radiation at the frequencies of multiplier stages should be checked. The amplitude of spurious emissions which are attenuated more than 20 dB below the permissible value need not be reported.

FCC Part 24.238 Limit

(a) On any frequency outside a licensee's frequency block, the power of any emission shall be attenuated below the transmit power (P) by at least $43 + 10 \log (P)$ dB.

(b) Compliance with these provisions is based on the use of measurement instrumentation employing a resolution bandwidth of 1 MHz or greater. However, in the 1 MHz bands immediately outside and adjacent to the frequency block a resolution bandwidth of at least one percent of the emission bandwidth of the fundamental emission of the transmitter may be employed. The emission bandwidth is defined as the width of the signal between two points, one below the carrier center frequency and one above the carrier center frequency, outside of which all emissions are attenuated at least 26 dB below the transmitter power.

(c) When measuring the emission limits, the nominal carrier frequency shall be adjusted as close to the licensee's frequency block edges, both upper and lower, as the design permits.

(d) The measurements of emission power can be expressed in peak or average values, provided they are expressed in the same parameters as the transmitter power.

4.3.2 Test Method

The BTS digital enclosure was configured via the BTS controller to enable the SFRM to transmit at maximum power. Measurements were made on channels at the bottom, middle and top of the licensed bands. The following spectrum analyzer settings were used for the measurement of the antenna port (DPM/Triplexer output) spurious emissions:

Adjacent 1MHz to indicated cellular band (Upper and Lower)

Resolution Bandwidth:	30 kHz
Video Bandwidth:	30 kHz
Video Average:	10 Averages
Span:	1 MHz
Attenuation:	30 dB

Ref. Level: 41.6 dBm
Ref. Level Offset: 31.6 dB

All spectrum analyzer settings were coupled as per the manufacturers recommendations to improve measurement time, without compromising data.

All other Spurious Emissions up to 20 GHz

Resolution Bandwidth: 1 MHz
Video Bandwidth: 1 MHz
Video Average: 10 Averages
Span: Set accordingly
Attenuation: 30 dB
Ref. Level: 41.6 dBm
Ref. Level Offset: 31.6 dB

4.3.3 Test Setup

The set-up used for the SFRM Antenna Port (DPM/Triplexer) Spurious Emission test is illustrated in Figure 5.

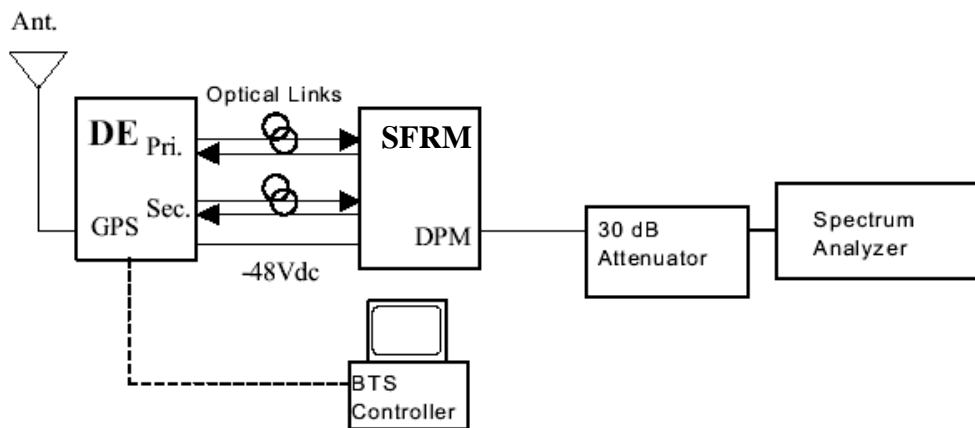

Figure 5 : Test Setup for Spurious Emissions Measurement

4.3.4 Test Results

The frequency spectrum from 1 MHz to 20 GHz was scanned for emissions using the spectrum analyzer settings outlined in the test method (Section 4.3.2). The SFRM complies with the limit of -13 dBm. Table 6 shows the spurious emissions at the antenna port of the SFRM.

Table 6 : Spurious Emissions at the 1900 MHz SFRM Antenna Port

Frequency (MHz)	Spurious Emissions Level (dBm)	Limit (dBm)	Margin (dB)
1930.00 (lower edge of band A)	-28.63 (1st Adjacent MHz)	-13	15.63
1944.95 (upper edge of band A)	-27.02 (1st Adjacent MHz)	-13	14.02
1930.00 (lower edge of band A) ^a	-29.32 (1st Adjacent MHz)	-13	16.32
1944.95 (upper edge of band A) ^a	-27.02(1st Adjacent MHz)	-13	14.02
1945.00 (lower edge of band D)	-28.73 (1st Adjacent MHz)	-13	15.73
1949.95 (upper edge of band D)	-26.98 (1st Adjacent MHz)	-13	13.98
1945.00 (lower edge of band D) ^a	-29.71 (1st Adjacent MHz)	-13	16.71
1949.95 (upper edge of band D) ^a	-27.34 (1st Adjacent MHz)	-13	14.32
1950.00 (lower edge of band B)	-28.15 (1st Adjacent MHz)	-13	15.15
1964.95 (upper edge of band B)	-29.18 (1st Adjacent MHz)	-13	16.18
1965.00 (lower edge of band E)	-29.39 (1st Adjacent MHz)	-13	16.39
1969.95 (upper edge of band E)	-30.20 (1st Adjacent MHz)	-13	17.20
1970.00 (lower edge of band F)	-30.28 (1st Adjacent MHz)	-13	17.28
1974.95 (upper edge of band F)	-27.85 (1st Adjacent MHz)	-13	14.85
1975.00 (lower edge of band C)	-30.48 (1st Adjacent MHz)	-13	17.48
1989.95 (upper edge of band C)	-25.63 (1st Adjacent MHz)	-13	12.63
0 - 2000	-29.08	-13	16.08
2000 - 7000	-23.58	-13	10.58
7000 - 20000	-25.67	-13	12.67

a. Channels measured using the Upper A/D Band Triplexer.

Notes:

1. Figure 6 and Figure 7 show sample plots for the case when the transmitter was tuned to Channel 25 (lowest channel in Tx band).
2. Figure 8 shows a sample plot for the case when the transmitter was tuned to Channel 275 (highest channel in A band).
3. Figure 9 shows a sample plot for the case when the transmitter was tuned to Channel 1175 (highest channel in Tx band).
4. Figures 10 through 21 show sample plots for frequency spans from 0 to 20 GHz for cases when the transmitter was tuned to Channels 25, 275 and 1175.

Figure 6 : Conducted Spurious Emissions - DPM, Channel 25 (Adjacent 1 Mhz)

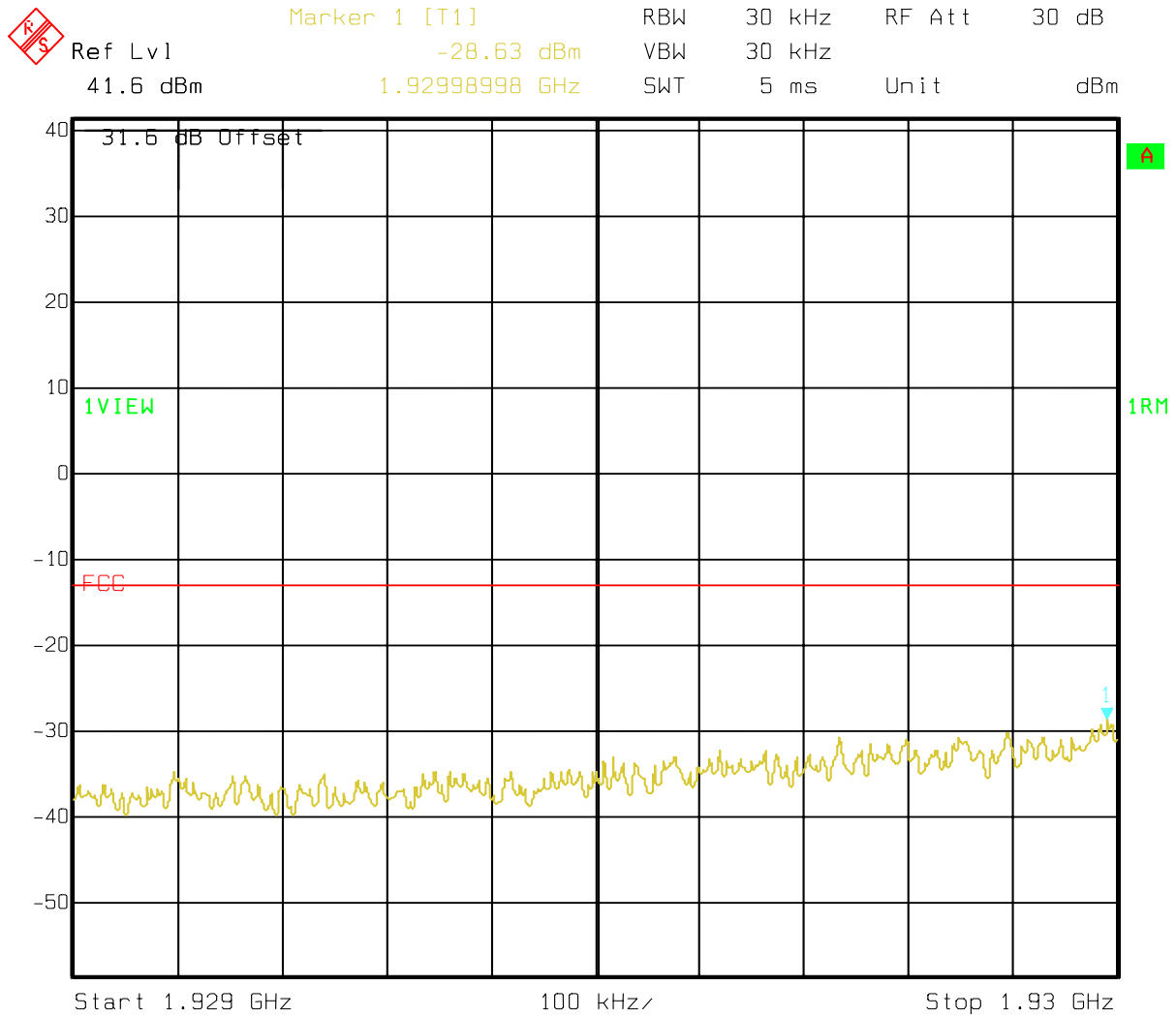

Title: SPURIOUS EMISSIONS AT ANTENNA PORT
 Comment A: FCC ID: AB6NT1900SFRM. CDMA 1900 SFRM CHANNEL 25
 Date: 30.NOV.2001 17:26:52

Figure 10 : Conducted Spurious Emissions - DPM, Channel 25 (10 kHz - 2 GHz)

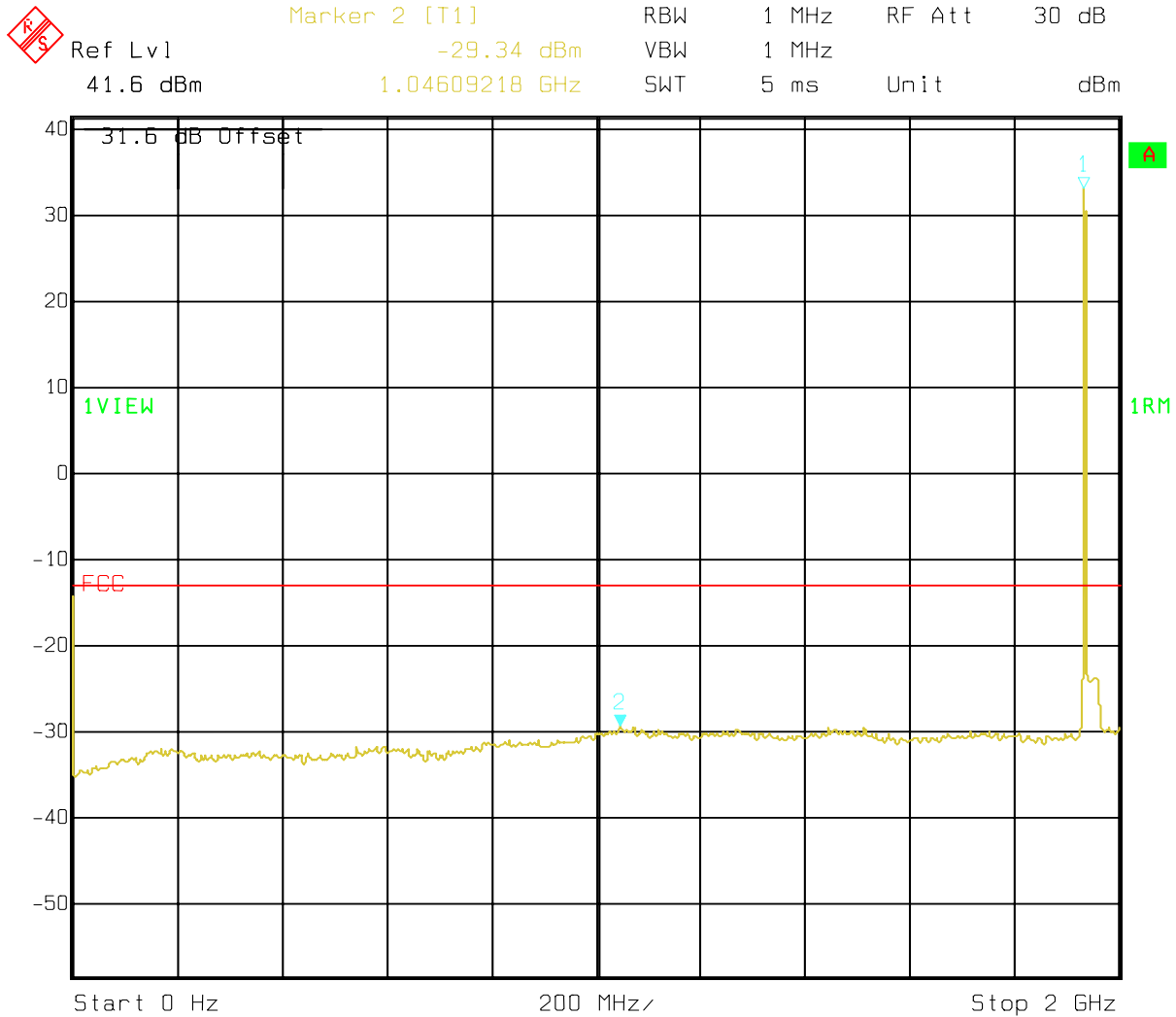

Title: SPURIOUS EMISSIONS AT ANTENNA PORT
 Comment A: FCC ID: AB6NT1900SFRM. CDMA 1900 SFRM CHANNEL 25
 Date: 30.NOV.2001 17:25:56

Figure 11 : Conducted Spurious Emissions - Triplexer, Channel 25 (10 kHz - 2 GHz)

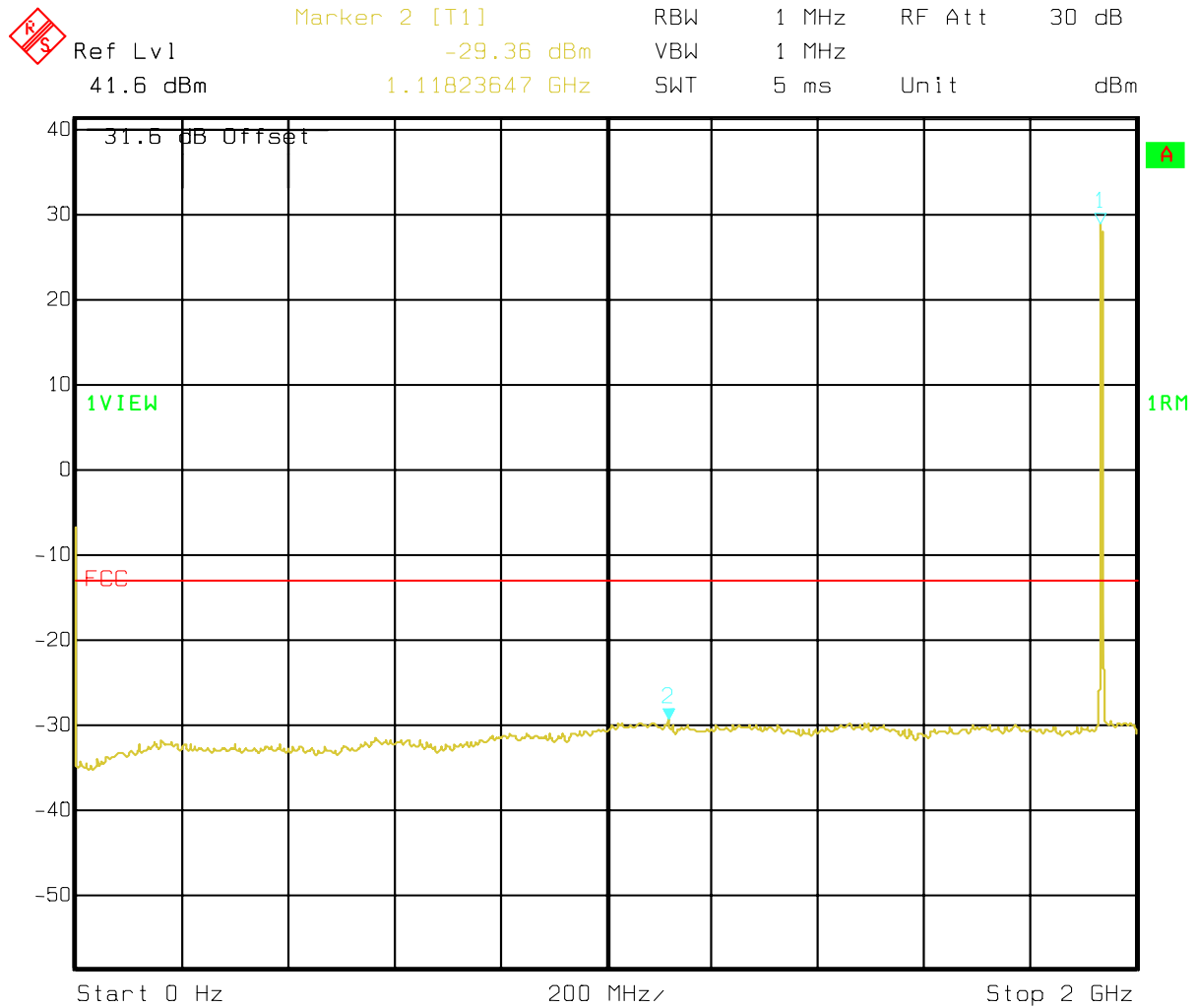

Title: SPURIOUS EMISSIONS AT ANTENNA PORT
 Comment A: FCC ID: AB6NT1900SFRM. CDMA 1900 SFRM UPPER A/D TRIPLEXER :
 CHANNEL 25
 Date: 2.DEC.2001 21:59:35

Figure 12 : Conducted Spurious Emissions - DPM, Channel 25 (2 GHz - 7 GHz)

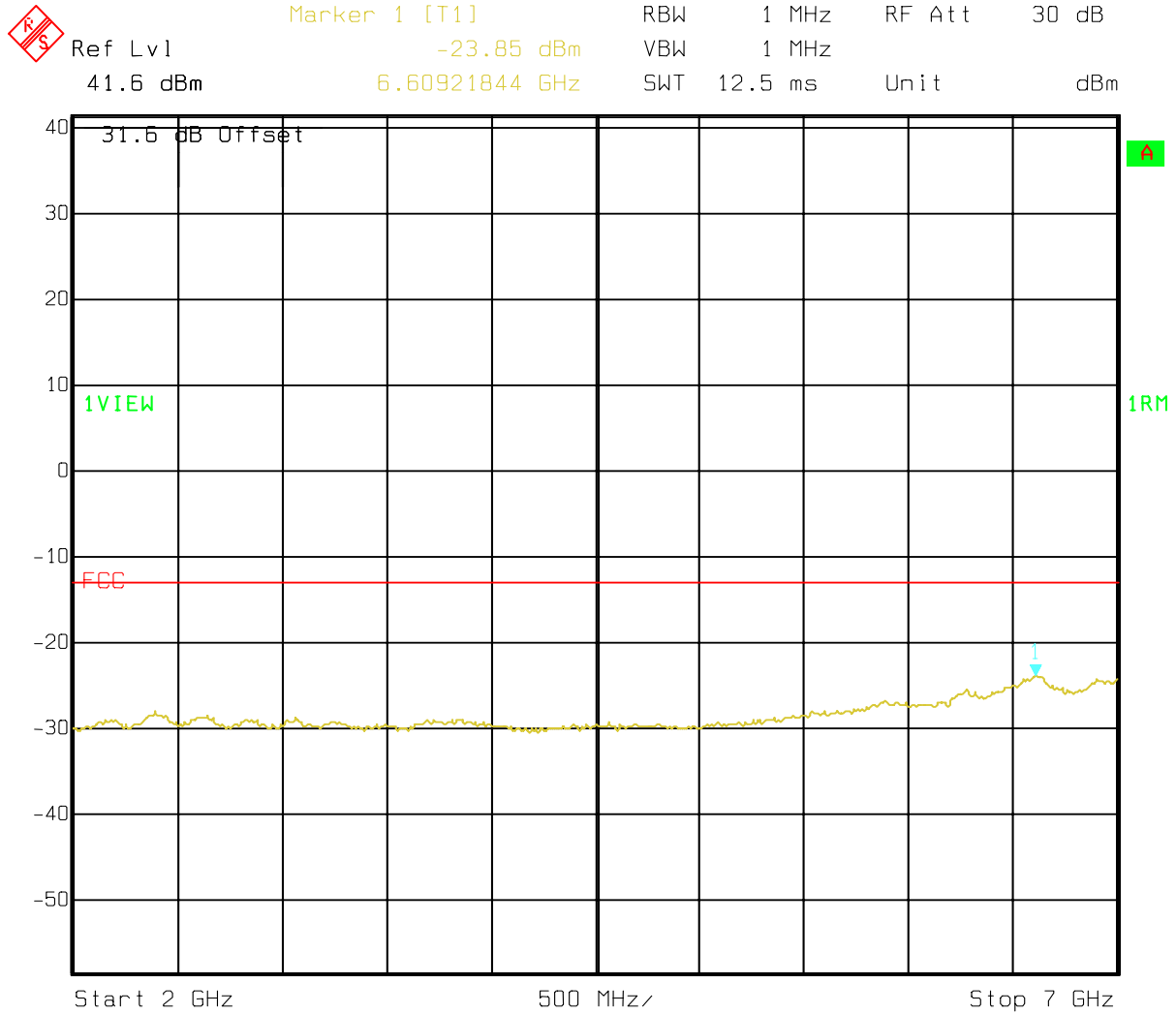

Title: SPURIOUS EMISSIONS AT ANTENNA PORT
 Comment A: FCC ID: AB6NT1900SFRM. CDMA 1900 SFRM CHANNEL 25
 Date: 30.NOV.2001 17:26:14

Figure 13 : Conducted Spurious Emissions - Triplexer, Channel 25 (2 GHz - 7 GHz)

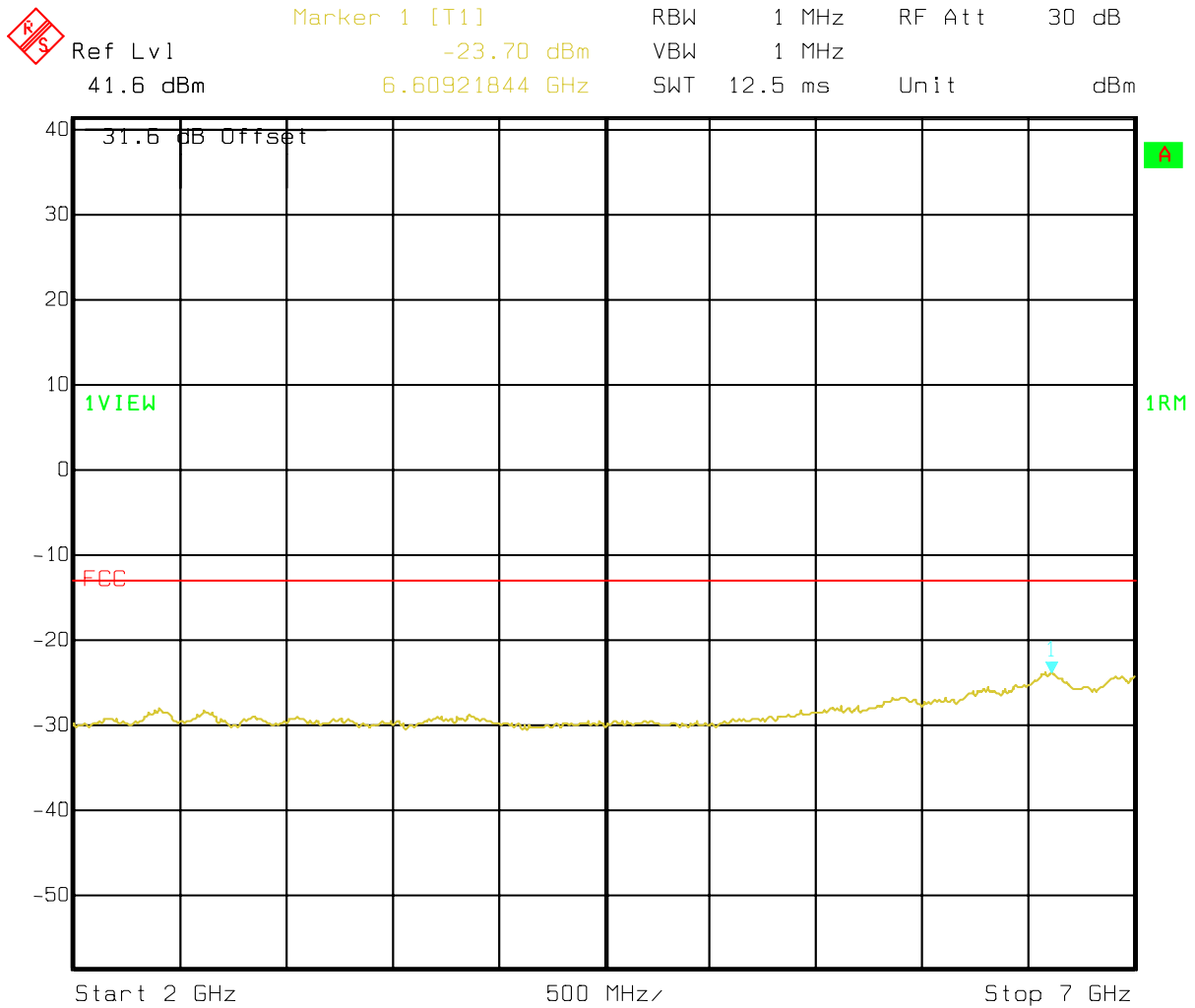

Title: SPURIOUS EMISSIONS AT ANTENNA PORT
 Comment A: FCC ID: AB6NT1900SFRM. CDMA 1900 SFRM UPPER A/D TRIPLEXER :
 CHANNEL 25
 Date: 2.DEC.2001 21:59:53

Figure 17 : Conducted Spurious Emissions - DPM, Channel 275 (2 GHz - 7 GHz)

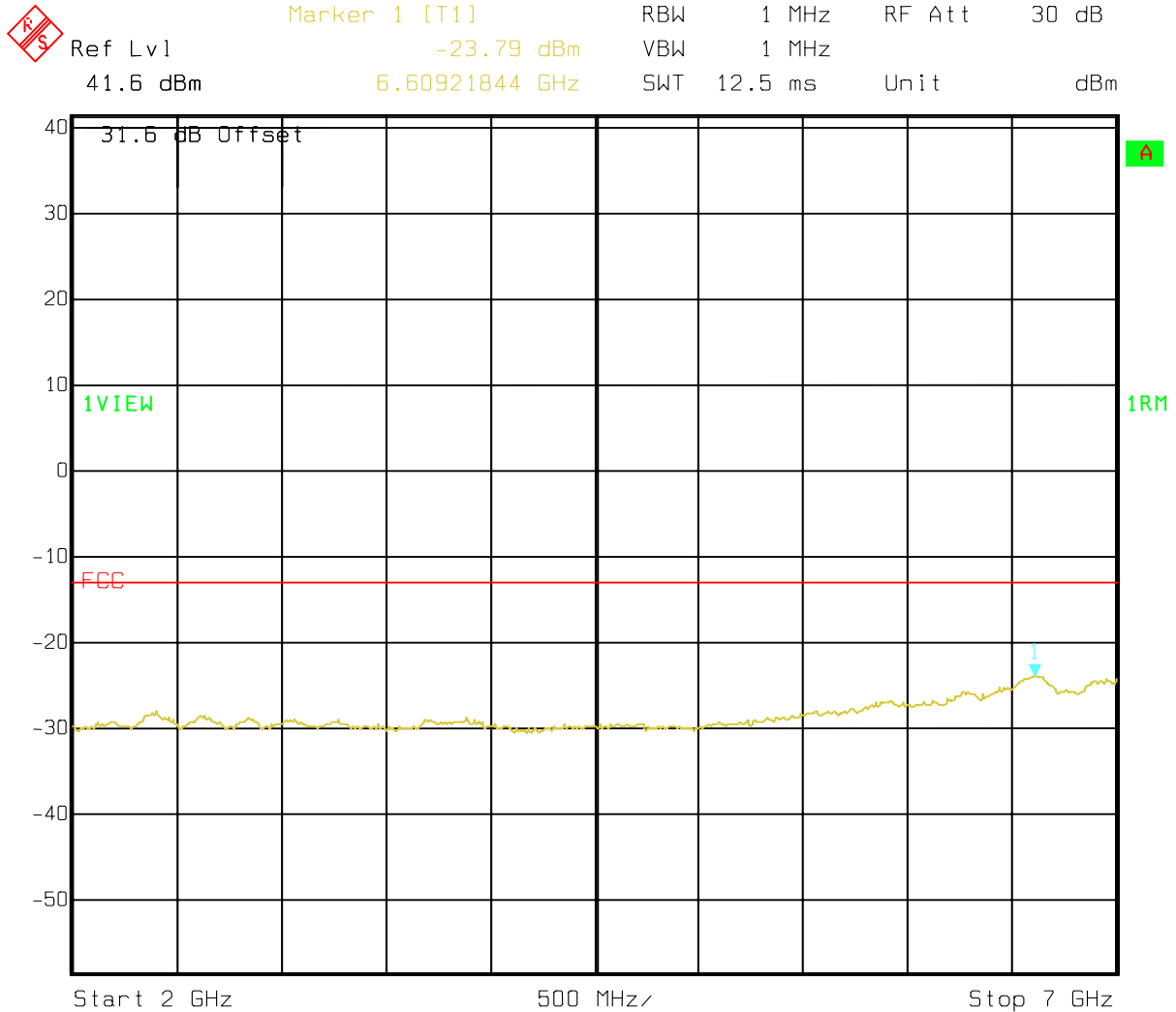

Title: SPURIOUS EMISSIONS AT ANTENNA PORT
 Comment A: FCC ID: AB6NT1900SFRM. CDMA 1900 SFRM CHANNEL 275
 Date: 30.NOV.2001 17:51:02

Figure 19 : Conducted Spurious Emissions - DPM, Channel 1175 (0 GHz - 2 GHz)

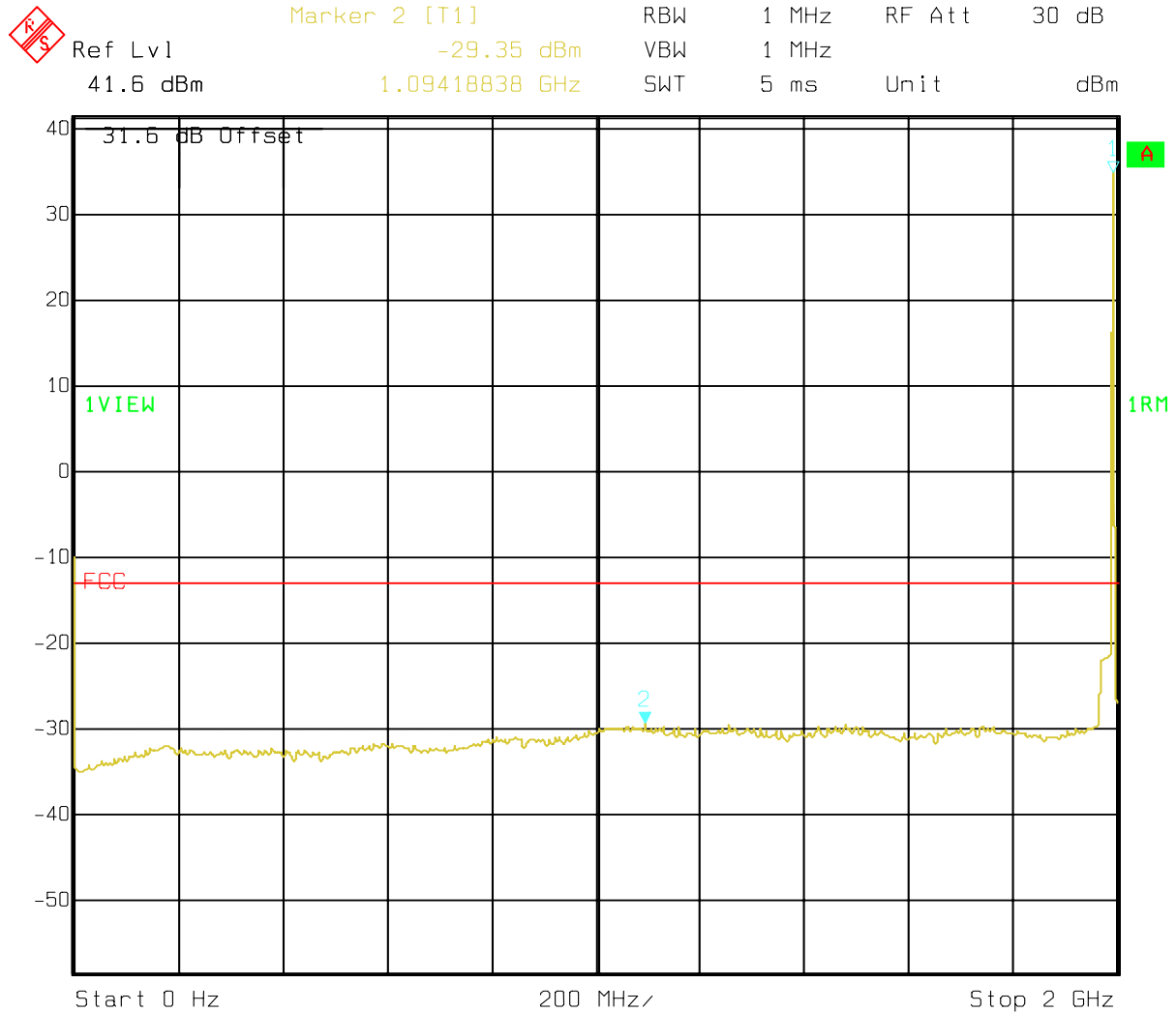

Title: SPURIOUS EMISSIONS AT ANTENNA PORT
Comment A: FCC ID: AB6NT1900SFRM. CDMA 1900 SFRM CHANNEL 1175
Date: 30.NOV.2001 14:46:52

Figure 21 : Conducted Spurious Emissions - DPM, Channel 1175 (7 GHz - 20 GHz)

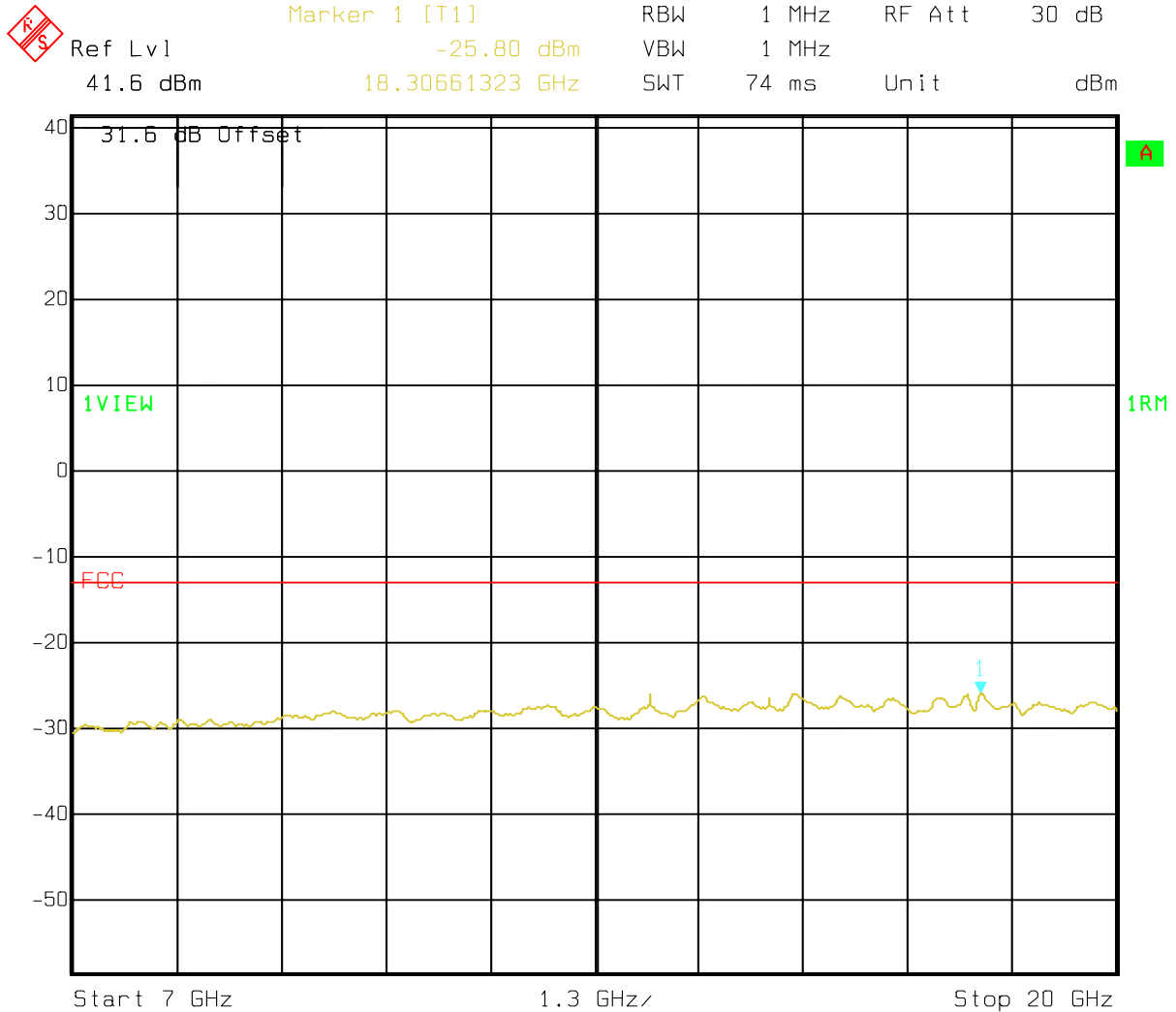

Title: SPURIOUS EMISSIONS AT ANTENNA PORT
 Comment A: FCC ID: AB6NT1900SFRM. CDMA 1900 SFRM CHANNEL 1175
 Date: 30.NOV.2001 14:47:45

4.4 Frequency Stability

4.4.1 Frequency Stability Requirements

FCC Part 2.1055

(a) The frequency stability shall be measured with variation of ambient temperature as follows:

(1) From -30 to +50 centigrade for all equipment except that specified in subparagraphs (2) and (3) of this paragraph.

(b) Frequency measurements shall be made at the extremes of the specified temperature range and at intervals of not more than 10 centigrade through the range. A period of time sufficient to stabilize all of the components of the oscillator circuit at each temperature level shall be allowed prior to frequency measurement. The short term transient effects on the frequency of the transmitter due to keying (except for broadcast transmitters) and any heating element cycling normally occurring at each ambient temperature level also shall be shown. Only the portion or portions of the transmitter containing the frequency determining and stabilizing circuitry need be subjected to the temperature variation test.

(d) The frequency stability shall be measured with variation of primary supply voltage as follows:

(1) Vary primary supply voltage from 85 to 115 percent of the nominal value for other than hand carried battery equipment.

(2) For hand carried, battery powered equipment, reduce primary supply voltage to the battery operating end point which shall be specified by the manufacturer.

(3) The supply voltage shall be measured at the input to the cable normally provided with the equipment, or at the power supply terminals if cables are not normally provided. Effects on frequency of transmitter keying (except for broadcast transmitters) and any heating element cycling at the nominal supply voltage and at each extreme also shall be shown.

(e) When deemed necessary, the Commission may require tests of frequency stability under conditions in addition to those specifically set out in paragraphs (a), (b), (c) and (d) of this section. (For example, measurements showing the effect of proximity to large metal objects, or of various types of antennas, may be required for portable equipment.)

FCC Part 24.235 Limit

The frequency stability shall be sufficient to ensure that the fundamental emission stays within the authorized frequency block.

4.4.2 Results

The DE incorporates a GPS module from Trimble Navigation. This 10MHz GPS reference is used to synchronize the entire Base Station. The GPS module has a frequency stability of 0.8 ppb over the range of -5C to 70C. The Base Station complied with the requirement.

References

- [1] FCC Part 24 Subpart E, “Personal Communication Services”, http://www.access.gpo.gov/nara/cfr/waisidx_00/47cfr24_00.html
- [2] FCC Part 2 Subpart J, “Frequency allocations and radio treaty matters; general rules and regulations”, http://www.access.gpo.gov/nara/cfr/waisidx_00/47cfr2_00.html
- [3] TIA/EIA-97-D “Recommended Minimum Performance Standards for Base Stations Supporting Dual Mode Spread Spectrum Systems”, June 2001

END OF DOCUMENT