

Exhibit E

User Documentation

Proprietary

CDMA MCBTS 1900 Cell Site Requirements

Issue 0.01

Document: CDMA MCBTS 1900 Cell Site Requirements

June 18, 1998

NORTEL Wireless Networks
CDMA BTS Radio Development
BTS Radio Systems 2M41

Security Warning:

The information contained in this document is the property of Northern Telecom Ltd. The holder of this document shall keep all information contained herein confidential and shall protect the same in whole or in part from disclosure and dissemination to all third parties.

FCC ID:AB6MCBTS1900B

NORTEL
NORTHERN TELECOM

1.0 EXECUTIVE SUMMARY	1
2.0 INTRODUCTION	2
3.0 ENVIRONMENTAL REQUIREMENTS	3
4.0 MECHANICAL REQUIREMENTS	4
4.1 Physical Specifications	4
4.1.1 Digital Enclosure	4
4.2 RFM	6
4.3 General Cabinet Anchoring	7
4.4 Pad Mounting	7
4.5 Rubber Isolation Pad	7
4.6 Cable Ingress/Egress	7
5.0 AC POWER REQUIREMENTS	8
5.1 Power Specifications	8
5.2 AC Connection	8
6.0 RF OVERLAY REQUIREMENTS	9
6.1 Cable connections	9
7.0 GPS RECEIVER	14
8.0 CONNECTIONS AND CABLING	15
8.1 RFM Power Connections and Cables	15
8.2 RFM Interconnect	15
8.3 Fiber	18
9.0 T1/E1 CONNECTIONS	20
10.0 GROUNDING	21
10.1 BTS Grounding Architecture	21
10.2 Antenna Grounding	21
10.3 RFM Grounding	21
10.4 Site Ground Ring	21

DRAFT

DRAFT

1.0 EXECUTIVE SUMMARY

The CDMA MCBTS 1900 Outdoor BTS is a new product development for Nortel's PCS markets in North America. This document details cell site requirements for the full MCBTS Outdoor product.

DRAFT

2.0 INTRODUCTION

This document outlines the cell site engineering requirements for the CDMA MCBTS 1900 Outdoor System. Its intended audience is the cell site engineering team who will use this information on the capabilities of the MCBTS to plan the installation of the product at a cell site. The cell site engineering team should have expertise in mechanical, grounding, power, telecom, and RF engineering.

Specifications in the Product Specification Agreement (PSA) shall take precedence over information in this document.

The MCBTS cell site requirements fall into six main categories:

- mechanical requirements
- grounding requirements
- power requirements
- signal interface requirements
- antenna requirements
- carrier requirements

The mechanical requirements cover the physical characteristics (weight, size), the mounting requirements and restrictions, and the shipping, hoisting, and lifting requirements of the Digital Enclosure and the Radio Frequency Modules (RFM).

The MCBTS will be deployed in a number of environments potentially both indoors and outdoors. This document covers the MCBTS outdoor version.

3.0 ENVIRONMENTAL REQUIREMENTS

The external environmental operating condition requirements are described in this section. Table 1: lists the MCBTS thermal ratings.

Thermal Rating	Range
Operating Range (Normal Operation - 24 hours per day)	-40° C to +50° C (41° F to 105° F)
Operating Range (Short Term Operation - Not more than 72 hours continuous or 15 days per year)	-55° C to +65° C (32° C to 120° C)
Non-operating Range (Storage) for 72 hours	-50°C to +70°C (-60°F to 160°F)

Table 1: MCBTS Thermal Rating

The altitude specifications are listed in Table 2:

Operational State	Range (m)
Standard Operation (Normal Operation - 24 hours per day)	1800
Non-Operating Range (Storage)	-60 to 15000

Table 2: MCBTS Altitude Rating

The relative humidity specifications are listed in Table 3:

Relative Humidity	Range
Operating Range (Normal Operation - 24 Hours Per Day)	5 to 95% (Non-Condensing)
Non-Operating Range (Storage for 96 hours)	90-95% RH at 40°C

Table 3: MCBTS Humidity Rating

4.0 MECHANICAL REQUIREMENTS

4.1 Physical Specifications

The MCBTS is comprised of a digital enclosure (DE) and radio frequency modules (RFM). The digital enclosure is designed to be mounted on the ground while the RFM's are designed to be remote mounted.

4.2 Digital Enclosure

The DE is the main structural component in the MCBTS. The digital enclosure will house the rectifiers, equipment shelves, internal heating/cooling tray, heat exchanger internal loop fan assembly and provide for all necessary internal cable routing/management.

The preliminary outside dimensions for the DE are illustrated below. These dimensions refer to the unpackaged height and are excluding the DEI which attaches to the left side and the heat exchanger which mounts on the top.

The dimensions are:

- Depth: 30"
- Height: 57" Max (excluding 15" high heat exchanger)
- Width: 30"

The DE with no shelves will weigh an estimated 190 lbs.

4.3 Digital Enclosure Interface

The Digital Enclosure Interface (DEI) for the MCBTS enclosure assembly provides entrance of AC power, network and alarm connections, and connection to the ground ring. The dimensions of the DEI are shown below.

The dimensions are:

- Depth: 30" (same as overall depth of Digital Enclosure)
- Height: 72"
- Width: 12"

The weight of the empty DEI is estimated to be 225 lbs. The loaded module weight after integration of equipment is expected to be 700 lbs.

Cable access to the DE is via the DE interface (DEI)

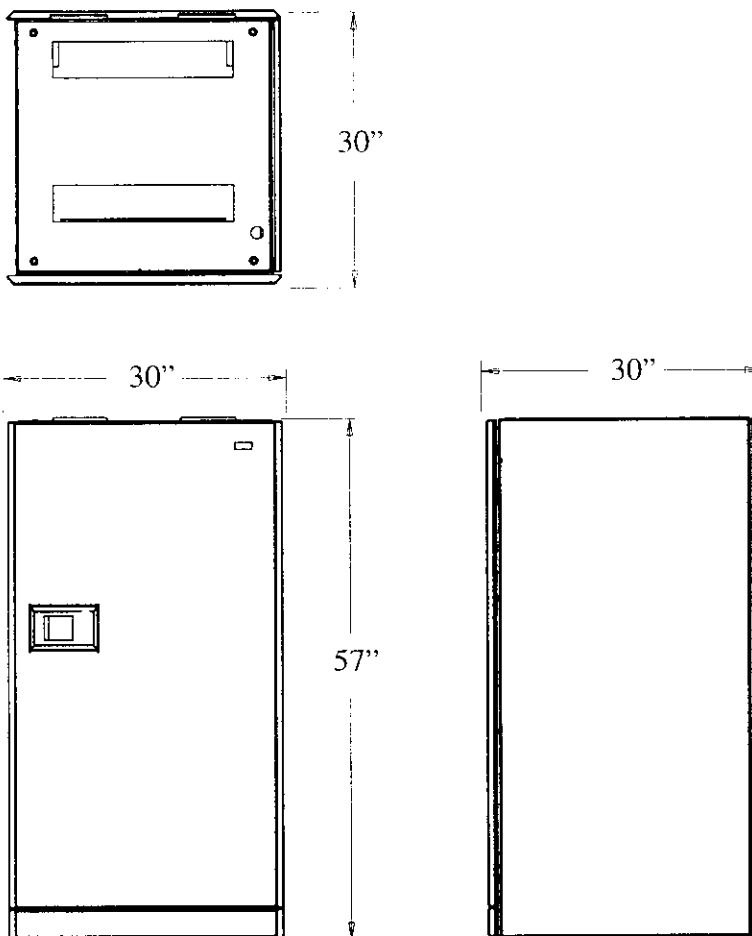

4.4 External Battery Cabinet

The MCBTS external battery cabinet (EBC) is an optional stand alone enclosure that provides additional battery backup to the digital enclosure. It will be located adjacent to the DE at the installation site and allow for one additional EBC to be daisy chained together to provide additional battery backup.

The EBC utilizes the DE as its external enclosure for environmental protection. Four lifting eyes are provided at the top of the EBC for installation at the cell site.

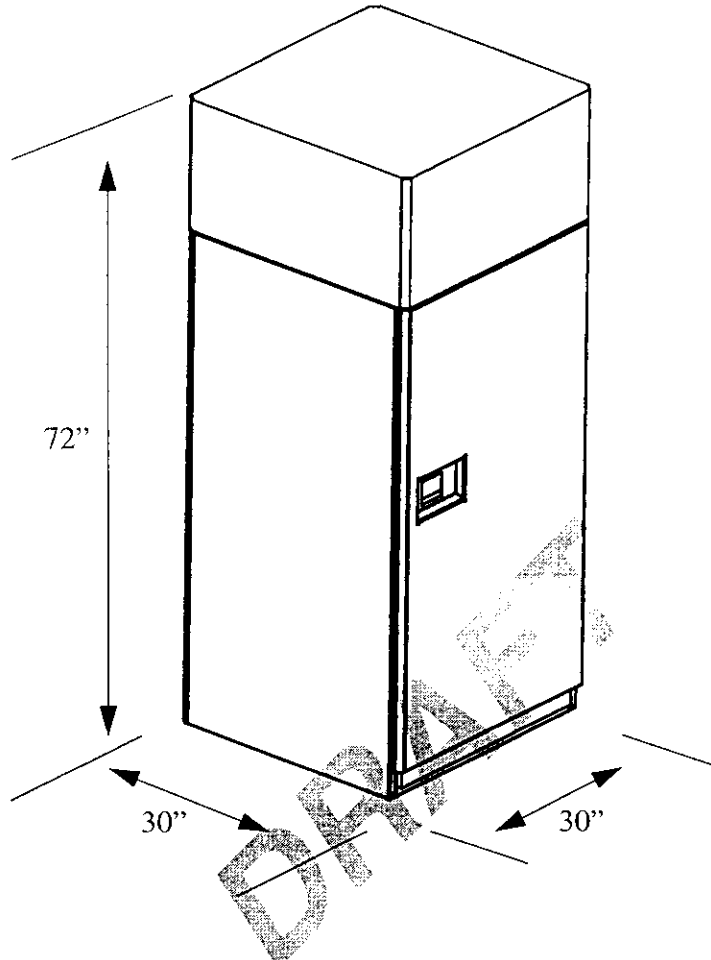

ISOMETRIC VIEW

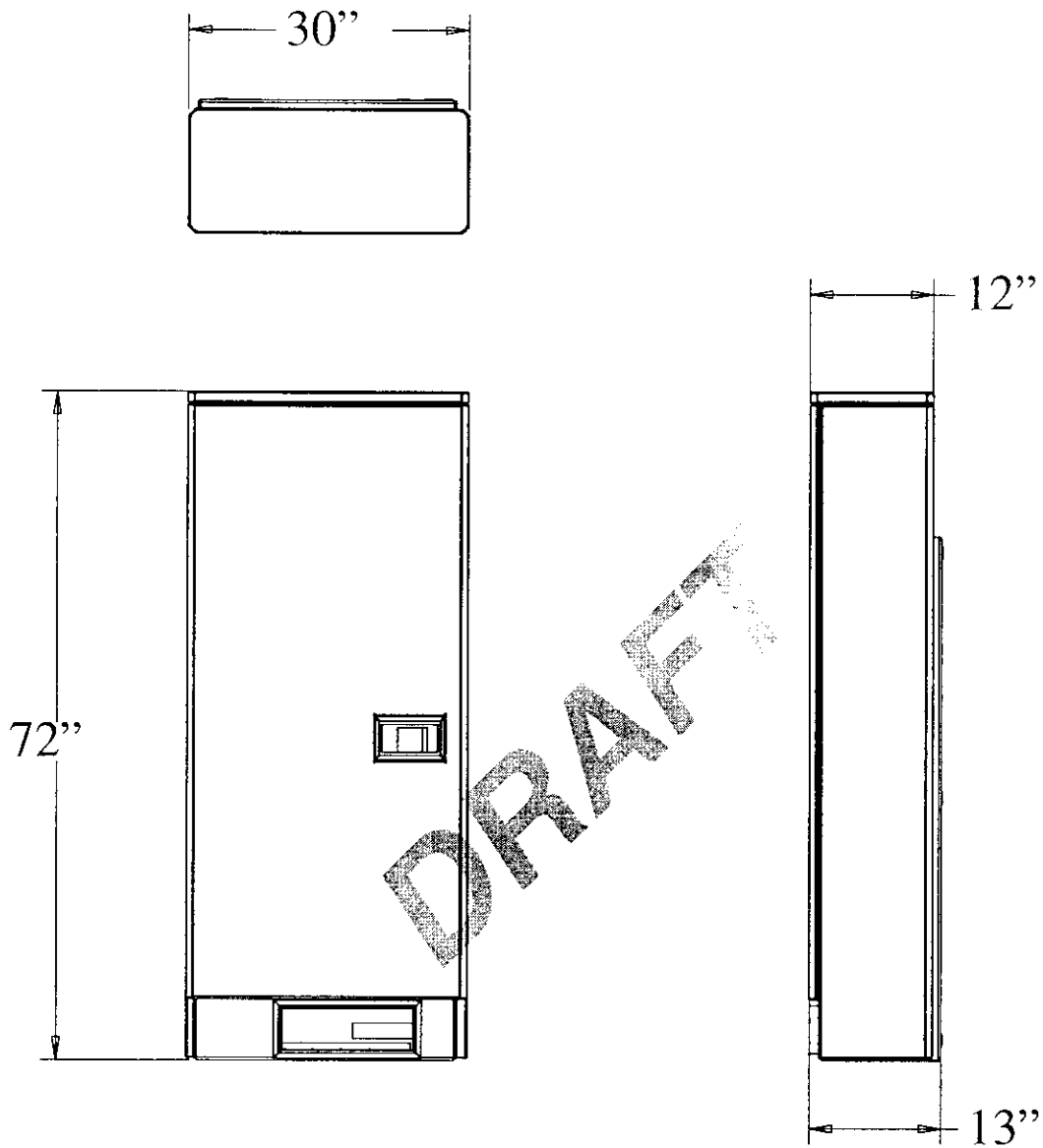

4.4.1 RFM

The preliminary outside dimensions for the RFM are shown below. These dimensions refer to the unpackaged height and are excluding the EOM which attaches to the bottom of the RFM on the right hand side.

The dimensions are:

- Depth: 12.1”
- Height: 27.92”
- Width: 34.1”

The complete RFM will weight an estimated 120 lbs.

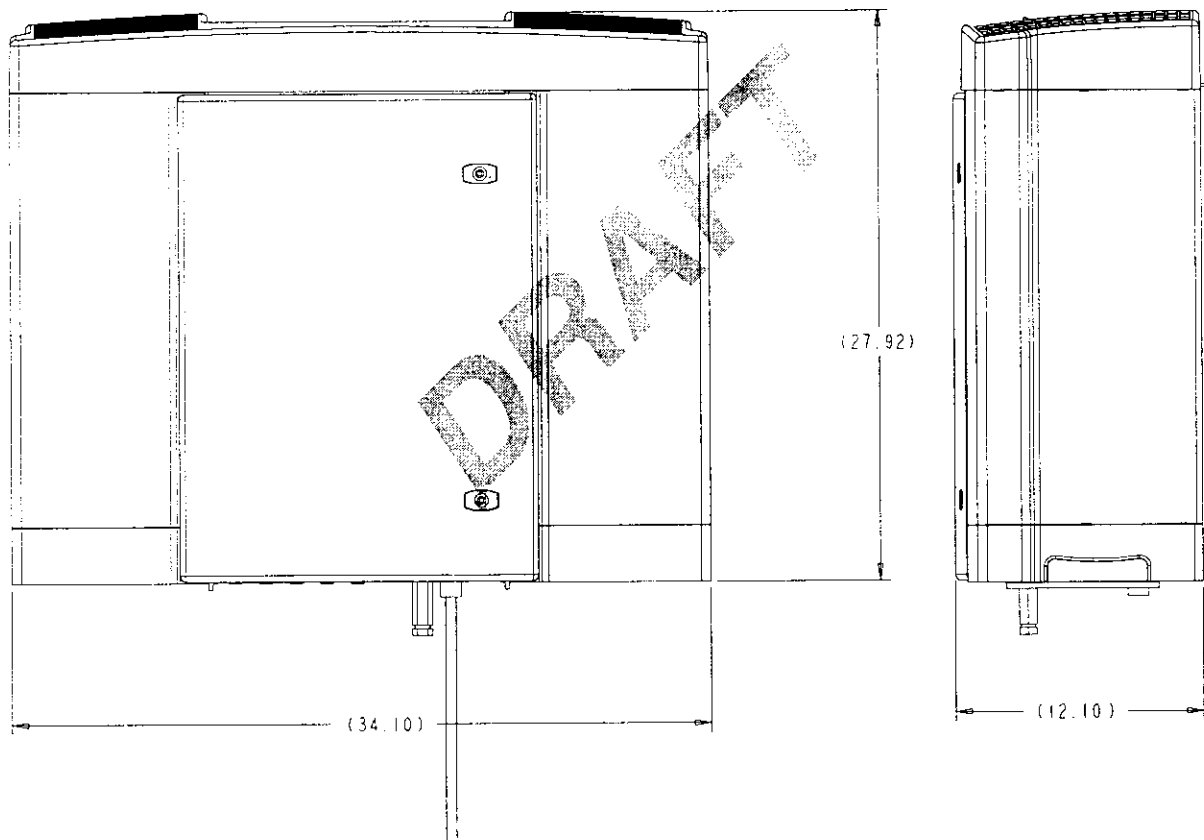

RFM Mounting (preliminary)

The RFM is intended to be installed onto standard Unistrut type C-channel mounting hardware. There is a mounting bracket that will be pre-installed onto the uni-strut. This

will provide mounting, locating and hanging features that will allow the RFM to be installed and hang in place until it can be fastened. The mounting plate serves as a demarcation point for the interconnect.

4.5 General Cabinet Anchoring

The DE is designed to be hoisted by a crane. Four mounting points are provided on the top of the cabinet for hoisting.

4.6 Pad Mounting

The MCBTS shall be mounted on a concrete slab.

4.7 Rubber Isolation Pad

The DE shall be mounted on a rubber pad.

4.8 Cable Ingress/Egress

Cable access to the RFM is

DRAFT

5.0 AC POWER REQUIREMENTS

5.1 Power Specifications

Commercial ac power will be supplied to the DE as a single/split-phase, 120/240 Vac (nominal, or 120/208 Vac two phase), four conductor (L1, L2, Neutral and Ground), connection from an external service entrance. The ac power input specifications are as follows:

- Nominal Input Voltage: 240/120 Vac, single, split phase, 60 Hz
- Input Voltage Range: 178 to 264 Vac (or 105 to 132 Vac line to neutral)
- Input Frequency: 47 - 63 Hz
- Power Factor: greater than 90% at nominal line voltage and frequency.
- Input Current Rating: 70A, 2-pole circuit breaker.

5.2 AC Connection

All external power enters the system via the DEI. A four wire (L1, L2, Neutral, and ground), nominal 240/120V (or 208/120V), 100A rating, ac supply must be supplied by the customer. Primary power is by connection to the ac utility. If the DEI is to be the service entrance, the neutral-ground jumper in the ac panel should be connected. Otherwise, it should be removed. Auxiliary power access is via the external ac generator receptacle connector.

Signal Interface	quantity	wire rating/gauge	Connector Description
AC utility	1 (3-C + gnd)	70A Bkr, AWG #4, 90 0C	Refer to ...
Generator Socket	1 (3 -C + gnd)	70 A Bkr, AWG #4, 90 0C	Refer to ...

Table 4: AC Utility Connections

6.0 RF OVERLAY REQUIREMENTS

The MCBTS has several overlay options.

Basic installation configuration (single channel)

Simple overlay on mini configuration

The minimum requirement (1 carrier) is 2 antennas per sector. One for the main antenna (Tx and one diversity path) and one for the other diversity path. A two carrier system can also be supported with two antennas. In this case, each antenna carries one carrier on the Tx side and one diversity path on the Rx side. With a three carrier system a third antenna is added to carry just the Tx of the third carrier.

Number of Carriers	Number of Antennas per Sector
1	2
2	2
3	3

Table 5: System Antenna Provisioning

6.1 Cable connections

The optical link cable, SRFM DC power cable, and the GPS antenna cable have a provisionable length. When ordering, the length must be specified and fall below the maximum length specifications indicated.

The quantity of inter-SRFM cables required depends upon the application. In a single carrier system, no inter-SRFM cables are required. In 2 or 3 carrier systems, inter-SRFM cables are required.

Two sample configurations will be considered for illustrative purposes. These are

- i) a basic system with no redundancy and
- ii) a premium system with all redundancy.

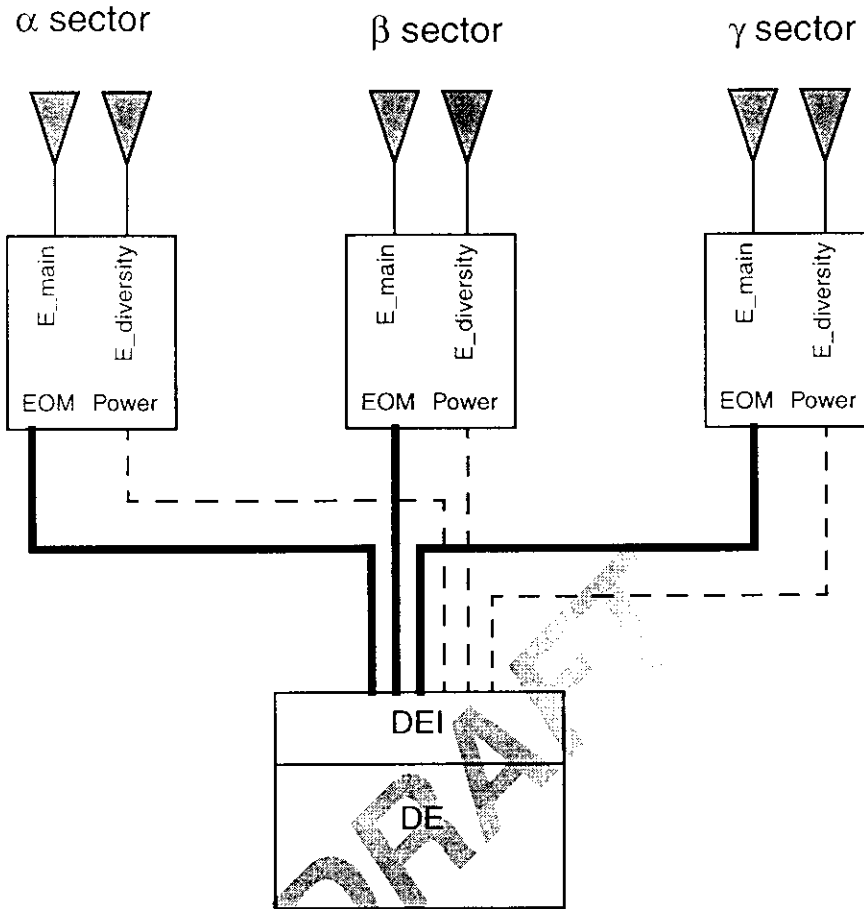

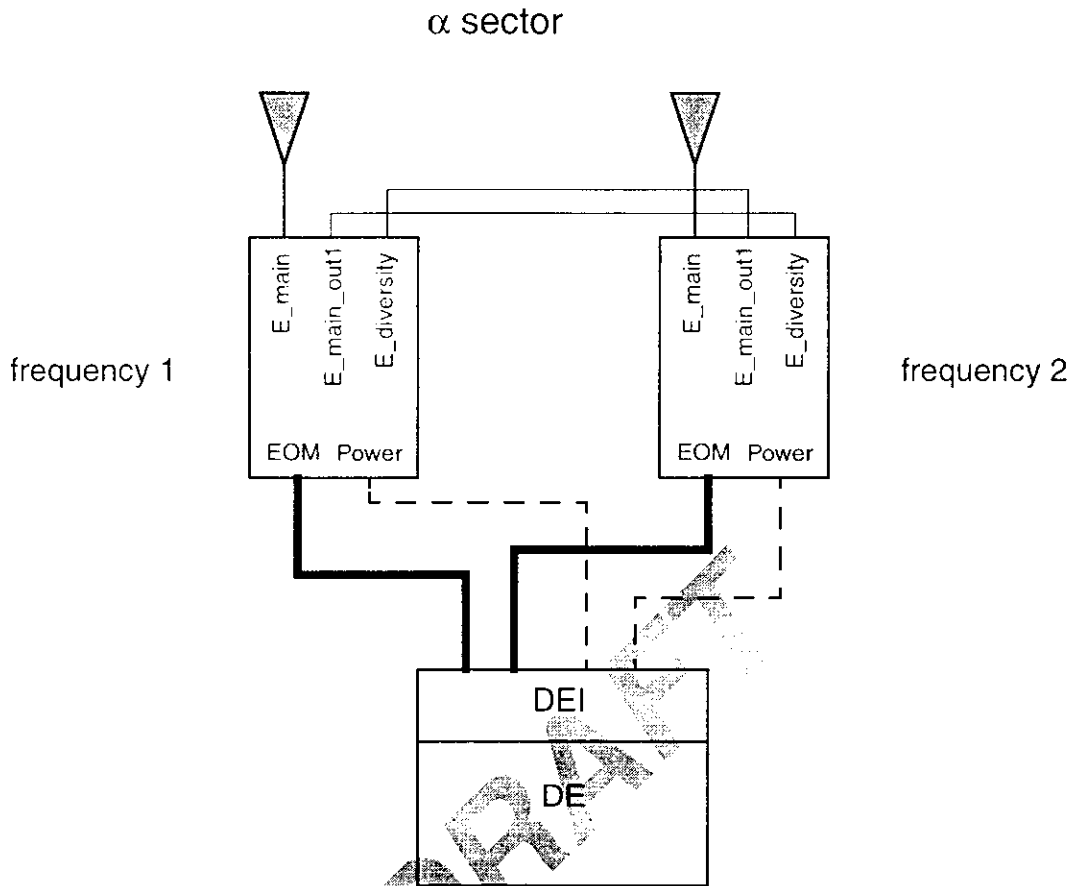

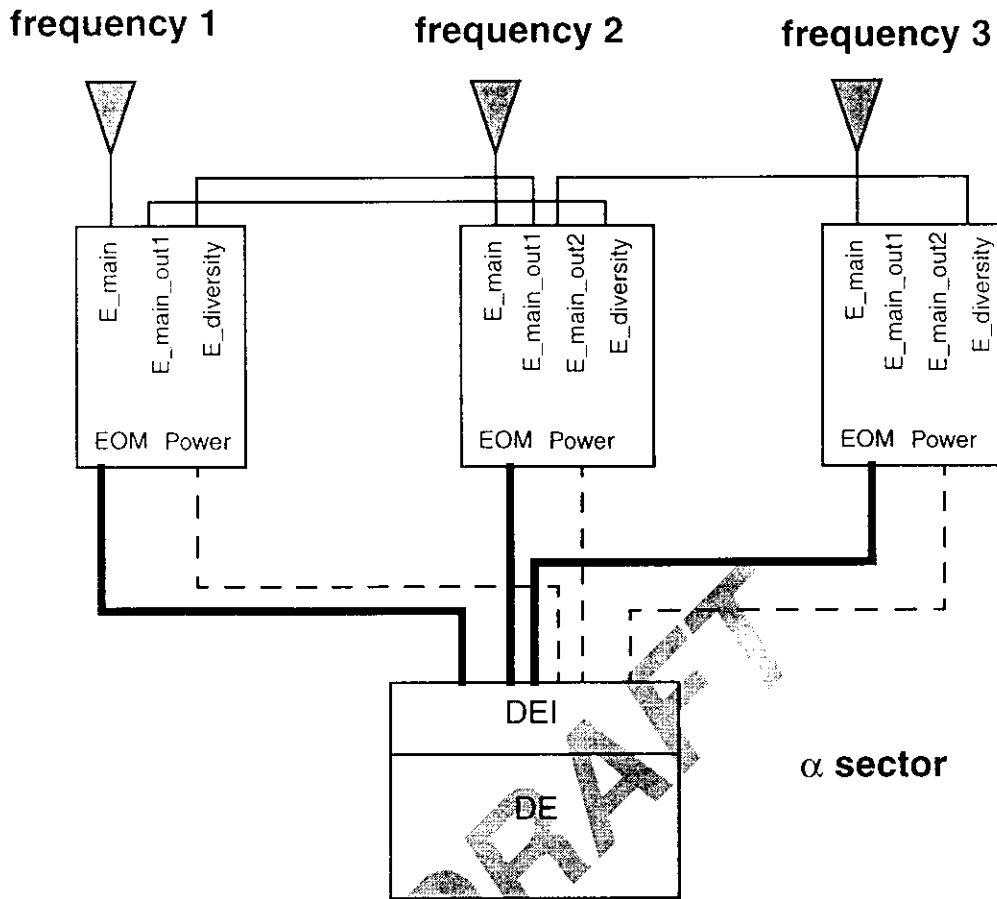

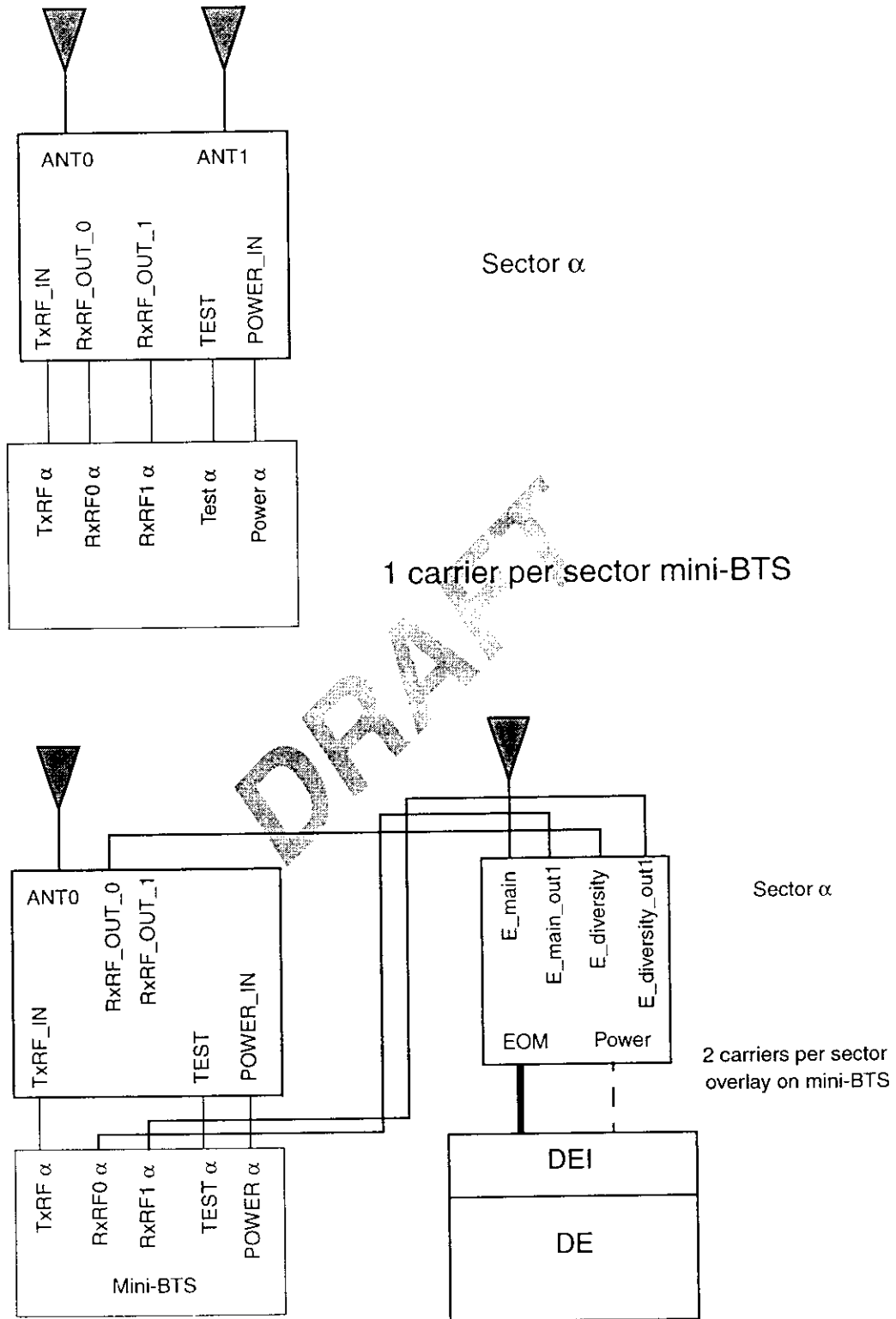

7.0 GPS RECEIVER

Timing and frequency reference information provided by the GPS receiver is critical to the proper operation of the MCBTS subsystem. One or two GPS antennas may be connected. The GPS antenna receives the signals from multiple satellites, and the signal is supplied to the GPS receiver in the MCBTS via a coaxial cable. Precautions should be taken to ensure that the GPS antenna is clear of obstructions and interference.

The antenna should be installed to provide the best view of the entire sky. A complete view of the sky from horizon to horizon will enable the receiver to observe as many GPS satellites as possible. This allows the GPS receiver to select the best combination of GPS satellites for best performance. If the GPS antenna must be installed with a limited view of the sky, it may not be able to track a sufficient number of satellites to determine its position. The GPSR must track at least 4 satellites simultaneously for some period of time in survey mode. Once the GPSR has an accurate fix on its location, it can maintain accurate timing signals to the BTS while tracking only 1 satellite.

The maximum distance between the MCBTS and the GPS antenna is set by the maximum allowable cable loss of ?? dB. The cable length and type is required by the GPS receiver for determining the delay from the antenna to the receiver.

			Cable Connector Type	
Max Loss	Max Length	Cable Type	On MCBTS end	On Antenna end
?? dB	?? ft	??	N-type male	TNC- type male

Table 6: GPS Antenna Interface

8.0 CONNECTIONS AND CABLING

8.1 RFM Power Connections and Cables

DC power is conducted to individual RFM's via two conductor (-48V, BR) shielded (ground) cables; one cable for each RFM. The size of the power cable used depends on the cable run length. The DC power cable from the DEI enters the RFM enclosure via the Power Entry Module (PEM).

The specifications for these external RFM dc cables are as follows:

- Less than 3000 feet, use 2 conductor #8 AWG shielded cable
- Between 300 and 600 feet, use 2 conductor #6
- Allowed Cable Voltage Drop: 6 Vdc maximum (-48V and Rtn combined)
- Cable Terminations: two-hole lugs at the DEI BRR plate, twist-lock type connector at RFM (to mate with the PEM)
- Shield Termination: grounded at both the RFM and DEI ends, and at the base of the tower.

The RFM DC cable is sized for voltage drop, not ampacity.

The optical link enters the RFM via the electro-optic module (EOM).

8.2 RFM Interconnect

Table 14 below shown the RFM external interconnect single carrier configuration. Table 15 shows the RFM external interconnect multi carrier configuration.

Name	Type	Format	# Pins	From	To	Note
Direct Connection to the RFM from the Digital Enclosure.						
E_pwr ^a /ret	48 VDC	DC	2	DEI	RFM	Supplies primary DC power to the RFM.
E_gnd	GND	GND	1	DEI	RFM	
E_shield	GND	GND	1	DEI	RFM	
Electro-Optical Module (EOM)						
E_rfm_rvs1	629.145 Mbs	optical	1	EOM	CORE1	Primary or Redundant digital link to Digital Enclosure
E_rfm_fwd1	629.145 Mbs	optical	1	CORE1	EOM	
E_rfm_rvs2	629.145 Mbs	optical	1	EOM	CORE2	Primary or Redundant digital link to Digital Enclosure
E_rfm_fwd2	629.145 Mbs	optical	1	CORE2	EOM	
Misc.						
gnd	GND	#6 AWG	1	RFM	RFM Mounting Plate	connect to RFM chassis (cold plate)

Table 7 RFM Interconnect

a. E_ in the name designates a connection external to the RFM Assembly.

The next table shows the interconnect for the multicarrier configuration. Table of RFM Assembly Interconnect (multiple carrier per sector)

Name	Type	Format	# Pins	From	To	Note
Direct Connection to the RFM from the Digital Enclosure.						
E_pwr ^a /ret	48 VDC	DC	2	DEI	RFM	Supplies primary DC power to the RFM.
E_gnd	GND	GND	1	DEI	RFM	
E_shield	GND	GND	1	DEI	RFM	
Electro-Optical Module (EOM)						
E_rfm_rvs1	629.145 Mbs	optical	1	EOM	CORE1	Primary or Redundant digital link to Digital Enclosure
E_rfm_fwd1	629.145 Mbs	optical	1	CORE1	EOM	
E_rfm_rvs2	629.145 Mbs	optical	1	EOM	CORE2	Primary or Redundant digital link to Digital Enclosure
E_rfm_fwd2	629.145 Mbs	optical	1	CORE2	EOM	
RF Lightning Protector Array (LPA)						
E_main	1930-1990 MHz and 1850-1910 MHz	N-type coax	1	LPA	Tx/Rx Main Antenna	
E_diversity	1850-1910 MHz	N-type coax	1	LPA	Other RFM/RFFE	
diversity	1850-1910 MHz	N-type coax	1	RFM	LPA	
E_main_out1	1850-1910 MHz	N-type coax	1	LPA	Other RFM Assembly	Only used with multiple RF-MAs per Sector
main_out1	1850-1910 MHz	N-type coax	1	RFM	LPA	
E_main_out2	1850-1910 MHz	N-type coax	1	LPA	Other RFM Assembly	
main_out2	1850-1910 MHz	N-type coax	1	RFM	LPA	
E_diversity_out	1850-1910 MHz	N-type coax	1	LPA	Mini-BTS	Only used when deployed with a Mini-BTS Overlay
diversity_out	1850-1910 MHz	N-type coax	1	RFM	LPA	
gnd	GND	#6 AWG	1	LPA	RFM	connect to RFM chassis (cold plate)
E_gnd	GND	#2 AWG	1	LPA	Tower	connect to tower or local site ground
Misc.						
gnd	GND	#6 AWG	1	RFM	RFM Mounting Plate	connect to RFM chassis (cold plate)

Table 8 RFM Interconnect

a. E_ in the name designates a connection external to the RFM Assembly.

MHU Assembly

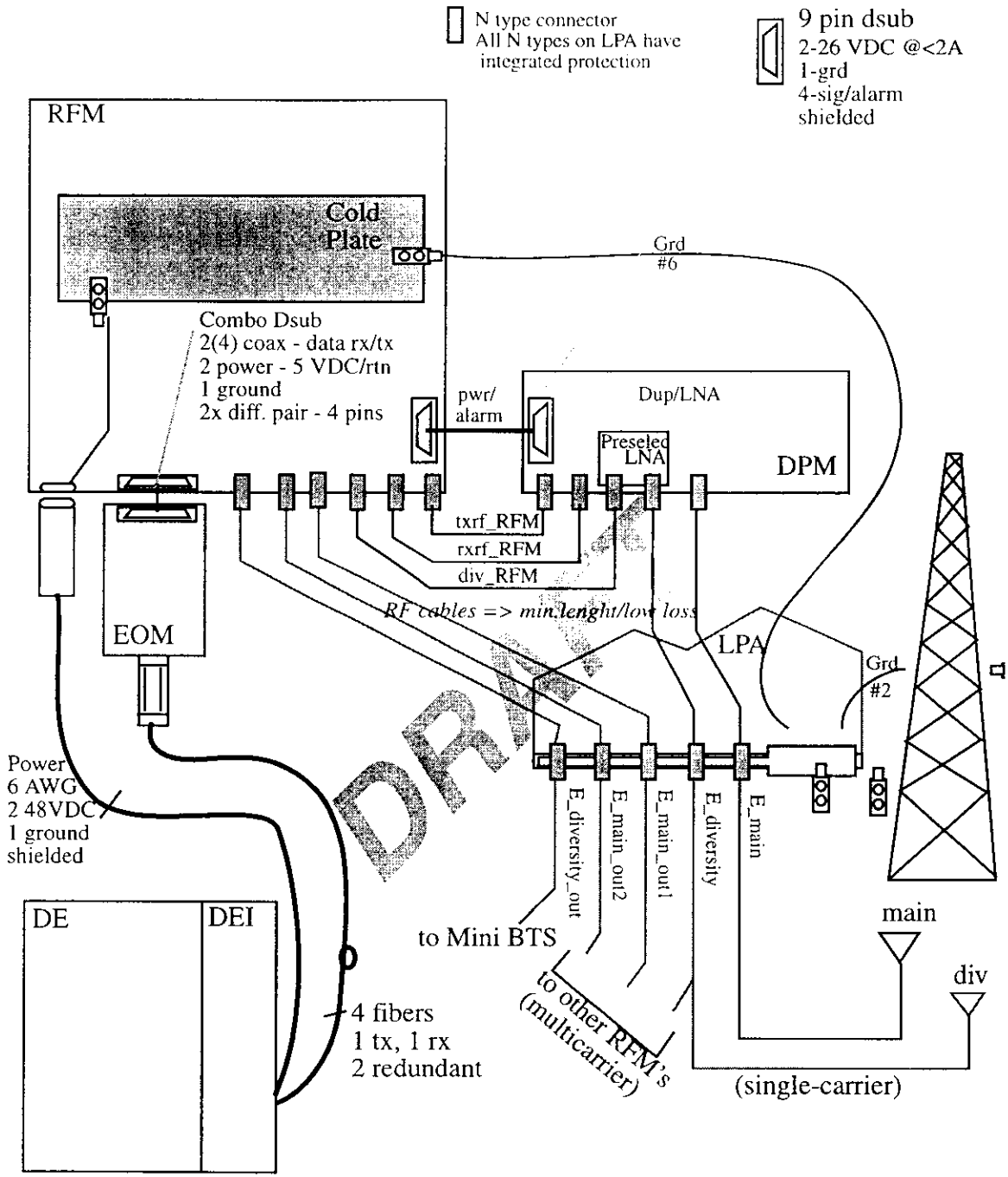

Figure 1 RFMA Interconnect

Optical Link Interconnect Design Details.

The optical link encompasses the physical parts from CORE transceiver to RFM transceiver. This includes transceivers, fibers, connectors, splice points, and fiber management. Figure 17 below shows the potential layout. The reference for the information on the optical link is taken from "MCBTS Optical Link General Specification"; TL-0M00-20-97, Issue 1.0.

8.3 RFM Optical Link Interconnect

The baseline design has the following configuration.

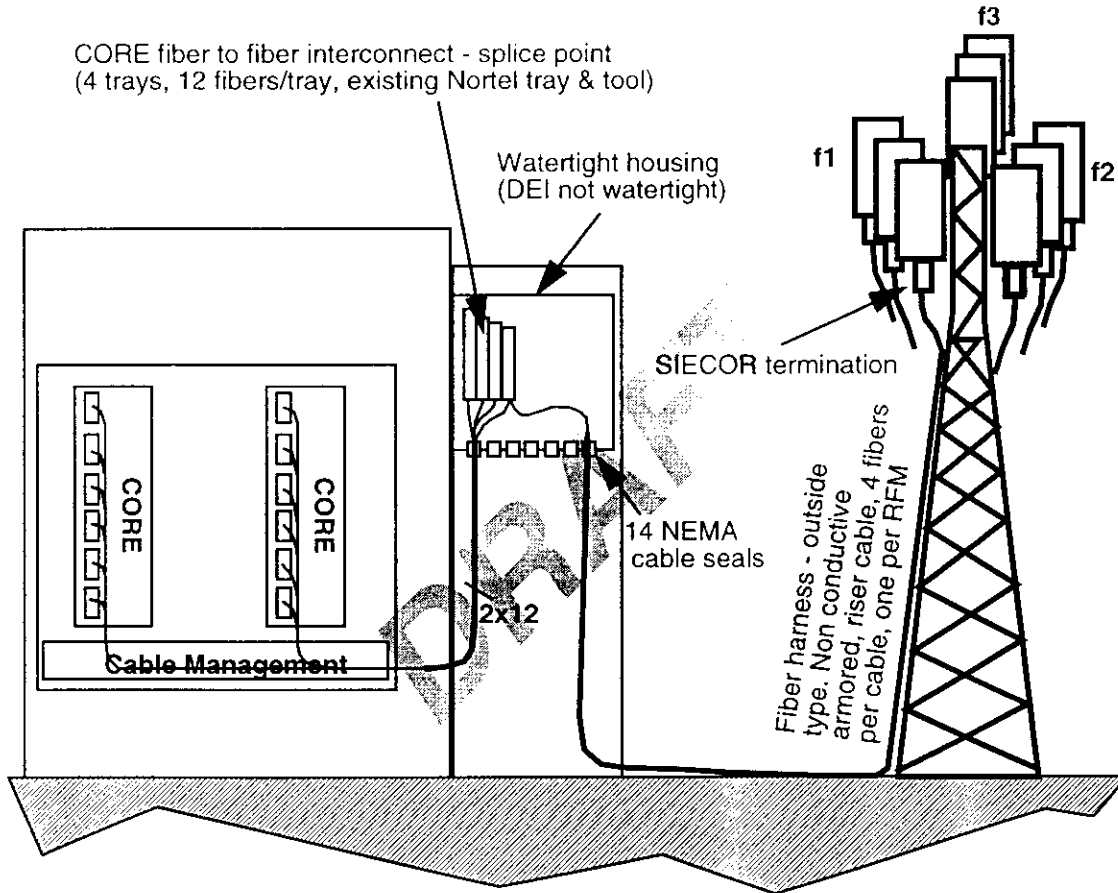

Figure 2 RFM Optical Link Baseline Design

8.4 Fiber

The optical link to the RFM will contain 4 fibers per link. Two receive and transmit pairs for redundancy, unless multicarrier deployment is used, when soft redundancy is handled by the other carrier and only two fibers are used (other two left unused). The main portion of the link will run on outside plant cable capable of vertical ascent, terminated at the

RFM by an standard SIECOR optifit termination. The transceivers will be housed in a heated optical termination unit which is connected to the RFM by electrical interconnect. The high speed signals will be carried by 4 coaxial links.

Fiber interconnect and rearrangement features are required to interconnect the RFM's to the Digital enclosure. Current baseline design has the digital enclosure provisioned with a optical link harness, fiber storage and management, as well as a flexibility point (splice point) in the DEI cabinet capable of handling all 48 fibers in the fully configured case. The flexibility point need not be fully configured for the single carrier application, and splice trays specified are off the shelf from multiple vendors.

The RFM will have an EOM unit which depends upon the length of the fibre run from the DE to the RFM.

DRAFT

9.0 T1/E1 CONNECTIONS

The CM module has up to 6 T1 interfaces connected through the faceplate. The cable will probably be lumped in two 12 wire bundles terminated at the CM by two 15 pin dsubs.

The MCBTS may be configured with anywhere from 1 to 6 T1/E1 links. Each link requires 2 twisted pair. All the twisted pairs may be combined into a single cable along with the subscriber loop twisted pair. Customer interface will be through the DEI accessible T1 protection terminal block.

(Daisy chain configuration)

DRAFT

10.0 GROUNDING

10.1 BTS Grounding Architecture

The RFM is grounded to its mounting structure, whether a tower, wall, building or pole. If the structure is non-conductive (e.g. wooden pole) it shall be provided with a ground cable as part of the site ground.

The RFM mounting structure and BTS cabinets both connect to the site ground ring. #2 AWG cables less than ten feet long are used for these primary, external ground connections.

10.2 Antenna Grounding

Each GPS antenna will be grounded at the antenna mast and again at the cable entry point (coax cable shield) inside the DEI. Similarly the cell site antenna(s) are grounded at the tower and may be further protected by lightning rods on the mounting structure, protruding above the antennas, preventing direct strikes to them.

10.3 RFM Grounding

The shield of each coaxial cable connected to the RFM shall be bonded to the RFM chassis. Additionally, the RFM chassis shall be bonded to the external ground system (e.g. tower) using No. 2 AWG solid tinned copper conductor. Provision shall be made on the RFM cable bulkhead for termination of a No. 2 AWG, 2-hole lug connector.

The DC power cable connecting the main electronics cabinet to the RFM shall be grounded at both the RFM end and the main enclosure end (main ground plate).

10.4 Site Ground Ring

A peripheral grounding ring, usually buried around the site perimeter, or routed along the outer edge of the roof of a building, provides the main site ground. It provides an equipotential reference to minimize differential voltages during lightning surges. It provides an equipotential reference to minimize differential voltages during lightning surges. It consists of a #2 AWG (or larger) uninsulated, tinned copper conductor. Connections are made to it using C-tap clamps. All conductive surfaces or objects on the sites should be connected to it, especially the tower or other RFM mounting structure.

The ground ring makes earth contact through ground electrodes, typically copper-clad stakes 3m (10 ft) long, driven into the ground at 2.5 to 3m (8-10 ft) intervals around the ground ring and tower, and clamped to it. The resistance to earth of the ground ring shall be 25 ohms or less, with a preferred value of less than 5 ohms. See Nortel CS4122.00 and DSAP65BA (Cell Site Power and Grounding) for further information.

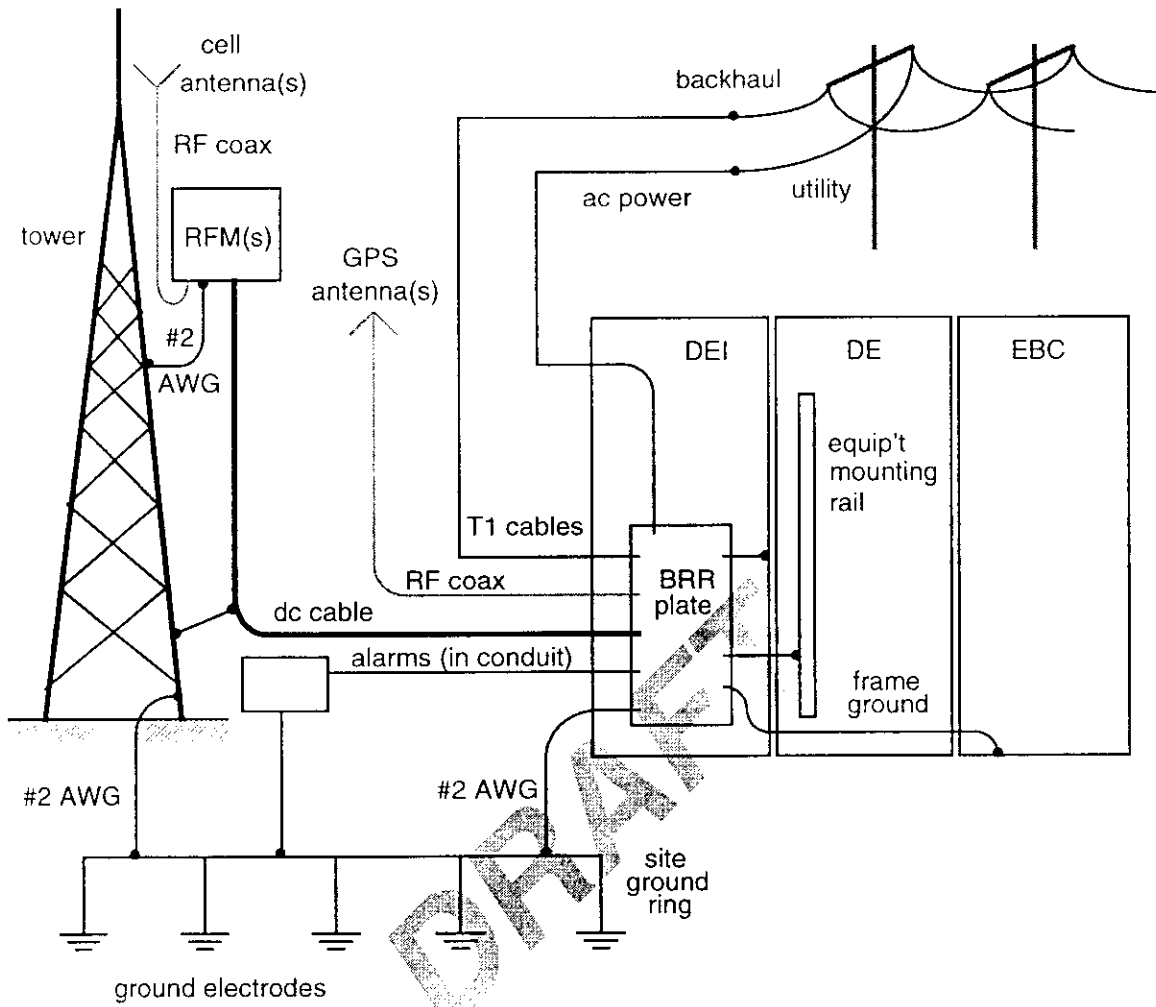

11.0 REFERENCES

- [1] CMS-MTX/CDMA MCBTS 1900 Outdoor and MCBTS Base Platform. Product Specification Agreement.
- [2] CDMA MCBTS 1900 Outdoor. Power Protection and Grounding Design Specification.
- [3] CDMA MCBTS 1900 Outdoor. General Specification.
- [4] MCBTS Optical Link NTGS05AA, NTGS0117, NTGS0095 Functional Agreement. Packaging Concepts Methodology.
- [5] MCBTS Digital Enclosure Mechanical Assembly NTGS13AA Functional Agreement. Packaging Concepts Methodology.
- [6]

DRAFT

Exhibit F

Photographs

List of Photographs

Photograph 1:RFM with Doors Closed

Photograph 2:RFM with Doors Open

Photograph 3:PAM

Photograph 4:TRM Component Side with Shield On

Photograph 5:TRM Solder Side with Shield On

Photograph 6:TRM Component Side with Shield Removed

Photograph 7:TRM Solder Side with Shield Removed

Photograph 8:DPM

Photograph 9:Microprocessor Card

Photograph 10:EOM with Shield Removed

