



EXHIBIT 2

Test Report

Applicant: Northern Telecom Ltd.

For Certification on:

AB6ECCELL

ECELL BTS GSM1900: FCC Part 24 Certification Filing for Nortel AB6ECELL : exhibits document

Reference : PCS/BTS/DJD/0751
Version : 01.01 / EN
Date : 10/03/02

Ext. ref. : AB6ECELL
Type : DQF
Product : ECELL
Cat : E
Status : A

Author : A. CAILLE

Documentalist : A.M. LE BERRE

Approved by : R. JACQUES

Quality representative :

Abstract / Comments :

Document PCS/BTS/DJD/0751 present the FCC Certification filing realized in order to introduce the ECELL BTS GSM1900 systems

Distribution lists :

DOCUMENT AMENDMENTS

VERSION	DATE	COMMENTS	AUTHOR
01.01	10/03/02	Document creation	A. CAILLE

*This confidential document is the property of NORTEL MATRA CELLULAR and may not be copied or circulated without permission
Ce document confidentiel est la propriété de NORTEL MATRA CELLULAR et ne peut être reproduit ou communiqué sans autorisation*

PCS

NORTEL
NORTHERN TELECOM

Reference : PCS/BTS/DJD/0751
Version : 01.01 / EN
Date : 10/03/02

**ECELL BTS GSM1900: FCC Part 24 Certification Filing for
Nortel AB6ECELL : exhibits document**

TABLE OF CONTENTS

1. INTRODUCTION.....	4
1.1. OBJECT.....	4
1.2. SCOPE.....	4
2. RELATED DOCUMENTS.....	4
2.1. APPLICABLE DOCUMENTS	4
2.2. REFERENCE DOCUMENTS	4
3. ABBREVIATIONS & DEFINITIONS.....	5
3.1. ABBREVIATIONS	5
3.2. FREQUENCY DEFINITIONS	5
4. EXHIBIT 1 : TEST REPORT	6
4.1. INTRODUCTION	6
4.2. MEASUREMENT RESULTS	6
4.3. NAME OF TEST : 2.1046 RF POWER OUTPUT	7
4.3.1. FCC REQUIREMENTS.....	7
4.3.1.1. FCC Part 24.232	7
4.3.2. TEST RESULTS	8
4.3.3. TEST PROCEDURE	9
4.4. NAME OF TEST : 2.1049 OCCUPIED BANDWIDTH	10
4.4.1. FCC REQUIREMENTS.....	10
4.4.1.1. FCC Part 2.1049	10
4.4.2. TEST RESULTS	10
4.4.3. TEST PROCEDURE	12
4.5. NAME OF TEST : 2.1051 SPURIOUS EMISSIONS AT ANTENNA TERMINALS.....	13
4.5.1. FCC REQUIREMENTS.....	13
4.5.1.1. FCC Part 24.238	13
4.5.2. TEST RESULTS	13
4.5.3. TEST PROCEDURE	29

*This confidential document is the property of NORTEL MATRA CELLULAR and may not be copied or circulated without permission
Ce document confidentiel est la propriété de NORTEL MATRA CELLULAR et ne peut être reproduit ou communiqué sans autorisation*

4.6.	NAME OF TEST : 2.1055 FREQUENCY STABILITY	31
4.6.1.	FCC REQUIREMENTS	31
4.6.1.1.	FCC Part 24.235	31
4.6.2.	TEST RESULTS	31
4.6.3.	TEST PROCEDURE	32
4.7.	NAME OF TEST : 2. 1053 FIELD STRENGHT OF SPURIOUS RADIATION ...	33
4.7.1.	FCC REQUIREMENTS	33
4.7.1.1.	FCC Part 24.238	33
4.7.1.2.	FCC Part 2.1053	33
4.7.2.	TEST RESULTS	33
4.7.3.	TEST PROCEDURE	34
4.8.	MEASUREMENT EQUIPMENT LIST	35
5.	EXHIBIT 2 : UPDATED EQUIPMENT LIST	36
6.	EXHIBIT 3 : SCHEMATICS	37
6.1.	ECELL ASSEMBLY	37
6.2.	PRDRX (RADIO BOARD)	37
6.3.	PLDRX (LOGIC BOARD)	37
6.4.	LPA HYBRID COUPLER ASSEMBLY	37
6.5.	LNA DIPLEXER ASSEMBLY	37
6.6.	PPCM BOARD	37
6.7.	PPCM BOARD	37
∞	END OF DOCUMENT ∞	38

*This confidential document is the property of NORTEL MATRA CELLULAR and may not be copied or circulated without permission
Ce document confidentiel est la propriété de NORTEL MATRA CELLULAR et ne peut être reproduit ou communiqué sans autorisation*

1. INTRODUCTION

1.1. OBJECT

This report presents the FCC regulatory assessment realized in order to introduce the ECELL 1900 BTS .

The new BTS is part of BTS evolution towards GPRS and EDGE : it is compatible with 8-PSK modulated signals and therefore ready to support EDGE functionalities in the future and with GMSK-modulated signals,

1.2. SCOPE

This document applies to the ECELL BTS GSM 1900 .
It is the Exhibit part of the FCC Part 24 Certification filling for Nortel AB6ECELL.

2. RELATED DOCUMENTS

2.1. APPLICABLE DOCUMENTS

[A1]	CFR 47 - Part 2	FREQUENCY ALLOCATIONS AND RADIO TREATY MATTERS; GENERAL RULES AND REGULATIONS
[A2]	CFR 47 - Part 24	PERSONAL COMMUNICATIONS SERVICES

2.2. REFERENCE DOCUMENTS

[R1] 149012DK GYL TECHNOLOGIES - EMC Test Report

3. ABBREVIATIONS & DEFINITIONS

3.1. ABBREVIATIONS

pRDRX	Driver Receiver Unit
BCF	Base Common Function
BTS	Base Transceiving Station
GSM	Global System for Mobile Communications
GPRS	General Packet Radio Service
EDGE	Enhanced Data for GSM Evolution
PA	Power Amplifier
LNA	Low Noise Amplifier
OMC	Operation and Maintenance Center
TCU	Trans-Coding Unit
MSC	Mobile Switching Center
RF	Radio Frequency
Tx	Transmitter

3.2. FREQUENCY DEFINITIONS

$$\text{For } 512 < n < 810 \quad F_{Rx}(n) = 1850.2 + 0.2*(n-512)$$

$$T_{Tx}(n) = F_{Rx}(n) + 80$$

Frequency Band and Channels

PCS 1900	C512	C661	C810
F Tx (MHz)	1930.2	1960	1989.8
F Rx (MHz)	1850.2	1880	1909.8

RF Local oscillator Frequencies :

	B	M	T
Channel number	512	661	885
Tx LO	1631.2	1661	1690.8
Rx LO	1639.2	1669	1698.8

Reference Synthesizer : 13 MHz

Intermediate Frequency RX synthesizer : 210.73 MHz

Intermediate Frequency TX synthesizer : 299 MHz

This confidential document is the property of NORTEL MATRA CELLULAR and may not be copied or circulated without permission
Ce document confidentiel est la propriété de NORTEL MATRA CELLULAR et ne peut être reproduit ou communiqué sans autorisation

4. EXHIBIT 1 : TEST REPORT

4.1. INTRODUCTION

The following information is submitted to introduce a Certification of a Broadband PCS Base Station for Northern Telecom, Inc., in accordance with FCC Part 24, Subpart E and Part 2, Subpart J of the FCC Rules and Regulations. The measurement procedures were in accordance with the requirements of Part 2.999.

4.2. MEASUREMENT RESULTS

Table 1 is a summary of the measurement results for this update.

Table 1 : Measurement Results Summary

FCC Measurement Specification	IC Limit Specification	Description	Result
2.1046	24.232	RF Power Output	Complies
2.1047		Modulation characteristics	Complies
2.1049		Occupied Bandwidth	Complies
2.1051, 2.1057	24.238	Spurious Emissions at Antenna Terminals	Complies
2.1053, 2.1057	24.238	Field Strength of Spurious Radiation	Bull report
2.1055	24.235	Frequency Stability	Complies
1.1307	1.1310	RF Exposure	Not tested

*This confidential document is the property of NORTEL MATRA CELLULAR and may not be copied or circulated without permission
Ce document confidentiel est la propriété de NORTEL MATRA CELLULAR et ne peut être reproduit ou communiqué sans autorisation*

4.3. NAME OF TEST : 2.1046 RF POWER OUTPUT

4.3.1. FCC REQUIREMENTS

4.3.1.1. *FCC Part 24.232*

- (a) Base stations are limited to 1640 watts peak equivalent isotropically radiated power (e.i.r.p.) with an antenna height up to 300 meters HAAT. See 24.53 for HAAT calculation method. Base station antenna heights may exceed 300 meters with a corresponding reduction in power. In no case may the peak output power of a base station transmitter exceed 100 watts

- (b) Peak transmit power must be measured over any interval of continuous transmission using instrumentation calibrated in terms of an rms-equivalent voltage. The measurement results shall be properly adjusted for any instrument limitations, such as detector response times, limited resolution bandwidth capability when compared to the emission bandwidth, sensitivity, etc., so as to obtain a true peak measurement for the emission in question over the full bandwidth of the channel.

This confidential document is the property of NORTEL MATRA CELLULAR and may not be copied or circulated without permission
Ce document confidentiel est la propriété de NORTEL MATRA CELLULAR et ne peut être reproduit ou communiqué sans autorisation

4.3.2. TEST RESULTS

Table 1 shows the test results for RF Output Power.

Band	Radio Channel	Frequency (MHz)	Measured RF Output Power (dBm)		Maximum Rated Power (dBm)	Limit (dBm)
			TDMA0	TDMA1		
A	513	1930,4	32,3	31,2	32	50
A	548	1937,4	32,5	31,2	32	50
A	585	1944,8	32,5	31,2	32	50
D	587	1945,2	32,6	31,2	32	50
D	598	1947,4	32,6	31,2	32	50
D	610	1949,8	32,5	31,2	32	50
B	612	1950,2	32,5	31,2	32	50
B	648	1957,4	32,5	31,2	32	50
B	685	1964,8	32,4	31,2	32	50
E	687	1965,2	32,4	31,2	32	50
E	698	1967,4	32,4	31,2	32	50
E	710	1969,8	32,4	31,2	32	50
F	712	1970,2	32,4	31,2	32	50
F	723	1972,4	32,4	31,2	32	50
F	735	1974,8	32,4	31,2	32	50
C	737	1975,2	32,4	31,2	32	50
C	773	1982,4	32,1	31,2	32	50
C	809	1989,6	32,1	31,2	32	50

*This confidential document is the property of NORTEL MATRA CELLULAR and may not be copied or circulated without permission
Ce document confidentiel est la propriété de NORTEL MATRA CELLULAR et ne peut être reproduit ou communiqué sans autorisation*

4.3.3. TEST PROCEDURE

The equipment was configured as shown in figure 1.

Figure 1 : Test configuration for RF Output Power

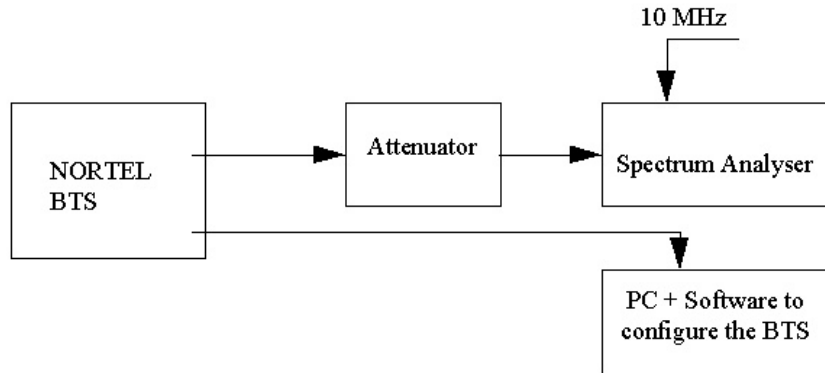

The BTS was configured to transmit at maximum power (static level 0). Measurements were made at frequencies which are the bottom, middle and top of each of the licensed blocks.

The peak output power was measured using the spectrum analyzer which had the following settings :

Resolution bandwidth :	300 kHz
Video bandwidth :	1 MHz
Span :	0 Hz
Reference level :	45 dBm
Reference Level Offset :	Corrected to account for cable(s) and attenuator losses
Level range :	10 dB
Sweep time :	5 ms

4.4. NAME OF TEST : 2.1049 OCCUPIED BANDWIDTH

4.4.1. FCC REQUIREMENTS

4.4.1.1. FCC Part 2.1049

The occupied bandwidth is defined as the width of the signal between two points, one below the carrier center frequency and one above the carrier center frequency, outside of which all emissions are attenuated at least 23 dB below the transmitter power.

4.4.2. TEST RESULTS

The maximum occupied bandwidth was found to be 308.6 kHz (measured on channel 661, $f = 1960.0$ MHz).

Figure 1: Sample plot for occupied bandwidth TDMA 0 :

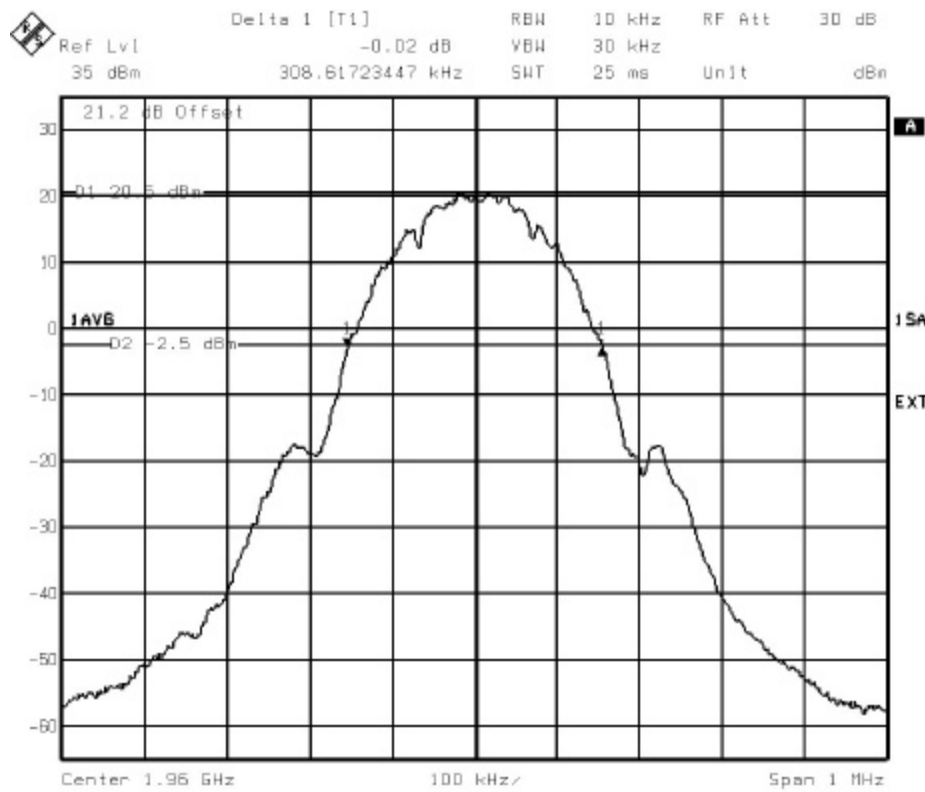

*This confidential document is the property of NORTEL MATRA CELLULAR and may not be copied or circulated without permission
Ce document confidentiel est la propriété de NORTEL MATRA CELLULAR et ne peut être reproduit ou communiqué sans autorisation*

Figure 2: Sample plot for occupied bandwidth TDMA 1 :

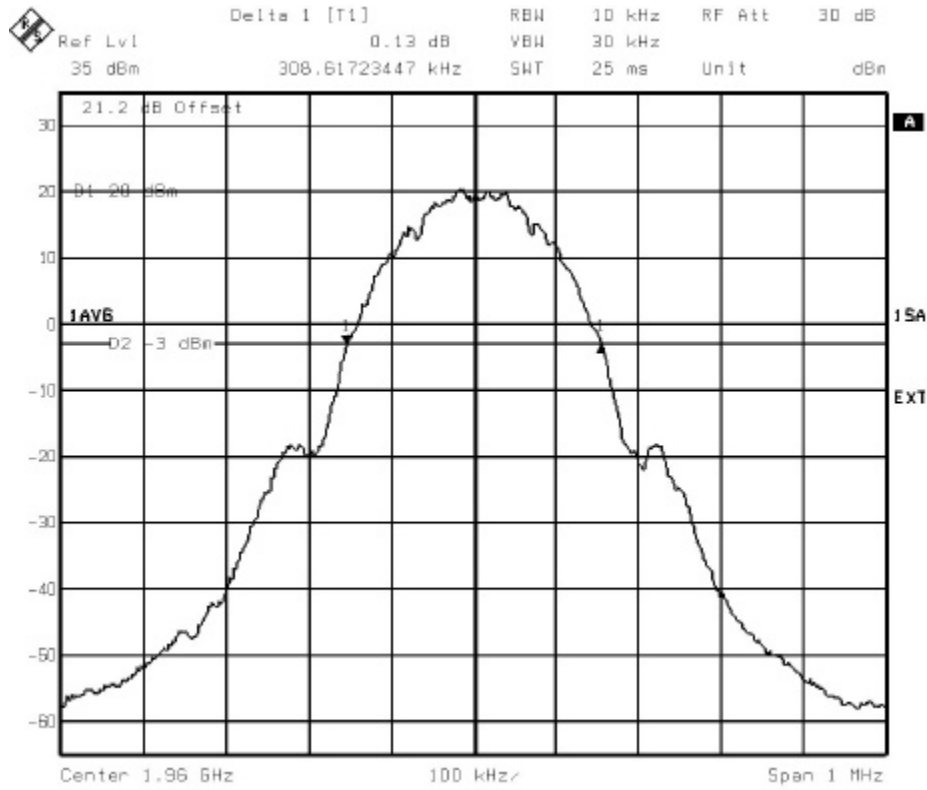

*This confidential document is the property of NORTEL MATRA CELLULAR and may not be copied or circulated without permission
 Ce document confidentiel est la propriété de NORTEL MATRA CELLULAR et ne peut être reproduit ou communiqué sans autorisation*

4.4.3. TEST PROCEDURE

The equipment was configured as shown in figure 2.

Figure 2 : Test configuration for Occupied bandwidth

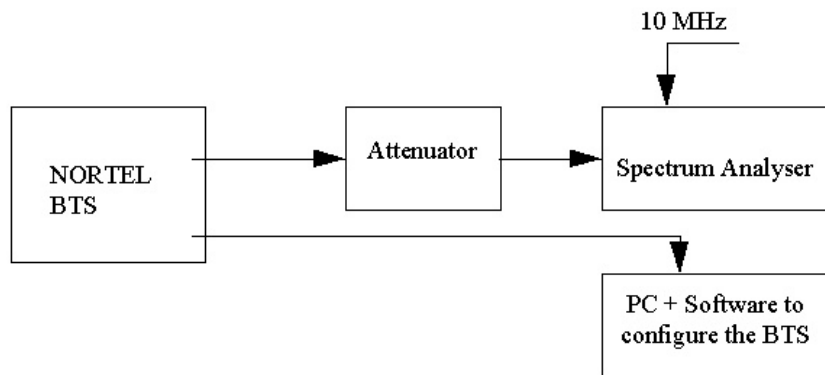

The BTS was configured to transmit at maximum power (Static Level 0). Measurements were made at frequencies which were at the bottom and top of the transmit band.

The occupied bandwidth was measured by determining the bandwidth out of which all emissions are attenuated at least 23 dB below the transmitter power.

The spectrum analyzer had the following settings :

Resolution bandwidth :	10 kHz
Video bandwidth :	30 kHz
Span :	1 MHz
Reference level :	35 dBm
Reference Level Offset :	Corrected to account for cable(s) and attenuator losses
Level range :	100 dB
Sweep time :	25 ms

4.5. NAME OF TEST : 2.1051 SPURIOUS EMISSIONS AT ANTENNA TERMINALS

4.5.1. FCC REQUIREMENTS

4.5.1.1. FCC Part 24.238

- (a) On any frequency outside a licensee's frequency block, the power of any emission shall be attenuated below the transmitter power (P) by at least $43 + 10 \log (P)$ dB.
- (b) Compliance with these provisions is based on the use of measurement instrumentation employing a resolution bandwidth of 1 MHz or greater. However, in the 1 MHz bands immediately outside and adjacent to the frequency block a resolution bandwidth of at least one percent of the emission bandwidth of the fundamental emission of the transmitter may be employed. The emission bandwidth is defined as the width of the signal between two points, one below the carrier center frequency and one above the carrier center frequency, outside of which all emissions are attenuated at least 23 dB below the transmitter power.
- (c) When measuring the emission limits, the nominal carrier frequency shall be adjusted as close to the licensee's frequency block edges, both upper and lower, as the design permits.
- (d) The measurements of emission power can be expressed in peak or average values, provided they are expressed in the same parameters as the transmitter power.

4.5.2. TEST RESULTS

The reference level for spurious emissions at the antenna terminals is taken from the measured output power (32 dBm = 1.6 Watts).

Therefore the spurious emissions must be attenuated by at least $43 + 10 * \text{Log}(1.6) = 45$ dB. The measured output power was 32 dBm ; therefore the limit is $32 - 45 = -13$ dBm.

Tables 2 and 3 show the results for Spurious Emissions at Antenna Terminals.

Table 2 : Test results for Spurious Emissions at Antenna Terminals

		TDMA0			TDMA1		
	Channel number	Spurious emissions level [dBm]	Limit [dBm]	Margin [dBm]	Spurious emissions level [dBm]	Limit [dBm]	Margin [dBm]
A	512	-22,6	-13	9,6	-23,8	-13	10,8
A	585	-22,6	-13	9,6	-22,3	-13	9,3
D	587	-22,6	-13	9,6	-22,9	-13	9,9
D	610	-22,3	-13	9,3	-22,7	-13	9,7
B	612	-22,9	-13	9,9	-22,7	-13	9,7
B	685	-22,3	-13	9,3	-21,7	-13	8,7
E	687	-22,3	-13	9,3	-22,4	-13	9,4
E	710	-22,1	-13	9,1	-21,9	-13	8,9
F	712	-22,5	-13	9,5	-21,8	-13	8,8
F	735	-21,9	-13	8,9	-21,2	-13	8,2
C	737	-22,9	-13	9,9	-21,9	-13	8,9
C	810	-23,3	-13	10,3	-22,1	-13	9,1

*This confidential document is the property of NORTEL MATRA CELLULAR and may not be copied or circulated without permission
Ce document confidentiel est la propriété de NORTEL MATRA CELLULAR et ne peut être reproduit ou communiqué sans autorisation*

Table 3 : Test results for Spurious Emissions at Antenna Terminals

TDMA0

Frequency (MHz)	Spurious Emissions Level (dBm)	Limit (dBm)	Margin (dB)
41.9	-63.3	-13	50.3
46.8	-43.4	-13	30.4
485.57	-44.6	-13	31.6
1967.25	-42	-13	29
1973.8	-56.4	-13	43.4
1974.48	-66.3	-13	53.3
1991	-32.9	-13	19.9
3762.9	-26.4	-13	13.4
6893.7	-23.8	-13	10.8
10949.9	-21.6	-13	8.6
12336.7	-21.6	-13	8.6

TDMA1

Frequency (MHz)	Spurious Emissions Level (dBm)	Limit (dBm)	Margin (dB)
26	-62.8	-13	49.8
32.5	-44.5	-13	31.5
498.2	-43.8	-13	30.8
1934.8	-42	-13	29
1972.4	-55.7	-13	42.7
1974.95	-65.9	-13	52.9
1991	-32.1	-13	20.1
3835.2	-27.2	-13	14.2
6998	-23.6	-13	10.6
10958	-23.1	-13	10.1
19777	-22.3	-13	9.3

*This confidential document is the property of NORTEL MATRA CELLULAR and may not be copied or circulated without permission
Ce document confidentiel est la propriété de NORTEL MATRA CELLULAR et ne peut être reproduit ou communiqué sans autorisation*

Notes :

Figure 3 and Figure 4 show sample plots for the case when the transmitter was tuned to Channel 512 (lowest channel in Tx band) for TDMA0.

Figure 5 and figure 6 shows a sample plots for the case when the transmitter was tuned to Channel 810 (highest channel in Tx band) for TDMA0.

Figure 10 to Figure 16 show sample plots for frequency spans from 0 to 20 GHz with emission on channel 810 (Pmax).

*This confidential document is the property of NORTEL MATRA CELLULAR and may not be copied or circulated without permission
Ce document confidentiel est la propriété de NORTEL MATRA CELLULAR et ne peut être reproduit ou communiqué sans autorisation*

Figure 3 : -1 MHz adjacent band (TDMA0, Channel 512, Pmax)

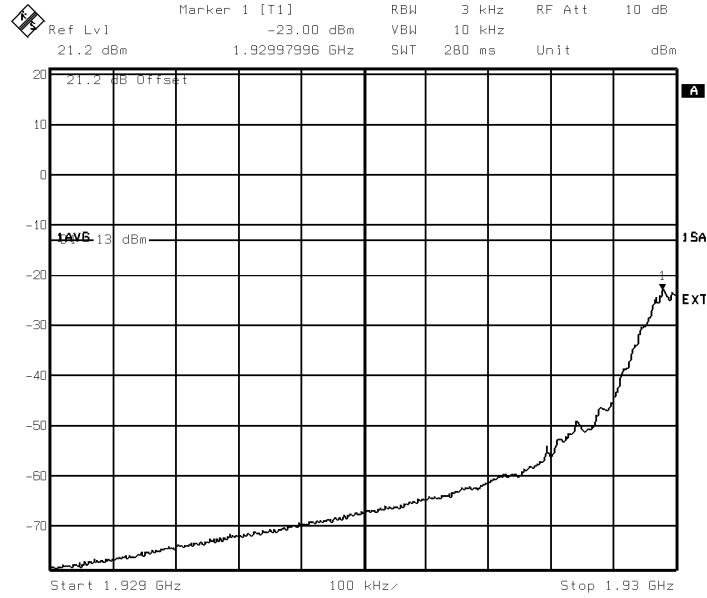
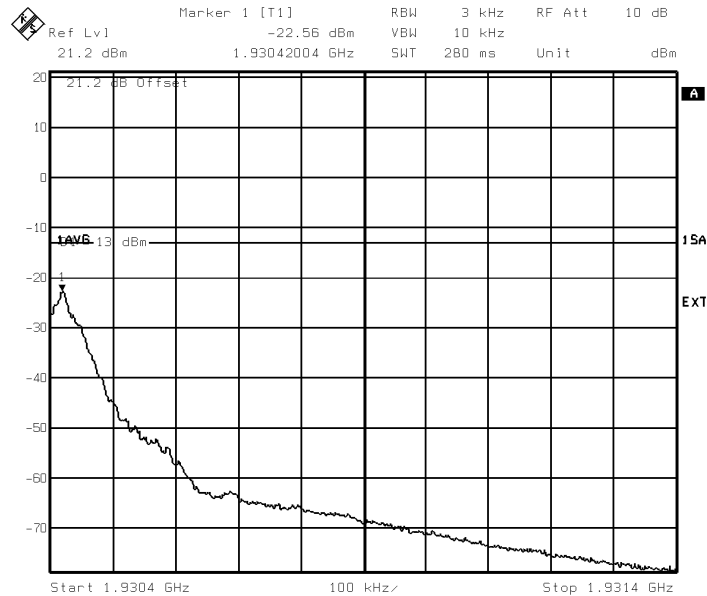

Figure 4 : +1 MHz adjacent band (TDMA0, Channel 512, Pmax)



*This confidential document is the property of NORTEL MATRA CELLULAR and may not be copied or circulated without permission
 Ce document confidentiel est la propriété de NORTEL MATRA CELLULAR et ne peut être reproduit ou communiqué sans autorisation*

Figure 5 : -1 MHz adjacent band (TDMA0, Channel 810, Pmax)

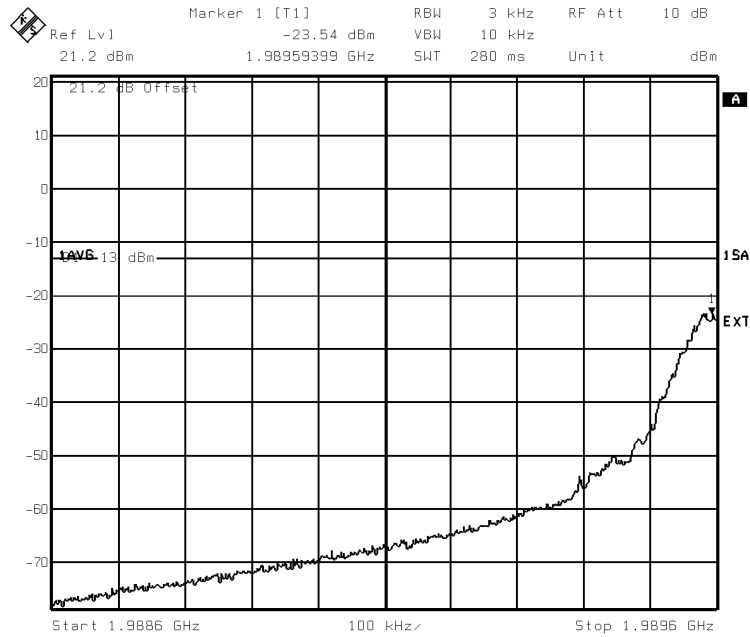

Figure 6 : +1 MHz adjacent band (TDMA0, Channel 810, Pmax)



*This confidential document is the property of NORTEL MATRA CELLULAR and may not be copied or circulated without permission
Ce document confidentiel est la propriété de NORTEL MATRA CELLULAR et ne peut être reproduit ou communiqué sans autorisation*

Figure 7 : -1 MHz adjacent band (TDMA1, Channel 512, Pmax)

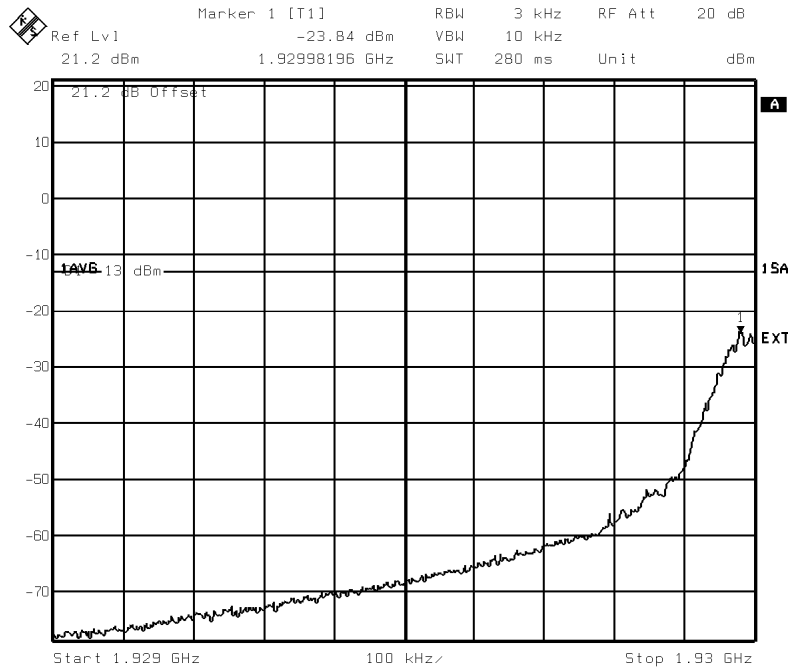
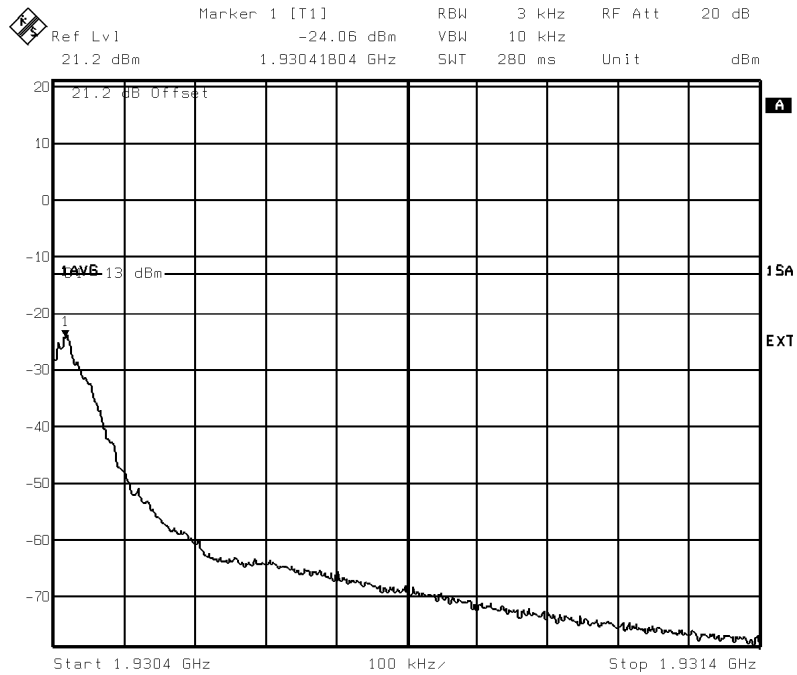

Figure 8 : +1 MHz adjacent band (TDMA1, Channel 512, Pmax)



*This confidential document is the property of NORTEL MATRA CELLULAR and may not be copied or circulated without permission
Ce document confidentiel est la propriété de NORTEL MATRA CELLULAR et ne peut être reproduit ou communiqué sans autorisation*

Figure 8 : -1 MHz adjacent band (TDMA1, Channel 810, Pmax)

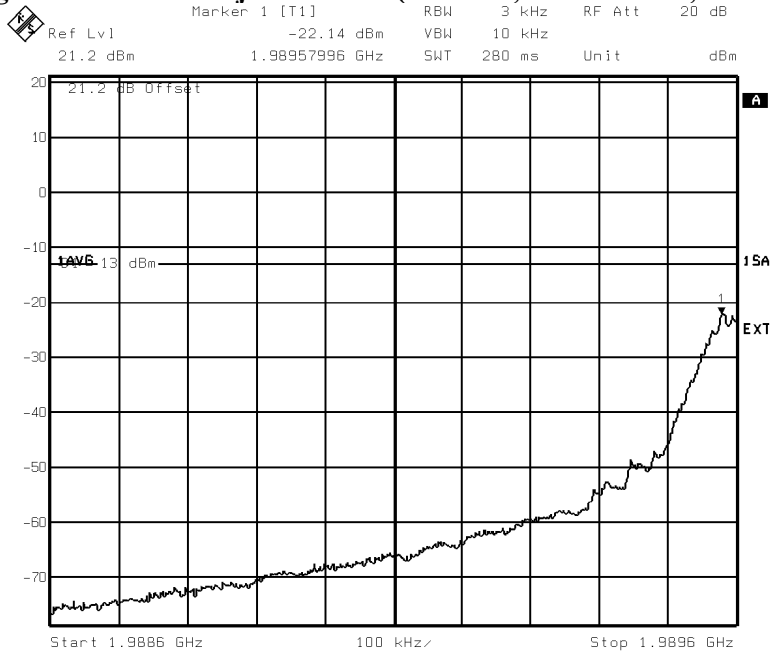
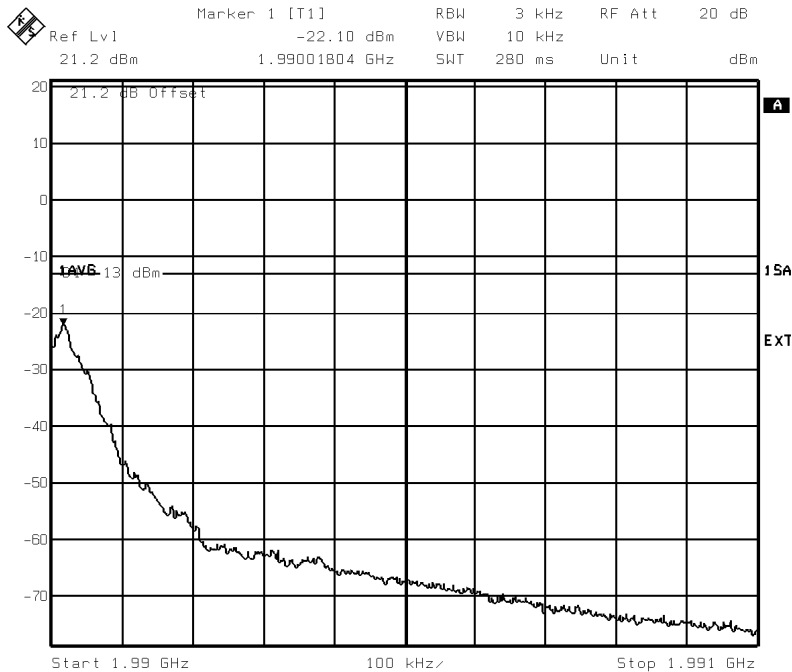
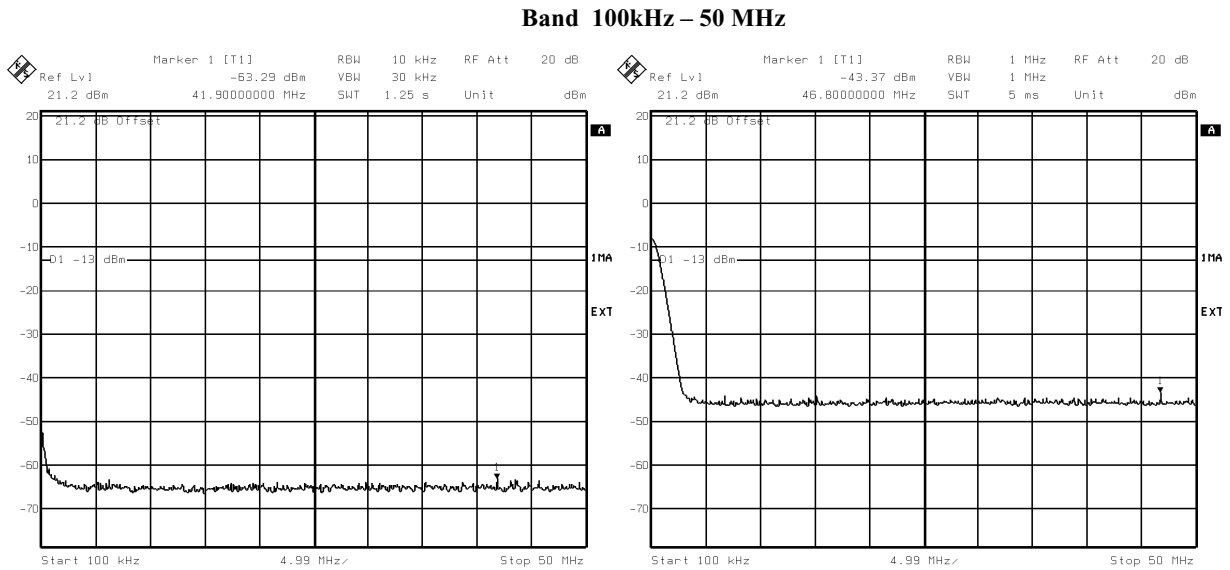

Figure 9 : +1 MHz adjacent band (TDMA1, Channel 810, Pmax)



*This confidential document is the property of NORTEL MATRA CELLULAR and may not be copied or circulated without permission
Ce document confidentiel est la propriété de NORTEL MATRA CELLULAR et ne peut être reproduit ou communiqué sans autorisation*

Figure 10 : Out of block emissions (TDMA0, Channel 810, Pmax)



RBW = 10 kHz

RBW = 1 MHz (*)

(*) Note : spectrum lines at 100 kHz is internal DC spectrum line of analyzer.

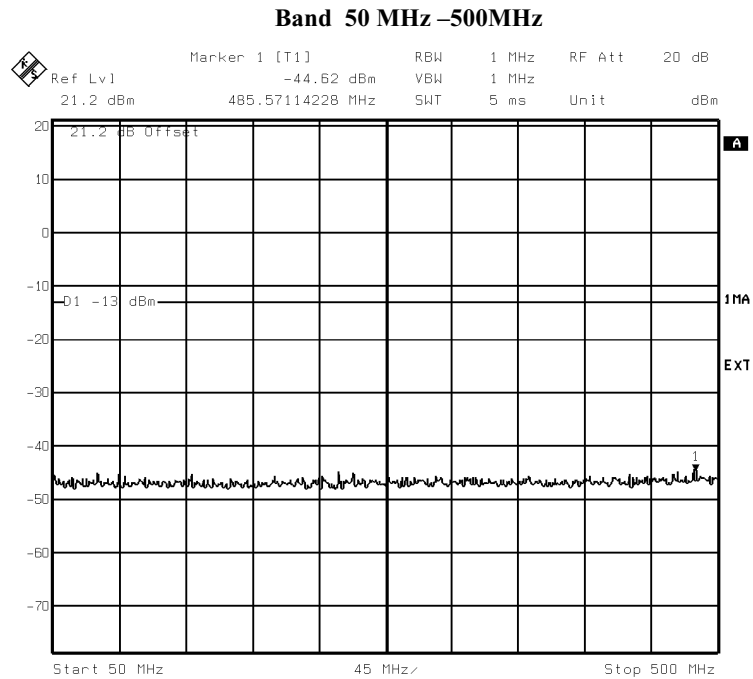

*This confidential document is the property of NORTEL MATRA CELLULAR and may not be copied or circulated without permission
 Ce document confidentiel est la propriété de NORTEL MATRA CELLULAR et ne peut être reproduit ou communiqué sans autorisation*

Band 500 MHz- 1970.2 MHz

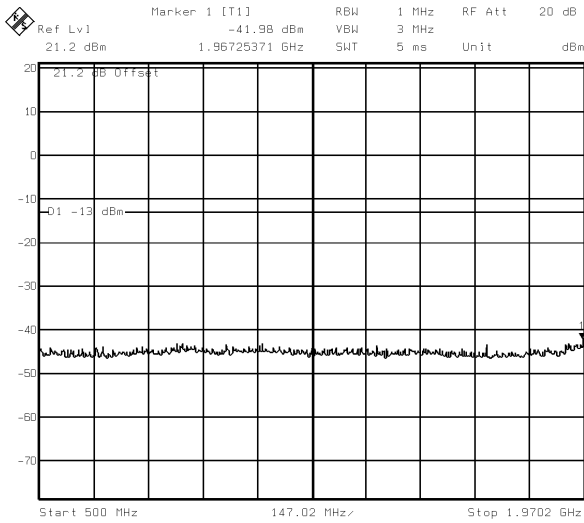

Band 1970.2 – 1974 MHz

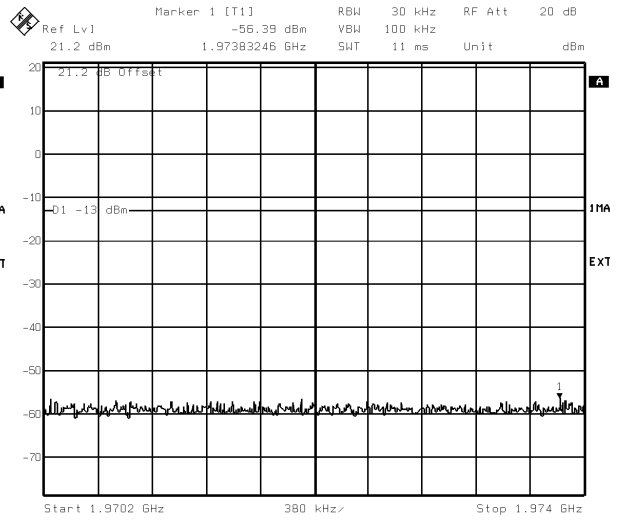

Band 1974 MHz - 1975 MHz

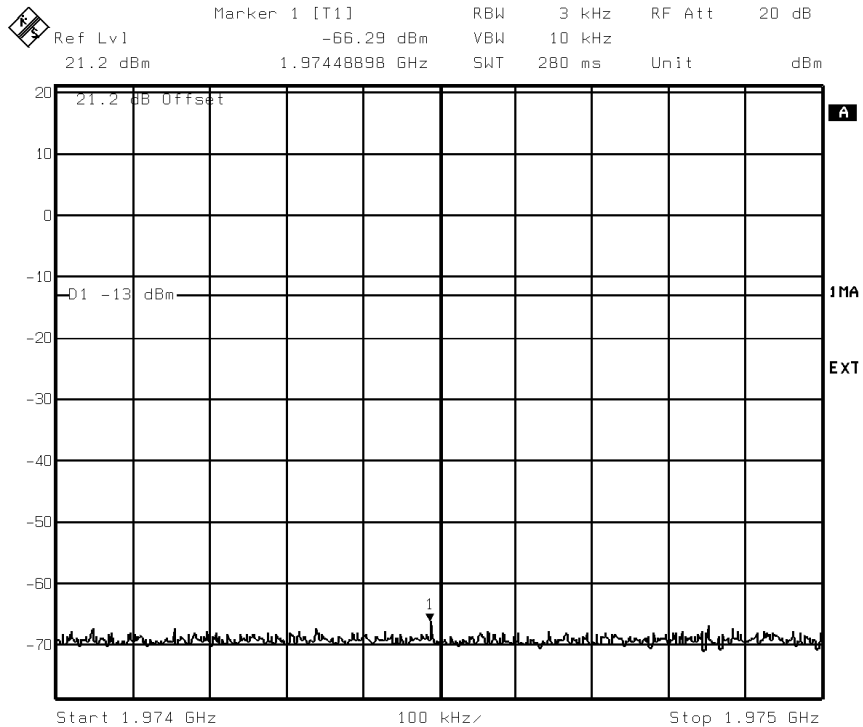

*This confidential document is the property of NORTEL MATRA CELLULAR and may not be copied or circulated without permission
Ce document confidentiel est la propriété de NORTEL MATRA CELLULAR et ne peut être reproduit ou communiqué sans autorisation*

Figure 11 : Out of block emissions (TDMA0, Channel 810, Pmax)

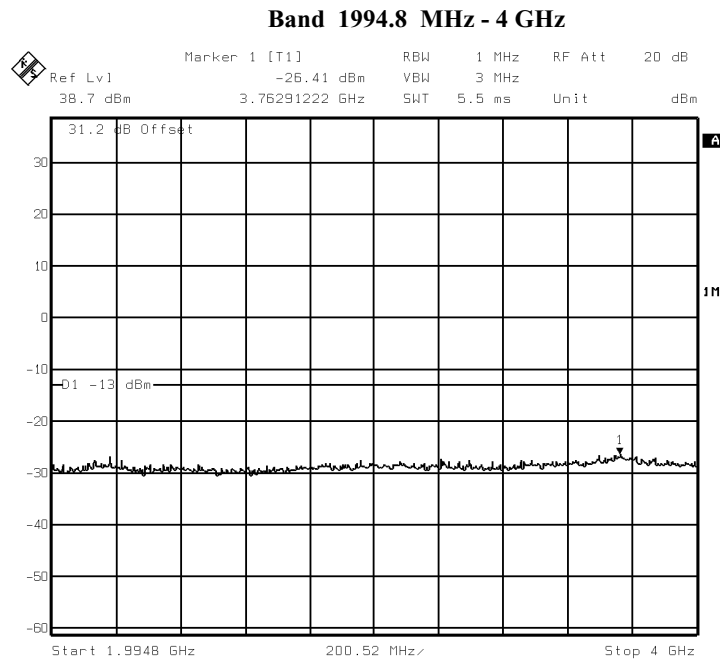
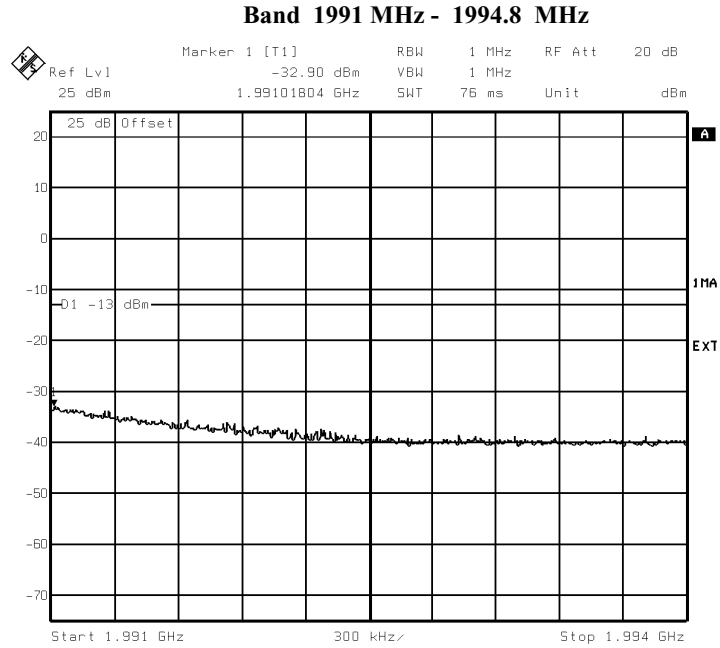

*This confidential document is the property of NORTEL MATRA CELLULAR and may not be copied or circulated without permission
Ce document confidentiel est la propriété de NORTEL MATRA CELLULAR et ne peut être reproduit ou communiqué sans autorisation*

Figure 12 : Out of block emissions (TDMA0, Channel 810, Pmax)

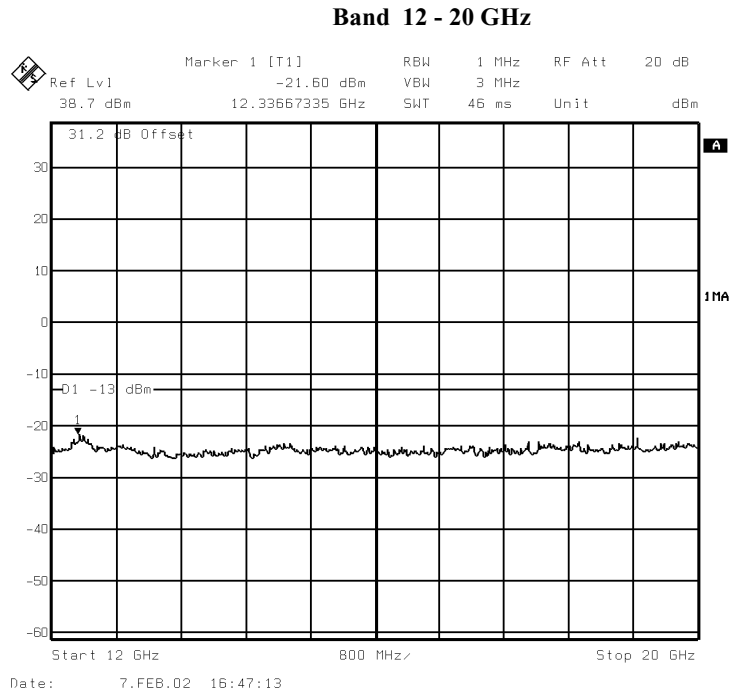
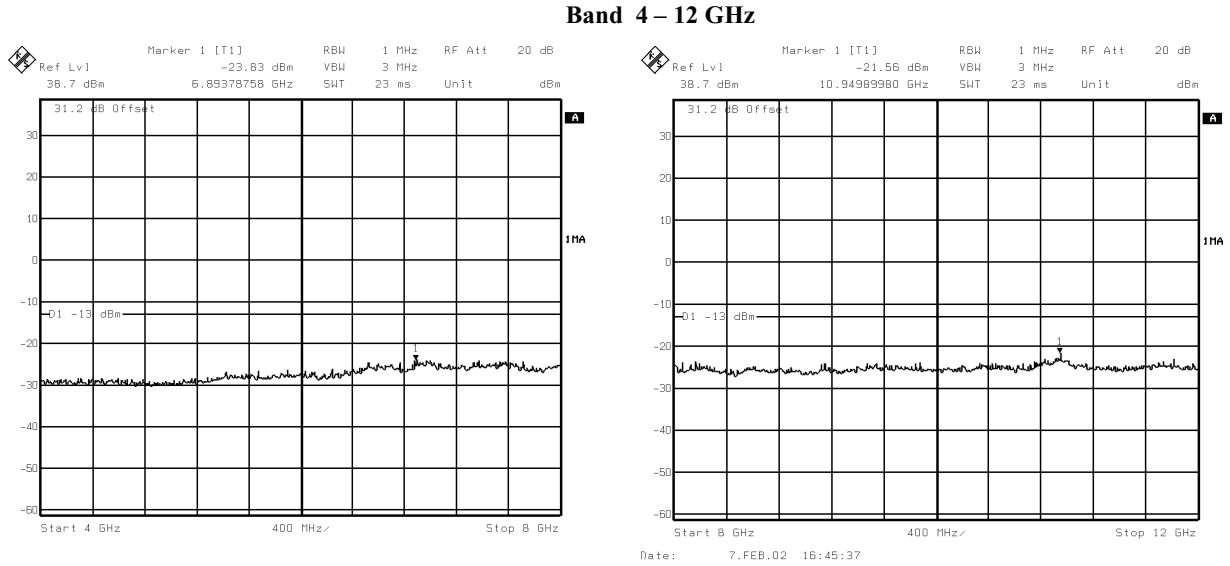

*This confidential document is the property of NORTEL MATRA CELLULAR and may not be copied or circulated without permission
Ce document confidentiel est la propriété de NORTEL MATRA CELLULAR et ne peut être reproduit ou communiqué sans autorisation*

Figure 13 : Out of block emissions (TDMA1, Channel 810, Pmax)

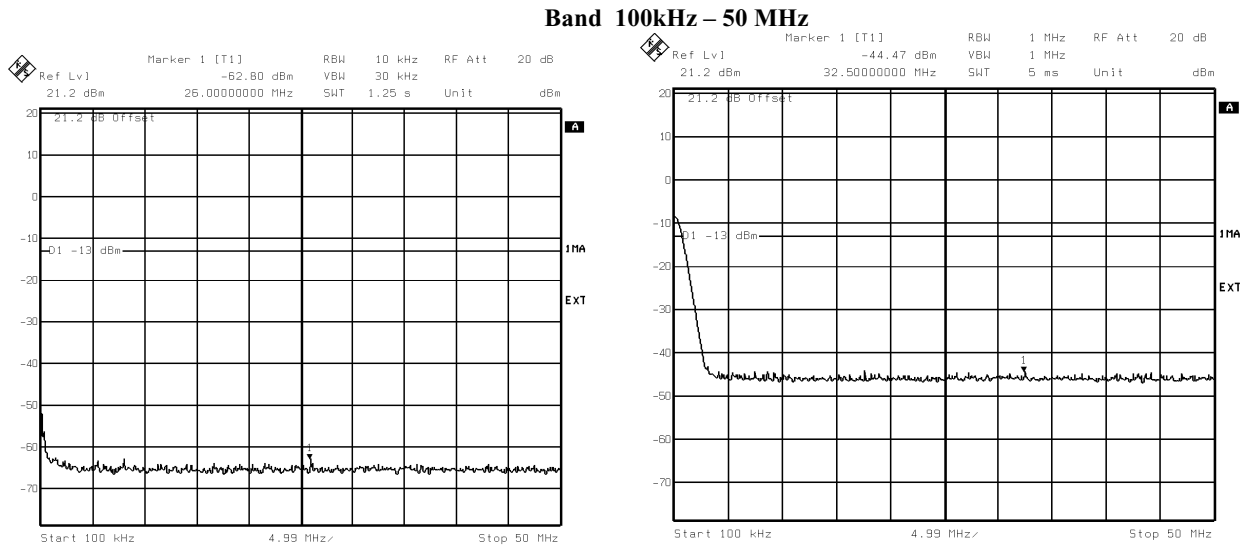

RBW = 10 kHz

RBW = 1 MHz (*)

(*) Note : spectrum lines at 100 kHz is internal DC spectrum line of analyzer.

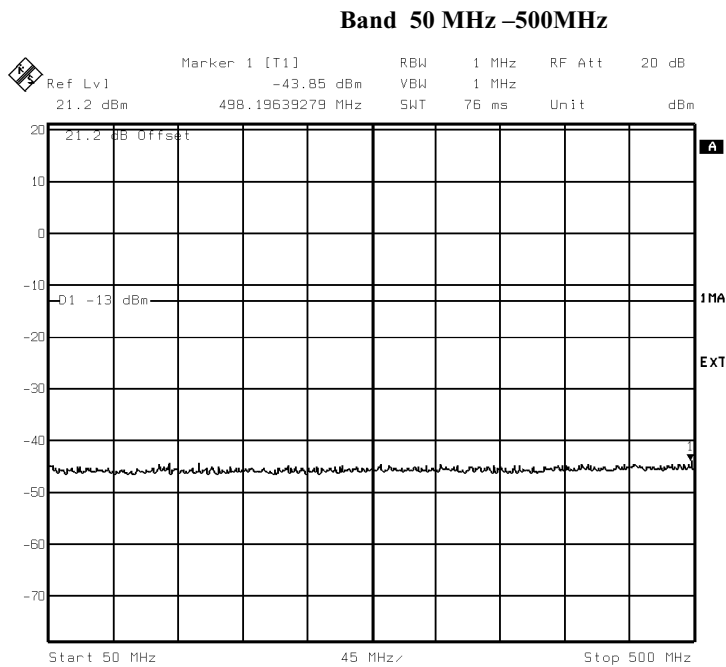

*This confidential document is the property of NORTEL MATRA CELLULAR and may not be copied or circulated without permission
 Ce document confidentiel est la propriété de NORTEL MATRA CELLULAR et ne peut être reproduit ou communiqué sans autorisation*

Figure 14 : Out of block emissions (TDMA1, Channel 810, Pmax)

Band 500 MHz- 1970.2 MHz

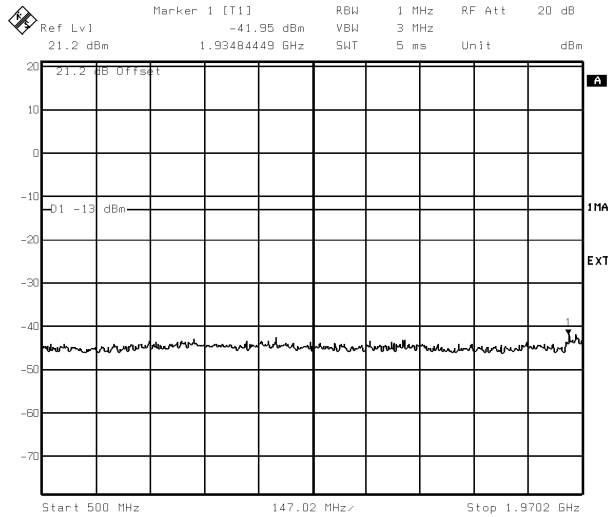

Band 1970.2 – 1974 MHz

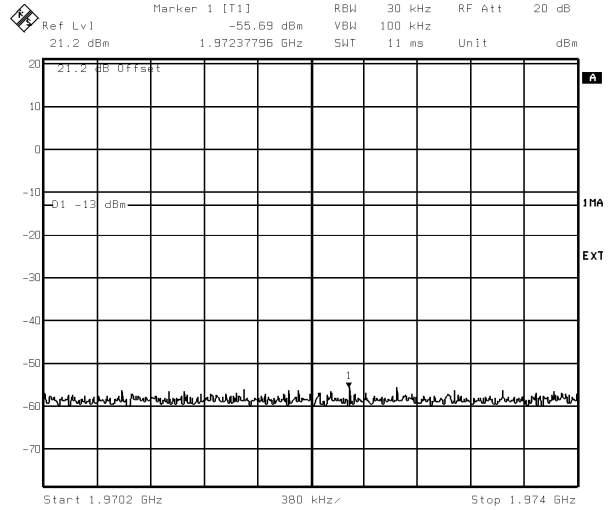

Band 1974 MHz - 1975 MHz

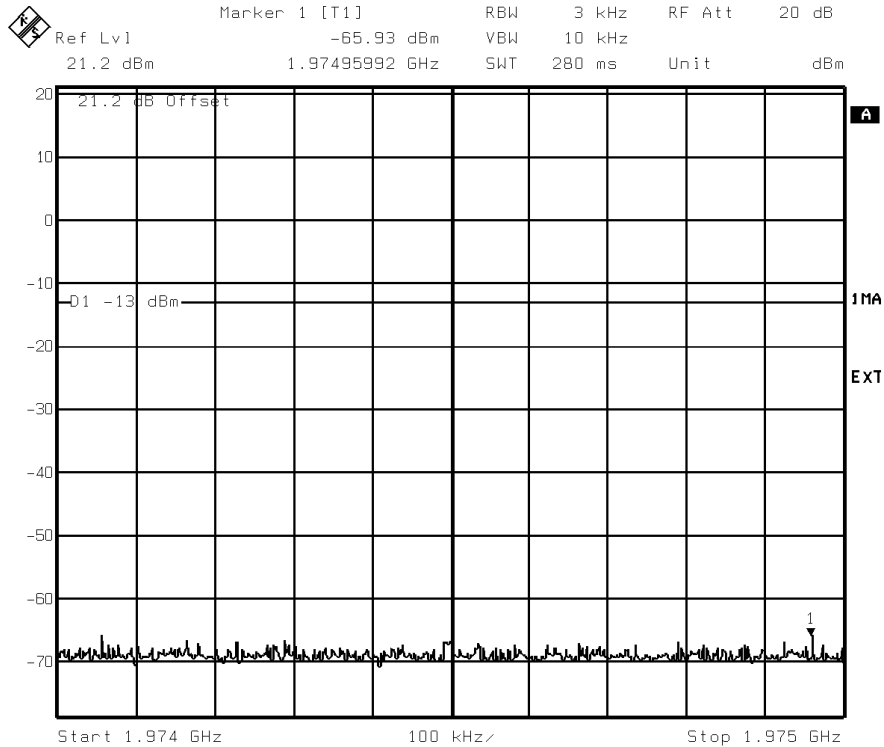

*This confidential document is the property of NORTEL MATRA CELLULAR and may not be copied or circulated without permission
Ce document confidentiel est la propriété de NORTEL MATRA CELLULAR et ne peut être reproduit ou communiqué sans autorisation*

Figure 15 : Out of block emissions (TDMA1, Channel 810, Pmax)

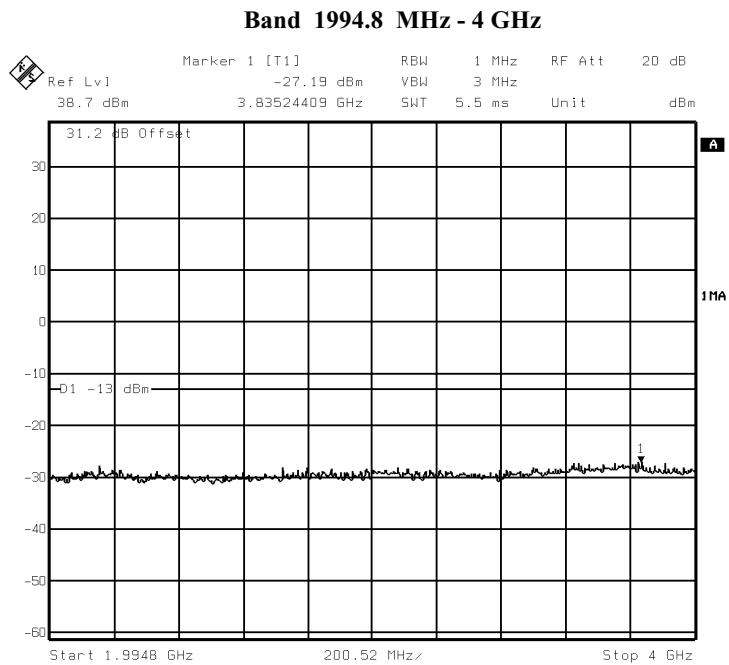
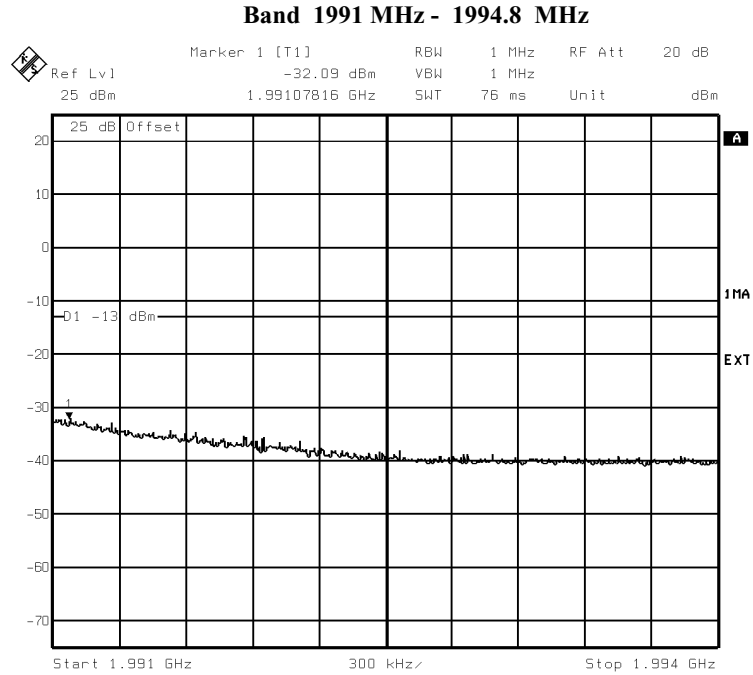

*This confidential document is the property of NORTEL MATRA CELLULAR and may not be copied or circulated without permission
Ce document confidentiel est la propriété de NORTEL MATRA CELLULAR et ne peut être reproduit ou communiqué sans autorisation*

Figure 16 : Out of block emissions (TDMA1, Channel 810, Pmax)

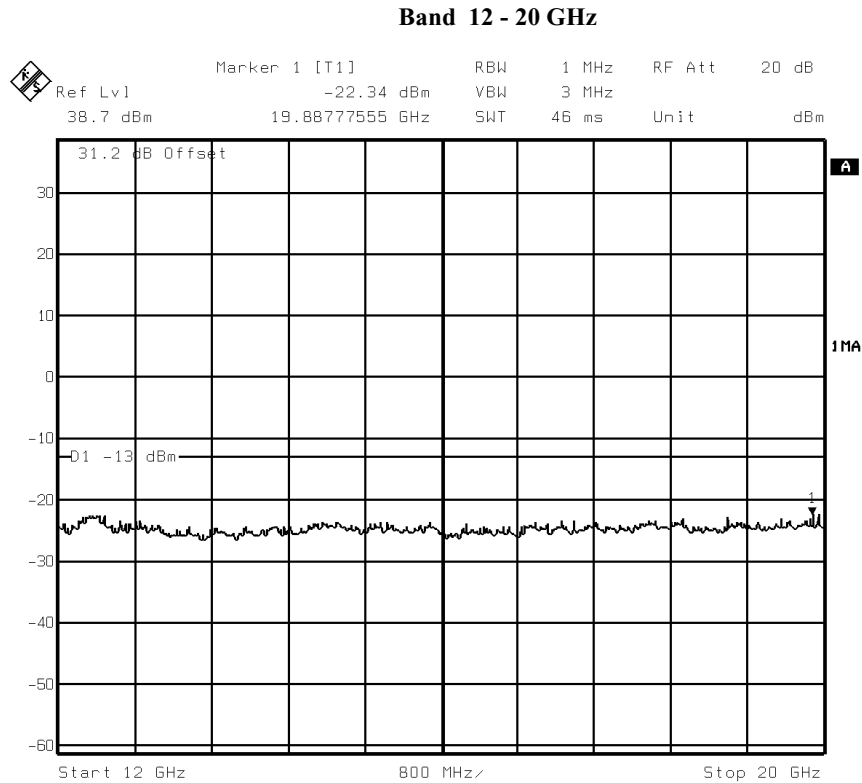
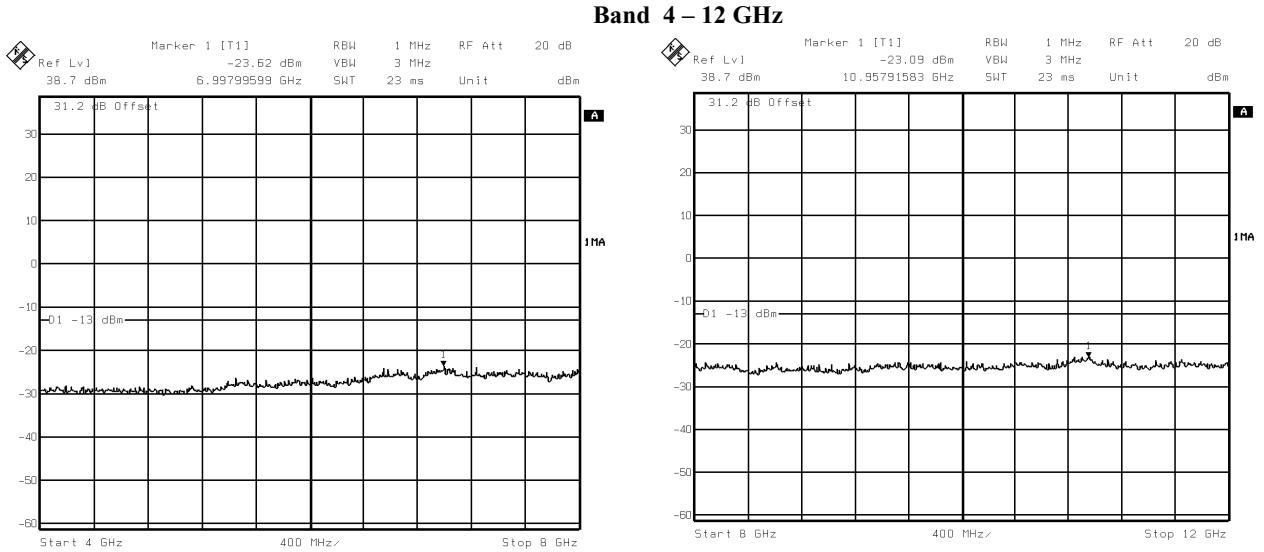

*This confidential document is the property of NORTEL MATRA CELLULAR and may not be copied or circulated without permission
Ce document confidentiel est la propriété de NORTEL MATRA CELLULAR et ne peut être reproduit ou communiqué sans autorisation*

Measurements were also performed when the BTS was maximum power on channels adjacent to band edge channels and it was found that the emission requirements were met with greater than 8 dB margin in the 1 MHz adjacent frequency band.

4.5.3. TEST PROCEDURE

The equipment was configured as shown in figure 11.

Figure 11 : Test configuration for Spurious emissions at antenna terminals

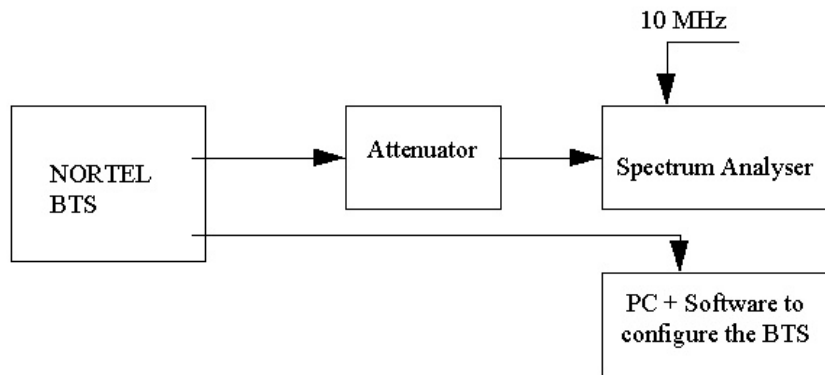

For adjacent channels emissions, the BTS nominal carrier frequency was adjusted to each block edge channel.

Channels 512 and 810 are those channels which are at the lower and upper edges of the PCS band respectively.

The transmitter was set to operate to maximum power in Tx activation mode TCH_13K.

For these measurements, the resolution bandwidth was of the spectrum analyzer was set to at least 1% of the emission bandwidth. In this case the emission bandwidth measured was 308.6 kHz. Therefore, the resolution bandwidth was set to 3 kHz.

The spectrum analyzer had the following settings for adjacent band

Resolution bandwidth :	3 kHz
Video bandwidth :	10 kHz
Span :	1 MHz
Reference level :	10 dBm
Reference Level Offset :	Corrected to account for cable(s), filter and attenuator losses
Level range :	100 dB
Sweep time :	Coupled
Detector :	Sample
Trace :	Average
Sweep count :	200

For all other measurements the BTS carrier frequency was adjusted to Channel 810.

The spectrum analyzer had the following settings for out of block emissions.

Resolution bandwidth :	1 MHz
Video bandwidth :	1 MHz
Detector :	Sample
Trace :	Max hold

For the band 1991– 1994.8 MHz , bench measurement uses an additional Notch Filter (reject bandwidth = 1MHz) to reject carrier (1989.8MHz) and allows to measure spurious in 1991– 1994.8 MHz using RBW=1MHz.

The emissions were investigated up to the tenth harmonic of the fundamental emission (20 GHz).

The measured level of the emissions was recorded and compared to the -13 dBm limit.

4.6. NAME OF TEST : 2.1055 FREQUENCY STABILITY

4.6.1. FCC REQUIREMENTS

4.6.1.1. FCC Part 24.235

The frequency stability shall be sufficient to ensure that the fundamental emission stays within the authorized frequency block.

4.6.2. TEST RESULTS

Tables 4 shows the BTS 1900 ECELL Frequency Stability in extreme conditions for channel B,M,T.

Table 4a : Frequency Stability TDMA0

BTS Temp. [°C]	TDMA0 MAXIMUM carrier frequency deviation [Hz]								
	Channel 512 @ DC supply voltage:			Channel 661 @ DC supply voltage:			Channel 810 @ DC supply voltage:		
	40V	48V	57V	40V	48V	57V	40V	48V	57V
-30	-17,43	-18,14	-18,4	14,79	15,76	14,46	24,34	25,12	28,22
-20	19,11	19,63	19,89	22,02	24,02	25,51	35,84	39,71	32,8
-10	33,45	34,29	36,94	33,13	31,83	33,13	18,02	20,28	22,6
0	24,47	24,02	26,8	28,86	26,22	29,25	38,03	34,8	39,78
10	18,47	21,05	16,53	15,24	14,21	15,83	34,03	33,06	30,48
20	11,62	14,66	14,85	22,08	19,5	20,28	19,82	25,87	27,41
30	14,21	19,5	-24,15	21,63	29,79	-22,21	24,15	24,6	13,04
40	24,1	19,22	18,71	19,63	21,7	21,63	24,73	22,47	25,7
50	14,21	17,5	-25,5	19,31	14,92	-20,9	-22,6	-18,85	22,92

Table 4b : Frequency Stability TDMA1

BTS Temp. [°C]	TDMA1 MAXIMUM carrier frequency deviation [Hz]								
	Channel 512 @ DC supply voltage:			Channel 661 @ DC supply voltage:			Channel 810 @ DC supply voltage:		
	40V	48V	57V	40V	48V	57V	40V	48V	57V
-30	-19,76	-15,43	-14,14	19,5	15,69	19,82	31,64	26,73	29,51
-20	31,5	20,15	19,05	30,28	24,6	31,06	32,54	35,77	34,03
-10	38,23	39,91	38,48	33,96	38,1	22,86	30,61	30,99	28,67
0	30,22	27,12	27,44	32,09	36,29	33,9	34,22	37,06	36,61
10	24,73	10,01	11,46	26,15	26,6	25,05	30,8	32	28,3
20	17,95	21,31	14,66	-14,14	-13,3	26,8	24,53	27,32	32,26
30	21,5	20,21	24,02	19,69	-17,63	20,15	22,73	26,93	23,57
40	19,89	24,28	23,76	22,28	25,18	22,54	27,06	28,15	26,54
50	-16,92	16,01	19,5	-16,79	-20,08	-21,57	23,18	23,5	23,25

*This confidential document is the property of NORTEL MATRA CELLULAR and may not be copied or circulated without permission
Ce document confidentiel est la propriété de NORTEL MATRA CELLULAR et ne peut être reproduit ou communiqué sans autorisation*

The maximum frequency deviation allowed is 89 Hz.

The maximum deviation measured better than 40Hz is sufficient to ensure that the fundamental emission stays within the authorized frequency block.

The ECELL BTS GSM1900 still complies with the requirement.

4.6.3. TEST PROCEDURE

A period of at least one hour was allowed prior to measurement to ensure that all of the components of the oscillator circuit had stabilized at each temperature.

The equipment was configured as shown in figure 12.

Figure 12 : Test configuration for Frequency Stability

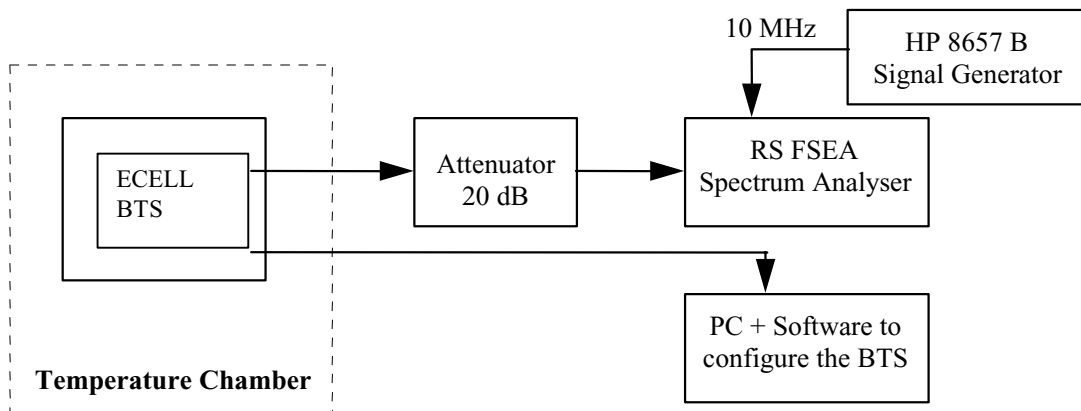

*This confidential document is the property of NORTEL MATRA CELLULAR and may not be copied or circulated without permission
Ce document confidentiel est la propriété de NORTEL MATRA CELLULAR et ne peut être reproduit ou communiqué sans autorisation*

4.7. NAME OF TEST : 2. 1053 FIELD STRENGTH OF SPURIOUS RADIATION

4.7.1. FCC REQUIREMENTS

4.7.1.1. FCC Part 24.238

(a) On any frequency outside a licensee's frequency block, the power of any emission shall be attenuated below the transmitter power (P) by at least 43 + 10 log (P) dB.

4.7.1.2. FCC Part 2.1053

(a) Measurements shall be made to detect spurious emissions that may be radiated directly from the cabinet, control circuits, power leads, or intermediate circuit elements under normal conditions of installation and operation. Curves or equivalent data shall be supplied showing the magnitude of each harmonic and other spurious emission.

4.7.2. TEST RESULTS

Measurement is done with all transmitters.

Table 5 shows the results for radiated spurious emissions measurements.

Table 5 : Test results for spurious emissions

Antenna Polarization	Frequency (MHz)	Measured Level (dBμV)	Correction Factor (dB)	Corrected Level (dBμV/m)	Limit (dBμV/m) @ 1 m
Vertical	1930.2	36.36	29.9	66.3	Fundamental frequency
Vertical	1950.0	33.85	29.9	63.8	
Vertical	1969.8	39.02	29.9	68.9	
Vertical	1989.8	35.48	29.9	65.4	

The field strength is calculate by adding the correction factor to the measured level to obtain the corrected level. A sample calculation is as follows :

$$\text{Correction Factor}_{(dB)} = \text{Cable Losses}_{(dB)} + \text{Antenna Factor}_{(dB)} - \text{pre-amplifier gain}_{(dB)}$$

$$\text{Corrected Level}_{(dB\mu V/m)} = \text{Measured Level}_{(dB\mu V/m)} + \text{Correction Factor}_{(dB)}$$

No spurious emissions were found with a level upper to noise level in 100 kHz bandwidth (17 dBμV) from 1 GHz to 20 GHz.

No radiated emissions were found during the tests and thus the substitution method was not performed.

This confidential document is the property of NORTEL MATRA CELLULAR and may not be copied or circulated without permission
Ce document confidentiel est la propriété de NORTEL MATRA CELLULAR et ne peut être reproduit ou communiqué sans autorisation

4.7.3. TEST PROCEDURE

The equipment was configured as shown in figure below.

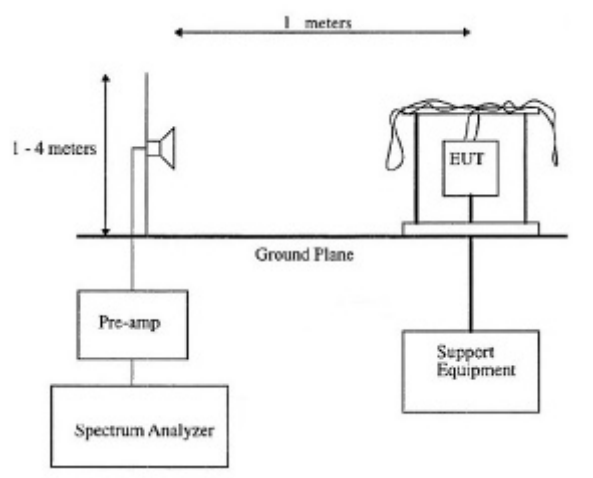

The BTS was configured to transmit at maximum power (static level 0). Measurements were made according to the procedures outline in ANSI C63.4. The emissions were investigated up to the tenth harmonic of the fundamental emission (20 GHz). The measured level of the emissions was recorded and compared to the limit.

The reference level for spurious radiation was taken with reference to an ideal dipole antenna excited by the rated output power according to the following relationship :

$$E\left(\frac{V}{M}\right) = \frac{1}{R(m)} * \sqrt{30 * P_t * G}$$

Where,

- E = Field Strength in Volts/meter,
- R = Measurement distance in meters,
- P_t = Transmitter Rated Power in Watts (1.58 Watts),
- G = Gain of Ideal Dipole (linear)

Therefore :

$$E\left(\frac{V}{M}\right) = \sqrt{30 * 1.58 * 1.64}$$

$$E = 8.82 \text{ V/m} = 138.9 \text{ dB}\mu\text{V/m}$$

The spurious emissions must be attenuated by at least $43 + 10 * \text{Log}(1.58) = 45 \text{ dB}$.

Therefore the field strength limit at 1 meters is :

$$E = 138.91 \text{ dB}\mu\text{V/m} - 45 \text{ dB} = 93.9 \text{ dB}\mu\text{V/m}$$

4.8. MEASUREMENT EQUIPMENT LIST

Table 5 is a list of all of the measurement equipment used in this report.

Table 5 : Measurement Equipment List

Equipment Description	Manufacturer	Model No.	Serial No.	V/A date
Network Analyzer	HP	8719D	521768	12/03
Power Meter	Giga-tronics	8542C	519565	02/03
CW Power Sensor	Giga-tronics	80401A	522394	02/03
Spectrum Analyzer	Rohde & Schwarz	FSEM	517751	03/02
Signal Generator	HP	HP 8657 B	509093	03/02
Programmable source DC	LAMBDA	Model LLS9060	ELC08493	03/03
Programmable source DC	LAMBDA	Model LLS9060	500222	03/02
30 dB attenuator	HP	8498A	519471	
20 dB Attenuator	Radiall	R417020128	-	
Notch Filter	Wainwright	SN4 WRCD 1989.8		

*This confidential document is the property of NORTEL MATRA CELLULAR and may not be copied or circulated without permission
Ce document confidentiel est la propriété de NORTEL MATRA CELLULAR et ne peut être reproduit ou communiqué sans autorisation*

5. EXHIBIT 2 : UPDATED EQUIPMENT LIST

Description	Hardware code	Comment
GSM 1900 Base Cabinet	NT0110DA	
PLDRX	NT015013	Logical board
GSM 1900 pRDRX	NT015041	Radio board
GSM 1900 Low Power Amplifier Hybrid	NT015460	PA module
GSM 1900 LNA-Duplexer	NT015503	
PPCM T1	NT014311	
PSL	NT014011	Power supply board

*This confidential document is the property of NORTEL MATRA CELLULAR and may not be copied or circulated without permission
Ce document confidentiel est la propriété de NORTEL MATRA CELLULAR et ne peut être reproduit ou communiqué sans autorisation*

- 6. EXHIBIT 3 : SCHEMATICS**
- 6.1. ECELL ASSEMBLY**
AD010AA.
- 6.2. PRDRX (RADIO BOARD)**
CS 015041
- 6.3. PLDRX (LOGIC BOARD)**
CS 015013
- 6.4. LPA HYBRID COUPLER ASSEMBLY**
NT015460
- 6.5. LNA DIPLEXER ASSEMBLY**
NT015503
- 6.6. PPCM BOARD**
CS 014311.
- 6.7. PPCM BOARD**
CS 014011

*This confidential document is the property of NORTEL MATRA CELLULAR and may not be copied or circulated without permission
Ce document confidentiel est la propriété de NORTEL MATRA CELLULAR et ne peut être reproduit ou communiqué sans autorisation*

⌘ **END OF DOCUMENT** ⌘

*This confidential document is the property of NORTEL MATRA CELLULAR and may not be copied or circulated without permission
Ce document confidentiel est la propriété de NORTEL MATRA CELLULAR et ne peut être reproduit ou communiqué sans autorisation*

ECELL BTS GSM1900: FCC Part 24 Certification Filing for Nortel AB6ECELL :

exhibits document

Page 38/38

PCS/BTS/DJD/0751

01.01 / EN

10/03/02