



L C I E

Radio Test Report in extreme conditions for the introduction of RICAM and GSM 850MHz band in GSM 6000 BTS Outdoor AC version (FCC)

Reference: 60056545-557309-R-TR-6oac-FCC

Version: A

Status: Approved

Date: 02/May/2007

Customer: NORTEL NETWORKS
Parc d'Activités de Magny-Châteaufort
78928 Yvelines Cedex 09

Product: GSM 6000 BTS

Author: Marc CANCOUËT

Technical Manager: Didier PRADON

P. O.

This document shall not be reproduced, except in full, without the written approval of the LCIE.
This document contains results related only to the items tested. It does not imply the conformity of the whole production to the items tested.

PUBLICATION HISTORY

VERSION	DATE	AUTHOR	MODIFICATION
A	2-May-07	M.CANCOUËT	Creation of document

CONTENTS

CONTENTS	3
1. INTRODUCTION	4
2. RELATED DOCUMENTS	5
3. RELATED DOCUMENTS	5
3.1. APPLICABLE STANDARDS	5
3.2. REFERENCE DOCUMENTS	5
4. IDENTIFICATION OF EQUIPMENT UNDER TEST	6
4.1. GSM 6000 OUTDOOR BTS	6
5. TESTS RESULTS	8
5.1. TEST PROCEDURE	8
5.2. SOFTWARE CONFIGURATION	8
5.3. TEST RESULTS GSM 6000 OUTDOOR BTS	9
6. CONCLUSION	13
7. MEASUREMENT EQUIPMENT LIST	13
8. ABBREVIATIONS AND DEFINITIONS	14
8.1. ABBREVIATIONS	14
8.2. DEFINITIONS	15

1. INTRODUCTION

The objective of this document is to present the tests report of the FCC Radio qualification in extreme temperature on the GSM 6000 Outdoor BTS AC version for the qualification of GSM 850 MHz and RICAM introduction on BTS 6000 Cabinets.

For North America, applicable standard for Radio of GSM 850 MHz Base stations are the FCC Part 22 /RS132.

This document is addressed to Nortel Product Integrity team.

2. RELATED DOCUMENTS

3. RELATED DOCUMENTS

3.1. APPLICABLE STANDARDS

[A1]	CFR 47 Part 2	Code of Federal Regulations - Part 2 - Frequency Allocations and Radio Treaty Matters. General Rules and Regulations. Date : June 1996.
[A2]	CFR 47 Part 22	Code of Federal Regulations - Part 24 - PERSONAL COMMUNICATIONS SERVICES.
[A3]	RSS 132	Industry Canada - Personal Communication Services in the 2GHz band.

3.2. REFERENCE DOCUMENTS

[R1]	PE/BTS/DPL/021882	GSM 6000 BTS Project Qualification Plan For GSM850&PCS1900 Cabinet and RICAM Introduction for CE & FCC Marking
[R2]	PE/BTS/DPL/022107	Test Plan for Dual Band GSM 850 & PCS1900 BTS 6000 Cabinets Radio Qualification (FCC & 3GPP)
[R3]	PE/BTS/DJD/022074 01.01/EN	GSM 6000 outdoor BTS 850MHz hardware delivery notice

4. IDENTIFICATION OF EQUIPMENT UNDER TEST

4.1. GSM 6000 OUTDOOR BTS

This document applies to:

Product: GSM 6000 OUTDOOR BTS (AC Version)
Manufacturer: NORTEL NETWORKS
Frequencies: GSM 850 MHz
Configuration: -
Option: -

AVLM Recipient: LCIE	Date of delivery: 18/APR/2007
Product: GSM 6000 Outdoor BTS	
Article delivered: AC version of GSM 6000 Outdoor BTS	Article code: NTQ610FA D1
Section transmitting: 8U00	Designer name: Chenet Stéphane
Cabinet Serial Number: NNTMGT004KG2 / 434137	
Documents related to the Hardware Design Specifications - PE/BTS/DD/016672 V01.05/EN BTS 6000 Product Specification	
Documents dealing with specifications:	
Issues fixed on the cabinet:	
Missing Equipment:	
Software compatibility: Modules software version : - Load BTS : v15f1e04 / CDI118000 > ICM/ABM : v15f104 / CDI117970 > RM : v15e403 / CDI117006 PI software tools : - WINTMI: v03d306 - TIL COAM: v15e403 - TIL Alarm: v15e402 - WINTOOL: v04b4e10	

The delivery includes :

ARTICLE	PEC code	Release	Serial number	Comment
CAB: PRECA	NTQ610FA	D1	NNTMGT004KG2	
UCPS Rectifier 1.4KW	NTN070BF	04	ATSNZH152588	ARTESYN Rectifier CR
UCPS Rectifier 1.4KW	NTN070BF	04	ATSNZH152431	ARTESYN Rectifier CR
UCPS CCU UMTS/GSM	NTUM44AF	01	ATSNZH085686	
DDU	NTN066AA	D1	ATSNZH096636	
ADU	NTQ666CA	01	ATSNZH116616	
SAFT Battery	NTQ675AA	0D	07445LD00010	
CRICO	NTQ620CA	D1	NNTMGT004JQT	
CECU FAN TRAY AC	NTQ675JG	01	NNTMGT004YU7	
CECU Control Board	NTQ629AA	01	N/A	Control board without SN
RICAM	NTN024AA	D1 MIR 1 +	FLAMESAREMAGIX	ICM 0 : IP → 47.164.182.160 ICM 0 : IP → 47.164.182.161 IABM 0 : IP → 47.164.182.162
HPRM 3T 850	NTN050JA	D1	CDN200651003	IP 47.164.182.178 with new PSU CR NTN058AM 04 / ATSNZH155432
HPRM 3T 850	NTN050JA	D1	CDN200651010	IP 47.164.182.179 with new PSU CR NTN058AM 04 / ATSNZH155424
DDM 850 W/VSWR W/HYBRIDS ROHS	NTN063HM	D2	FICT03002119	
DDM 850 W/VSWR W/HYBRIDS ROHS	NTN063HM	D2	FICT0300212D	
DDM 850 W/VSWR W/HYBRIDS ROHS	NTN063HM	D1	FICT0200204F	
CALPRO2	NTQ675CA	D1	NNTMGT004MHX	
CUSER-ICO	NTQ650AA	D1	NNTMGT004L6Z	

Remark: The exact configuration used during tests is described in § 5.3

5. TESTS RESULTS

5.1. TEST PROCEDURE

The BTS must operate under the following external extreme temperatures:

- BTS 6000 Outdoor : - 33°C / + 50 °C

Frequency stability are performed under following extreme conditions:

for Indoor 6000 BTS

Temperature from -33°C to +50°C at intervals of 10 degrees.

With AC power supply variations: 187 VAC, 264 VAC

Modules GSM HPRM 850MHz run with nominal power regulation at maximum power (60W) in GMSK modulation. The HPRM were configured to transmit at maximum power (Static level 0). A period of at least one hour was allowed prior to measurement to ensure that all the components of the oscillator circuit was stabilized at each temperature.

The equipment was configured as shown in Schematic below.

Test configuration for Frequency Stability & Power

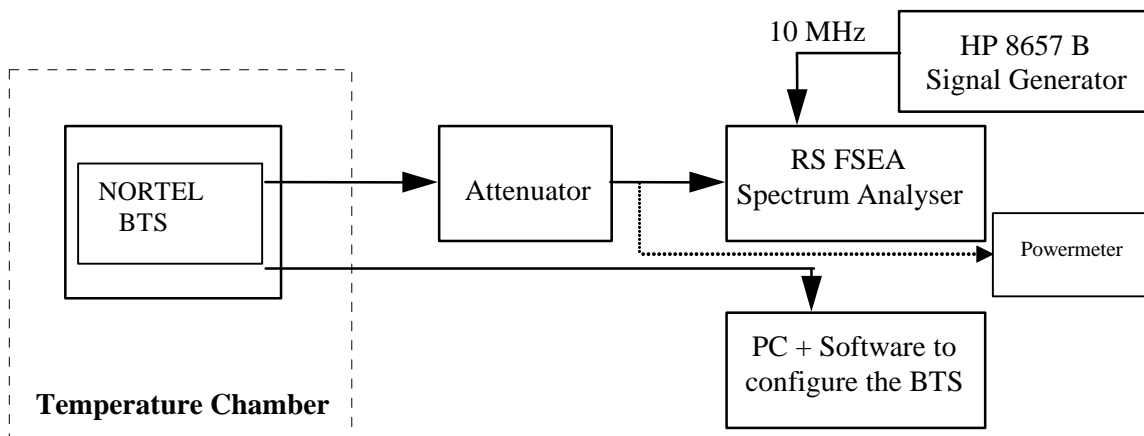

5.2. SOFTWARE CONFIGURATION

BTS type	GSM 6000 Outdoor BTS
BTS	v15f1e04 / CDI118000
ICM/ABM/RICAM	v15f104 / CDI117970
RM	v15e403 / CDI117006
WinTMI	v03d306
Til COAM	v15e403
Til Alarm	v15e402
Win TOOL	v04b4e10

5.3. TEST RESULTS GSM 6000 OUTDOOR BTS

5.3.1 BTS CONFIGURATION

GSM 6000 OUTDOOR BTS (AC version)

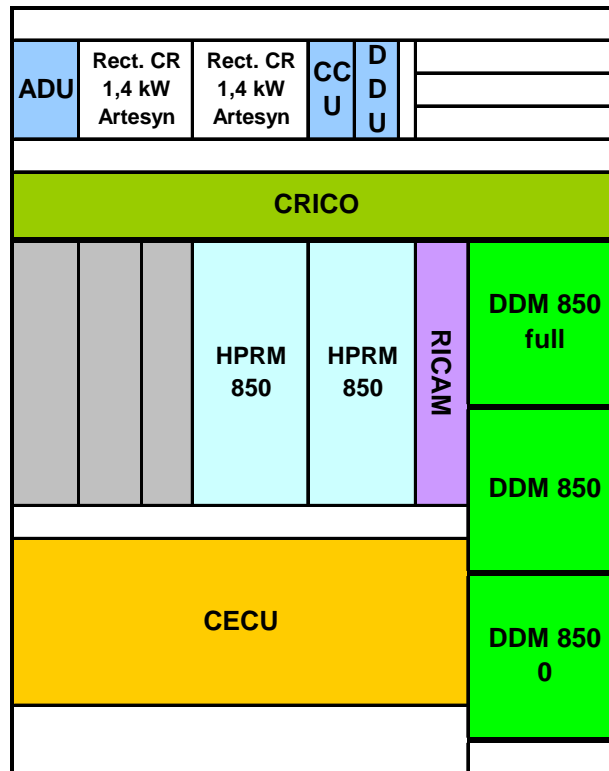

Tested modules

	ARTICLE	PEC code	Release	Serial number
HPRM 1	HPRM 3T 850	NTN050JA	D1	CDN200651010
DDM 1 850	DDM 850 W/VSWR W/HYBRIDS ROHS	NTN063HM	D2	FICT03002119

5.3.1.1 FREQUENCY STABILITY IN BTS 6000 OUTDOOR CONFIGURATION – CHANNEL 128

Table below shows the Frequency Stability power for channel 128 (F= 869,2 MHz) in BTS 6000 OUTDOOR (TX0) configuration under extreme conditions.

Temperature (°C)	Maximum Carrier Frequency Deviation (Hz)	
	82% Nominal Supply voltage 187 V AC	115% Nominal Supply voltage 264 V AC
-33	9.88	12.07
-20	13.61	10.56
-10	12.8	11.59
0	11.7	10.83
10	9.97	12.55
20	9.61	7.96
30	11.9	9.53
40	8.02	7.2
50	8.96	8.73

The maximum frequency deviation allowed is 0.05 ppm (+/- 43 Hz).. The maximum deviation measured (13.61Hz) is more than sufficient to ensure that the fundamental emission stays within the authorized frequency block.

5.3.1.2 FREQUENCY STABILITY IN BTS 6000 OUTDOOR CONFIGURATION – CHANNEL 190

Table below shows the Frequency Stability power for channel 190 (F= 881,6 MHz) in BTS 6000 OUTDOOR (TX1) configuration under extreme conditions.

Temperature (°C)	Maximum Carrier Frequency Deviation (Hz)	
	82% Nominal Supply voltage 187 V AC	115% Nominal Supply voltage 264 V AC
-33	10.53	8.33
-20	-8.88	-9.05
-10	11	-8.33
0	-8.23	-9.3
10	-7.81	8.79
20	9.5	-8.44
30	9.23	10.04
40	-9.2	12.44
50	-5.39	-9.78

The maximum frequency deviation allowed is 0.05 ppm (+/- 43 Hz).. The maximum deviation measured (12.44Hz) is more than sufficient to ensure that the fundamental emission stays within the authorized frequency block.

5.3.1.3 FREQUENCY STABILITY IN BTS 6000 OUTDOOR CONFIGURATION – CHANNEL 251

Table below shows the Frequency Stability power for channel 251 (F= 893,8 MHz) in BTS 6000 OUTDOOR (TX2) configuration under extreme conditions.

Temperature (°C)	Maximum Carrier Frequency Deviation (Hz)	
	82% Nominal Supply voltage 187 V AC	115% Nominal Supply voltage 264 V AC
-33	12.2	6.97
-20	8.01	-11.3
-10	10.86	11.03
0	8.86	10.22
10	9.08	9.7
20	7.69	8.46
30	8.59	9.84
40	8	8.89
50	-8.28	-10.84

The maximum frequency deviation allowed is 0.05 ppm (+/- 43 Hz).. The maximum deviation measured (12.2Hz) is more than sufficient to ensure that the fundamental emission stays within the authorized frequency block.

5.3.1.4 MEAN RF POWER IN BTS 6000 OUTDOOR CONFIGURATION – CHANNEL 128

Table below shows the Mean RF power for channel 128 (F= 869,2 MHz) in BTS 6000 OUTDOOR (TX0) configuration under extreme conditions.

Measurements are realized at antenna output for H2 Duplexer configuration.

Specification for H2 Duplexer configuration in GMSK :

The power must be ≥ 41 dBm and ≥ 45 dBm.

Temperature (°C)	Mean RF Power (dBm)		Sanction
	82% Nominal Supply voltage 187 V AC	115% Nominal Supply voltage 264 V AC	
-33	43.18	43.19	PASS
-20	43.2	43.2	PASS
-10	43.19	43.18	PASS
0	43.17	43.19	PASS
10	43.18	43.14	PASS
20	43.19	43.2	PASS
30	43.18	43.17	PASS
40	43.2	42.21	PASS
50	43.16	43.18	PASS

5.3.1.5 MEAN RF POWER IN BTS 6000 OUTDOOR CONFIGURATION – CHANNEL 190

Table below shows the Mean RF power for channel 190 (F= 881,6 MHz) in BTS 6000 OUTDOOR (TX1) configuration under extreme conditions.

Measurements are realized at antenna output for H2 Duplexer configuration.

Specification for H2 Duplexer configuration in GMSK :

The power must be ≥ 41 dBm and ≥ 45 dBm.

Temperature (°C)	Mean RF Power (dBm)		
	82% Nominal Supply voltage 187 V AC	115% Nominal Supply voltage 264 V AC	Sanction
-33	43.28	43.27	PASS
-20	43.2	43.22	PASS
-10	43.21	43.22	PASS
0	43.23	43.23	PASS
10	43.26	43.26	PASS
20	43.21	43.22	PASS
30	43.23	43.23	PASS
40	43.24	43.22	PASS
50	43.22	43.21	PASS

5.3.1.6 MEAN RF POWER IN BTS 6000 OUTDOOR CONFIGURATION – CHANNEL 251

Table below shows the Mean RF power for channel 251 (F= 893,8 MHz) in BTS 6000 OUTDOOR (TX2) configuration under extreme conditions.

Measurements are realized at antenna output for H2 Duplexer configuration.

Specification for H2 Duplexer configuration in GMSK :

The power must be ≥ 41 dBm and ≥ 45 dBm.

Temperature (°C)	Mean RF Power (dBm)		
	82% Nominal Supply voltage 187 V AC	115% Nominal Supply voltage 264 V AC	Sanction
-33	43.24	43.25	PASS
-20	43.15	43.15	PASS
-10	43.25	43.25	PASS
0	43.24	43.23	PASS
10	43.26	43.26	PASS
20	43.25	43.22	PASS
30	43.25	43.27	PASS
40	43.27	43.27	PASS
50	43.24	43.22	PASS

6. CONCLUSION

The GSM 6000 Outdoor BTS (AC version) equipped with GSM 850MHz HPRM 850 as described in this document complies with the FCC & IC radio requirements in extreme temperature.

7. MEASUREMENT EQUIPMENT LIST

Equipment description	Manufacturer	Model	Serial No.	LCIE No.
Spectrum analyser	R&S	FSEA	842655/02	A4060015
Spectrum analyser	Agilent	VSA	Nortel N° 571313	-
MIC analyseur	W&G	PA20	Y0075	A4040009
Signal generator	HP	8657B	3520U06355	A5442020
Signal generator	HP	8648A	3430V00370	-
Power Meter	Giga-tronics	8542C	1832488	A1503009
RF Probe	Giga-tronics	80401A	18330224	A1509027
40 dB 60 W attenuator	Diconex		02077	-
Temperature chambre	CLIMAT SAPRATIN	PV140C80F60H R	SV025496S	D1025025

8. ABBREVIATIONS AND DEFINITIONS

8.1. ABBREVIATIONS

ARFCN	Absolute Radio Frequency Channel Number
BCCH	Broadcast Control Channel
BER	Bit Error Rate
BTS	Base Transceiver Station
C	Celsius
CPC	Common Product Code
DB	Decibel
dBc	Decibel referenced to the carrier level
dBm	Decibel ref 1milliwatt
DOA	Dead On Arrival
DRX	Driver Receiver Board
DTX	Discontinuous Transmitter
EDGE	Enhanced Data for GSM Evolution
EFT	Electrical Fast Transient
EMC	Electro-Magnetic-Compatibility
EMI	Electro-Magnetic-Interference
ESD	Electrical Static Discharge
ESS	Environmental Screaming Test
FH Bus	Transmission bus between FP and TX
FMECA	Failures Mode Effect Critically Analysis
FP	Frame Processor
GMSK	Gaussian Minimum Shift Keying
GSM	Global System for Mobile Communications
HALT	Highly Accelerated Life Test
IF	Intermediate Frequency
LISN	Line Impedance Stabilization Networks
LNA	Low Noise Amplifier
MTBF	Mean Time Between Failure
N.A.	Not Applicable
NER	Nominal Error Rate
NFF	No Fault Found
NFH	No Frequency Hopping
NN	Nortel Networks
OEM	Original Equipment Manufacturer
PA	Power Amplifier

PAR	Peak to Average Ratio
PEC	Product Engineering Code
PMR	Peak to Minimum Ratio
PSU	Power Supply Unit
RBER	Residual Bit Error Rate
RF	Radio Frequency
RICAM	Redundant Interface Control Alarm Module
RMS	Root Mean Square
RX	Receiver
SFH	Slow Frequency Hopping
SPQL	Shipped Product Quality Level
SPR	Serial PEC Release
TBC	To Be Confirmed
TBD	To Be Defined
TCH	Traffic Channel
TDMA	Time Domain Multiple Access
TRX	Transmitter – Receiver
TS	Time slot
TX	Transmitter
UNL	Unit nominal Level
URG	Unit Reference Gain
UUT	Unit Under Test
VAD	Voice Activity Detection
VSWR	Voltage Standing Wave Ratio
VVA	Variable Voltage Attenuator

8.2. DEFINITIONS

None

END OF DOCUMENT