



LCIE

EMC Test report for the introduction of GSM RM2 1900MHz band in GSM 6000 Outdoor BTS (FCC)

Reference: 81818-571635-C-TR-6-FCC

Version: A

Status: Approved

Date: 09/July/2008

Customer: NORTEL NETWORKS
Parc d'Activités de Magny-Châteaufort
78928 Yvelines Cedex 09

Product: GSM 6000 BTS 1900 MHz

Author: Vivien GODET

Technical Manager: Didier PRADON

10/07/2008

*This document shall not be reproduced, except in full, without the written approval of the LCIE.
This document contains results related only to the items tested. It does not imply the conformity of the whole production to the items tested.*



PUBLICATION HISTORY

VERSION	DATE	AUTHOR	MODIFICATION
A	09-July-08	V. GODET	Creation of document



CONTENTS

1.	INTRODUCTION	4
2.	RELATED DOCUMENTS	5
2.1.	APPLICABLE STANDARDS	5
2.2.	REFERENCE DOCUMENTS	5
3.	IDENTIFICATION OF EQUIPMENT UNDER TEST	6
4.	TESTS RESULTS	12
4.1.	EMISSIONS TESTS	12
4.1.1	Test configuration	12
4.1.2	Matrix Results	15
4.1.3	Conducted emission curve on GSM 6000 Outdoor DC	16
5.	CONCLUSION	18
6.	ABBREVIATIONS AND DEFINITIONS	19
6.1.	ABBREVIATIONS	19
6.2.	DEFINITIONS	20



1. INTRODUCTION

This document presents the EMC tests report for the FCC EMC qualification of GSM 6000 BTS in the 1900 MHz frequency band with new RM2 1900MHz modules.

For the qualification of GSM 6000 BTS in the 1900MHz GSM band, a full EMC qualification has been done on GSM 6000 BTS Outdoor AC and a non regression conducted emission test has been done on GSM 6000 BTS Outdoor DC.

The introduction of the new RM2 1900MHz module in GSM 6000 BTS Indoor cabinet AC version is done by similarity with GSM 6000 BTS Outdoor cabinet AC version. Those both versions are identical except door, enclosure and gaskets. Gaskets of Outdoor version are less efficient than Indoor version gaskets concerning EMC aspect, so test results of GSM 6000 BTS Outdoor cabinet AC version are representative for GSM 6000 BTS Indoor cabinet AC version.

For North America, applicable standard for EMC Base stations are the FCC part 15[Part 15.107 and 15.109 (subpart B)]/ICES 003 Class B and the FCC Part 24/RS133 [Part 24.238 (subpart H)]/RS133.

We covered also the FCC Part 15 [Part 15.207 and 15.209 in frequency range 30MHz to 18 GHz (subpart C)] class B.

The tests were performed at LCIE Ecuelles (FCC registration number: 888863 – Industry Canada number: IC62311)

The following table gives some information of the EUT :

Product Name	GSM 6000 Outdoor BTS
Manufacturer	NORTEL
Serial Number	-
Alimentation of the EUT	AC or DC



2. RELATED DOCUMENTS

2.1. APPLICABLE STANDARDS

[A1]	CFR 47 Part 2	Code of Federal Regulations - Part 2 - Frequency Allocations and Radio Treaty Matters. General Rules and Regulations. Date : June 1996.
[A2]	47 CFR Part 15 08/20/02	FCC Rules for Radio Frequency Devices, Title 47 of the Code of Federal Regulations – Radio frequency devices – dated 08/20/02
[A3]	CFR 47 Part 24	Code of Federal Regulations - Part 24 - Personal Communications Services.
[A4]	IC ES 003 (NMB 003)	Industry Canada - Digital apparatus
[A5]	RSS 133	Industry Canada – 2 GHz Personal Communications Services.

2.2. REFERENCE DOCUMENTS

[R1]	PE/BTS/DPL/023431	GSM18000 & 9000 & 6000 BTS (HIPP) Project Qualification Plan for RM2 PCS1900 introduction
[R2]	81818-571635-TP-18-FCC	EMC Test plan for the introduction of GSM RM2 1900MHz (FCC)
[R3]	PE/BTS/DJD/020820/V03	GSM 6000 outdoor BTS 1900MHz hardware delivery notice (V03.01)
[R4]	PE/BTS/DJD/020820/V04	GSM 6000 outdoor BTS 1900MHz hardware delivery notice (V04.01)



3. IDENTIFICATION OF EQUIPMENT UNDER TEST

This document applies to:

Product: GSM 6000 BTS
OUTDOOR AC
Manufacturer: NORTEL
Frequencies: 1900 MHz
Configuration: AC
Option: CALPRO2 & CPRIPRO2

AVLM Recipient: LCIE	Date of delivery: 13/JUNE/2008
Product: GSM 6000 Outdoor BTS	
Article delivered: AC version of GSM 6000 Outdoor BTS	Article code: NTQ610FA 01
Section transmitting: 8Z60	Designer name: Chenet Stéphane
Cabinet Serial Number: NNTMGVC10024	
Documents related to the Hardware Design Specifications – PE/BTS/DD/016672 V01.05/EN BTS 6000 Product Specification	
Documents dealing with specifications:	
Issues fixed on the cabinet:	
Missing Equipment:	
Software compatibility: Modules software version : – Load BTS : / – ICM/ABM : CDI120795 – RM : CDI121233 PI software tools : – WINTMI: v03d306 – TIL COAM: v16a304 – TIL Alarm: v16a301 – WINTOOL: v05a2_e16.0	



The delivery includes :

ARTICLE	PEC code	Release	Serial number	Comment
CAB: PRECA	NTQ610FA	01	NNTMGVC10024	
UCPS CCU UMTS/GSM	NTUM44AF	01	ATSNZH117028	
DDU	NTN066AA	D1	ATSNZH122771	
ADU	NTQ666CA	D1	ATSNZH121759	
CRICO	NTQ620CA	01	NNTMGVC30024	
CECU	NTQ675JG	01	NNTMGVC20024	
CECU Control Board	NTQ629AA	01	NNTMLA07G23D	
RICAM	NTN024AA	0D2	FANTASTIX	MIR 2.5 IP ICM0 : 47.164.182.180
RM2 1900 50/30	NTN050PP	D1	NNTM7880Y9QV	
RM2 1900 50/30	NTN050PP	D1	NNTM7880Y9QY	
DDM 1900 W/VSWR W/ HYBRIDS	NTN063AA	04	FICT03000PEX	
DDM 1900 W/VSWR W/HYBRIDS	NTN063AA	03	FICT03000N94	
DDM 1900 W/VSWR W/ HYBRIDS	NTN063AA	D1	FICT020000JH	
CALPRO2	NTQ675CA	D1	NNTMGT004MHZ	
CUSERICO	NTQ650AA	D1	NNTMGT004L67	
Battery SAFT	NTQ675AA	01	07445L000015	
CPRI PRO2	NTQ675SA	02	NNTM7880WTAV	
RECTIFIER, 1400 W	NTN070BF	01	ATSNZH085318	
RECTIFIER, 1400 W	NTN070BF	01	ATSNZH085344	

**Additional delivery:**

ARTICLE	PEC code	Release	Serial number	Comment
Isolator box for CECU debug	N/A	N/A	N/A	
External alarm cable				
ABIS external cable				

Tests performed:

- MIC BER in T1
- Inventory test.
- DDM Alarms & Inventory interface.
- Dale & Dali.
- TX sequence with factory test bench on each RM2 1900 MHz
- RX sequence with factory test bench on each RM2 1900 MHz

Functional limits:**- Hardware Limitations :**

None

- Software Limitations :

None

Documents related to the Hardware Test Specifications

Reference of the test specifications documents:

- PE/BTS/DJD/018118 V01.01/EN Hardware integration test specification for BTS 6000

Documents related to the Hardware Test Report

Reference of the test reports documents:

- PE/BTS/DJD/023736 V01.01/EN Hardware integration tests report for GSM1900 RM2 introduction



Product: GSM 6000 BTS OUTDOOR DC
Manufacturer: NORTEL
Frequencies: 1900 MHz

Configuration: DC

Option: CALPRO2

AVLM Recipient: LCIE	Date of delivery: 13/JUN/2008
Product: GSM 6000 Outdoor BTS	
Article delivered: DC version of GSM 6000 Outdoor BTS	Article code: NTQ610AA 01
Section transmitting: 8Z60	Designer name: Chenet Stéphane
Cabinet Serial Number: NNTMGVE10002	
Documents related to the Hardware Design Specifications – PE/BTS/DD/016672 V01.05/EN BTS 6000 Product Specification	
Documents dealing with specifications:	
Issues fixed on the cabinet:	
Missing Equipment:	
Software compatibility: Modules software version : – Load BTS : / – ICM/ABM : CDI120795 – RM : CDI121233 PI software tools : – WINTMI: v03d306 – TIL COAM: v16a304 – TIL Alarm: v16a301 – WINTOOL: v05a2_e16.0	



The delivery includes :

ARTICLE	PEC code	Release	Serial number	Comment
CAB: PRECA	NTQ610AA	01	NNTMGVE10002	
UCPS CCU UMTS/GSM	NTUM44AF	01	ATSNZH174210	
DDU	NTN066AA	02	ATSNZH173907	
DCU	NTQ666BA	01	ATSNZH125867	
CRICO	NTQ620CA	01	NNTMGVC30084	
CECU	NTQ675JA	03	NNTMGVD21055	
CECU Control Board	NTQ629AA	01	NNTMLA07G24Q	
ICAM	NTN024BA	V1	NNTMGWF40007	
DDM 1900 W/O VSWR W/HYBRIDS	NTN063AM	01	FICT0300021V	
DDM 1900 W/VSWR W/O HYBRIDS	NTN063BA	04	FICT03001E81	
DDM 1900 W/VSWR W/O HYBRIDS	NTN063BA	04	FICT03001F5X	
CALPRO2	NTQ675CA	D1	NNTMGT004MHX	
CUSERICO	NTQ650AA	01	NNTM78901H2M	

Additional delivery:

ARTICLE	PEC code	Release	Serial number	Comment
External alarm cable				
ABIS external cable				

Tests performed:

The following features have been tested:

- MIC BER in T1
- Inventory test.
- DDM Alarms & Inventory interface.
- Dale & Dali.

Functional limits:

- **Hardware Limitations :**

None

- **Software Limitations :**

None

Documents related to the Hardware Test Specifications

Reference of the test specifications documents:

- PE/BTS/DJD/018118 V01.01/EN Hardware integration test specification for BTS 6000

Documents related to the Hardware Test Report

Reference of the test reports documents:

- PE/BTS/DJD/023736 V01.01/EN Hardware integration tests report for GSM1900 RM2 introduction

4. TESTS RESULTS

4.1. EMISSIONS TESTS

4.1.1 TEST CONFIGURATION

The BTS is configured as close to normal intended use. The GSM 6000 BTS 1900 MHz is configured to transmit on all RF channels at Pmax on all the frequency band.

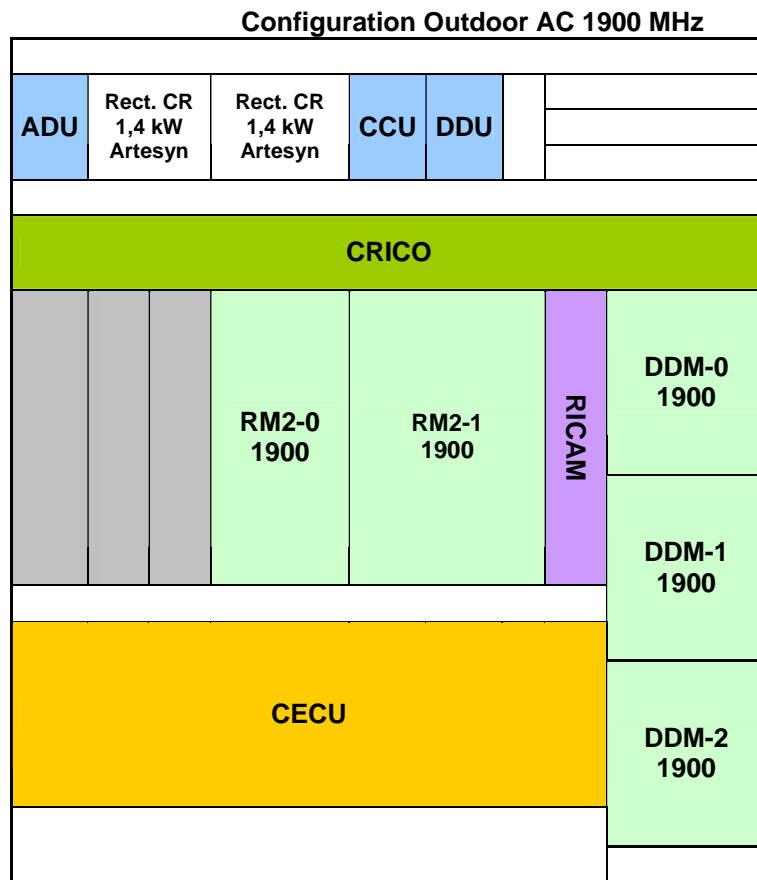



Configuration Outdoor DC 1900 MHz

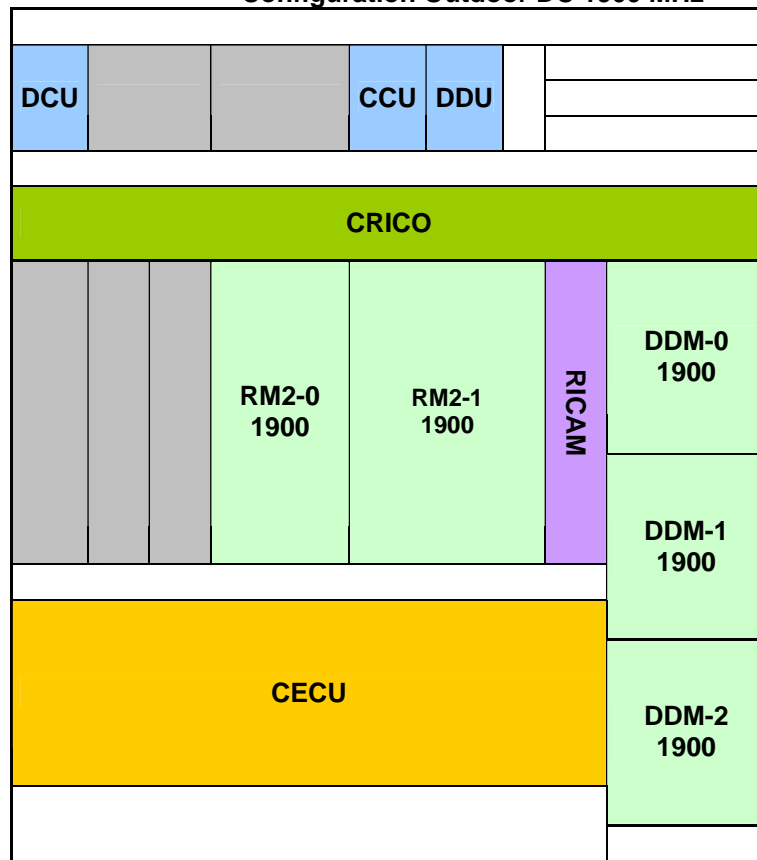

Frequencies configurations on RM2 PCS 1900MHz slot 0 and 1:

- TDMA 0: Channel C512
- TDMA 1: Channel C661
- TDMA 2: Channel C810

CALPRO2 is present during this EMC campaign.

The Abis cable of the BTS is looped back at the end and a PCM signal is transmitted on these cables.

The following ports of the BTS will be available and connected :

- Abis port (telecom port) : cable 16 meters 120Ω. This cable is looped in order to transmit TX signals on RX ones.
- GSM external Alarms ports: 1 cable is in open circuit.
- Radio port (signal port) : 4 RF cables RADIALL SHF9TD – DC-2GHz – Insertion loss < 5.5 dB at 2 GHz (15 meters). Attenuators and loads will also be used on RF links.
- AC or DC port : Lab cable (about 10 meters).

The hardware, software status and the functional limits are described in the document referenced [R2 & R4].

Figure N°1: Emissions testing configuration

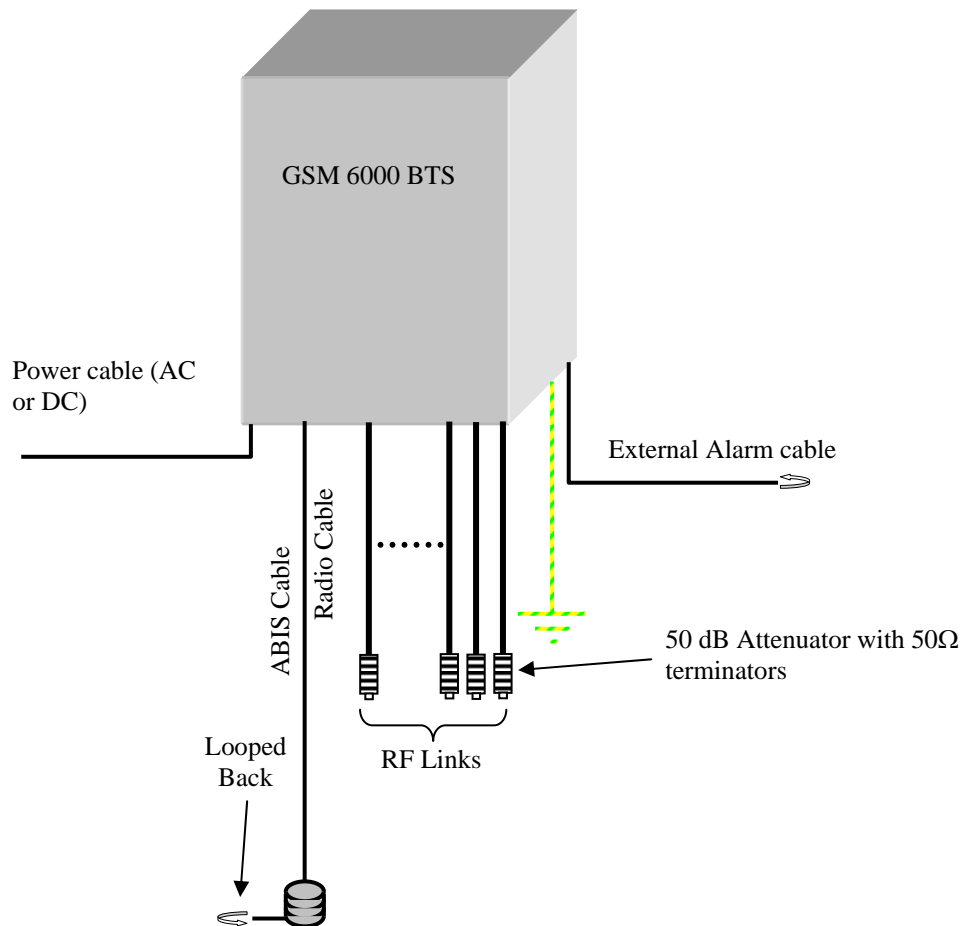



4.1.2 MATRIX RESULTS

This table presents the tests realized and the severity applied :

Configuration Outdoor AC 1900 MHz

Test	Compliance	Comments
Conducted Emissions on AC Port FCC Part15 §15.107 & §15.207 ICES003 (0.15 MHz to 30 MHz)	PASS	Split phase 240V – 60 Hz: Pass the FCC Part §15.107 & 15.207 Class B & ICES 003 with 6 dB margin QP / AVG.
Radiated Emissions FCC Part 15 § 15.109 & 15.209 ICES003 (30 MHz to 18 GHz)	PASS	Pass the FCC Part §15.109 & 15.209 (30MHz to 18 GHz) Class B with 8 dB margin & ICES 003 with 8 dB margin in worst case.
Radiated Emissions Spurious FCC Part 24 § 24.238 RSS133 (30 MHz to 20 GHz)	PASS	For 50 W, limit is 93.9 dBµV/m @ 1 m or 73.9 dBµV/m @ 10 m. No spurious (30dB margin)

Configuration Outdoor DC 1900 MHz

Test	Compliance	Comments
Conducted Emissions on DC Port FCC Part15 §15.107 & §15.207 ICES003 (0.15 MHz to 30 MHz)	PASS	For information only: DC -48 V: Pass the FCC Part §15.107 & 15.207 Class B with 3 dB margin QP / AVG.

Note: See Conducted Emission curve in Clause 4.1.3 for details.

4.1.3 CONDUCTED EMISSION CURVE ON GSM 6000 OUTDOOR DC

Conducted emission

-48V

Equipement: GSM 6000 Outdoor DC
 Manufacturer: NORTEL
 Operating Condition: -48Vdc cable
 Test Site: S75
 Operator: LRo
 Test Specification: MAXPeak + Avg
 Comment: Equiped with RM2 PCS 1900MHz
 Start of Test: 2008-07-10

SCAN TABLE: "EN 55022 Voltage"

Short Description:			EN 55022 Voltage			
Start Frequency	Stop Frequency	Step Width	Detector	Meas. Time	IF Bandw.	Transducer
150.0 kHz	30.0 MHz	5.0 kHz	MaxPeak QuasiPeak	100.0 ms	9 kHz	None

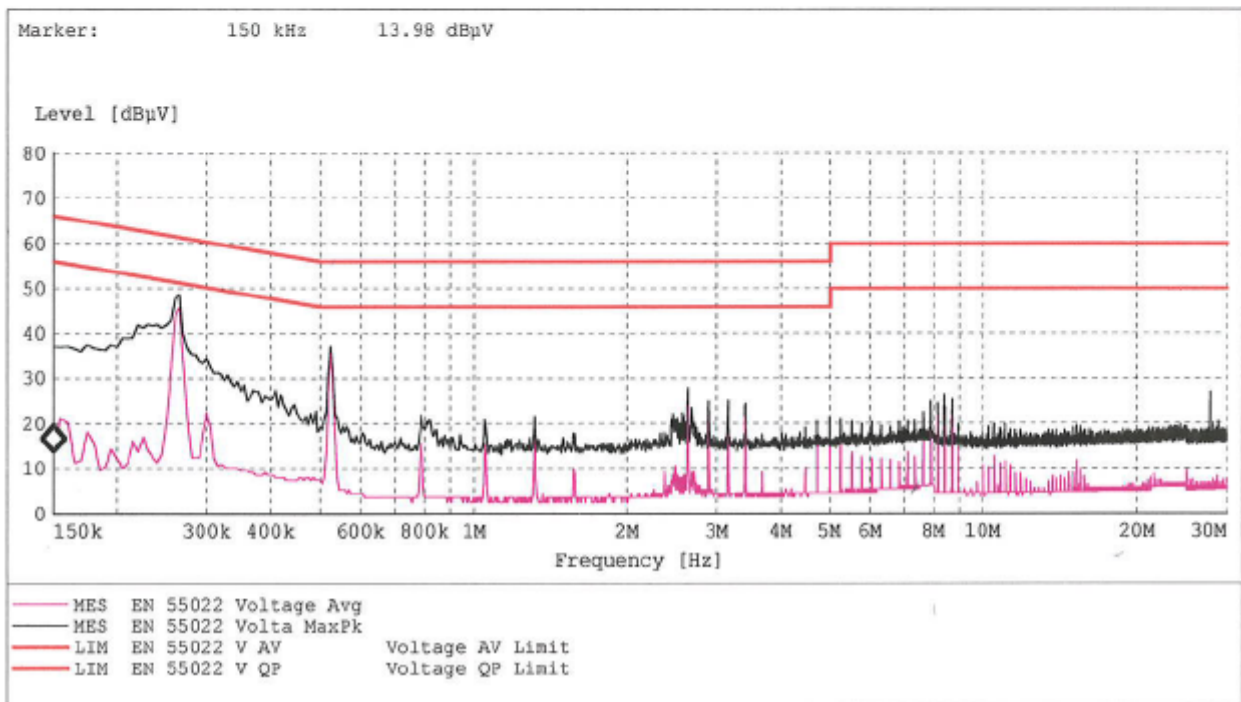



Conducted emission

0V

Equipment: GSM 6000 Outdoor DC
 Manufacturer: NORTEL
 Operating Condition: 0Vdc cable
 Test Site: S75
 Operator: LRo
 Test Specification: MAXPeak + Avg
 Comment: Equiped with RM2 PCS 1900MHz
 Start of Test: 2008-07-10

SCAN TABLE: "EN 55022 Voltage"

Short Description:	EN 55022 Voltage					
Start	Stop	Step	Detector	Meas. Time	IF Bandw.	Transducer
150.0 kHz	30.0 MHz	5.0 kHz	MaxPeak	100.0 ms	9 kHz	None
			QuasiPeak			

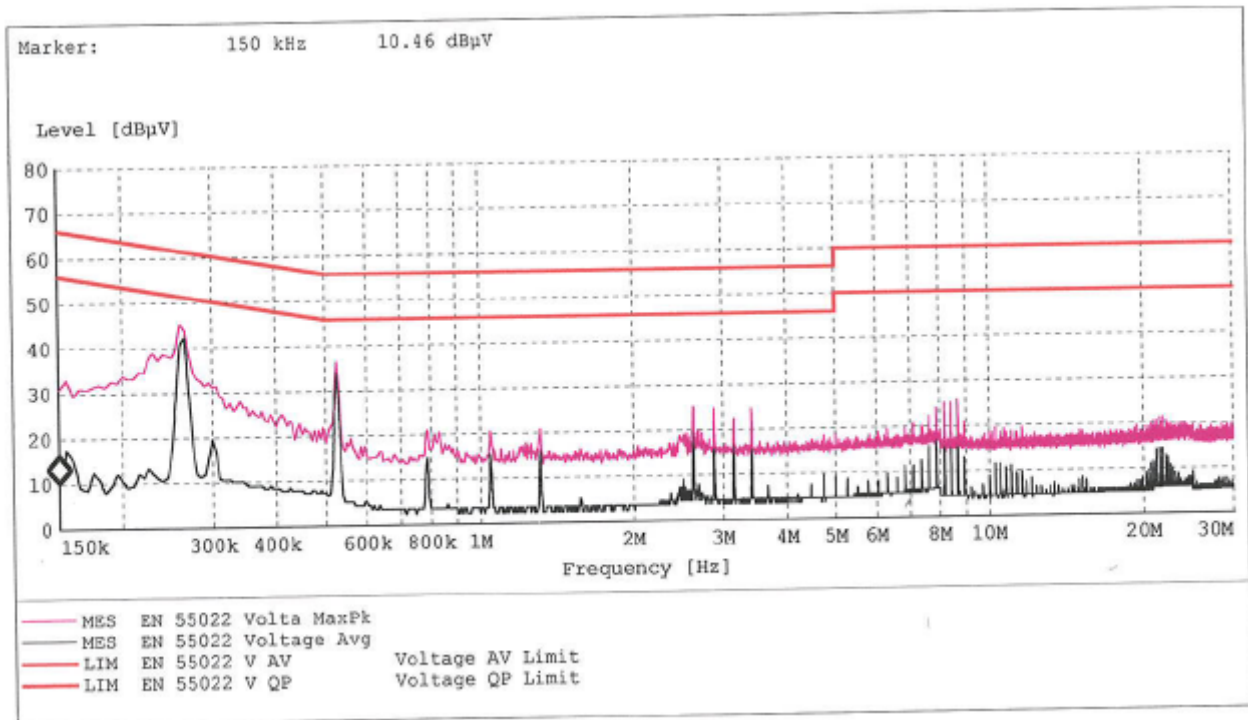



5. CONCLUSION

The GSM 6000 BTS Outdoor cabinet in AC version equipped with RM2 1900MHz, and GSM 6000 BTS Outdoor cabinet in DC version equipped with RM2 1900MHz as described in this document complies with the FCC part 15 [Part 15.107 and 15.207 (subpart B)]/ICES 003 Class B and the FCC Part 24 [Part 24.238]/RS133.

They comply also with the FCC Part 15 [Part 15.109 and 15.209 in frequency range 30MHz to 18 GHz (subpart C)] class B.

The introduction of the new RM2 1900MHz module in GSM 6000 BTS Indoor cabinet AC version is done by similarity with GSM 6000 BTS Outdoor cabinet AC version and by analysis of the EMC results obtained with GSM 6000 BTS Outdoor cabinet AC version. Therefore the GSM 6000 BTS Indoor cabinet in AC version equipped with RM2 1900MHz as described in this document comply with the FCC part 15 [Part 15.107 and 15.207 (subpart B)]/ICES 003 Class B and the FCC Part 24 [Part 24.238]/RS133. It complies also with the FCC Part 15 [Part 15.109 and 15.209 in frequency range 30MHz to 18 GHz (subpart C)] class B.



6. ABBREVIATIONS AND DEFINITIONS

6.1. ABBREVIATIONS

AC	Alternative Current (Power source)
AC/DC	Alternative Current to Direct Current converter
AE	Auxiliary Equipment
AM	Amplitude Modulation
AV	Average
BER	Bit Error Rate
CW	Continuous Waves
dBm	Decibel milliwatt
DC	Direct Current
EFT/B	Electrical Fast Transient / Burst
EM	ElectroMagnetic
EMC	ElectroMagnetic Compatibility
EMI	Electro-Magnetic Interference
EN	European Norm
ERM	Electromagnetic compatibility and Radio spectrum Matters
ESD	ElectroStatic Discharge
ETS	ETSI Standard
EUT	Equipment Under Test
GRP	Ground Reference Plane
HCP	Horizontal Coupling Plane
IT	Information Technology
PE	Protective Earth
N/A	Not Applicable
NTP	Network Termination Point
RF	Radio Frequency
RFI	Radio Frequency Interference
TDMA	Time Division Multiple Access
VCP	Vertical Coupling Plane

6.2. DEFINITIONS

Air discharge method : a method of testing, in which the charged electrode of the test generator is brought close to the EUT, and the discharge actuated by a spark to the EUT.

Amplitude modulation : process by which the amplitude of a carrier wave is varied following a specified law.

Anechoic chamber : shielded enclosure which is lined with radio-frequency absorbers to reduce reflections from the internal surfaces.

Antenna : transducer which either emits radio-frequency power into space from a signal source or intercepts an arriving electromagnetic field, converting it into an electrical signal.

Antistatic material : material exhibiting properties which minimize charge generation when rubbed against or separated from the same or other similar materials.

Artificial hand : an electrical network simulating the impedance of the human body under average operational conditions between a hand-held electrical appliance and earth

Auxiliary equipment : equipment necessary to provide the EUT with the signals required for normal operation and equipment to verify the performance of the equipment under test.

Balanced lines : a pair of symmetrically driven conductors with a conversion loss from differential to common mode of less than 20 dB.

Balun : device for transforming an unbalanced voltage to a balanced voltage or vice versa.

Burst : a sequence of a limited number of distinct pulses or an oscillation of limited duration.

Contact discharge method : a method of testing, in which the electrode of the test generator is held in contact with the EUT, and the discharge actuated by the discharge switch within the generator.

Clamp injection : clamp injection is obtained by means of a clamp-on "current" injecting device on the cable.

Continuous waves : electromagnetic waves, the successive oscillations of which are identical under steady-state conditions, which can be interrupted or modulated to convey information.

Coupling clamp : device of defined dimensions and characteristics for common mode coupling of the disturbance signal to the circuit under test without any galvanic connection to it.

Coupling network : electrical circuit for the purpose of preventing EFT voltage applied to the EUT from affecting other devices, equipment or systems which are not under test.

Coupling plane : a metal sheet or plate, to which discharges are applied to simulate electrostatic discharge to objects adjacent to the EUT.

Current clamp : a transformer, the secondary winding of which consists of the cable into which the injection is made.

Current surge : the front time T_1 of a surge voltage is a virtual parameter defined as 1.25 times the interval T between the instants when the impulse is 10% and 90% of the peak value.

Decoupling network : electrical circuit for the purpose of preventing surges applied to the EUT from affecting other devices, equipment or systems which are not under test.



Degradation of performance : an undesired departure in the operational performance of any device, equipment or system from its intended performance.

Direct application : application of the discharge directly to the EUT.

Duration : the absolute value of the interval during which a specified waveform or feature exists or continues.

Electrical installation : an assembly of associated electrical equipment to fulfil a specific purpose or purposes and having coordinated characteristics.

Electromagnetic clamp : (EM-clamp) injection devices with combined capacitive and inductive coupling.

Electromagnetic compatibility : the ability of an equipment or system to function satisfactorily in its electromagnetic environment without introducing intolerable electromagnetic disturbances to anything in that environment.

Electromagnetic wave : radiant energy produced by the oscillation of an electric charge characterized by oscillation of the electric and magnetic field.

Electrostatic discharge : a transfer of electric charge between bodies of different electrostatic potential in proximity or through direct contact.

Energy storage capacitor : the capacitor of the ESD generator representing the capacity of a human body charged to the test voltage value. This may be provided as a discrete component, or a distributed capacitance.

Far field : region where the power flux density from an antenna approximately obeys an inverse square law of the distance.

Field strength : the term "field strength" is applied only to measurements made in the far field. The measurement may be of either the electric or the magnetic component of the field and may be expressed as V/m, A/m or W/m²; any one of these may be converted into the others.

Frequency band : continuous of frequencies extending between two limits.

Fully anechoic chamber : shielded enclosure whose internal surfaces are totally lined with anechoic material.

Ground reference plane : a flat conductive surface whose potential is used as a common reference

Holding time : interval of time within the decrease of the test voltage due to leakage, prior to the discharge, is not greater than 10%.

Human body-mounted equipment : equipment which is intended for use when attached to the human body. This definition included hand-held devices which are carried by people while in operation (e.g. pocket devices) as well as electronics aid devices and implants.

Immunity to a disturbance : the ability of a device, equipment or system to perform without degradation in the presence of an electromagnetic disturbance.

Indirect application : application of the discharge to a coupling plane in the vicinity of the EUT, and simulation of personnel discharge to objects which are adjacent to the EUT.

Induction field : predominant electric and/or magnetic field existing at a distance $d < \lambda/2\pi$, where λ is the wavelength and the physical dimensions of the source are much smaller than distance d .



Isotropic : having properties of equal values in all directions

Malfunction : the termination of the ability of an equipment to carry out intended functions or the execution of unintended functions by the equipment.

Maximum RMS value : the highest short-term RMS value of a modulated RF signal during an observation time of one modulation period. The short-term RMS is evaluated over a single carrier cycle.

Modified semi-anechoic chamber : semi-anechoic chamber which has additional absorbers installed on the ground plane.

Non-constant envelope modulation : RF modulation schemes where the amplitude of the carrier wave varies slowly in time compared with the period of the carrier itself. Examples include conventional modulation and TDMA.

Polarization : orientation of the electric field vector of a radiated field.

Port : particular interface of the EUT with the external electromagnetic environment

Primary protection : the means by which the majority of stressful energy is prevented from propagating beyond the designated interface.

Rise time : the interval of time between the instants at which the instantaneous value of a pulse first reaches 10% value and then the 90% values.

Secondary protection : the means by which the let-through energy from primary protection is suppressed. It may be a special device or an inherent characteristic of the EUT.

Semi-anechoic chamber : shielded enclosure where all internal surfaces are covered with anechoic material with the exception of the floor, which shall be reflective (ground plane).

Shielded enclosure : screened or solid metal housing designed expressly for the purpose of isolating the internal from the external electromagnetic environment. The purpose is to prevent outside ambient electromagnetic fields from causing performance degradation and to prevent emission from causing interference to outside activities.

Short interruption : the disappearance of the supply voltage for a period of time typically not exceeding 1 min. Short interruptions can be considered as voltage dips with 100% amplitude.

Spurious radiation : any undesired electromagnetic emission from an electrical device.

Stripline : terminated transmission line consisting of two parallel plates between which a wave is propagated in the transverse electromagnetic mode to produce a specified field for testing purposes.

Surge : a transient wave of electrical current, voltage, or power propagating along a line or a circuit and characterized by a rapid increase followed by a slower decrease.

Surge voltage : the front time T_1 of a surge voltage is a virtual parameter defined as 1.67 times the interval T between the instants when the impulse is 30% and 90% of the peak value.

Sweep : continuous or incremental traverse over a range of frequencies

System : set of interdependent elements constituted to achieve a given objective by performing a specified function.

TDMA : a time multiplexing modulation scheme which places several communication channels on the same carrier wave at an allocated frequency. Each channel is assigned a time slot during which, if the channel is active, the information is transmitted as a pulse of RF power. If the



channel is not active no pulse is transmitted, thus the carrier envelope is not constant. During the pulse, the amplitude is constant and the RF carrier is frequency or phase modulated.

Time to half-value T_2 : the time to half value T_2 of a surge is a virtual parameter defined as the time interval between the virtual origin O_1 and the instant when the voltage current has decreased to half the peak value.

Transceiver : Combination of radio transmitting and receiving equipment in a common housing.

Transient : pertaining to or designating a phenomenon or a quantity which varies between two consecutive steady states during a time interval which is short compared with the time-scale of interest.

Voltage dips : a sudden reduction of the voltage at a point in the electrical system, followed recovery after a short period of time, from half a cycle to a few second.

Voltage variation : a gradual change of the supply voltage to a higher or lower value than the rated voltage. The duration of the change can be short or long with regard to the period.

❧END OF DOCUMENT❧



Accreditation
N° 1-0312



TEST REPORT

N° 60056545-557308C

FCC REGISTRASTION NUMBER 93402
INDUSTRY CANADA NUMBER 6231

ISSUED TO : NORTEL
Parc d'activités de Magny-Châteaufort
78928 YVELINES Cedex 09

SUBJECT : **ELECTROMAGNETIC COMPATIBILITY TESTS ACCORDING TO THE PUBLICATIONS 47 CFR PART 15 CLASS B of 2006 , ICES003 CLASS B of 2004, 47 CFR PART 22 of 2004 and RSS132 of 2005**

Apparatus under test :

- Product : BASE STATION
- Trade mark : NORTEL
- manufacturer : NORTEL NETWORKS
- type : GSM 850 BTS 6000 OUTDOOR (D.C.)
- Serial number : -

Test date : May 2007

Composition of document : 15 pages + 2 related documents

Fontenay-aux-Roses, May 23th, 2007

The technical manager,

Eric ROUSSEL



This document shall not be reproduced, except in full, without the written approval of the LCIE. This document contains results related only to the items tested. It does not imply the conformity of the whole production to the items tested. The COFRAC accreditation attests the technical capability of the testing laboratory for the only tests covered by the accreditation.



1 - GENERAL

1.1 - Manufacturer identification

Manufacturer : NORTEL
Address : Parc d'activités de Magny-Châteaufort
78928 YVELINES Cedex 09

2 - TESTING PROGRAM

Test have been carried out according to the following specifications :

- Measurement of continuous conducted disturbances in the frequency range 0.15 MHz to 30 MHz - publication 47CFR Part. 15 subpart B (§ 107) class B of 2000 and standard CISPR 22 (§9) class B of 2003
- Measurement of radiated disturbances in the frequency range 30 MHz to 18 GHz - publication 47CFR Part. 15 subpart B (§ 109) ,class B of 2006
- Measurement of radiated disturbances in the frequency range 30 MHz to 6 GHz - standard CISPR 22 (§10) class B of 2005 and amendment 1 of 2005
- Measurement of radiated disturbances in the frequency range 30 MHz to 20 GHz – Publication 47CFR Part. 22 subpart H (§ 22.917) and RSS132 (§ 4.5)

The ICES003 standard use CISPR 22 standard method and limit.

3 - EQUIPMENT CHARACTERISTICS

3.1 - Label identification

No number plate statement.
(see hardware and software descriptions of the related document provided by NORTEL , reference : PE/BTS/DJD/022074 issue 02.01/EN).

3.2 - Equipment configuration

The configuration of the equipment under test is described on the related documents reference LCIE 60056545-557308-C-TP-FCC and NORTEL - PE/BTS/DJD/022074 issue 02.01/EN.

The position of apparatus under test is given in the photograph in annex.

During the measurements, the apparatus was operating in transmitter mode and the output transmitters were connected to 50 Ohms loads.

All transmitters were at maximum power 60W

The frame of the BTS was grounded.

4 - OPERATING CONDITIONS

The apparatus was placed in an open field site located rue Théo Bonhomme at ECUELLES (Seine-et-Marne) was powered with a DC source delivering -48V

. Climatic conditions: ambient temperature : 20 to 23°C
relative humidity : 38 to 51%
atmospheric pressure : - hPa



5 - TESTING RESULTS

5.1 DISTURBANCES MEASUREMENT- CISPR22 , 47CFR Part. 15

Apparatus class : B

TEST	TEST SPECIFICATION	RESULTS			
		P	F	NA	Rem
<u>Limits for conducted disturbances at mains ports</u>	Frequency range : 0.15MHz to 30 MHz Diagrams No 1 and 2	[X]	[]	[]	[1]
<u>Limits for radiated disturbances</u>	Frequency range : 30 MHz to 18000 MHz Antennas : - bilog (30 MHz to 1000 MHz) - Horn (1 GHz to 18 GHz) Diagrams No 3 and 4 and table n° 1	[X] [X]	[] []	[] []	[] [2]

P : pass - F : fail - NA : not applicable - Rem : remark

Remark

N° 1 : tested for information only

N° 2 : no frequency between 1 GHz to 18 GHz



5.2 DISTURBANCES MEASUREMENT -47CFR Part. 22 subpart H (§ 22.917) and RSS132 (§ 4.5)

5.2.1-Test procedure

Radiated emission measurement procedures shall be performed as outlined in Section 8 of the ANSI C63.4 measurement standard.

The measurements have been carried out in two steps : the identification of the frequencies and the measurement of the radiated field.

5.2.2- The identification of the frequencies (pre scan)

The apparatus was placed inside a shielded room.

The measurement antenna is placed near the apparatus and connected to a spectrum analyzer.

The observation of the radioelectric spectrum is allowed to identify the spurious frequencies to the equipment under test.

5.2.3 -Measurement of the radiated field.

Measurements have been carried out in an open field site with the following antennas :

- Bilog antenna : 30MHz to 1000MHz
- Horn type : EMCO 3115 : 1GHz to 18GHz
- Horn type : AH SYSTEMS SAS-572 : 18GHz to 20GHz

Antennas were placed at 10 m from the equipment under test and connected successively to a spectrum analyzer equipped with a radiofrequency preselector, a preamplifier and a quasi peak-adaptor.

Antennas height was adjusted between 1m and 4 m in order to obtain the maximal electric field value

The equipment under test was placed on a turntable in order to present the side giving the highest level disturbance.

5.2.4 Limits for radiated emissions from FCC Part 22, and RSS132.

Frequency range	Minimum requirement (e.r.p.)/Reference Bandwidth
30 MHz ≤ f < 20 GHz	The spurious emissions must be attenuated by at least $43 + 10 \text{ Log}(P)$ P = Transmitter rated Power in Watts

Measurements were made according to the procedures outline in ANSI C63.4
 The emissions were investigated up to the tenth harmonic of the fundamental emission (20 GHz).
 The measured level of the emissions was recorded and compared to the limit.
 The reference level for spurious radiation was taken with reference to an ideal dipole antenna excited by the rated output power according to the following relationship :

$$E(V / m) = \frac{1}{R(m)} * \sqrt{30 * P_t * G}$$

Where,

- E = Field Strength in Volts/meter,
- R = Measurement distance in meters,
- P_t = Transmitter Rated Power in Watts (60 Watts),
- G = Gain of ideal Dipole (linear)

Therefore :

$$E(V / m) = \frac{1}{10} * \sqrt{30 * 60 * 1.64}$$

E = 5.43 V/m = 134.7 dBμV/m
 The spurious emissions must be attenuated by at least 43 + 10*Log(60) = 60.7 dB.
 Therefore the field strength limit at 10 meters is :
 E = 134.7 dBμV/m – 60.7 dB = 74 dBμV/m

Limit Level = 74 dBμV/m

5.2.5 Spectrum Analyzer setting:

Receiver Setting	Pre-Scan (to identify spurious emissions from EUT)	Final Measurements
Detector Type	Peak	Quasi-Peak (CISPR) for 30 MHz - 1GHz Peak for 1GHz - 20GHz
Mode	Max Hold	Not Applicable
Bandwidth	100 kHz or 1 MHz (for > 1GHz)	120 kHz Quasi-Peak 100 kHz or 1 MHz (for > 1GHz)
Amplitude Range	60 dB	20 dB
Measurement Time	Not Applicable	> 1s
Observation Time	Not Applicable	> 15s
Step size	Continuous sweep	Not Applicable
Sweep Time	Coupled	Not Applicable
Measuring Distance	3m for 30 MHz - 1GHz 1m for 1GHz - 20GHz	10m for 30 MHz - 1GHz 10m for 1GHz - 20GHz



L C I E

5.2.6- Testing results

TEST	TEST SPECIFICATION	RESULTS			
		P	F	NA	Rem
<u>Limits for radiated disturbances</u>	Frequency range : 30 MHz to 20000 MHz				
	Antenna :				
	- bilog (30 MHz to 1000 MHz)	<input checked="" type="checkbox"/>	<input type="checkbox"/>	<input type="checkbox"/>	[1]
	- Horn (1 GHz to 18 GHz)	<input checked="" type="checkbox"/>	<input type="checkbox"/>	<input type="checkbox"/>	[1]
	- Horn (18 GHz to 20 GHz)	<input checked="" type="checkbox"/>	<input type="checkbox"/>	<input type="checkbox"/>	[1]
	Diagram No 5 + table n° 1				

P : pass - F : Fail - NA : not applicable - Rem : remark

Remark N° 1 : During the Pre-Scan at 1 meter, no spurious frequencies has been detected in the frequency range 1GHz to 20 GHz.
Same result for 47CFR Part. 22 subpart H (§ 22.917) of 2004 and RSS132 (§ 4.5) of 2005.

6 - CONCLUSION

The apparatus of manufacturer NORTEL and model GSM 850 BTS 6000 OUTDOOR (D.C.) is in compliance with the requirements of the publications 47 CFR PART 15 Subpart B (§107 and § 109 in the frequency range 30 MHz to 18 GHz) class B of 2006, ICES003 class B , 47CFR Part. 22 subpart H § 22.917(in the frequency range 30 MHz to 20 GHz) of 2004 and RSS132 (§ 4.5) of 2005.

**Table n° 1**

Measurement at transmitters frequencies for indicative level

Frequency (MHz)	Channel	Level (dB μ V/m)
869.2	Bottom	62
881.6	Middle	66
893.8	Top	65



L C I E

Diagram n°1

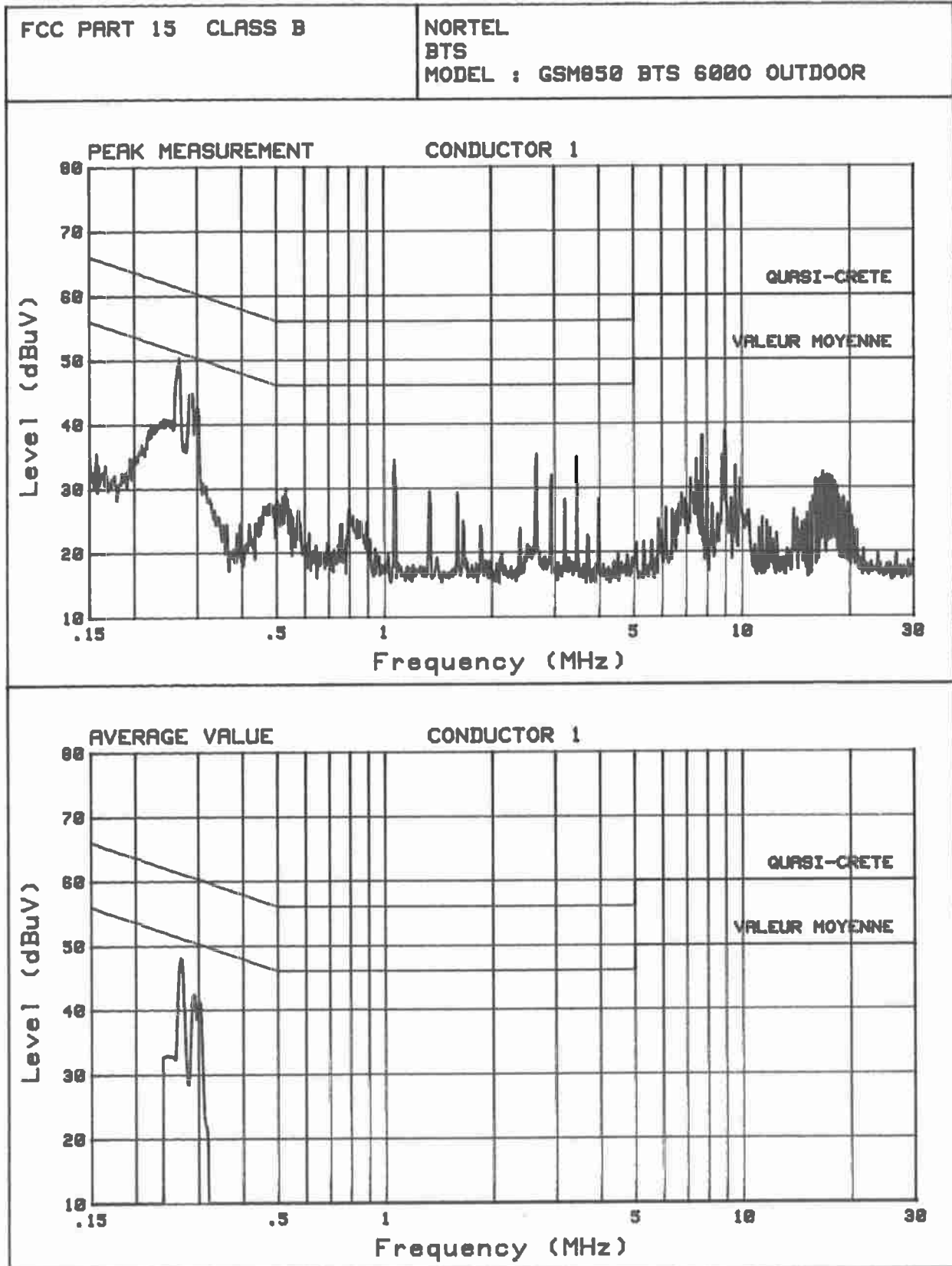



L C I E

TEST REPORT N° 60056545-557308C

Page 9

Diagram n° 2

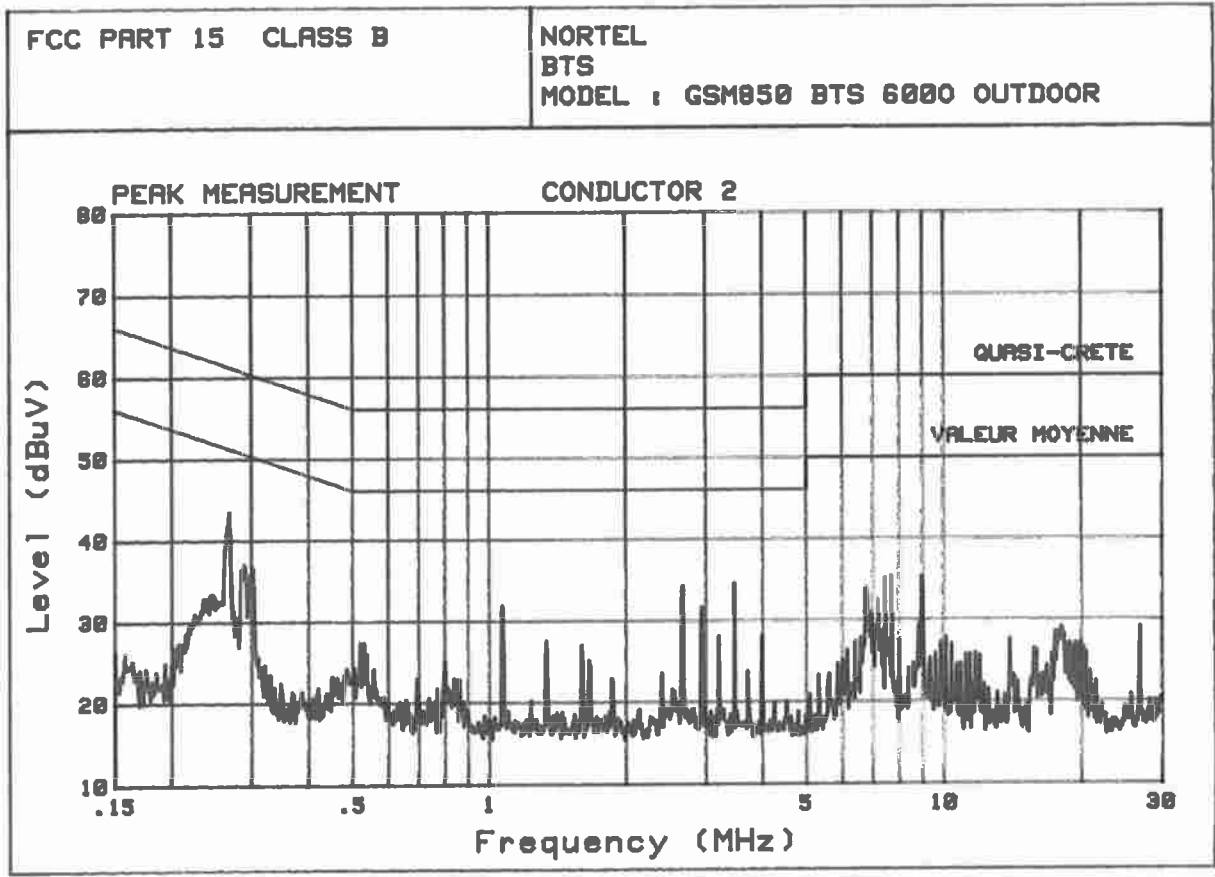



L C I E

TEST REPORT N° 60056545-557308C

Page 10

Diagram n°3

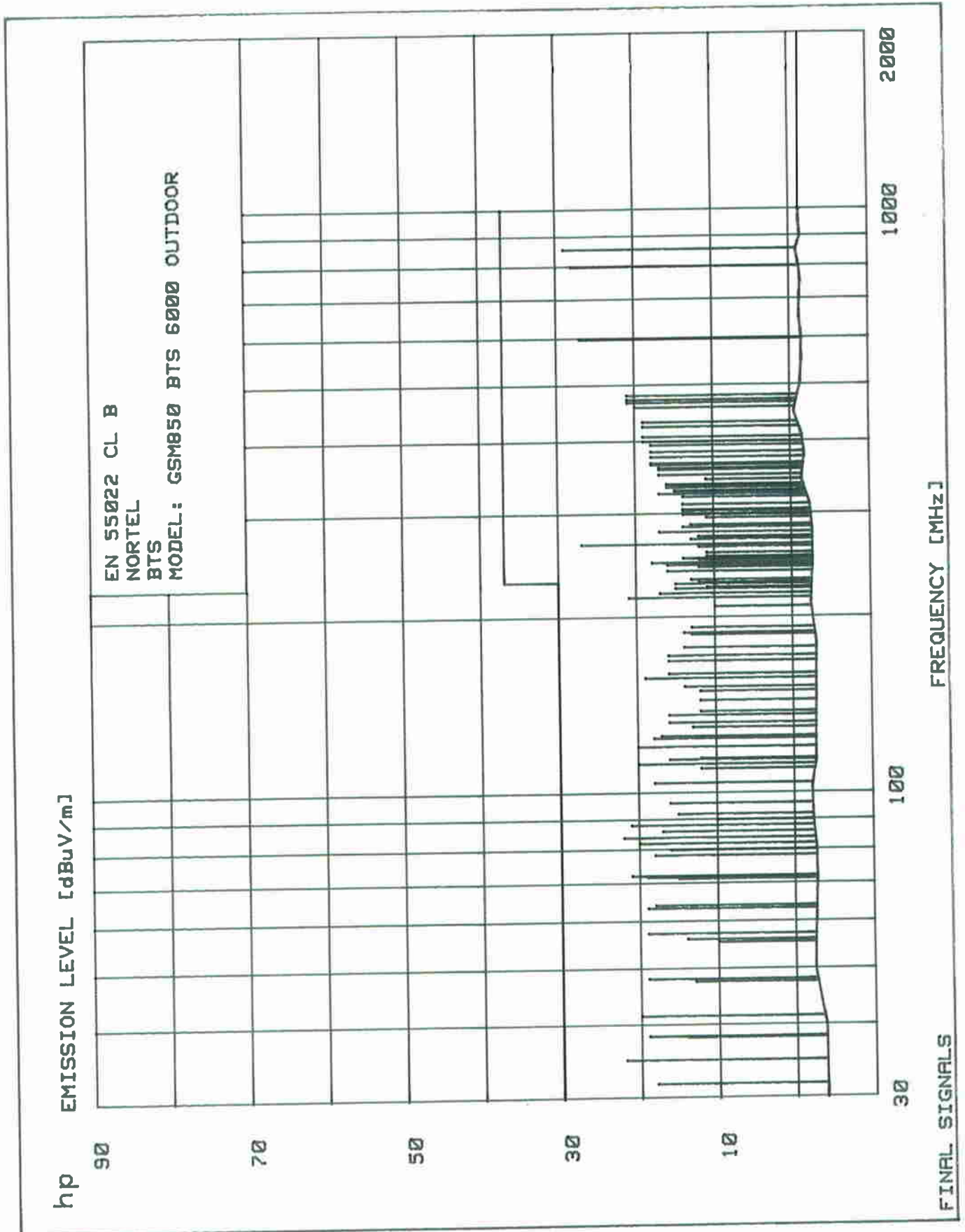



L C I E

Diagram n°4

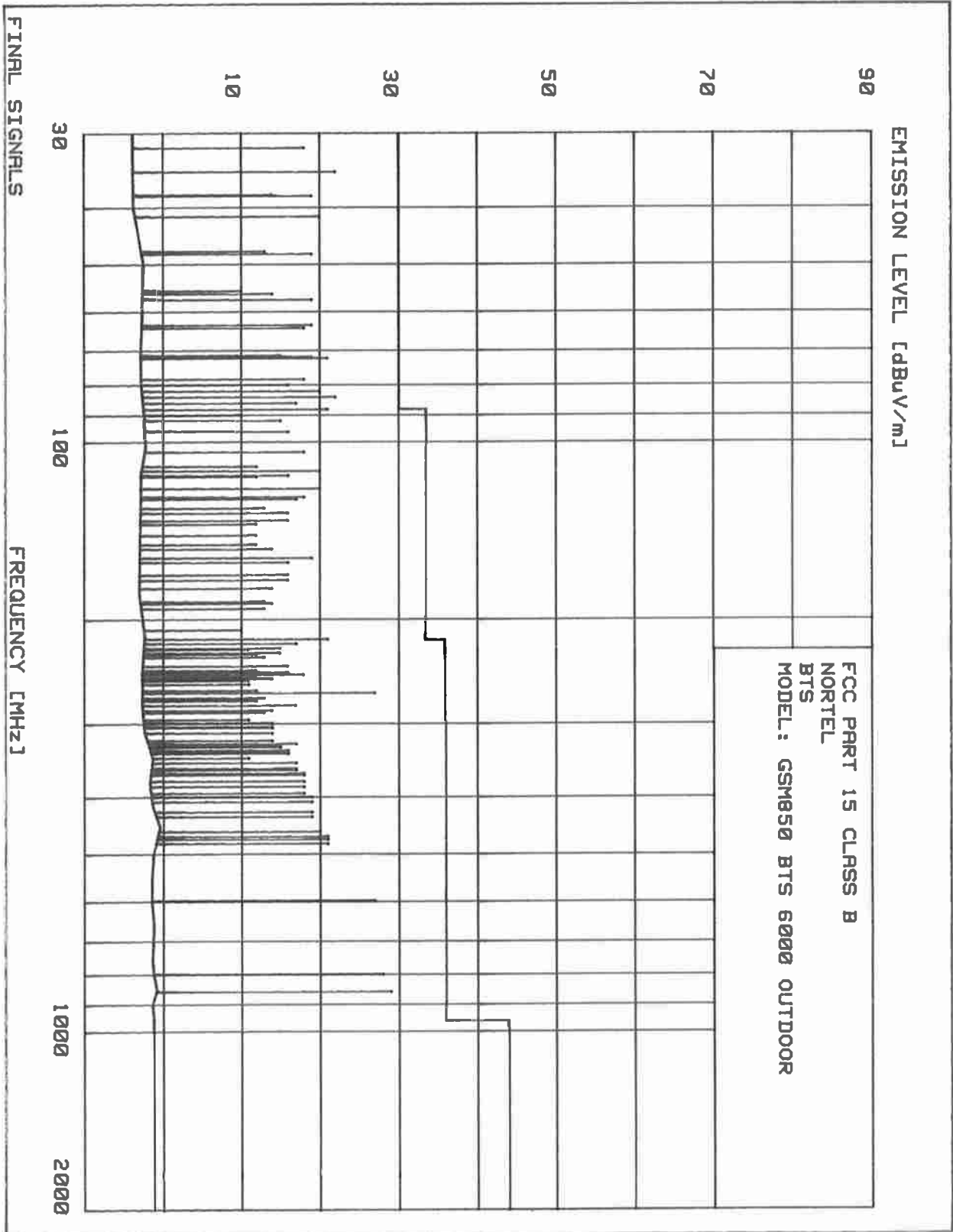



L C I E

Diagram n° 5

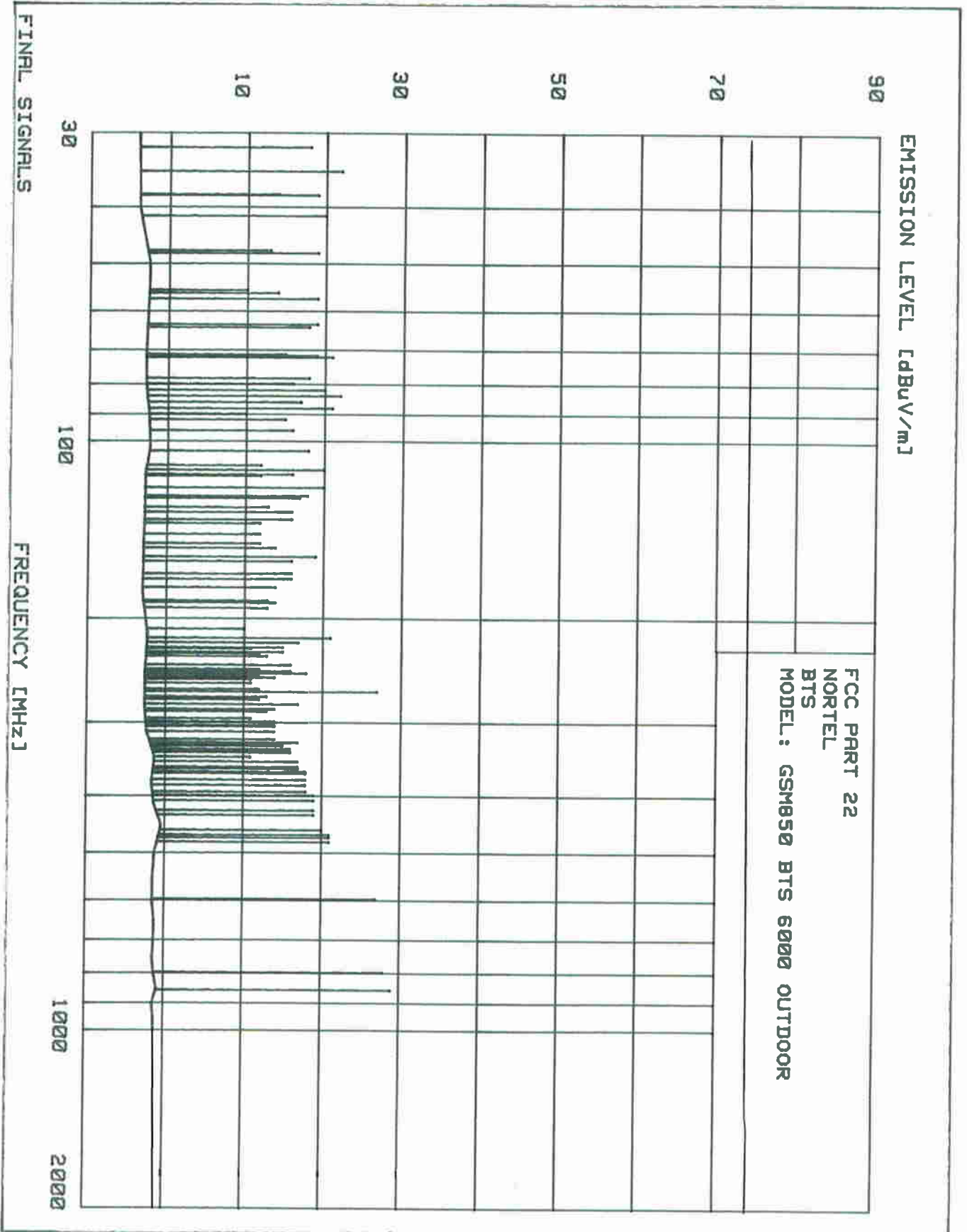
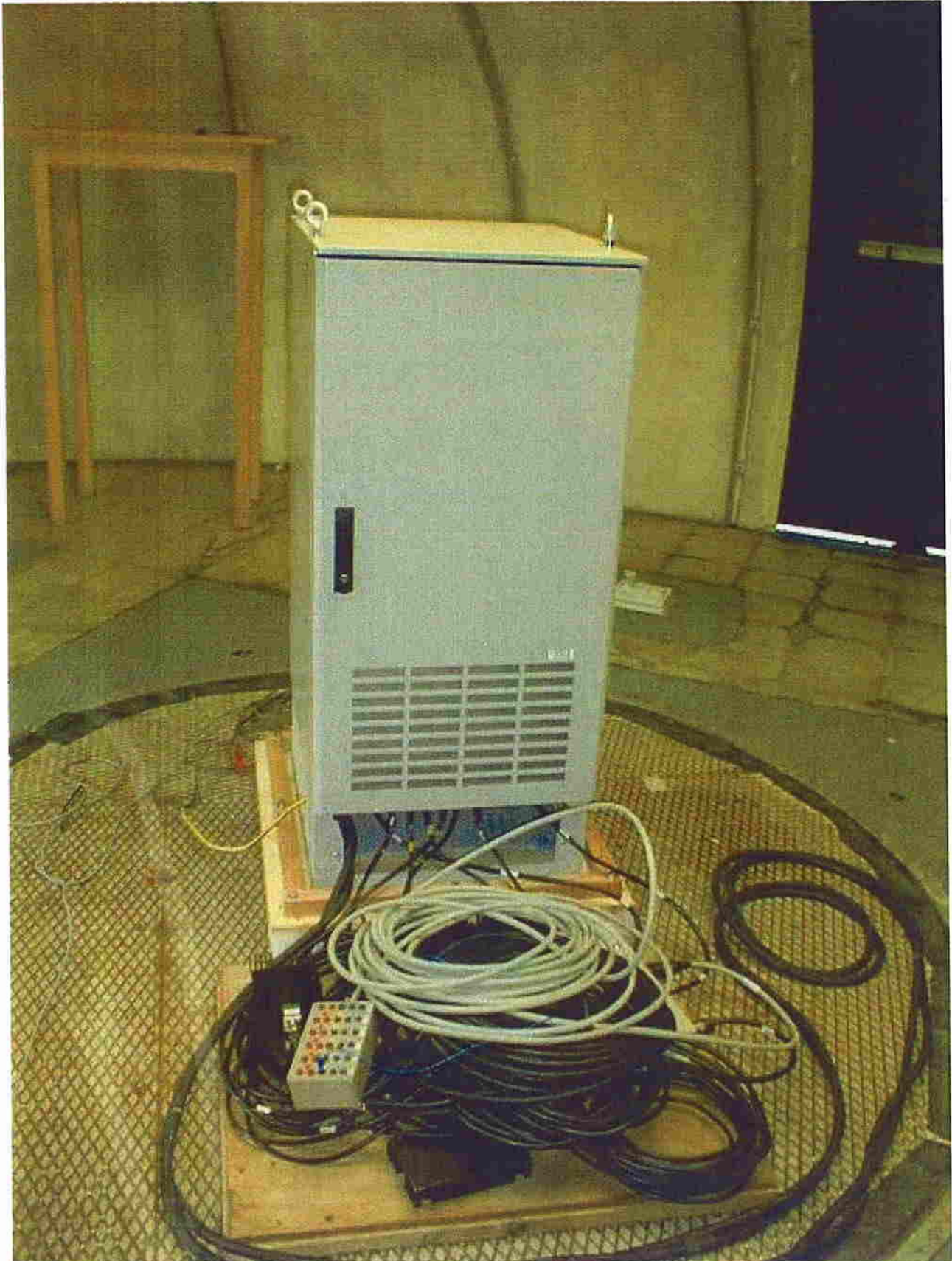

Photo N° 1





LISTE DU MATERIEL / EQUIPMENT LIST

Test	Appareil / Apparatus	Marque / Trade Mark	Type / Type	Immatriculation / Registration number
<i>Essais en espace libre / Open area test site</i>				
X	Analyseur de spectre/ Spectrum analyseur	HEWLETT PACKARD	8566B	A4060004
X	Présélecteur / Preselector	HEWLETT PACKARD	85685A	A4069001
X	Adaptateur quasi-crête / Quas-Peak adaptor	HEWLETT PACKARD	85650A	B2163019
X	Préamplificateur / Preamplifier	HEWLETT PACKARD	8449B	A4069002
	Générateur / Signal Generator	HEWLETT PACKARD	8657A	A5442003
	Générateur / Signal Generator	HEWLETT PACKARD	E4433B	A5488014
	Générateur / Signal Generator	ROHDE & SCHWARZ	SMP02	B2163019
	Mire	PHILIPS	PM 5518-TX	A5240009
	RLTE	SECRET	ENS 1039	C2324001
	Coupleur / Coupler	NARDA	3020A	C5364002
	Coupleur / Coupler	SALIES	3060-20	C5364001
X	Réseau V / V ISLN	ROHDE & SCHWARZ	ESH2-Z5	C2322001
	Réseau V / V ISLN	ROHDE & SCHWARZ	ESH3-Z6	C2322020
X	Antenne bilog / Bilog antenna	CHASE	CBL 6112A	C2040040
	Antenne bilog / Bilog antenna	AH SYSTEM	SAS-2001251	C2040025
	Dipole large bande /	ROHDE & SCHWARZ	HUF-Z1	C2040011
	Antenne logpériodique / Logperiodic antenna	ROHDE & SCHWARZ	HL 023 A2	C2040001
	Antenne logpériodique / Logperiodic antenna	E/D	AN112	C2040029
x	Antenne cornet / Horn antenna	AH SYSTEMS	SAS-572	
X	Antenne cornet / Horn antenna	EMCO	.3115	C2042016



TABLE DES INCERTITUDES / UNCERTAINTIES CHART

Type de mesure / Kind of measurement	Incertitude élargie laboratoire / Wide uncertainty laboratory (k=2) ±x(dB)	Incertitude limite du CISPR / CISPR uncertainty limit ±y(dB)
Mesure des perturbations conduites en tension sur le réseau d'énergie « alternatif » sur le site de Fontenay-aux-Roses / <i>Measurement of conducted disturbances in voltage on the AC power port on the Fontenay-aux-Roses site.</i>	3.56	3.6
Mesure des perturbations conduites en tension sur le réseau d'énergie « alternatif » sur le site en espace libre d'Ecuelles / <i>Measurement of conducted disturbances in voltage on the AC power port on the Ecuelles site.</i>	3.50	3.6
Mesure des perturbations conduites en tension sur le réseau d'énergie « continu » sur le site de Fontenay-aux-Roses / <i>Measurement of conducted disturbances in voltage on the DC power port on the Fontenay-aux-Roses site.</i>	3.56	3.6
Mesure des perturbations conduites en tension sur le réseau d'énergie « continu » sur le site en espace libre d'Ecuelles. / <i>Measurement of conducted disturbances in voltage on the DC power port on the Ecuelles site.</i>	3.56	3.6
Mesure des perturbations conduites en tension sur le réseau de télécommunication / <i>Measurement of conducted disturbances in voltage on the telecommunication port.</i>	3.28	A l'étude / Under consideration
Mesure des perturbations conduites en courant / <i>Measurement of conducted disturbances in current</i>	2.90	A l'étude / Under consideration
Mesure du champ électrique rayonné de 30 à 200MHz en polarisation horizontale sur le site de Fontenay-Aux-Roses / <i>Measurement of radiated electric field from 30 to 200MHz in horizontal position on the Fontenay-aux-Roses site</i>	4.58	5.2
Mesure du champ électrique rayonné de 30 à 200MHz en polarisation verticale sur le site de Fontenay-Aux-Roses / <i>Measurement of radiated electric field from 30 to 200MHz in vertical position on the Fontenay-aux-Roses site</i>	4.82	5.2
Mesure du champ électrique rayonné de 200 à 1000MHz sur le site de Fontenay-Aux-Roses / <i>Measurement of radiated electric field from 200 to 1000MHz on the Fontenay-aux-Roses site</i>	4.92	5.2
Mesure du champ électrique rayonné de 1 à 18GHz sur le site de Fontenay-Aux-Roses / <i>Measurement of radiated electric field from 1 to 18GHz on the Fontenay-aux-Roses site</i>	6.54	A l'étude / Under consideration
Mesure du champ électrique rayonné de 30 à 1000MHz sur le site en espace libre d'Ecuelles / <i>Measurement of radiated electric field from 30 to 1000MHz on the Ecuelles site</i>	4.72	5.2
Mesure du champ électrique rayonné de 1 à 6GHz sur le site en espace libre d'Ecuelles / <i>Measurement of radiated electric field from 1 to 6GHz on the Ecuelles site</i>	5.60	A l'étude / Under consideration
Mesure du champ électrique rayonné de 6 à 18GHz sur le site en espace libre d'Ecuelles / <i>Measurement of radiated electric field from 6 to 18GHz on the Ecuelles site</i>	5.83	A l'étude / Under consideration
Mesure de la puissance perturbatrice / <i>Measurement of disturbance power</i>	3.37	4.5
Immunité aux perturbations conduites, induites par les champs radioélectriques / <i>Immunity to conducted disturbances, induced by radio electric field</i>	2.36	/
Immunité aux perturbations conduites, induites par les champs radioélectriques, méthode de la pince d'injection / <i>Immunity to conducted disturbances, induced by radio electric field, method oh the injection clamp</i>	2.76	/
Immunité aux champs radioélectriques rayonnés de 80MHz à 2.6GHz / <i>Immunity to radiated radio electric field from 80MHz to 2.6GHz</i>	2.64	/

Les valeurs d'incertitudes calculées du laboratoire étant inférieures aux valeurs d'incertitudes limites établies par le CISPR, la conformité de l'échantillon est établie directement par les niveaux limites applicables. / *The uncertainty values calculated by the laboratory are lower than limit uncertainty values defined by the CISPR. The conformity of the sample is directly established by the applicable limits values.*



LABORATOIRE CENTRAL
DES INDUSTRIES ELECTRIQUES
RELATED DOCUMENT N° 1
to test report N° 60056545-557308-C
20 pages

EMC Test plan for the introduction of RICAM and GSM 850MHz band in GSM 6000 BTS (FCC)

Reference: 60056545-557308-C-TP-FCC

Version: A

Status: Approved

Date: 19/Apr/2007

Customer: NORTEL NETWORKS
Parc d'Activités de Magny-Châteaufort
78928 Yvelines Cedex 09

Product: GSM 6000 BTS

Author: Marc CANCOUËT

Technical Manager: Didier PRADON

27/04/2007

This document shall not be reproduced, except in full, without the written approval of the LCIE.



PUBLICATION HISTORY

VERSION	DATE	AUTHOR	MODIFICATION
A	19-Apr-07	M. CANCOUET	Creation of document



CONTENTS

1.	INTRODUCTION	4
2.	RELATED DOCUMENTS	7
2.1.	APPLICABLE STANDARDS	7
2.2.	REFERENCE DOCUMENTS	7
3.	STRATEGY FOR THE EMC QUALIFICATION.....	8
4.	REQUIREMENTS BEFORE EMC ASSESSMENT	9
4.1.	HARDWARE TECHNICAL STATUS	9
4.2.	LIST OF KITS AND CABLES	11
4.2.1	LIST OF KITS.....	11
4.2.2	LIST OF CABLES	11
4.3.	SOFTWARE NEEDS FOR GSM 6000 BTS	11
5.	TEST PLAN SUMMARY	12
5.1.	TEST PLAN SUMMARY FOR EMISSIONS TESTING	12
6.	TEST CONFIGURATION	13
6.1.	TEST CONFIGURATION FOR EMISSIONS TESTING	13
7.	ABBREVIATIONS AND DEFINITIONS.....	14
7.1.	ABBREVIATIONS	14
7.1.1	General Abbreviations	14
7.1.2	GSM Abbreviations	15
7.2.	DEFINITIONS	17



1. INTRODUCTION

This document presents the EMC tests plan for the FCC EMC qualification of GSM 6000 BTS in the 850 MHz frequency band and the introduction of RICAM digital board.

For North America, applicable standard for EMC Base stations are the FCC part 15/ICES 003 Class B and the FCC Part 22/RS132.

During this campaign, we also realized the introduction of RICAM GSM850 RICAM BTS 6000 for CE Marking.

We plan to use harmonized EMC standards (EN 301 489-1 v1.4.1 & EN 301 489-8 v1.2.1) in order to self declare the compliance of the BTS regarding the R&TTE directive.

We used also the standard CISPR 22 for some other customer requirements.

This document presents the tests that will be performed in order to have the CE mark.

The following table gives some information of the EUT :

Product Name	GSM 6000 BTS
Manufacturer	NORTEL
Serial Number	-
Alimentation of the EUT	AC or DC



The following configurations will be covered:

- Standard single band RF configurations:
 - Up to S33 configuration with a single cabinet configuration
 - Support of extension cabinets (up to 3 cabinets with 3 S666)

- Modules covered:
 - 900 Mhz MPRM 40w GMSK / 40w EGPRS Powerwave and Andrew
 - 900 Mhz HPRM 60w GMSK / 45w EGPRS PowerWave
 - 1800 MHz RM 30w GMSK/ 30w EGPRS Powerwave
 - 1800 MHz MPRM 40w GMSK/ 40w EGPRS Andrew
 - 1900 MHz RM 30w GMSK/ 30w EGPRS
 - 850MHz HPRM (3T - 60W GMSK/ 45W 8PSK)
 - All Coupling devices configurations including:
 - DDM_H2, DDM_D and mixed configuration with and without VSWR Filtronic and Mitec
 - TX filter_H2, TX filter and mixed configuration with and without VSWR Filtronic
 - Simplex ICM and duplex ICM configurations
 - IFM1
 - RICAM & ICAM
 - Both E1 (75/120 Ohm modes) and T1 (100 Ohm) PCM interfaces
 - RMPSU 48V Artesyn
 - RMPSU ASTEC and ARTESYN
 - Rectifiers: 1.0 kW Artesyn and 1.4 kW Astec and Artesyn, including mixed configurations between all rectifiers.
 - UCPS UMTS/GSM CCU

- Energy:
 - AC power; 2 configurations available for outdoor and Indoor cabinet:
 - 230VAC, single phase, Two wires plus protective earth, 200-240V -10%/+10%
 - 120/240VAC, Split phase Europe, Three wires plus protective earth, 200-240V -10%/+10%
 - DC power; 1 configuration available for Indoor cabinet only:
 - - 48 V

- Options for Outdoor and Indoor cabinet:
 - Alarm protection module (CALPRO2)
 - Primary protection module (CPRIPRO2)
 - CUserICO



- Options for Outdoor AC cabinet only:
 - Internal battery (SAFT)
 - AC Heater
 - Outdoor enclosure (door and second skin)
 - CUCPS for power supply management

- Options for Indoor AC cabinet only:
 - CUCPS for power supply management
 - Indoor enclosure (door and no second skin)
 - Internal battery

- Options for Indoor DC cabinet only:
 - DC Breaker pannel (DC Box)
 - Indoor enclosure (door and no second skin)

- Stand alone module:
 - CECU

The following modules or options are not covered:

- SPM
- Modules to be included in "user rack"

This document is addressed to Nortel and LCIE people in charge with GSM products qualification.



2. RELATED DOCUMENTS

2.1. APPLICABLE STANDARDS

[A1]	CFR 47 Part 2	Code of Federal Regulations - Part 2 - Frequency Allocations and Radio Treaty Matters. General Rules and Regulations. Date : June 1996.
[A2]	47 CFR Part 15 08/20/02	FCC Rules for Radio Frequency Devices, Title 47 of the Code of Federal Regulations – Radio frequency devices – dated 08/20/02
[A3]	CFR 47 Part 22	Code of Federal Regulations - Part 22 - Public Mobiles Services.
[A4]	IC ES 003 (NMB 003)	Industry Canada - Digital apparatus
[A5]	RSS 132	Industry Canada - 800 MHz Cellular Telephones Employing New Technologies.
[A6]	EN 55022	Information technology equipment – Radio disturbance characteristics – Limits and methods of measurement (1998).
[A7]	CISPR 22	Limits and methods of measurement of radio disturbance characteristics of information technology equipment (2006)
[A8]	EN 301 489-1	Electromagnetic compatibility and Radio spectrum Matters (ERM); ElectroMagnetic Compatibility (EMC) standard for radio equipment and services; Part 1 : Common technical requirements.
[A9]	EN 301 489-8	ElectroMagnetic compatibility and Radio spectrum Matters (ERM); ElectroMagnetic Compatibility (EMC) standard for radio equipment and services; Part 8 : Specific conditions for GSM base stations.

2.2. REFERENCE DOCUMENTS

[R1]	PE/BTS/DPL/021882	GSM 6000 BTS Project Qualification Plan For GSM850&PCS1900 Cabinet and RICAM Introduction for CE & FCC Marking
------	-------------------	--



3. STRATEGY FOR THE EMC QUALIFICATION

The aim of this paragraph is to present the strategy of EMC tests for the FCC qualification of GSM 6000 BTS in the 850 MHz frequency band and the introduction of RICAM digital board as described in the document referenced [R1].

For the FCC qualification of GSM 6000 BTS in the 850 MHz frequency band and the introduction of RICAM digital board, we plan to realize a full EMC qualification on GSM 6000 BTS Outdoor cabinet in AC and DC versions, and on GSM 6000 BTS Indoor cabinet in DC version only.

The GSM 6000 BTS Indoor cabinet in AC version will be introduced by similarity with GSM 6000 BTS Outdoor cabinet in AC version.

Those both versions are identical except door, enclosure and gaskets. Gaskets of Outdoor version are less efficient than Indoor version gaskets concerning EMC aspect, so we'll be able to deduce EMC conformity of GSM 6000 BTS Indoor cabinet in AC version from results of GSM 6000 BTS Outdoor cabinet in AC version.

For the introduction of RICAM digital board on GSM 6000 BTS cabinet for CE marking, we plan to realize only complementary emissions tests on GSM 6000 BTS Outdoor cabinet in AC and DC versions, and on GSM 6000 BTS Indoor cabinet in DC version only.

The GSM 6000 BTS Indoor cabinet in AC version will be introduced by similarity with GSM 6000 BTS Outdoor cabinet in AC version.

For CE marking, the introduction of RICAM digital board on GSM 6000 BTS cabinet will be realized on paper works by analysis of this complementary emissions tests and the previous EMC campaign realized on the GSM DCR 18000 Indoor BTS.



4. REQUIREMENTS BEFORE EMC ASSESSMENT

4.1. HARDWARE TECHNICAL STATUS

Details on the technical status of the system will be available in the document, supplied by Nortel during the commissioning & acceptance phase form for GSM 6000 BTS.

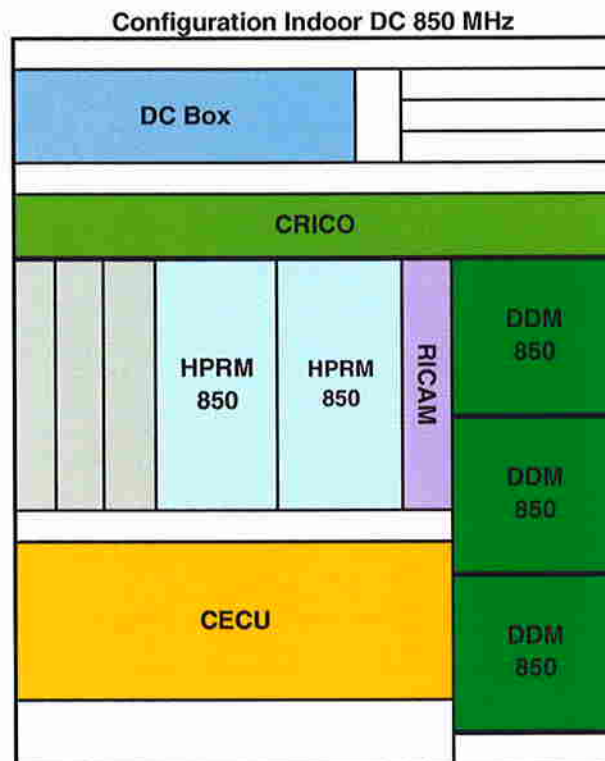



Configuration Outdoor DC 850 MHz

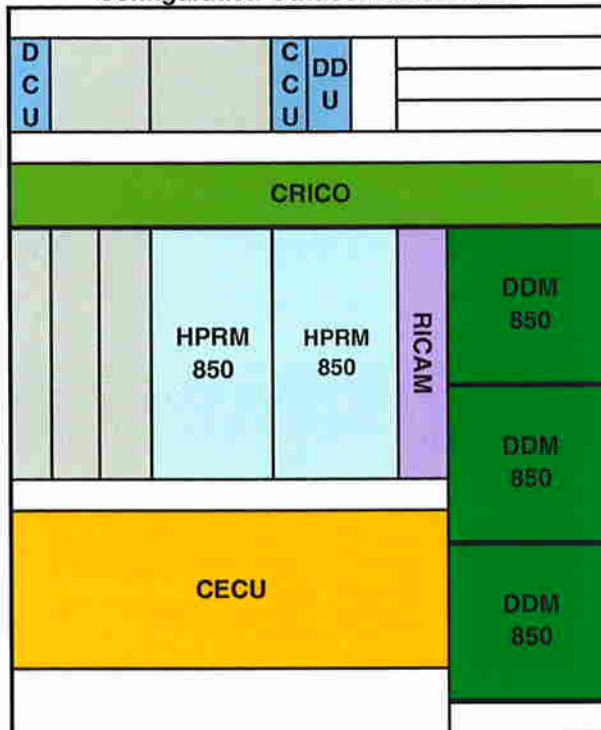

Configuration Outdoor AC 850 MHz

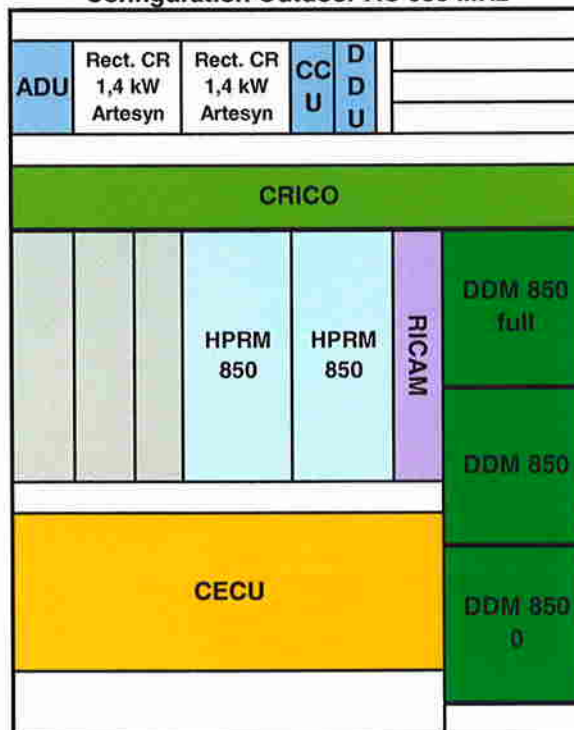



4.2. LIST OF KITS AND CABLES

4.2.1 LIST OF KITS

In fact, protections modules are optional but can be used to protect the PCM links & the Alarms links. These modules are made only with passive components and then are not critical modules for the system.

Kits are the following :

- Kits: PCM lightning protection (CPRIPRO 2)
- EAM lightning protection (CALPRO2)

4.2.2 LIST OF CABLES

The following ports of the GSM 6000 BTS are available and will be connected :

- Abis port (telecom port) : cable 120 Ω . This cable will be looped in order to transmit TX signals on RX ones.
- GSM external Alarms ports: 1 cable will be looped and the other cable will be in open circuit.
- Radio port (signal port) : 6 RF cables RADIALL SHF9TD – DC-2GHz – Insertion loss < 5.5 dB at 2 GHz (15 meters). Attenuators and loads will also be used on RF links.
- AC ports : Lab cables (about 10 meters).
- DC ports : Lab cables (about 10 meters).

4.3. SOFTWARE NEEDS FOR GSM 6000 BTS

For emissions, we have to configure the equipment with the power amplifiers set at their maximum rated level, and looped back the Abis link in order to generate activity inside this cable.

If one of the above functionality is not available for the testing phase, we will not be able to perform the FCC marking based on the tests realized.



5. TEST PLAN SUMMARY

5.1. TEST PLAN SUMMARY FOR EMISSIONS TESTING

The following table presents the test plan summary for the FCC & IC qualification of GSM 850MHz 6000 BTS :

Test case	Application	Test requirement	Performance criteria	Comment	
Emission tests					
1	Conducted Emissions FCC Part 15 § 15.107 & ICES 003	AC port DC port	150 kHz to 30 MHz	Class B	DC port realized for information only
2	Radiated emissions FCC part 15 § 15.109 & ICES 003	E- field enclosure	30 MHz to 18 GHz	Class B	
3	Radiated emissions spurious FCC part 22 § 22.917 & RS132	E- field enclosure	30 MHz to 20 GHz	The spurious emissions must be attenuated by at least $43 + 10 \text{ Log}(P)$ P = Transmitter rated Power in Watts	

The following table presents the test plan summary for the complementary emissions tests for the introduction of RICAM digital board on GSM 6000 BTS cabinet.

EMC standards covered: (EN 301 489-1 v1.4.1, EN 301 489-8 v1.2.1).

Test case	Application	Test requirement	Performance criteria	Comment	
Emission tests					
4	EN 55022 & CISPR 22 Conducted Emissions	AC Port DC Port	150 kHz to 30 MHz	Class A	Class B tested & required
5	EN 55022 & CISPR 22 Conducted Emissions	Telecom Port	150 kHz to 30 MHz	Class B	Current & Voltage limits must be respected (EN55022 annex C, § C 1.2)
6	EN 55022 & CISPR 22 Radiated Emission	Enclosure of the EUT	30 MHz to 6 GHz	Class B	Tested with all RM at full power but don't take account GSM frequencies emissions

6. TEST CONFIGURATION

6.1. TEST CONFIGURATION FOR EMISSIONS TESTING

The BTS will be configured as close to normal intended use. The iBTS will be configured to transmit on all RF channels at Pmax on all the frequency band.
The hardware configuration will then be equivalent to a S33.

The Abis cable of the BTS is looped back at the end and a PCM signal is transmitted on this cable.

The following ports of the BTS will be available and connected :

- Abis port (telecom port) : cable 120Ω. This cable will be looped in order to transmit TX signals on RX ones.
- Alarms externs ports: 1 cable will be looped and the other cable will be in open circuit.
- Radio port (signal port) : all RF cables RADIALL SHF9TD – DC-2GHz – Insertion loss < 5.5 dB at 2 GHz (15 meters). Attenuators and loads will also be used on RF links.
- AC or DC Power port : Lab cables (about 10 meters).

Figure N°1: Emissions testing configuration

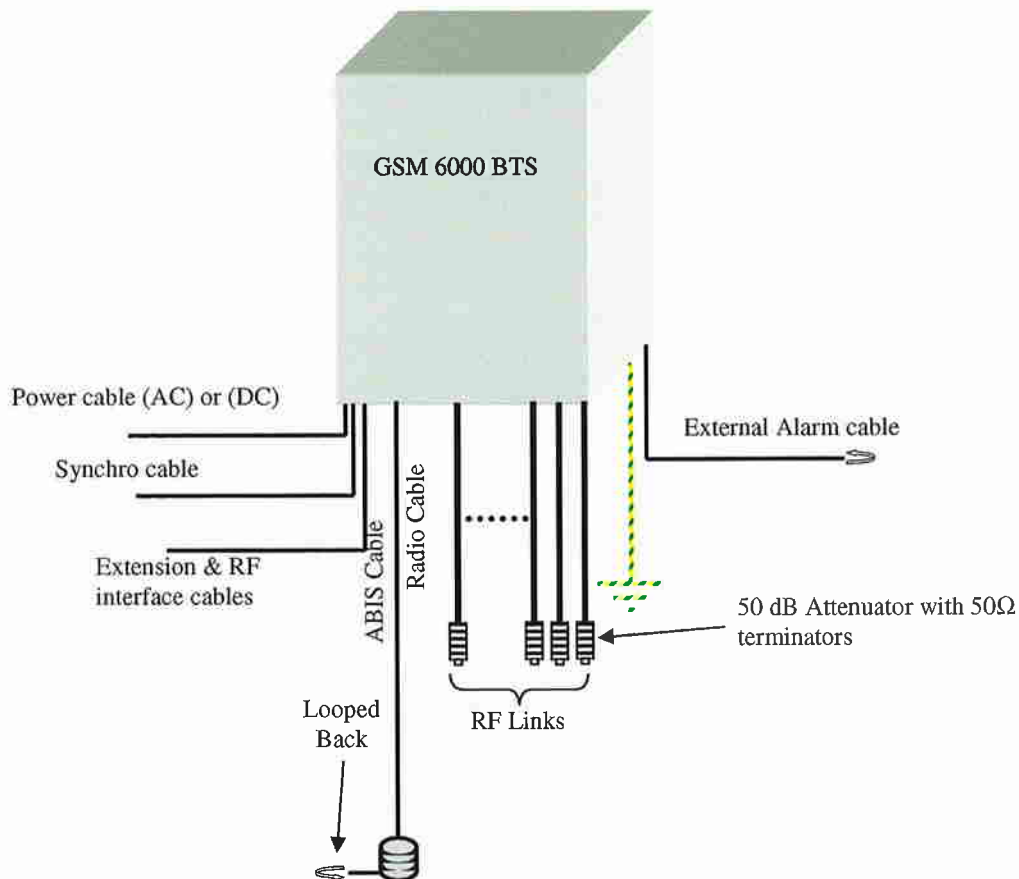



7. ABBREVIATIONS AND DEFINITIONS

7.1. ABBREVIATIONS

7.1.1 GENERAL ABBREVIATIONS

°C	Degree Centigrade
3GPP	3 rd Generation Partnership Project
A	Ampere
AC	Alternative Current (Power Source)
ADU	AC Distribution Unit
ALPRO	Alarm Protection
ANSI	American National Standards Institute
BTS	Base Station Transceiver Subsystem or Base Transceiver Station
CFR	Code of Federal Regulations
CSA	Canadian Standards Association
dB	Decibel
dB(A)	Decibel Audio
DC	Direct Current (Power Source)
E1	European Standard For PCM Link Interface (2.048mbit/S)
ECU	Environmental Control Unit
EDGE	Enhanced Data rates for GSM Evolution
EGPRS	Enhanced General Packet Radio Service (cf. EDGE)
EMC	Electro-Magnetic Compatibility
ETS	European Telecommunication Standard
ETSI	European Telecommunication Standard Institute
EVM	Error Vector Magnitude
FCC	Federal Communications Commission
GHz	Giga Hertz
GND	This Ground Represents Earth-Grounding Connection From Equipment
HW	Hardware
Hz	Hertz
IEC	International Electro-Technical Commission
IC	Industry Canada
ISO	International Standards Organization
IUT	International Telecommunication Union
kbits/s	Kilo Bits Per Second
LVD	Low Voltage Directive
MCPA	Multi-Carrier Power Amplifier
MHz	Mega-Hertz
N.A.	Not Applicable
NEMA	National Electrical Manufacturers Association (USA)



PA	Power Amplifier
PCM	Pulse Code Modulation
PCS	Personal Communication Service
PI	Product Integrity
R&D	Research and Development
RF	Radio Frequency
RSS	Radio Standard Specification
RTTE	Radio And Telecommunication Terminal Equipment
RX	Receiver
SELV	Safety Extra Low Voltage
T°	Temperature
T1	US Standard For PCM Interface (1.544mbps)
T1 PCM	Pulse Code Modulation at 1.544 MHz
TBC	To Be Confirmed
TBD	To Be Defined
TIA/EIA/IS	Telecommunication Industry Association / Electronic Industries Alliance /
TNV	Telecommunication Network Voltage Circuit
TX	Transmitter
UL	Underwriters Laboratories Inc.
V	Volt (Vdc with DC) or (Vac with AC)
VSWR	Voltage Standing Wave Ratio
W	Watt

7.1.2 GSM ABBREVIATIONS

ABM	Alarm And Bridge Module
AC	Alternative Current (Power Source)
ADU	AC Distribution Unit
ALPRO	Alarm Protection
CSU	Channel Service Unit
DBP	Digital Back Panel
DCS	Digital Cellular System
DDM	Dual Duplexer Module
ECU	Environmental Control Unit
EDGE	Enhanced Data rates for GSM Evolution
GSM	Global System For Mobile Communication
H2D	Hybrid Duplexer Two Paths
H3	Coupling Module Handling Up To 3 TX TDMA
H3D	Hybrid Duplexer Three Paths
H4M	PCM Clock At 4.096 MHz
HPRM	High Power Radio Module
IBP	Interface Back Panel
ICM	Interface Control Module
IFM	Interface Module Dedicated To PCM Link within a BTS 18000
LAPD	Link Access Protocol On The D Channel
PCS	Personal Communication Service
PRIPRO	Primary Protection



RICO	Radio Inter-Connection For Cabinet And Coupling Modules
RM	Radio Module
RMPSU	Radio Module Power Supply Unit
RXLEV	Reception Level
RXQUAL	Reception quality
S8000/S12000	This Represents The Previous GSM BTS Family (S8000 And S12000)
SICS	Snew Integrated Cooling System
SPM	Spare Module
SPU	Signal Processing Unit
TXF	Transmitter filter
UCPS	Univity Compact Power System
User ICO	User Interconnection



7.2. DEFINITIONS

Air discharge method : a method of testing, in which the charged electrode of the test generator is brought close to the EUT, and the discharge actuated by a spark to the EUT.

Amplitude modulation : process by which the amplitude of a carrier wave is varied following a specified law.

Anechoic chamber : shielded enclosure which is lined with radio-frequency absorbers to reduce reflections from the internal surfaces.

Antenna : transducer which either emits radio-frequency power into space from a signal source or intercepts an arriving electromagnetic field, converting it into an electrical signal.

Antistatic material : material exhibiting properties which minimize charge generation when rubbed against or separated from the same or other similar materials.

Artificial hand : an electrical network simulating the impedance of the human body under average operational conditions between a hand-held electrical appliance and earth

Auxiliary equipment : equipment necessary to provide the EUT with the signals required for normal operation and equipment to verify the performance of the equipment under test.

Balanced lines : a pair of symmetrically driven conductors with a conversion loss from differential to common mode of less than 20 dB.

Balun : device for transforming an unbalanced voltage to a balanced voltage or vice versa.

Burst : a sequence of a limited number of distinct pulses or an oscillation of limited duration.

Contact discharge method : a method of testing, in which the electrode of the test generator is held in contact with the EUT, and the discharge actuated by the discharge switch within the generator.

Clamp injection : clamp injection is obtained by means of a clamp-on "current" injecting device on the cable.

Continuous waves : electromagnetic waves, the successive oscillations of which are identical under steady-state conditions, which can be interrupted or modulated to convey information.

Coupling clamp : device of defined dimensions and characteristics for common mode coupling of the disturbance signal to the circuit under test without any galvanic connection to it.

Coupling network : electrical circuit for the purpose of preventing EFT voltage applied to the EUT from affecting other devices, equipment or systems which are not under test.

Coupling plane : a metal sheet or plate, to which discharges are applied to simulate electrostatic discharge to objects adjacent to the EUT.

Current clamp : a transformer, the secondary winding of which consists of the cable into which the injection is made.

Current surge : the front time T_f of a surge voltage is a virtual parameter defined as 1.25 times the interval T between the instants when the impulse is 10% and 90% of the peak value.

Decoupling network : electrical circuit for the purpose of preventing surges applied to the EUT from affecting other devices, equipment or systems which are not under test.



Degradation of performance : an undesired departure in the operational performance of any device, equipment or system from its intended performance.

Direct application : application of the discharge directly to the EUT.

Duration : the absolute value of the interval during which a specified waveform or feature exists or continues.

Electrical installation : an assembly of associated electrical equipment to fulfil a specific purpose or purposes and having coordinated characteristics.

Electromagnetic clamp : (EM-clamp) injection devices with combined capacitive and inductive coupling.

Electromagnetic compatibility : the ability of an equipment or system to function satisfactorily in its electromagnetic environment without introducing intolerable electromagnetic disturbances to anything in that environment.

Electromagnetic wave : radiant energy produced by the oscillation of an electric charge characterized by oscillation of the electric and magnetic field.

Electrostatic discharge : a transfer of electric charge between bodies of different electrostatic potential in proximity or through direct contact.

Energy storage capacitor : the capacitor of the ESD generator representing the capacity of a human body charged to the test voltage value. This may be provided as a discrete component, or a distributed capacitance.

Far field : region where the power flux density from an antenna approximately obeys an inverse square law of the distance.

Field strength : the term "field strength" is applied only to measurements made in the far field. The measurement may be of either the electric or the magnetic component of the field and may be expressed as V/m, A/m or W/m²; any one of these may be converted into the others.

Frequency band : continuous of frequencies extending between two limits.

Fully anechoic chamber : shielded enclosure whose internal surfaces are totally lined with anechoic material.

Ground reference plane : a flat conductive surface whose potential is used as a common reference

Holding time : interval of time within the decrease of the test voltage due to leakage, prior to the discharge, is not greater than 10%.

Human body-mounted equipment : equipment which is intended for use when attached to the human body. This definition included hand-held devices which are carried by people while in operation (e.g. pocket devices) as well as electronics aid devices and implants.

Immunity to a disturbance : the ability of a device, equipment or system to perform without degradation in the presence of an electromagnetic disturbance.

Indirect application : application of the discharge to a coupling plane in the vicinity of the EUT, and simulation of personnel discharge to objects which are adjacent to the EUT.

Induction field : predominant electric and/or magnetic field existing at a distance $d < \lambda/2\pi$, where λ is the wavelength and the physical dimensions of the source are much smaller than distance d .



Isotropic : having properties of equal values in all directions

Malfunction : the termination of the ability of an equipment to carry out intended functions or the execution of unintended functions by the equipment.

Maximum RMS value : the highest short-term RMS value of a modulated RF signal during an observation time of one modulation period. The short-term RMS is evaluated over a single carrier cycle.

Modified semi-anechoic chamber : semi-anechoic chamber which has additional absorbers installed on the ground plane.

Non-constant envelope modulation : RF modulation schemes where the amplitude of the carrier wave varies slowly in time compared with the period of the carrier itself. Examples include conventional modulation and TDMA.

Polarization : orientation of the electric field vector of a radiated field.

Port : particular interface of the EUT with the external electromagnetic environment

Primary protection : the means by which the majority of stressful energy is prevented from propagating beyond the designated interface.

Rise time : the interval of time between the instants at which the instantaneous value of a pulse first reaches 10% value and then the 90% values.

Secondary protection : the means by which the let-through energy from primary protection is suppressed. It may be a special device or an inherent characteristic of the EUT.

Semi-anechoic chamber : shielded enclosure where all internal surfaces are covered with anechoic material with the exception of the floor, which shall be reflective (ground plane).

Shielded enclosure : screened or solid metal housing designed expressly for the purpose of isolating the internal from the external electromagnetic environment. The purpose is to prevent outside ambient electromagnetic fields from causing performance degradation and to prevent emission from causing interference to outside activities.

Short interruption : the disappearance of the supply voltage for a period of time typically not exceeding 1 min. Short interruptions can be considered as voltage dips with 100% amplitude.

Spurious radiation : any undesired electromagnetic emission from an electrical device.

Stripline : terminated transmission line consisting of two parallel plates between which a wave is propagated in the transverse electromagnetic mode to produce a specified field for testing purposes.

Surge : a transient wave of electrical current, voltage, or power propagating along a line or a circuit and characterized by a rapid increase followed by a slower decrease.

Surge voltage : the front time T_f of a surge voltage is a virtual parameter defined as 1.67 times the interval T between the instants when the impulse is 30% and 90% of the peak value.

Sweep : continuous or incremental traverse over a range of frequencies

System : set of interdependent elements constituted to achieve a given objective by performing a specified function.



Time to half-value T_2 : the time to half value T_2 of a surge is a virtual parameter defined as the time interval between the virtual origin O_1 and the instant when the voltage current has decreased to half the peak value.

Transceiver : Combination of radio transmitting and receiving equipment in a common housing.

Transient : pertaining to or designating a phenomenon or a quantity which varies between two consecutive steady states during a time interval which is short compared with the time-scale of interest.

Voltage dips : a sudden reduction of the voltage at a point in the electrical system, followed recovery after a short period of time, from half a cycle to a few second.

Voltage variation : a gradual change of the supply voltage to a higher or lower value than the rated voltage. The duration of the change can be short or long with regard to the period.

❧END OF DOCUMENT❧



LABORATOIRE CENTRAL
DES INDUSTRIES ELECTRIQUES
RELATED DOCUMENT
to test report N° 60056565-5573082.
5 pages

GSM 6000 outdoor BTS 850MHz hardware delivery notice

Document number: PE/BTS/DJD/022074
Document issue: 02.01 / EN
Document status: Standard
Date: 02/MAY/2007

External document

Copyright® 2007 Nortel Networks, All Rights Reserved

Printed in France

NORTEL CONFIDENTIAL

The information contained in this document is the property of Nortel Networks. Except as specifically authorized in writing by Nortel Networks, the holder of this document shall keep the information contained herein confidential and shall protect same in whole or in part from disclosure and dissemination to third parties and use same for evaluation, operation and maintenance purposes only.

The content of this document is provided for information purposes only and is subject to modification. It does not constitute any representation or warranty from Nortel Networks as to the content or accuracy of the information contained herein, including but not limited to the suitability and performances of the product or its intended application.

This is the Way. This is Nortel, Nortel, the Nortel logo, and the Globemark are trademarks of Nortel Networks. All other trademarks are the property of their owners.

PUBLICATION HISTORY

02/MAY/2007

Issue 02.01 / EN, Standard

Delivery of the DC version of the GSM850Mhz Outdoor BTS 6000 – N°445082

18/APR/2007

Issue 01.01 / EN, Standard

Delivery of the AC version of the GSM850Mhz Outdoor BTS 6000 – N°434137

Introduction of Rectifier 1.4Kw CR

GSM 6000 outdoor BTS 850MHz hardware delivery notice

AVLM Recipient: LCIE	Date of delivery: 11/MAY/2007
Product: GSM 6000 Outdoor BTS	
Article delivered: DC version of GSM 6000 Outdoor BTS	Article code: NTQ610AA D1
Section transmitting: 8U00	Designer name: Chenet Stéphane
Cabinet Serial Number: NNTMGT004R9N / 445082	
Documents related to the Hardware Design Specifications - PE/BTS/DD/016672 V01.05/EN BTS 6000 Product Specification	
Documents dealing with specifications:	
Issues fixed on the cabinet:	
Missing Equipment: - Antennas cables from output of DDM to bulkhead are missing ; Use antennas cables from the BTS 6000 AC previously delivered.	
Software compatibility: Modules software version : - Load BTS : v15f1e04 / CDI118000 > ICM/ABM : v15f104 / CDI117970 > RM : v15e403 / CDI117006 PI software tools : - WINTMI: v03d306 - TIL COAM: v15e403 - TIL Alarm: v15e402 - WINTOOL: v04b4e10	

GSM 6000 outdoor BTS 850MHz hardware delivery notice

The delivery includes :

ARTICLE	PEC code	Release	Serial number	Comment
CAB: PRECA	NTQ610AA	D1	NNTMGT004R9N	
FILLER RECTIFIER	NTW70351	01	ATSNZH056168	
FILLER RECTIFIER	NTW70351	01	ATSNZH056166	
UCPS CCU UMTS/GSM	NTUM44AF	01	ATSNZH085723	
DDU	NTN066AA	D1	ATSNZH096624	
DCU	NTQ666BA	01	ATSNZH125868	Input filter updated to be compliant to CLASSE B in CEM test
CRICO	NTQ620CA	D1	NNTMGT004KVO	
CECU	NTQ675JA	D1	NNTMGT004R9J	
CECU Control Board	NTQ629AA	01	NNTM75012345	
RICAM	NTN024AA	D1 MIR 2.5	FANTASTIX	ICM 0 : IP → 47.164.182.180 ICM 0 : IP → 47.164.182.181 ABM 0 : IP → 47.164.182.182
HPRM 3T 850	NTN050JA	D1	CDN200651001	IP 47.164.182.183 with new PSU CR NTN058AM 04 / ATSNZH155429 For Radio test
HPRM 3T 850	NTN050JA	D1	CDN200651004	IP 47.164.182.184 with new PSU CR NTN058AM 04 / ATSNZH155427
DDM 850 W/VSWR W/HYBRIDS ROHS	NTN063HA	D2	FICT0300213H	
DDM 850 W/VSWR W/HYBRIDS ROHS	NTN063HA	D2	FICT0300212F	
DDM 850 W/VSWR W/HYBRIDS ROHS	NTN063HA	D2	FICT0300212G	
CALPRO2	NTQ675CA	D1	NNTMGT004MHZ	
CUSER-ICO	NTQ650AA	D1	NNTMGT004L73	

GSM 6000 outdoor BTS 850MHz hardware delivery notice

Additional delivery:

ARTICLE	PEC code	Release	Serial number	Comment
DC Power cable				
PCM cable				
CPRIPRO2	NTQ675SA	D1	NNTMGT004MZ7	
External Alarm Cable				

Tests performed:

The following features have been tested:

- PCM on RICAM.
- Alarms from the BTS.

- Radio test :
 - TX part :
TX sequences for Testeditor validation for qualification.
 - RX part :
Quick Base/Base Loopback performed.

- Remarks:
For qualification the radio tests will be performed on the HPRM 0 / TDMA 0

Functional limits:

- Hardware Limitations :
None

- Software Limitations :
None

Documents related to the Hardware Test Specifications

Reference of the test specifications documents:

- PE/BTS/DJD/018118 V01.01/EN Hardware integration test specification for BTS 6000

Documents related to the Hardware Test Report

Reference of the test reports documents:

- N/A

❧ END OF DOCUMENT ❧

Nortel Networks confidential