



# Radio Compatibility Test Report

## Nortel Networks Reunion 28-08M BTR

Document issue: 1.0  
PI-00328-00

Security status: Proprietary

Date: October 30, 2000

**Keywords:** Reunion 28-08M BTR, FCC Part 101 radio regulatory requirements

**Abstract:** This report documents the measurements that the C-MAC Engineering Product Integrity group performed in order to demonstrate radio regulatory compliance to FCC Part 101 requirements.

**Author(s):** Horia Popovici

**Approved by:** Denis Lalonde

**Recommended by:** Real Perriard

**Funder:** Nortel Networks

**Project Leader:** David Levy

**External Project #:** 23649

**Internal Project #:** KP000117

© Copyright C-MAC Engineering, October 2000

This document is the property of C-MAC Engineering who owns the copyright therein. The information in this document is given in confidence and without the written consent of C-MAC Engineering by contract or otherwise the document must not be copied, reprinted, or reproduced in any material form either wholly or in part nor must the contents of the document or any method or technique available therefrom be disclosed to any third party.



## Distribution List

---

Copy No.	Name	Department	Location
1.	PI File	C-MAC PI	KAN
2.	Ron Oostlander	Nortel Networks RB21	WDLN2
3.	David Levy	C-MAC PI	KAN

## Executive Summary

This report documents the measurements performed by the C-MAC Engineering Product Integrity group on the Nortel Networks Reunion 28-08M BTR (TDMA Configuration) from September 12 to September 19, 2000 in order to demonstrate radio regulatory compliance to FCC Part 101 requirements.

## Release Control Record

---

<b>Issue No.</b>	<b>Reason for change</b>	<b>Date Issued</b>
1.0	Original	October 30, 2000

## CERTIFICATE OF COMPLIANCE

**Product Name:** Reunion 28-08M BTR  
**Model Identifier:** NTVG14CB

On the basis of measurements here reported on October 30, 2000, the above referenced equipment is verified as meeting the requirements of FCC Part 101 (Fixed Microwave Services), and FCC Part 2 (Maximum Output Power and Occupied Bandwidth) requirements. The Test data included in this report applies to the product titled herein manufactured by Nortel Networks.

**Certified by:**

**Denis Lalonde**  
C-MAC Engineering, Inc.  
21 Richardson Side Road  
Kanata, Ontario  
K2K 2C1  
Canada





## Table of Contents

---

<b>1. TEST AND RESULTS SUMMARY .....</b>	<b>1</b>
<b>2. REFERENCE DOCUMENTATION.....</b>	<b>2</b>
2.1. SPECIFICATIONS .....	2
2.2. STANDARDS .....	2
2.3. OTHER REFERENCE DOCUMENTATION.....	2
2.4. GLOSSARY OF ACRONYMS.....	2
<b>3. PRODUCT DESCRIPTION .....</b>	<b>2</b>
3.1. PRODUCT IDENTIFICATION .....	3
3.2. FUNCTIONAL DESCRIPTION .....	3
3.3. PRODUCT CONFIGURATION (EQUIPMENT UNDER TEST) .....	4
<b>4. GENERAL TEST CONDITIONS.....</b>	<b>5</b>
4.1. TEST FACILITY .....	5
4.2. CLIMATIC CONDITIONS .....	5
4.3. MEASUREMENT INSTRUMENTATION .....	5
<b>5. TEST RESULTS.....</b>	<b>6</b>
5.1. NAME OF TEST: MAXIMUM TRANSMIT POWER.....	6
5.2. NAME OF TEST: OCCUPIED BANDWIDTH.....	7
5.3. NAME OF TEST: RF SPECTRUM MASK.....	8
<b>6. TEST EQUIPMENT.....</b>	<b>9</b>
6.1. TEST CONFIGURATION .....	9
6.1. TEST EQUIPMENT LIST.....	9
<b>ANNEX A (NORTEL REUNION 28-08M BTR TEST PLOTS).....</b>	<b>10</b>
<b>ANNEX B (NORTEL REUNION 28-08M BTR TEST PLAN).....</b>	<b>13</b>

## List of Tables

---

Table 1-1: Test Case Summary.....	1
Table 3-1: Hardware descriptions.....	4
Table 6-1: Test equipment used.....	9

## List of Figures

---

Figure 3-1: Nortel Networks Reunion TDMA system.....	3
Figure 5-1: Spectrum Mask limit.....	8
Figure 6-1: Test Configuration for Tx Output Power, Tx Nominal Output Power.....	9
Figure 6-1: Test Configuration for Occupied Bandwidth and Spectrum Mask.....	9
Figure A-1 (2808M 01 0001).....	10
Figure A-2 (2808M 01 0002).....	10
Figure A-3 (2808M 01 0003).....	11
Figure A-4 (2808M 01 0004).....	11
Figure A-5 (2808M 01 0005).....	12
Figure A-6 (2808M 01 0006).....	12



# 1. Test and Results Summary

The system described in Section 3.0 meets the requirements FCC Part 101 and Part 2, Fixed Microwave Services (10-1-97 edition).

A summary of the test cases can be found in the following table.

**Table 1-1: Test Case Summary**

Parameter	C	NC	NT	NA	Notes
<b>Transmitter characteristics</b>					
Maximum output power (FCC Part 2.1046)	X				
Occupied Bandwidth (FCC Part 2.1049)	X				
RF spectrum mask (FCC Part 101.111)	X				
Tx Conducted Spurious emissions (FCC Part 101.111)				X	
Radiated Spurious emissions (FCC Part 101.111)				X	
Tx Frequency Stability (FCC Part 101.107)				X	
<b>Legend:</b>					
C: The parameter is compliant with the requirements					
NC: The parameter is not compliant with the requirements					
NT: The parameter is not tested					
NA: The test of this parameter is not applicable					
<b>Notes:</b>					
None					

## 2. Reference Documentation

### 2.1. Specifications

Not applicable.

### 2.2. Standards

1. FCC Rules for Radio Frequency Devices, Title 47 of the Code of Federal Regulations amended per FCC 89-103 (GEN. Docket No. 87-389). Part 2 and 101, U.S. Federal Communications Commission 1995.
2. ANSI C63.4-1992, Methods of Measurement of Radio-Noise Emission from Low-Voltage Electrical and Electronic Equipment in the Range of 9 kHz to 40 GHz, May 1992.

### 2.3. Other Reference Documentation

Not applicable.

### 2.4. Glossary of Acronyms

ATM	Asynchronous Transfer Mode
AWM	ATM Wireless Multiplexer
BER	Bit Error Rate
BRM	Broadband Radio Modem
BTR	Base Station Transceiver
CIM	Chassis Interface Module
CTR	Customer Premise Transceiver
NA	Not Applicable
NIU	Network Interface Unit
NNE	Network Node Equipment
RPE	Radio Power Extractor
RSM	Redundancy Switching Matrix
TDMA	Time Division Multiple Access
UGB	Upstream Gain Block

## 3. Product Description

### 3.1. Product Identification

The unit tested in this report consisted of a DC powered module (-48V). The product trade name is Reunion 28-08M BTR. This is a Reunion family product.

The model of this product is NTVG14CB.

The FCC ID of this product is AB6BTR2808M.

The emission designators tested are 7M0D7W (1 carrier) and 28M0D7W (4 carriers).

Manufacturer: Nortel Networks Canada Limited  
Calgary, Alberta  
Canada

No modifications were necessary in order to comply with requirements as detailed in FCC Part 101 requirements.

### 3.2. Functional Description

The Nortel Networks TDMA Reunion system is depicted in Fig. 3-1 and described in the text below.

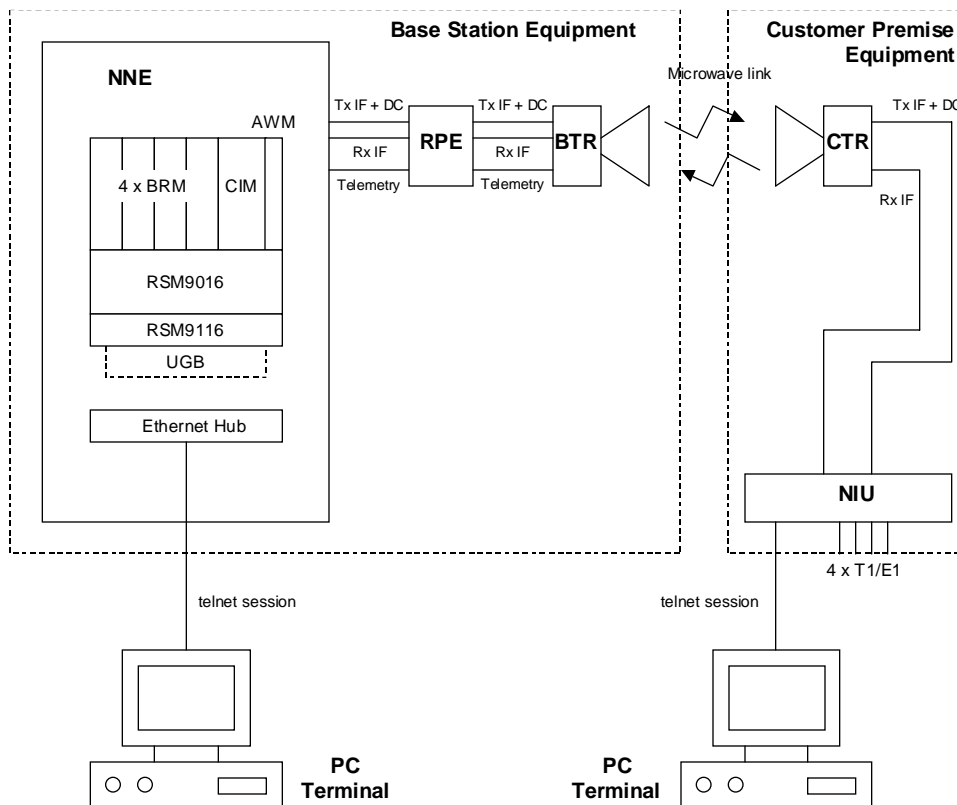

**Fig. 3-1: Nortel Networks Reunion TDMA system**

The Reunion Network Node Equipment (NNE) interfaces with the backbone ATM network. It also routes the ATM traffic to / from the Reunion Network Interface Units (NIU) located at the subscriber site through a set of modulators / demodulators. The BRM card contains one modulator and two demodulators. The BRM interfaces with the Reunion Base Station Transceivers (BTR) through the Redundancy Switching Matrix (RSM), which provides n : 1 redundancy switching for the BRM (RSM9016 for downstream and RSM9116 for upstream). The AWM provides a two-way interface to the network operator's ATM network through SONET / SDH link. The CIM controls the AWM and the output bit rate corresponding to the QAM modulation and symbol rate of the BRM. The RPE provides 1 : 1 redundancy switching for the base station transceiver. The UGB amplifies the upstream signal to compensate for the attenuation introduced by the RSM9116 Redundancy Switching Matrix.

The Customer Premise Equipment is a low cost unit that resides on the customer premises to provide a 10baseT Ethernet and four T1 / E1 connections. It can be connected to a variety of customer nodes that require any of aforementioned services. The unit consists of two major modules: the Network Interface Unit (NIU) and the Customer Premise Transceiver (CTR). The NIU is the indoor unit containing the TDMA modem and the interface to the network. The outdoor unit is a transceiver which converts the IF signals to / from the NIU to the required RF. These units are interconnected via coax cables that carries the IF signals and DC power for the CTR.

The software used during testing was representative of system performance under actual network usage conditions. Additional features required to activity and/or control specific radio functions (i.e. channel allocation, BER performance, power control) might be required as long as they are consistent with radio performance under actual network usage conditions.

### 3.3. Product Configuration (Equipment Under Test)

This system was configured with a TDMA chassis, a BTR, and the cables necessary to activate the hardware under investigation. Table 3-1 below provides a description of each component and the respective serial and model numbers.

**Table 3-1: Hardware descriptions**

	Product and Firmware description	Model No.	Serial No.
<b>EUT</b>	BTR	NTVG14CB	NNTM532GPH4X
<b>Support Equipment</b>	BRM5330	NTVH28AA	NNTM532LM2P4
	BRM5330	NTVH28AA	NNTM532LM2K0
	BRM5330	NTVH28AA	NNTM532LNYP2
	BRM5330	NTVH28AA	NNTM532LNHB8
	CIM5000C	NTVH25AA	NNTM5324MNJ3
	AWM5010B	NTVH04AA	NNTM535L4F5L
	D-Link Ethernet Hub	DE-809TP	HDCD001200
	RSM9016	NTVH13BA	NNTM532GA1LH
	RSM9116	NTVH20BA	NNTM532GD7NV
	UGB	NTVH29AB	NNTM53219QJN

## **4. General test conditions**

### **4.1. Test Facility**

Emission testing was performed in the C-MAC Engineering Product Integrity Radio Compatibility laboratory, located at 21 Richardson Side rd, Kanata, Ontario, Canada.

### **4.2. Climatic Conditions**

Climatic conditions are controlled within the following specifications:

- Ambient temperature: 15 to 25 deg. C
- Relative humidity: 20 to 50 %

### **4.3. Measurement Instrumentation**

Calibration of the measurement instrumentation is maintained in accordance with the supplier's recommendations, or as necessary to ensure its accuracy as per ISO 25 requirements.

## 5. Test Results

### 5.1. Name of Test: Maximum Transmit Power

#### 5.1.1. Test Procedure

As per FCC Part 2.1046

The maximum transmit power was measured using the average power detector on a power meter.

#### 5.1.2. Test Results

Ambient Temperature: 15 to 25 deg. C

Relative Humidity: 20 to 50 %

Test Conditions: Nominal temperature, Nominal Power Supply Voltage

Number of Carriers	Transmitter Power Level (dBm)		
	Channel B 27.5035 GHz	Channel M 27.5750 GHz	Channel T 27.6465 GHz
1	20.0	19.9	19.9
4	17.7	17.7	17.9

The equipment complies with the limits.

#### 5.1.3. Limits

Authorized Power (dBm) as quoted on Form 731	20.0 dBm (1 carrier) 17.5 dBm (4 carriers)
---	---

Test Equipment Used	1, 2, 3, 4, 5 (see Table 6-1)
---------------------	-------------------------------

## 5.2. Name of Test: Occupied Bandwidth

### 5.2.1. Test Procedure

As per FCC Part 2.1049

### 5.2.2. Test Results

Ambient Temperature: 15 to 25 deg. C

Relative Humidity: 20 to 50 %

Test Conditions: Nominal temperature, Nominal Power Supply Voltage

Number of Carriers	Occupied Bandwidth
	Channel M 27.5750 GHz
1	6.033 MHz (Plot: 2808M 01 0001)
4	26.83 MHz (Plot: 2808M 01 0002)

Test Equipment Used	4, 5, 6 (see Table 6-1)
---------------------	-------------------------

## 5.3. Name of Test: RF Spectrum Mask

### 5.3.1. Test Procedure

As per FCC Part 101.111 a)

This measurement was performed using a spectrum analyzer with 1 MHz resolution bandwidth.

### 5.3.2. Test Results

Ambient Temperature: 15 to 25 deg. C

Relative Humidity: 20 to 50 %

Number of Carriers	RF Spectrum Mask Results – 1/4 TDMA carrier(s)	
	Channel B 27.5035 GHz	Channel T 27.6465 GHz
1	Plot: 2808M 01 0003	Plot: 2808M 01 0004
4	Plot: 2808M 01 0005	Plot: 2808M 01 0006

The equipment complies with the limit.

### 5.3.3. Limits

Allowed Power Range (dBm)	Attenuation = $11 + 0.4(P - 50) + 10 \text{ Log}_{10} B$ . (Attenuation greater than 56 decibels is not required.)
---------------------------	---

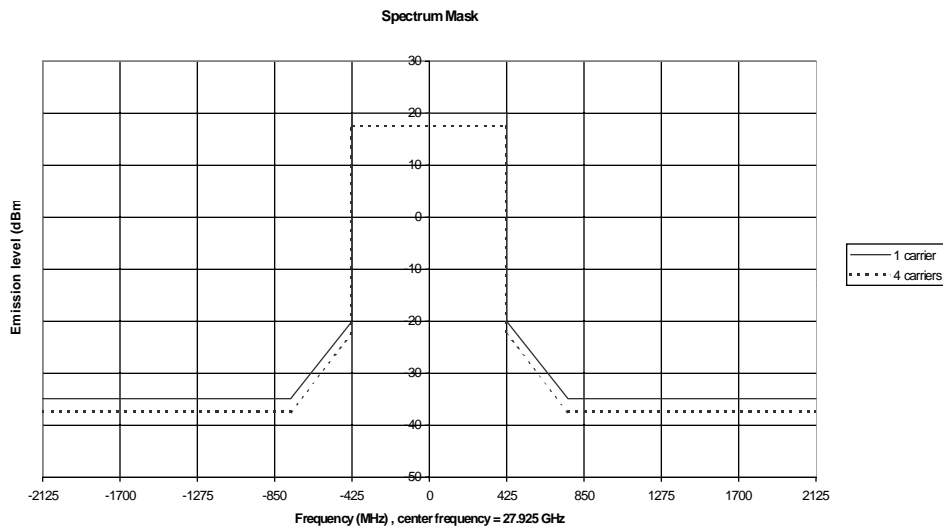

Fig. 5-1: Spectrum Mask limit

Test Equipment Used	1, 2, 3, 4, 5, 6 (see Table 6-1)
---------------------	----------------------------------



## 6. Test equipment

### 6.1. Test Configuration

The following figures describe the test configuration for the transmitter and receiver radio test cases.

**Fig. 6-1:** Test Configuration for Tx Output Power, Tx Nominal Output Power

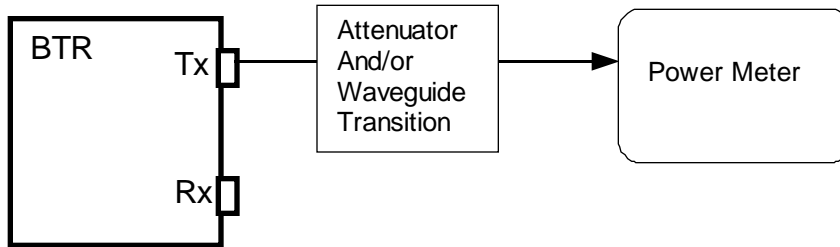

**Fig. 6-2:** Test Configuration for Occupied Bandwidth and Spectrum Mask

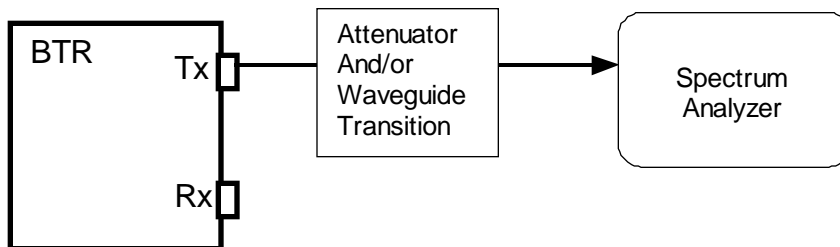

### 6.2. Test Equipment List

The following is a list of test equipment used to perform all tests described in this report:  
 All measurement equipment were within their respective calibration periods

**Table 6-1** Test equipment used

Item	Description	Make	Model #	Asset # Or Serial #	Cal. due date
1	Power Meter	Anritsu	ML2438A	98290019	10/00
2	Power Sensor	Anritsu	MA2424A	971397	09/00
3	RF Signal Generator	Wiltron	69369A	670022	NA
4	Coupler	PRD Electronics	A414-10FS1	111	NA
5	20dB coaxial K-type attenuator	Weinschel Corp	54-20	E6851	NA
6	Spectrum Analyzer	HP	8564E	Z0082288	11/00



## Annex A: Nortel Reunion 28-08M BTR Test Plots

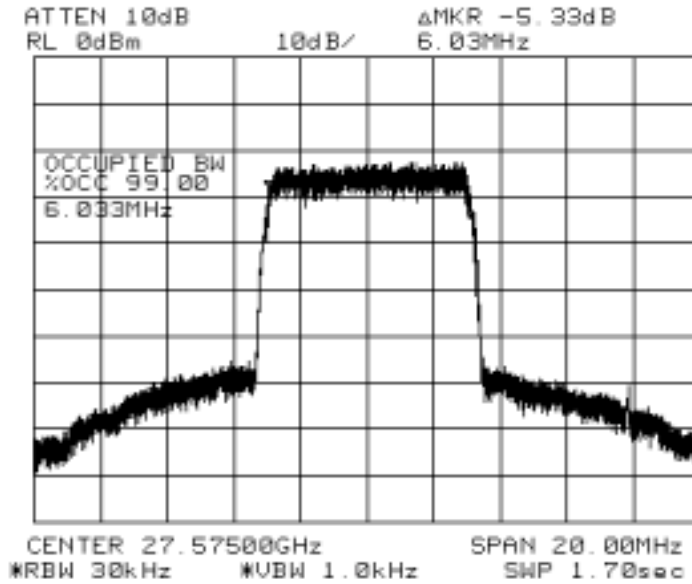

Fig. A-1 (2808M 01 0001: 1 carrier)

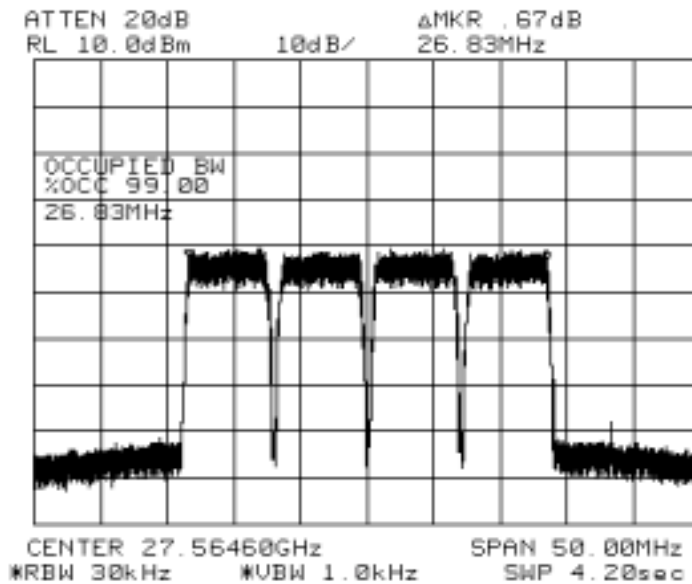

Fig. A-2 (2808M 01 0002: 4 carriers)

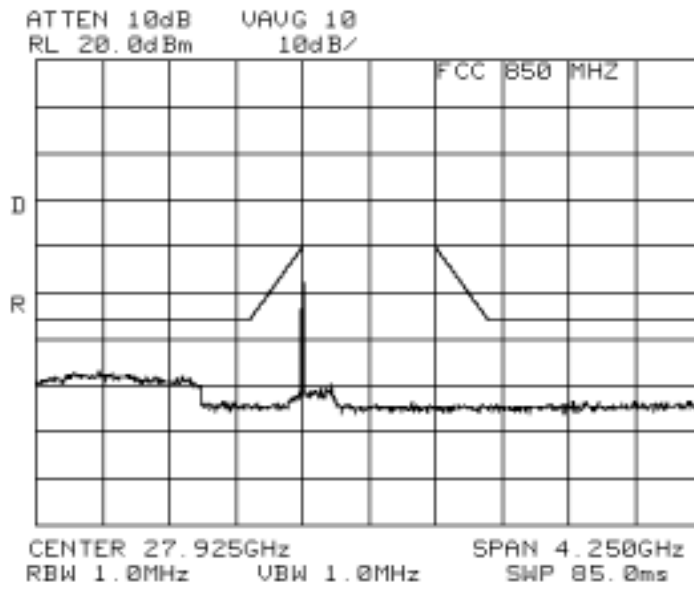

Fig. A-3 (2808M 01 0003: channel B, 1 carrier)

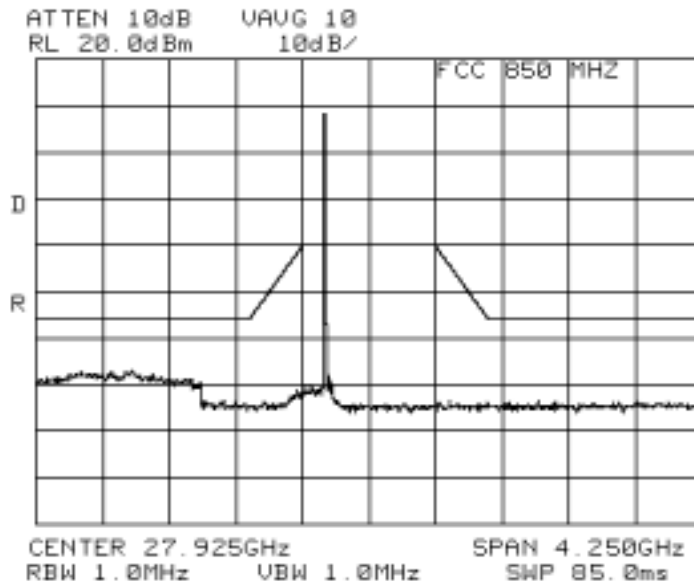

Fig. A-4 (2808M 01 0004: channel T, 1 carrier)

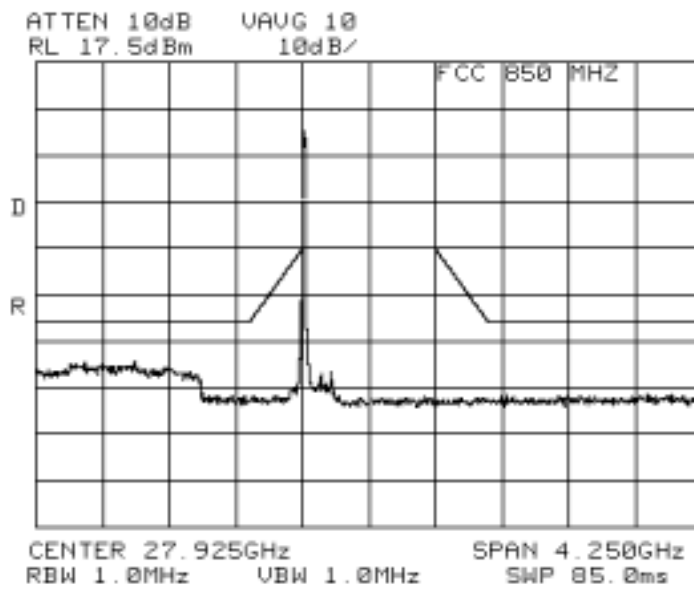

Fig. A-5 (2808M 01 0005: channel B, 4 carriers)

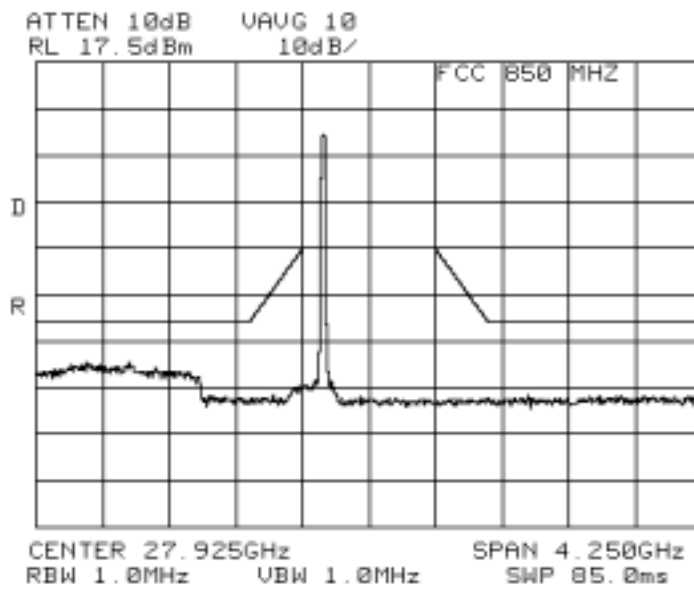

Fig. A-6 (2808M 01 0006: channel T, 4 carriers)

## Annex B: Nortel Reunion 28-08M BTR Test Plan

Authorized bandwidth: 850 MHz

BTR bandwidth capability: 150 MHz

Channel B: IF Tx: 646.5 MHz, RF Tx: 27.5035 GHz

Channel M: IF Tx: 575.0 MHz, RF Tx: 27.5750 GHz

Channel T: IF Tx: 503.5 MHz, RF Tx: 27.6465 GHz

Channel spacing: 7 MHz

Symbol rate: 5.913 Msymbols/sec

### Specified Output Power

16QAM

1 carrier: 20.0 dBm

4 carriers: 11.5 dBm

(These values are for individual carriers. In case of 4 carriers, the total power will be 6 dB higher)

### Transmitted Power

Frequencies: B, M, and T

Number of carriers: 1 and 4

### 99% Occupied Bandwidth

Frequencies: M

Number of carriers: 1 and 4

### Spectrum Mask

Frequencies: B and T

Number of carriers: 1 and 4

# **Reunion 28-08M BTR Radio Compatibility Test Plan**

## **END OF REPORT**

© Date: October 30, 2000 C-MAC Engineering  
All rights reserved