

REVISIONS		
REVISION	DESCRIPTION	DATE

Note 1: Correct certification numbers will be placed on products during mass production.
 Note 2: Japanese Technical Conformity mark sized to be 3.5mm.
 Minimum allowable size is 3mm as of September 1, 2014.
 Ref. http://www.dspr.co.jp/news_en/News_Information_20140901_Display_EN1.0.pdf

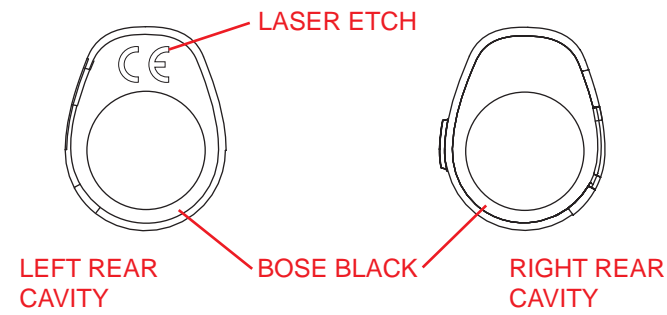
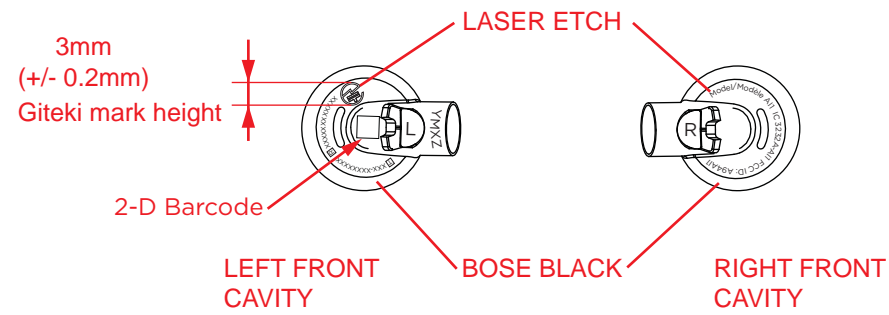

ICE SKU VARIANT 1 ARTWORK OVERVIEW

BOSE PART NUMBER	GRAPHIC ART MASTER NUMBER	GRAPHIC COLOR	BACKGROUND COLOR
773045-0010	AM773045 SHEET 1	LASER ETCHING	BOSE BLACK

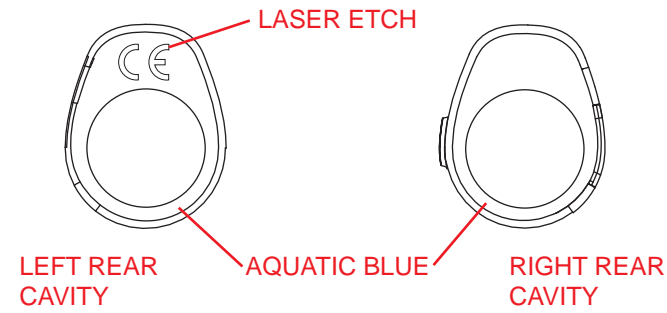
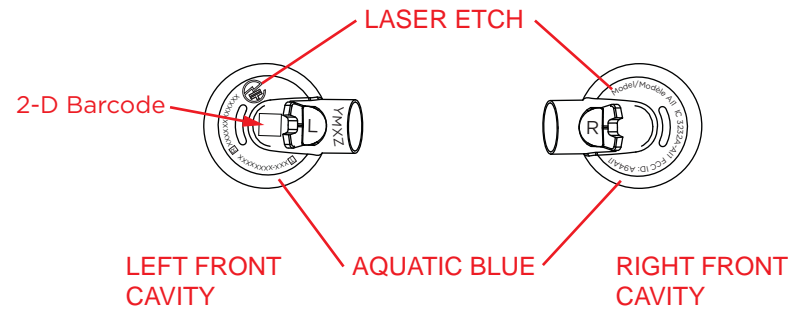

ICE SKU VARIANT 2 ARTWORK OVERVIEW

BOSE PART NUMBER	GRAPHIC ART MASTER NUMBER	GRAPHIC COLOR	BACKGROUND COLOR
773045-0020	AM773045 SHEET 2	LASER ETCHING	AQUATIC BLUE

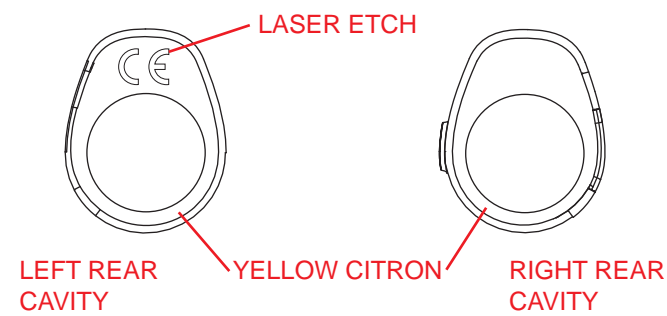
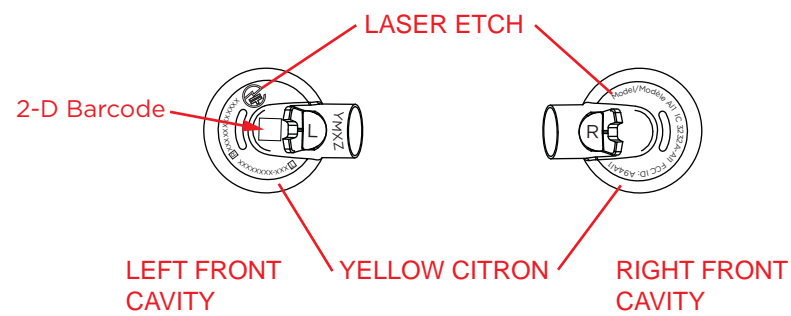

ICE SKU VARIANT 3 ARTWORK OVERVIEW

BOSE PART NUMBER	GRAPHIC ART MASTER NUMBER	GRAPHIC COLOR	BACKGROUND COLOR
773045-0030	AM773045 SHEET 3	LASER ETCHING	YELLOW CITRON

THIRD ANGLE PROJECTION

UNLESS OTHERWISE SPECIFIED INTERPRET THIS DRAWING PER ASME Y14.5M-1994

APPROVALS

ALL SIGNATURES ARE ELECTRONICALLY STORED IN THE BOSE PLM SYSTEM

NOTICE

BOSE CORP PROPRIETARY RIGHTS ARE INCLUDED HEREIN. THIS INFORMATION MAY NOT BE COPIED, TRANSFERRED OR DISCLOSED EXCEPT AS AUTHORIZED BY BOSE CORP

SAFETY CONTROLLED

BOSE[®]
FRAMINGHAM, MA 01701-9168

DESCRIPTION: **ICE FRONT AND REAR CAVITY**

SIZE	CAGE CODE	DOCUMENT NO.	REVISION
B	32108	GR773045	00

SCALE: 1 : 1 STATE SHEET 1 OF 2

REVISIONS		
REVISION	DESCRIPTION	DATE

ICE SKU JAPAN VARIANT 1 ARTWORK OVERVIEW

BOSE PART NUMBER	GRAPHIC ART MASTER NUMBER	GRAPHIC COLOR	BACKGROUND COLOR
773045-0040	AM773045 SHEET 4	LASER ETCHING	BOSE BLACK

ICE SKU JAPAN VARIANT 2 ARTWORK OVERVIEW

BOSE PART NUMBER	GRAPHIC ART MASTER NUMBER	GRAPHIC COLOR	BACKGROUND COLOR
773045-0050	AM773045 SHEET 5	LASER ETCHING	AQUATIC BLUE

ICE SKU JAPAN VARIANT 3 ARTWORK OVERVIEW

BOSE PART NUMBER	GRAPHIC ART MASTER NUMBER	GRAPHIC COLOR	BACKGROUND COLOR
773045-0060	AM773045 SHEET 6	LASER ETCHING	YELLOW CITRON

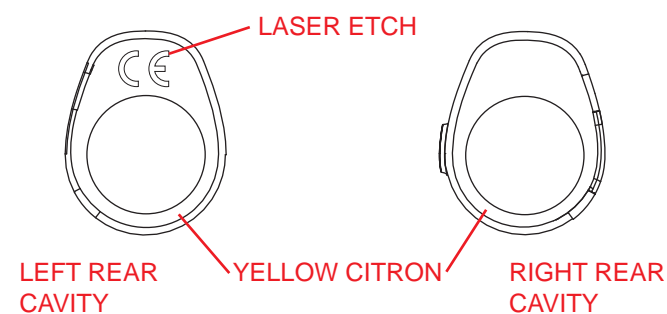
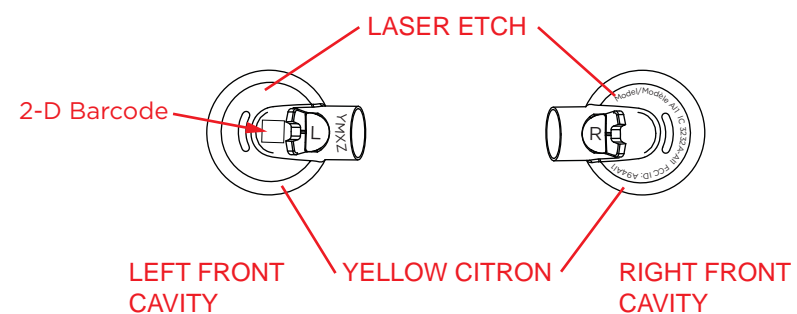
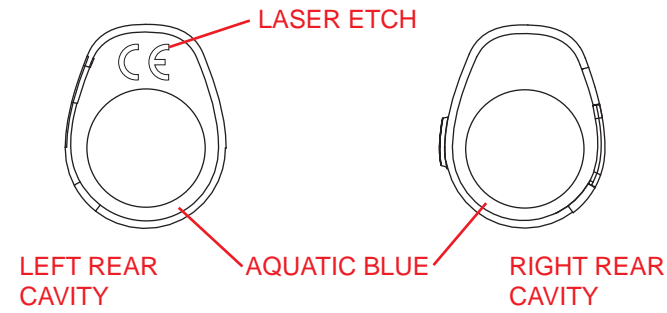
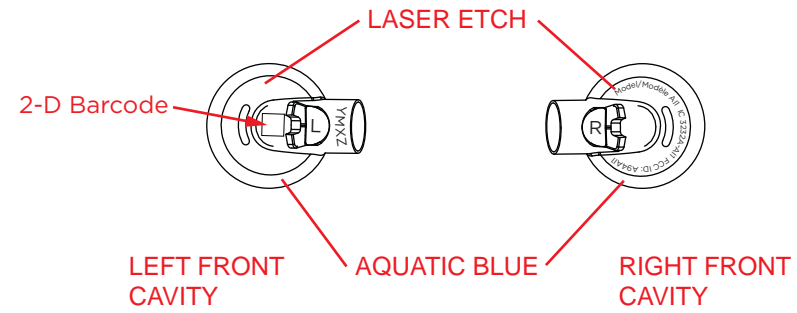
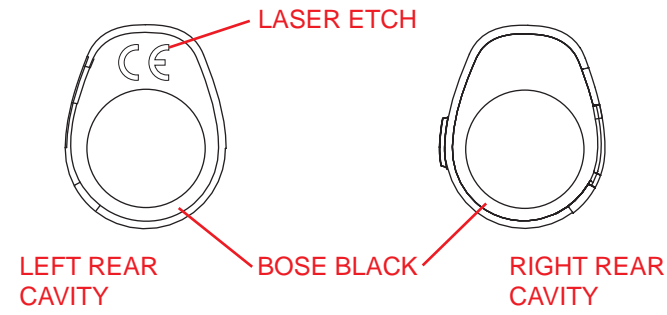
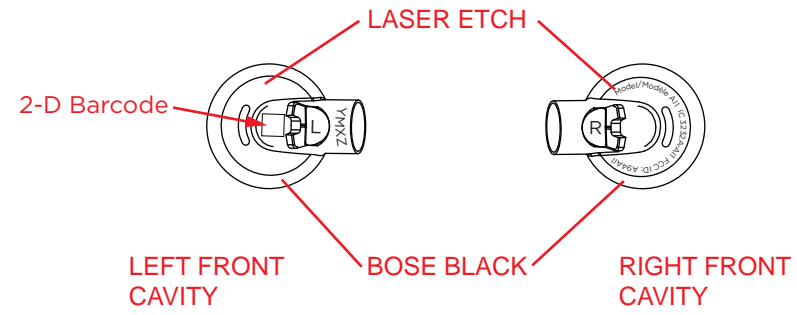

THIRD ANGLE PROJECTION

UNLESS OTHERWISE SPECIFIED INTERPRET THIS DRAWING PER ASME Y14.5M-1994

APPROVALS

ALL SIGNATURES ARE ELECTRONICALLY STORED IN THE BOSE PLM SYSTEM

NOTICE

BOSE CORP PROPRIETARY RIGHTS ARE INCLUDED HEREIN. THIS INFORMATION MAY NOT BE COPIED, TRANSFERRED OR DISCLOSED EXCEPT AS AUTHORIZED BY BOSE CORP

SAFETY CONTROLLED

BOSE[®]
FRAMINGHAM, MA 01701-9168

DESCRIPTION: **ICE FRONT AND REAR CAVITY**

SIZE	CAGE CODE	DOCUMENT NO.	REVISION
B	32108	GR773045	00

SCALE: 1 : 1 STATE SHEET 2 OF 2