



Wireless Transceiver Test Report



FCC ID:A94328040

IC ID:3232A-328040

Certificate # 1514.1

Report number: EMC.406968.11.158.1

Prepared for: Bose Corporation
DCE - EMC
1 New York Ave, Framingham MA 01701

Product Tested: Bose Model 328040

Standards: FCC part 15, RSS210, RSS-gen and ICES-003

Report prepared by: Brent DeWitt

Signature: 

Report reviewed by: Bryan Cerqua

Signature: 

Report issue date: June 28, 2011 revision 2

Changes from previous revision: OWB and output power revised

Without written permission of laboratory, this report shall not be reproduced except in full.



Wireless Transceiver Test Report



FCC ID:A94328040

IC ID:3232A-328040

Certificate # 1514.1

Table of Contents

1. Report Summary.....	3
2. Product description	4
3. Applicable standards, requirements and tests.....	5
4 Environmental Conditions.....	6
5. EUT configuration.....	6
6. Detailed Test Results.....	7
6.1. Conducted emissions.....	7
6.2. Radiated emissions 30 MHz – 1 GHz.....	11
6.3. Output power	15
6.4. Occupied Bandwidth/Channel Spacing	17
6.5. Time of occupancy	22
6.6. Power Spectral Density	24
6.7. Spurious emissions	25
6.8. Harmonics	28
6.9. Spurious emissions 1-25 GHz.....	32
6.10. Receiver spurious emissions.....	50
6.11. MPE calculation.....	52

Without written permission of laboratory, this report shall not be reproduced except in full.



Wireless Transceiver Test Report



FCC ID:A94328040

IC ID:3232A-328040

Certificate # 1514.1

1. Report Summary

1.1 Product Model 328040

1.2 Client Bose Corporation
The Mountain, Framingham MA 01701

1.3 Applicable Standards **FCC part 15.B and C**
RSS-210 issue 8
RSS-Gen issue 3
ICES-003 issue 4

Test Results: Pass Fail

1.4 Test Laboratory Bose DCE laboratories
1 New York Ave
Framingham, MA 01701.
IC registration : 3232A
FCC site registration under A2LA cert. #1514

This report relates only to the items tested.

Without written permission of laboratory, this report shall not be reproduced except in full.



Wireless Transceiver Test Report



FCC ID:A94328040

IC ID:3232A-328040

Certificate # 1514.1

2. Product description

The Model 328040 is a powered speaker array with wireless connection to a companion powered speaker, Model 329009 using Digital Modulation/Frequency Hopping hybrid operation.

The Model 328040 is the master in a master slave communications system and acts as a radio frequency data source.

Without written permission of laboratory, this report shall not be reproduced except in full.



Wireless Transceiver Test Report



FCC ID:A94328040

IC ID:3232A-328040

Certificate # 1514.1

3. Applicable standards, requirements and tests

FCC part 15	RSS210	RSS-gen	Test references.	Result / Data section
15.15(b)		5.3	There are no user-accessible controls for the adjustment of any transmitter parameters in the device under test.	Complies
15.27			There are no special devices such as shielded cables or special connectors required for compliance to the applicable standards.	Complies
15.203			An intentional radiator shall be designed to ensure that no antenna other than that furnished by the responsible party shall be used with the device. The antenna is not accessible by the user.	Complies
15.205	2.2		The device does not operate in either the US or Canadian restricted bands.	Complies
15.107 15.207		7.2.2	Conducted emissions, 150kHz–30 MHz	Section 6.1
15.109 15.209			Radiated emissions, 30MHz–1GHz Spurious emissions, 30MHz–1GHz	Section 6.2
15.247 (b)(1)	A8.4 (4)		Transmitter output power:	Section 6.3
15.247 (a)(1)	A8.1 (b)		DMS Occupied Bandwidth / channel spacing	Section 6.4
15.247(a) (1) iii	A8.3 (1)		Time occupancy of a frequency hopper.	Section 6.5
15.247(d)	7.2.3		Transmitter conducted spurious emissions	Section 6.6
15.247(d)			Transmitter harmonics.	Section 6.7
15.247(d)	2.2(b)		Transmitted radiated spurious emissions	Section 6.8
	6(b)	7.2.3	Receiver Spurious emissions	Section 6.9
OET65	Canada Health and Safety code 6		MPE calculation	6.10

Without written permission of laboratory, this report shall not be reproduced except in full.



Wireless Transceiver Test Report



FCC ID:A94328040

IC ID:3232A-328040

Certificate # 1514.1

4 Environmental Conditions

All testing is performed under the following conditions, unless otherwise defined in the detail test report section.

Temperature: 22 ± 4 °C

Humidity: 30 – 60 % RH

5. EUT configuration.

For the purposes of tests, the volume is adjusted for maximum emissions and then the remote control is removed from the test field. The remote control operates via infra-red transmission.

The 2.4 GHz data link can be placed into a number of test modes via a serial service port when specific EUT firmware is loaded to enable this test functionality.

Two options exist for the audio input; conventional analog and optical and a proprietary cable and connector system to an existing Bose product. The intentional radiator section is identical in each and the worst case data will be presented for conducted and radiated emissions.

Without written permission of laboratory, this report shall not be reproduced except in full.



Wireless Transceiver Test Report



FCC ID:A94328040

IC ID:3232A-328040

Certificate # 1514.1

6. Detailed Test Results.

6.1. Conducted emissions.

6.1.1. Requirements

47CFR15.207

Frequency MHz	Limits dB(μV)	
	Quasi-peak	Average
0.15 -0.5	66-56	56-46
0.5 – 1.6	56	46
1.6 – 30	60	50

6.1.2. Test setup details

The EUT was tested in accordance with ANSI C63.10 test setup conditions in a typical user configuration. The power supply switching frequency can be varied under software control and was tested at highest and lowest switching frequency.

6.1.3. Test data

Summary

Plot #1 & 2, 120V AC 60 Hz , Neutral and Line side

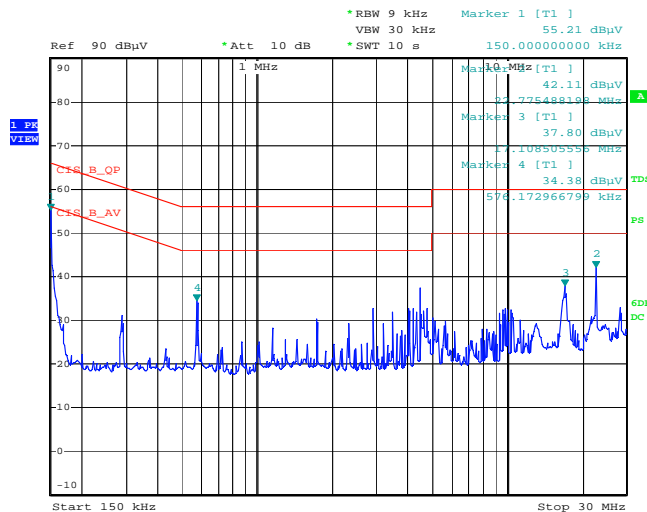

Date: 10.MAR.2011 10:23:31

Without written permission of laboratory, this report shall not be reproduced except in full.



Wireless Transceiver Test Report



FCC ID:A94328040

IC ID:3232A-328040

Certificate # 1514.1

Line

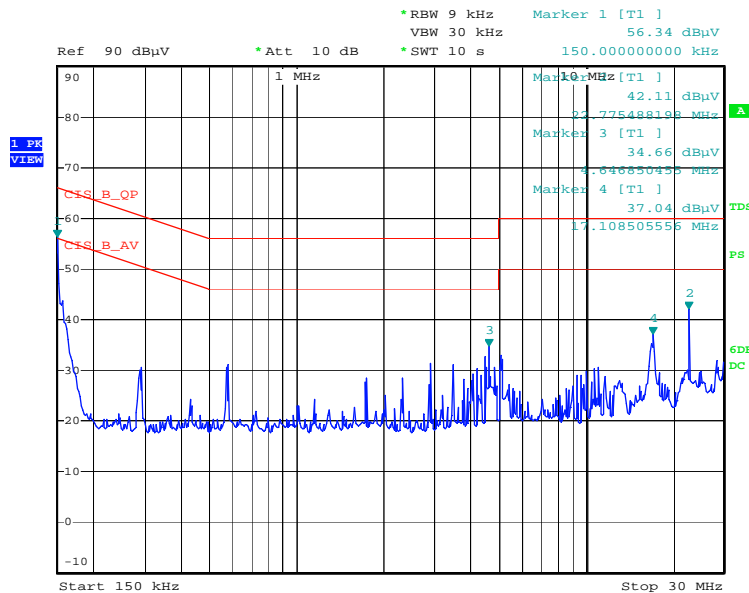

Date: 10.MAR.2011 10:19:10

Neutral

LINE – 120VAC, Max Volume Pink Noise, Power Supply Freq = 145.5kHz

Frequency MHz	MEASURED		LIMIT		MARGIN	
	dBµV QP	dBµV AVG	dBµV QP	dBµV AVG	dB QP	dB AVG
0.1500	51.30	39.80	66.0	56.0	14.7	16.2
22.6153	41.30	41.10	60.0	50.0	18.7	8.9
17.1386	34.00	28.20	60.0	50.0	26.0	21.8
0.5805	30.70	25.70	56.0	46.0	25.3	20.3
4.4912	29.10	22.20	56.0	46.0	26.9	23.8
2.9046	29.80	22.70	56.0	46.0	26.2	23.3

Without written permission of laboratory, this report shall not be reproduced except in full.



Wireless Transceiver Test Report



FCC ID:A94328040

IC ID:3232A-328040

Certificate # 1514.1

LINE – 120VAC, Max Volume Pink Noise, Power Supply Freq = 149.5kHz

Frequency MHz	MEASURED		LIMIT		MARGIN	
	dB μ V QP	dB μ V AVG	dB μ V QP	dB μ V AVG	dB QP	dB AVG
0.1500	53.10	43.90	66.0	56.0	12.9	12.1
22.6150	44.10	43.90	60.0	50.0	15.9	6.1

EUT passes CISPR13 limits with 6.1dB margin at 22.615MHz

NEUTRAL – 120VAC, Max-Peak Detector, 150kHz-30MHz, Max Volume Pink Noise

NEUTRAL – 120VAC, Max Volume Pink Noise, Power Supply Freq = 145.5kHz

Frequency MHz	MEASURED		LIMIT		MARGIN	
	dB μ V QP	dB μ V AVG	dB μ V QP	dB μ V AVG	dB QP	dB AVG
0.1500	51.50	39.80	66.0	56.0	14.5	16.2
22.6153	41.30	41.10	60.0	50.0	18.7	8.9
4.4918	28.70	21.80	56.0	46.0	27.3	24.2
17.1386	33.60	27.80	60.0	50.0	26.4	22.2
2.9046	28.40	21.70	56.0	46.0	27.6	24.3
0.5805	25.70	20.20	56.0	46.0	30.3	25.8

NEUTRAL – 120VAC, Max Volume Pink Noise, Power Supply Freq = 149.5kHz

Frequency MHz	MEASURED		LIMIT		MARGIN	
	dB μ V QP	dB μ V AVG	dB μ V QP	dB μ V AVG	dB QP	dB AVG
0.1500	53.50	42.60	66.0	56.0	12.5	13.4
22.6150	44.00	43.80	60.0	50.0	16.0	6.2

Neutral passes CISPR13 limits with 6.2dB margin at 22.615MHz

Without written permission of laboratory, this report shall not be reproduced except in full.



Wireless Transceiver Test Report



FCC ID:A94328040

IC ID:3232A-328040

Certificate # 1514.1

6.1.4. Test Equipment

Equipment Type	Manufacturer	Model	Serial or other ID	Service	
				Last	due date
LISN	EMCO	3810/2	TN600	3/11/2010	3/1/2012
Receiver	Rohde & Schwarz	ESCI	TN1420	4/5/2011	4/5/2012
LISN	Com-Power	LI-115	TN1777	6/3/2010	6/3/2011
Transient Limiter	HP	11947A	TN57	11/24/2009	11/24/2011

6.1.5. Test information

Date of test:	10 March 2011	Test location :	DCE lab – Henry room
EUT serial:	DP3-0548	Tested by:	Andrew Paradis
Test Conclusion:	pass		

Without written permission of laboratory, this report shall not be reproduced except in full.



Wireless Transceiver Test Report



FCC ID:A94328040

IC ID:3232A-328040

Certificate # 1514.1

6.2. Radiated emissions 30 MHz – 1 GHz

6.2.1. Requirements

FCC rules part 15.109 (g), 15.209 , RSS210 section 2.6, ICES-003 issue 4 (2004) and CAN/CSA-CEI/IEC CISPR 22:02

Frequency	Limit in dB μ V/m @3m
MHz	Quasi-peak
30 – 230	40
230 - 1000	47
Above 1000	54

6.2.2. Test setup details

The EUT was placed on an 80 cm high table and configured for worst case emissions based on previous testing. Data represents the worst case operating mode with the audio stream based on pink noise. Most of the data is associated with the FCC part 15.B attributes of the product.

Description of cables:

- 1) The Model 328040 Sound Bar was tested in conjunction with the companion Model 329009. In certain cases, an optional coaxial cable can be used to connect the two units. Testing was done in both modes and the worst case determined.
- 2) All input audio cables attach to the 328040 Sound Bar.

Without written permission of laboratory, this report shall not be reproduced except in full.



Wireless Transceiver Test Report



FCC ID:A94328040

IC ID:3232A-328040

Certificate # 1514.1

6.2.3. Test data

120VAC, Max-Hold Peak Pre-scan, Max Volume Pink noise

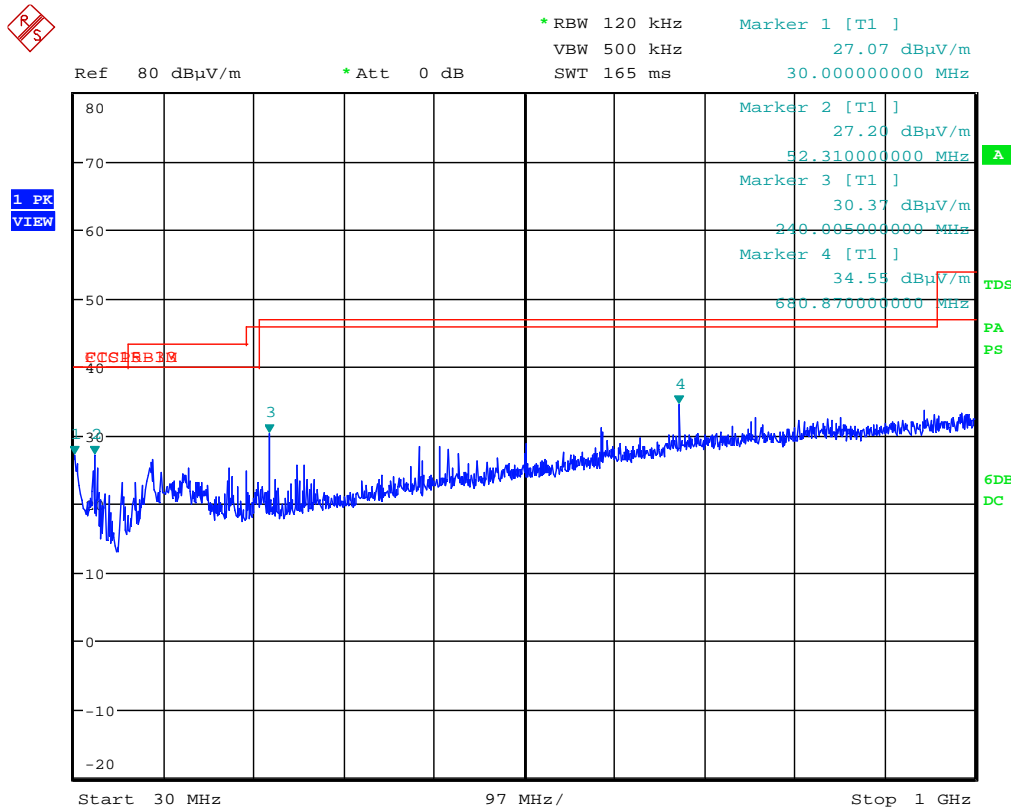

Date: 8.MAR.2011 23:30:58

Max Hold – Bass Box connected via RF cable at 120VAC/60Hz

FCC 15B Class B Product (Residential) @ 3 Meters										
Emission Frequency (MHz)	Measured Amplitude (dBµV/m) QP/AVG*	Measured Amplitude (dBµV/m) Peak	FCC 15B				Table Azimuth (0° closest to ant)	Receiving Antenna		*Average detector used for frequencies above 1 GHz.
			Limit (dBµV/m) QP/AVG*	Limit (dBµV/m) Peak	Margin (dB) QP/AVG*	Margin (dB) Peak		Pol (H/V)	Height (Meters)	
30.000	21.00	26.90	40.0	N/A	19.0	N/A	0	V	1.0	Bass Box connected via RF cable at 120VAC/60Hz
56.470	22.70	27.00	40.0	N/A	17.3	N/A	283	V	1.0	Bass Box connected via RF cable at 120VAC/60Hz
240.000	30.10	31.90	46.0	N/A	15.9	N/A	0	H	1.4	Bass Box connected via RF cable at 120VAC/60Hz
433.119	31.40	33.50	46.0	N/A	14.6	N/A	329	V	1.6	Bass Box connected via RF cable at 120VAC/60Hz
680.619	37.30	39.40	46.0	N/A	8.7	N/A	350	V	1.4	Bass Box connected via RF cable at 120VAC/60Hz
763.115	33.00	36.50	46.0	N/A	13.0	N/A	323	H	1.0	Bass Box connected via RF cable at 120VAC/60Hz

EUT passes FCC Class B Radiated Emissions with a margin of 8.7dB at 680.619MHz

Without written permission of laboratory, this report shall not be reproduced except in full.



Wireless Transceiver Test Report



FCC ID:A94328040

IC ID:3232A-328040

Certificate # 1514.1



1 PK
VIEW

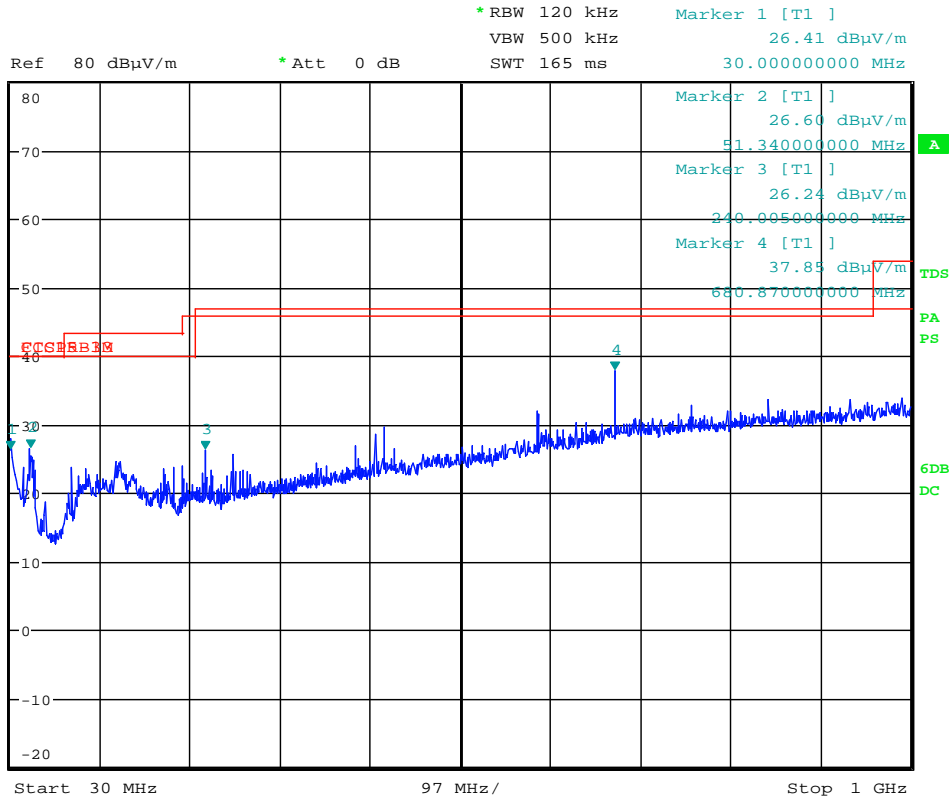

Date: 9.MAR.2011 00:01:02

Max Hold – Model 329009 connected wirelessly at 120VAC/60Hz

FCC 15B Class B Product (Residential) @ 3 Meters										
Emission Frequency (MHz)	Measured Amplitude (dBµV/m)	Measured Amplitude (dBµV/m)	FCC 15B				Table Azimuth (0° closest to ant)	Receiving Antenna		*Average detector used for frequencies above 1 GHz.
			Limit (dBµV/m)	Limit (dBµV/m)	Margin (dB)	Margin (dB)		Pol (H/V)	Height (Meters)	
	QP/AVG*	Peak	QP/AVG*	Peak	QP/AVG*	Peak				Notes / Mode
680.619	38.10	39.60	46.0	N/A	7.9	N/A	332	V	1.6	Bass Box connected wirelessly at 120VAC/60Hz

EUT passes FCC Class B Radiated Emissions with a margin of 7.9dB at 680.619MHz

Without written permission of laboratory, this report shall not be reproduced except in full.



Wireless Transceiver Test Report



FCC ID:A94328040

IC ID:3232A-328040

Certificate # 1514.1

6.2.4. Test Equipment

Equipment Type	Manufacturer	Model	Serial or other ID	Service	
				last	due
Antenna	Sunol Sciences	JB6	TN1541	5/24/2010	5/24/2011
Receiver	Rohde & Schwarz	ESU40	TN1663	4/9/2010	4/9/2011
Pre-amp	Rohde & Schwarz	TS-PR8	TN1669	2/10/2011	2/10/2012

6.2.5. Test information

Date of test:	8 March 2011	Test location :	DCE - Maxwell House
EUT serial:	DP3-153	Tested by:	N. Sanford
Test Conclusion:	pass		

Without written permission of laboratory, this report shall not be reproduced except in full.



Wireless Transceiver Test Report



FCC ID:A94328040

IC ID:3232A-328040

Certificate # 1514.1

6.3. Output power

6.3.1. Requirements.

FCC 15.247(a)(1) , RSS 210 A8.1(b)

DTS/Frequency hopping systems operating in the band 2400-2483.5 MHz may have hopping channel carrier frequencies that are separated by 25 kHz or two-thirds of the 20 dB bandwidth of the hopping channel, whichever is greater, provided the systems operate with an output power no greater than 0.125 W.

6.3.2. Test setup details.

The transceiver is controlled via a TTL serial communications link capable of directly setting the test modes of the Texas Instruments CC8520 controller. The EUT antenna is removed and the output jumpered to an on-board U.FL connector. This is connected with a short U.FL adapter to a peak reading (diode detector) RF power meter. The loss of the adapter is manually added to the power meter reading. The transceiver is operated in an artificial test mode controlled by the serial link. The EUT is programmed to stop hopping and operated with modulation at fixed frequencies at the low end, middle and high end of the authorized frequency band.

Test Setup Block diagram:

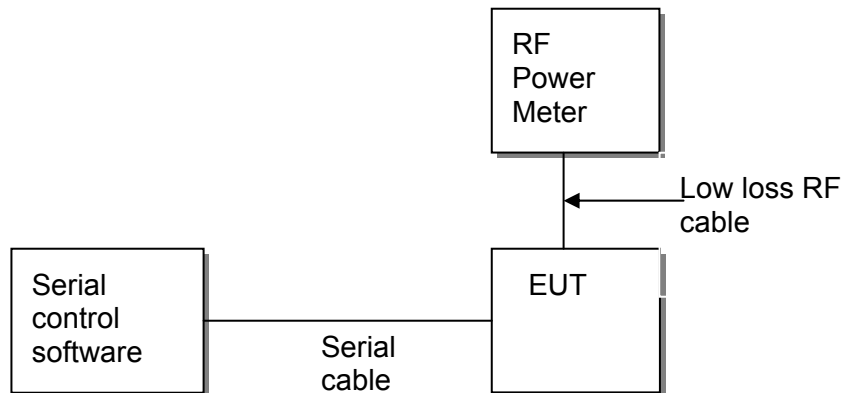

Without written permission of laboratory, this report shall not be reproduced except in full.



Wireless Transceiver Test Report



FCC ID:A94328040

IC ID:3232A-328040

Certificate # 1514.1

6.3.3. Test data.

Summary: peak, max power = 8.25dBm = 0.0067W

Test detail: Max power, modulation on.

Channel	Frequency MHz	Power dBm
1	2406	7.78
9	2438	7.93
18	2474	8.25

6.3.4. Test Equipment

Equipment Type	Manufacturer	Model	Serial or other ID	Service date	
				Last	Due
RF Power Meter	Boonton	5232	TN 1391	5/11/2011	5/11/2012
Power Sensor	Boonton	51011-EMC	TN 1392	5/11/2011	5/11/2012

6.3.5. Test information

Date of test:	28 June 2011	Test location:	BT test station
EUT serial:	DP3-153	Tested by:	Brent DeWitt
Test Conclusion:	pass		

Without written permission of laboratory, this report shall not be reproduced except in full.



Wireless Transceiver Test Report



FCC ID:A94328040

IC ID:3232A-328040

Certificate # 1514.1

6.4. Occupied Bandwidth/Channel Spacing

6.4.1. Requirements

RSS210 section 8.1

The bandwidth of a frequency hopping channel is the 20 dB emission bandwidth, measured with the hopping stopped. The system RF bandwidth is equal to the channel bandwidth multiplied by the number of channels in the hopping frequency set.

FCC part 15.247(a)(1), RSS210 section 8.1(b)

The hopping channel carrier frequencies are separated by at least 2/3rd of the 20dB bandwidth provided the output power is less than 125 mW (20.96 dBm)

6.4.2. Test setup details

The test setup is identical to section 6.3. For the 99% OBW measurement, resolution bandwidth of the spectrum analyzer was set to 1 MHz, which was the next highest available setting above the required minimum 400 kHz.

6.4.3. Test data

Summary: Internal pseudo-random test modulation ("PN" test command)

Channel	Center Frequency (MHz)	20dB OBW (MHz)	99% OBW (MHz)
1	2406	4.489	5.60
9	2438	4.489	5.52
10	2442	4.569	5.60
18	2474	4.409	5.60

Conclusion: 2/3rd of the largest OBW = 2/3 x 4.569 MHz = 3.046 MHz, which is less than the carrier channel separation of 4 MHz. In addition, the output power is less than 125 mW. See section 6.3 for the measurement of output power.

The system RF bandwidth as defined in RSS210 A8.1(a) is 18 channels times 4.569 MHz = 82.242 MHz.

Without written permission of laboratory, this report shall not be reproduced except in full.



Wireless Transceiver Test Report



FCC ID:A94328040

IC ID:3232A-328040

Certificate # 1514.1

Detail results:

High Channel (18), 2474 MHz

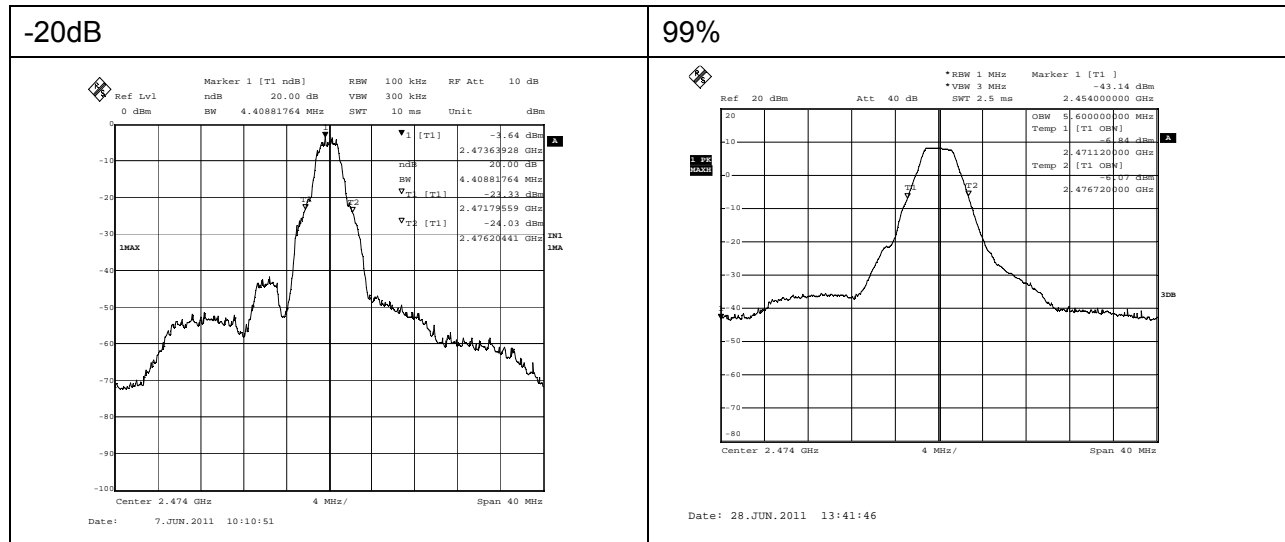

Mid channel (10), 2442 MHz

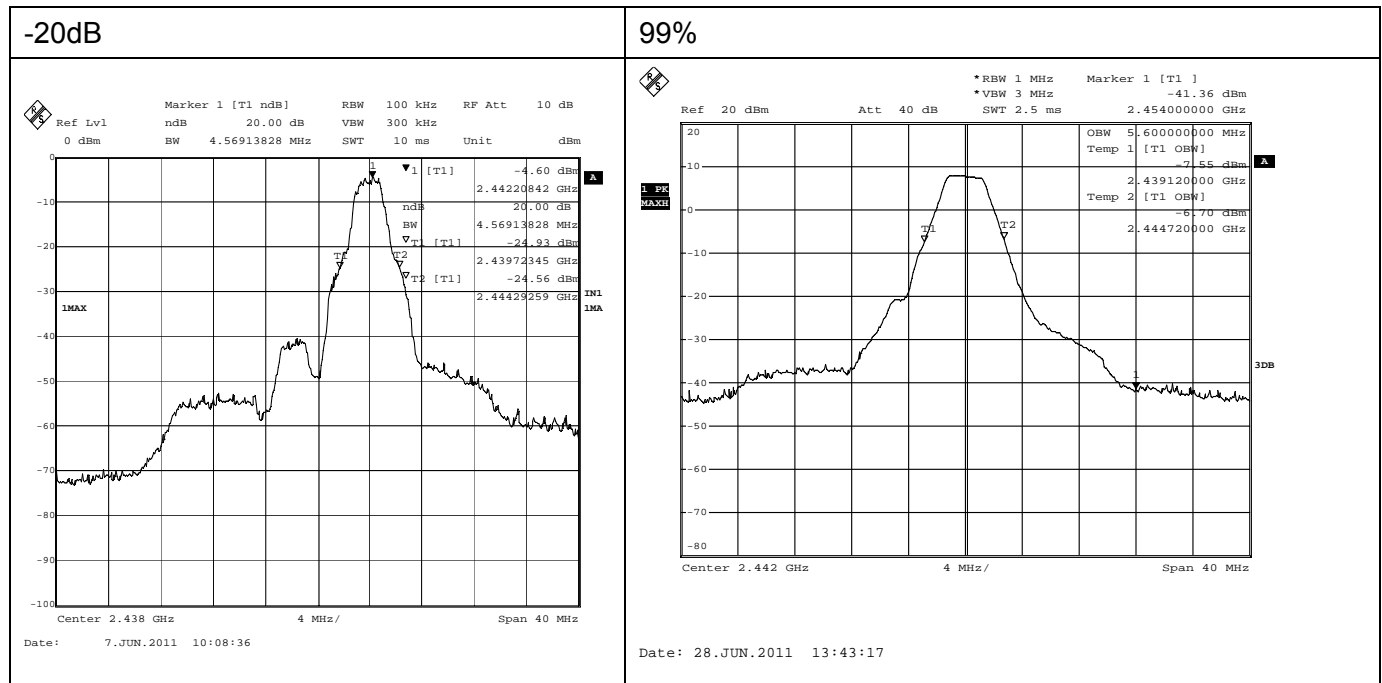

Without written permission of laboratory, this report shall not be reproduced except in full.



Wireless Transceiver Test Report



FCC ID:A94328040

IC ID:3232A-328040

Certificate # 1514.1

Mid channel (9), 2438 MHz

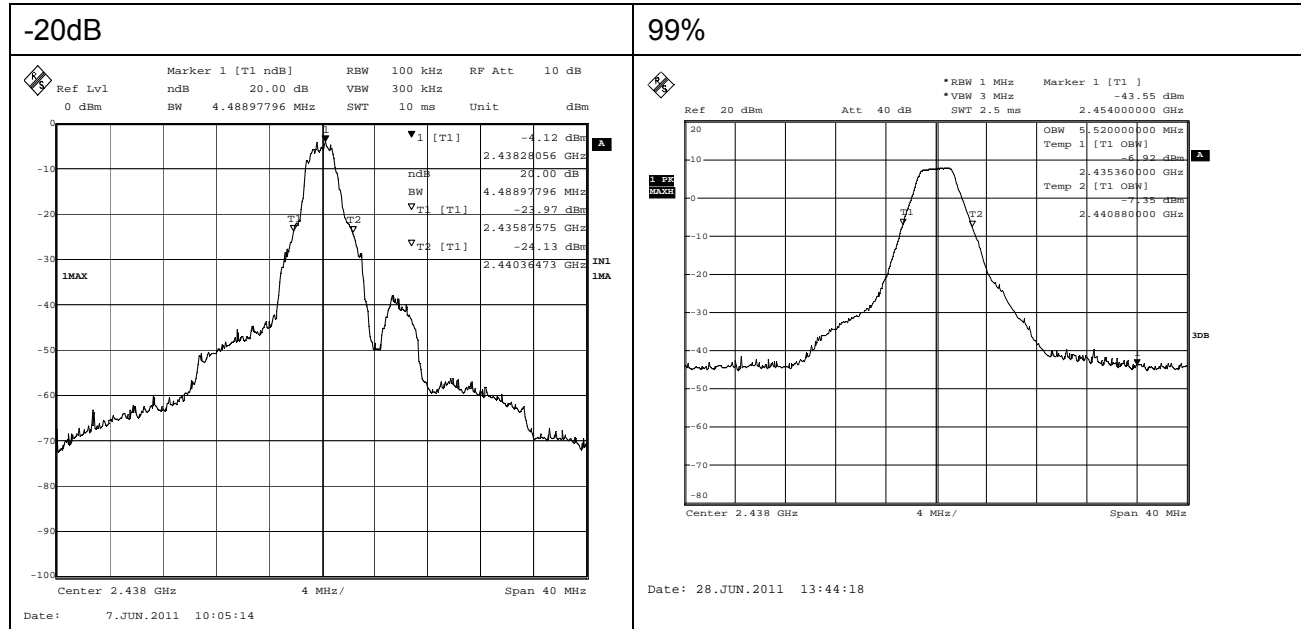

Low channel (1), 2406 MHz

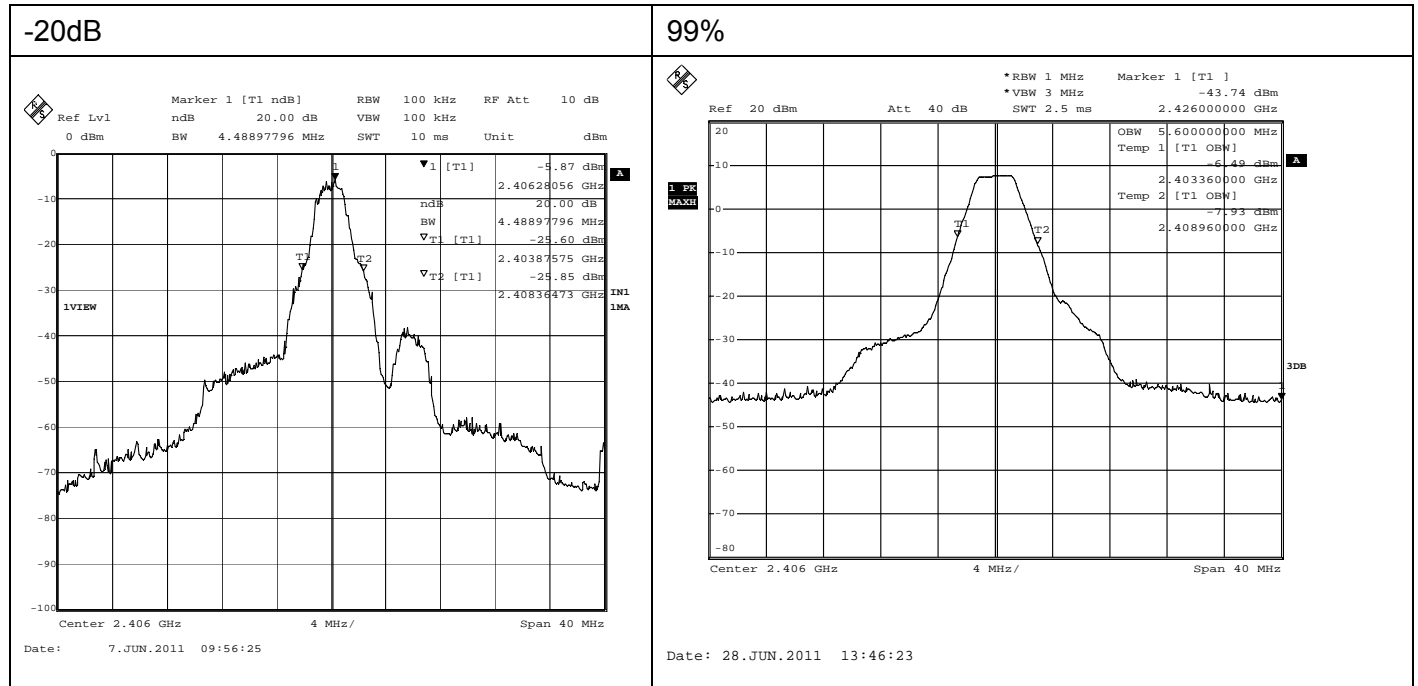

Without written permission of laboratory, this report shall not be reproduced except in full.



Wireless Transceiver Test Report



FCC ID:A94328040

IC ID:3232A-328040

Certificate # 1514.1

Channel Spacing

18 channels between 2406 MHz and 2474 MHz = 4 MHz/channel

	UNCAL	Delta 1 [T1]	RBW	100 kHz	RF Att	20 dB
	Ref Lvl	0.43 dB	VBW	1 MHz		
	10 dBm	4.00801603 MHz	SWT	5 ms	Unit	dBm

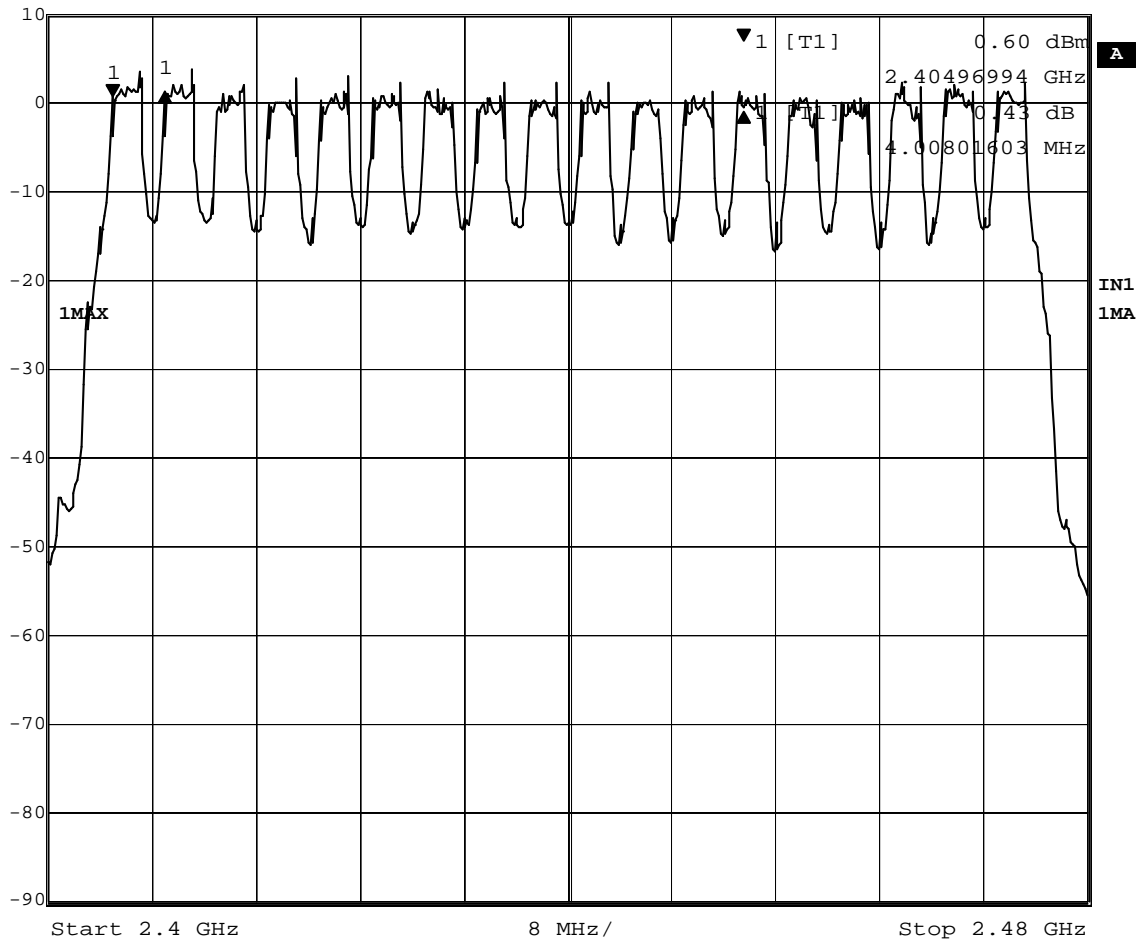

Date: 8.APR.2011 15:15:27

Without written permission of laboratory, this report shall not be reproduced except in full.



Wireless Transceiver Test Report



FCC ID:A94328040

IC ID:3232A-328040

Certificate # 1514.1

6.4.4. Test Equipment

Equipment Type	Manufacturer	Model	Serial or other ID	Service date	
				Last	Due
Spectrum analyzer	Rohde & Schwarz	ESIB 40	TN1560	4/6/2011	4/6/2012
Spectrum analyzer	Rohde & Schwarz	ESPI	TN1491	4/25/2011	4/25/2012
40 GHz cable	-	-	TN1277-18	Verify before use	

6.4.5. Test information

Date of test:	8 April 2011, 28 June 2011	Test location:	Bluetooth test station
EUT serial:	DP3-154	Test by:	Brent DeWitt
Test Conclusion:	pass		

Without written permission of laboratory, this report shall not be reproduced except in full.



Wireless Transceiver Test Report



FCC ID:A94328040

IC ID:3232A-328040

Certificate # 1514.1

6.5. Time of occupancy

6.5.1. Requirements

FCC 15.247 (f) , RSS210 A8.3 (1)

The frequency hopping operation shall have an average time occupancy on any frequency not to exceed 0.4 seconds within the duration in seconds equal to the number of hopping frequencies employed multiplied by 0.4

6.5.2. Test setup details

The SA is connected to a “sniffer” antenna in close proximity to the EUT antenna. The EUT is paired with the Model 329009 Bass Module and pink noise played. The 18 channels were examined to determine which four were carrying the data payload and the duty cycle measured.

6.5.3. Test data

Number of hopping channels is 18 (2406 – 2474 in 4 MHz increments). The longest packet transmission time is 300 microseconds for the PCMLF mode of transmission and the interval between packets is 12.5 milliseconds. $0.4 \text{ seconds} \times 18 = 7.2 \text{ seconds}$. $7.2 \text{ seconds} / 12.5 \text{ milliseconds} = 576 \text{ data packets} \times 300 \text{ microseconds} = 173 \text{ milliseconds}$ which is less than the allowed 400 milliseconds.

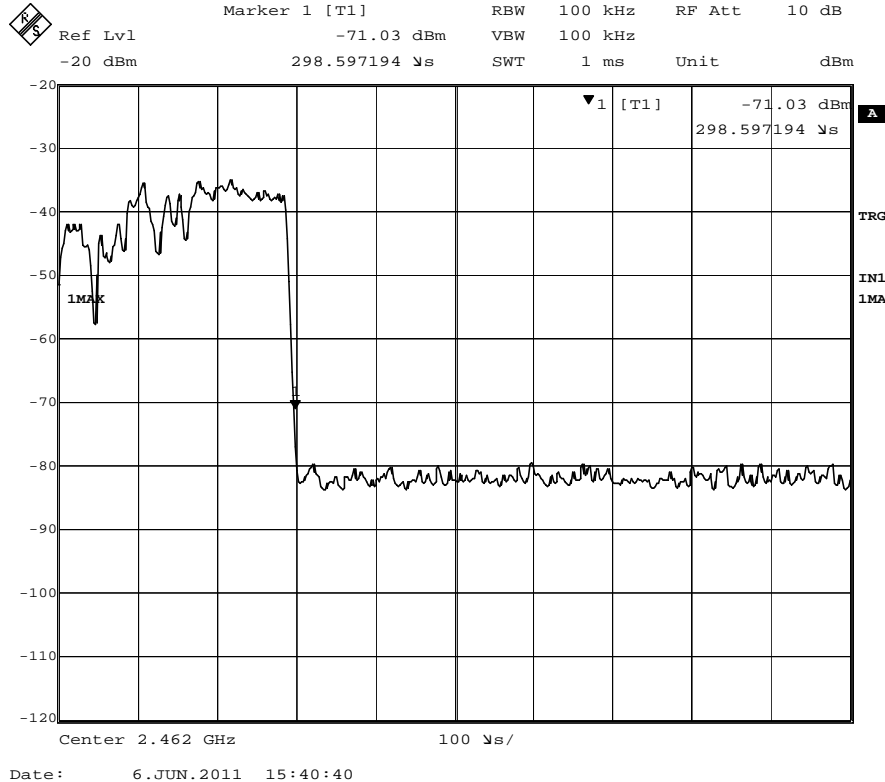

Without written permission of laboratory, this report shall not be reproduced except in full.



Wireless Transceiver Test Report



FCC ID:A94328040

IC ID:3232A-328040

Certificate # 1514.1

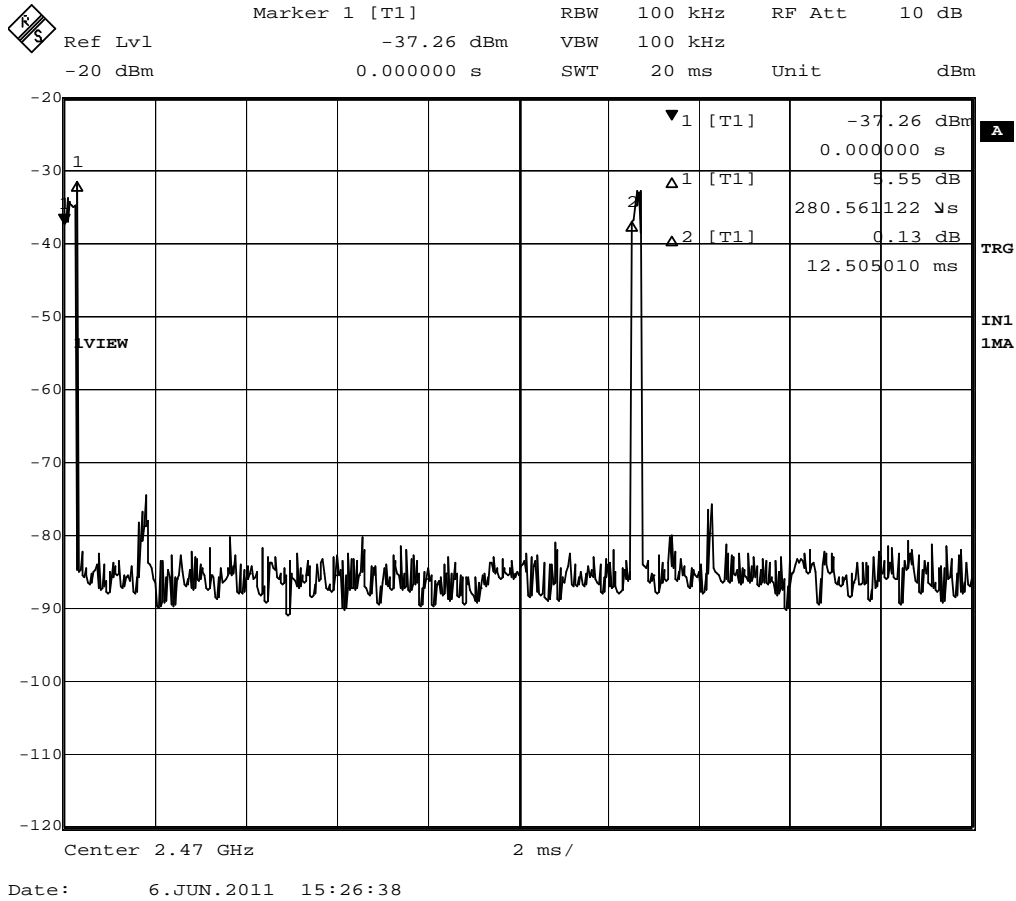

6.5.3.1. Test Equipment

Equipment Type	Manufacturer	Model	Serial or other ID	Service date	
				Last	Due
Receiver	Rohde & Schwarz	ESIB40	TN1560	4/6/2011	4/6/2012

6.5.4. Test information

Date of test:	6 June 2011	Test location:	BT test bench
Serial number:	DP3-182	Tested by:	Brent DeWitt
Test Conclusion:	pass		

Without written permission of laboratory, this report shall not be reproduced except in full.



Wireless Transceiver Test Report



FCC ID:A94328040

IC ID:3232A-328040

Certificate # 1514.1

6.6. Power Spectral Density

6.6.1. Requirements

FCC part 15.247(e), RSS210 A8.3(2)

For digitally modulated systems, the power spectral density conducted from the intentional radiator to the antenna shall not be greater than 8 dBm in any 3 kHz band during any time interval of continuous transmission.

6.6.2. Test Setup

The EUT is connectorized and connected to the Spectrum analyzer with a low loss high frequency cable. The cable loss factors are incorporated into the measured values. The EUT was placed in continuous modulated transmit, non-hopping mode. The analyzer was set to 3 kHz RBW, peak detection and 100 second sweep time, single sweep. The marker Peak function was used to determine the highest amplitude during the time period.

6.6.3. Test data

Power Spectral Density:

The maximum measure power was -10.14 dBm, which is less than the limit of 8 dBm.

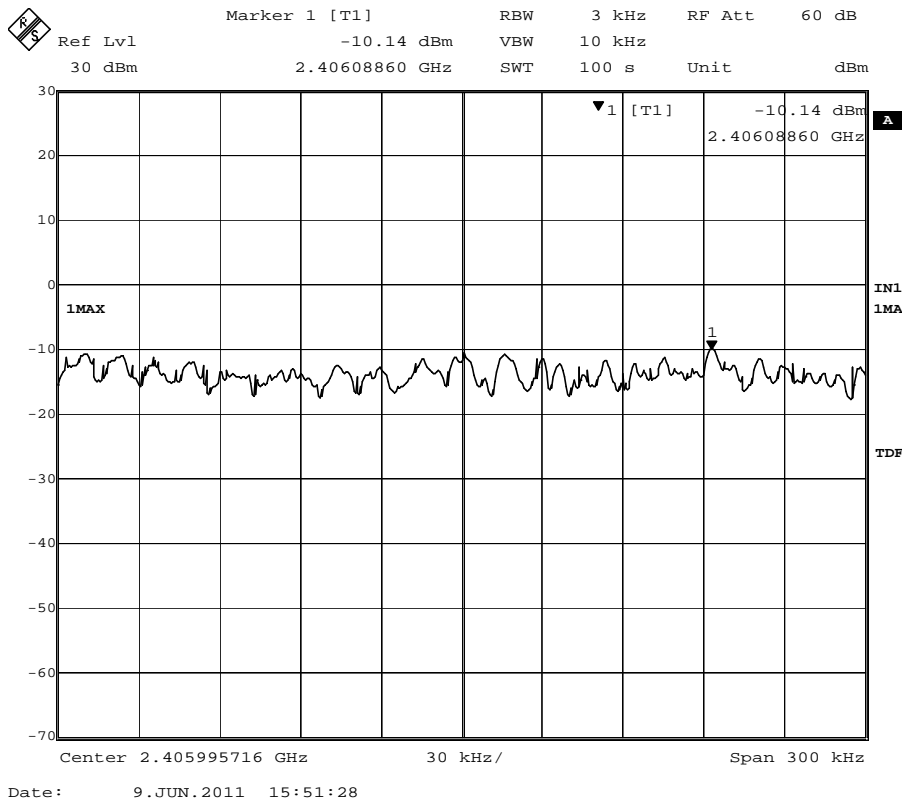

Without written permission of laboratory, this report shall not be reproduced except in full.



Wireless Transceiver Test Report



FCC ID:A94328040

IC ID:3232A-328040

Certificate # 1514.1

6.6.3.1. Test Equipment

Equipment Type	Manufacturer	Model	Serial or other ID	Service date	
				Last	Due
Receiver	Rohde & Schwarz	ESIB40	TN1560	4/6/2011	4/6/2012

6.6.4. Test information

Date of test:	9 June 2011	Test location:	BT test bench
Serial number:	DP3-182	Tested by:	Brent DeWitt
Test Conclusion:	pass		

6.7. Spurious emissions

6.7.1. Requirements

FCC part 15.247(d), RSS210 A8.5

In any 100 kHz BW, the conducted spurious emissions shall be attenuated at least 20dB below the level of the wanted signal.

6.7.2. Test Setup

The EUT is connectorized and connected to the Spectrum analyzer with a low loss high frequency cable. The cable loss factors are incorporated into the measured values. Measurements are made with the EUT in normal operation (hopping through all available channels).

6.7.3. Test data

Conducted spurious:

30 MHz – 25 GHz conducted spurious scan, 100 kHz RBW, peak detector, normal operation modulation.

Without written permission of laboratory, this report shall not be reproduced except in full.



Wireless Transceiver Test Report



FCC ID:A94328040

IC ID:3232A-328040

Certificate # 1514.1

The level of the wanted signal is 6.0 dBm in 100kHz RBW. All other conducted spurious emissions are more than 50 dB below this level.

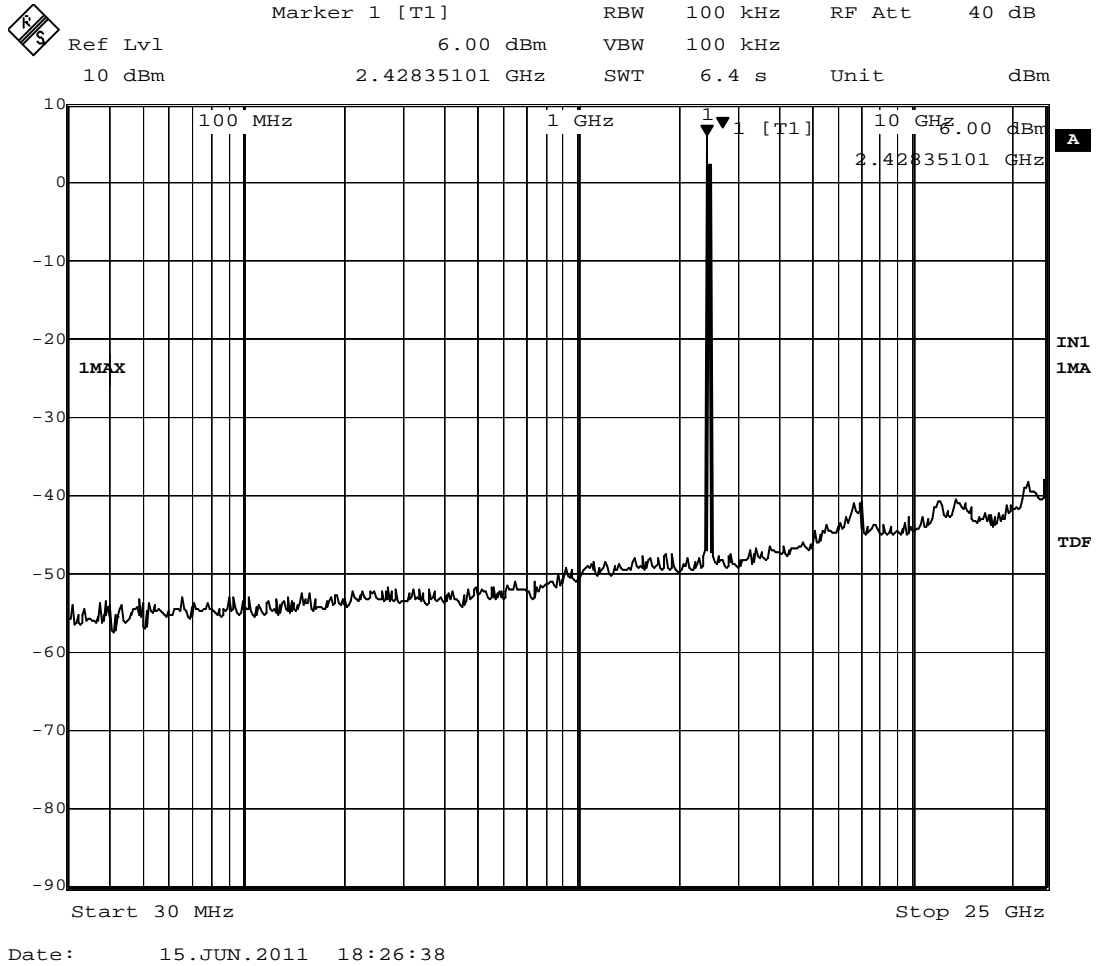

Without written permission of laboratory, this report shall not be reproduced except in full.



Wireless Transceiver Test Report



FCC ID:A94328040

IC ID:3232A-328040

Certificate # 1514.1

Conclusion:

Spurious emissions in any 100kHz bandwidth are more than 20 dB below the peak values in the desired transmission band.

6.7.4. Test Equipment

Equipment Type	Manufacturer	Model	Serial or other ID	Service date	
				Last	Due
Spectrum analyzer	Rohde & Schwarz	ESIB 40	TN1560	4/6/2011	4/6/2012
40 GHz cable	-	-	TN1277-18	Verify before use	

6.7.5. Test information

Date of test:	15 June 2011	Test Location:	BT test station
EUT serial:	DP3-154	Tested by:	Brent DeWitt
Test Conclusion:	pass		

Without written permission of laboratory, this report shall not be reproduced except in full.



Wireless Transceiver Test Report



FCC ID:A94328040

IC ID:3232A-328040

Certificate # 1514.1

6.8. Harmonics

6.8.1. Requirements

FCC part 15.247(d)

In any of the restricted bands defined in FCC part 15.209(a) , the field strength at a distance of 3 meters shall not exceed 54dBµV/m (average) or 74dBµV/m (peak)

6.8.2. Test Setup

The EUT is placed in a standard ANSI C63.10 test setup. The carrier output is measured for reference purposes. Standard gain horns with suitable pre-amps mounted directly on the horn antennas are used for the measurement of the harmonics. The EUT hopping is stopped and measurements are made in the low, mid and high end of the frequency range at the defined limit distance of 3 meters. Above 18GHz the measurement distance may be reduced to make sure the instrumentation noise floor is well below the limit.

The EUT is rotated around the vertical axis, the antenna polarization changed from H to V and the antenna height is varied from 1 to 4 meters in order to find the maximum value of the harmonic emission. Account is taken of the beam width of the horn antennas to make sure the EUT remains in the main lobe of the antenna.

6.8.3. Test data

Low band Xmit(2.406GHz)

FCC 15B Class B Product (Residential) @ 3 Meters										
Emission Frequency (MHz)	Measured Amplitude (dBµV/m) QP/AVG*	Measured Amplitude (dBµV/m) Peak	FCC 15B				Table Azimuth (0° closest to ant)	Receiving Antenna		Notes / Mode
			Limit (dBµV/m) QP/AVG*	Limit (dBµV/m) Peak	Margin (dB) QP/AVG*	Margin (dB) Peak		Pol (H/V)	Height (Meters)	
4811.900	42.60	45.60	54.0	74.0	11.4	28.4	213	H	1.0	SB Vertical
4811.900	43.60	46.20	54.0	74.0	10.4	27.8	224	V	1.0	SB Horizontal,
7217.900	49.70	51.40	54.0	74.0	4.3	22.6	23	V	1.0	SB Vertical
7217.800	47.50	49.80	54.0	74.0	6.5	24.2	172	H	1.0	SB Horizontal

Without written permission of laboratory, this report shall not be reproduced except in full.



Wireless Transceiver Test Report



FCC ID:A94328040

IC ID:3232A-328040

Certificate # 1514.1

Mid band Xmit(2.434GHz)

Emission Frequency (MHz)	Measured Amplitude (dBµV/m) QP/AVG*	Measured Amplitude (dBµV/m) Peak	FCC 15B				Table Azimuth (0° closest to ant)	Receiving Antenna		Notes / Mode
			Limit (dBµV/m) QP/AVG*	Limit (dBµV/m) Peak	Margin (dB) QP/AVG*	Margin (dB) Peak		Pol (H/V)	Height (Meters)	
4875.800	38.90	43.90	54.0	74.0	15.1	30.1	155	V	1.0	SB Vertical
4875.800	39.40	43.10	54.0	74.0	14.6	30.9	185	V	1.0	SB Horizontal
7313.900	46.10	48.70	54.0	74.0	7.9	25.3	19	V	1.0	SB Vertical
7313.900	45.00	48.00	54.0	74.0	9.0	26.0	170	H	1.0	SB Horizontal

High band Xmit(2.474GHz)

FCC 15B Class B Product (Residential) @ 3 Meters										
Emission Frequency (MHz)	Measured Amplitude (dBµV/m) QP/AVG*	Measured Amplitude (dBµV/m) Peak	FCC 15B				Table Azimuth (0° closest to ant)	Receiving Antenna		Notes / Mode
			Limit (dBµV/m) QP/AVG*	Limit (dBµV/m) Peak	Margin (dB) QP/AVG*	Margin (dB) Peak		Pol (H/V)	Height (Meters)	
4947.900	34.90	40.90	54.0	74.0	19.1	33.1	298	H	1.0	SB Vertical
4948.000	38.90	42.60	54.0	74.0	15.1	31.4	174	V	1.0	SB Horizontal
7422.100	41.10	48.60	54.0	74.0	12.9	25.4	17	V	1.0	SB Vertical
7422.100	39.70	44.30	54.0	74.0	14.3	29.7	169	H	1.0	SB Horizontal

Without written permission of laboratory, this report shall not be reproduced except in full.



Wireless Transceiver Test Report



FCC ID:A94328040

IC ID:3232A-328040

Certificate # 1514.1

At the 4th through the 10th Harmonic no signal was observed above the instrumentation noise floor. In all cases the noise floor was in excess of 10dB below the limit value.

4th – 10th harmonic instrumentation noise floor

Emission Frequency (MHz)	Measured Amplitude (dBµV/m) QP/AVG*	Measured Amplitude (dBµV/m) Peak	FCC 15B			
			Limit (dBµV/m) QP/AVG*	Limit (dBµV/m) Peak	Margin (dB) QP/AVG*	Margin (dB) Peak
9623.892	39.20	49.50	54.0	74.0	14.8	24.5
9623.892	36.80	48.30	54.0	74.0	17.2	25.7
12029.892	36.50	50.30	54.0	74.0	17.5	23.7
12029.892	36.50	50.60	54.0	74.0	17.5	23.4
14435.892	39.80	53.20	54.0	74.0	14.2	20.8
14435.892	39.70	53.00	54.0	74.0	14.3	21.0
16841.892	41.50	55.60	54.0	74.0	12.5	18.4
16841.892	41.50	55.20	54.0	74.0	12.5	18.8
19500.000	37.50	50.60	54.0	74.0	16.5	23.4
22100.000	40.20	53.10	54.0	74.0	13.8	20.9
24500.000	41.55	54.70	54.0	74.0	12.5	19.3
9752.000	36.00	48.40	54.0	74.0	18.0	25.6
9752.000	34.80	47.60	54.0	74.0	19.2	26.4
12190.000	37.80	51.00	54.0	74.0	16.2	23.0
12190.000	37.70	51.50	54.0	74.0	16.3	22.5
14628.000	41.30	54.20	54.0	74.0	12.7	19.8
14628.000	40.90	54.10	54.0	74.0	13.1	19.9
17066.000	41.40	55.30	54.0	74.0	12.6	18.7
17066.000	41.40	55.40	54.0	74.0	12.6	18.6
19500.000	37.50	50.60	54.0	74.0	16.5	23.4
22100.000	40.20	53.10	54.0	74.0	13.8	20.9
24500.000	41.55	54.70	54.0	74.0	12.5	19.3
9896.000	36.20	47.90	54.0	74.0	17.8	26.1
9896.000	33.90	47.10	54.0	74.0	20.1	26.9
12370.000	38.20	51.50	54.0	74.0	15.8	22.5
12370.000	38.00	51.30	54.0	74.0	16.0	22.7
14844.000	40.50	54.20	54.0	74.0	13.5	19.8
14844.000	40.60	53.60	54.0	74.0	13.4	20.4
17318.000	42.80	56.50	54.0	74.0	11.2	17.5
17318.000	42.80	57.00	54.0	74.0	11.2	17.0
19500.000	37.50	50.60	54.0	74.0	16.5	23.4
22100.000	40.20	53.10	54.0	74.0	13.8	20.9
24500.000	41.55	54.70	54.0	74.0	12.5	19.3

Without written permission of laboratory, this report shall not be reproduced except in full.



Wireless Transceiver Test Report



FCC ID:A94328040

IC ID:3232A-328040

Certificate # 1514.1

6.8.4. Test Equipment

Equipment Type	Manufacturer	Model	Serial or other ID	Service date	
				Last	Due
Receiver	Rohde & Schwarz	ESU40	TN1663	4/9/2010	4/9/2011
Antenna 30M – 6G	Sunol	JB6	TN1541	5/24/2010	5/24/2011
Antenna 4 – 8G	AR	AT4003	TN727	11/24/2008	11/24/2011
Antenna 8 – 18G	AR	AT4004	TN728	11/24/2008	11/24/2011
Antenna 18 – 26.5G	ETS	3160-09	TN1307	2/23/2011	2/23/2014
20 GHz Pre-amp	MITEQ	AFS4-00102000-30-10P-4	TN1672	6/2/2010	6/2/2011
40 GHz pre-amp	MITEQ	JS4018004000-30-8P-A1	TN1757	Verify before use	
Antenna cable 18GHz	Rohde & Schwarz	HFE160D	TN1692	9/9/2010	9/9/2011
40 GHz cable	-	-	TN1277-18	Verify before use	

6.8.5. Test information

Date of test:	10 March 2011	Test Location:	Maxwell House
EUT serial:	DP3-153	Tested by:	C. Bell/N. Sanford
Test Conclusion:	pass		

Without written permission of laboratory, this report shall not be reproduced except in full.



Wireless Transceiver Test Report



FCC ID:A94328040

IC ID:3232A-328040

Certificate # 1514.1

6.9. Spurious emissions 1-25 GHz

6.9.1. Requirements

FCC part 15.247(d), RSS210 section 2.2(b)

In any of the restricted bands defined in FCC part 15.209(a), the field strength at a distance of 3 meters shall not exceed 54dB μ V/m (average) or 74dB μ V/m (peak)

6.9.2. Test Setup

The EUT is placed in a standard ANSI C63.10 test setup. From 1 to 4 GHz a linearly polarized hybrid bi-conical / log-periodic antenna is used. Above 4 GHz, standard gain horns with suitable pre-amps mounted directly on the horn antennas are used for the measurement of the emissions.

The EUT is operating normally (hopping), and measurements are made at the defined limit distance of 3 meters. Above 18GHz the measurement distance may be reduced to make sure the instrumentation noise floor is well below the limit. Measurements are made with a 1 MHz resolution bandwidth and an average detector. There is an implied peak limit 20dB above the average limit.

The EUT is rotated around the vertical axis, the antenna polarization changed from H to V and the antenna height is varied from 1 to 4 meters in order to find the maximum value of the emissions. Account is taken of the beam width of the horn antennas to make sure the EUT remains in the main lobe of the antenna.

6.9.2.1. Test data

Frequency range 30MHz – 1 GHz. Passes, see section 6.2 of this report.

No spurious emissions were found above 8 GHz. See section 6.8.3 for noise floor details.

Without written permission of laboratory, this report shall not be reproduced except in full.



Wireless Transceiver Test Report



FCC ID:A94328040

IC ID:3232A-328040

Certificate # 1514.1

Frequency range 1 – 2.4 GHz

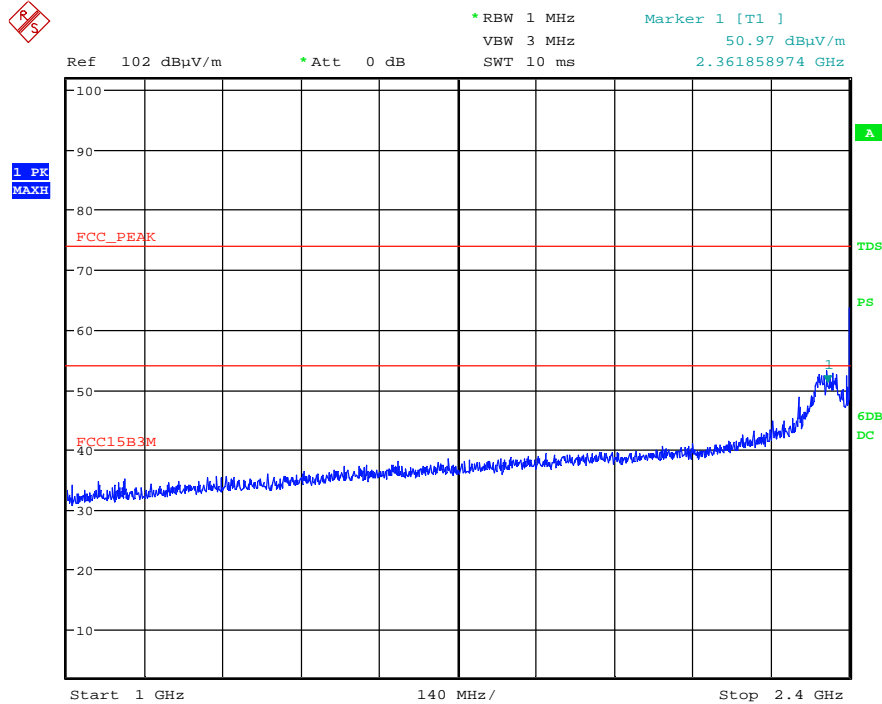

Date: 10.MAR.2011 11:01:07

Low band Xmit(2.406GHz) spurious measurement, Soundbar in vertical position.

Emission Frequency (MHz)	Measured Amplitude (dBμV/m) QP/AVG*	Measured Amplitude (dBμV/m) Peak	FCC 15B				Table Azimuth (0° closest to ant)	Receiving Antenna	
			Limit (dBμV/m) QP/AVG*	Limit (dBμV/m) Peak	Margin (dB) QP/AVG*	Margin (dB) Peak		Pol (H/V)	Height (Meters)
2357.900	42.40	52.10	54.0	74.0	11.6	21.9	0	V	1.0

Without written permission of laboratory, this report shall not be reproduced except in full.



Wireless Transceiver Test Report



FCC ID:A94328040

IC ID:3232A-328040

Certificate # 1514.1



* RBW 1 MHz Marker 1 [T1]
 VBW 3 MHz 48.57 dBμV/m
 SWT 10 ms 2.361858974 GHz

Ref 102 dBμV/m

* Att 0 dB

1 PK
MAXH

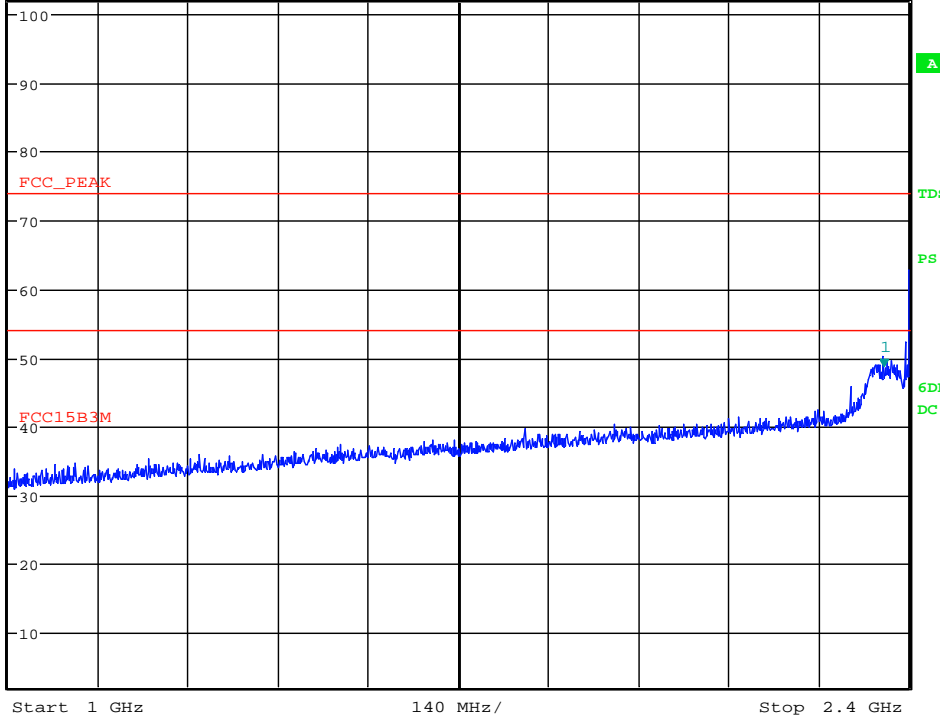

Date: 10.MAR.2011 11:02:49

Low band Xmit(2.406GHz) spurious measurement, Soundbar in horizontal position.
TN1445, TN1541, TN1669

Without written permission of laboratory, this report shall not be reproduced except in full.



Wireless Transceiver Test Report



FCC ID:A94328040

IC ID:3232A-328040

Certificate # 1514.1



* RBW 1 MHz Marker 1 [T1]
 VBW 3 MHz 51.26 dBμV/m
 SWT 10 ms 2.390000000 GHz

Ref 102 dBμV/m

* Att 0 dB

1 PK
MAXH

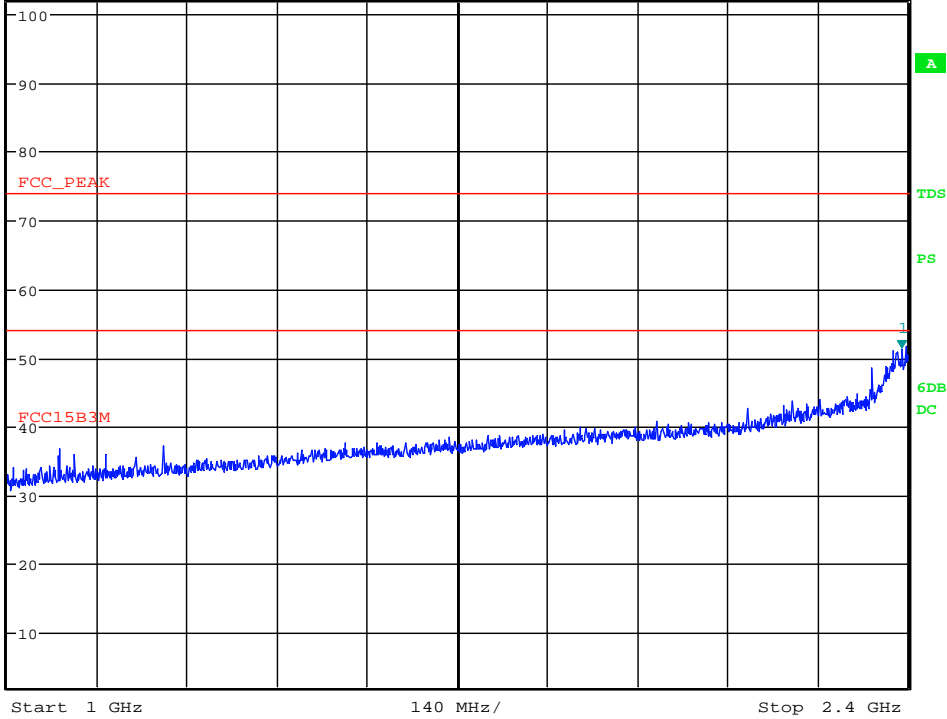

Date: 10.MAR.2011 10:55:07

Mid band Xmit (2.434GHz), spurious measurement, Soundbar in vertical position.
TN1445,TN1541, TN1669

Without written permission of laboratory, this report shall not be reproduced except in full.



Wireless Transceiver Test Report



FCC ID:A94328040

IC ID:3232A-328040

Certificate # 1514.1



* RBW 1 MHz Marker 1 [T1]
 VBW 3 MHz 50.23 dBµV/m
 SWT 10 ms 2.390000000 GHz

Ref 102 dBµV/m

* Att 0 dB

1 PK
MAXH

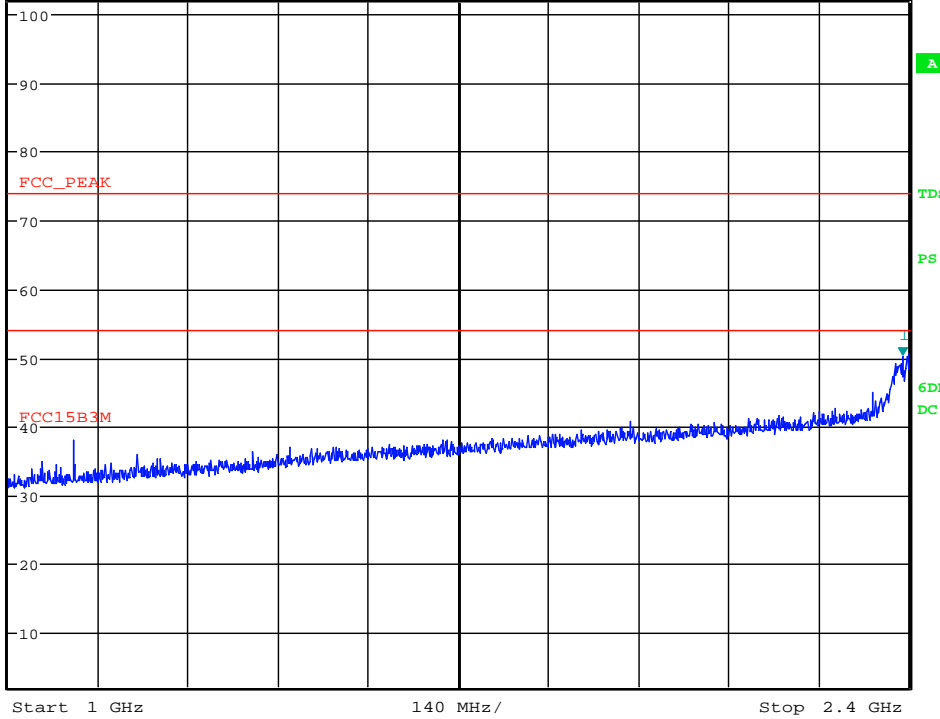

Date: 10.MAR.2011 10:57:33

Mid band Xmit (2.434GHz), spurious measurement, Soundbar in horizontal position.
TN1445, TN1541, TN1669

Without written permission of laboratory, this report shall not be reproduced except in full.



Wireless Transceiver Test Report



FCC ID:A94328040

IC ID:3232A-328040

Certificate # 1514.1



* RBW 1 MHz Marker 1 [T1]
VBW 3 MHz 42.42 dBµV/m
SWT 10 ms 2.361858974 GHz

Ref 102 dBµV/m

* Att 0 dB

1 PK
MAXH

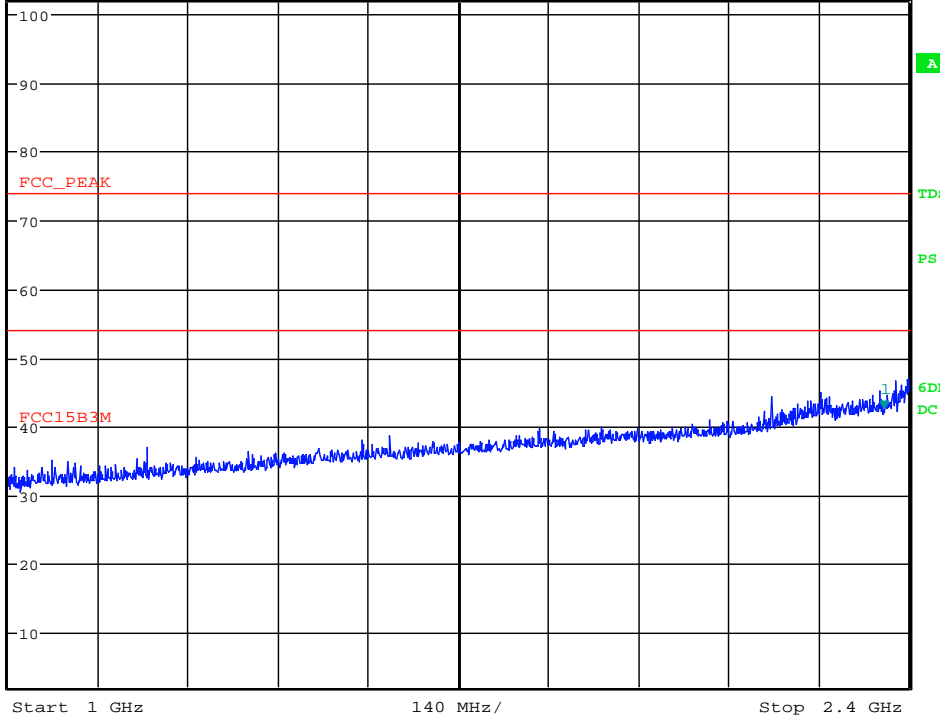

Date: 10.MAR.2011 11:06:45

High band Xmit (2.474GHz), spurious measurement, Soundbar in vertical position.
TN1445, TN1541, TN1669

Without written permission of laboratory, this report shall not be reproduced except in full.



Wireless Transceiver Test Report



FCC ID:A94328040

IC ID:3232A-328040

Certificate # 1514.1



* RBW 1 MHz Marker 1 [T1]
 VBW 3 MHz 45.94 dBµV/m
 SWT 10 ms 2.397756410 GHz

Ref 102 dBµV/m

* Att 0 dB

1 PK
MAXH

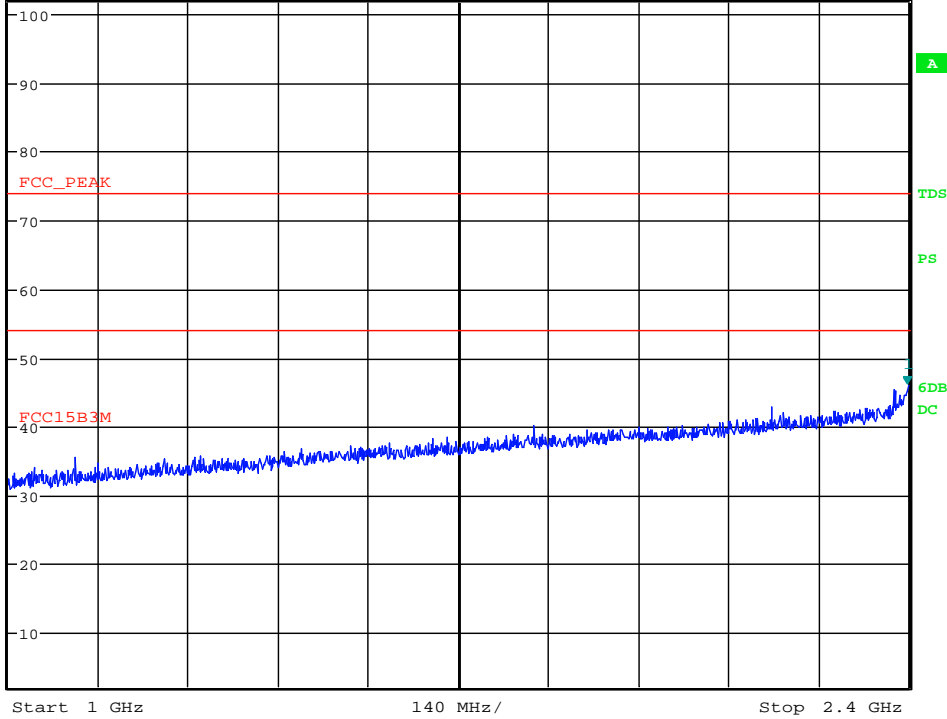

Date: 10.MAR.2011 11:08:31

High band Xmit (2.474GHz), spurious measurement, Soundbar in horizontal position.
TN1445,TN1541, TN1669

Without written permission of laboratory, this report shall not be reproduced except in full.



Wireless Transceiver Test Report



FCC ID:A94328040

IC ID:3232A-328040

Certificate # 1514.1



* RBW 1 MHz
VBW 3 MHz
SWT 20 ms

Ref 102 dBµV/m

* Att 0 dB

1 PK
MAXH

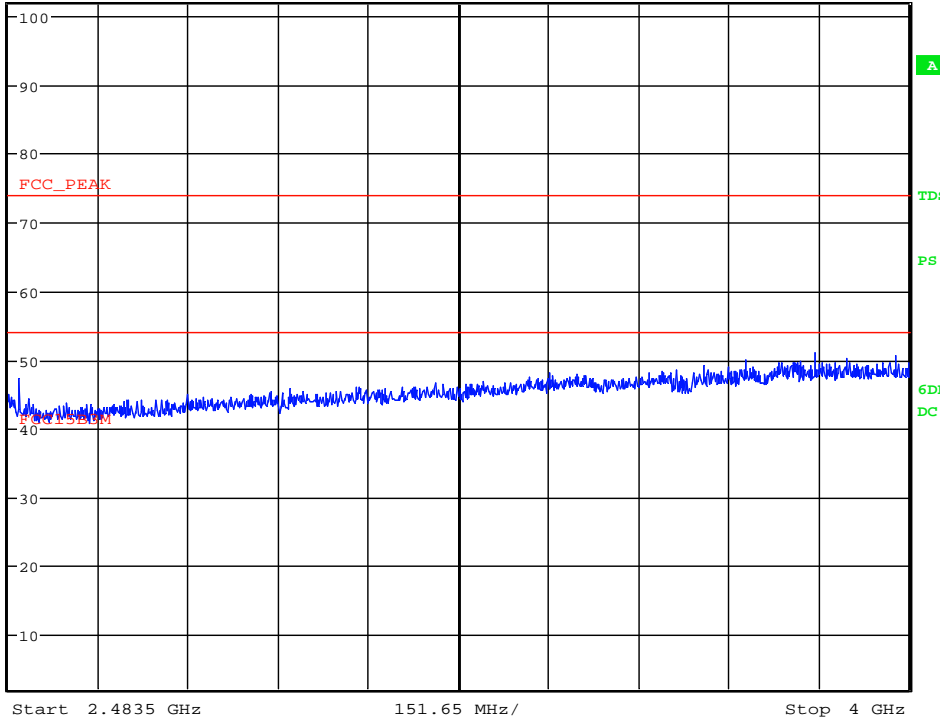

Date: 10.MAR.2011 12:37:05

Low band Xmit(2.406GHz) spurious measurement, Soundbar in vertical position.
TN1445, TN1541, TN1669.

Without written permission of laboratory, this report shall not be reproduced except in full.



Wireless Transceiver Test Report



FCC ID:A94328040

IC ID:3232A-328040

Certificate # 1514.1

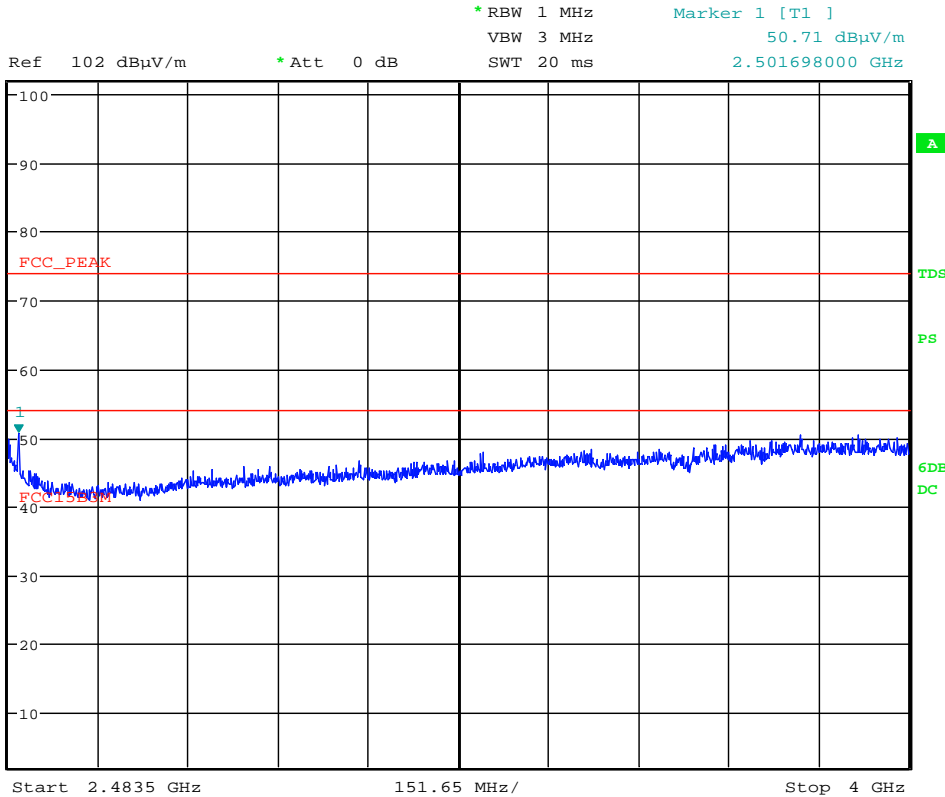

Date: 10.MAR.2011 12:43:00

Low band Xmit(2.406GHz) spurious measurement, Soundbar in horizontal position.
 TN1445, TN1541, TN1669.

Emission Frequency (MHz)	Measured Amplitude (dBµV/m) QP/AVG*	Measured Amplitude (dBµV/m) Peak	FCC 15B				Table Azimuth (0° closest to ant)	Receiving Antenna	
			Limit (dBµV/m) QP/AVG*	Limit (dBµV/m) Peak	Margin (dB) QP/AVG*	Margin (dB) Peak		Pol (H/V)	Height (Meters)
2502.000	46.50	53.80	54.0	74.0	7.5	20.2	173	V	1.0

Without written permission of laboratory, this report shall not be reproduced except in full.



Wireless Transceiver Test Report



FCC ID:A94328040

IC ID:3232A-328040

Certificate # 1514.1



* RBW 1 MHz Marker 1 [T1]
 VBW 3 MHz 46.76 dBμV/m
 SWT 20 ms 2.533544500 GHz

Ref 102 dBμV/m

* Att 0 dB

1 PK
MAXH

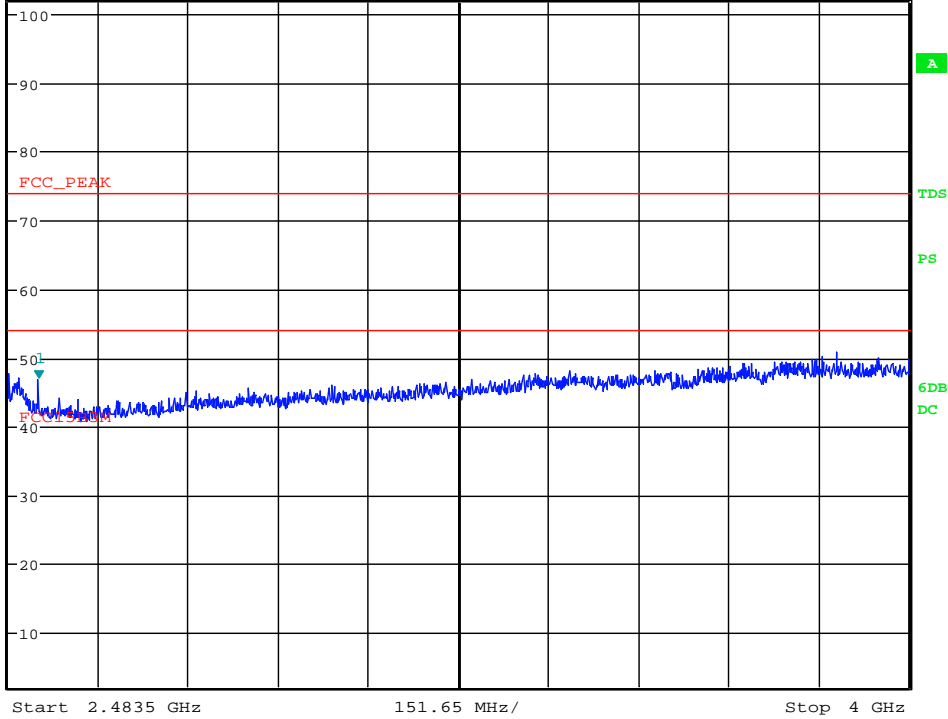

Date: 10.MAR.2011 13:31:10

Mid band Xmit (2.434GHz), spurious measurement, Soundbar in vertical position.
TN1445,TN1541, TN1669

Without written permission of laboratory, this report shall not be reproduced except in full.



Wireless Transceiver Test Report



FCC ID:A94328040

IC ID:3232A-328040

Certificate # 1514.1

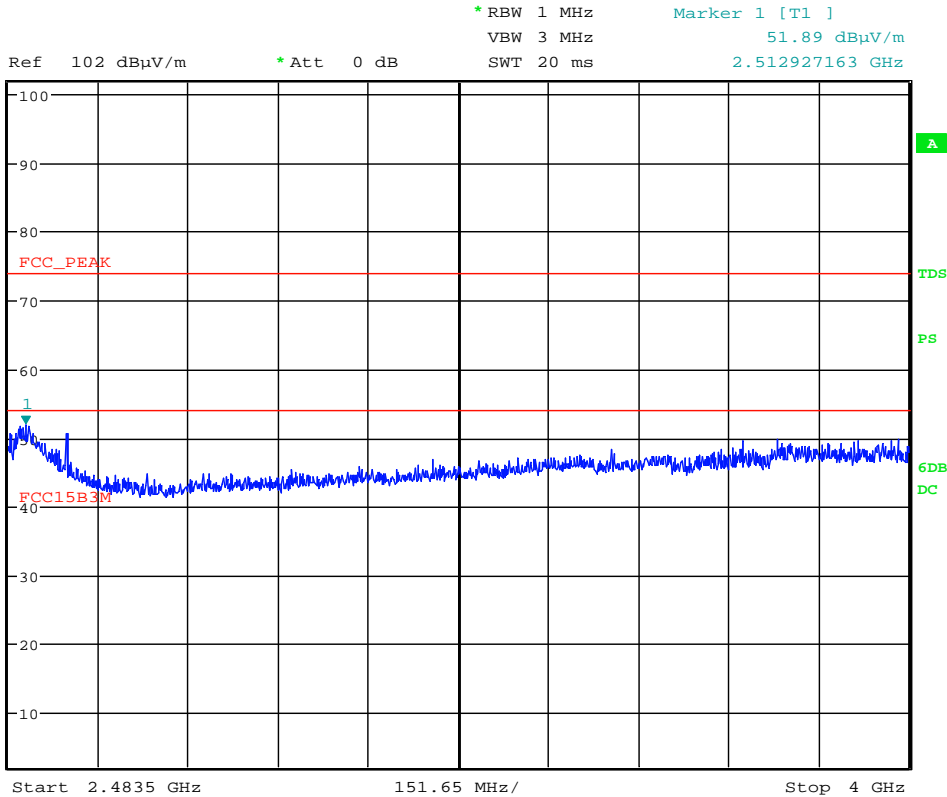

Date: 10.MAR.2011 13:34:20

Mid band Xmit (2.434GHz), spurious measurement, Soundbar in horizontal position.
 TN1445, TN1541, TN1669

Emission Frequency (MHz)	Measured Amplitude (dBµV/m) QP/AVG*	Measured Amplitude (dBµV/m) Peak	FCC 15B				Table Azimuth (0° closest to ant)	Receiving Antenna	
			Limit (dBµV/m) QP/AVG*	Limit (dBµV/m) Peak	Margin (dB) QP/AVG*	Margin (dB) Peak		Pol (H/V)	Height (Meters)
2496.000	39.70	53.90	54.0	74.0	14.3	20.1	179	V	1.0

Without written permission of laboratory, this report shall not be reproduced except in full.



Wireless Transceiver Test Report



FCC ID:A94328040

IC ID:3232A-328040

Certificate # 1514.1



* RBW 1 MHz Marker 1 [T1]
 VBW 3 MHz 47.67 dBμV/m
 SWT 20 ms 2.538385635 GHz

Ref 102 dBμV/m

* Att 0 dB

1 PK
MAXH

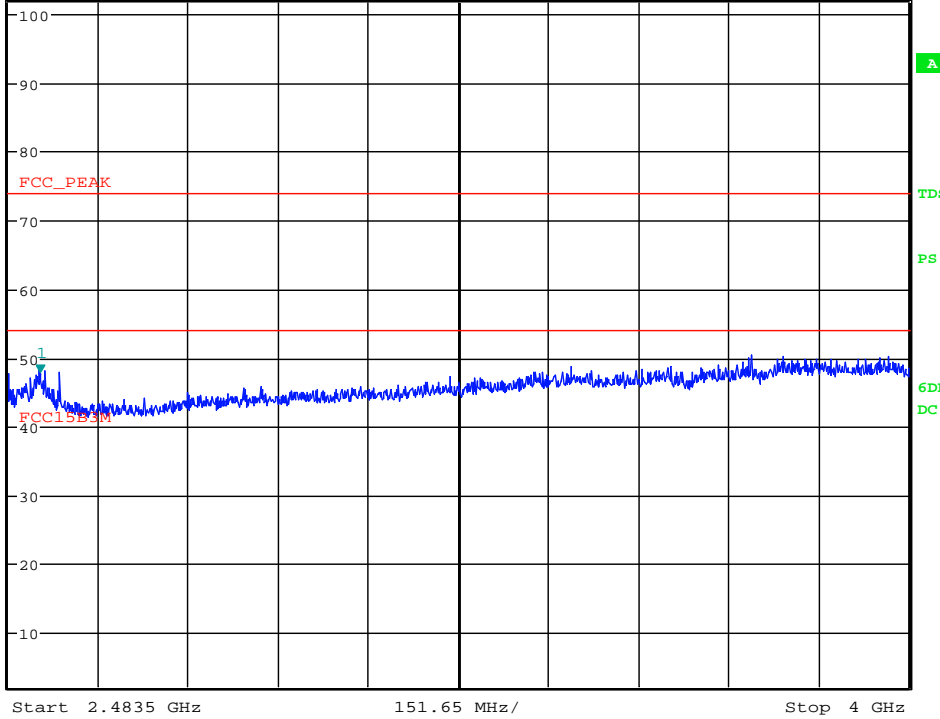

Date: 10.MAR.2011 13:18:07

High band Xmit (2.474GHz), spurious measurement, Soundbar in vertical position.
TN1445,TN1541, TN1669

Without written permission of laboratory, this report shall not be reproduced except in full.



Wireless Transceiver Test Report



FCC ID:A94328040

IC ID:3232A-328040

Certificate # 1514.1

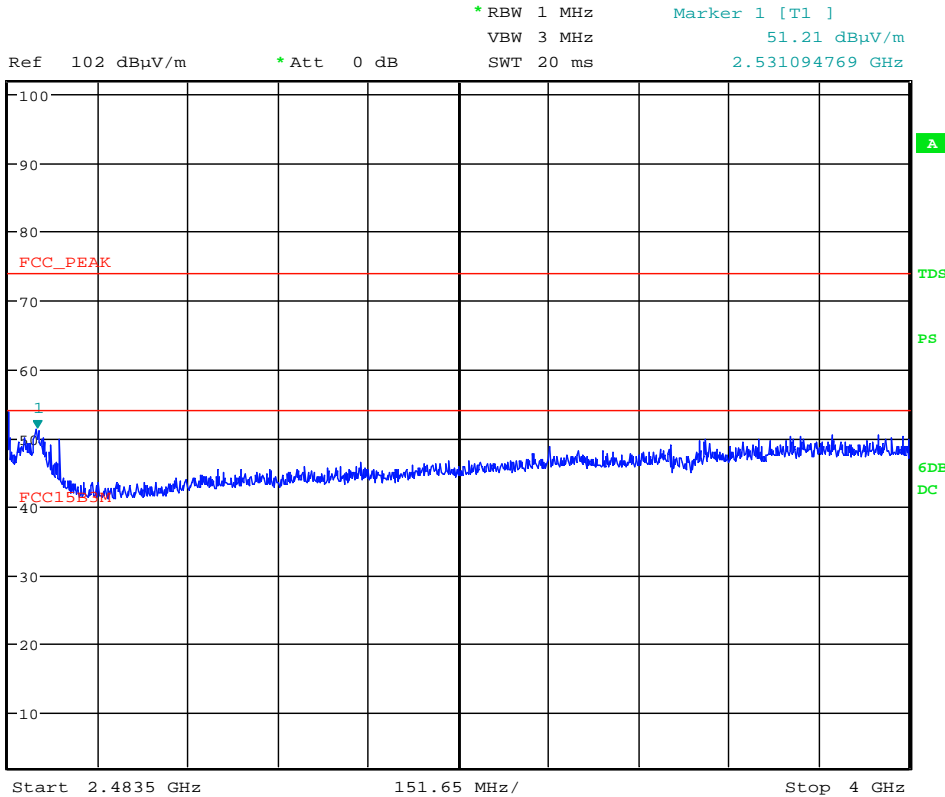

Date: 10.MAR.2011 13:20:19

High band Xmit (2.474GHz), spurious measurement, Soundbar in horizontal position.
 TN1445, TN1541, TN1669

Emission Frequency (MHz)	Measured Amplitude (dBµV/m) QP/AVG*	Measured Amplitude (dBµV/m) Peak	FCC 15B				Table Azimuth (0° closest to ant)	Receiving Antenna	
			Limit (dBµV/m) QP/AVG*	Limit (dBµV/m) Peak	Margin (dB) QP/AVG*	Margin (dB) Peak		Pol (H/V)	Height (Meters)
2533.000	40.30	53.60	54.0	74.0	13.7	20.4	173	V	1.0

Without written permission of laboratory, this report shall not be reproduced except in full.



Wireless Transceiver Test Report



FCC ID:A94328040

IC ID:3232A-328040

Certificate # 1514.1

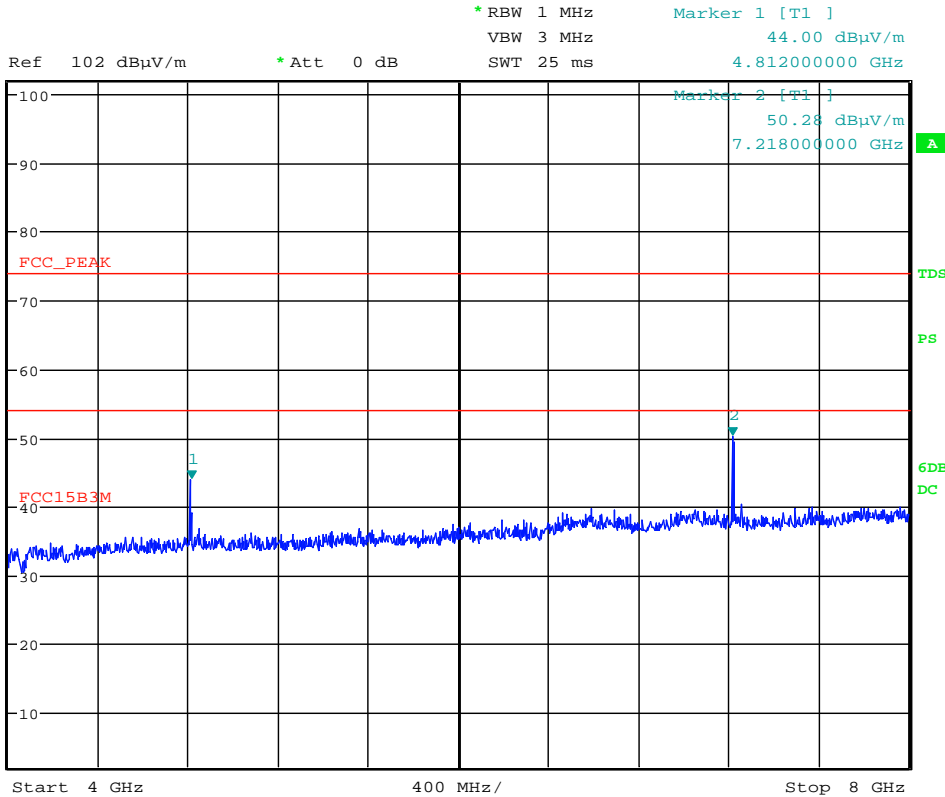

Date: 10.MAR.2011 14:18:11

Low band Xmit(2.406GHz) spurious measurement. TN1692,TN727, TN1669.

FCC 15B Class B Product (Residential) @ 3 Meters										
Emission Frequency (MHz)	Measured Amplitude (dBµV/m) QP/AVG*	Measured Amplitude (dBµV/m) Peak	FCC 15B				Table Azimuth (0° closest to ant)	Receiving Antenna		*Average detector used for frequencies above 1 GHz. Notes / Mode
			Limit (dBµV/m) QP/AVG*	Limit (dBµV/m) Peak	Margin (dB) QP/AVG*	Margin (dB) Peak		Pol (H/V)	Height (Meters)	
4811.900	42.60	45.60	54.0	74.0	11.4	28.4	213	H	1.0	SB Vertical, Low band
4811.900	43.60	46.20	54.0	74.0	10.4	27.8	224	V	1.0	SB Horizontal, Low band
7217.900	49.70	51.40	54.0	74.0	4.3	22.6	23	V	1.0	SB Vertical, Low band
7217.800	47.50	49.80	54.0	74.0	6.5	24.2	172	H	1.0	SB

Without written permission of laboratory, this report shall not be reproduced except in full.



Wireless Transceiver Test Report



FCC ID:A94328040

IC ID:3232A-328040

Certificate # 1514.1

										mid band
4875.800	39.40	43.10	54.0	74.0	14.6	30.9	185	V	1.0	SB Horizontal, mid band
7313.900	46.10	48.70	54.0	74.0	7.9	25.3	19	V	1.0	SB Vertical, mid band
7313.900	45.00	48.00	54.0	74.0	9.0	26.0	170	H	1.0	SB Horizontal, mid band



*RBW 1 MHz Marker 1 [T1]
 VBW 3 MHz 39.21 dBµV/m
 Ref 102 dBµV/m *Att 0 dB SWT 25 ms 4.948410256 GHz

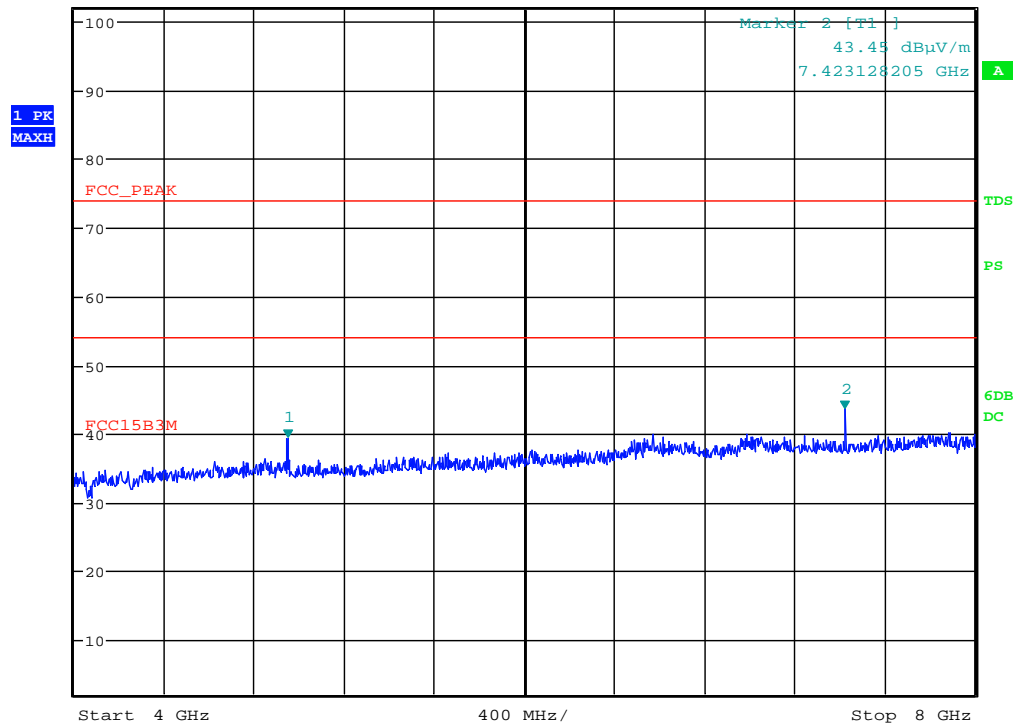

Date: 10.MAR.2011 15:14:50

Without written permission of laboratory, this report shall not be reproduced except in full.



Wireless Transceiver Test Report



FCC ID:A94328040

IC ID:3232A-328040

Certificate # 1514.1

High band Xmit(2.474GHz) spurious measurement. TN1692,TN727, TN1669.

FCC 15B Class B Product (Residential) @ 3 Meters										
Emission Frequency (MHz)	Measured Amplitude (dBµV/m) QP/AVG*	Measured Amplitude (dBµV/m) Peak	FCC 15B				Table Azimuth (0° closest to ant)	Receiving Antenna		*Average detector used for frequencies above 1 GHz. Notes / Mode
			Limit (dBµV/m) QP/AVG*	Limit (dBµV/m) Peak	Margin (dB) QP/AVG*	Margin (dB) Peak		Pol (H/V)	Height (Meters)	
4947.900	34.90	40.90	54.0	74.0	19.1	33.1	298	H	1.0	SB Vertical, High band
4948.000	38.90	42.60	54.0	74.0	15.1	31.4	174	V	1.0	SB Horizontal, High band
7422.100	41.10	48.60	54.0	74.0	12.9	25.4	17	V	1.0	SB Vertical, High band
7422.100	39.70	44.30	54.0	74.0	14.3	29.7	169	H	1.0	SB Horizontal, High band

6.9.3. Test Equipment

Equipment Type	Manufacturer	Model	Serial or other ID	Service date	
				Last	Due
Receiver	Rohde & Schwarz	ESU40	TN1663	4/9/2010	4/9/2011
Antenna 30M – 6G	Sunol	JB6	TN1541	5/24/2010	5/24/2011
Antenna 4 – 8G	AR	AT4003	TN727	11/24/2008	11/24/2011
Antenna 8 – 18G	AR	AT4004	TN728	11/24/2008	11/24/2011
Antenna 18 – 26.5G	ETS	3160-09	TN1307	2/23/2011	2/23/2014
20 GHz Pre-amp	MITEQ	AFS4-00102000-30-10P-4	TN1672	6/2/2010	6/2/2011
40 GHz pre-amp	MITEQ	JS4018004000-30-8P-A1	TN1757	Verify before use	
Antenna cable 18GHz	Rohde & Schwarz	HFE160D	TN1692	9/9/2010	9/9/2011
40 GHz cable	-	-	TN1277-18	Verify before use	

Without written permission of laboratory, this report shall not be reproduced except in full.



Wireless Transceiver Test Report



FCC ID:A94328040

IC ID:3232A-328040

Certificate # 1514.1

6.9.4. Test information

Date of test:	10 March 2011	Test Location:	Maxwell House
EUT serial:	DP3-153	Tested by:	K. Thibodeau
Test Conclusion:	pass		

Without written permission of laboratory, this report shall not be reproduced except in full.



Wireless Transceiver Test Report



FCC ID:A94328040

IC ID:3232A-328040

Certificate # 1514.1

6.10. Receiver spurious emissions

6.10.1. Requirements

RSS-Gen section 4.10

- if the antenna is detachable, a conducted measurement may be performed.

RSS-GEN section 6(b)

No spurious output signals appearing at the antenna terminals shall exceed 2 nW (-57dBm) per any 4 kHz spurious frequency in the band 30-1000 MHz, or 5 nW (-53dBm) above 1 GHz.

6.10.2. Test Setup

The EUT is tuned to the middle of the band and placed in receive mode. (TX idle).

Conducted:

The EUT is connected with a low loss cable to the spectrum analyzer and placed in receive mode, tuned to the middle of the band (channel 39, 2441 MHz). Cable losses are incorporated in the measured results by the measurement software. A spectrum scan is made from 30 MHz to 12.75 GHz (covering the required 30MHz – 7.5 GHz range) with a 30 kHz RBW (more than the required 4 kHz).

6.10.3. Test data

No emissions found greater than -75 dBm. EUT meets the requirement.

Without written permission of laboratory, this report shall not be reproduced except in full.



Wireless Transceiver Test Report



FCC ID:A94328040

IC ID:3232A-328040

Certificate # 1514.1



Marker 1 [T1] RBW 30 kHz RF Att 10 dB
 Ref Lvl -82.05 dBm VBW 30 kHz Mixer -20 dBm
 0 dBm 2.23131517 GHz SWT 35 s Unit dBm

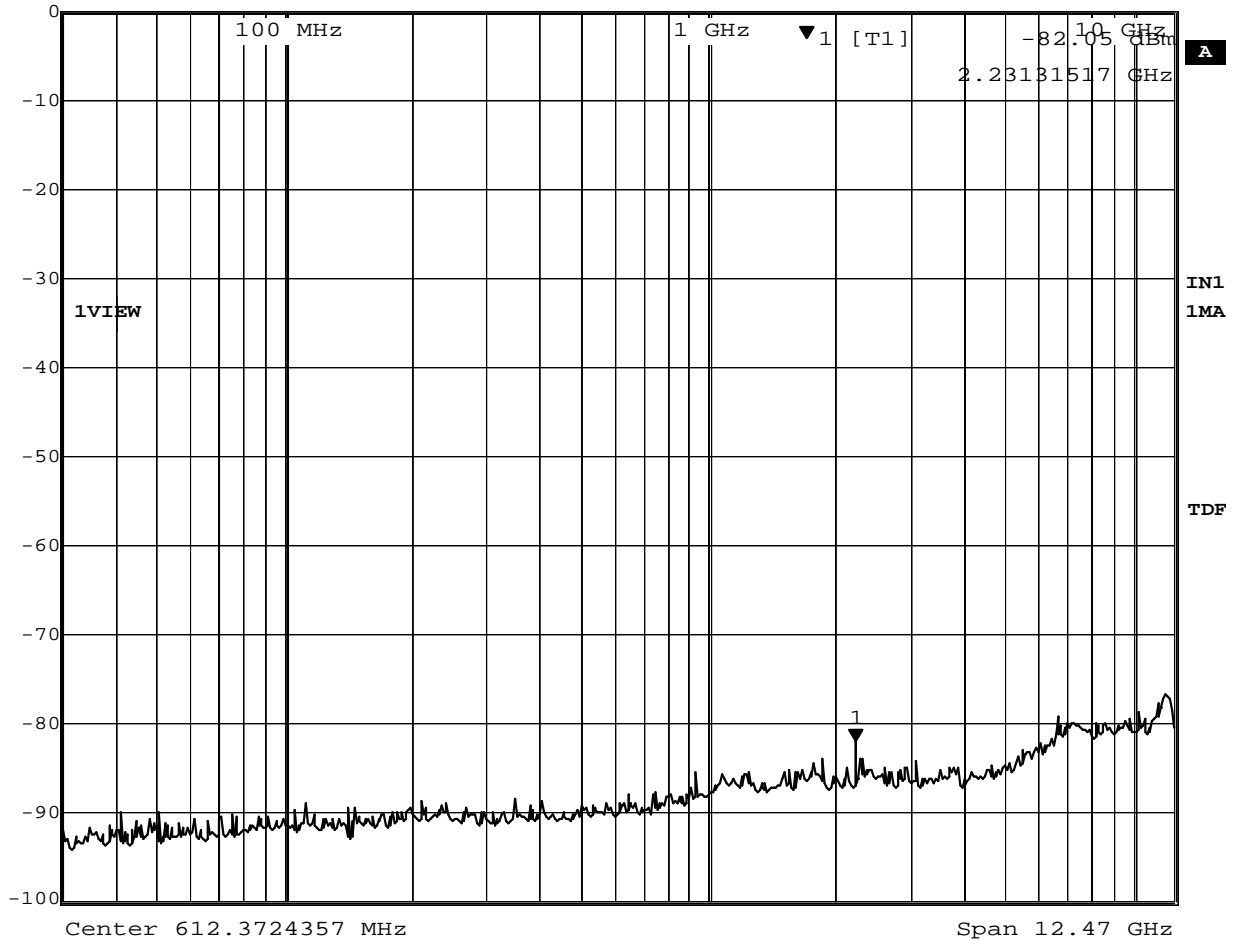

Date: 16.JUN.2011 18:06:43

6.10.4. Test Equipment

Equipment Type	Manufacturer	Model	Serial or other ID	Service date	
				Last	Due
Spectrum analyzer	Rohde & Schwarz	ESIB 40	TN1560	4/6/2011	4/6/2012
40 GHz cable	-	-	TN1277-18	Verify before use	

6.10.5. Test information

Date of test:	16 June 2011	Test location:	Bluetooth test station
EUT serial:	DP3-154	Test by:	Brent DeWitt

Without written permission of laboratory, this report shall not be reproduced except in full.



Wireless Transceiver Test Report



FCC ID:A94328040

IC ID:3232A-328040

Certificate # 1514.1

6.11. MPE calculation

The peak output power (conducted) as documented in section 6.3 of this report is 8.25dBm or 6.68mW maximum.

Maximum antenna gain was measured at 2406 MHz of 4.1 dBi.

This is less than $60/f$ (GHz) = 24 mW, therefore SAR testing is not required.

Ignoring the duty cycle (source based time averaging), at a distance of 20cm from the product (typically a table mounted device, categorized as "mobile" in FCC OET Guide65), and allowing for a 4.1dBi (2.57 numerical) antenna gain, the power density would be

$$P/\text{area} = 6.68\text{mW} \times 2.57 / 5026 \text{ cm}^2 = .0034\text{mW}/ \text{cm}^2$$

This is well below the exposure limit of $1 \text{ mW}/\text{cm}^2$ for the general population.

Without written permission of laboratory, this report shall not be reproduced except in full.