

TEST REPORT

CERTIFICATE OF CONFORMITY

Standard: 47 CFR FCC Part 15, Subpart C (Section 15.247)
Report No.: RFBAYG-WTW-P24020046-1
FCC ID: A94318
Product: Wireless Headphones
Brand: BOSE
Model No.: 318R,318L
Received Date: 2024/3/21
Test Date: 2024/3/28 ~ 2024/4/2
Issued Date: 2024/5/31

Applicant: Bose Corporation
Address: 100 The Mountain Road Framingham Massachusetts 01701-9168 United States
Issued By: Bureau Veritas Consumer Products Services (H.K.) Ltd., Taoyuan Branch
Lin Kou Laboratories
Lab Address: No. 47-2, 14th Ling, Chia Pau Vil., Lin Kou Dist., New Taipei City, Taiwan
Test Location: No. 47-2, 14th Ling, Chia Pau Vil., Lin Kou Dist., New Taipei City, Taiwan
FCC Registration / 198487 / TW2021
Designation Number:

Approved by: _____

Jeremy Lin

, Date: _____

2024/5/31

Jeremy Lin / Project Engineer

This test report consists of 74 pages in total. It may be duplicated completely for legal use with the approval of the applicant. It should not be reproduced except in full, without the written approval of our laboratory. The test results in the report only apply to the tested sample. The test results in this report are traceable to the national or international standards.



Prepared by : Jessica Cheng / Senior Specialist

This report is governed by, and incorporates by reference, the Conditions of Testing as posted at the date of issuance of this report at <http://www.bureauveritas.com/home/about-us/our-business/cps/about-us/terms-conditions/> and is intended for your exclusive use. Any copying or replication of this report to or for any other person or entity, or use of our name or trademark, is permitted only with our prior written permission. This report sets forth our findings solely with respect to the test samples identified herein. The results set forth in this report are not indicative or representative of the quality or characteristics of the lot from which a test sample was taken or any similar or identical product unless specifically and expressly noted. Our report includes all of the tests requested by you and the results thereof based upon the information that you provided to us. Measurement uncertainty is only provided upon request for accredited tests. Statements of conformity are based on simple acceptance criteria without taking measurement uncertainty into account, unless otherwise requested in writing. You have 60 days from date of issuance of this report to notify us of any material error or omission caused by our negligence or if you require measurement uncertainty; provided, however, that such notice shall be in writing and shall specifically address the issue you wish to raise. A failure to raise such issue within the prescribed time shall constitute your unqualified acceptance of the completeness of this report, the tests conducted and the correctness of the report contents.

Table of Contents

| | |
|---|-----------|
| Release Control Record | 4 |
| 1 Certificate | 5 |
| 2 Summary of Test Results | 6 |
| 2.1 Measurement Uncertainty | 6 |
| 2.2 Supplementary Information | 6 |
| 3 General Information | 7 |
| 3.1 General Description | 7 |
| 3.2 Antenna Description of EUT | 8 |
| 3.3 Channel List | 9 |
| 3.4 Test Mode Applicability and Tested Channel Detail | 10 |
| 3.5 Duty Cycle of Test Signal | 11 |
| 3.6 Test Program Used and Operation Descriptions | 13 |
| 3.7 Connection Diagram of EUT and Peripheral Devices | 13 |
| 3.8 Configuration of Peripheral Devices and Cable Connections | 14 |
| 4 Test Instruments | 15 |
| 4.1 RF Output Power | 15 |
| 4.2 Power Spectral Density | 15 |
| 4.3 6 dB Bandwidth | 15 |
| 4.4 Conducted Out of Band Emissions | 15 |
| 4.5 AC Power Conducted Emissions | 16 |
| 4.6 Unwanted Emissions below 1 GHz | 17 |
| 4.7 Unwanted Emissions above 1 GHz | 18 |
| 5 Limits of Test Items | 19 |
| 5.1 RF Output Power | 19 |
| 5.2 Power Spectral Density | 19 |
| 5.3 6 dB Bandwidth | 19 |
| 5.4 Conducted Out of Band Emissions | 19 |
| 5.5 AC Power Conducted Emissions | 19 |
| 5.6 Unwanted Emissions below 1 GHz | 19 |
| 5.7 Unwanted Emissions above 1 GHz | 20 |
| 6 Test Arrangements | 21 |
| 6.1 RF Output Power | 21 |
| 6.1.1 Test Setup | 21 |
| 6.1.2 Test Procedure | 21 |
| 6.2 Power Spectral Density | 21 |
| 6.2.1 Test Setup | 21 |
| 6.2.2 Test Procedure | 21 |
| 6.3 6 dB Bandwidth | 22 |
| 6.3.1 Test Setup | 22 |
| 6.3.2 Test Procedure | 22 |
| 6.4 Conducted Out of Band Emissions | 22 |
| 6.4.1 Test Setup | 22 |
| 6.4.2 Test Procedure | 22 |
| 6.5 AC Power Conducted Emissions | 23 |
| 6.5.1 Test Setup | 23 |
| 6.5.2 Test Procedure | 23 |
| 6.6 Unwanted Emissions below 1 GHz | 24 |
| 6.6.1 Test Setup | 24 |
| 6.6.2 Test Procedure | 25 |
| 6.7 Unwanted Emissions above 1 GHz | 26 |
| 6.7.1 Test Setup | 26 |
| 6.7.2 Test Procedure | 26 |
| 7 Test Results of Test Item | 27 |



| | | |
|----------|--|-----------|
| 7.1 | RF Output Power | 27 |
| 7.2 | Power Spectral Density | 29 |
| 7.3 | 6 dB Bandwidth | 31 |
| 7.4 | Conducted Out of Band Emissions | 33 |
| 7.5 | AC Power Conducted Emissions | 37 |
| 7.6 | Unwanted Emissions below 1 GHz | 49 |
| 7.7 | Unwanted Emissions above 1 GHz..... | 53 |
| 8 | Pictures of Test Arrangements | 73 |
| 9 | Information of the Testing Laboratories | 74 |



Release Control Record

| Issue No. | Description | Date Issued |
|------------------------|-------------------|-------------|
| RFBAYG-WTW-P24020046-1 | Original release. | 2024/5/31 |

1 Certificate

Product: Wireless Headphones

Brand: BOSE

Test Model: 318R,318L

Sample Status: Engineering sample

Applicant: Bose Corporation

Test Date: 2024/3/28 ~ 2024/4/2

Standard: 47 CFR FCC Part 15, Subpart C (Section 15.247)

Measurement ANSI C63.10-2013

procedure: KDB 558074 D01 15.247 Meas Guidance v05r02

The above equipment has been tested by **Bureau Veritas Consumer Products Services (H.K.) Ltd., Taoyuan Branch**, and found compliance with the requirement of the above standards. The test record, data evaluation & Equipment Under Test (EUT) configurations represented herein are true and accurate accounts of the measurements of the sample's RF characteristics under the conditions specified in this report.

2 Summary of Test Results

| 47 CFR FCC Part 15, Subpart C (Section 15.247) | | | |
|--|---------------------------------|--------|--|
| Standard / Clause | Test Item | Result | Remark |
| 15.247(b) | RF Output Power | Pass | Meet the requirement of limit. |
| 15.247(e) | Power Spectral Density | Pass | Meet the requirement of limit. |
| 15.247(a)(2) | 6 dB Bandwidth | Pass | Meet the requirement of limit. |
| 15.247(d) | Conducted Out of Band Emissions | Pass | Meet the requirement of limit. |
| 15.207 | AC Power Conducted Emissions | Pass | Minimum passing margin is -11.74 dB at 0.54302 MHz |
| 15.205 / 15.209 / 15.247(d) | Unwanted Emissions below 1 GHz | Pass | Minimum passing margin is -14.7 dB at 42.67 MHz |
| 15.205 / 15.209 / 15.247(d) | Unwanted Emissions above 1 GHz | Pass | Minimum passing margin is -8.9 dB at 2483.50 MHz |
| 15.203 | Antenna Requirement | Pass | No antenna connector is used. |

Note: Determining compliance based on the results of the compliance measurement, not taking into account measurement instrumentation uncertainty.

2.1 Measurement Uncertainty

Where relevant, the following measurement uncertainty levels have been estimated for tests performed on the EUT as specified in CISPR 16-4-2:

| Measurement | Specification | Expanded Uncertainty (k=2) (±) |
|---------------------------------|-----------------|-----------------------------------|
| RF Output Power | - | 1.1 dB |
| Power Spectral Density | - | 1.3 dB |
| 6 dB Bandwidth | - | 960 Hz |
| Conducted Out of Band Emissions | 9 kHz ~ 40 GHz | 2.7 dB |
| AC Power Conducted Emissions | 9 kHz ~ 30 MHz | 2.88 dB |
| Unwanted Emissions below 1 GHz | 9 kHz ~ 30 MHz | 2.85 dB |
| | 30 MHz ~ 1 GHz | 2.85 dB |
| Unwanted Emissions above 1 GHz | 1 GHz ~ 6 GHz | 3.06 dB |
| | 6 GHz ~ 18 GHz | 3.06 dB |
| | 18 GHz ~ 40 GHz | 3.29 dB |

The other instruments specified are routine verified to remain within the calibrated levels, no measurement uncertainty is required to be calculated.

2.2 Supplementary Information

There is not any deviation from the test standards for the test method, and no modifications required for compliance.

3 General Information

3.1 General Description

| | |
|-----------------------|--|
| Product | Wireless Headphones |
| Brand | BOSE |
| Test Model | 318R,318L |
| Status of EUT | Engineering sample |
| Power Supply Rating | 3.85Vdc from Battery or 5Vdc from Charging case |
| Modulation Type | GFSK |
| Modulation Technology | DTS |
| Transfer Rate | Up to 2 Mbps |
| Operating Frequency | 2.402 GHz ~ 2.48 GHz |
| Number of Channel | 40 |
| Output Power | 5.702 mW (7.56 dBm) |

Note:

1. The EUT uses following accessories.

| Charging case | | |
|--|----------|------------------------|
| Brand | Model | |
| BOSE | 442318 | |
| USB Type-C to USB-A cable | | |
| Specification | | |
| Signal Line : shielded without core,0.3m | | |
| Battery | | |
| Brand | Model | Specification |
| VDL | 1254PF4F | Rating : 3.85Vdc 70mAh |
| Battery | | |
| Brand | Model | Specification |
| Mic-power | M1254A6 | Rating : 3.85Vdc 70mAh |

2. The above EUT information is declared by manufacturer and for more detailed features description, please refer to the manufacturer's specifications or User's Manual.

3.2 Antenna Description of EUT

1. The antenna information is listed as below.

| Antenna No. | Gain (dBi) | Antenna Type | Connector Type |
|-------------|------------|--------------|----------------|
| 318L | -0.29 | PIFA | NA |
| 318R | -1.65 | PIFA | NA |

* Detail antenna specification please refer to antenna datasheet and/or antenna measurement report.

3.3 Channel List

40 channels are provided for BT-LE:

| Channel | Frequency (MHz) | Channel | Frequency (MHz) | Channel | Frequency (MHz) | Channel | Frequency (MHz) |
|---------|-----------------|---------|-----------------|---------|-----------------|---------|-----------------|
| 0 | 2402 | 10 | 2422 | 20 | 2442 | 30 | 2462 |
| 1 | 2404 | 11 | 2424 | 21 | 2444 | 31 | 2464 |
| 2 | 2406 | 12 | 2426 | 22 | 2446 | 32 | 2466 |
| 3 | 2408 | 13 | 2428 | 23 | 2448 | 33 | 2468 |
| 4 | 2410 | 14 | 2430 | 24 | 2450 | 34 | 2470 |
| 5 | 2412 | 15 | 2432 | 25 | 2452 | 35 | 2472 |
| 6 | 2414 | 16 | 2434 | 26 | 2454 | 36 | 2474 |
| 7 | 2416 | 17 | 2436 | 27 | 2456 | 37 | 2476 |
| 8 | 2418 | 18 | 2438 | 28 | 2458 | 38 | 2478 |
| 9 | 2420 | 19 | 2440 | 29 | 2460 | 39 | 2480 |

3.4 Test Mode Applicability and Tested Channel Detail

| | |
|-------------|--|
| Pre-Scan: | <p>1. EUT has Battery(1254PF4F)/ Battery(M1254A6). Pre-scan these modes and find the worst case as a representative test condition.</p> <p>2. EUT can be used in the following ways: XYZ 3-axis. Pre-scan in these ways and find the worst case as a representative test condition.</p> <p>3. For Unwanted Emission below/above 1G has A~E mode. Pre-scan these modes and find the worst case as a representative test condition.</p> <p>Pre-Scan Mode:</p> <p>Mode A(Left/Right Earphone): EUT with Charing Case(Powered from Notebook and USB Cable)</p> <p>Mode B(Left/Right Earphone): EUT with Charing Case(Powered from Adapter and USB Cable)</p> <p>Mode C(Left/Right Earphone): EUT with Charing Case(Powered from Charging Pad via Qi function)</p> <p>Mode D(Left/Right Earphone): EUT with Charing Case(Powered from internal Battery)</p> <p>Mode E(Left/Right Earphone): EUT with internal Battery</p> |
| Worst Case: | <p>1. Battery worse condition : Battery(1254PF4F).</p> <p>2. X/ Y/ Z Worst Condition: X Axis for Unwanted Emission above 1GHz and Unwanted Emission below 1GHz.</p> <p>3. For Unwanted Emission below/above 1G: Mode A(Left/Right Earphone) is the worst test configuration.</p> |

Following channel(s) was (were) selected for the final test as listed below:

| Test Item | EUT Configure Mode | Mode | Tested Channel | Modulation | Data Rate Parameter |
|--|------------------------|--|----------------|------------|---------------------|
| RF Output Power | A(Left/Right Earphone) | BT-LE 1M | 0, 19, 39 | GFSK | 1Mb/s |
| | | BT-LE 2M | 0, 19, 39 | GFSK | 2Mb/s |
| Power Spectral Density | A(Left/Right Earphone) | BT-LE 1M | 0, 19, 39 | GFSK | 1Mb/s |
| | | BT-LE 2M | 0, 19, 39 | GFSK | 2Mb/s |
| 6 dB Bandwidth / Conducted Out of Band Emissions | A(Left/Right Earphone) | BT-LE 1M | 0, 19, 39 | GFSK | 1Mb/s |
| | | BT-LE 2M | 0, 19, 39 | GFSK | 2Mb/s |
| AC Power Conducted Emissions | A(Left Earphone) | BT-LE 1M | 39 | GFSK | 1Mb/s |
| | B(Left Earphone) | BT-LE 1M | 39 | GFSK | 1Mb/s |
| | C(Left Earphone) | BT-LE 1M | 39 | GFSK | 1Mb/s |
| | A(Right Earphone) | BT-LE 1M | 0 | GFSK | 1Mb/s |
| | B(Right Earphone) | BT-LE 1M | 0 | GFSK | 1Mb/s |
| | C(Right Earphone) | BT-LE 1M | 0 | GFSK | 1Mb/s |
| Unwanted Emissions below 1 GHz | A(Left Earphone) | BT-LE 1M | 39 | GFSK | 1Mb/s |
| | A(Right Earphone) | BT-LE 1M | 0 | GFSK | 1Mb/s |
| Unwanted Emissions above 1 GHz | A(Left Earphone) | BT-LE 1M | 0, 19, 39 | GFSK | 1Mb/s |
| | | BT-LE 2M | 0, 19, 39 | GFSK | 2Mb/s |
| | A(Right Earphone) | BT-LE 1M | 0, 19, 39 | GFSK | 1Mb/s |
| | | BT-LE 2M | 0, 19, 39 | GFSK | 2Mb/s |
| EUT Configure Mode: | A(Left/Right Earphone) | EUT with Charing Case(Powered from Notebook and USB Cable) | | | |
| | B(Left/Right Earphone) | EUT with Charing Case(Powered from Adapter and USB Cable) | | | |
| | C(Left/Right Earphone) | EUT with Charing Case(Powered from Charging Pad via Qi function) | | | |

3.5 Duty Cycle of Test Signal

A(Left Earphone)

BT-LE 1M: Duty cycle = $0.38 \text{ ms} / 0.625 \text{ ms} \times 100\% = 60.8\%$, duty factor = $10 * \log (1/\text{Duty cycle}) = 2.16 \text{ dB}$

BT-LE 2M: Duty cycle = $1.069 \text{ ms} / 2.499 \text{ ms} \times 100\% = 42.8\%$, duty factor = $10 * \log (1/\text{Duty cycle}) = 3.69 \text{ dB}$

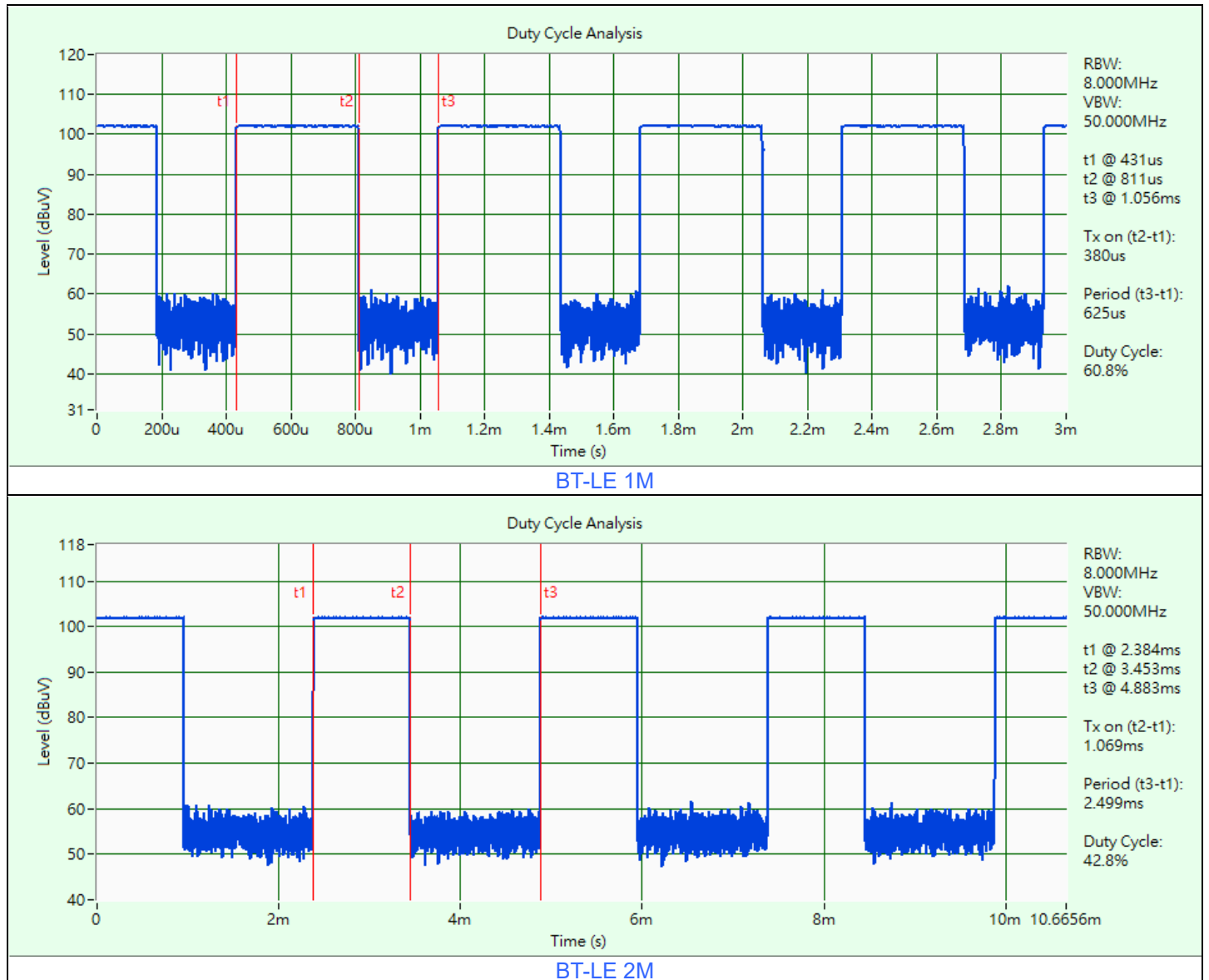

A(Right Earphone)

BT-LE 1M: Duty cycle = $0.379 \text{ ms} / 0.624 \text{ ms} \times 100\% = 60.7\%$, duty factor = $10 * \log (1/\text{Duty cycle}) = 2.17 \text{ dB}$

BT-LE 2M: Duty cycle = $1.069 \text{ ms} / 2.499 \text{ ms} \times 100\% = 42.8\%$, duty factor = $10 * \log (1/\text{Duty cycle}) = 3.69 \text{ dB}$

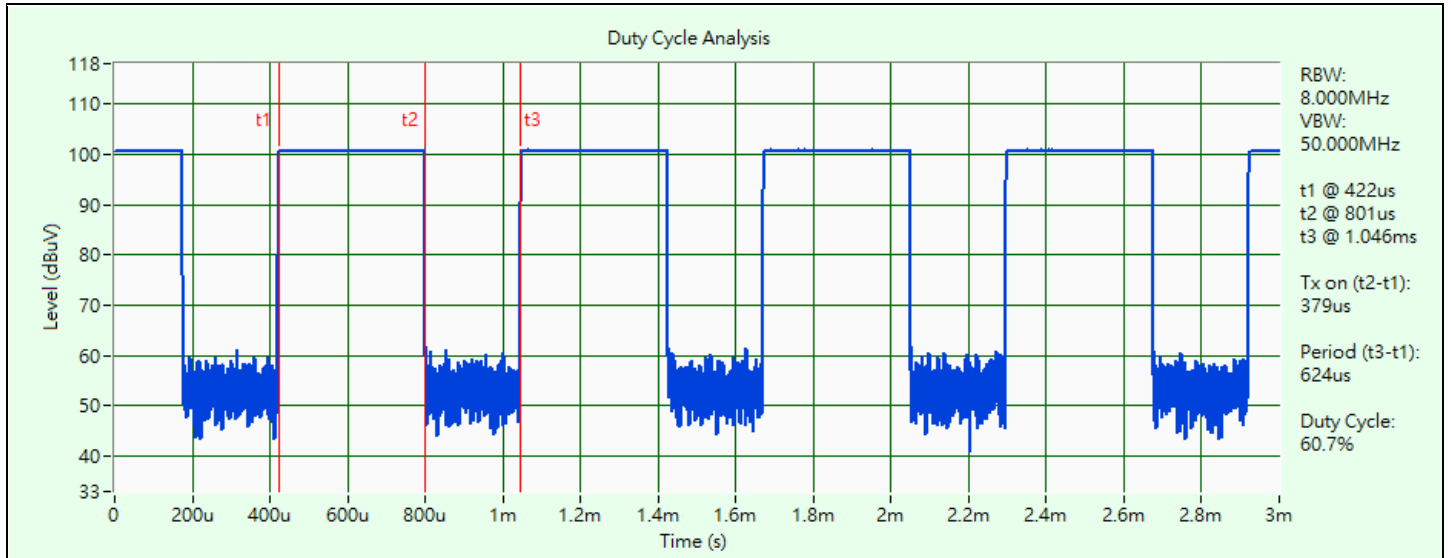

BT-LE 1M

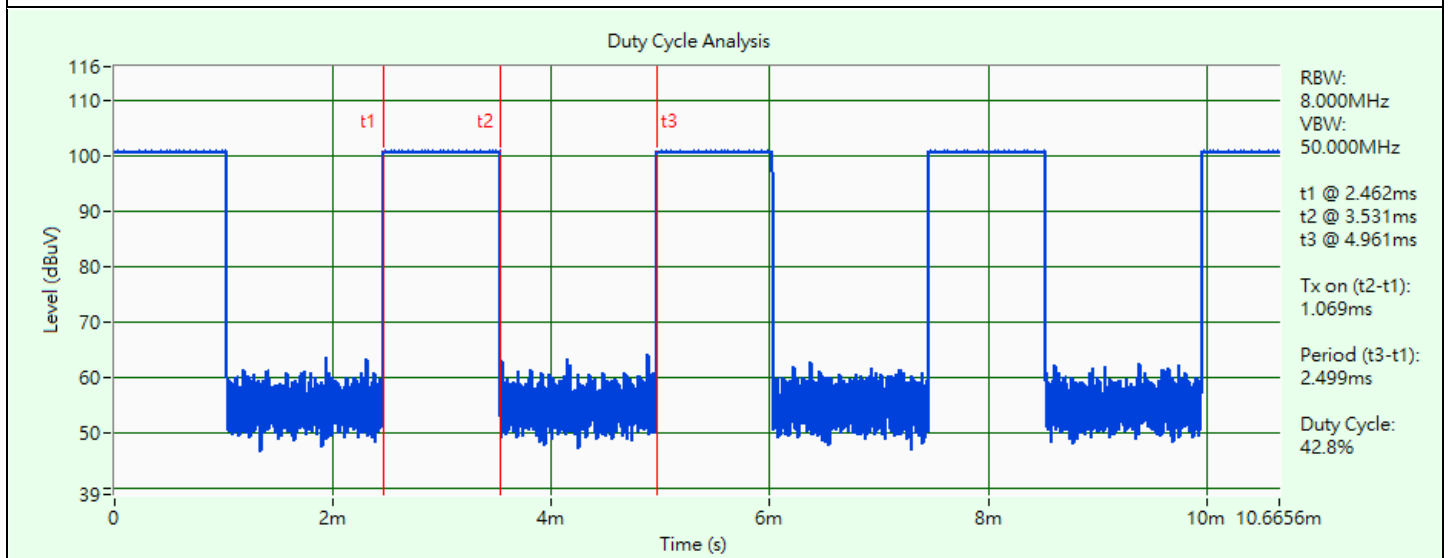

BT-LE 2M

3.6 Test Program Used and Operation Descriptions

Controlling software (AB158x_Airoha_Tool_Kit(ATK)_v3.4.4) has been activated to set the EUT under transmission condition continuously at specific channel frequency.

3.7 Connection Diagram of EUT and Peripheral Devices

A(Left/Right Earphone)

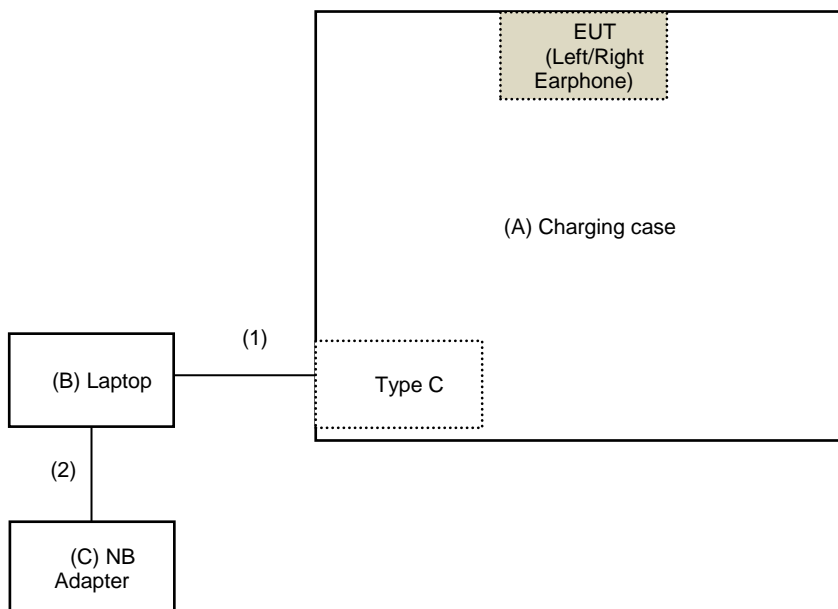

Remote Site

B(Left/Right Earphone)

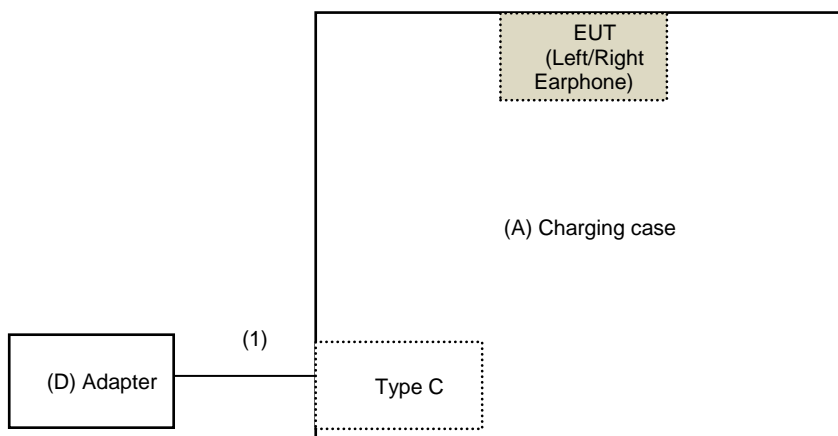

Remote Site

C(Left/Right Earphone)

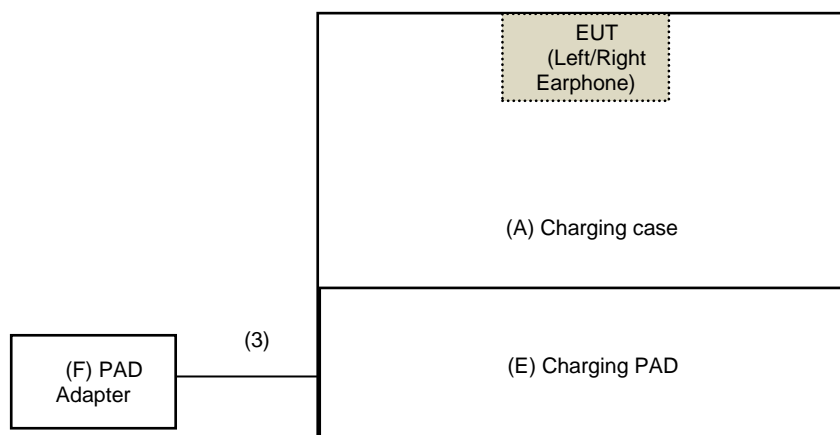

Remote Site

3.8 Configuration of Peripheral Devices and Cable Connections

| ID | Product | Brand | Model No. | Serial No. | FCC ID | Remarks |
|----|---------------|--------|----------------------------|------------|-----------|-----------------------|
| A | Charging Case | BOSE | 442318 | N/A | A94442318 | Supplied by applicant |
| B | Laptop | Lenovo | 81A4 | YD02TWDP | N/A | Provided by Lab |
| C | NB Adapter | Lenovo | ADLX65CLGU2A | N/A | N/A | Provided by Lab |
| D | Adapter | BOSE | F5V-1.6C-1U-US | N/A | N/A | Supplied by applicant |
| E | Charging PAD | belkin | F7U027 | N/A | N/A | Provided by Lab |
| F | PAD Adapter | belkin | ADS-26FSG-12 150223EPCU | N/A | N/A | Provided by Lab |

| ID | Cable Descriptions | Qty. | Length (m) | Shielding (Yes/No) | Cores (Qty.) | Remarks |
|----|----------------------|------|------------|--------------------|--------------|-----------------------|
| 1 | Type-C Cable | 1 | 0.3 | Y | 0 | Supplied by applicant |
| 2 | NB Adapter DC cable | 1 | 1.9 | N | 0 | Provided by Lab |
| 3 | PAD Adapter DC cable | 1 | 1.5 | N | 0 | Provided by Lab |

4 Test Instruments

The calibration interval of the all test instruments are 12 months and the calibrations are traceable to NML/ROC and NIST/USA.

4.1 RF Output Power

| Description Manufacturer | Model No. | Serial No. | Calibrated Date | Calibrated Until |
|---------------------------------------|-----------|-------------|--------------------|---------------------|
| Pulse Power Sensor Anritsu | MA2411B | 0738404 | 2023/5/5 | 2024/5/4 |
| RF Power Meter Anritsu | ML2495A | 0842014 | 2023/5/5 | 2024/5/4 |
| USB Wideband Power Sensor Keysight | U2021XA | U2021XA_001 | 2023/6/6 | 2024/6/5 |

Notes:

1. The test was performed in LK - Oven
2. Tested Date: 2024/4/2

4.2 Power Spectral Density

| Description Manufacturer | Model No. | Serial No. | Calibrated Date | Calibrated Until |
|---------------------------------|----------------------------------|------------|--------------------|---------------------|
| PXA Signal Analyzer Keysight | N9030A | MY54490260 | 2023/7/13 | 2024/7/12 |
| Signal Analyzer R&S | FSV40 | 101042 | 2023/9/5 | 2024/9/4 |
| Software | ADT_RF Test Software V6.6.5.4 | N/A | N/A | N/A |

Notes:

1. The test was performed in LK - Oven
2. Tested Date: 2024/4/2

4.3 6 dB Bandwidth

Refer to section 4.2 to get information of the instruments.

4.4 Conducted Out of Band Emissions

Refer to section 4.2 to get information of the instruments.

4.5 AC Power Conducted Emissions

| Description Manufacturer | Model No. | Serial No. | Calibrated Date | Calibrated Until |
|--------------------------------------|---------------|--------------|--------------------|---------------------|
| 50 ohm terminal resistance LYNICS | 0900510 | E1-01-305 | 2024/2/6 | 2025/2/5 |
| | | E1-011285 | 2023/9/21 | 2024/9/20 |
| | | E1-011286 | 2023/9/21 | 2024/9/20 |
| EMI Test Receiver R&S | ESCS 30 | 100276 | 2023/4/20 | 2024/4/19 |
| | ESR3 | 102412 | 2023/12/25 | 2024/12/24 |
| Fixed Attenuator STI | STI02-2200-10 | NO.4 | 2023/9/1 | 2024/8/31 |
| High Voltage Probe Schwarzbeck | TK9420 | 00982 | 2023/12/11 | 2024/12/10 |
| LISN R&S | ENV216 | 101197 | 2023/7/12 | 2024/7/11 |
| LISN Schwarzbeck | NNLK 8121 | 8121-731 | 2023/6/9 | 2024/6/8 |
| | | 8121-808 | 2023/5/2 | 2024/5/1 |
| | NNLK 8129 | 8129229 | 2023/6/27 | 2024/6/26 |
| | NSLK 8128 | 8128-244 | 2023/11/10 | 2024/11/9 |
| RF Coaxial Cable PEWC | 5D-FB | Cable-CO5-01 | 2024/1/18 | 2025/1/17 |
| Software BVADT | Cond_V7.4.1.0 | N/A | N/A | N/A |

Notes:

1. The test was performed in Linkou Conduction 5.
2. Tested Date: 2024/4/2

4.6 Unwanted Emissions below 1 GHz

| Description Manufacturer | Model No. | Serial No. | Calibrated Date | Calibrated Until |
|--|------------------|--------------|--------------------|---------------------|
| Bi_Log Antenna Schwarzbeck | VULB 9168 | 137 | 2023/10/13 | 2024/10/12 |
| Coupling / Decoupling Network Schwarzbeck | CDNE-M2 | 00097 | 2023/5/25 | 2024/5/24 |
| | CDNE-M3 | 00091 | 2023/5/25 | 2024/5/24 |
| Loop Antenna EMCI | LPA600 | 270 | 2023/9/4 | 2024/9/3 |
| MXE EMI Receiver Agilent | N9038A | MY51210129 | 2024/3/22 | 2025/3/21 |
| | | MY51210137 | 2023/6/5 | 2024/6/4 |
| Preamplifier Agilent | 8447D | 2944A11064 | 2024/2/15 | 2025/2/14 |
| Preamplifier EMCI | EMC001340 | 980269 | 2023/6/27 | 2024/6/26 |
| RF Coaxial Cable Pacific | 8D-FB | Cable-CH6-02 | 2023/6/27 | 2024/6/26 |
| Signal Analyzer R&S | FSV40 | 101544 | 2023/5/9 | 2024/5/8 |
| Software BVADT | Radiated_V8.7.08 | N/A | N/A | N/A |
| Tower ADT | AT100 | 0306 | N/A | N/A |
| Turn Table ADT | TT100 | 0306 | N/A | N/A |

Notes:

1. The test was performed in Linkou 966 Chamber 6 (CH 6).
2. Tested Date: 2024/3/28

4.7 Unwanted Emissions above 1 GHz

| Description Manufacturer | Model No. | Serial No. | Calibrated Date | Calibrated Until |
|---------------------------------------|---------------------|--------------|--------------------|---------------------|
| Boresight antenna tower fixture BV | BAF-02 | 6 | N/A | N/A |
| High Pass Filter Wainwright | WHK 3.1/18G-10SS | SN 8 | 2023/5/25 | 2024/5/24 |
| Horn Antenna EMCO | 3115 | 00028257 | 2023/11/12 | 2024/11/11 |
| Horn Antenna ETS-Lindgren | 3117-PA | 00215857 | 2023/11/12 | 2024/11/11 |
| Horn Antenna Schwarzbeck | BBHA 9170 | 212 | 2023/10/16 | 2024/10/15 |
| | | BBHA9170241 | 2023/10/16 | 2024/10/15 |
| MXE EMI Receiver Agilent | N9038A | MY51210129 | 2024/3/22 | 2025/3/21 |
| | | MY51210137 | 2023/6/5 | 2024/6/4 |
| Notch Filter Micro-Tronics | BRC50703-01 | 010 | 2023/5/25 | 2024/5/24 |
| | BRM17690 | 005 | 2023/5/25 | 2024/5/24 |
| Preamplifier EMCI | EMC0126545 | 980076 | 2024/2/15 | 2025/2/14 |
| | EMC184045B | 980175 | 2023/9/2 | 2024/9/1 |
| | | 980235 | 2024/2/15 | 2025/2/14 |
| Preamplifier HP | 8449B | 3008A01201 | 2024/2/15 | 2025/2/14 |
| RF Coaxial Cable EMCI | EMC102-KM-KM-1000 | 200310 | 2024/3/11 | 2025/3/10 |
| | EMC104 | 190801 | 2023/9/13 | 2024/9/12 |
| | | 190804 | 2023/9/13 | 2024/9/12 |
| RF Coaxial Cable HUBER+SUHNER | SF-104 | Cable-CH6-01 | 2023/9/13 | 2024/9/12 |
| Signal Analyzer R&S | FSV40 | 101042 | 2023/9/5 | 2024/9/4 |
| | | 101544 | 2023/5/9 | 2024/5/8 |
| Software BVADT | Radiated_V7.7.1.1.1 | N/A | N/A | N/A |
| Tower ADT | AT100 | 0306 | N/A | N/A |
| Turn Table ADT | TT100 | 0306 | N/A | N/A |

Notes:

1. The test was performed in Linkou 966 Chamber 6 (CH 6).
2. Tested Date: 2024/3/28 ~ 2024/4/2

5 Limits of Test Items

5.1 RF Output Power

For systems using digital modulation in the 2400–2483.5 MHz bands: 1 Watt (30 dBm)

5.2 Power Spectral Density

The Maximum of Power Spectral Density Measurement is 8 dBm in any 3 kHz.

5.3 6 dB Bandwidth

The minimum of 6 dB Bandwidth Measurement is 0.5 MHz.

5.4 Conducted Out of Band Emissions

Below 20 dB of the highest emission level of operating band (in 100 kHz Resolution Bandwidth).

5.5 AC Power Conducted Emissions

| Frequency (MHz) | Conducted Limit (dBuV) | |
|-----------------|------------------------|---------|
| | Quasi-peak | Average |
| 0.15 - 0.5 | 66 - 56 | 56 - 46 |
| 0.50 - 5.0 | 56 | 46 |
| 5.0 - 30.0 | 60 | 50 |

Notes:

1. The lower limit shall apply at the transition frequencies.
2. The limit decreases in line with the logarithm of the frequency in the range of 0.15 to 0.50 MHz.

5.6 Unwanted Emissions below 1 GHz

Radiated emissions up to 1 GHz which fall in the restricted bands must comply with the radiated emission limits specified as below table. Other emissions shall be at least 20 dB below the highest level of the desired power:

| Frequencies (MHz) | Field Strength (microvolts/meter) | Measurement Distance (meters) |
|-------------------|-----------------------------------|-------------------------------|
| 0.009 ~ 0.490 | 2400/F(kHz) | 300 |
| 0.490 ~ 1.705 | 24000/F(kHz) | 30 |
| 1.705 ~ 30.0 | 30 | 30 |
| 30 ~ 88 | 100 | 3 |
| 88 ~ 216 | 150 | 3 |
| 216 ~ 960 | 200 | 3 |
| Above 960 | 500 | 3 |

Notes:

1. The lower limit shall apply at the transition frequencies.
2. Emission level (dBuV/m) = 20 log Emission level (uV/m).

5.7 Unwanted Emissions above 1 GHz

Radiated emissions above 1 GHz which fall in the restricted bands must comply with the radiated emission limits specified as below table. Other emissions shall be at least 20 dB below the highest level of the desired power:

| Frequencies (MHz) | Field Strength (microvolts/meter) | Measurement Distance (meters) |
|----------------------|--------------------------------------|----------------------------------|
| Above 960 | 500 | 3 |

Notes:

1. The lower limit shall apply at the transition frequencies.
2. Emission level (dBuV/m) = 20 log Emission level (uV/m).
3. For frequencies above 1000 MHz, the field strength limits are based on average detector, however, the peak field strength of any emission shall not exceed the maximum permitted average limits, specified above by more than 20 dB under any condition of modulation.

6 Test Arrangements

6.1 RF Output Power

6.1.1 Test Setup

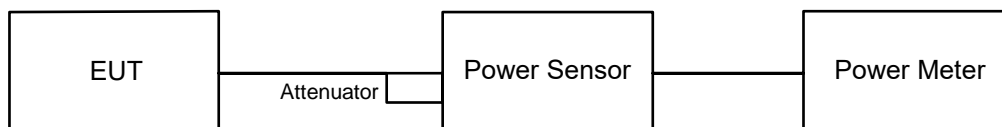

6.1.2 Test Procedure

Peak Power:

A peak power sensor was used on the output port of the EUT. A power meter was used to read the response of the peak power sensor. Record the power level.

Average Power:

Average power sensor was used to perform output power measurement, trigger and gating function of wide band power meter is enabled to measure max output power of TX on burst. Duty factor is not added to measured value.

6.2 Power Spectral Density

6.2.1 Test Setup

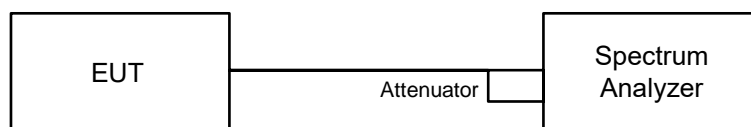

6.2.2 Test Procedure

- a. Set analyzer center frequency to DTS channel center frequency.
- b. Set the span to 1.5 times the DTS bandwidth.
- c. Set the RBW to: 3 kHz.
- d. Set the VBW $\geq 3 \times$ RBW.
- e. Detector = peak.
- f. Sweep time = auto couple.
- g. Trace mode = max hold.
- h. Allow trace to fully stabilize.
- i. Use the peak marker function to determine the maximum amplitude level within the RBW.

6.3 6 dB Bandwidth

6.3.1 Test Setup

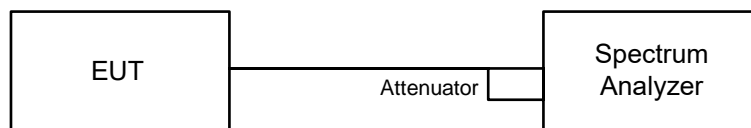

6.3.2 Test Procedure

- Set resolution bandwidth (RBW) = 100 kHz.
- Set the video bandwidth (VBW) $\geq 3 \times$ RBW, Detector = Peak.
- Trace mode = max hold.
- Sweep = auto couple.
- Measure the maximum width of the emission that is constrained by the frequencies associated with the two amplitude points (upper and lower) that are attenuated by 6 dB relative to the maximum level measured in the fundamental emission.

6.4 Conducted Out of Band Emissions

6.4.1 Test Setup

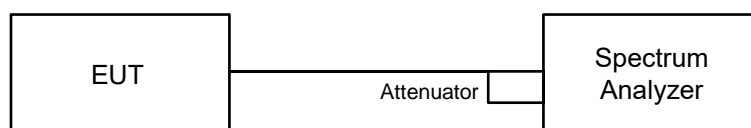

6.4.2 Test Procedure

MEASUREMENT PROCEDURE REF

- Set the RBW = 100 kHz.
- Set the VBW ≥ 300 kHz.
- Detector = peak.
- Sweep time = auto couple.
- Trace mode = max hold.
- Allow trace to fully stabilize.
- Use the peak marker function to determine the maximum power level in any 100 kHz band segment within the fundamental EBW.

MEASUREMENT PROCEDURE OOB

- Set RBW = 100 kHz.
- Set VBW ≥ 300 kHz.
- Detector = peak.
- Sweep = auto couple.
- Trace Mode = max hold.
- Allow trace to fully stabilize.
- Use the peak marker function to determine the maximum amplitude level.

6.5 AC Power Conducted Emissions

6.5.1 Test Setup

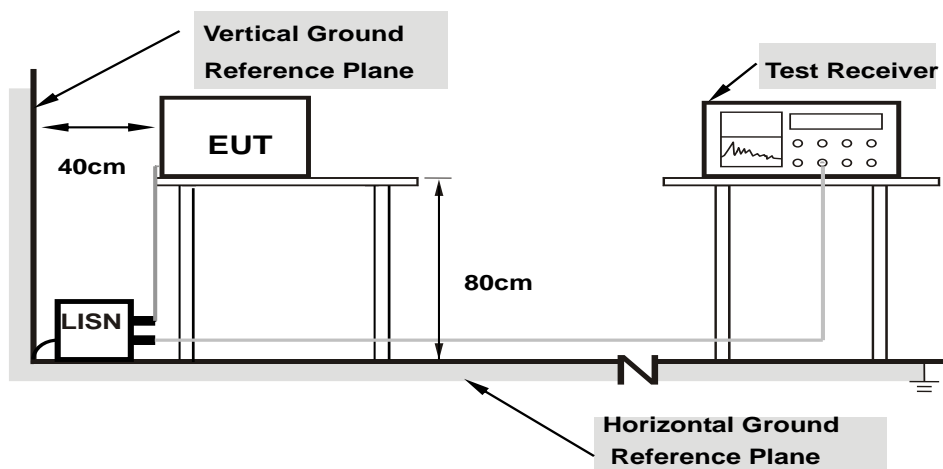

Note: 1.Support units were connected to second LISN.

For the actual test configuration, please refer to the attached file (Test Setup Photo).

6.5.2 Test Procedure

- The EUT was placed on a 0.8 meter to the top of table and placed 0.4 meters from the conducting wall of the shielded room with EUT being connected to the power mains through a line impedance stabilization network (LISN). Other support units were connected to the power mains through another LISN. The two LISNs provide 50 ohm/ 50 uH of coupling impedance for the measuring instrument.
- Both lines of the power mains connected to the EUT were checked for maximum conducted interference.
- The frequency range from 150 kHz to 30 MHz was searched. Emission levels under (Limit – 20 dB) was not recorded.

Note: The resolution bandwidth and video bandwidth of test receiver is 9 kHz for quasi-peak detection (QP) and average detection (AV) at frequency 0.15 MHz-30 MHz.

6.6 Unwanted Emissions below 1 GHz

6.6.1 Test Setup

For Radiated emission below 30 MHz

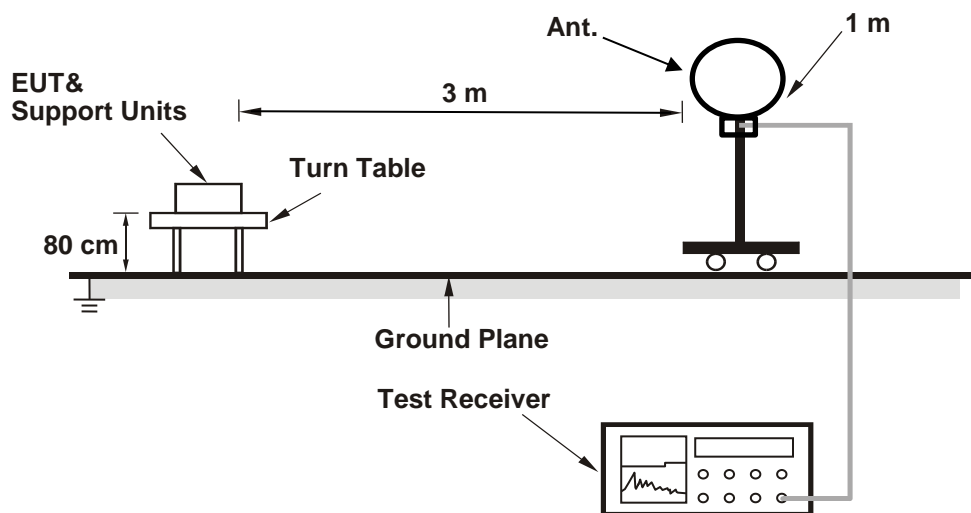

For Radiated emission above 30 MHz

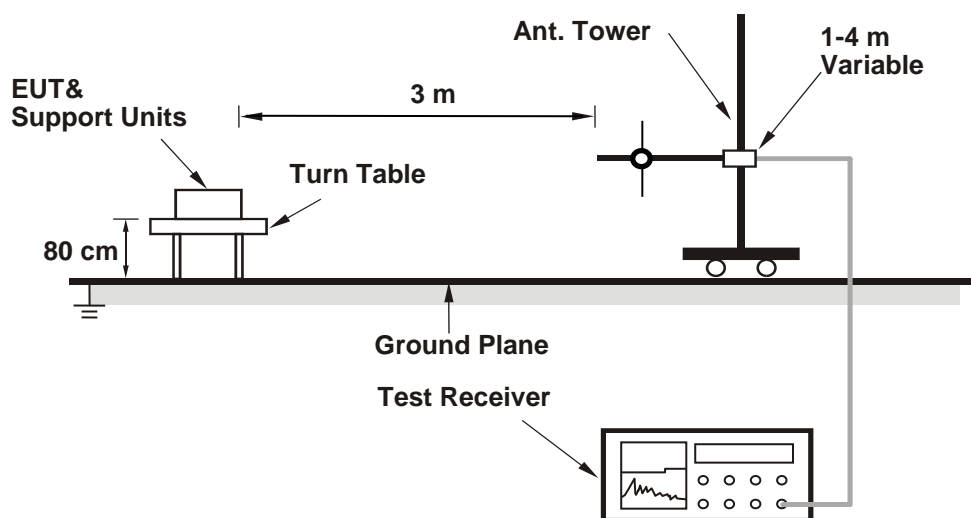

For the actual test configuration, please refer to the attached file (Test Setup Photo).

6.6.2 Test Procedure

For Radiated emission below 30 MHz

- a. The EUT was placed on the top of a rotating table 0.8 meters above the ground at 3 meter chamber room for test. The table was rotated 360 degrees to determine the position of the highest radiation.
- b. The EUT was set 3 meters away from the interference-receiving antenna, which was mounted on the top of a variable-height antenna tower.
- c. Parallel, perpendicular, and ground-parallel orientations of the antenna are set to make the measurement.
- d. For each suspected emission, the EUT was arranged to its worst case and the rotatable table was turned from 0 degrees to 360 degrees to find the maximum reading.
- e. The test-receiver system was set to Quasi-Peak Detect Function and Specified Bandwidth with Maximum Hold Mode, except for the frequency band (9 kHz to 90 kHz and 110 kHz to 490 kHz) set to average detect function and peak detect function.

Notes:

1. The resolution bandwidth and video bandwidth of test receiver/spectrum analyzer is 200 Hz at frequency below 150 kHz.
2. The resolution bandwidth and video bandwidth of test receiver/spectrum analyzer is 9 kHz or 10 kHz at frequency (150 kHz to 30 MHz).
3. All modes of operation were investigated and the worst-case emissions are reported.

For Radiated emission above 30 MHz

- a. The EUT was placed on the top of a rotating table 0.8 meters above the ground at 3 meter chamber room for test. The table was rotated 360 degrees to determine the position of the highest radiation.
- b. The EUT was set 3 meters away from the interference-receiving antenna, which was mounted on the top of a variable-height antenna tower.
- c. The height of antenna is varied from one meter to four meters above the ground to determine the maximum value of the field strength. Both horizontal and vertical polarizations of the antenna are set to make the measurement.
- d. For each suspected emission, the EUT was arranged to its worst case and then the antenna was tuned to heights from 1 meter to 4 meters and the rotatable table was turned from 0 degrees to 360 degrees to find the maximum reading.
- e. The test-receiver system was set to quasi-peak detect function and specified bandwidth with maximum hold mode when the test frequency is below 1 GHz.

Notes:

1. The resolution bandwidth and video bandwidth of test receiver/spectrum analyzer is 120 kHz for Quasi-peak detection (QP) at frequency below 1 GHz.
2. All modes of operation were investigated and the worst-case emissions are reported.

6.7 Unwanted Emissions above 1 GHz

6.7.1 Test Setup

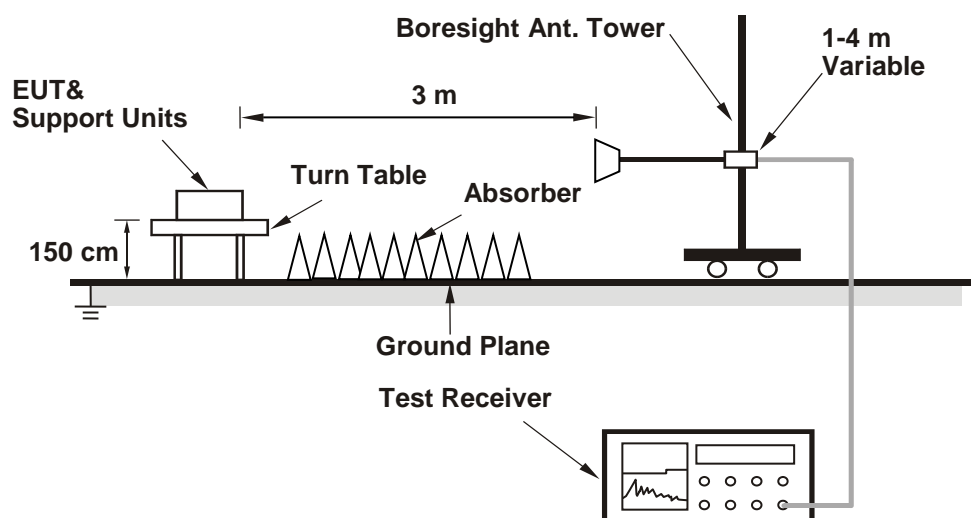

For the actual test configuration, please refer to the attached file (Test Setup Photo).

6.7.2 Test Procedure

- The EUT was placed on the top of a rotating table 1.5 meters above the ground at 3 meter chamber room for test. The table was rotated 360 degrees to determine the position of the highest radiation.
- The EUT was set 3 meters away from the interference-receiving antenna, which was mounted on the top of a variable-height antenna tower.
- The height of antenna is varied from one meter to four meters above the ground to determine the maximum value of the field strength. Both horizontal and vertical polarizations of the antenna are set to make the measurement.
- For each suspected emission, the EUT was arranged to its worst case and then the antenna was tuned to heights from 1 meter to 4 meters and the rotatable table was turned from 0 degrees to 360 degrees to find the maximum reading.
- The test-receiver/spectrum analyzer was set to peak and average detects function and specified bandwidth with maximum hold mode when the test frequency is above 1 GHz. If the peak reading value also meets average limit, measurement with the average detector is unnecessary.

Notes:

- The resolution bandwidth of test receiver/spectrum analyzer is 1 MHz and the video bandwidth is 3 MHz for Peak detection (PK) and Average detection (AV) at frequency above 1 GHz.
- For harmonic signal measurement, the resolution bandwidth of test receiver/spectrum analyzer is 1 MHz and the video bandwidth is $\geq 1/T$ (Duty cycle $< 98\%$) or 10 Hz (Duty cycle $\geq 98\%$) for Average detection (AV) at frequency above 1 GHz.
- All modes of operation were investigated and the worst-case emissions are reported.

7 Test Results of Test Item

7.1 RF Output Power

| | | | | | |
|--------------|----------------|---------------------------|--------------|------------|-----------|
| Input Power: | 120 Vac, 60 Hz | Environmental Conditions: | 25°C, 76% RH | Tested By: | Dalen Dai |
|--------------|----------------|---------------------------|--------------|------------|-----------|

A(Left Earphone)

For Peak Power

BT-LE 1M

| Chan. | Chan. Freq. (MHz) | Peak Power (mW) | Peak Power (dBm) | Power Limit (dBm) | Test Result |
|-------|-------------------|-----------------|------------------|-------------------|-------------|
| 0 | 2402 | 5.572 | 7.46 | 30 | Pass |
| 19 | 2440 | 5.623 | 7.50 | 30 | Pass |
| 39 | 2480 | 5.702 | 7.56 | 30 | Pass |

Note: The antenna gain is -0.29 dBi < 6 dBi, so the output power limit shall not be reduced.

BT-LE 2M

| Chan. | Chan. Freq. (MHz) | Peak Power (mW) | Peak Power (dBm) | Power Limit (dBm) | Test Result |
|-------|-------------------|-----------------|------------------|-------------------|-------------|
| 0 | 2402 | 5.546 | 7.44 | 30 | Pass |
| 19 | 2440 | 5.598 | 7.48 | 30 | Pass |
| 39 | 2480 | 5.662 | 7.53 | 30 | Pass |

Note: The antenna gain is -0.29 dBi < 6 dBi, so the output power limit shall not be reduced.

For Average Power

BT-LE 1M

| Chan. | Chan. Freq. (MHz) | Average Power (mW) | Average Power (dBm) |
|-------|-------------------|--------------------|---------------------|
| 0 | 2402 | 5.408 | 7.33 |
| 19 | 2440 | 5.47 | 7.38 |
| 39 | 2480 | 5.534 | 7.43 |

BT-LE 2M

| Chan. | Chan. Freq. (MHz) | Average Power (mW) | Average Power (dBm) |
|-------|-------------------|--------------------|---------------------|
| 0 | 2402 | 5.383 | 7.31 |
| 19 | 2440 | 5.445 | 7.36 |
| 39 | 2480 | 5.495 | 7.40 |

| | | | | | |
|--------------|----------------|---------------------------|--------------|------------|-----------|
| Input Power: | 120 Vac, 60 Hz | Environmental Conditions: | 25°C, 76% RH | Tested By: | Dalen Dai |
|--------------|----------------|---------------------------|--------------|------------|-----------|

A(Right Earphone)

For Peak Power

BT-LE 1M

| Chan. | Chan. Freq. (MHz) | Peak Power (mW) | Peak Power (dBm) | Power Limit (dBm) | Test Result |
|-------|-------------------|-----------------|------------------|-------------------|-------------|
| 0 | 2402 | 5.623 | 7.50 | 30 | Pass |
| 19 | 2440 | 5.559 | 7.45 | 30 | Pass |
| 39 | 2480 | 5.272 | 7.22 | 30 | Pass |

Note: The antenna gain is -1.65 dBi < 6 dBi, so the output power limit shall not be reduced.

BT-LE 2M

| Chan. | Chan. Freq. (MHz) | Peak Power (mW) | Peak Power (dBm) | Power Limit (dBm) | Test Result |
|-------|-------------------|-----------------|------------------|-------------------|-------------|
| 0 | 2402 | 5.61 | 7.49 | 30 | Pass |
| 19 | 2440 | 5.559 | 7.45 | 30 | Pass |
| 39 | 2480 | 5.272 | 7.22 | 30 | Pass |

Note: The antenna gain is -1.65 dBi < 6 dBi, so the output power limit shall not be reduced.

For Average Power

BT-LE 1M

| Chan. | Chan. Freq. (MHz) | Average Power (mW) | Average Power (dBm) |
|-------|-------------------|--------------------|---------------------|
| 0 | 2402 | 5.47 | 7.38 |
| 19 | 2440 | 5.42 | 7.34 |
| 39 | 2480 | 5.14 | 7.11 |

BT-LE 2M

| Chan. | Chan. Freq. (MHz) | Average Power (mW) | Average Power (dBm) |
|-------|-------------------|--------------------|---------------------|
| 0 | 2402 | 5.445 | 7.36 |
| 19 | 2440 | 5.395 | 7.32 |
| 39 | 2480 | 5.117 | 7.09 |

7.2 Power Spectral Density

| | | | | | |
|--------------|----------------|---------------------------|--------------|------------|-----------|
| Input Power: | 120 Vac, 60 Hz | Environmental Conditions: | 25°C, 76% RH | Tested By: | Dalen Dai |
|--------------|----------------|---------------------------|--------------|------------|-----------|

A(Left Earphone)

BT-LE 1M

| TX chain | Channel | Freq. (MHz) | PSD (dBm/3kHz) | PSD Limit (dBm/3kHz) | Pass / Fail |
|----------|---------|-------------|----------------|----------------------|-------------|
| Chain 0 | 0 | 2402 | -8.41 | 8 | Pass |
| | 19 | 2440 | -8.29 | 8 | Pass |
| | 39 | 2480 | -8.25 | 8 | Pass |

Note: The antenna gain is -0.29 dBi < 6 dBi, so the power density limit shall not be reduced.

BT-LE 2M

| TX chain | Channel | Freq. (MHz) | PSD (dBm/3kHz) | PSD Limit (dBm/3kHz) | Pass / Fail |
|----------|---------|-------------|----------------|----------------------|-------------|
| Chain 0 | 0 | 2402 | -12.3 | 8 | Pass |
| | 19 | 2440 | -12.17 | 8 | Pass |
| | 39 | 2480 | -12.09 | 8 | Pass |

Note: The antenna gain is -0.29 dBi < 6 dBi, so the power density limit shall not be reduced.

Spectrum Plot of Maximum Value

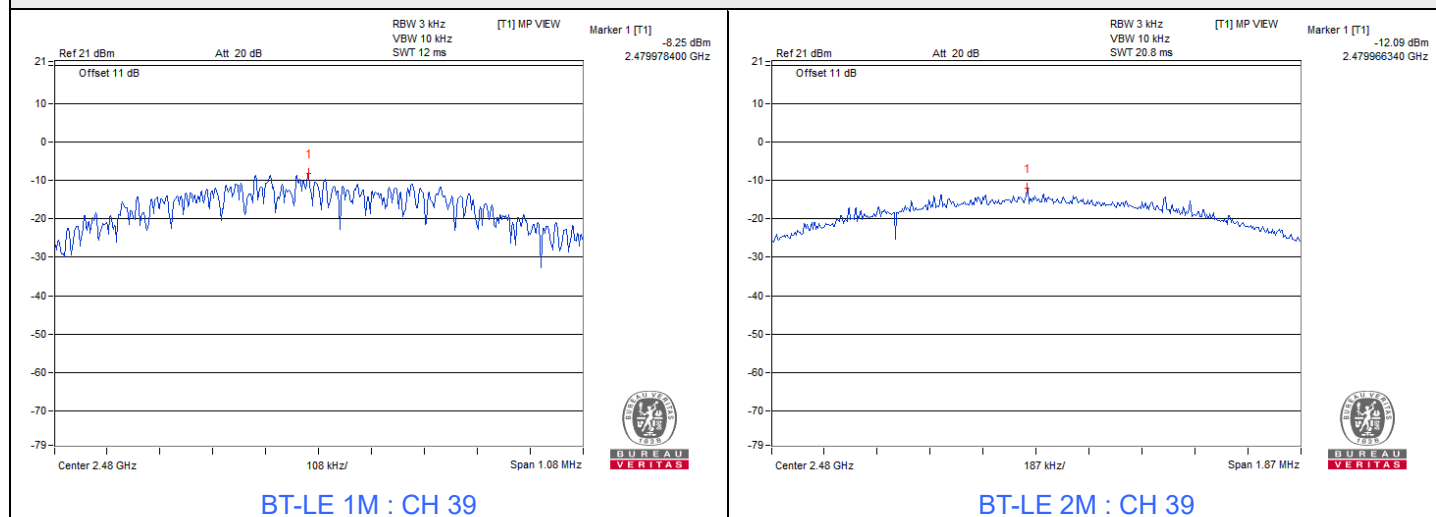

| | | | | | |
|--------------|----------------|---------------------------|--------------|------------|-----------|
| Input Power: | 120 Vac, 60 Hz | Environmental Conditions: | 25°C, 76% RH | Tested By: | Dalen Dai |
|--------------|----------------|---------------------------|--------------|------------|-----------|

A(Right Earphone)

BT-LE 1M

| TX chain | Channel | Freq. (MHz) | PSD (dBm/3kHz) | PSD Limit (dBm/3kHz) | Pass / Fail |
|----------|---------|-------------|----------------|----------------------|-------------|
| Chain 0 | 0 | 2402 | -8.35 | 8 | Pass |
| | 19 | 2440 | -8.37 | 8 | Pass |
| | 39 | 2480 | -8.56 | 8 | Pass |

Note: The antenna gain is -1.65 dBi < 6 dBi, so the power density limit shall not be reduced.

BT-LE 2M

| TX chain | Channel | Freq. (MHz) | PSD (dBm/3kHz) | PSD Limit (dBm/3kHz) | Pass / Fail |
|----------|---------|-------------|----------------|----------------------|-------------|
| Chain 0 | 0 | 2402 | -12.2 | 8 | Pass |
| | 19 | 2440 | -12.33 | 8 | Pass |
| | 39 | 2480 | -12.41 | 8 | Pass |

Note: The antenna gain is -1.65 dBi < 6 dBi, so the power density limit shall not be reduced.

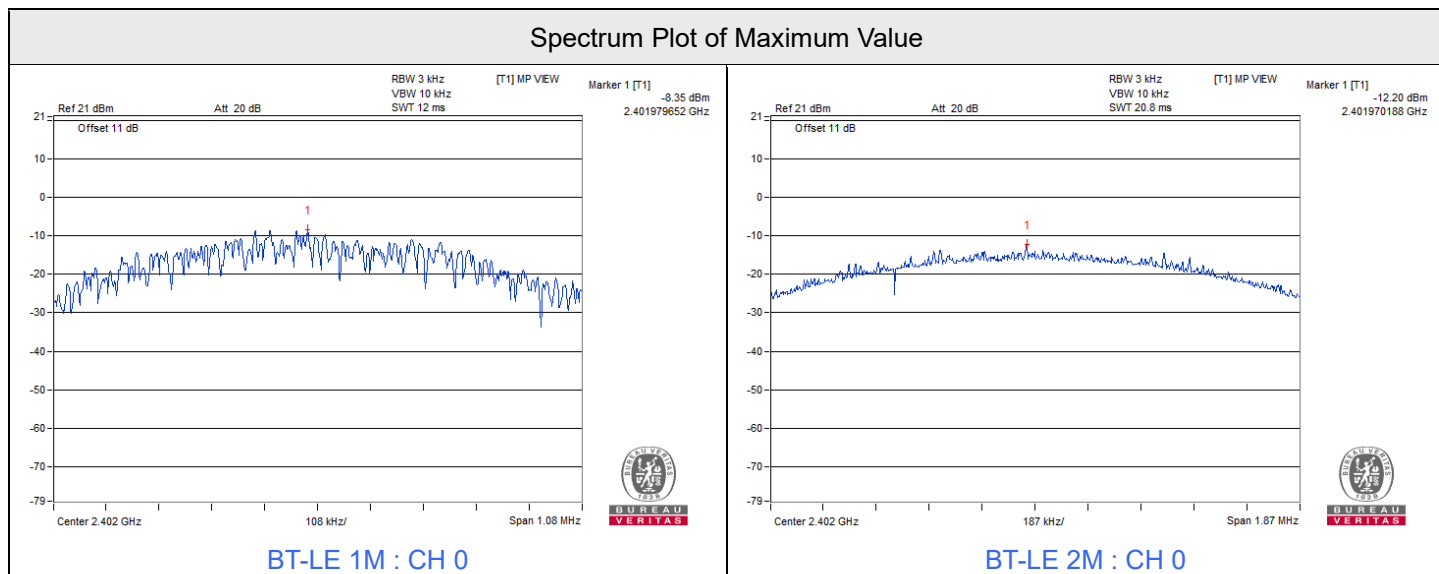

7.3 6 dB Bandwidth

| | | | | | |
|--------------|----------------|---------------------------|--------------|------------|-----------|
| Input Power: | 120 Vac, 60 Hz | Environmental Conditions: | 25°C, 76% RH | Tested By: | Dalen Dai |
|--------------|----------------|---------------------------|--------------|------------|-----------|

A(Left Earphone)

BT-LE 1M

| Channel | Frequency (MHz) | 6 dB Bandwidth (MHz) | Minimum Limit (MHz) | Test Result |
|---------|-----------------|----------------------|---------------------|-------------|
| 0 | 2402 | 0.72 | 0.5 | Pass |
| 19 | 2440 | 0.72 | 0.5 | Pass |
| 39 | 2480 | 0.72 | 0.5 | Pass |

BT-LE 2M

| Channel | Frequency (MHz) | 6 dB Bandwidth (MHz) | Minimum Limit (MHz) | Test Result |
|---------|-----------------|----------------------|---------------------|-------------|
| 0 | 2402 | 1.25 | 0.5 | Pass |
| 19 | 2440 | 1.25 | 0.5 | Pass |
| 39 | 2480 | 1.25 | 0.5 | Pass |

Spectrum Plot of Minimum Value

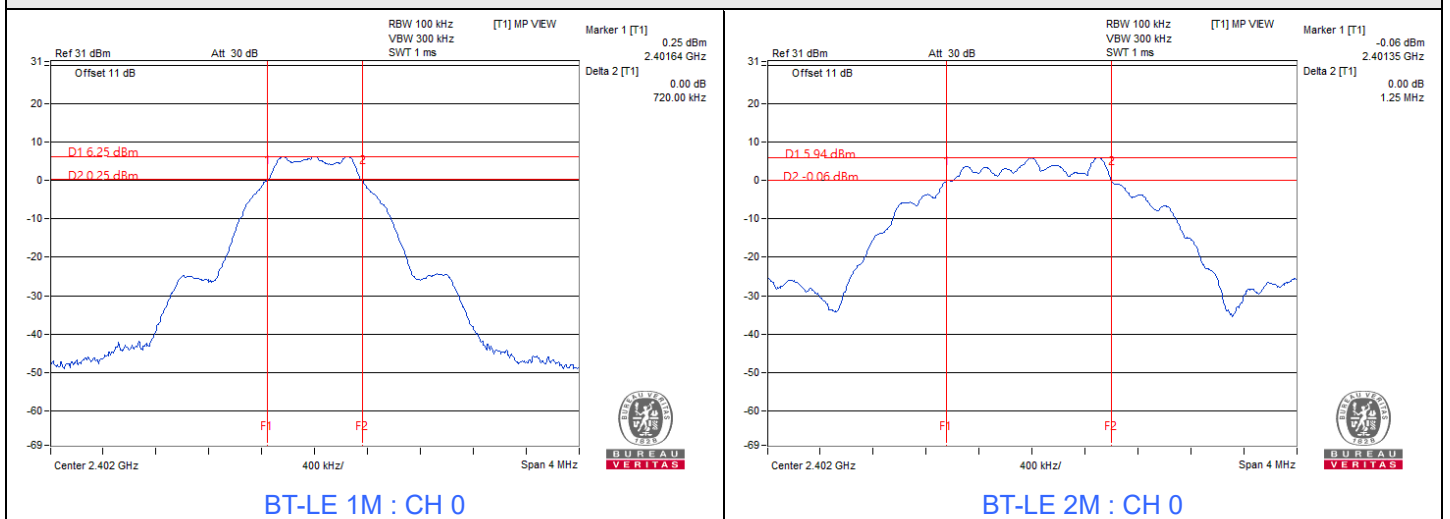

| | | | | | |
|--------------|----------------|---------------------------|--------------|------------|-----------|
| Input Power: | 120 Vac, 60 Hz | Environmental Conditions: | 25°C, 76% RH | Tested By: | Dalen Dai |
|--------------|----------------|---------------------------|--------------|------------|-----------|

A(Right Earphone)

BT-LE 1M

| Channel | Frequency (MHz) | 6 dB Bandwidth (MHz) | Minimum Limit (MHz) | Test Result |
|---------|-----------------|----------------------|---------------------|-------------|
| 0 | 2402 | 0.72 | 0.5 | Pass |
| 19 | 2440 | 0.72 | 0.5 | Pass |
| 39 | 2480 | 0.72 | 0.5 | Pass |

BT-LE 2M

| Channel | Frequency (MHz) | 6 dB Bandwidth (MHz) | Minimum Limit (MHz) | Test Result |
|---------|-----------------|----------------------|---------------------|-------------|
| 0 | 2402 | 1.25 | 0.5 | Pass |
| 19 | 2440 | 1.25 | 0.5 | Pass |
| 39 | 2480 | 1.25 | 0.5 | Pass |

Spectrum Plot of Minimum Value

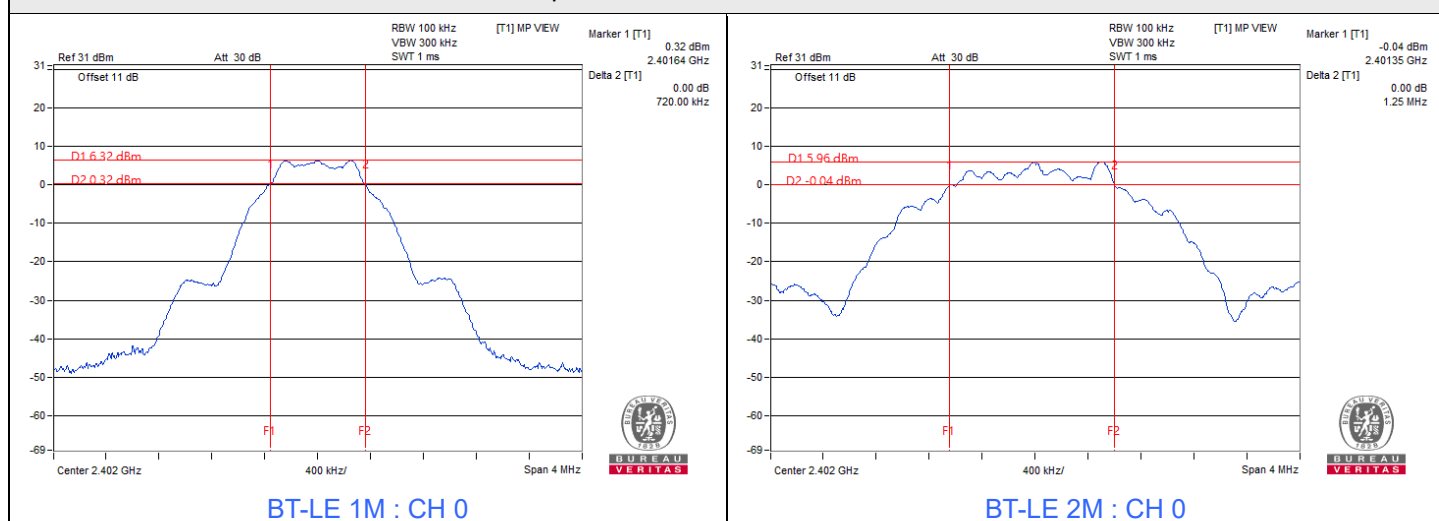



7.4 Conducted Out of Band Emissions

| | | | | | |
|--------------|----------------|---------------------------|--------------|------------|-----------|
| Input Power: | 120 Vac, 60 Hz | Environmental Conditions: | 25°C, 76% RH | Tested By: | Dalen Dai |
|--------------|----------------|---------------------------|--------------|------------|-----------|

A(Left Earphone)

BT-LE 1M

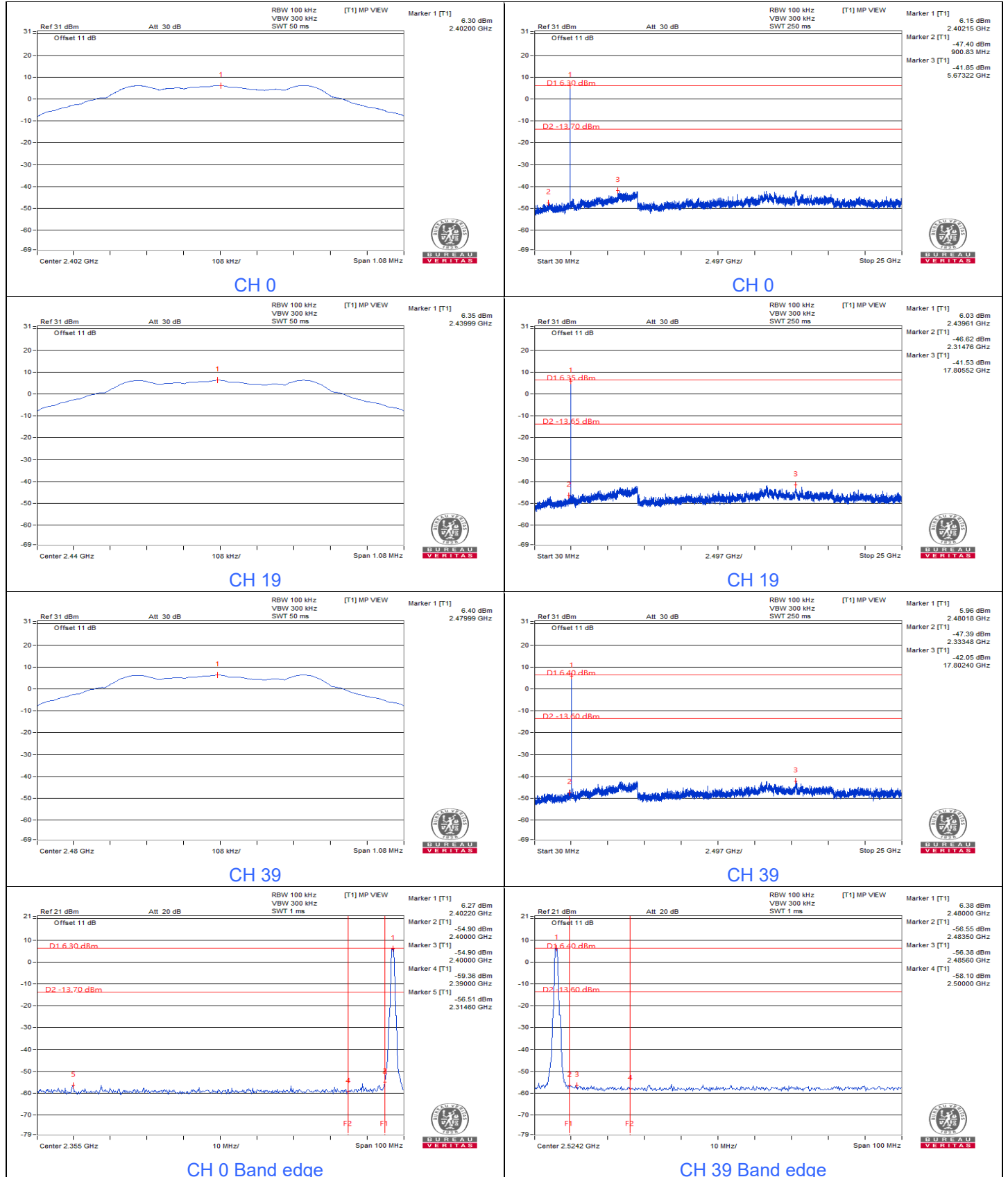



BT-LE 2M

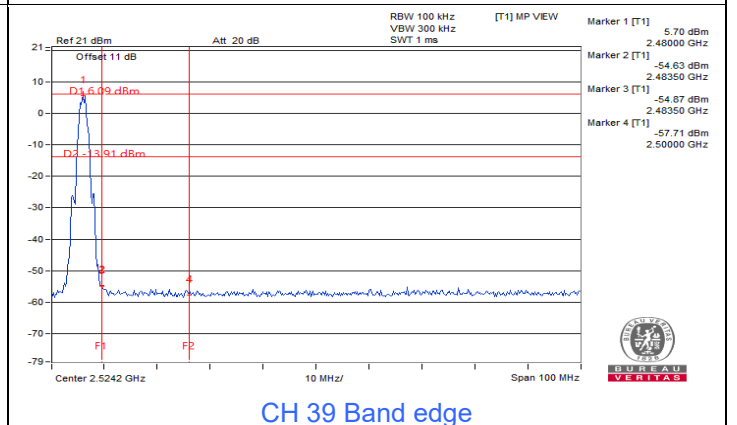
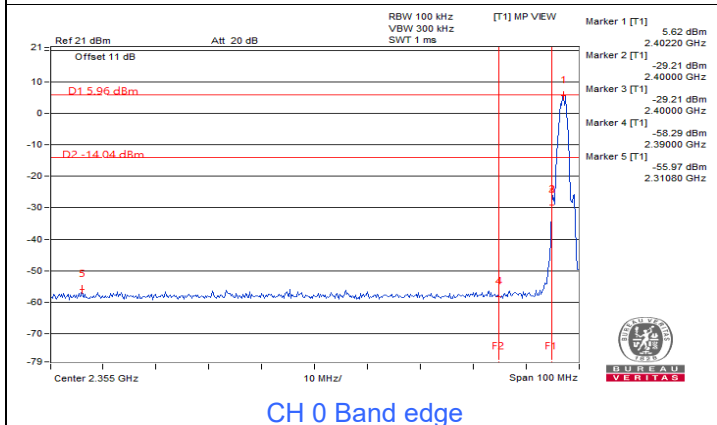
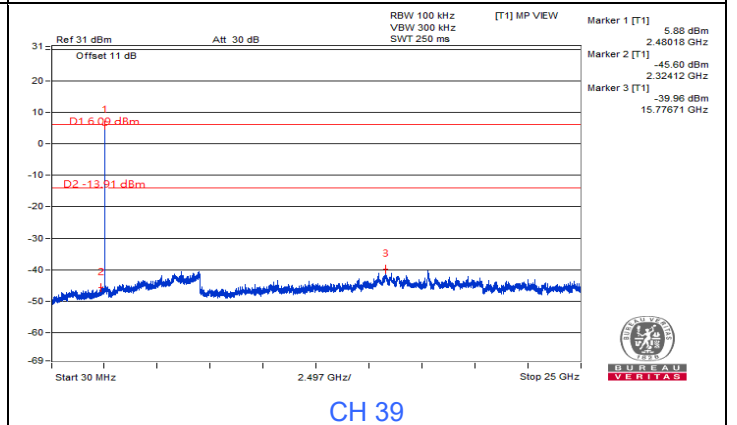
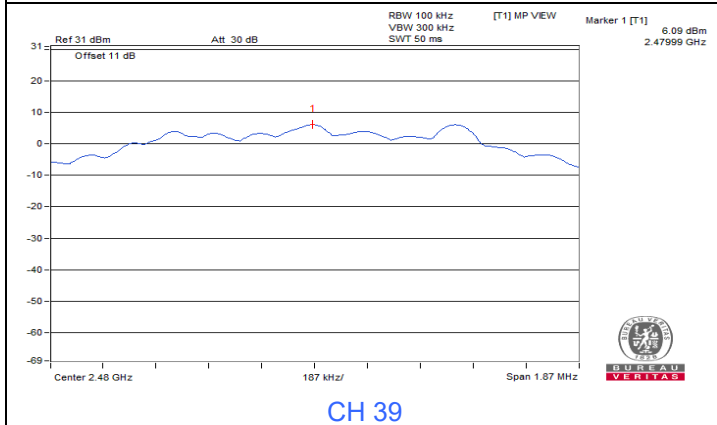
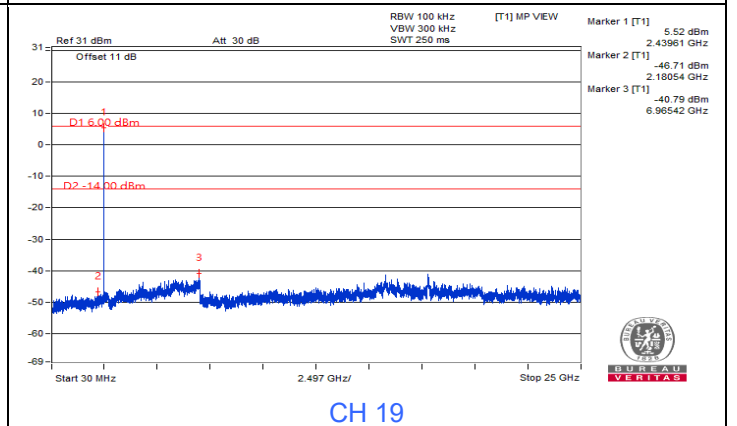
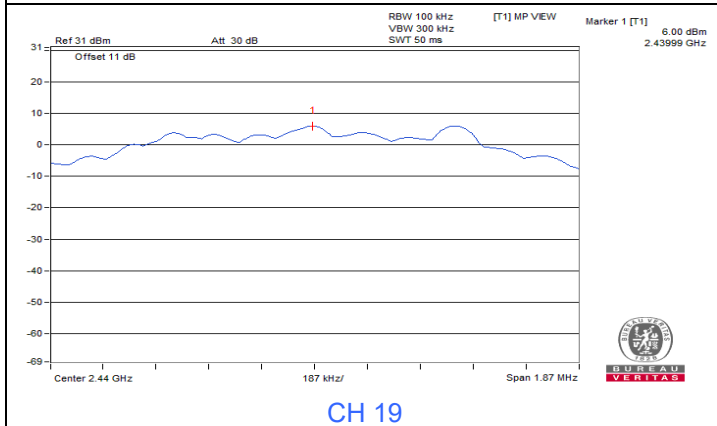
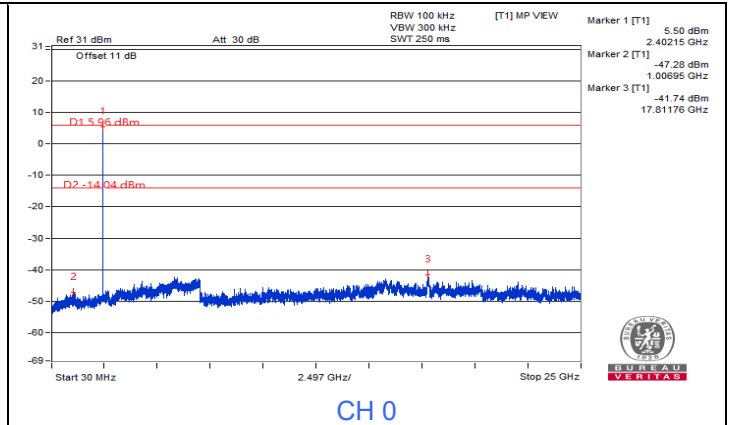
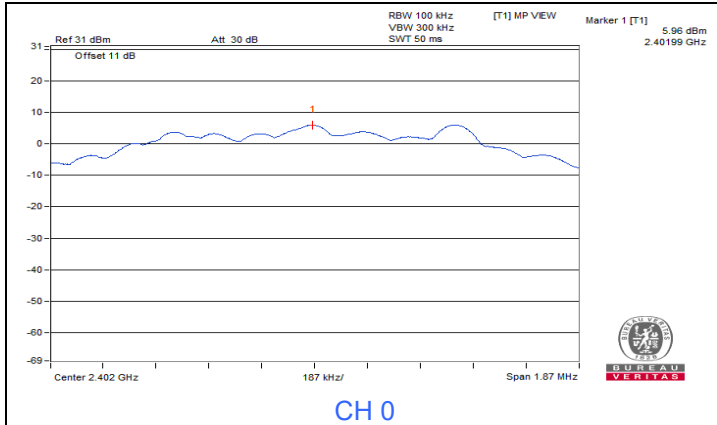

| | | | | | |
|--------------|----------------|---------------------------|--------------|------------|-----------|
| Input Power: | 120 Vac, 60 Hz | Environmental Conditions: | 25°C, 76% RH | Tested By: | Dalen Dai |
|--------------|----------------|---------------------------|--------------|------------|-----------|

A(Right Earphone)

BT-LE 1M

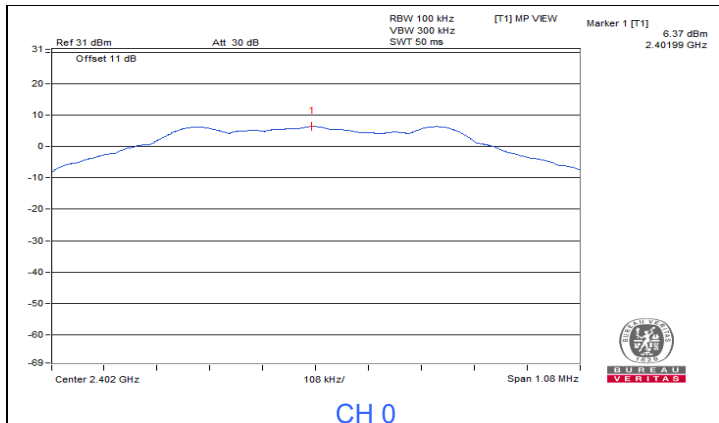

CH 0

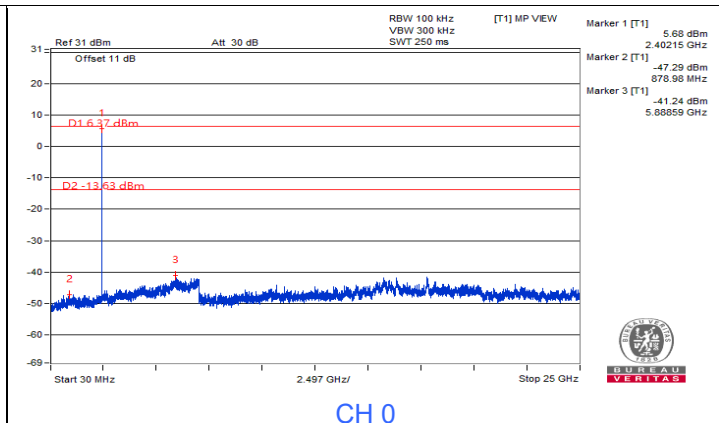

CH 0

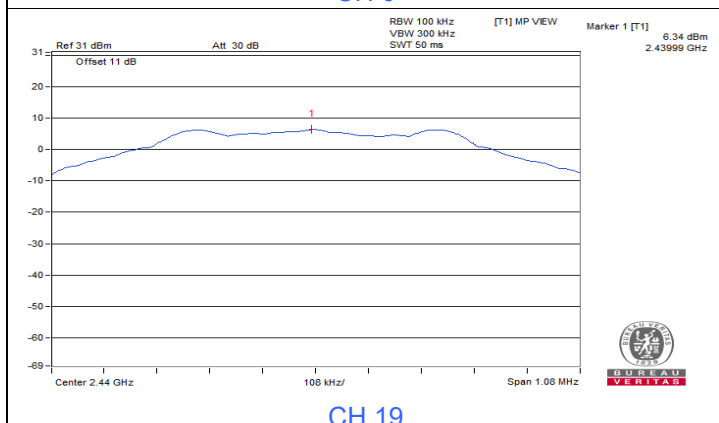

CH 19

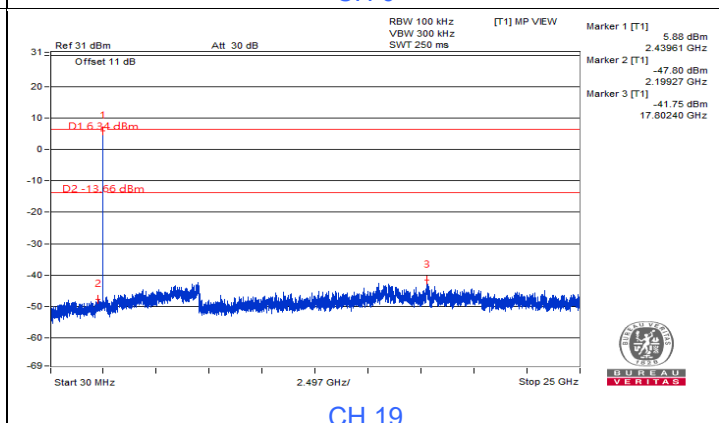

CH 19

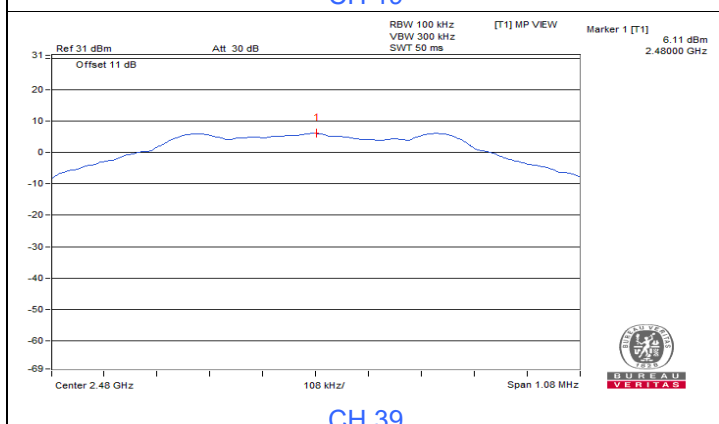

CH 39

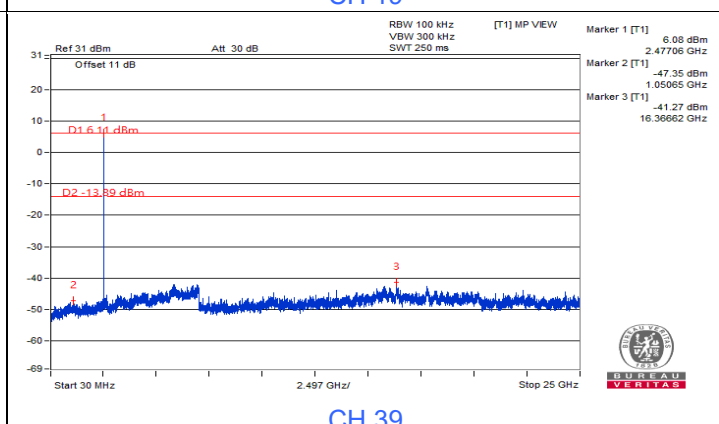

CH 39

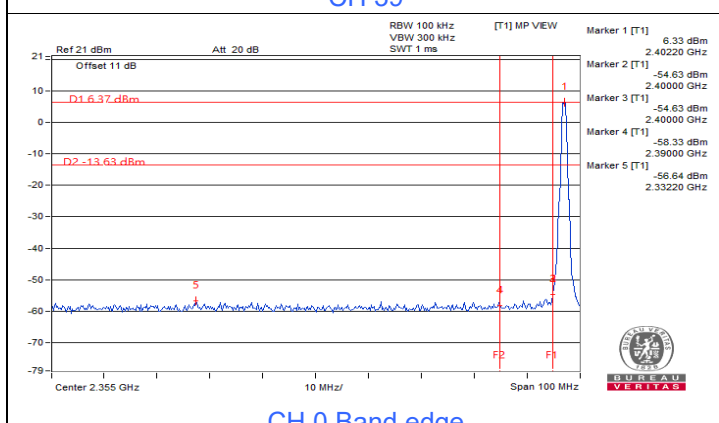

CH 0 Band edge

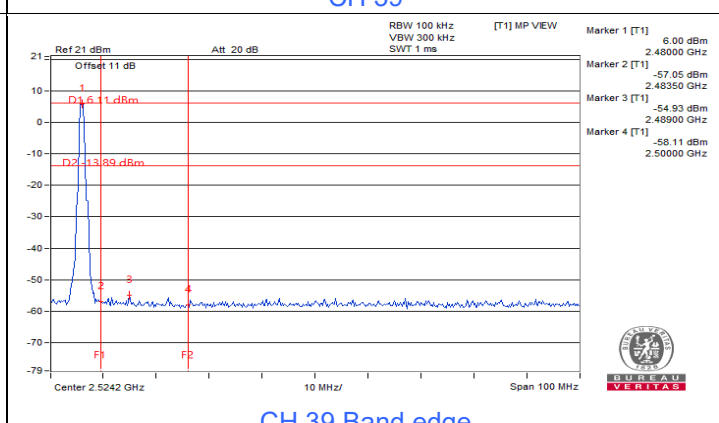

CH 39 Band edge



BT-LE 2M

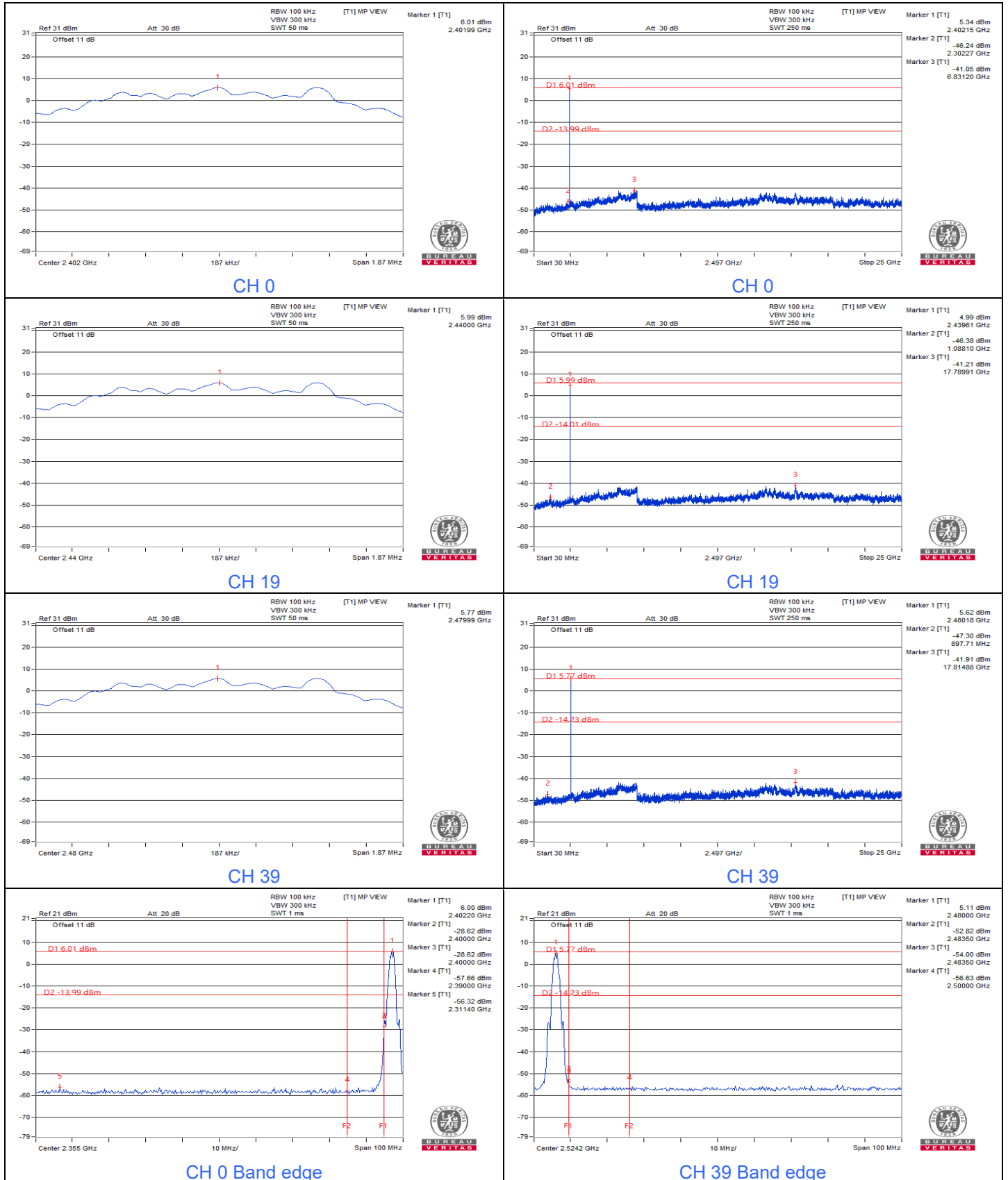

7.5 AC Power Conducted Emissions

A(Left Earphone)

| | | | |
|------------------------|------------------|---|---------------------------------------|
| RF Mode | BT-LE 1M | Channel | CH 39 : 2480 MHz |
| Frequency Range | 150 kHz ~ 30 MHz | Detector Function & Resolution Bandwidth | Quasi-Peak (QP) / Average (AV), 9 kHz |
| Input Power | 120 Vac, 60 Hz | Environmental Conditions | 25°C, 75% RH |
| Tested By | Jed Wu | | |

| Phase Of Power : Line (L) | | | | | | | | | | |
|---------------------------|-----------------|------------------------|----------------------|-------|-----------------------|-------|--------------|-------|-------------|--------|
| No | Frequency (MHz) | Correction Factor (dB) | Reading Value (dBuV) | | Emission Level (dBuV) | | Limit (dBuV) | | Margin (dB) | |
| | | | Q.P. | AV. | Q.P. | AV. | Q.P. | AV. | Q.P. | AV. |
| 1 | 0.15391 | 9.98 | 37.69 | 21.61 | 47.67 | 31.59 | 65.79 | 55.79 | -18.12 | -24.20 |
| 2 | 0.21622 | 10.05 | 28.89 | 16.80 | 38.94 | 26.85 | 62.96 | 52.96 | -24.02 | -26.11 |
| 3 | 0.54302 | 10.12 | 29.96 | 23.13 | 40.08 | 33.25 | 56.00 | 46.00 | -15.92 | -12.75 |
| 4 | 0.99279 | 10.07 | 17.46 | 10.73 | 27.53 | 20.80 | 56.00 | 46.00 | -28.47 | -25.20 |
| 5 | 3.60742 | 10.31 | 19.93 | 8.74 | 30.24 | 19.05 | 56.00 | 46.00 | -25.76 | -26.95 |
| 6 | 7.98018 | 10.81 | 14.25 | 7.83 | 25.06 | 18.64 | 60.00 | 50.00 | -34.94 | -31.36 |

Remarks:

1. Q.P. and AV. are abbreviations of quasi-peak and average individually.
2. The emission levels of other frequencies were very low against the limit.
3. Margin value = Emission level – Limit value
4. Correction factor = Insertion loss + Cable loss
5. Emission Level = Correction Factor + Reading Value

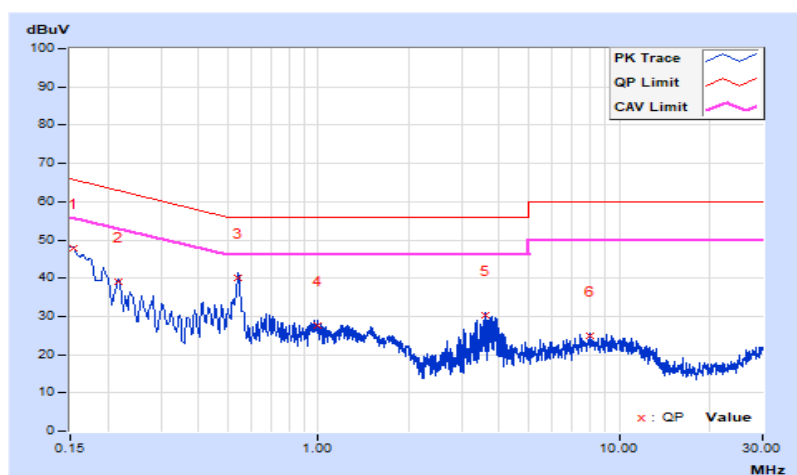

| | | | |
|------------------------|------------------|---|---------------------------------------|
| RF Mode | BT-LE 1M | Channel | CH 39 : 2480 MHz |
| Frequency Range | 150 kHz ~ 30 MHz | Detector Function & Resolution Bandwidth | Quasi-Peak (QP) / Average (AV), 9 kHz |
| Input Power | 120 Vac, 60 Hz | Environmental Conditions | 25°C, 75% RH |
| Tested By | Jed Wu | | |

| Phase Of Power : Neutral (N) | | | | | | | | | | |
|------------------------------|-----------------|------------------------|----------------------|-------|-----------------------|-------|--------------|-------|-------------|--------|
| No | Frequency (MHz) | Correction Factor (dB) | Reading Value (dBuV) | | Emission Level (dBuV) | | Limit (dBuV) | | Margin (dB) | |
| | | | Q.P. | AV. | Q.P. | AV. | Q.P. | AV. | Q.P. | AV. |
| 1 | 0.15391 | 10.26 | 37.88 | 17.03 | 48.14 | 27.29 | 65.79 | 55.79 | -17.65 | -28.50 |
| 2 | 0.23604 | 10.27 | 28.32 | 12.69 | 38.59 | 22.96 | 62.23 | 52.23 | -23.64 | -29.27 |
| 3 | 0.54520 | 10.31 | 29.90 | 23.51 | 40.21 | 33.82 | 56.00 | 46.00 | -15.79 | -12.18 |
| 4 | 1.12576 | 10.34 | 13.55 | 7.49 | 23.89 | 17.83 | 56.00 | 46.00 | -32.11 | -28.17 |
| 5 | 3.74039 | 10.57 | 19.99 | 8.52 | 30.56 | 19.09 | 56.00 | 46.00 | -25.44 | -26.91 |
| 6 | 9.60325 | 11.17 | 15.50 | 8.52 | 26.67 | 19.69 | 60.00 | 50.00 | -33.33 | -30.31 |

Remarks:

1. Q.P. and AV. are abbreviations of quasi-peak and average individually.
2. The emission levels of other frequencies were very low against the limit.
3. Margin value = Emission level – Limit value
4. Correction factor = Insertion loss + Cable loss
5. Emission Level = Correction Factor + Reading Value

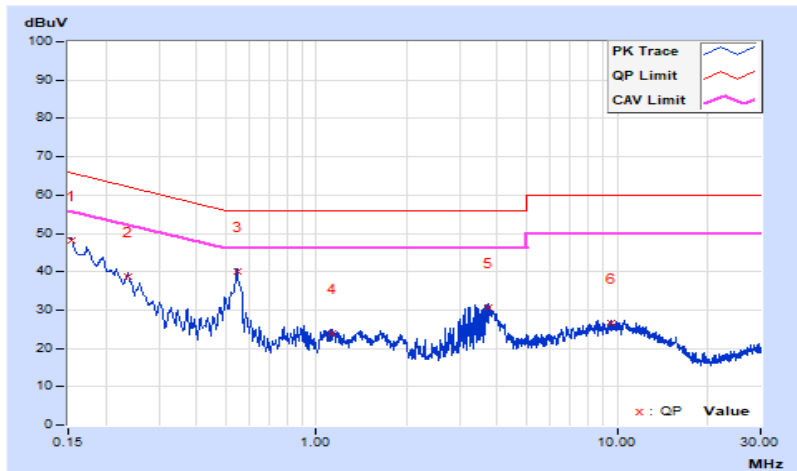

A(Right Earphone)

| | | | |
|-----------------|------------------|--|---------------------------------------|
| RF Mode | BT-LE 1M | Channel | CH 0 : 2402 MHz |
| Frequency Range | 150 kHz ~ 30 MHz | Detector Function & Resolution Bandwidth | Quasi-Peak (QP) / Average (AV), 9 kHz |
| Input Power | 120 Vac, 60 Hz | Environmental Conditions | 25°C, 75% RH |
| Tested By | Jed Wu | | |

| Phase Of Power : Line (L) | | | | | | | | | | |
|---------------------------|-----------------|------------------------|----------------------|--------------|-----------------------|--------------|--------------|--------------|---------------|---------------|
| No | Frequency (MHz) | Correction Factor (dB) | Reading Value (dBuV) | | Emission Level (dBuV) | | Limit (dBuV) | | Margin (dB) | |
| | | | Q.P. | AV. | Q.P. | AV. | Q.P. | AV. | Q.P. | AV. |
| 1 | 0.15391 | 9.98 | 38.84 | 22.70 | 48.82 | 32.68 | 65.79 | 55.79 | -16.97 | -23.11 |
| 2 | 0.26342 | 10.07 | 25.15 | 17.90 | 35.22 | 27.97 | 61.32 | 51.32 | -26.10 | -23.35 |
| 3 | 0.54302 | 10.12 | 30.95 | 24.14 | 41.07 | 34.26 | 56.00 | 46.00 | -14.93 | -11.74 |
| 4 | 0.99279 | 10.07 | 18.40 | 11.63 | 28.47 | 21.70 | 56.00 | 46.00 | -27.53 | -24.30 |
| 5 | 3.75162 | 10.33 | 18.79 | 8.50 | 29.12 | 18.83 | 56.00 | 46.00 | -26.88 | -27.17 |
| 6 | 7.47566 | 10.75 | 13.74 | 7.88 | 24.49 | 18.63 | 60.00 | 50.00 | -35.51 | -31.37 |

Remarks:

1. Q.P. and AV. are abbreviations of quasi-peak and average individually.
2. The emission levels of other frequencies were very low against the limit.
3. Margin value = Emission level – Limit value
4. Correction factor = Insertion loss + Cable loss
5. Emission Level = Correction Factor + Reading Value

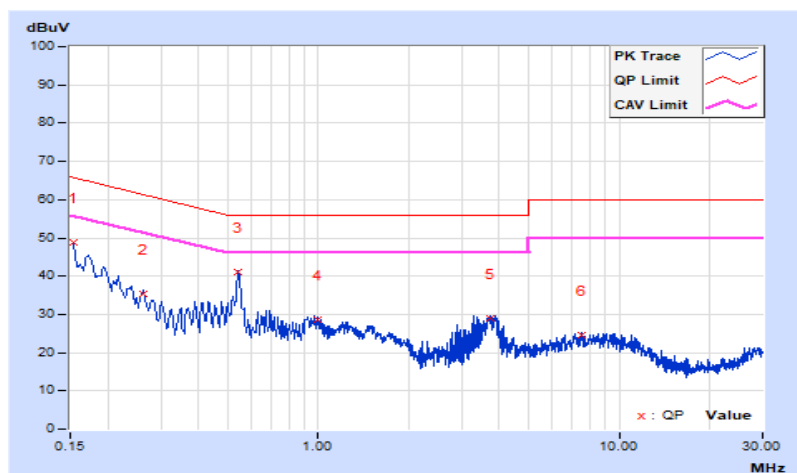

| | | | |
|-----------------|------------------|--|---------------------------------------|
| RF Mode | BT-LE 1M | Channel | CH 0 : 2402 MHz |
| Frequency Range | 150 kHz ~ 30 MHz | Detector Function & Resolution Bandwidth | Quasi-Peak (QP) / Average (AV), 9 kHz |
| Input Power | 120 Vac, 60 Hz | Environmental Conditions | 25°C, 75% RH |
| Tested By | Jed Wu | | |

| Phase Of Power : Neutral (N) | | | | | | | | | | |
|------------------------------|-----------------|------------------------|----------------------|-------|-----------------------|-------|--------------|-------|-------------|--------|
| No | Frequency (MHz) | Correction Factor (dB) | Reading Value (dBuV) | | Emission Level (dBuV) | | Limit (dBuV) | | Margin (dB) | |
| | | | Q.P. | AV. | Q.P. | AV. | Q.P. | AV. | Q.P. | AV. |
| 1 | 0.15391 | 10.26 | 37.90 | 16.92 | 48.16 | 27.18 | 65.79 | 55.79 | -17.63 | -28.61 |
| 2 | 0.21649 | 10.26 | 30.10 | 13.87 | 40.36 | 24.13 | 62.95 | 52.95 | -22.59 | -28.82 |
| 3 | 0.54664 | 10.31 | 29.66 | 23.00 | 39.97 | 33.31 | 56.00 | 46.00 | -16.03 | -12.69 |
| 4 | 1.38389 | 10.36 | 12.83 | 6.29 | 23.19 | 16.65 | 56.00 | 46.00 | -32.81 | -29.35 |
| 5 | 3.86164 | 10.58 | 20.03 | 9.16 | 30.61 | 19.74 | 56.00 | 46.00 | -25.39 | -26.26 |
| 6 | 10.67095 | 11.28 | 14.42 | 7.88 | 25.70 | 19.16 | 60.00 | 50.00 | -34.30 | -30.84 |

Remarks:

1. Q.P. and AV. are abbreviations of quasi-peak and average individually.
2. The emission levels of other frequencies were very low against the limit.
3. Margin value = Emission level – Limit value
4. Correction factor = Insertion loss + Cable loss
5. Emission Level = Correction Factor + Reading Value

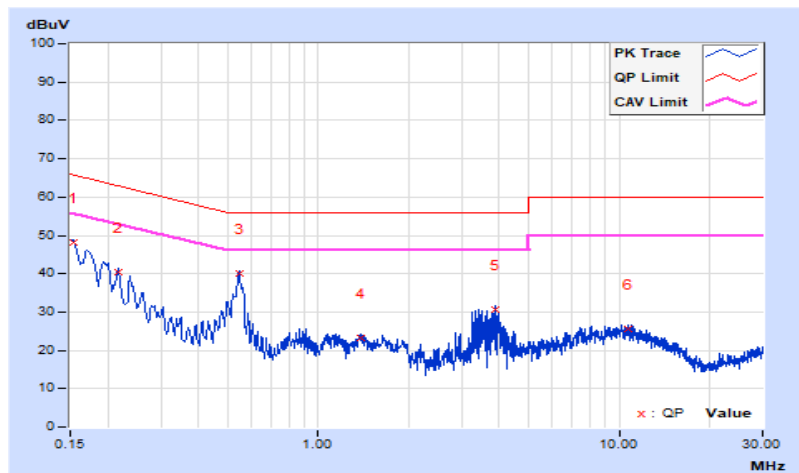

B(Left Earphone)

| | | | |
|-----------------|------------------|--|---------------------------------------|
| RF Mode | BT-LE 1M | Channel | CH 39 : 2480 MHz |
| Frequency Range | 150 kHz ~ 30 MHz | Detector Function & Resolution Bandwidth | Quasi-Peak (QP) / Average (AV), 9 kHz |
| Input Power | 120 Vac, 60 Hz | Environmental Conditions | 25°C, 75% RH |
| Tested By | Jed Wu | | |

Phase Of Power : Line (L)

| No | Frequency (MHz) | Correction Factor (dB) | Reading Value (dBuV) | | Emission Level (dBuV) | | Limit (dBuV) | | Margin (dB) | |
|----|-----------------|------------------------|----------------------|-------|-----------------------|-------|--------------|-------|-------------|--------|
| | | | Q.P. | AV. | Q.P. | AV. | Q.P. | AV. | Q.P. | AV. |
| 1 | 0.15391 | 9.98 | 26.35 | 10.29 | 36.33 | 20.27 | 65.79 | 55.79 | -29.46 | -35.52 |
| 2 | 0.47852 | 10.12 | 19.24 | 6.23 | 29.36 | 16.35 | 56.36 | 46.36 | -27.00 | -30.01 |
| 3 | 0.69111 | 10.10 | 26.74 | 8.05 | 36.84 | 18.15 | 56.00 | 46.00 | -19.16 | -27.85 |
| 4 | 1.13358 | 10.08 | 19.22 | 4.36 | 29.30 | 14.44 | 56.00 | 46.00 | -26.70 | -31.56 |
| 5 | 4.98409 | 10.46 | 17.90 | 5.73 | 28.36 | 16.19 | 56.00 | 46.00 | -27.64 | -29.81 |
| 6 | 25.52102 | 12.91 | 6.09 | 4.70 | 19.00 | 17.61 | 60.00 | 50.00 | -41.00 | -32.39 |

Remarks:

1. Q.P. and AV. are abbreviations of quasi-peak and average individually.
2. The emission levels of other frequencies were very low against the limit.
3. Margin value = Emission level – Limit value
4. Correction factor = Insertion loss + Cable loss
5. Emission Level = Correction Factor + Reading Value

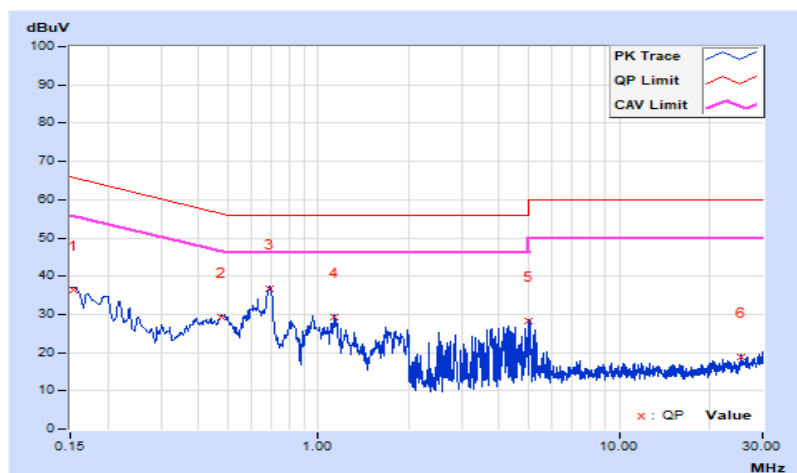

| | | | |
|-----------------|------------------|--|---------------------------------------|
| RF Mode | BT-LE 1M | Channel | CH 39 : 2480 MHz |
| Frequency Range | 150 kHz ~ 30 MHz | Detector Function & Resolution Bandwidth | Quasi-Peak (QP) / Average (AV), 9 kHz |
| Input Power | 120 Vac, 60 Hz | Environmental Conditions | 25°C, 75% RH |
| Tested By | Jed Wu | | |

| Phase Of Power : Neutral (N) | | | | | | | | | | |
|------------------------------|-----------------|------------------------|----------------------|-------|-----------------------|-------|--------------|-------|-------------|--------|
| No | Frequency (MHz) | Correction Factor (dB) | Reading Value (dBuV) | | Emission Level (dBuV) | | Limit (dBuV) | | Margin (dB) | |
| | | | Q.P. | AV. | Q.P. | AV. | Q.P. | AV. | Q.P. | AV. |
| 1 | 0.15000 | 10.26 | 25.76 | 9.25 | 36.02 | 19.51 | 66.00 | 56.00 | -29.98 | -36.49 |
| 2 | 0.25560 | 10.27 | 21.96 | 13.15 | 32.23 | 23.42 | 61.57 | 51.57 | -29.34 | -28.15 |
| 3 | 0.67600 | 10.31 | 22.16 | 7.60 | 32.47 | 17.91 | 56.00 | 46.00 | -23.53 | -28.09 |
| 4 | 1.13718 | 10.34 | 15.05 | 3.73 | 25.39 | 14.07 | 56.00 | 46.00 | -30.61 | -31.93 |
| 5 | 4.15105 | 10.61 | 15.75 | 6.81 | 26.36 | 17.42 | 56.00 | 46.00 | -29.64 | -28.58 |
| 6 | 5.03129 | 10.70 | 14.97 | 5.17 | 25.67 | 15.87 | 60.00 | 50.00 | -34.33 | -34.13 |

Remarks:

1. Q.P. and AV. are abbreviations of quasi-peak and average individually.
2. The emission levels of other frequencies were very low against the limit.
3. Margin value = Emission level – Limit value
4. Correction factor = Insertion loss + Cable loss
5. Emission Level = Correction Factor + Reading Value

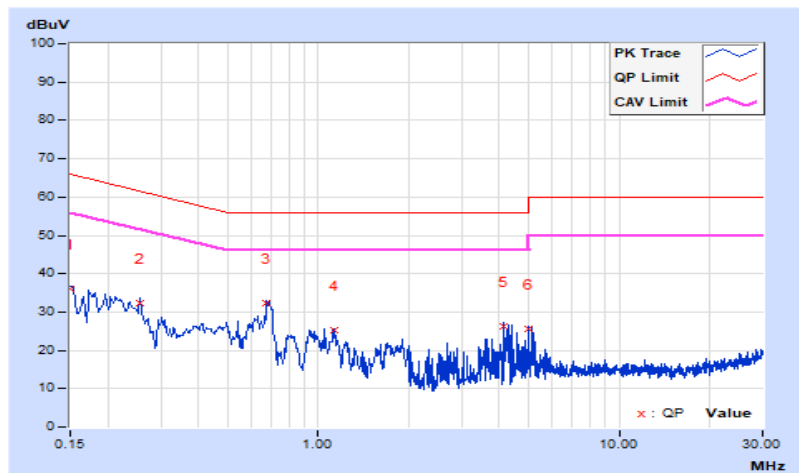

B(Right Earphone)

| | | | |
|-----------------|------------------|--|---------------------------------------|
| RF Mode | BT-LE 1M | Channel | CH 0 : 2402 MHz |
| Frequency Range | 150 kHz ~ 30 MHz | Detector Function & Resolution Bandwidth | Quasi-Peak (QP) / Average (AV), 9 kHz |
| Input Power | 120 Vac, 60 Hz | Environmental Conditions | 25°C, 75% RH |
| Tested By | Jed Wu | | |

Phase Of Power : Line (L)

| No | Frequency (MHz) | Correction Factor (dB) | Reading Value (dBuV) | | Emission Level (dBuV) | | Limit (dBuV) | | Margin (dB) | |
|----|-----------------|------------------------|----------------------|-------|-----------------------|-------|--------------|-------|-------------|--------|
| | | | Q.P. | AV. | Q.P. | AV. | Q.P. | AV. | Q.P. | AV. |
| 1 | 0.15000 | 9.97 | 28.88 | 11.81 | 38.85 | 21.78 | 66.00 | 56.00 | -27.15 | -34.22 |
| 2 | 0.25560 | 10.07 | 22.29 | 13.67 | 32.36 | 23.74 | 61.57 | 51.57 | -29.21 | -27.83 |
| 3 | 0.68382 | 10.10 | 26.52 | 7.12 | 36.62 | 17.22 | 56.00 | 46.00 | -19.38 | -28.78 |
| 4 | 1.13749 | 10.08 | 19.66 | 4.62 | 29.74 | 14.70 | 56.00 | 46.00 | -26.26 | -31.30 |
| 5 | 4.37007 | 10.39 | 18.30 | 3.49 | 28.69 | 13.88 | 56.00 | 46.00 | -27.31 | -32.12 |
| 6 | 5.07040 | 10.47 | 16.88 | 4.75 | 27.35 | 15.22 | 60.00 | 50.00 | -32.65 | -34.78 |

Remarks:

1. Q.P. and AV. are abbreviations of quasi-peak and average individually.
2. The emission levels of other frequencies were very low against the limit.
3. Margin value = Emission level – Limit value
4. Correction factor = Insertion loss + Cable loss
5. Emission Level = Correction Factor + Reading Value

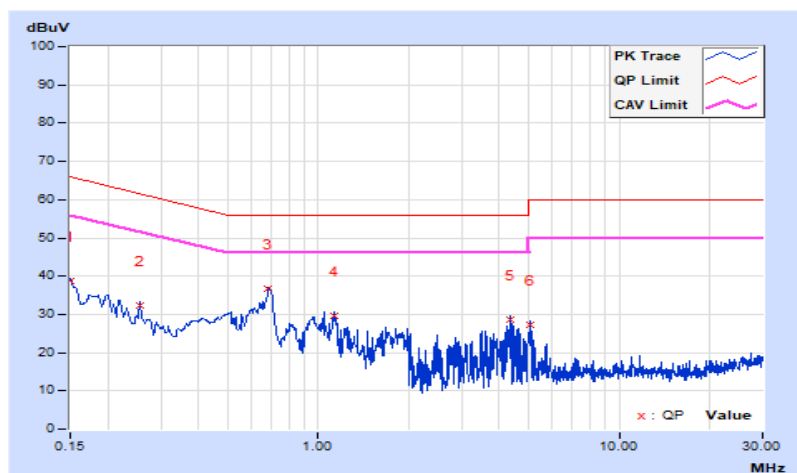

| | | | |
|-----------------|------------------|--|---------------------------------------|
| RF Mode | BT-LE 1M | Channel | CH 0 : 2402 MHz |
| Frequency Range | 150 kHz ~ 30 MHz | Detector Function & Resolution Bandwidth | Quasi-Peak (QP) / Average (AV), 9 kHz |
| Input Power | 120 Vac, 60 Hz | Environmental Conditions | 25°C, 75% RH |
| Tested By | Jed Wu | | |

| Phase Of Power : Neutral (N) | | | | | | | | | | |
|------------------------------|-----------------|------------------------|----------------------|-------|-----------------------|-------|--------------|-------|-------------|--------|
| No | Frequency (MHz) | Correction Factor (dB) | Reading Value (dBuV) | | Emission Level (dBuV) | | Limit (dBuV) | | Margin (dB) | |
| | | | Q.P. | AV. | Q.P. | AV. | Q.P. | AV. | Q.P. | AV. |
| 1 | 0.15719 | 10.26 | 26.05 | 8.73 | 36.31 | 18.99 | 65.61 | 55.61 | -29.30 | -36.62 |
| 2 | 0.24777 | 10.27 | 19.66 | 11.41 | 29.93 | 21.68 | 61.83 | 51.83 | -31.90 | -30.15 |
| 3 | 0.69476 | 10.31 | 22.91 | 8.65 | 33.22 | 18.96 | 56.00 | 46.00 | -22.78 | -27.04 |
| 4 | 1.99400 | 10.42 | 11.13 | 3.47 | 21.55 | 13.89 | 56.00 | 46.00 | -34.45 | -32.11 |
| 5 | 4.30358 | 10.62 | 16.12 | 3.60 | 26.74 | 14.22 | 56.00 | 46.00 | -29.26 | -31.78 |
| 6 | 5.11342 | 10.71 | 15.52 | 3.82 | 26.23 | 14.53 | 60.00 | 50.00 | -33.77 | -35.47 |

Remarks:

1. Q.P. and AV. are abbreviations of quasi-peak and average individually.
2. The emission levels of other frequencies were very low against the limit.
3. Margin value = Emission level – Limit value
4. Correction factor = Insertion loss + Cable loss
5. Emission Level = Correction Factor + Reading Value

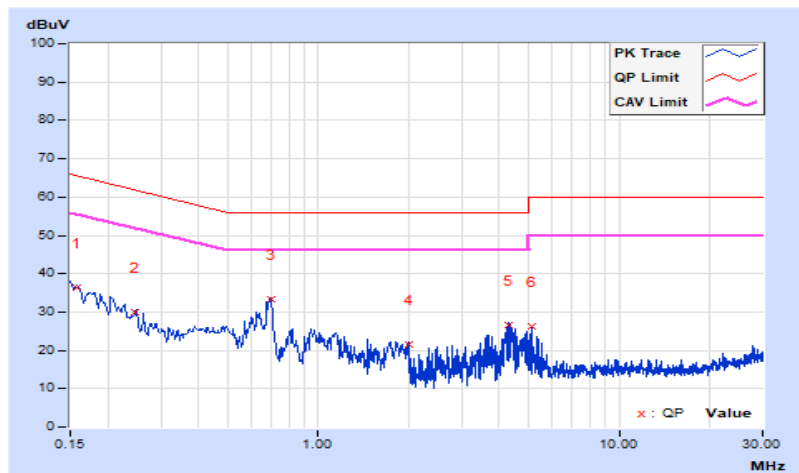

C(Left Earphone)

| | | | |
|-----------------|------------------|--|---------------------------------------|
| RF Mode | BT-LE 1M | Channel | CH 39 : 2480 MHz |
| Frequency Range | 150 kHz ~ 30 MHz | Detector Function & Resolution Bandwidth | Quasi-Peak (QP) / Average (AV), 9 kHz |
| Input Power | 120 Vac, 60 Hz | Environmental Conditions | 25°C, 75% RH |
| Tested By | Jed Wu | | |

Phase Of Power : Line (L)

| No | Frequency (MHz) | Correction Factor (dB) | Reading Value (dBuV) | | Emission Level (dBuV) | | Limit (dBuV) | | Margin (dB) | |
|----|-----------------|------------------------|----------------------|-------|-----------------------|-------|--------------|-------|-------------|--------|
| | | | Q.P. | AV. | Q.P. | AV. | Q.P. | AV. | Q.P. | AV. |
| 1 | 0.15719 | 9.98 | 29.69 | 11.90 | 39.67 | 21.88 | 65.61 | 55.61 | -25.94 | -33.73 |
| 2 | 0.40421 | 10.13 | 25.68 | 20.67 | 35.81 | 30.80 | 57.77 | 47.77 | -21.96 | -16.97 |
| 3 | 0.76591 | 10.09 | 18.80 | 14.68 | 28.89 | 24.77 | 56.00 | 46.00 | -27.11 | -21.23 |
| 4 | 1.78919 | 10.14 | 16.85 | 12.81 | 26.99 | 22.95 | 56.00 | 46.00 | -29.01 | -23.05 |
| 5 | 8.43386 | 10.86 | 9.29 | 4.80 | 20.15 | 15.66 | 60.00 | 50.00 | -39.85 | -34.34 |
| 6 | 29.25993 | 13.33 | 17.49 | 16.58 | 30.82 | 29.91 | 60.00 | 50.00 | -29.18 | -20.09 |

Remarks:

1. Q.P. and AV. are abbreviations of quasi-peak and average individually.
2. The emission levels of other frequencies were very low against the limit.
3. Margin value = Emission level – Limit value
4. Correction factor = Insertion loss + Cable loss
5. Emission Level = Correction Factor + Reading Value

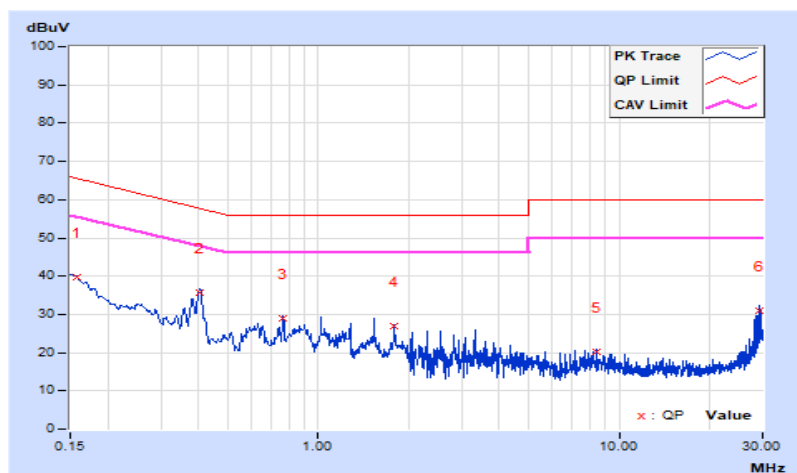

| | | | |
|------------------------|------------------|---|---------------------------------------|
| RF Mode | BT-LE 1M | Channel | CH 39 : 2480 MHz |
| Frequency Range | 150 kHz ~ 30 MHz | Detector Function & Resolution Bandwidth | Quasi-Peak (QP) / Average (AV), 9 kHz |
| Input Power | 120 Vac, 60 Hz | Environmental Conditions | 25°C, 75% RH |
| Tested By | Jed Wu | | |

| Phase Of Power : Neutral (N) | | | | | | | | | | |
|------------------------------|-----------------|------------------------|----------------------|-------|-----------------------|-------|--------------|-------|-------------|--------|
| No | Frequency (MHz) | Correction Factor (dB) | Reading Value (dBuV) | | Emission Level (dBuV) | | Limit (dBuV) | | Margin (dB) | |
| | | | Q.P. | AV. | Q.P. | AV. | Q.P. | AV. | Q.P. | AV. |
| 1 | 0.15782 | 10.26 | 30.65 | 16.06 | 40.91 | 26.32 | 65.58 | 55.58 | -24.67 | -29.26 |
| 2 | 0.40268 | 10.30 | 28.11 | 23.07 | 38.41 | 33.37 | 57.80 | 47.80 | -19.39 | -14.43 |
| 3 | 0.76591 | 10.32 | 17.82 | 14.16 | 28.14 | 24.48 | 56.00 | 46.00 | -27.86 | -21.52 |
| 4 | 1.53250 | 10.38 | 17.04 | 14.73 | 27.42 | 25.11 | 56.00 | 46.00 | -28.58 | -20.89 |
| 5 | 6.34538 | 10.83 | 13.61 | 7.26 | 24.44 | 18.09 | 60.00 | 50.00 | -35.56 | -31.91 |
| 6 | 29.25993 | 13.54 | 17.70 | 15.76 | 31.24 | 29.30 | 60.00 | 50.00 | -28.76 | -20.70 |

Remarks:

1. Q.P. and AV. are abbreviations of quasi-peak and average individually.
2. The emission levels of other frequencies were very low against the limit.
3. Margin value = Emission level – Limit value
4. Correction factor = Insertion loss + Cable loss
5. Emission Level = Correction Factor + Reading Value

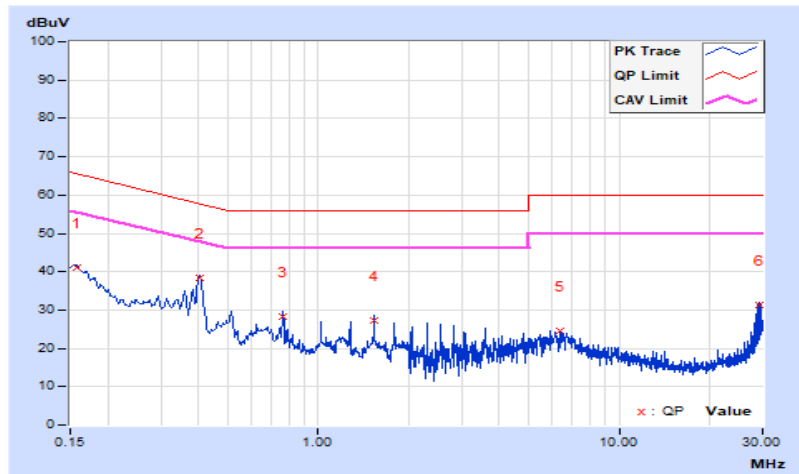

C(Right Earphone)

| | | | |
|-----------------|------------------|--|---------------------------------------|
| RF Mode | BT-LE 1M | Channel | CH 0 : 2402 MHz |
| Frequency Range | 150 kHz ~ 30 MHz | Detector Function & Resolution Bandwidth | Quasi-Peak (QP) / Average (AV), 9 kHz |
| Input Power | 120 Vac, 60 Hz | Environmental Conditions | 25°C, 75% RH |
| Tested By | Jed Wu | | |

Phase Of Power : Line (L)

| No | Frequency (MHz) | Correction Factor (dB) | Reading Value (dBuV) | | Emission Level (dBuV) | | Limit (dBuV) | | Margin (dB) | |
|----|-----------------|------------------------|----------------------|-------|-----------------------|-------|--------------|-------|-------------|--------|
| | | | Q.P. | AV. | Q.P. | AV. | Q.P. | AV. | Q.P. | AV. |
| 1 | 0.15760 | 9.98 | 29.93 | 11.12 | 39.91 | 21.10 | 65.59 | 55.59 | -25.68 | -34.49 |
| 2 | 0.40421 | 10.13 | 26.03 | 21.32 | 36.16 | 31.45 | 57.77 | 47.77 | -21.61 | -16.32 |
| 3 | 1.02407 | 10.07 | 18.73 | 15.51 | 28.80 | 25.58 | 56.00 | 46.00 | -27.20 | -20.42 |
| 4 | 1.53250 | 10.12 | 18.35 | 15.13 | 28.47 | 25.25 | 56.00 | 46.00 | -27.53 | -20.75 |
| 5 | 8.43386 | 10.86 | 10.63 | 9.02 | 21.49 | 19.88 | 60.00 | 50.00 | -38.51 | -30.12 |
| 6 | 29.00572 | 13.30 | 17.33 | 15.67 | 30.63 | 28.97 | 60.00 | 50.00 | -29.37 | -21.03 |

Remarks:

1. Q.P. and AV. are abbreviations of quasi-peak and average individually.
2. The emission levels of other frequencies were very low against the limit.
3. Margin value = Emission level – Limit value
4. Correction factor = Insertion loss + Cable loss
5. Emission Level = Correction Factor + Reading Value

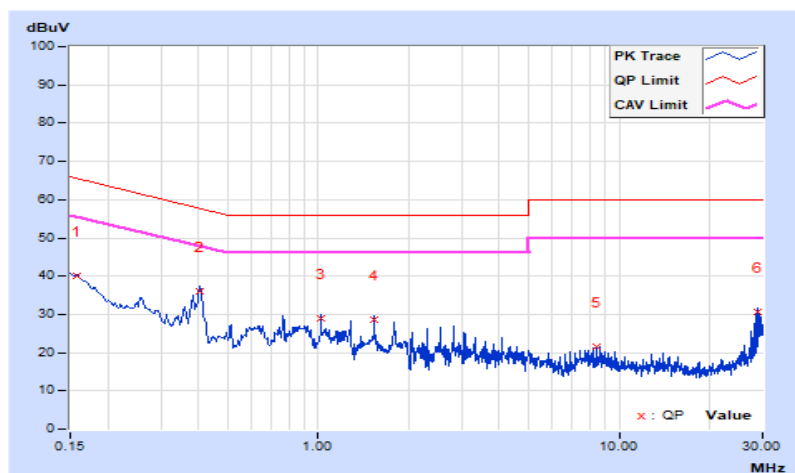

| | | | |
|-----------------|------------------|--|---------------------------------------|
| RF Mode | BT-LE 1M | Channel | CH 0 : 2402 MHz |
| Frequency Range | 150 kHz ~ 30 MHz | Detector Function & Resolution Bandwidth | Quasi-Peak (QP) / Average (AV), 9 kHz |
| Input Power | 120 Vac, 60 Hz | Environmental Conditions | 25°C, 75% RH |
| Tested By | Jed Wu | | |

| Phase Of Power : Neutral (N) | | | | | | | | | | |
|------------------------------|-----------------|------------------------|----------------------|-------|-----------------------|-------|--------------|-------|-------------|--------|
| No | Frequency (MHz) | Correction Factor (dB) | Reading Value (dBuV) | | Emission Level (dBuV) | | Limit (dBuV) | | Margin (dB) | |
| | | | Q.P. | AV. | Q.P. | AV. | Q.P. | AV. | Q.P. | AV. |
| 1 | 0.15000 | 10.26 | 32.11 | 17.19 | 42.37 | 27.45 | 66.00 | 56.00 | -23.63 | -28.55 |
| 2 | 0.40421 | 10.30 | 28.16 | 23.06 | 38.46 | 33.36 | 57.77 | 47.77 | -19.31 | -14.41 |
| 3 | 0.76591 | 10.32 | 17.94 | 14.21 | 28.26 | 24.53 | 56.00 | 46.00 | -27.74 | -21.47 |
| 4 | 1.53250 | 10.38 | 17.12 | 13.77 | 27.50 | 24.15 | 56.00 | 46.00 | -28.50 | -21.85 |
| 5 | 6.38817 | 10.84 | 12.95 | 8.12 | 23.79 | 18.96 | 60.00 | 50.00 | -36.21 | -31.04 |
| 6 | 29.51806 | 13.58 | 17.62 | 14.39 | 31.20 | 27.97 | 60.00 | 50.00 | -28.80 | -22.03 |

Remarks:

1. Q.P. and AV. are abbreviations of quasi-peak and average individually.
2. The emission levels of other frequencies were very low against the limit.
3. Margin value = Emission level – Limit value
4. Correction factor = Insertion loss + Cable loss
5. Emission Level = Correction Factor + Reading Value

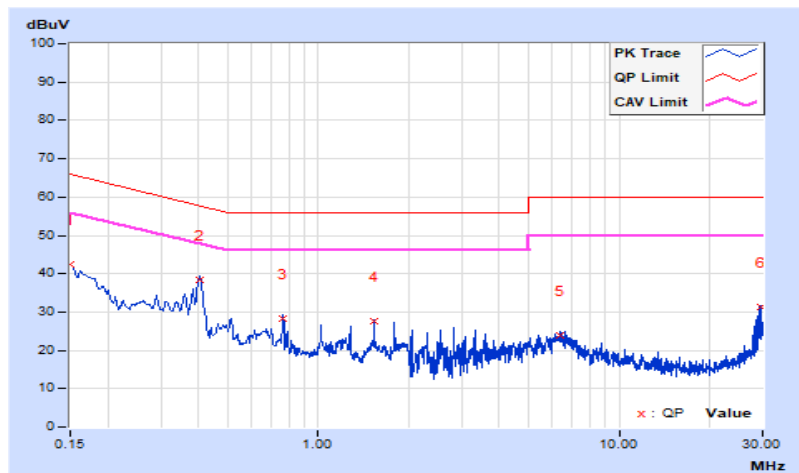

7.6 Unwanted Emissions below 1 GHz

A(Left Earphone)

| | | | |
|-----------------|----------------|-------------------------------|-------------------------------|
| RF Mode | BT-LE 1M | Channel | CH 39 : 2480 MHz |
| Frequency Range | 30 MHz ~ 1 GHz | Detector Function & Bandwidth | QP: RB=120kHz, DET=Quasi-Peak |
| Input Power | 120 Vac, 60 Hz | Environmental Conditions | 25°C, 75% RH |
| Tested By | William Su | | |

| Antenna Polarity & Test Distance : Horizontal at 3 m | | | | | | | | |
|--|-----------------|-------------------------|----------------|-------------|--------------------|----------------------|------------------|--------------------------|
| No | Frequency (MHz) | Emission Level (dBuV/m) | Limit (dBuV/m) | Margin (dB) | Antenna Height (m) | Table Angle (Degree) | Raw Value (dBuV) | Correction Factor (dB/m) |
| 1 | 71.61 | 20.4 QP | 40.0 | -19.6 | 1.27 H | 307 | 31.7 | -11.3 |
| 2 | 133.21 | 19.1 QP | 43.5 | -24.4 | 1.39 H | 262 | 28.6 | -9.5 |
| 3 | 280.36 | 20.2 QP | 46.0 | -25.8 | 1.46 H | 130 | 27.1 | -6.9 |
| 4 | 363.53 | 22.7 QP | 46.0 | -23.3 | 1.15 H | 142 | 27.7 | -5.0 |
| 5 | 437.06 | 24.7 QP | 46.0 | -21.3 | 1.83 H | 348 | 27.8 | -3.1 |
| 6 | 507.05 | 26.4 QP | 46.0 | -19.6 | 1.00 H | 15 | 28.2 | -1.8 |

Remarks:

1. Emission Level(dBuV/m) = Raw Value(dBuV) + Correction Factor(dB/m)
2. Correction Factor(dB/m) = Antenna Factor(dB/m) + Cable Factor(dB) – Pre-Amplifier Factor(dB)
3. Margin value = Emission Level – Limit value
4. The other emission levels were very low against the limit of frequency range 30 MHz ~ 1 GHz.
5. The frequency range 9 kHz ~ 30 MHz: all emissions are more than 20 dB below the limit, therefore do not be recorded in this report.

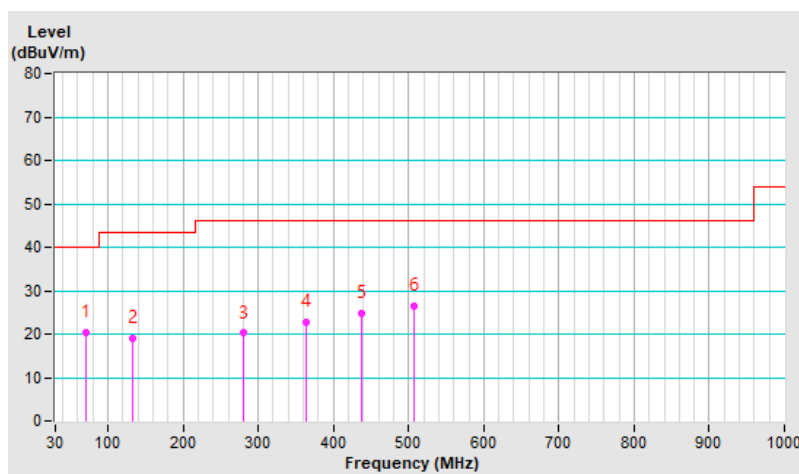

| | | | |
|------------------------|----------------|--|-------------------------------|
| RF Mode | BT-LE 1M | Channel | CH 39 : 2480 MHz |
| Frequency Range | 30 MHz ~ 1 GHz | Detector Function & Bandwidth | QP: RB=120kHz, DET=Quasi-Peak |
| Input Power | 120 Vac, 60 Hz | Environmental Conditions | 25°C, 75% RH |
| Tested By | William Su | | |

| Antenna Polarity & Test Distance : Vertical at 3 m | | | | | | | | |
|--|-----------------|-------------------------|----------------|-------------|--------------------|----------------------|------------------|--------------------------|
| No | Frequency (MHz) | Emission Level (dBuV/m) | Limit (dBuV/m) | Margin (dB) | Antenna Height (m) | Table Angle (Degree) | Raw Value (dBuV) | Correction Factor (dB/m) |
| 1 | 71.56 | 20.2 QP | 40.0 | -19.8 | 1.42 V | 198 | 31.5 | -11.3 |
| 2 | 168.61 | 19.3 QP | 43.5 | -24.2 | 1.58 V | 174 | 27.9 | -8.6 |
| 3 | 324.59 | 21.9 QP | 46.0 | -24.1 | 1.73 V | 264 | 27.5 | -5.6 |
| 4 | 381.77 | 24.1 QP | 46.0 | -21.9 | 1.64 V | 338 | 28.7 | -4.6 |
| 5 | 486.58 | 25.4 QP | 46.0 | -20.6 | 1.85 V | 281 | 27.6 | -2.2 |
| 6 | 591.48 | 27.9 QP | 46.0 | -18.1 | 1.00 V | 283 | 27.7 | 0.2 |

Remarks:

1. Emission Level(dBuV/m) = Raw Value(dBuV) + Correction Factor(dB/m)
2. Correction Factor(dB/m) = Antenna Factor(dB/m) + Cable Factor(dB) – Pre-Amplifier Factor(dB)
3. Margin value = Emission Level – Limit value
4. The other emission levels were very low against the limit of frequency range 30 MHz ~ 1 GHz.
5. The frequency range 9 kHz ~ 30 MHz: all emissions are more than 20 dB below the limit, therefore do not be recorded in this report.

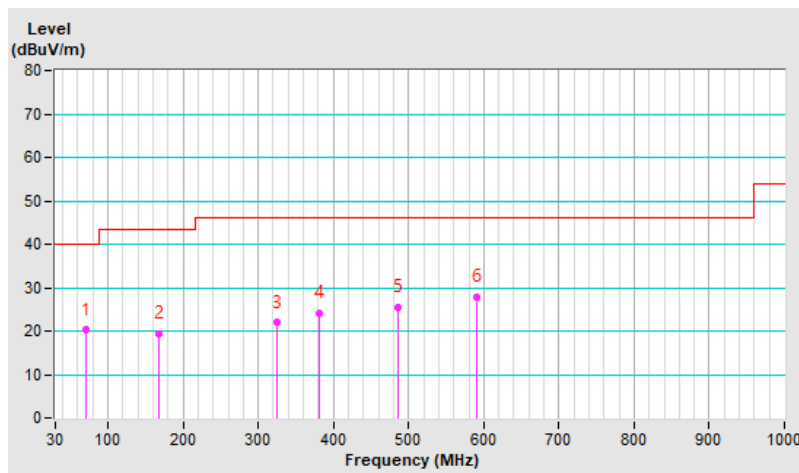

A(Right Earphone)

| | | | |
|------------------------|----------------|--|-------------------------------|
| RF Mode | BT-LE 1M | Channel | CH 0 : 2402 MHz |
| Frequency Range | 30 MHz ~ 1 GHz | Detector Function & Bandwidth | QP: RB=120kHz, DET=Quasi-Peak |
| Input Power | 120 Vac, 60 Hz | Environmental Conditions | 25°C, 75% RH |
| Tested By | William Su | | |

Antenna Polarity & Test Distance : Horizontal at 3 m

| No | Frequency (MHz) | Emission Level (dBuV/m) | Limit (dBuV/m) | Margin (dB) | Antenna Height (m) | Table Angle (Degree) | Raw Value (dBuV) | Correction Factor (dB/m) |
|----|-----------------|-------------------------|----------------|-------------|--------------------|----------------------|------------------|--------------------------|
| 1 | 42.67 | 25.3 QP | 40.0 | -14.7 | 2.28 H | 340 | 34.3 | -9.0 |
| 2 | 97.00 | 23.8 QP | 43.5 | -19.7 | 2.12 H | 269 | 37.5 | -13.7 |
| 3 | 174.50 | 24.5 QP | 43.5 | -19.0 | 1.81 H | 0 | 33.0 | -8.5 |
| 4 | 250.20 | 20.7 QP | 46.0 | -25.3 | 1.89 H | 230 | 28.6 | -7.9 |
| 5 | 300.05 | 24.1 QP | 46.0 | -21.9 | 1.31 H | 142 | 30.0 | -5.9 |
| 6 | 485.94 | 26.7 QP | 46.0 | -19.3 | 1.02 H | 223 | 28.5 | -1.8 |

Remarks:

1. Emission Level(dBuV/m) = Raw Value(dBuV) + Correction Factor(dB/m)
2. Correction Factor(dB/m) = Antenna Factor(dB/m) + Cable Factor(dB) – Pre-Amplifier Factor(dB)
3. Margin value = Emission Level – Limit value
4. The other emission levels were very low against the limit of frequency range 30 MHz ~ 1 GHz.
5. The frequency range 9 kHz ~ 30 MHz: all emissions are more than 20 dB below the limit, therefore do not be recorded in this report.

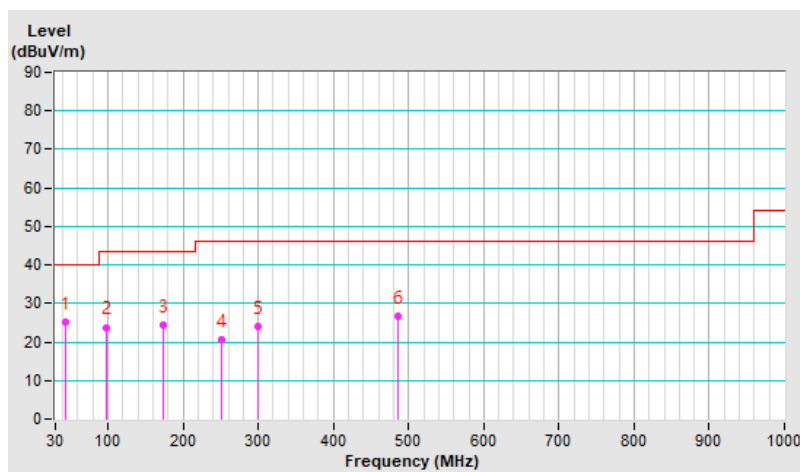

| | | | |
|------------------------|----------------|--|-------------------------------|
| RF Mode | BT-LE 1M | Channel | CH 0 : 2402 MHz |
| Frequency Range | 30 MHz ~ 1 GHz | Detector Function & Bandwidth | QP: RB=120kHz, DET=Quasi-Peak |
| Input Power | 120 Vac, 60 Hz | Environmental Conditions | 25°C, 75% RH |
| Tested By | William Su | | |

| Antenna Polarity & Test Distance : Vertical at 3 m | | | | | | | | |
|--|-----------------|-------------------------|----------------|-------------|--------------------|----------------------|------------------|--------------------------|
| No | Frequency (MHz) | Emission Level (dBuV/m) | Limit (dBuV/m) | Margin (dB) | Antenna Height (m) | Table Angle (Degree) | Raw Value (dBuV) | Correction Factor (dB/m) |
| 1 | 44.30 | 24.3 QP | 40.0 | -15.7 | 1.42 V | 332 | 33.2 | -8.9 |
| 2 | 96.98 | 26.4 QP | 43.5 | -17.1 | 1.89 V | 157 | 40.1 | -13.7 |
| 3 | 166.38 | 19.9 QP | 43.5 | -23.6 | 2.26 V | 257 | 27.8 | -7.9 |
| 4 | 199.56 | 20.3 QP | 43.5 | -23.2 | 1.01 V | 264 | 30.8 | -10.5 |
| 5 | 300.00 | 21.3 QP | 46.0 | -24.7 | 1.92 V | 219 | 27.2 | -5.9 |
| 6 | 486.86 | 26.1 QP | 46.0 | -19.9 | 1.53 V | 338 | 27.9 | -1.8 |

Remarks:

1. Emission Level(dBuV/m) = Raw Value(dBuV) + Correction Factor(dB/m)
2. Correction Factor(dB/m) = Antenna Factor(dB/m) + Cable Factor(dB) – Pre-Amplifier Factor(dB)
3. Margin value = Emission Level – Limit value
4. The other emission levels were very low against the limit of frequency range 30 MHz ~ 1 GHz.
5. The frequency range 9 kHz ~ 30 MHz: all emissions are more than 20 dB below the limit, therefore do not be recorded in this report.

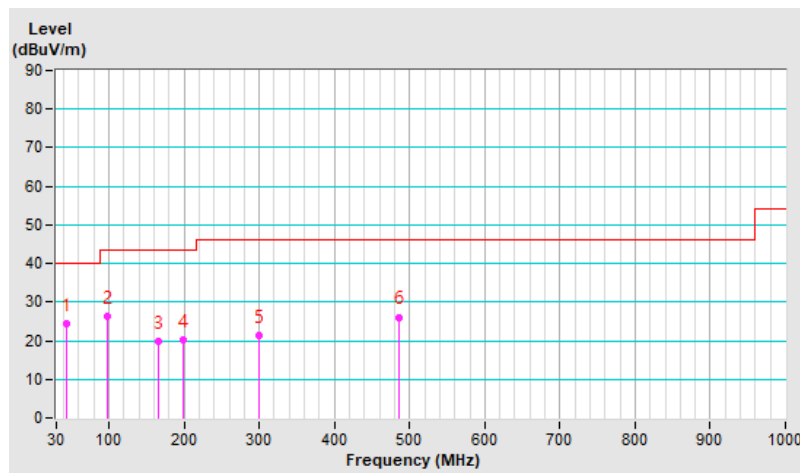

7.7 Unwanted Emissions above 1 GHz

A(Left Earphone)

| | | | |
|------------------------|----------------|--|--|
| RF Mode | BT-LE 1M | Channel | CH 0 : 2402 MHz |
| Frequency Range | 1 GHz ~ 25 GHz | Detector Function & Bandwidth | PK: RB=1 MHz, VB=3 MHz, DET=Peak AV: RB=1 MHz, VB=3 kHz, DET=Peak |
| Input Power | 120 Vac, 60 Hz | Environmental Conditions | 25°C, 75% RH |
| Tested By | Jed Wu | | |

| Antenna Polarity & Test Distance : Horizontal at 3 m | | | | | | | | |
|--|-----------------|-------------------------|----------------|-------------|--------------------|----------------------|------------------|--------------------------|
| No | Frequency (MHz) | Emission Level (dBuV/m) | Limit (dBuV/m) | Margin (dB) | Antenna Height (m) | Table Angle (Degree) | Raw Value (dBuV) | Correction Factor (dB/m) |
| 1 | 2390.00 | 53.5 PK | 74.0 | -20.5 | 3.43 H | 225 | 54.0 | -0.5 |
| 2 | 2390.00 | 40.8 AV | 54.0 | -13.2 | 3.43 H | 225 | 41.3 | -0.5 |
| 3 | *2402.00 | 100.7 PK | | | 3.43 H | 225 | 101.2 | -0.5 |
| 4 | *2402.00 | 100.1 AV | | | 3.43 H | 225 | 100.6 | -0.5 |
| 5 | 4804.00 | 47.9 PK | 74.0 | -26.1 | 1.16 H | 309 | 40.1 | 7.8 |
| 6 | 4804.00 | 34.3 AV | 54.0 | -19.7 | 1.16 H | 309 | 26.5 | 7.8 |

| Antenna Polarity & Test Distance : Vertical at 3 m | | | | | | | | |
|--|-----------------|-------------------------|----------------|-------------|--------------------|----------------------|------------------|--------------------------|
| No | Frequency (MHz) | Emission Level (dBuV/m) | Limit (dBuV/m) | Margin (dB) | Antenna Height (m) | Table Angle (Degree) | Raw Value (dBuV) | Correction Factor (dB/m) |
| 1 | 2390.00 | 53.9 PK | 74.0 | -20.1 | 3.21 V | 274 | 54.4 | -0.5 |
| 2 | 2390.00 | 41.2 AV | 54.0 | -12.8 | 3.21 V | 274 | 41.7 | -0.5 |
| 3 | *2402.00 | 101.5 PK | | | 3.21 V | 274 | 102.0 | -0.5 |
| 4 | *2402.00 | 100.9 AV | | | 3.21 V | 274 | 101.4 | -0.5 |
| 5 | 4804.00 | 48.5 PK | 74.0 | -25.5 | 1.59 V | 291 | 40.7 | 7.8 |
| 6 | 4804.00 | 34.9 AV | 54.0 | -19.1 | 1.59 V | 291 | 27.1 | 7.8 |

Remarks:

1. Emission Level(dBuV/m) = Raw Value(dBuV) + Correction Factor(dB/m)
2. Correction Factor(dB/m) = Antenna Factor(dB/m) + Cable Factor(dB) – Pre-Amplifier Factor(dB)
3. Margin value = Emission Level – Limit value
4. The other emission levels were very low against the limit.
5. " * " : Fundamental frequency, the limit was restricted at the RF Output Power.



| | | | |
|------------------------|----------------|--|--|
| RF Mode | BT-LE 1M | Channel | CH 19 : 2440 MHz |
| Frequency Range | 1 GHz ~ 25 GHz | Detector Function & Bandwidth | PK: RB=1 MHz, VB=3 MHz, DET=Peak AV: RB=1 MHz, VB=3 kHz, DET=Peak |
| Input Power | 120 Vac, 60 Hz | Environmental Conditions | 25°C, 75% RH |
| Tested By | Jed Wu | | |

| Antenna Polarity & Test Distance : Horizontal at 3 m | | | | | | | | |
|--|-----------------|-------------------------|----------------|-------------|--------------------|----------------------|------------------|--------------------------|
| No | Frequency (MHz) | Emission Level (dBuV/m) | Limit (dBuV/m) | Margin (dB) | Antenna Height (m) | Table Angle (Degree) | Raw Value (dBuV) | Correction Factor (dB/m) |
| 1 | *2440.00 | 102.2 PK | | | 3.41 H | 226 | 102.5 | -0.3 |
| 2 | *2440.00 | 101.4 AV | | | 3.41 H | 226 | 101.7 | -0.3 |
| 3 | 4880.00 | 49.3 PK | 74.0 | -24.7 | 1.14 H | 310 | 41.4 | 7.9 |
| 4 | 4880.00 | 35.5 AV | 54.0 | -18.5 | 1.14 H | 310 | 27.6 | 7.9 |
| Antenna Polarity & Test Distance : Vertical at 3 m | | | | | | | | |
| No | Frequency (MHz) | Emission Level (dBuV/m) | Limit (dBuV/m) | Margin (dB) | Antenna Height (m) | Table Angle (Degree) | Raw Value (dBuV) | Correction Factor (dB/m) |
| 1 | *2440.00 | 103.0 PK | | | 3.19 V | 275 | 103.3 | -0.3 |
| 2 | *2440.00 | 102.2 AV | | | 3.19 V | 275 | 102.5 | -0.3 |
| 3 | 4880.00 | 49.9 PK | 74.0 | -24.1 | 1.57 V | 290 | 42.0 | 7.9 |
| 4 | 4880.00 | 36.3 AV | 54.0 | -17.7 | 1.57 V | 290 | 28.4 | 7.9 |

Remarks:

1. Emission Level(dBuV/m) = Raw Value(dBuV) + Correction Factor(dB/m)
2. Correction Factor(dB/m) = Antenna Factor(dB/m) + Cable Factor(dB) – Pre-Amplifier Factor(dB)
3. Margin value = Emission Level – Limit value
4. The other emission levels were very low against the limit.
5. " * " : Fundamental frequency, the limit was restricted at the RF Output Power.



| | | | |
|------------------------|----------------|--|--|
| RF Mode | BT-LE 1M | Channel | CH 39 : 2480 MHz |
| Frequency Range | 1 GHz ~ 25 GHz | Detector Function & Bandwidth | PK: RB=1 MHz, VB=3 MHz, DET=Peak AV: RB=1 MHz, VB=3 kHz, DET=Peak |
| Input Power | 120 Vac, 60 Hz | Environmental Conditions | 25°C, 75% RH |
| Tested By | Jed Wu | | |

Antenna Polarity & Test Distance : Horizontal at 3 m

| No | Frequency (MHz) | Emission Level (dBuV/m) | Limit (dBuV/m) | Margin (dB) | Antenna Height (m) | Table Angle (Degree) | Raw Value (dBuV) | Correction Factor (dB/m) |
|----|-----------------|-------------------------|----------------|-------------|--------------------|----------------------|------------------|--------------------------|
| 1 | *2480.00 | 103.0 PK | | | 2.80 H | 220 | 103.2 | -0.2 |
| 2 | *2480.00 | 102.4 AV | | | 2.80 H | 220 | 102.6 | -0.2 |
| 3 | 2483.50 | 54.2 PK | 74.0 | -19.8 | 2.80 H | 220 | 54.4 | -0.2 |
| 4 | 2483.50 | 41.4 AV | 54.0 | -12.6 | 2.80 H | 220 | 41.6 | -0.2 |
| 5 | 4960.00 | 50.1 PK | 74.0 | -23.9 | 1.79 H | 304 | 42.1 | 8.0 |
| 6 | 4960.00 | 36.5 AV | 54.0 | -17.5 | 1.79 H | 304 | 28.5 | 8.0 |

Antenna Polarity & Test Distance : Vertical at 3 m

| No | Frequency (MHz) | Emission Level (dBuV/m) | Limit (dBuV/m) | Margin (dB) | Antenna Height (m) | Table Angle (Degree) | Raw Value (dBuV) | Correction Factor (dB/m) |
|----|-----------------|-------------------------|----------------|-------------|--------------------|----------------------|------------------|--------------------------|
| 1 | *2480.00 | 103.8 PK | | | 3.84 V | 269 | 104.0 | -0.2 |
| 2 | *2480.00 | 103.2 AV | | | 3.84 V | 269 | 103.4 | -0.2 |
| 3 | 2483.50 | 54.6 PK | 74.0 | -19.4 | 3.84 V | 269 | 54.8 | -0.2 |
| 4 | 2483.50 | 41.8 AV | 54.0 | -12.2 | 3.84 V | 269 | 42.0 | -0.2 |
| 5 | 4960.00 | 50.7 PK | 74.0 | -23.3 | 2.22 V | 286 | 42.7 | 8.0 |
| 6 | 4960.00 | 37.1 AV | 54.0 | -16.9 | 2.22 V | 286 | 29.1 | 8.0 |

Remarks:

1. Emission Level(dBuV/m) = Raw Value(dBuV) + Correction Factor(dB/m)
2. Correction Factor(dB/m) = Antenna Factor(dB/m) + Cable Factor(dB) – Pre-Amplifier Factor(dB)
3. Margin value = Emission Level – Limit value
4. The other emission levels were very low against the limit.
5. " * ": Fundamental frequency, the limit was restricted at the RF Output Power.



| | | | |
|------------------------|----------------|--|--|
| RF Mode | BT-LE 2M | Channel | CH 0 : 2402 MHz |
| Frequency Range | 1 GHz ~ 25 GHz | Detector Function & Bandwidth | PK: RB=1 MHz, VB=3 MHz, DET=Peak AV: RB=1 MHz, VB=1 kHz, DET=Peak |
| Input Power | 120 Vac, 60 Hz | Environmental Conditions | 25°C, 75% RH |
| Tested By | Jed Wu | | |

Antenna Polarity & Test Distance : Horizontal at 3 m

| No | Frequency (MHz) | Emission Level (dBuV/m) | Limit (dBuV/m) | Margin (dB) | Antenna Height (m) | Table Angle (Degree) | Raw Value (dBuV) | Correction Factor (dB/m) |
|----|-----------------|-------------------------|----------------|-------------|--------------------|----------------------|------------------|--------------------------|
| 1 | 2390.00 | 54.0 PK | 74.0 | -20.0 | 3.44 H | 227 | 54.5 | -0.5 |
| 2 | 2390.00 | 40.1 AV | 54.0 | -13.9 | 3.44 H | 227 | 40.6 | -0.5 |
| 3 | *2402.00 | 100.6 PK | | | 3.44 H | 227 | 101.1 | -0.5 |
| 4 | *2402.00 | 99.0 AV | | | 3.44 H | 227 | 99.5 | -0.5 |
| 5 | 4804.00 | 47.8 PK | 74.0 | -26.2 | 1.16 H | 311 | 40.0 | 7.8 |
| 6 | 4804.00 | 33.2 AV | 54.0 | -20.8 | 1.16 H | 311 | 25.4 | 7.8 |

Antenna Polarity & Test Distance : Vertical at 3 m

| No | Frequency (MHz) | Emission Level (dBuV/m) | Limit (dBuV/m) | Margin (dB) | Antenna Height (m) | Table Angle (Degree) | Raw Value (dBuV) | Correction Factor (dB/m) |
|----|-----------------|-------------------------|----------------|-------------|--------------------|----------------------|------------------|--------------------------|
| 1 | 2390.00 | 54.5 PK | 74.0 | -19.5 | 3.21 V | 276 | 55.0 | -0.5 |
| 2 | 2390.00 | 40.5 AV | 54.0 | -13.5 | 3.21 V | 276 | 41.0 | -0.5 |
| 3 | *2402.00 | 101.5 PK | | | 3.21 V | 276 | 102.0 | -0.5 |
| 4 | *2402.00 | 99.8 AV | | | 3.21 V | 276 | 100.3 | -0.5 |
| 5 | 4804.00 | 48.4 PK | 74.0 | -25.6 | 1.60 V | 293 | 40.6 | 7.8 |
| 6 | 4804.00 | 33.8 AV | 54.0 | -20.2 | 1.60 V | 293 | 26.0 | 7.8 |

Remarks:

1. Emission Level(dBuV/m) = Raw Value(dBuV) + Correction Factor(dB/m)
2. Correction Factor(dB/m) = Antenna Factor(dB/m) + Cable Factor(dB) – Pre-Amplifier Factor(dB)
3. Margin value = Emission Level – Limit value
4. The other emission levels were very low against the limit.
5. " * ": Fundamental frequency, the limit was restricted at the RF Output Power.



| | | | |
|------------------------|----------------|--|--|
| RF Mode | BT-LE 2M | Channel | CH 19 : 2440 MHz |
| Frequency Range | 1 GHz ~ 25 GHz | Detector Function & Bandwidth | PK: RB=1 MHz, VB=3 MHz, DET=Peak AV: RB=1 MHz, VB=1 kHz, DET=Peak |
| Input Power | 120 Vac, 60 Hz | Environmental Conditions | 25°C, 75% RH |
| Tested By | Jed Wu | | |

Antenna Polarity & Test Distance : Horizontal at 3 m

| No | Frequency (MHz) | Emission Level (dBuV/m) | Limit (dBuV/m) | Margin (dB) | Antenna Height (m) | Table Angle (Degree) | Raw Value (dBuV) | Correction Factor (dB/m) |
|----|-----------------|-------------------------|----------------|-------------|--------------------|----------------------|------------------|--------------------------|
| 1 | *2440.00 | 102.5 PK | | | 3.72 H | 223 | 102.8 | -0.3 |
| 2 | *2440.00 | 100.8 AV | | | 3.72 H | 223 | 101.1 | -0.3 |
| 3 | 4880.00 | 49.6 PK | 74.0 | -24.4 | 1.45 H | 307 | 41.7 | 7.9 |
| 4 | 4880.00 | 36.0 AV | 54.0 | -18.0 | 1.45 H | 307 | 28.1 | 7.9 |

Antenna Polarity & Test Distance : Vertical at 3 m

| No | Frequency (MHz) | Emission Level (dBuV/m) | Limit (dBuV/m) | Margin (dB) | Antenna Height (m) | Table Angle (Degree) | Raw Value (dBuV) | Correction Factor (dB/m) |
|----|-----------------|-------------------------|----------------|-------------|--------------------|----------------------|------------------|--------------------------|
| 1 | *2440.00 | 103.3 PK | | | 3.50 V | 272 | 103.6 | -0.3 |
| 2 | *2440.00 | 101.6 AV | | | 3.50 V | 272 | 101.9 | -0.3 |
| 3 | 4880.00 | 50.2 PK | 74.0 | -23.8 | 1.88 V | 289 | 42.3 | 7.9 |
| 4 | 4880.00 | 36.6 AV | 54.0 | -17.4 | 1.88 V | 289 | 28.7 | 7.9 |

Remarks:

1. Emission Level(dBuV/m) = Raw Value(dBuV) + Correction Factor(dB/m)
2. Correction Factor(dB/m) = Antenna Factor(dB/m) + Cable Factor(dB) – Pre-Amplifier Factor(dB)
3. Margin value = Emission Level – Limit value
4. The other emission levels were very low against the limit.
5. " * " : Fundamental frequency, the limit was restricted at the RF Output Power.



| | | | |
|------------------------|----------------|--|--|
| RF Mode | BT-LE 2M | Channel | CH 39 : 2480 MHz |
| Frequency Range | 1 GHz ~ 25 GHz | Detector Function & Bandwidth | PK: RB=1 MHz, VB=3 MHz, DET=Peak AV: RB=1 MHz, VB=1 kHz, DET=Peak |
| Input Power | 120 Vac, 60 Hz | Environmental Conditions | 25°C, 75% RH |
| Tested By | Jed Wu | | |

Antenna Polarity & Test Distance : Horizontal at 3 m

| No | Frequency (MHz) | Emission Level (dBuV/m) | Limit (dBuV/m) | Margin (dB) | Antenna Height (m) | Table Angle (Degree) | Raw Value (dBuV) | Correction Factor (dB/m) |
|----|-----------------|-------------------------|----------------|-------------|--------------------|----------------------|------------------|--------------------------|
| 1 | *2480.00 | 102.8 PK | | | 2.79 H | 221 | 103.0 | -0.2 |
| 2 | *2480.00 | 101.1 AV | | | 2.79 H | 221 | 101.3 | -0.2 |
| 3 | 2483.50 | 56.2 PK | 74.0 | -17.8 | 2.79 H | 221 | 56.4 | -0.2 |
| 4 | 2483.50 | 44.9 AV | 54.0 | -9.1 | 2.79 H | 221 | 45.1 | -0.2 |
| 5 | 4960.00 | 49.9 PK | 74.0 | -24.1 | 1.80 H | 304 | 41.9 | 8.0 |
| 6 | 4960.00 | 36.3 AV | 54.0 | -17.7 | 1.80 H | 304 | 28.3 | 8.0 |

Antenna Polarity & Test Distance : Vertical at 3 m

| No | Frequency (MHz) | Emission Level (dBuV/m) | Limit (dBuV/m) | Margin (dB) | Antenna Height (m) | Table Angle (Degree) | Raw Value (dBuV) | Correction Factor (dB/m) |
|----------|-----------------|-------------------------|----------------|-------------|--------------------|----------------------|------------------|--------------------------|
| 1 | *2480.00 | 103.6 PK | | | 3.85 V | 270 | 103.8 | -0.2 |
| 2 | *2480.00 | 102.0 AV | | | 3.85 V | 270 | 102.2 | -0.2 |
| 3 | 2483.50 | 56.4 PK | 74.0 | -17.6 | 3.85 V | 270 | 56.6 | -0.2 |
| 4 | 2483.50 | 45.1 AV | 54.0 | -8.9 | 3.85 V | 270 | 45.3 | -0.2 |
| 5 | 4960.00 | 50.5 PK | 74.0 | -23.5 | 2.23 V | 287 | 42.5 | 8.0 |
| 6 | 4960.00 | 36.9 AV | 54.0 | -17.1 | 2.23 V | 287 | 28.9 | 8.0 |

Remarks:

1. Emission Level(dBuV/m) = Raw Value(dBuV) + Correction Factor(dB/m)
2. Correction Factor(dB/m) = Antenna Factor(dB/m) + Cable Factor(dB) – Pre-Amplifier Factor(dB)
3. Margin value = Emission Level – Limit value
4. The other emission levels were very low against the limit.
5. " * ": Fundamental frequency, the limit was restricted at the RF Output Power.

A(Left Earphone)_Plot of Band Edge

| | | | |
|-----------------|--------------------|-------------------------------|--|
| Frequency Range | 2.31 GHz ~ 2.5 GHz | Detector Function & Bandwidth | PK: RB=1 MHz, VB=3 MHz, DET=Peak AV: RB=1 MHz, VB=3 kHz, DET=Peak |
|-----------------|--------------------|-------------------------------|--|

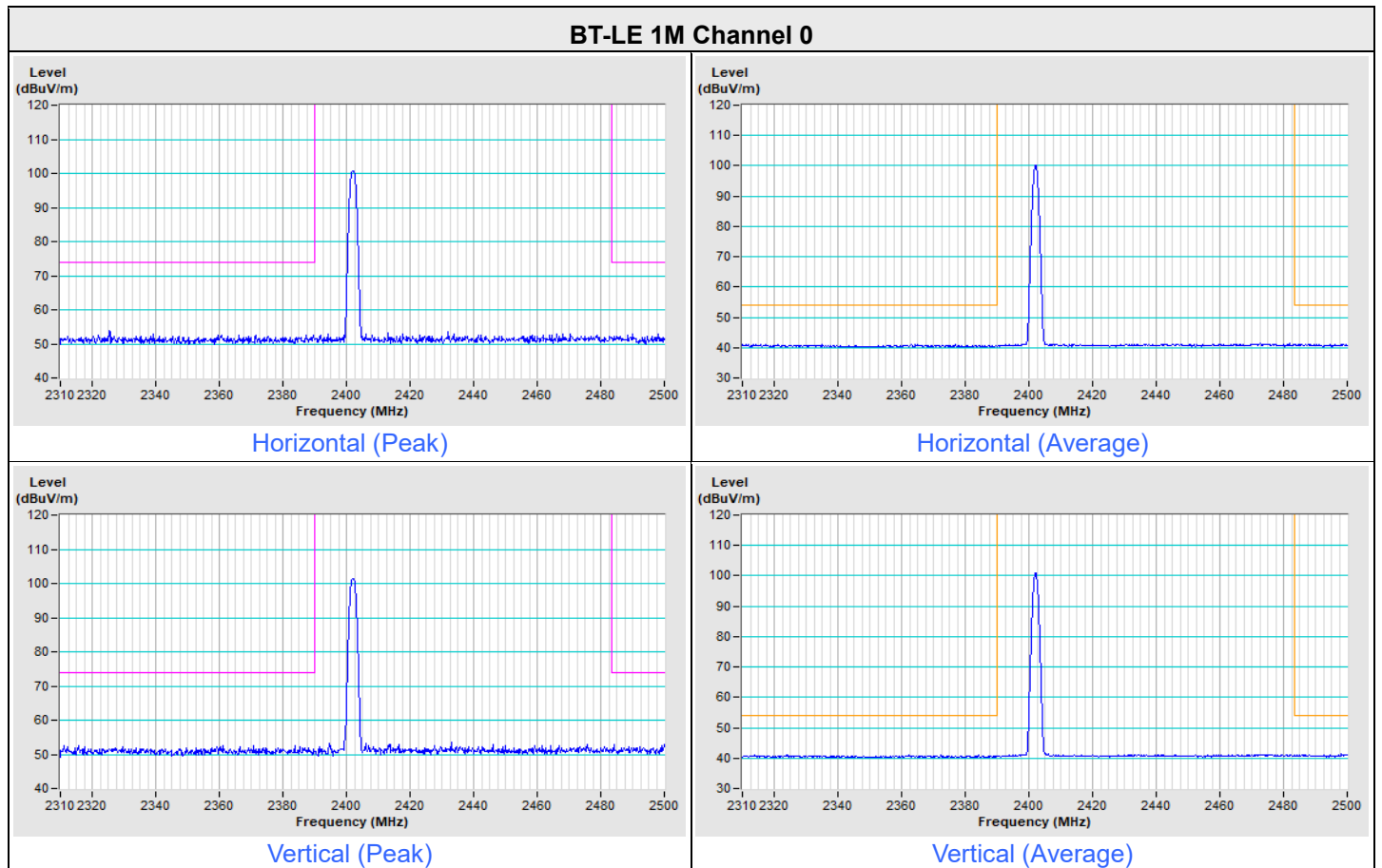

BT-LE 1M Channel 39

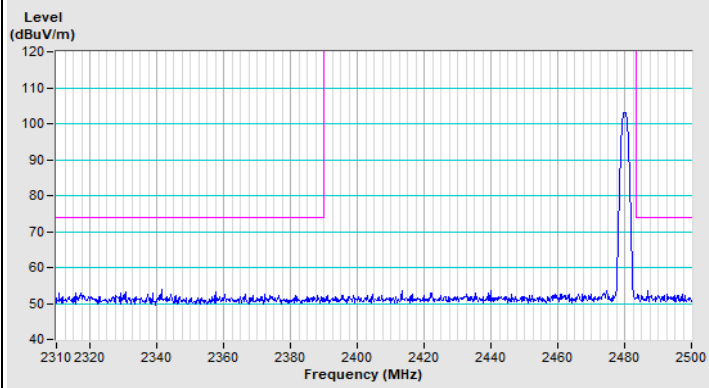

Horizontal (Peak)

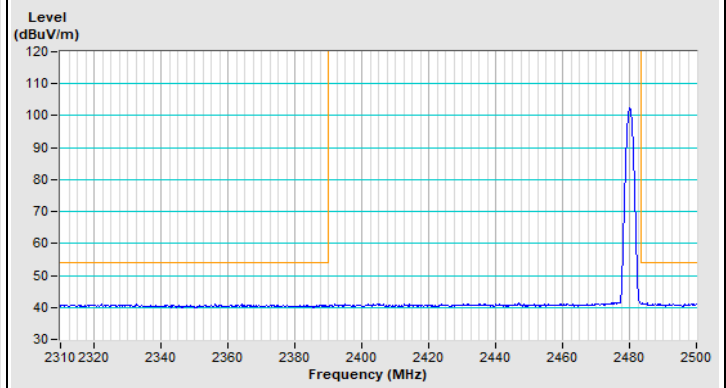

Horizontal (Average)

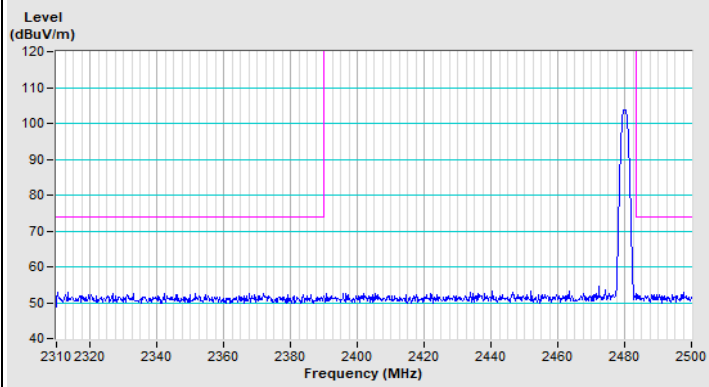

Vertical (Peak)

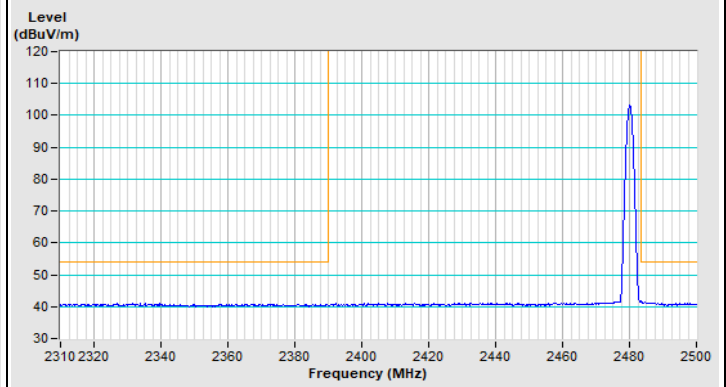

Vertical (Average)

| | | | |
|-----------------|--------------------|-------------------------------|--|
| Frequency Range | 2.31 GHz ~ 2.5 GHz | Detector Function & Bandwidth | PK: RB=1 MHz, VB=3 MHz, DET=Peak AV: RB=1 MHz, VB=1 kHz, DET=Peak |
|-----------------|--------------------|-------------------------------|--|

BT-LE 2M Channel 0

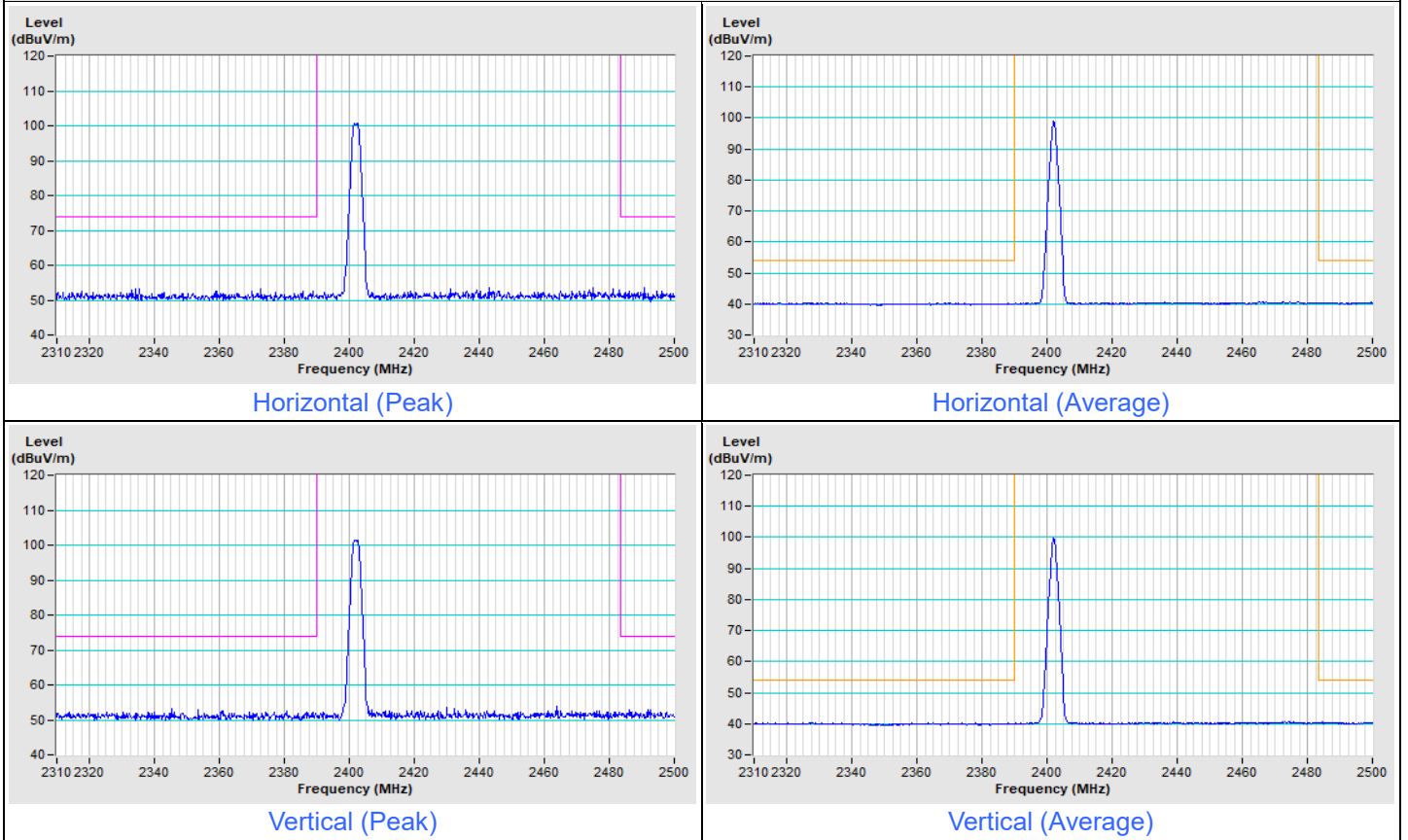

BT-LE 2M Channel 39

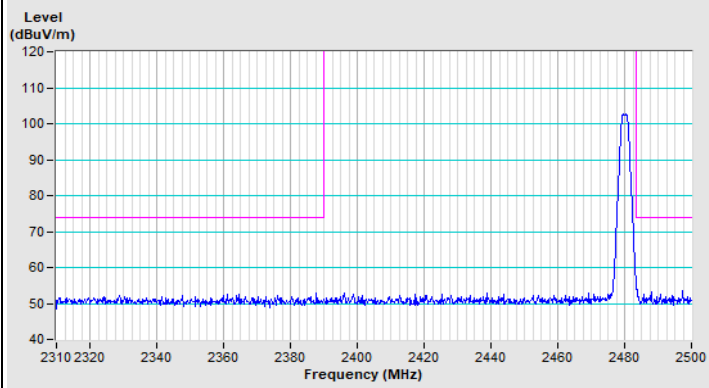

Horizontal (Peak)

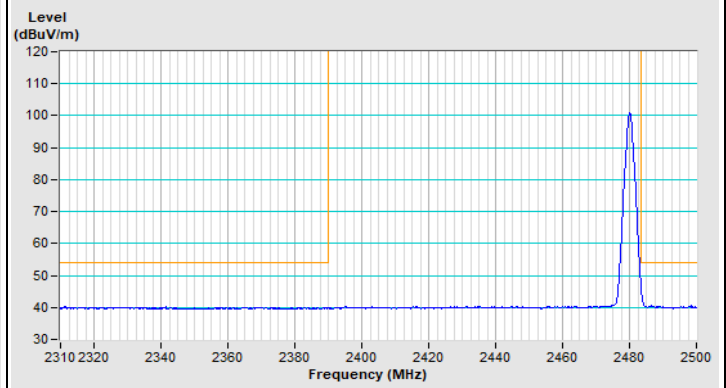

Horizontal (Average)

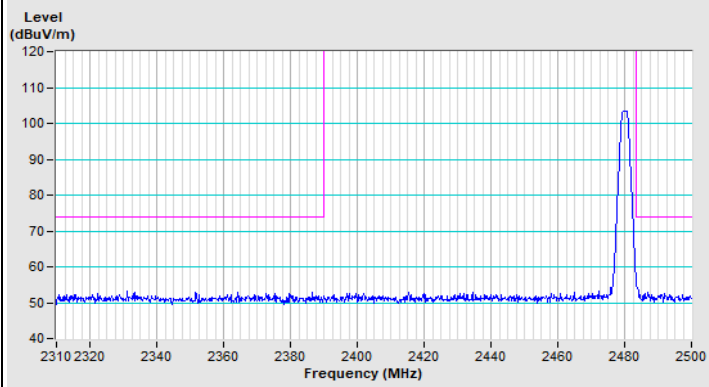

Vertical (Peak)

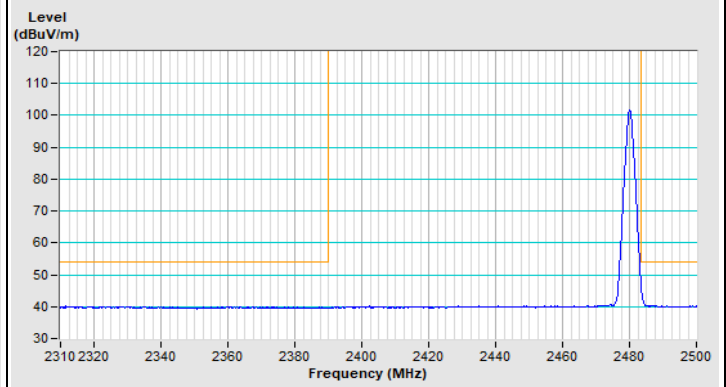

Vertical (Average)

A(Right Earphone)

| | | | |
|------------------------|----------------|--|--|
| RF Mode | BT-LE 1M | Channel | CH 0 : 2402 MHz |
| Frequency Range | 1 GHz ~ 25 GHz | Detector Function & Bandwidth | PK: RB=1 MHz, VB=3 MHz, DET=Peak AV: RB=1 MHz, VB=3 kHz, DET=Peak |
| Input Power | 120 Vac, 60 Hz | Environmental Conditions | 25°C, 75% RH |
| Tested By | Jed Wu | | |

| Antenna Polarity & Test Distance : Horizontal at 3 m | | | | | | | | |
|---|-----------------|-------------------------|----------------|-------------|--------------------|----------------------|------------------|--------------------------|
| No | Frequency (MHz) | Emission Level (dBuV/m) | Limit (dBuV/m) | Margin (dB) | Antenna Height (m) | Table Angle (Degree) | Raw Value (dBuV) | Correction Factor (dB/m) |
| 1 | 2390.00 | 53.1 PK | 74.0 | -20.9 | 3.34 H | 154 | 53.6 | -0.5 |
| 2 | 2390.00 | 40.6 AV | 54.0 | -13.4 | 3.34 H | 154 | 41.1 | -0.5 |
| 3 | *2402.00 | 97.1 PK | | | 3.34 H | 154 | 97.6 | -0.5 |
| 4 | *2402.00 | 96.5 AV | | | 3.34 H | 154 | 97.0 | -0.5 |
| 5 | 4804.00 | 48.0 PK | 74.0 | -26.0 | 3.06 H | 137 | 40.2 | 7.8 |
| 6 | 4804.00 | 37.6 AV | 54.0 | -16.4 | 3.06 H | 137 | 29.8 | 7.8 |
| Antenna Polarity & Test Distance : Vertical at 3 m | | | | | | | | |
| No | Frequency (MHz) | Emission Level (dBuV/m) | Limit (dBuV/m) | Margin (dB) | Antenna Height (m) | Table Angle (Degree) | Raw Value (dBuV) | Correction Factor (dB/m) |
| 1 | 2390.00 | 54.0 PK | 74.0 | -20.0 | 3.21 V | 110 | 54.5 | -0.5 |
| 2 | 2390.00 | 41.5 AV | 54.0 | -12.5 | 3.21 V | 110 | 42.0 | -0.5 |
| 3 | *2402.00 | 100.3 PK | | | 3.21 V | 110 | 100.8 | -0.5 |
| 4 | *2402.00 | 99.7 AV | | | 3.21 V | 110 | 100.2 | -0.5 |
| 5 | 4804.00 | 47.1 PK | 74.0 | -26.9 | 3.36 V | 186 | 39.3 | 7.8 |
| 6 | 4804.00 | 36.7 AV | 54.0 | -17.3 | 3.36 V | 186 | 28.9 | 7.8 |

Remarks:

1. Emission Level(dBuV/m) = Raw Value(dBuV) + Correction Factor(dB/m)
2. Correction Factor(dB/m) = Antenna Factor(dB/m) + Cable Factor(dB) – Pre-Amplifier Factor(dB)
3. Margin value = Emission Level – Limit value
4. The other emission levels were very low against the limit.
5. " * ": Fundamental frequency, the limit was restricted at the RF Output Power.



| | | | |
|------------------------|----------------|--|--|
| RF Mode | BT-LE 1M | Channel | CH 19 : 2440 MHz |
| Frequency Range | 1 GHz ~ 25 GHz | Detector Function & Bandwidth | PK: RB=1 MHz, VB=3 MHz, DET=Peak AV: RB=1 MHz, VB=3 kHz, DET=Peak |
| Input Power | 120 Vac, 60 Hz | Environmental Conditions | 25°C, 75% RH |
| Tested By | Jed Wu | | |

| Antenna Polarity & Test Distance : Horizontal at 3 m | | | | | | | | |
|--|-----------------|-------------------------|----------------|-------------|--------------------|----------------------|------------------|--------------------------|
| No | Frequency (MHz) | Emission Level (dBuV/m) | Limit (dBuV/m) | Margin (dB) | Antenna Height (m) | Table Angle (Degree) | Raw Value (dBuV) | Correction Factor (dB/m) |
| 1 | *2440.00 | 97.6 PK | | | 3.28 H | 156 | 97.9 | -0.3 |
| 2 | *2440.00 | 97.0 AV | | | 3.28 H | 156 | 97.3 | -0.3 |
| 3 | 4880.00 | 48.4 PK | 74.0 | -25.6 | 3.00 H | 139 | 40.5 | 7.9 |
| 4 | 4880.00 | 38.0 AV | 54.0 | -16.0 | 3.00 H | 139 | 30.1 | 7.9 |

| Antenna Polarity & Test Distance : Vertical at 3 m | | | | | | | | |
|--|-----------------|-------------------------|----------------|-------------|--------------------|----------------------|------------------|--------------------------|
| No | Frequency (MHz) | Emission Level (dBuV/m) | Limit (dBuV/m) | Margin (dB) | Antenna Height (m) | Table Angle (Degree) | Raw Value (dBuV) | Correction Factor (dB/m) |
| 1 | *2440.00 | 100.8 PK | | | 3.15 V | 112 | 101.1 | -0.3 |
| 2 | *2440.00 | 100.2 AV | | | 3.15 V | 112 | 100.5 | -0.3 |
| 3 | 4880.00 | 47.5 PK | 74.0 | -26.5 | 3.30 V | 188 | 39.6 | 7.9 |
| 4 | 4880.00 | 37.1 AV | 54.0 | -16.9 | 3.30 V | 188 | 29.2 | 7.9 |

Remarks:

1. Emission Level(dBuV/m) = Raw Value(dBuV) + Correction Factor(dB/m)
2. Correction Factor(dB/m) = Antenna Factor(dB/m) + Cable Factor(dB) – Pre-Amplifier Factor(dB)
3. Margin value = Emission Level – Limit value
4. The other emission levels were very low against the limit.
5. " * " : Fundamental frequency, the limit was restricted at the RF Output Power.



| | | | |
|------------------------|----------------|--|--|
| RF Mode | BT-LE 1M | Channel | CH 39 : 2480 MHz |
| Frequency Range | 1 GHz ~ 25 GHz | Detector Function & Bandwidth | PK: RB=1 MHz, VB=3 MHz, DET=Peak AV: RB=1 MHz, VB=3 kHz, DET=Peak |
| Input Power | 120 Vac, 60 Hz | Environmental Conditions | 25°C, 75% RH |
| Tested By | Jed Wu | | |

Antenna Polarity & Test Distance : Horizontal at 3 m

| No | Frequency (MHz) | Emission Level (dBuV/m) | Limit (dBuV/m) | Margin (dB) | Antenna Height (m) | Table Angle (Degree) | Raw Value (dBuV) | Correction Factor (dB/m) |
|----|-----------------|-------------------------|----------------|-------------|--------------------|----------------------|------------------|--------------------------|
| 1 | *2480.00 | 98.0 PK | | | 3.16 H | 156 | 98.2 | -0.2 |
| 2 | *2480.00 | 97.3 AV | | | 3.16 H | 156 | 97.5 | -0.2 |
| 3 | 2483.50 | 53.5 PK | 74.0 | -20.5 | 3.16 H | 156 | 53.7 | -0.2 |
| 4 | 2483.50 | 41.3 AV | 54.0 | -12.7 | 3.16 H | 156 | 41.5 | -0.2 |
| 5 | 4960.00 | 48.8 PK | 74.0 | -25.2 | 2.88 H | 139 | 40.8 | 8.0 |
| 6 | 4960.00 | 38.4 AV | 54.0 | -15.6 | 2.88 H | 139 | 30.4 | 8.0 |

Antenna Polarity & Test Distance : Vertical at 3 m

| No | Frequency (MHz) | Emission Level (dBuV/m) | Limit (dBuV/m) | Margin (dB) | Antenna Height (m) | Table Angle (Degree) | Raw Value (dBuV) | Correction Factor (dB/m) |
|----|-----------------|-------------------------|----------------|-------------|--------------------|----------------------|------------------|--------------------------|
| 1 | *2480.00 | 101.2 PK | | | 3.03 V | 112 | 101.4 | -0.2 |
| 2 | *2480.00 | 100.6 AV | | | 3.03 V | 112 | 100.8 | -0.2 |
| 3 | 2483.50 | 53.7 PK | 74.0 | -20.3 | 3.03 V | 112 | 53.9 | -0.2 |
| 4 | 2483.50 | 41.5 AV | 54.0 | -12.5 | 3.03 V | 112 | 41.7 | -0.2 |
| 5 | 4960.00 | 47.9 PK | 74.0 | -26.1 | 3.18 V | 184 | 39.9 | 8.0 |
| 6 | 4960.00 | 37.5 AV | 54.0 | -16.5 | 3.18 V | 184 | 29.5 | 8.0 |

Remarks:

1. Emission Level(dBuV/m) = Raw Value(dBuV) + Correction Factor(dB/m)
2. Correction Factor(dB/m) = Antenna Factor(dB/m) + Cable Factor(dB) – Pre-Amplifier Factor(dB)
3. Margin value = Emission Level – Limit value
4. The other emission levels were very low against the limit.
5. " * ": Fundamental frequency, the limit was restricted at the RF Output Power.



| | | | |
|------------------------|----------------|--|--|
| RF Mode | BT-LE 2M | Channel | CH 0 : 2402 MHz |
| Frequency Range | 1 GHz ~ 25 GHz | Detector Function & Bandwidth | PK: RB=1 MHz, VB=3 MHz, DET=Peak AV: RB=1 MHz, VB=1 kHz, DET=Peak |
| Input Power | 120 Vac, 60 Hz | Environmental Conditions | 25°C, 75% RH |
| Tested By | Jed Wu | | |

Antenna Polarity & Test Distance : Horizontal at 3 m

| No | Frequency (MHz) | Emission Level (dBuV/m) | Limit (dBuV/m) | Margin (dB) | Antenna Height (m) | Table Angle (Degree) | Raw Value (dBuV) | Correction Factor (dB/m) |
|----|-----------------|-------------------------|----------------|-------------|--------------------|----------------------|------------------|--------------------------|
| 1 | 2390.00 | 53.8 PK | 74.0 | -20.2 | 3.33 H | 155 | 54.3 | -0.5 |
| 2 | 2390.00 | 40.1 AV | 54.0 | -13.9 | 3.33 H | 155 | 40.6 | -0.5 |
| 3 | *2402.00 | 97.0 PK | | | 3.33 H | 155 | 97.5 | -0.5 |
| 4 | *2402.00 | 95.3 AV | | | 3.33 H | 155 | 95.8 | -0.5 |
| 5 | 4804.00 | 47.9 PK | 74.0 | -26.1 | 3.05 H | 138 | 40.1 | 7.8 |
| 6 | 4804.00 | 36.4 AV | 54.0 | -17.6 | 3.05 H | 138 | 28.6 | 7.8 |

Antenna Polarity & Test Distance : Vertical at 3 m

| No | Frequency (MHz) | Emission Level (dBuV/m) | Limit (dBuV/m) | Margin (dB) | Antenna Height (m) | Table Angle (Degree) | Raw Value (dBuV) | Correction Factor (dB/m) |
|----|-----------------|-------------------------|----------------|-------------|--------------------|----------------------|------------------|--------------------------|
| 1 | 2390.00 | 54.4 PK | 74.0 | -19.6 | 3.21 V | 111 | 54.9 | -0.5 |
| 2 | 2390.00 | 40.7 AV | 54.0 | -13.3 | 3.21 V | 111 | 41.2 | -0.5 |
| 3 | *2402.00 | 100.2 PK | | | 3.21 V | 111 | 100.7 | -0.5 |
| 4 | *2402.00 | 98.5 AV | | | 3.21 V | 111 | 99.0 | -0.5 |
| 5 | 4804.00 | 47.0 PK | 74.0 | -27.0 | 3.35 V | 185 | 39.2 | 7.8 |
| 6 | 4804.00 | 35.5 AV | 54.0 | -18.5 | 3.35 V | 185 | 27.7 | 7.8 |

Remarks:

1. Emission Level(dBuV/m) = Raw Value(dBuV) + Correction Factor(dB/m)
2. Correction Factor(dB/m) = Antenna Factor(dB/m) + Cable Factor(dB) – Pre-Amplifier Factor(dB)
3. Margin value = Emission Level – Limit value
4. The other emission levels were very low against the limit.
5. " * ": Fundamental frequency, the limit was restricted at the RF Output Power.



| | | | |
|------------------------|----------------|--|--|
| RF Mode | BT-LE 2M | Channel | CH 19 : 2440 MHz |
| Frequency Range | 1 GHz ~ 25 GHz | Detector Function & Bandwidth | PK: RB=1 MHz, VB=3 MHz, DET=Peak AV: RB=1 MHz, VB=1 kHz, DET=Peak |
| Input Power | 120 Vac, 60 Hz | Environmental Conditions | 25°C, 75% RH |
| Tested By | Jed Wu | | |

Antenna Polarity & Test Distance : Horizontal at 3 m

| No | Frequency (MHz) | Emission Level (dBuV/m) | Limit (dBuV/m) | Margin (dB) | Antenna Height (m) | Table Angle (Degree) | Raw Value (dBuV) | Correction Factor (dB/m) |
|----|-----------------|-------------------------|----------------|-------------|--------------------|----------------------|------------------|--------------------------|
| 1 | *2440.00 | 97.6 PK | | | 3.25 H | 156 | 97.9 | -0.3 |
| 2 | *2440.00 | 95.9 AV | | | 3.25 H | 156 | 96.2 | -0.3 |
| 3 | 4880.00 | 48.4 PK | 74.0 | -25.6 | 2.97 H | 137 | 40.5 | 7.9 |
| 4 | 4880.00 | 36.9 AV | 54.0 | -17.1 | 2.97 H | 137 | 29.0 | 7.9 |

Antenna Polarity & Test Distance : Vertical at 3 m

| No | Frequency (MHz) | Emission Level (dBuV/m) | Limit (dBuV/m) | Margin (dB) | Antenna Height (m) | Table Angle (Degree) | Raw Value (dBuV) | Correction Factor (dB/m) |
|----|-----------------|-------------------------|----------------|-------------|--------------------|----------------------|------------------|--------------------------|
| 1 | *2440.00 | 100.8 PK | | | 3.13 V | 112 | 101.1 | -0.3 |
| 2 | *2440.00 | 99.1 AV | | | 3.13 V | 112 | 99.4 | -0.3 |
| 3 | 4880.00 | 47.5 PK | 74.0 | -26.5 | 3.27 V | 184 | 39.6 | 7.9 |
| 4 | 4880.00 | 36.0 AV | 54.0 | -18.0 | 3.27 V | 184 | 28.1 | 7.9 |

Remarks:

1. Emission Level(dBuV/m) = Raw Value(dBuV) + Correction Factor(dB/m)
2. Correction Factor(dB/m) = Antenna Factor(dB/m) + Cable Factor(dB) – Pre-Amplifier Factor(dB)
3. Margin value = Emission Level – Limit value
4. The other emission levels were very low against the limit.
5. " * " : Fundamental frequency, the limit was restricted at the RF Output Power.

| | | | |
|------------------------|----------------|--|--|
| RF Mode | BT-LE 2M | Channel | CH 39 : 2480 MHz |
| Frequency Range | 1 GHz ~ 25 GHz | Detector Function & Bandwidth | PK: RB=1 MHz, VB=3 MHz, DET=Peak AV: RB=1 MHz, VB=1 kHz, DET=Peak |
| Input Power | 120 Vac, 60 Hz | Environmental Conditions | 25°C, 75% RH |
| Tested By | Jed Wu | | |

Antenna Polarity & Test Distance : Horizontal at 3 m

| No | Frequency (MHz) | Emission Level (dBuV/m) | Limit (dBuV/m) | Margin (dB) | Antenna Height (m) | Table Angle (Degree) | Raw Value (dBuV) | Correction Factor (dB/m) |
|----|-----------------|-------------------------|----------------|-------------|--------------------|----------------------|------------------|--------------------------|
| 1 | *2480.00 | 98.2 PK | | | 3.15 H | 157 | 98.4 | -0.2 |
| 2 | *2480.00 | 96.5 AV | | | 3.15 H | 157 | 96.7 | -0.2 |
| 3 | 2483.50 | 54.6 PK | 74.0 | -19.4 | 3.15 H | 157 | 54.8 | -0.2 |
| 4 | 2483.50 | 42.5 AV | 54.0 | -11.5 | 3.15 H | 157 | 42.7 | -0.2 |
| 5 | 4960.00 | 48.9 PK | 74.0 | -25.1 | 2.87 H | 140 | 40.9 | 8.0 |
| 6 | 4960.00 | 37.4 AV | 54.0 | -16.6 | 2.87 H | 140 | 29.4 | 8.0 |

Antenna Polarity & Test Distance : Vertical at 3 m

| No | Frequency (MHz) | Emission Level (dBuV/m) | Limit (dBuV/m) | Margin (dB) | Antenna Height (m) | Table Angle (Degree) | Raw Value (dBuV) | Correction Factor (dB/m) |
|----|-----------------|-------------------------|----------------|-------------|--------------------|----------------------|------------------|--------------------------|
| 1 | *2480.00 | 101.3 PK | | | 3.03 V | 113 | 101.5 | -0.2 |
| 2 | *2480.00 | 99.6 AV | | | 3.03 V | 113 | 99.8 | -0.2 |
| 3 | 2483.50 | 55.6 PK | 74.0 | -18.4 | 3.03 V | 113 | 55.8 | -0.2 |
| 4 | 2483.50 | 44.0 AV | 54.0 | -10.0 | 3.03 V | 113 | 44.2 | -0.2 |
| 5 | 4960.00 | 48.0 PK | 74.0 | -26.0 | 3.17 V | 187 | 40.0 | 8.0 |
| 6 | 4960.00 | 36.5 AV | 54.0 | -17.5 | 3.17 V | 187 | 28.5 | 8.0 |

Remarks:

1. Emission Level(dBuV/m) = Raw Value(dBuV) + Correction Factor(dB/m)
2. Correction Factor(dB/m) = Antenna Factor(dB/m) + Cable Factor(dB) – Pre-Amplifier Factor(dB)
3. Margin value = Emission Level – Limit value
4. The other emission levels were very low against the limit.
5. " * ": Fundamental frequency, the limit was restricted at the RF Output Power.

A(Right Earphone)_Plot of Band Edge

| | | | |
|-----------------|--------------------|-------------------------------|--|
| Frequency Range | 2.31 GHz ~ 2.5 GHz | Detector Function & Bandwidth | PK: RB=1 MHz, VB=3 MHz, DET=Peak AV: RB=1 MHz, VB=3 kHz, DET=Peak |
|-----------------|--------------------|-------------------------------|--|

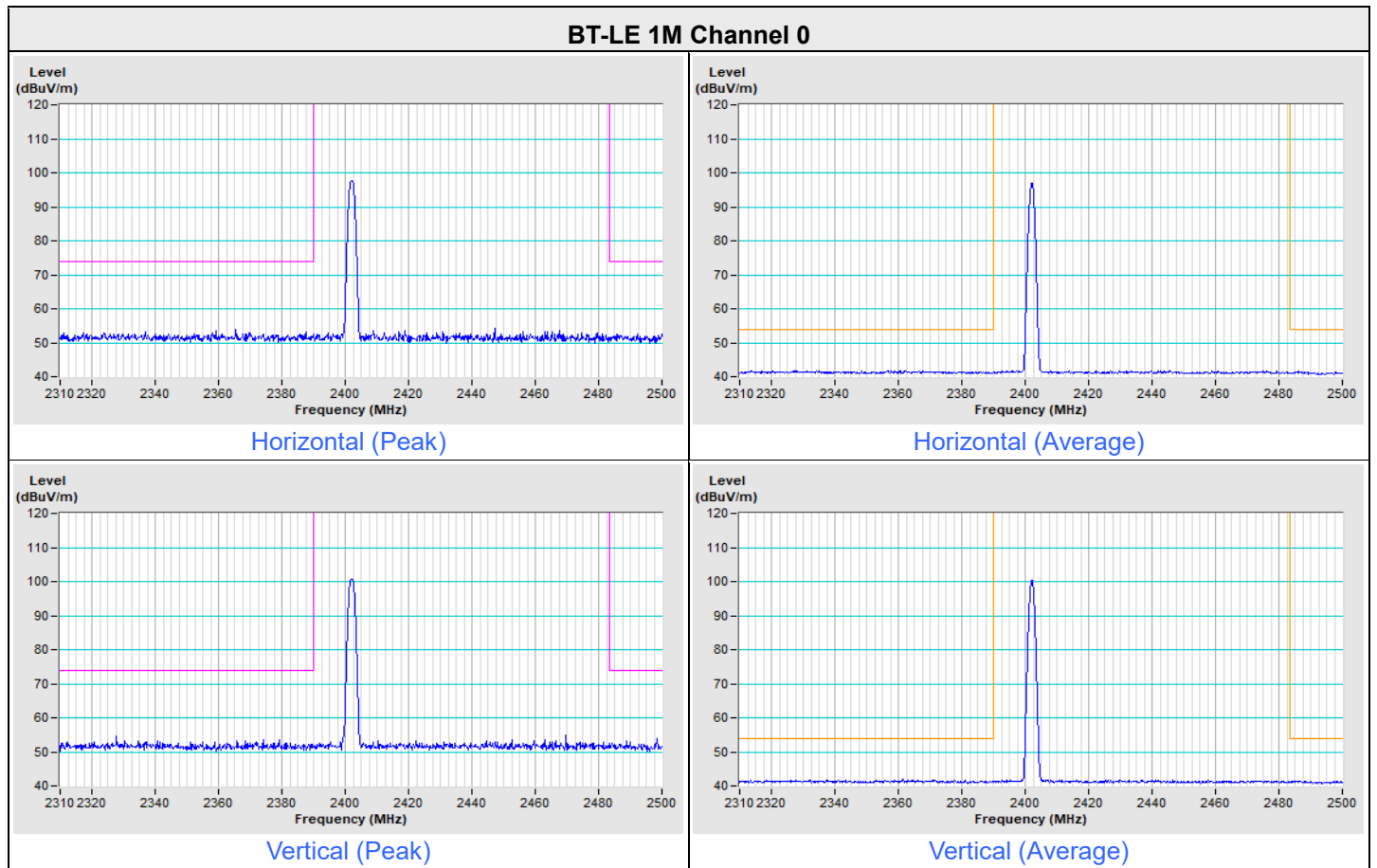

BT-LE 1M Channel 39

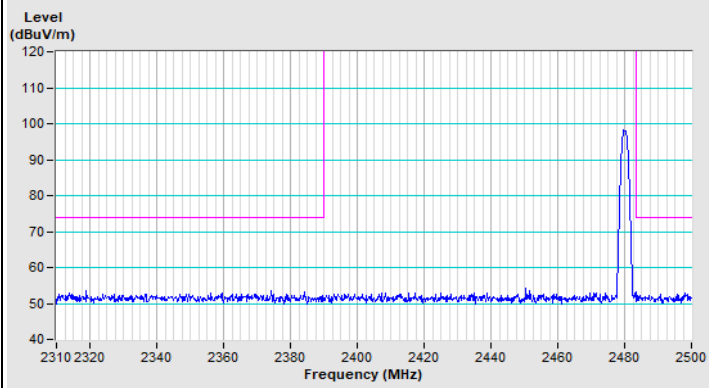

Horizontal (Peak)

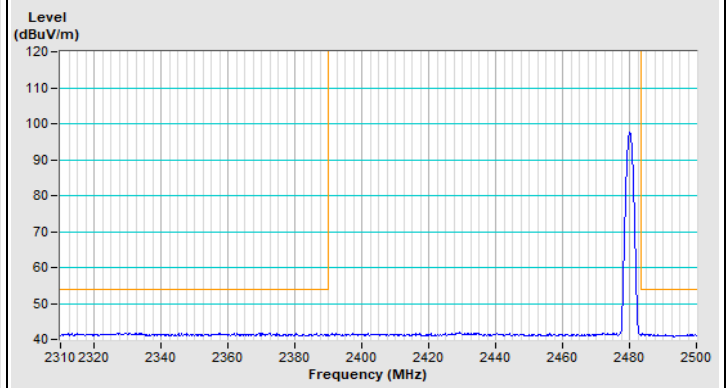

Horizontal (Average)

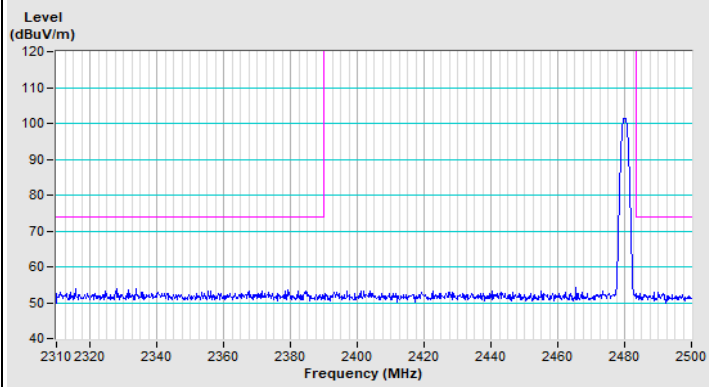

Vertical (Peak)

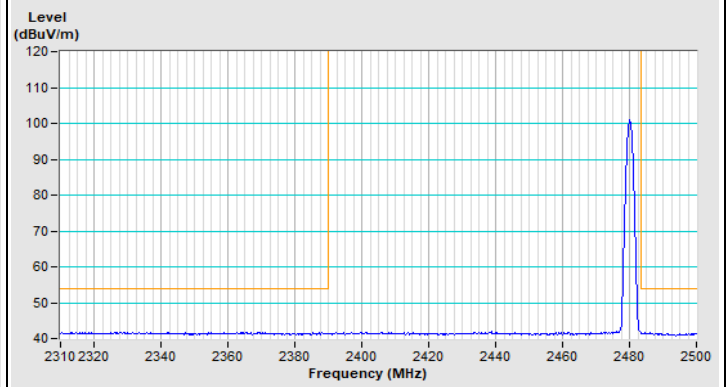

Vertical (Average)



| | | | |
|-----------------|--------------------|-------------------------------|--|
| Frequency Range | 2.31 GHz ~ 2.5 GHz | Detector Function & Bandwidth | PK: RB=1 MHz, VB=3 MHz, DET=Peak AV: RB=1 MHz, VB=1 kHz, DET=Peak |
|-----------------|--------------------|-------------------------------|--|

BT-LE 2M Channel 0

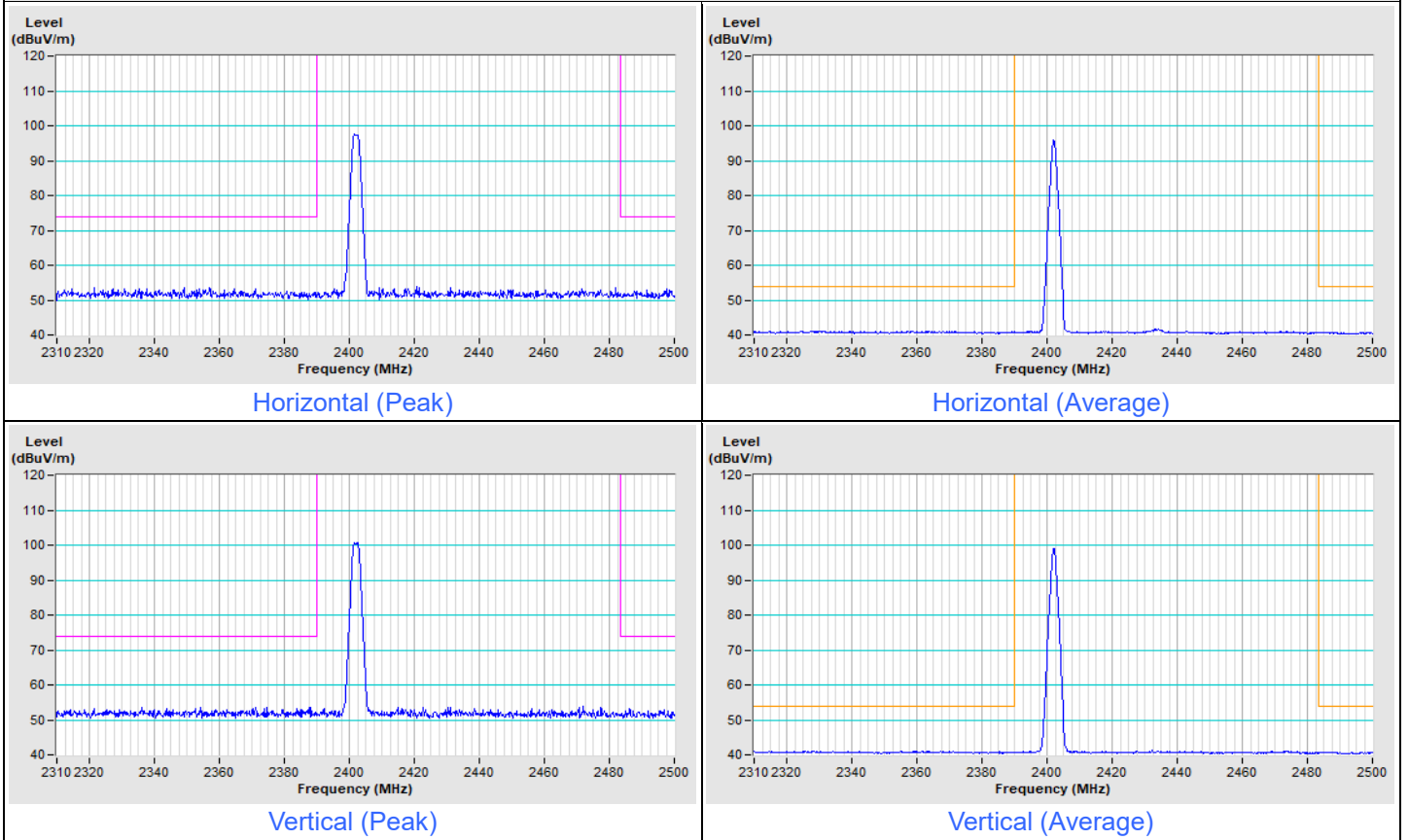

BT-LE 2M Channel 39

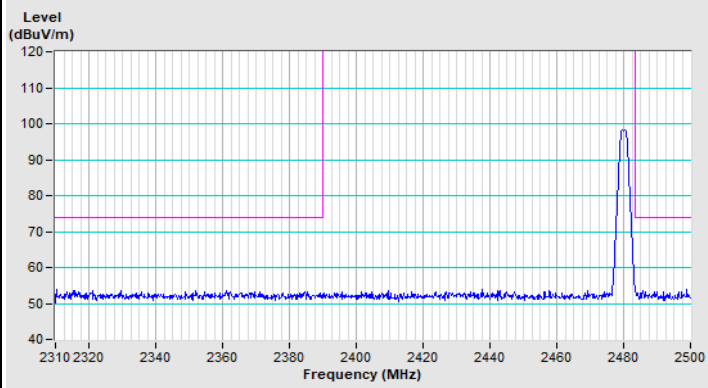

Horizontal (Peak)

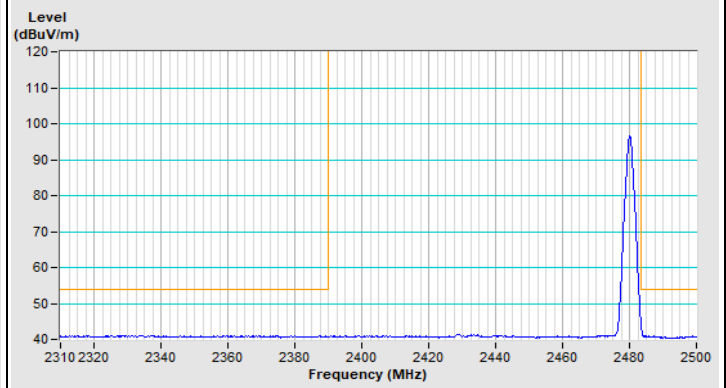

Horizontal (Average)

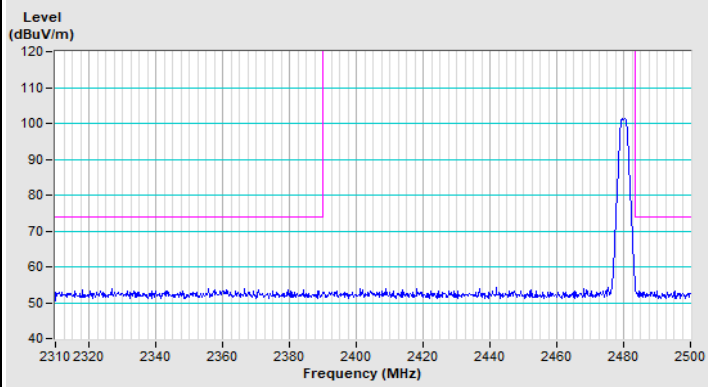

Vertical (Peak)

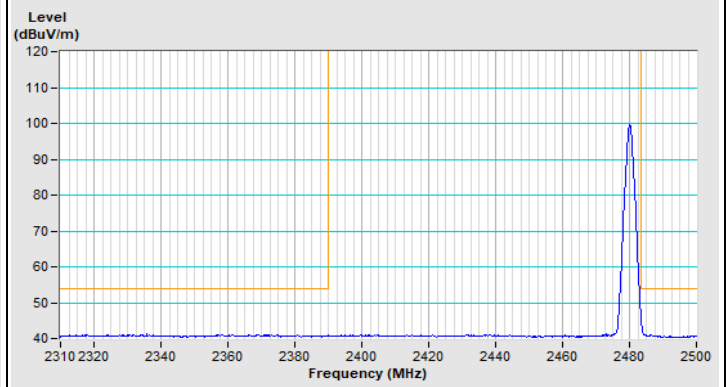

Vertical (Average)

8 Pictures of Test Arrangements

Please refer to the attached file (Test Setup Photo)

9 Information of the Testing Laboratories

We, Bureau Veritas Consumer Products Services (H.K.) Ltd., Taoyuan Branch, were founded in 1988 to provide our best service in EMC, Radio, Telecom and Safety consultation. Our laboratories are FCC recognized accredited test firms and accredited according to ISO/IEC 17025.

If you have any comments, please feel free to contact us at the following:

Lin Kou EMC/RF Lab

Tel: 886-2-26052180

Fax: 886-2-26051924

Hsin Chu EMC/RF/Telecom Lab

Tel: 886-3-6668565

Fax: 886-3-6668323

Hwa Ya EMC/RF/Safety Lab

Tel: 886-3-3183232

Fax: 886-3-3270892

Email: service.adt@bureauveritas.com

Web Site: <http://ee.bureauveritas.com.tw>

The address and road map of all our labs can be found in our web site also.

--- END ---