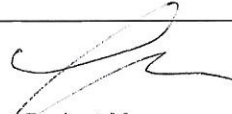

Prüfbericht-Nr.: <i>Test Report No.:</i>	10043355 001	Auftrags-Nr.: <i>Order No.:</i>	114010406	Seite 1 von 44 <i>Page 1 of 44</i>
Kunden-Referenz-Nr.: <i>Client Reference No.:</i>	N/A	Auftragsdatum: <i>Order date:</i>	May 29, 2013	
Auftraggeber: <i>Client:</i>	ISSC Technologies Corp., No.5, Industry E. Rd. VII, Hsinchu Science Park, Hsinchu 30077, Taiwan, R.O.C.			
Prüfgegenstand: <i>Test item:</i>	Bluetooth Shielded Module			
Bezeichnung / Typ-Nr.: <i>Identification / Type No.:</i>	BM87SPPS5, BM87SPPS3, BM88SPKS3, BM81SPKS3			
Auftrags-Inhalt: <i>Order content:</i>	FCC Part 15C Test report			
Prüfgrundlage: <i>Test specification:</i>	FCC 47CFR Part 15: Subpart C Section 15.247			
Wareneingangsdatum: <i>Date of receipt:</i>	07/22/2013			
Prüfmuster-Nr.: <i>Test sample No.:</i>	A000018491-001 A000018491-002			
Prüfzeitraum: <i>Testing period:</i>	31-Jul-2013 - 4-Sep-2013			
Ort der Prüfung: <i>Place of testing:</i>	EMC Laboratory Taipei			
Prüflaboratorium: <i>Testing laboratory:</i>	TUV Rheinland Taiwan Ltd.			
Prüfergebnis*: <i>Test result*:</i>	Pass			
geprüft von / tested by:		kontrolliert von / reviewed by:		
				
2013-09-05 Danny S. C. Sung/ Project Manager		2013-09-05 Rene Charton/Senior Project Manager		
Datum <i>Date</i>	Name / Stellung <i>Name / Position</i>	Unterschrift <i>Signature</i>	Datum <i>Date</i>	Name / Stellung <i>Name / Position</i>
				Unterschrift <i>Signature</i>
Sonstiges / Other:				
Zustand des Prüfgegenstandes bei Anlieferung: <i>Condition of the test item at delivery:</i>		Prüfmuster vollständig und unbeschädigt <i>Test item complete and undamaged</i>		
* Legende:	1 = sehr gut P(ass) = entspricht o.g. Prüfgrundlage(n)	2 = gut F(all) = entspricht nicht o.g. Prüfgrundlage(n)	3 = befriedigend N/A = nicht anwendbar	4 = ausreichend N/T = nicht getestet
Legend:	1 = very good P(ass) = passed a.m. test specification(s)	2 = good F(ail) = failed a.m. test specification(s)	3 = satisfactory N/A = not applicable	4 = sufficient N/T = not tested
Dieser Prüfbericht bezieht sich nur auf das o.g. Prüfmuster und darf ohne Genehmigung der Prüfstelle nicht auszugsweise vervielfältigt werden. Dieser Bericht berechtigt nicht zur Verwendung eines Prüfzeichens. <i>This test report only relates to the a. m. test sample. Without permission of the test center this test report is not permitted to be duplicated in extracts. This test report does not entitle to carry any test mark.</i>				

104

TEST SUMMARY

5.1.1 ANTENNA REQUIREMENT

RESULT: *Passed*

5.1.2 PEAK OUTPUT POWER

RESULT: *Passed*

5.1.3 20dB BANDWIDTH

RESULT: *Passed*

5.1.4 99% BANDWIDTH

RESULT: *Passed*

5.1.5 CONDUCTED SPURIOUS EMISSIONS AND FREQUENCY BAND EDGE MEASURED IN 100KHz BANDWIDTH

RESULT: *Passed*

5.1.6 SPURIOUS EMISSION

RESULT: *Passed*

5.1.7 FREQUENCY SEPARATION

RESULT: *Passed*

5.1.8 NUMBER OF HOPPING FREQUENCY

RESULT: *Passed*

5.1.9 TIME OF OCCUPANCY

RESULT: *Passed*

5.2.1 MAINS CONDUCTED EMISSIONS

RESULT: *Passed*

6.1.1 ELECTROMAGNETIC FIELDS

RESULT: *Passed*

Contents

1.	GENERAL REMARKS	5
1.1	COMPLEMENTARY MATERIALS.....	5
2.	TEST SITES	6
2.1	TEST FACILITIES.....	6
2.2	LIST OF TEST AND MEASUREMENT INSTRUMENTS.....	6
2.3	TRACEABILITY	7
2.4	CALIBRATION	7
2.5	MEASUREMENT UNCERTAINTY	7
3.	GENERAL PRODUCT INFORMATION.....	8
3.1	PRODUCT FUNCTION AND INTENDED USE	8
3.2	SYSTEM DETAILS AND RATINGS.....	8
3.3	INDEPENDENT OPERATION MODES.....	9
3.4	NOISE GENERATING AND NOISE SUPPRESSING PARTS	10
3.5	SUBMITTED DOCUMENTS.....	10
4.	TEST SET-UP AND OPERATION MODES.....	11
4.1	PRINCIPLE OF CONFIGURATION SELECTION	11
4.2	TEST OPERATION AND TEST SOFTWARE.....	11
4.3	SPECIAL ACCESSORIES AND AUXILIARY EQUIPMENT	11
4.4	COUNTERMEASURES TO ACHIEVE EMC COMPLIANCE.....	12
4.5	TEST SETUP DIAGRAM	12
5.	TEST RESULTS	14
5.1	TRANSMITTER REQUIREMENT & TEST SUITES	14
<i>5.1.1</i>	<i>Antenna Requirement</i>	<i>14</i>
<i>5.1.2</i>	<i>Peak Output Power.....</i>	<i>15</i>
<i>5.1.3</i>	<i>20dB Bandwidth</i>	<i>19</i>
<i>5.1.4</i>	<i>99% Bandwidth</i>	<i>23</i>
<i>5.1.5</i>	<i>Conducted spurious emissions and Frequency Band Edge measured in 100kHz Bandwidth.....</i>	<i>27</i>
<i>5.1.6</i>	<i>Spurious Emission</i>	<i>33</i>
<i>5.1.7</i>	<i>Frequency Separation.....</i>	<i>34</i>
<i>5.1.8</i>	<i>Number of hopping frequency.....</i>	<i>36</i>
<i>5.1.9</i>	<i>Time of Occupancy</i>	<i>38</i>
6.	SAFETY HUMAN EXPOSURE	41
6.1	RADIO FREQUENCY EXPOSURE COMPLIANCE	41
<i>6.1.1</i>	<i>Electromagnetic Fields.....</i>	<i>41</i>

Prüfbericht - Nr.: 10043355 001
Test Report No.

Seite 4 von 44
Page 4 of 44

7.	PHOTOGRAPHS OF THE TEST SET-UP.....	42
8.	LIST OF TABLES	44
9.	LIST OF PHOTOGRAPHS.....	44

1. General Remarks

1.1 Complementary Materials

All attachments are integral parts of this test report. This applies especially to the following appendix:

Appendix P: Photo Documentation

(File Name: 10043355APPENDIX P)

Appendix D: Test Result of Radiated Emissions

(File Name: 10043355APPENDIX D)

Test Specifications

The following standards were applied (in bold: product standards, otherwise: basic standards).

Table 1: Applied Standard and Test Levels

Radio
FCC CFR47 Part 15: Subpart C Section 15.247
ANSI C63.4:2009, Public Notice DA 00-705

2. Test Sites

2.1 Test Facilities

TUV Rheinland Taiwan Ltd.

11F. No.758, Sec. 4, Bade Rd., Songshan Dist.
 Taipei City 105
 Taiwan (R.O.C.)
 FCC Registration No.: 365730

2.2 List of Test and Measurement Instruments

Table 2: List of Test and Measurement Equipment

	Manufacturer	Type	S/N	Calibrated until
EMI Test Receiver	R&S	ESCI 7	1166.5950K07-100797-Pt	20-Dec-13
Bilog Antenna	TESEQ	CBL6111D	29802	29-Jun-14
Pre-Amplifier	HP	8447F	2805A03335	14-Sep-13
Spectrum Analyzer	R&S	FSV 40	100921	13-Dec-13
Horn Antenna (1GHz~18GHz)	COM-POWER	AHA118	701251	28-Sep-13
Horn Antenna (18GHz~40GHz)	COM-POWER	AH840	101031	2-Nov-13
Preamplifier (30MHz -1GHz)	HP	8447F	2805A03335	14-Sep-13
Preamplifier (18 GHz -40 GHz)	COMPOWER	PAM-840	461257	17-Sep-13
Loop Antenna	Schwarzbeck	FMZB 1513	1513-076	28-Sep-13
Power meter	R&S	NRVD	100439	17-Apr-14
Power sensor	R&S	NRV-Z1	100013	17-Apr-14

2.3 Traceability

All measurement equipment calibrations are traceable to NML(Taiwan)/NIST(USA) or where calibration is performed outside Taiwan, to equivalent nationally recognized standards organizations.

2.4 Calibration

Equipment requiring calibration is calibrated periodically by the manufacturer or according to manufacturer's specifications. Additionally all equipment is verified for proper performance on a regular basis using in house standards or comparisons.

2.5 Measurement Uncertainty

The estimated combined standard uncertainty for radiated emissions and conducted emissions measurements are ± 3 dB.

Table 3: Emission Measurement Uncertainty

Parameter	Uncertainty
Radio Frequency	$\pm 1 \times 10^{-7}$
RF power, conducted	± 1 dB
Adjacent channel power	± 3 dB
Radiated emission of transmitter, valid up to 26 GHz	± 6 dB
Radiated emission of receiver, valid up to 26 GHz	± 6 dB
Temperature	± 2 °C
Humidity	± 10 %

3. General Product Information

3.1 Product Function and Intended Use

This test report is for a series of Bluetooth modules. All modules use an RF IC with the same SoC chip crystal. The difference is in digital device portions of the SOC, by disabling certain functions (MFi and SPP) All 4 Chips have the same pin layout. The version tested is BM87SPPS5
For details refer to the User Guide, Data Sheet and Circuit Diagram.

3.2 System Details and Ratings

Table 4: Basic Information of EUT

Item	EUT information
Kind of Equipment	Bluetooth Shielded Module
Type Designation	BM87SPPS5, BM87SPPS3, BM88SPKS3, BM81SPKS3
FCC ID	A8T-BM87SPPS5

Table 5: Technical Specification of EUT

Technical Specification	Value
Operating Frequency	2402 MHz ~ 2480 MHz
Channel Spacing	1 MHz
Channel number	79
Operation Voltage	3.8 V
Modulation	GFSK, $\pi/4$ QPSK, 8 DPSK
Antenna gain	0.9 dBi

Table 6: Frequency hopping information

Technical Specification	Description
Hopping Range	Hereby we declare that the maximum frequency of this device is: 2402-2480MHz. This is according the Bluetooth Core Specification V2.1+EDR for devices which will be operated in the USA. This was checked during the Bluetooth Qualification tests (Test Case: TRM/CA/04).
Hopping Sequence	Example of a 79 hopping sequence in data mode: 33,04,21,44,23,42,53,46,55,48,40,59,72,29,76,31,08,73,07,75,09,45,60,39,58,13,47,11,77,52,35,50,65,54,67,56,69,62,71,64, 7,25,27,66,57,70,74,61,78,63,10,41,05,43,15,44,64,68,02,70,06,01,51,03,55,05,03,66,53,49,36,47,
Receiver input bandwidth	<p>The input bandwidth of the receiver is 1MHz. In every connection one Bluetooth device is the master and the other one is the slave. The master determines the hopping sequence. The slave follows this sequence. Both devices shift between RX and TX time slot according to the clock of the master.</p> <p>Additionally the type of connection is set up at the beginning of the connection. The master adapts its hopping frequency and its TX/RX timing according to the packet type of the connection. Also the slave of the connection will use these settings.</p> <p>Repeating of a packer has no influence on the hopping sequence. The hopping sequence generated by the master of the connection will be followed in any case.</p> <p>That means a repeated packet will not be send on the same frequency, it is send on the next frequency of the hopping sequence.</p>

3.3 Independent Operation Modes

The basic operation modes are:

- A. Transmitting
 - 1. Low channel
 - 2. Middle channel
 - 3. High channel
- B. Receiving
- C. Standby
- D. Off

3.4 Noise Generating and Noise Suppressing Parts

Refer to the Circuit Diagram.

3.5 Submitted Documents

- Bill of Material
- PCB Layout
- Photo Document
- Technical Description
- Circuit Diagram
- Instruction Manual
- Rating Label

4. Test Set-up and Operation Modes

4.1 Principle of Configuration Selection

The equipment under test (EUT) was configured to measure its maximum power level. The test modes were adapted accordingly in reference to the instructions for use.

4.2 Test Operation and Test Software

Test operation refers to test setup in chapter 4. All testing were performed according to the procedures in ANSI C63.10: 2009 and DA 00-705 of March 30, 2000.

The samples were used as follows:

Conducted: A000018491-002

Radiation: A000018491-001

Full test was applied on all test modes, but only worst case was shown.

4.3 Special Accessories and Auxiliary Equipment

The product has been tested together with the following additional accessories:

Kind of Equipment	Manufacturer	Model Name	S/N
Laptop	MSI	MSI4532 (CX420MX)	CX420 MX-233TWK 1008000096

4.4 Countermeasures to achieve EMC Compliance

The test sample which has been tested contained the noise suppression parts as described in the Constructional Data Form or the Technical Construction File. No additional measures were employed to achieve compliance.

4.5 Test Setup Diagram

Diagram of Measurement Configuration for Radiation Test

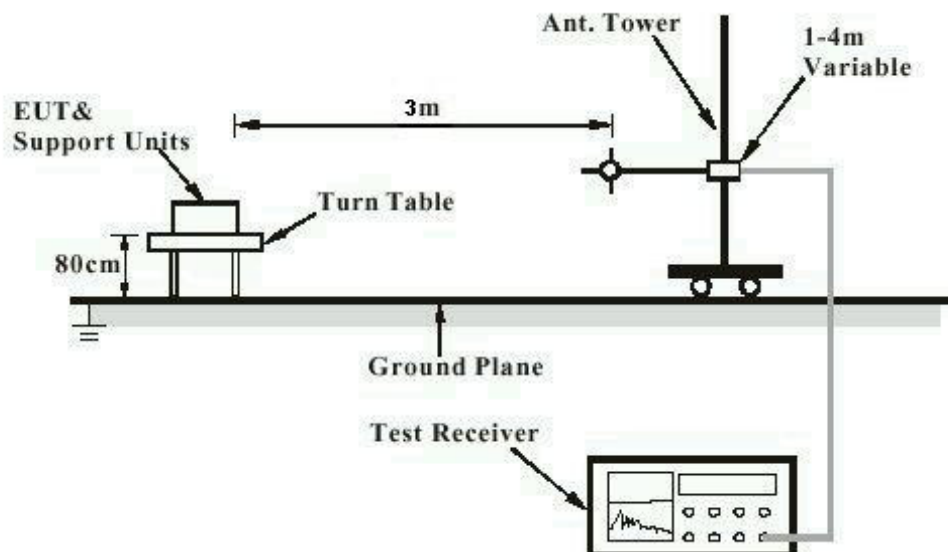

Diagram of Measurement Equipment Configuration for Mains Conduction Measurement

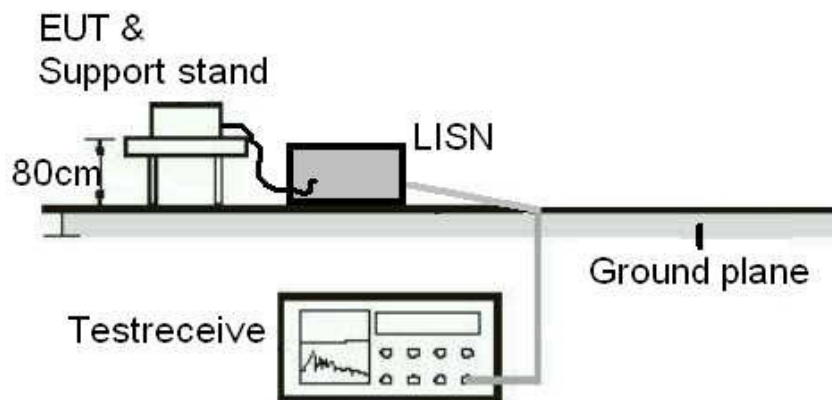
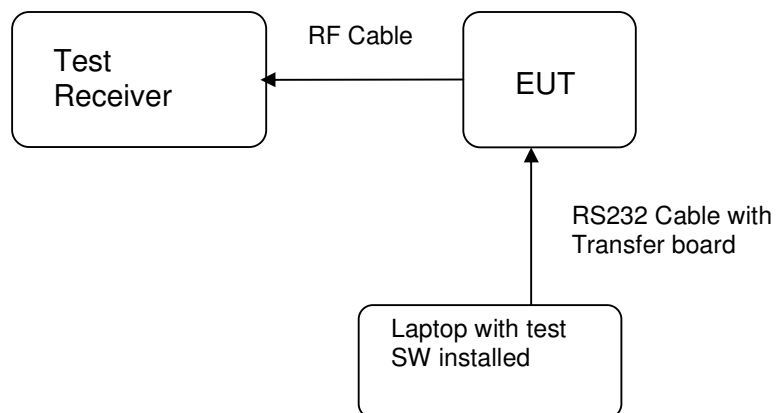

Diagram of Measurement Equipment Configuration for Conducted Transmitter Measurement



5. Test Results

5.1 Transmitter Requirement & Test Suites

5.1.1 Antenna Requirement

RESULT: **Passed**

Test standard	:	FCC Part 15.247(b)(4), Part 15.203 and RSS-Gen 7.1.4
Limit	:	the use of antennas with directional gains that do not exceed 6 dBi

According to the manufacturer declaration, the EUT has an antenna with a directional gain of 0.9 dBi. The antenna is a printed PCB trace with no possibility of replacement by the end-user. Therefore, the EUT is considered to comply with this provision.

.

Refer to EUT photo for details.

5.1.2 Peak Output Power

RESULT:
Passed

Test standard : FCC Part 15.247(b)(1), RSS-210 A8.4(2)
 Basic standard : DA 00-705 of March 30, 2000
 Kind of test site : Shielded room

Test setup

Test Channel : Low/ Middle/ High
 Operation Mode : A

 Ambient temperature : 22-26 °C
 Relative humidity : 50-65 %
 Atmospheric pressure : 100-103 kPa

Table 7: Test result of Peak Output Power, GFSK modulation

Channel	Channel Frequency	Peak Output Power		Limit
	(MHz)	(dBm)	(W)	(W)
Low Channel	2402	0.79	0.0012	0.125
Middle Channel	2441	0.90	0.0012	0.125
High Channel	2480	1.26	0.0013	0.125

Table 8: Test result of Peak Output Power, 8DPSK modulation

Channel	Channel Frequency	Peak Output Power		Limit
	(MHz)	(dBm)	(W)	(W)
Low Channel	2402	0.53	0.0011	0.125
Middle Channel	2441	0.60	0.0011	0.125
High Channel	2480	1.01	0.0013	0.125

Pmax: 1.3 mW

Test Plot of Peak Output Power, GFSK modulation

Low Channel

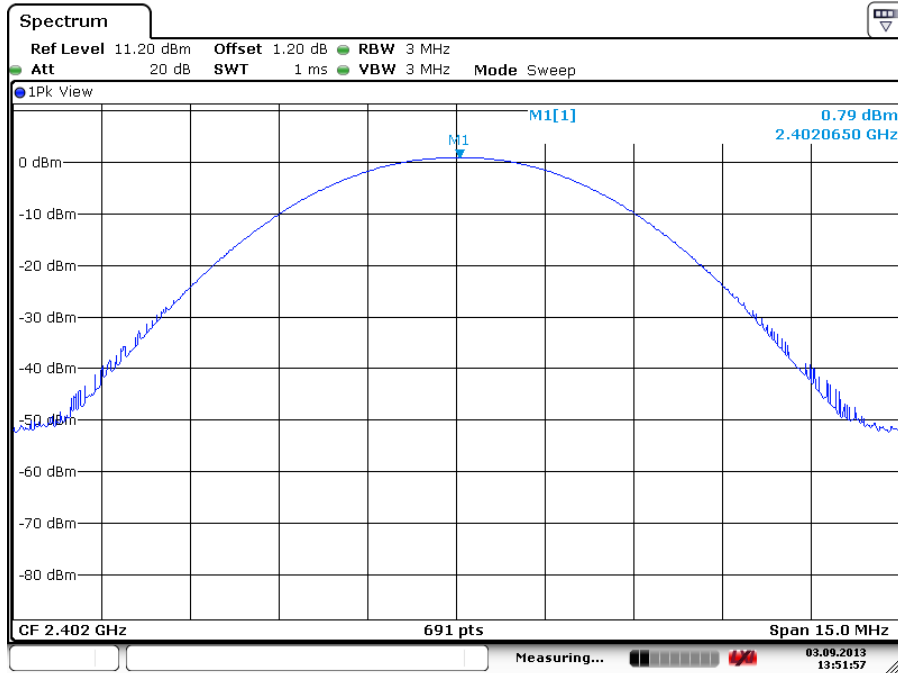

Middle Channel

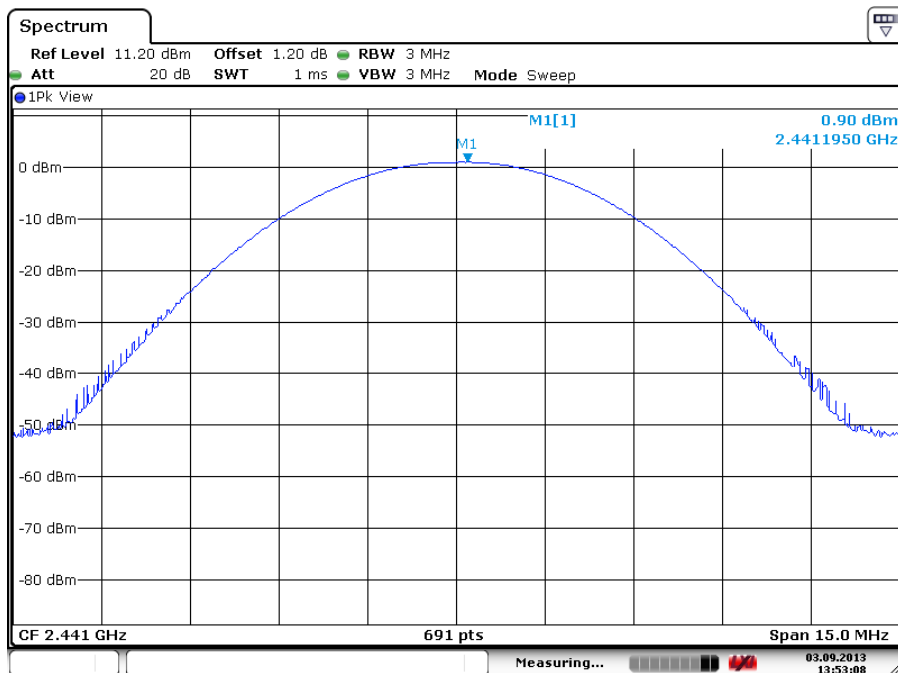

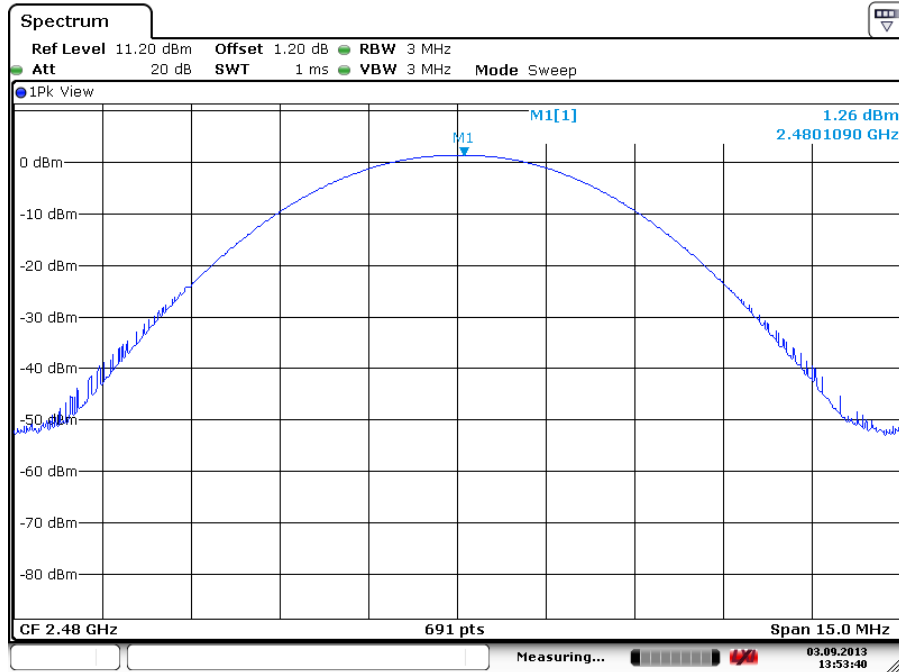
High Channel

Date: 3.SEP.2013 13:53:40

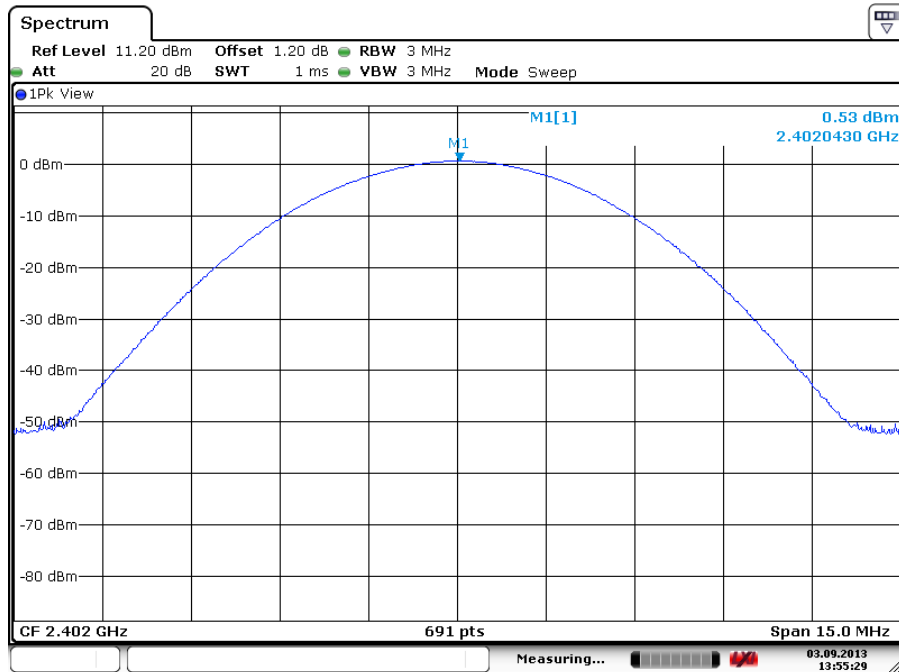
Test Plot of Peak Output Power, 8DPSK modulation
Low Channel

Date: 3.SEP.2013 13:55:29

Middle Channel

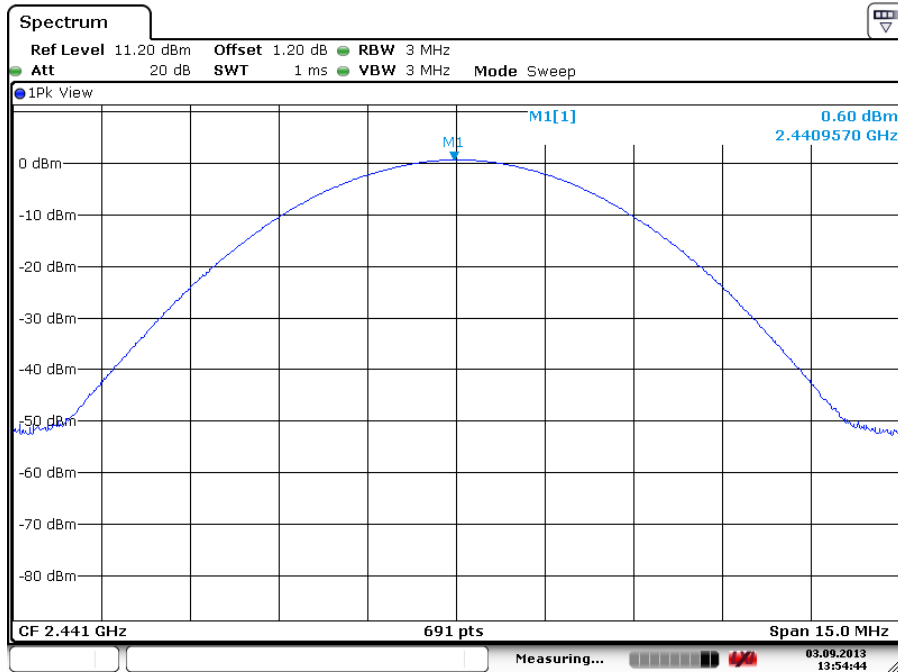

Date: 3.SEP.2013 13:54:44

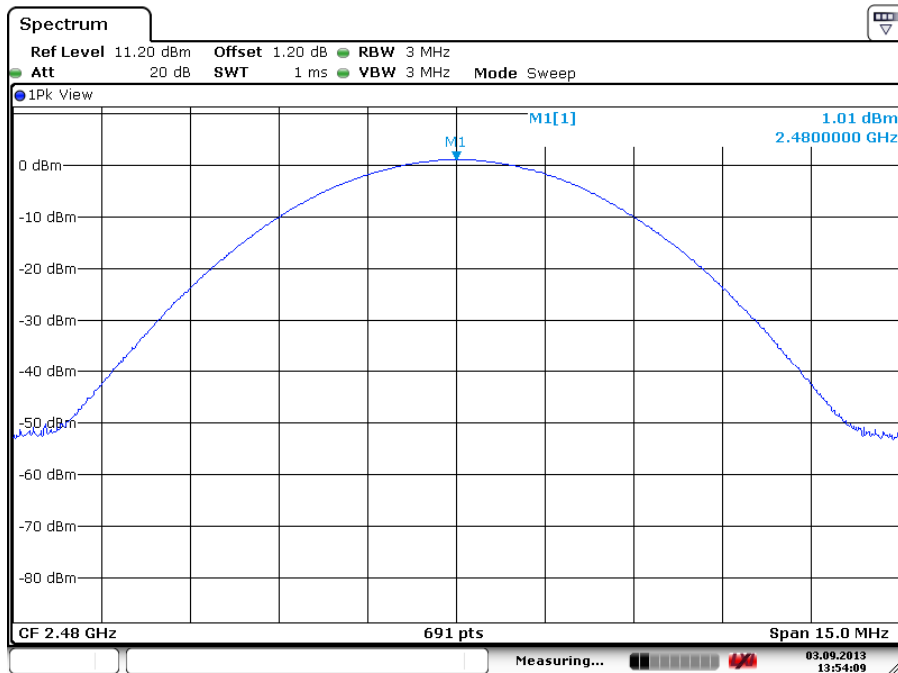
High Channel

Date: 3.SEP.2013 13:54:09

5.1.3 20dB Bandwidth

RESULT:
Passed

Test standard : FCC Part 15.247(a)(1), RSS-210 A8.1(a)
 Basic standard : DA 00-705 of March 30, 2000
 Kind of test site : Shielded room

Test setup

Test Channel : Low/ Middle/ High
 Operation Mode : A

 Ambient temperature : 22-26°C
 Relative humidity : 50-65%
 Atmospheric pressure : 100-103 kPa

Table 9: Test result of 20dB Bandwidth, GFSK modulation

Channel	Channel Frequency (MHz)	20dB Bandwidth (kHz)	Limit (MHz)	Result
Low Channel	2402	937.8	1.5	Pass
Mid Channel	2441	942.1	1.5	Pass
High Channel	2480	933.4	1.5	Pass

Note: Limit is for Channel Separation of 1 MHz and a power limit of 125 mW.

Table 10: Test result of 20dB Bandwidth, 8DPSK modulation

Channel	Channel Frequency (MHz)	20dB Bandwidth (kHz)	Limit (MHz)	Result
Low Channel	2402	1254.7	1.5	Pass
Mid Channel	2441	1254.7	1.5	Pass
High Channel	2480	1254.7	1.5	Pass

Note: Limit is for Channel Separation of 1 MHz and a power limit of 125 mW.

Test Plot of 20dB Bandwidth, GFSK modulation

Low Channel

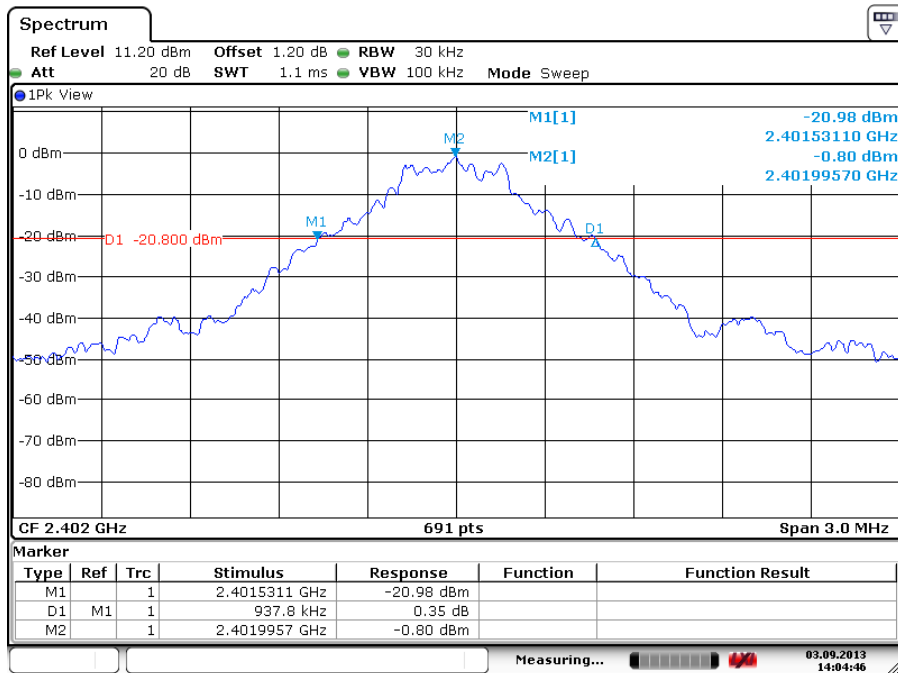

Date: 3.SEP.2013 14:04:46

Middle Channel

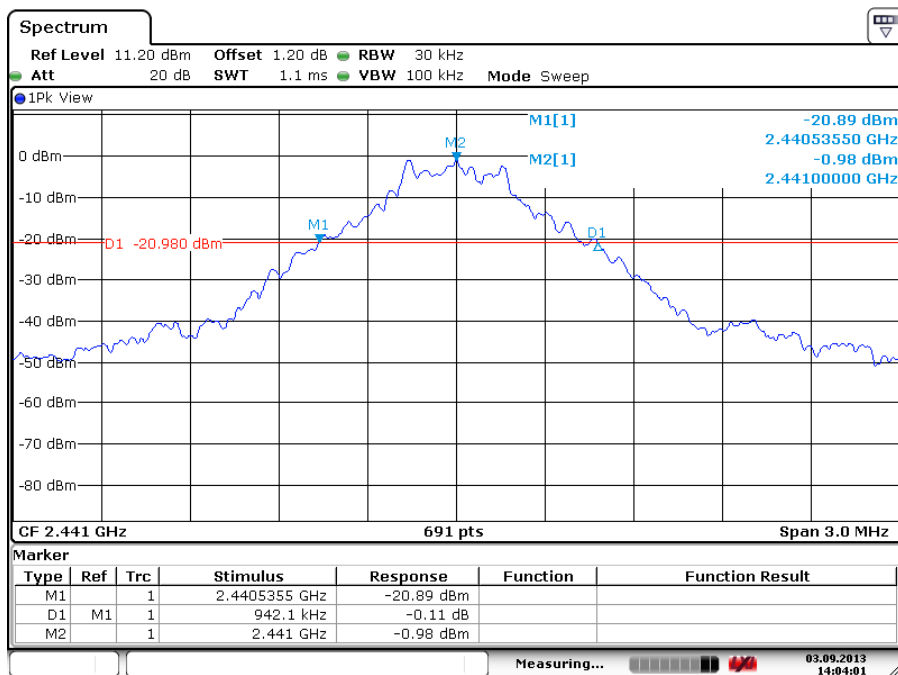

Date: 3.SEP.2013 14:04:01

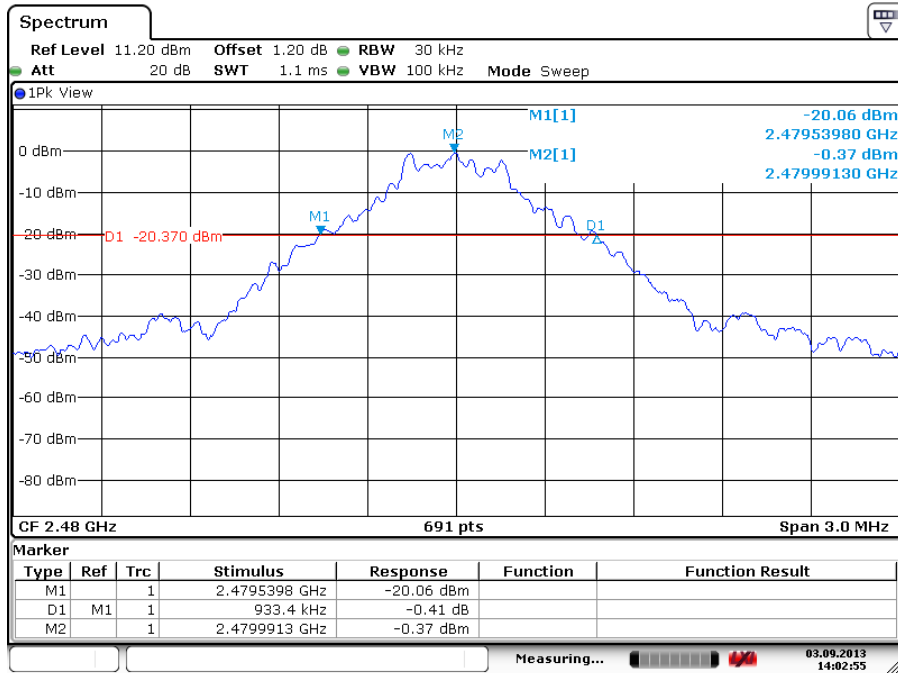
High Channel

Date: 3.SEP.2013 14:02:55

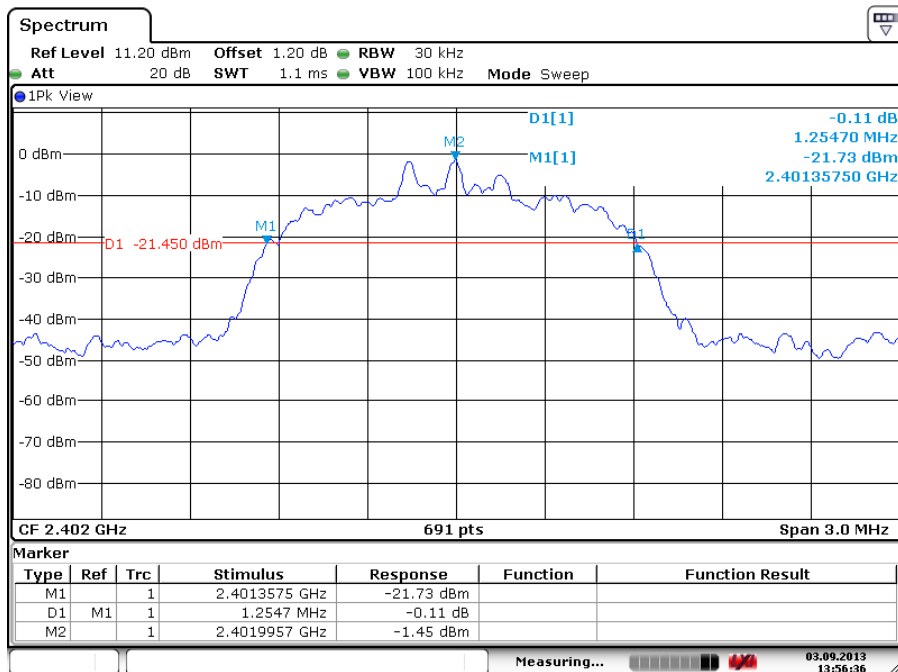
Test Plot of 20dB Bandwidth, 8DPSK modulation
Low Channel

Date: 3.SEP.2013 13:56:36

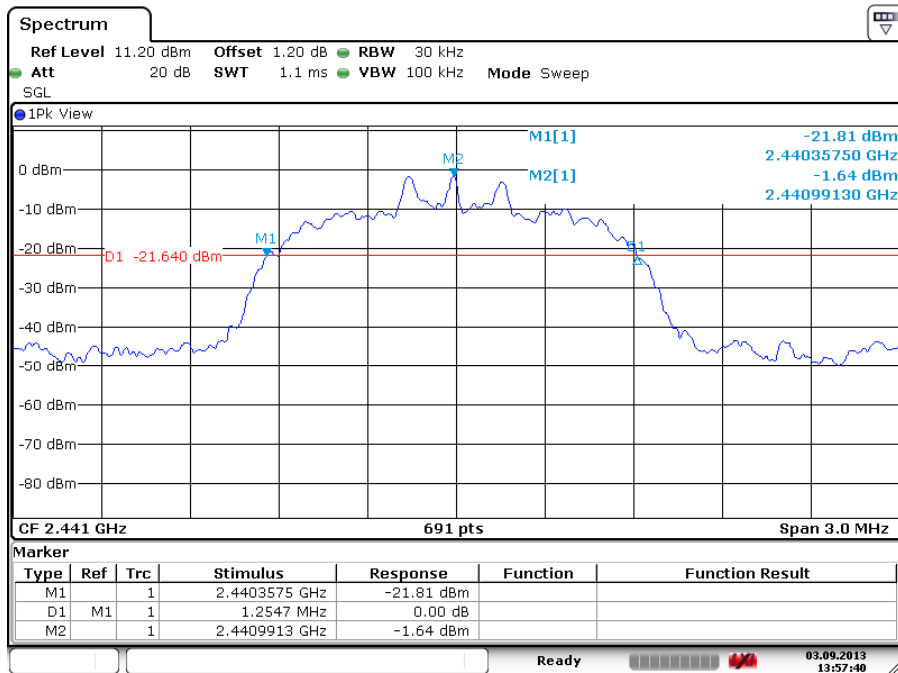
Middle Channel

Date: 3.SEP.2013 13:57:40

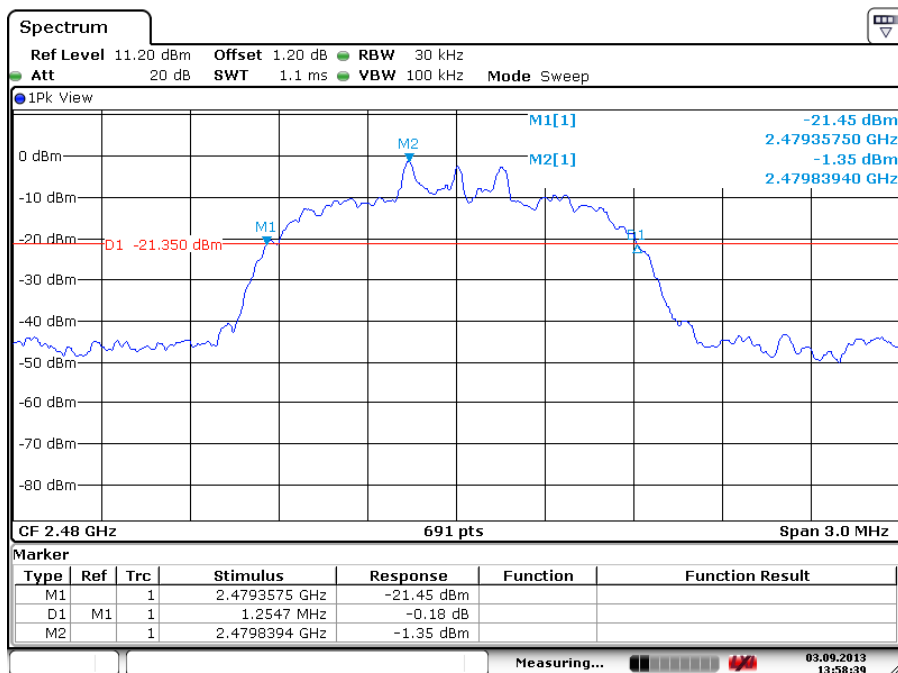
High Channel

Date: 3.SEP.2013 13:58:38

5.1.4 99% Bandwidth

RESULT:
Passed

Test standard : RSS-Gen (Issue 3) Dec. 2010
 Basic standard : RSS-Gen (Issue 3) Dec. 2010
 Kind of test site : Shielded room

Test setup

Test Channel : Low/ Middle/ High
 Operation Mode : A

 Ambient temperature : 22-26°C
 Relative humidity : 50-65%
 Atmospheric pressure : 100-103 kPa

Table 11: Test result of 99% Bandwidth, GFSK modulation

Channel	Channel Frequency (MHz)	99% Bandwidth (kHz)	Low Limit (MHz)	Result
Low Channel	2402	863	/	Pass
Mid Channel	2441	872	/	Pass
High Channel	2480	868	/	Pass

Table 12: Test result of 99% Bandwidth, PSK modulation

Channel	Channel Frequency (MHz)	99% Bandwidth (kHz)	Low Limit (MHz)	Result
Low Channel	2402	1163	/	Pass
Mid Channel	2441	1154	/	Pass
High Channel	2480	1159	/	Pass

Test Plot of 99% Bandwidth, GFSK modulation

Low Channel

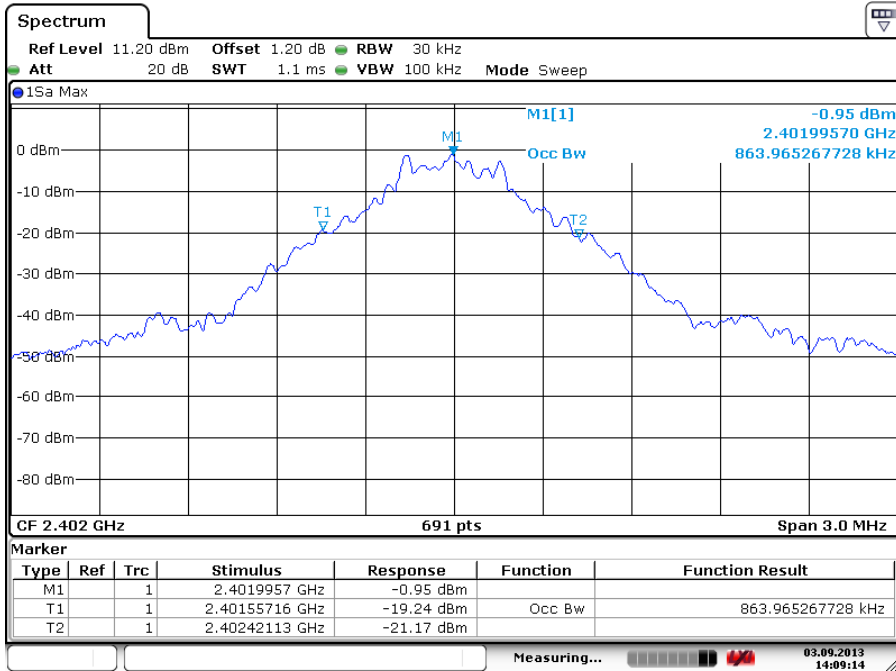

Date: 3.SEP.2013 14:09:14

Middle Channel

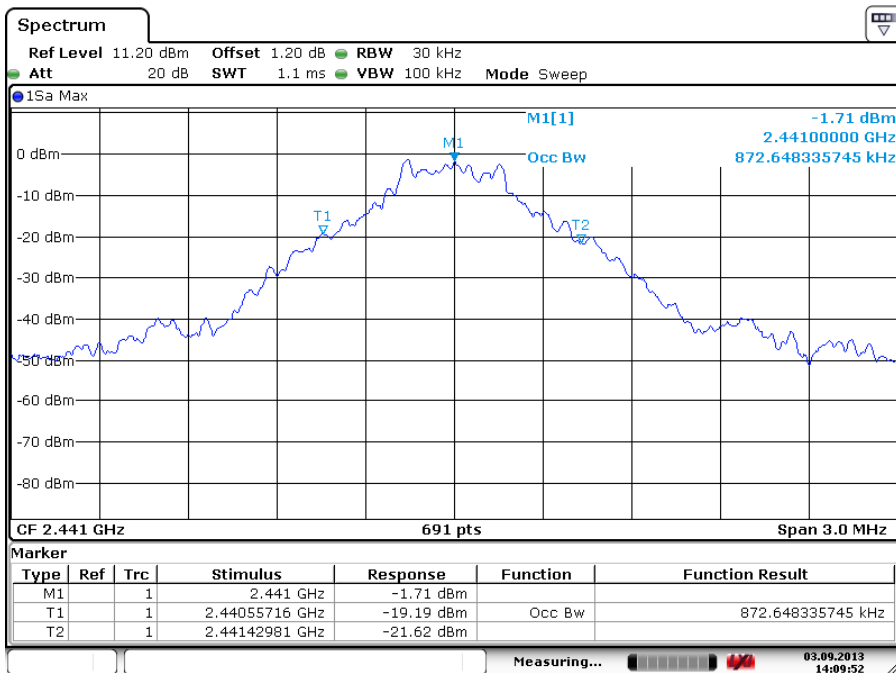

Date: 3.SEP.2013 14:09:52

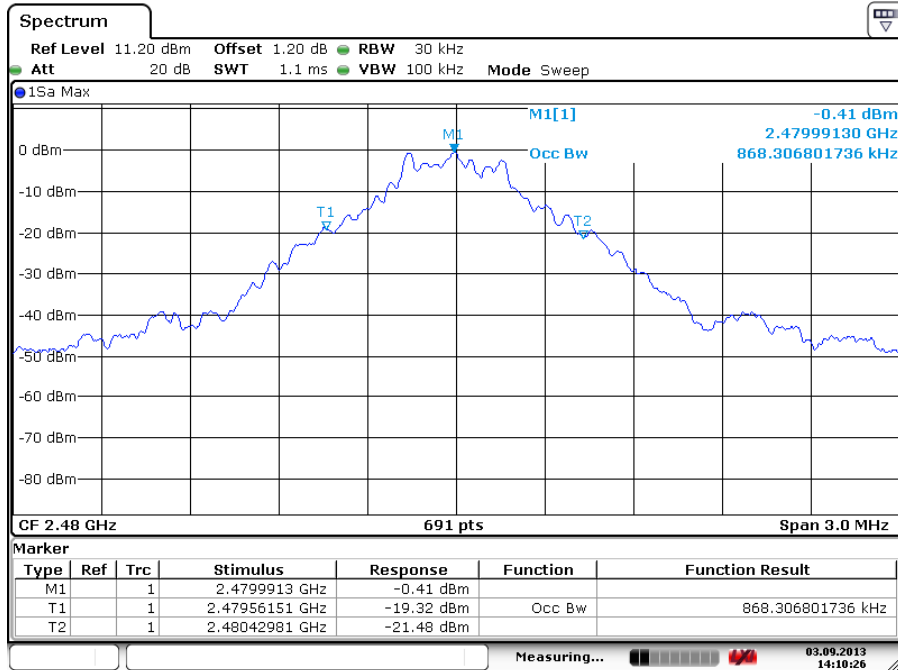
High Channel

Date: 3.SEP.2013 14:10:26

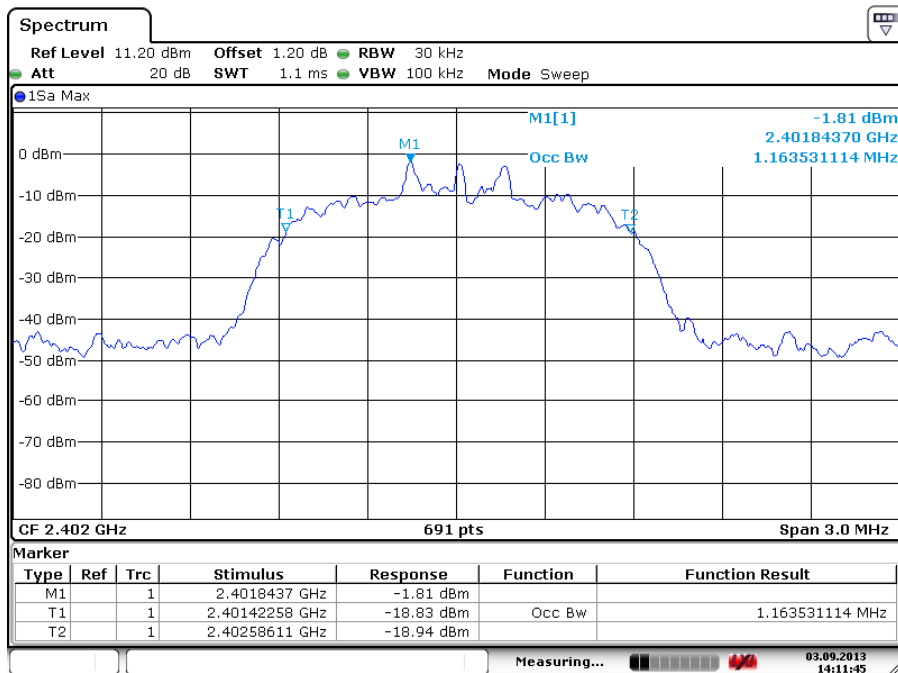
Test Plot of 99% Bandwidth, 8DPSK modulation
Low Channel

Date: 3.SEP.2013 14:11:45

Middle Channel

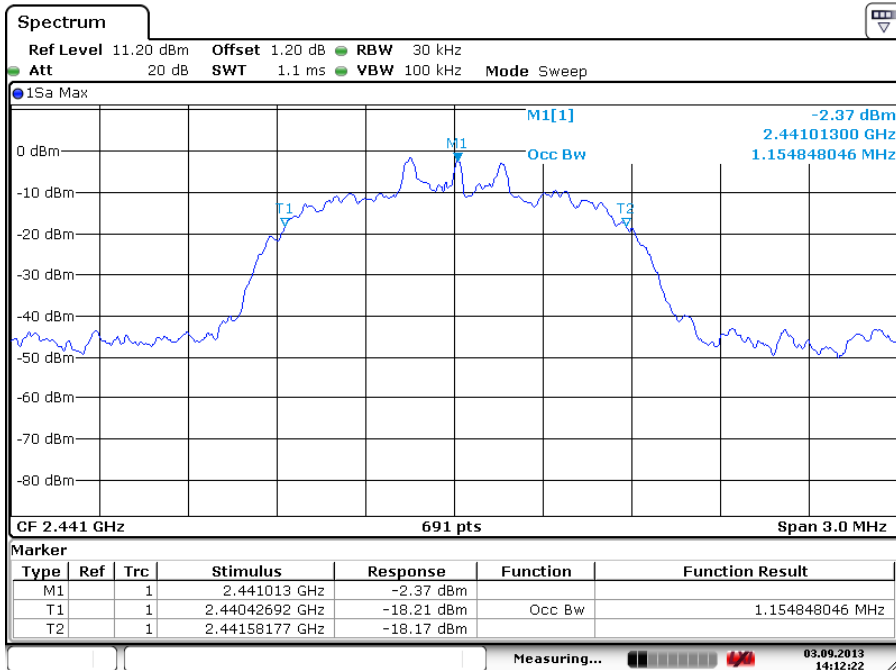

Date: 3.SEP.2013 14:12:22

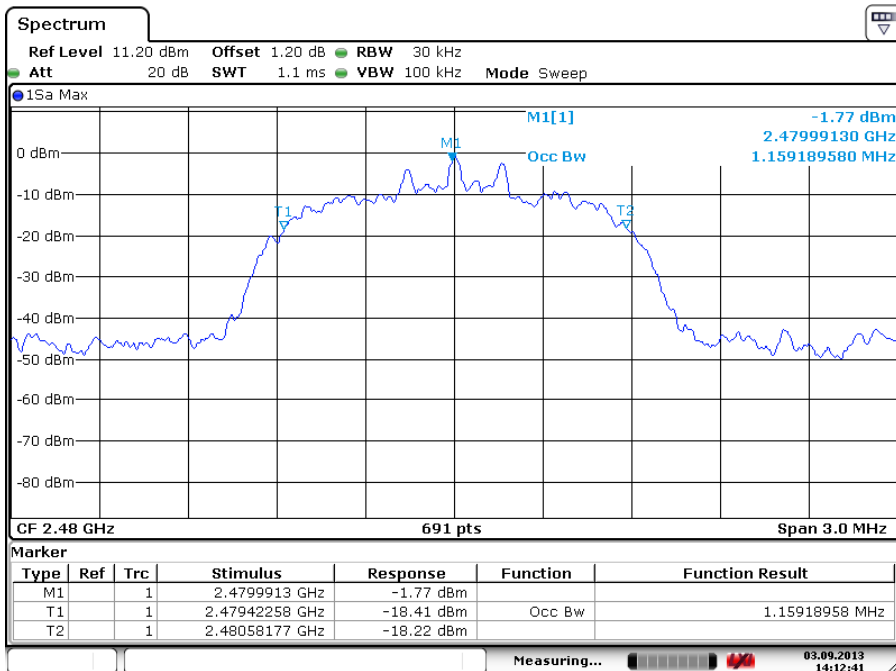
High Channel

Date: 3.SEP.2013 14:12:41

5.1.5 Conducted spurious emissions and Frequency Band Edge measured in 100kHz Bandwidth

RESULT:**Passed**

Test standard	:	FCC part 15.247(d), RSS-210 A8.5
Basic standard	:	DA 00-705 of March 30, 2000
Limit	:	20dB (below that in the 100kHz bandwidth within the band that contains the highest level of the desired power)
Kind of test site	:	Shielded room

Test setup

Test Channel	:	Low/ Middle/ High
Operation Mode	:	A
Ambient temperature	:	22-26°C
Relative humidity	:	50-65%
Atmospheric pressure	:	100-103 kPa

All emissions are more than 20dB below fundamental, details refer to following test plot, and compliance is achieved as well.

Due to the small size of the product and that there are no inductive components of significant size, 9kHz to 30MHz frequency range is not tested based on technical judgment.

Test Plot of 100kHz Conducted Emissions, GFSK modulation

Low Channel

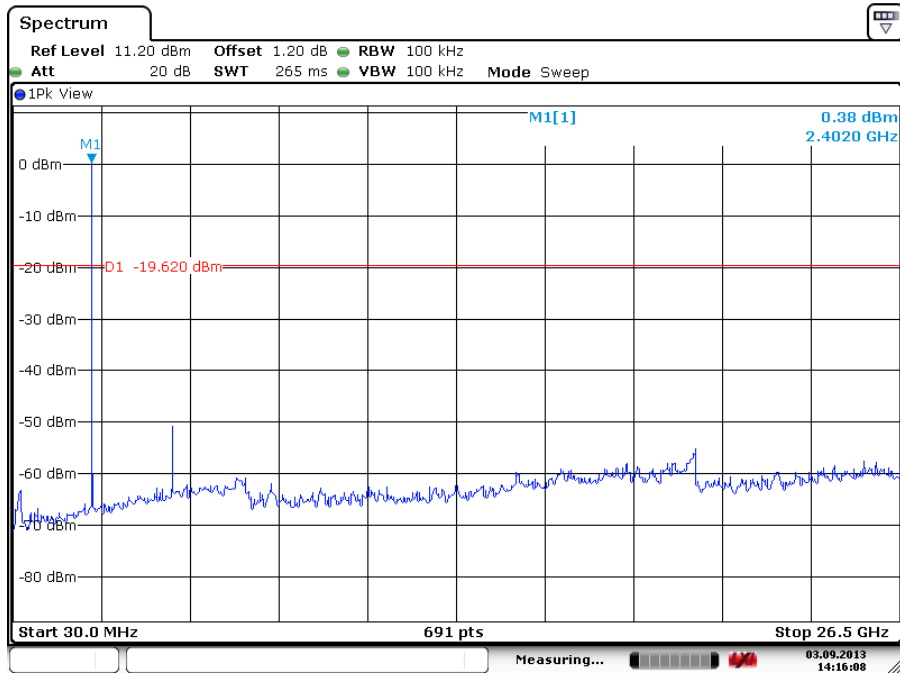

Date: 3.SEP.2013 14:16:07

Middle Channel

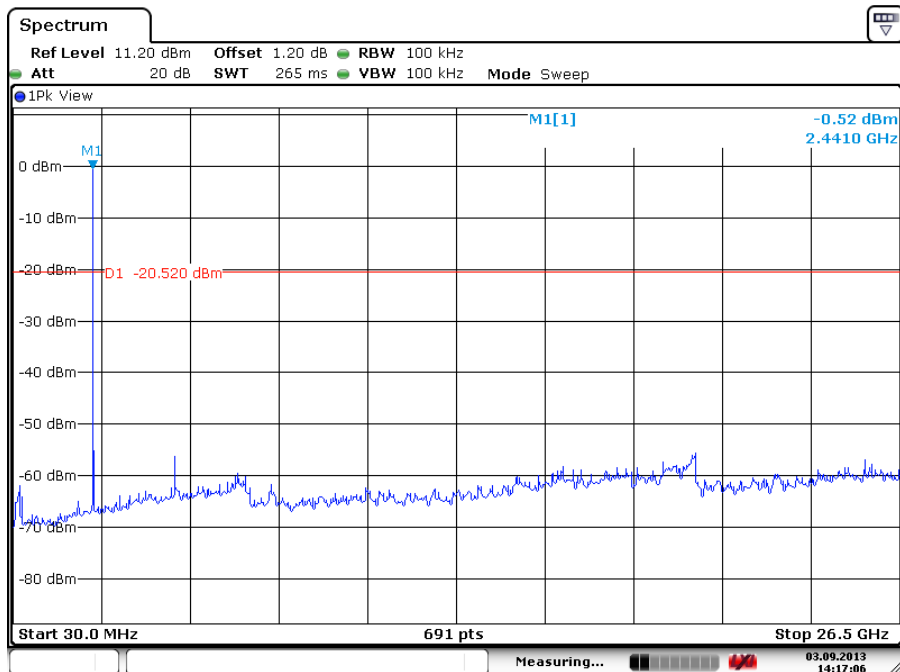

Date: 3.SEP.2013 14:17:06

High Channel

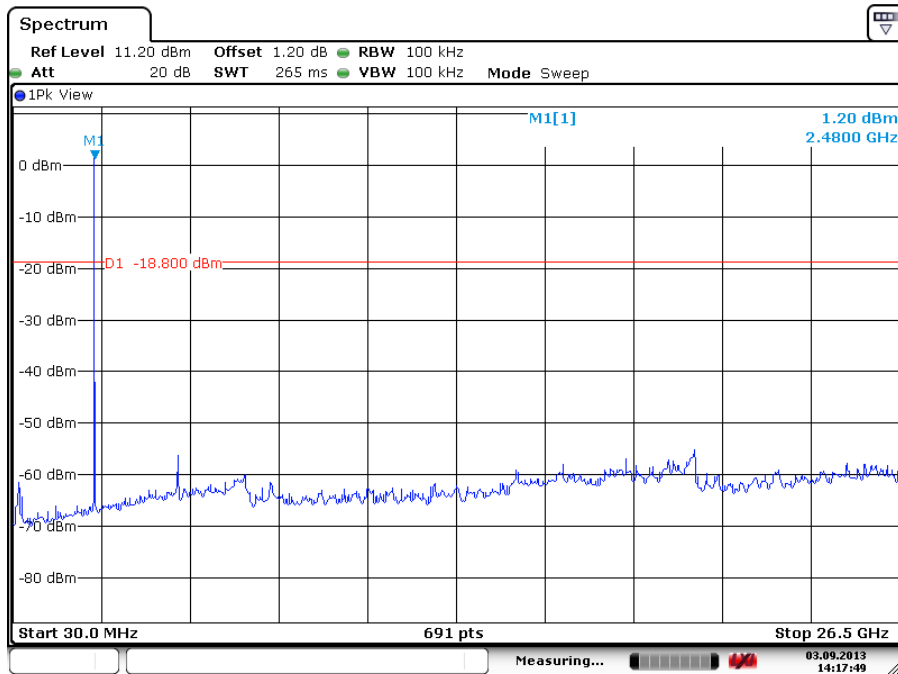

Date: 3.SEP.2013 14:17:48

Test Plot of 100kHz Conducted Emissions, 8DPSK modulation

Low Channel

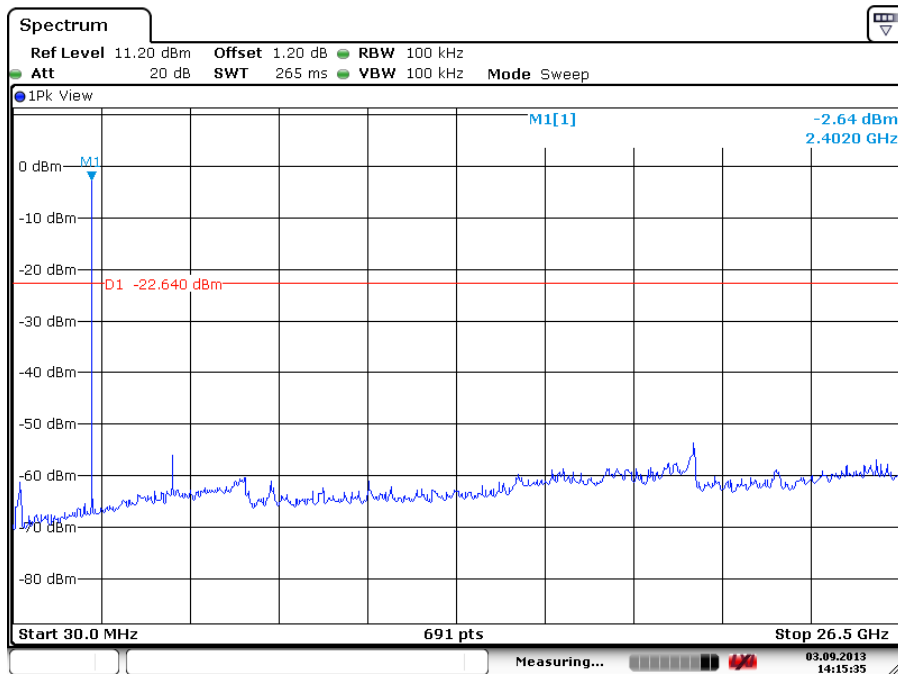

Date: 3.SEP.2013 14:15:35

Middle Channel

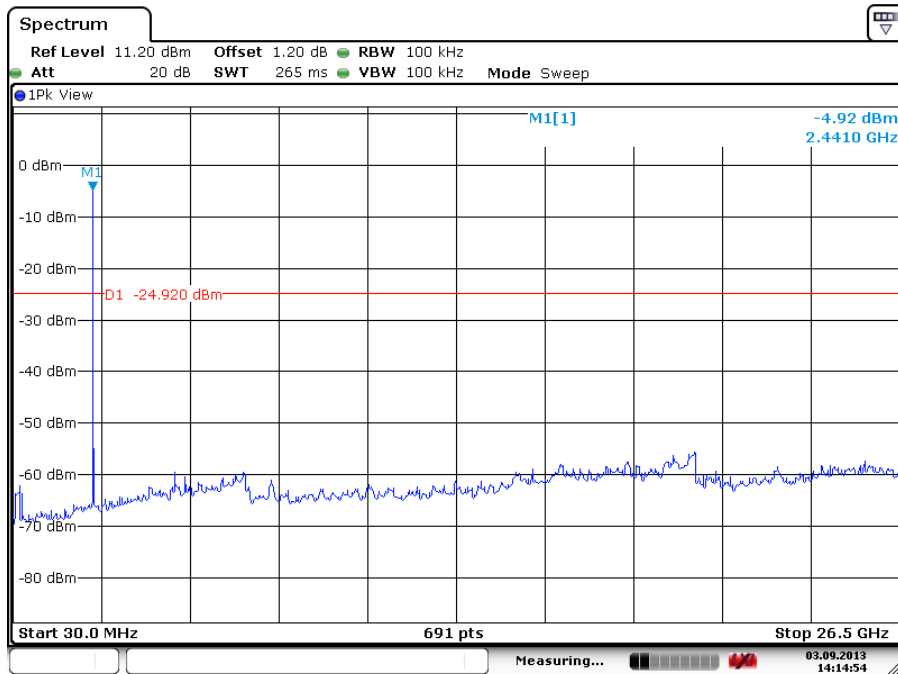

Date: 3.SEP.2013 14:14:53

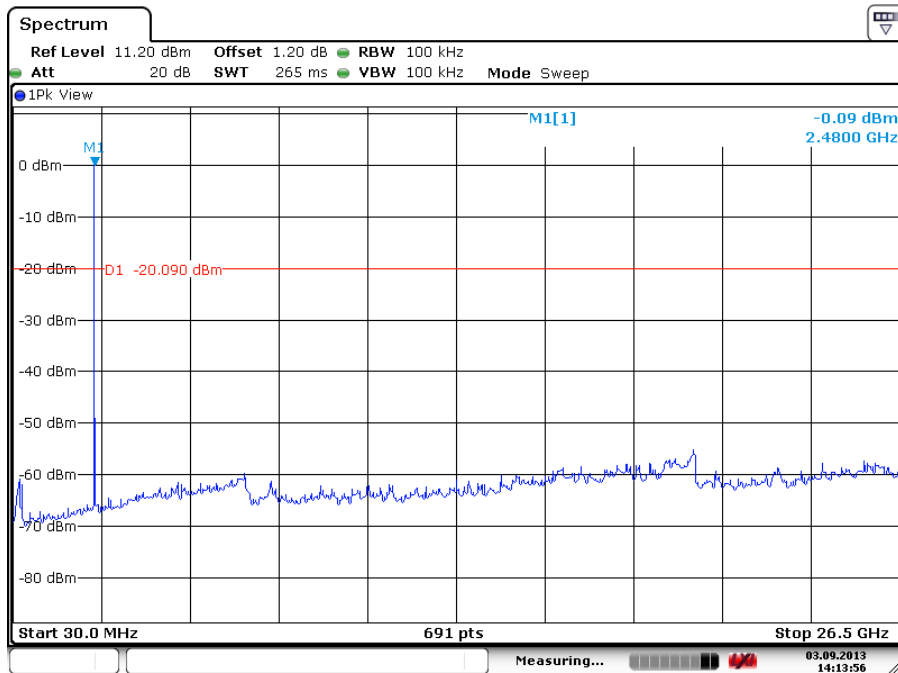
High Channel

Date: 3.SEP.2013 14:13:56

Test Plot of 100kHz Bandwidth of Frequency Band Edge, GFSK modulation

Low Channel

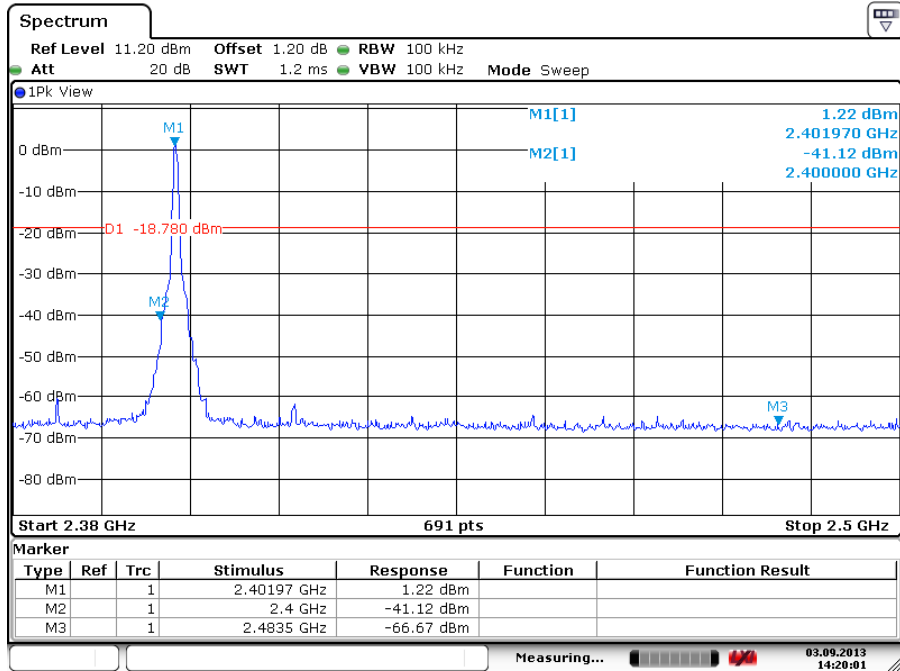

Date: 3.SEP.2013 14:20:01

High Channel

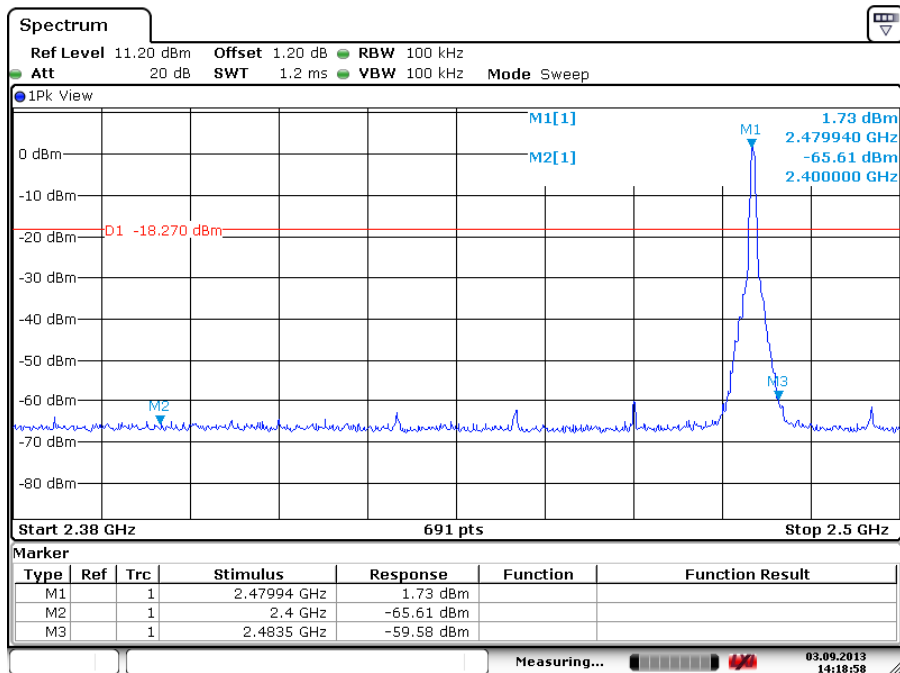

Date: 3.SEP.2013 14:18:58

Test Plot of 100kHz Bandwidth of Frequency Band Edge, 8DPSK modulation

Low Channel

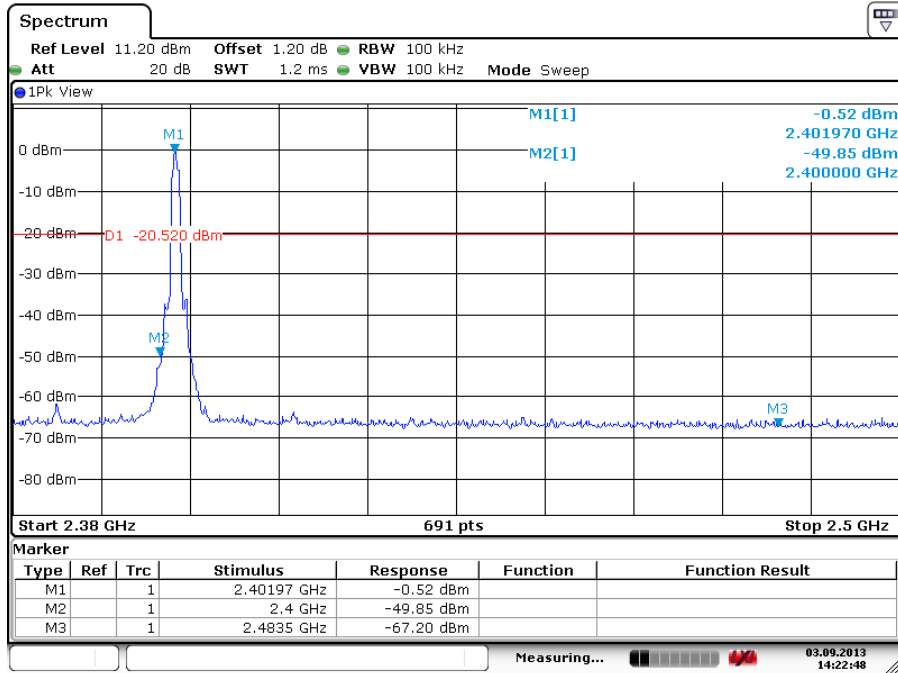

Date: 3.SEP.2013 14:22:48

High Channel

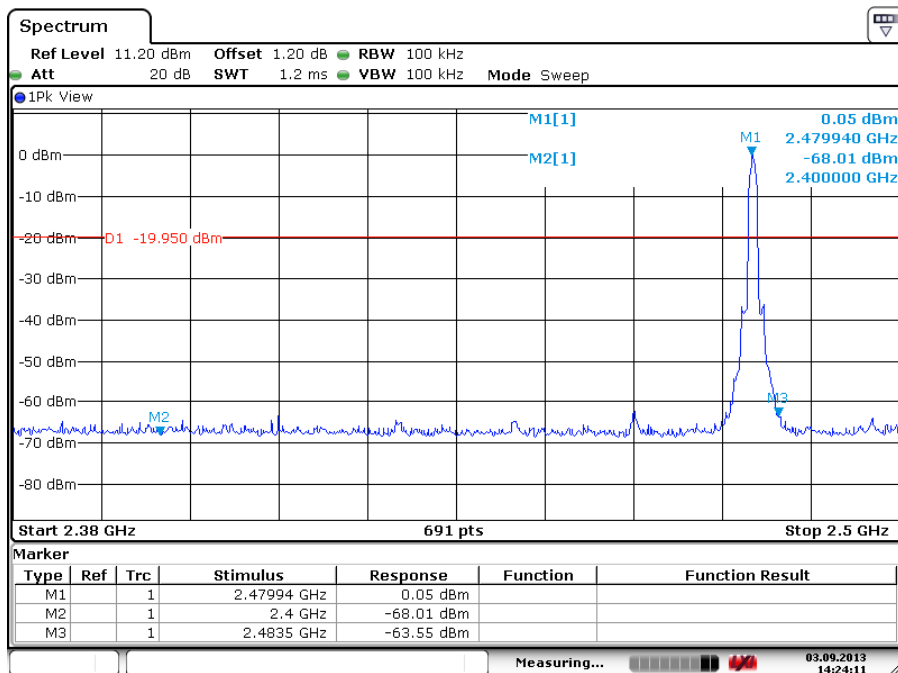

Date: 3.SEP.2013 14:24:11

5.1.6 Spurious Emission

RESULT:**Passed**

Test standard	:	FCC part 15.247(d), FCC 15.205, FCC 15.209, RSS-210 2.2, RSS-210 A8.5 and RSS-Gen 7.2.1
Basic standard	:	ANSI C63.10: 2009
Limits	:	Radiated emissions which fall in the restricted bands, as defined in FCC 15.205(a) and RSS-210 2.7 (Table 1), must comply with the radiated emission limits specified in FCC 15.209(a) and RSS-210 2.7 (Table 2 and 3). Emission radiated outside the specified frequency bands must comply with the radiated emission limits specified in FCC 15.209(a) and FCC 15.249(a), RSS-210 2.7 (Table 2 and 3) and RSS-210 A2.9(a).
Kind of test site	:	3m Semi-Anechoic Chamber

Test setup

Test Channel	:	Low/ Middle/ High
Operation Mode	:	A
Ambient temperature	:	22-26°C
Relative humidity	:	50-65%
Atmospheric pressure	:	100-103 kPa

Remark: Testing was carried out within frequency range 30MHz to the tenth harmonic. For details refer to Appendix 2. The Radiated Emissions testing was performed in the X, Y and Z axis orientation. The X Axis orientation is the worst-case and recorded in this test report. Due to the small size of the product and that there are no inductive components of significant size, 9kHz to 30MHz frequency range is not tested based on technical judgment.

5.1.7 Frequency Separation

RESULT:
Passed

Test standard : FCC part 15.247(a)(1), RSS-210 A8.1(b)
 Basic standard : DA 00-705 of March 30, 2000
 Limit : $\geq 25\text{kHz}$ or $2/3$ of 20dB bandwidth, whichever is greater

Test setup

Test Channel : Low/ Middle/ High
 Operation Mode : A

Ambient temperature : 22-26°C
 Relative humidity : 50-65%
 Atmospheric pressure : 100-103kPa

Table 13: Test result of Frequency Separation

Channel	Channel Frequency (MHz)	Measured Channel Separation (MHz)	Limit (kHz)	Result
Record Channel	2441	1	$\geq 25\text{kHz}$ or $2/3$ of 20dB bandwidth	Pass
Record Channel adj 1	2440			
Record Channel adj 2	2442			

Test Plot of Frequency Separation

GFSK

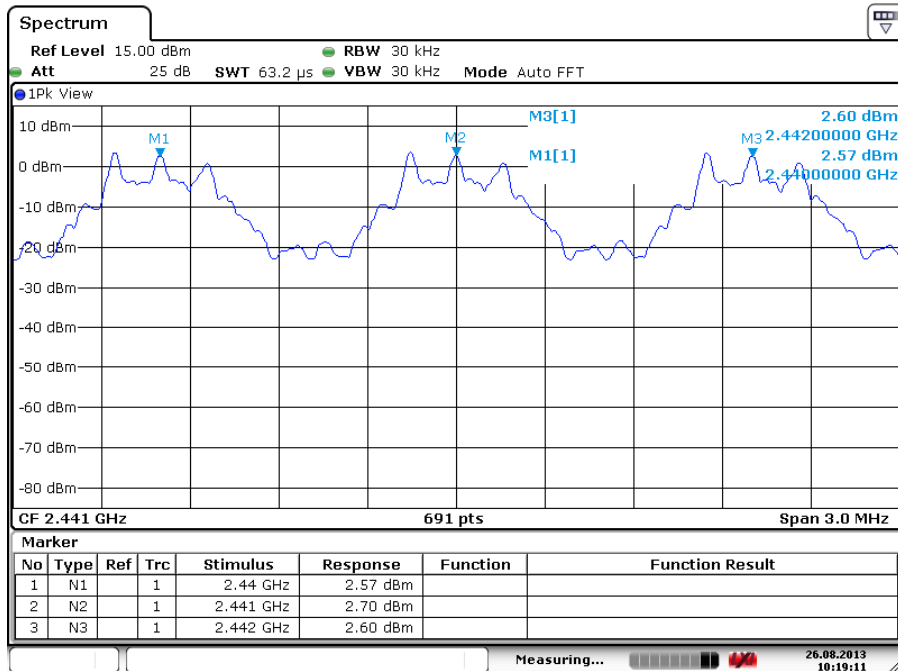

Date: 26.AUG.2013 10:19:11

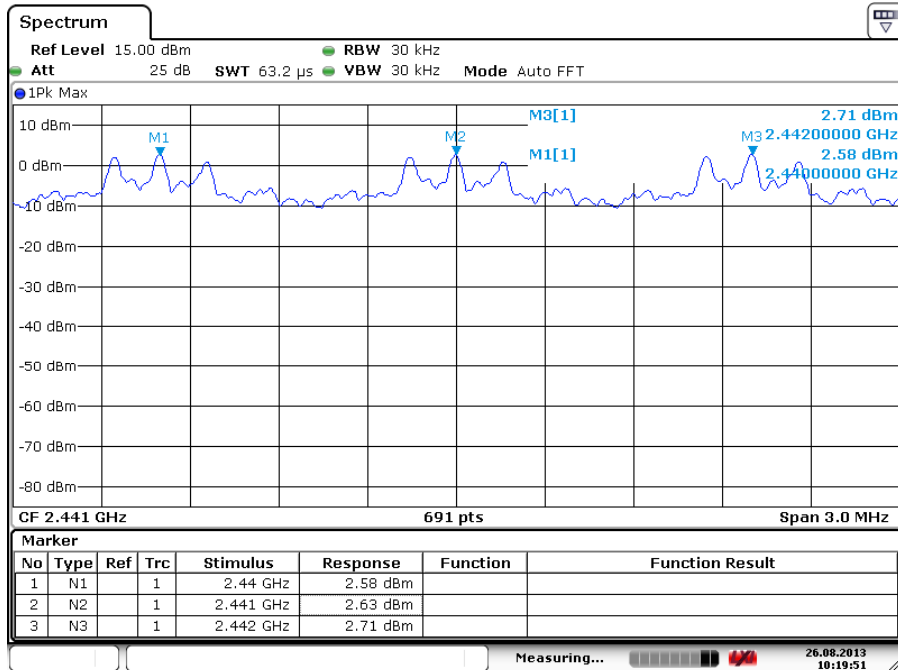

Date: 26.AUG.2013 10:19:51

5.1.8 Number of hopping frequency

RESULT:**Passed**

Test standard : FCC part 15.247(a)(1)(iii), RSS-210 A8.1(d)
Basic standard : DA 00-705 of March 30, 2000
Limits : ≥ 15 non-overlapping channels
Kind of test site : Shield room

Test setup

Test Channel : Low/ Middle/ High
Operation Mode : A

Ambient temperature : 22-26°C
Relative humidity : 50-65%
Atmospheric pressure : 100-103kPa kPa

Table 14: Test result of Number of hopping frequency

Frequency Range	Measured Quantity of Hopping Channel	Limit	Result
<u>2400</u> to <u>2483.5</u> MHz	79	≥ 15	Pass

Test Plot of Number of hopping frequencies

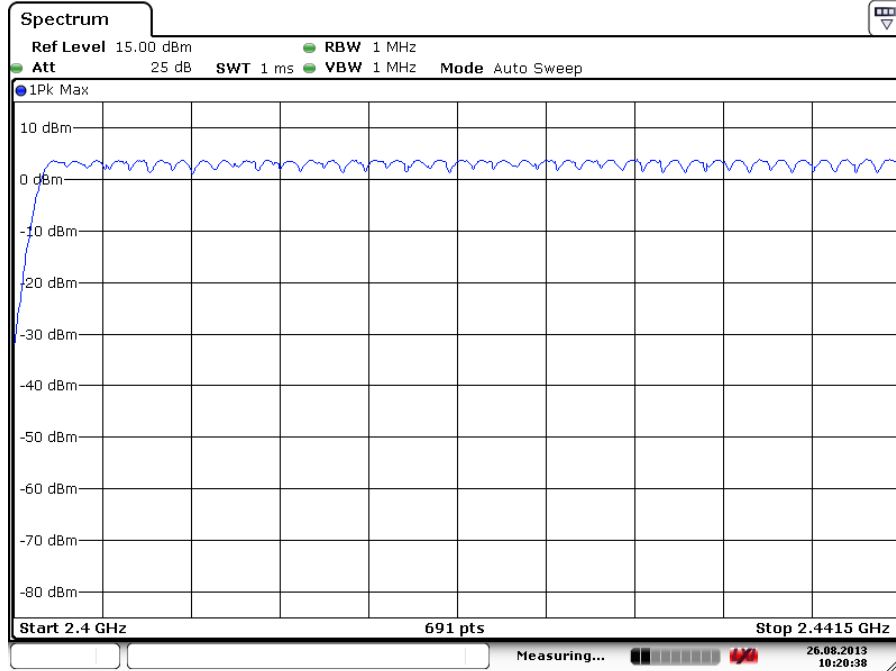

Date: 26.AUG.2013 10:20:39

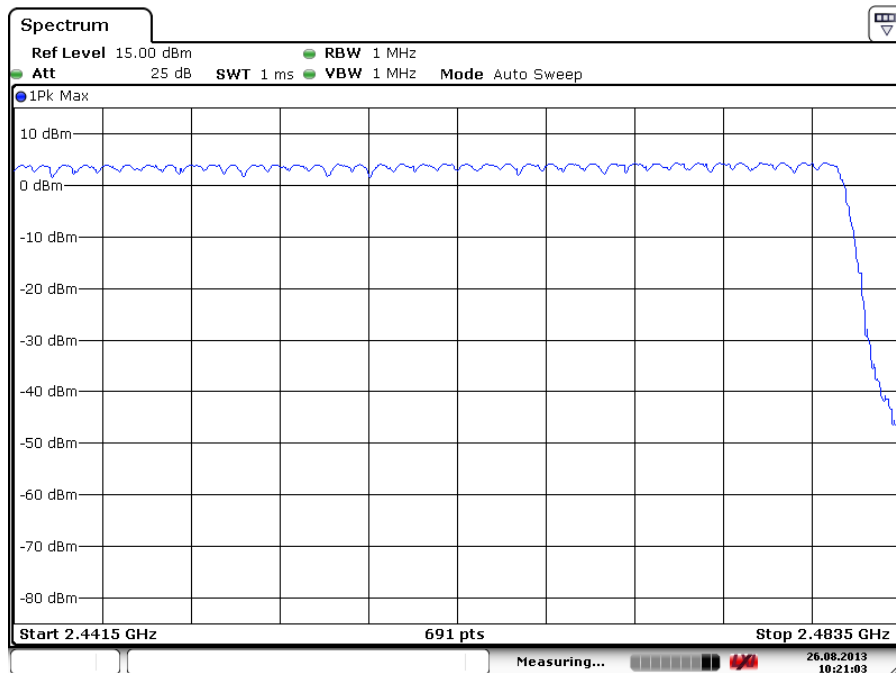

Date: 26.AUG.2013 10:21:04

5.1.9 Time of Occupancy

RESULT:
Passed

Test standard : FCC part 15.247(a)(1)(iii) , RSS-210 A8.1(d)
 Basic standard : DA 00-705 of March 30, 2000
 Limits : 0.4s
 Kind of test site : Shield room

Test setup

Test Channel : Low/ Middle/ High
 Operation Mode : A

 Ambient temperature : 22-26°C
 Relative humidity : 50-65%
 Atmospheric pressure : 100-103 kPa

Table 15: Test result of Time of Occupancy

Data Mode	Captured Burst (s)	Dwell time (s)	On+Off time (s)	Limit (s)	Result
DH5	0.0029	0.3136	0.003753	0.4	Pass
3DH5	0.0029	0.3139	0.003739	0.4	Pass

Note:

$$\text{Dwell time} = \text{Pulse width} \times (\text{Hopping rate} / \text{Number of channels}) \times \text{Period}$$

$$\text{Period} = 0.4 \text{ (seconds/ channel)} \times 79 \text{ (channel)} = 31.6 \text{ seconds.}$$

Test Plot of Time of Occupancy, GFSK modulation

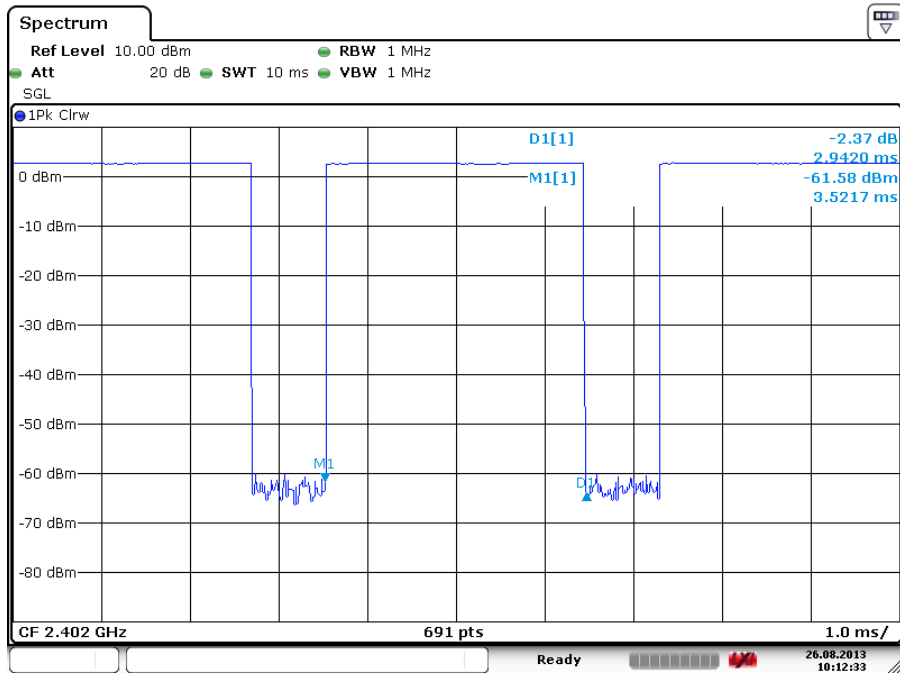

Date: 26.AUG.2013 10:12:34

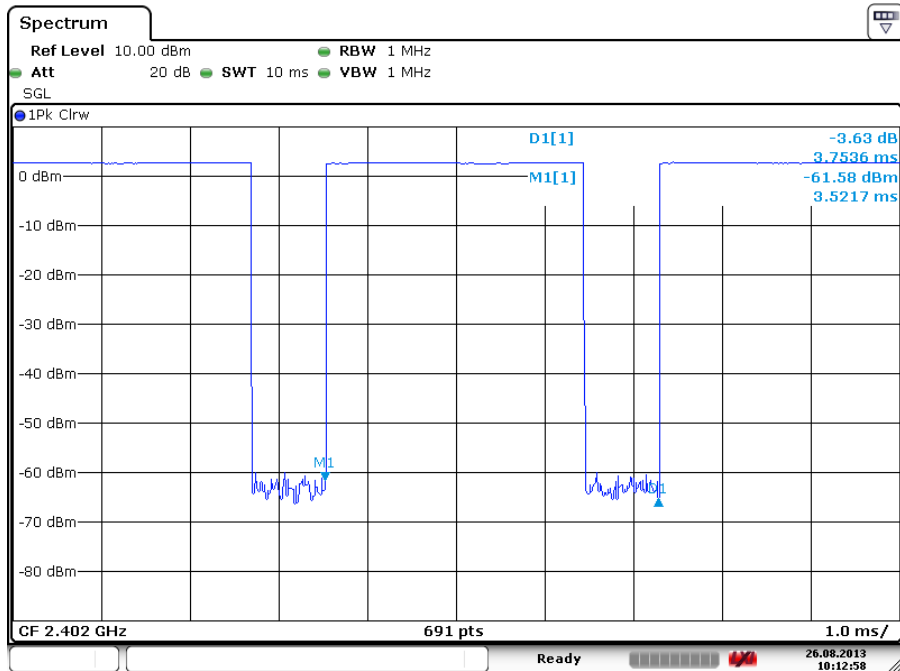

Date: 26.AUG.2013 10:12:58

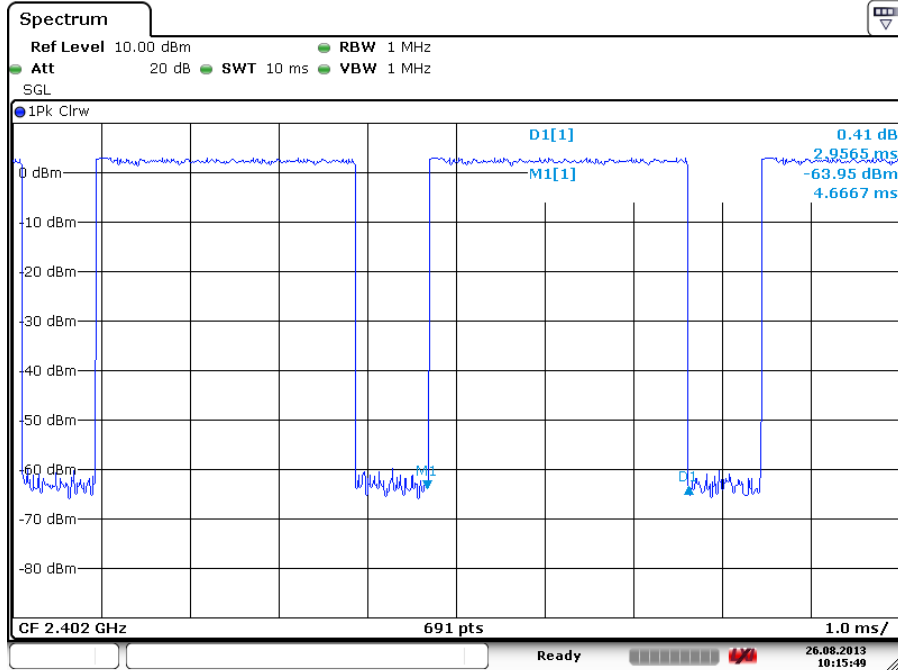
Test Plot of Time of Occupancy, 8DPSK modulation

Date: 26.AUG.2013 10:15:49

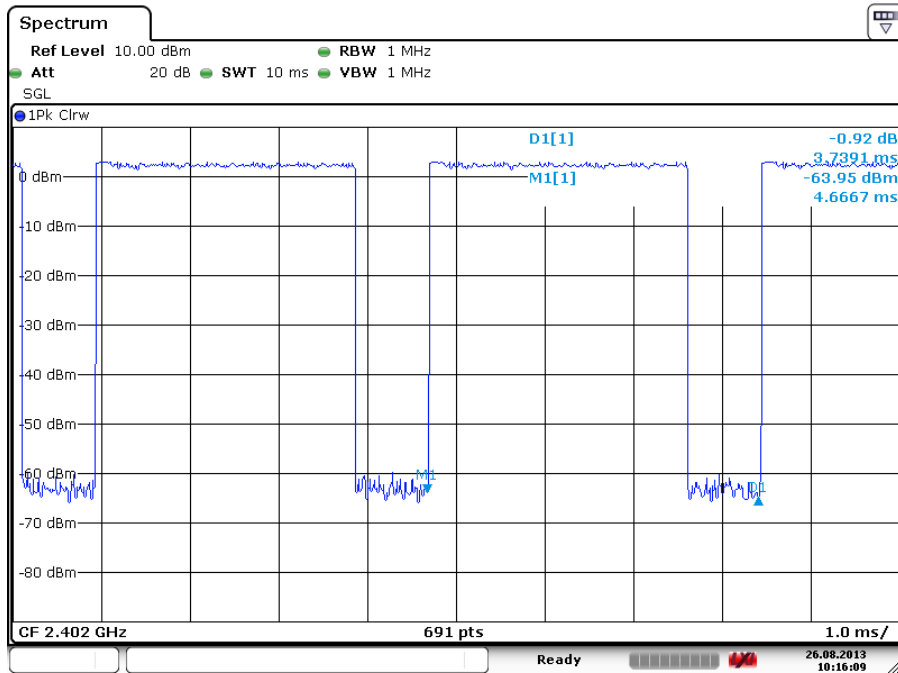

Date: 26.AUG.2013 10:16:10

6. Safety Human exposure

6.1 Radio Frequency Exposure Compliance

6.1.1 Electromagnetic Fields

RESULT:**Passed**

Test standard : FCC KDB Publication 447498

Since maximum peak output power of the transmitter is <1mW, hence the EUT is excluded from SAR evaluation according to FCC KDB publication 447498 D01: Mobile Portable RF Exposure..

7. Photographs of the Test Set-Up

Photograph 1: Set-up for Spurious Emissions (Front View)

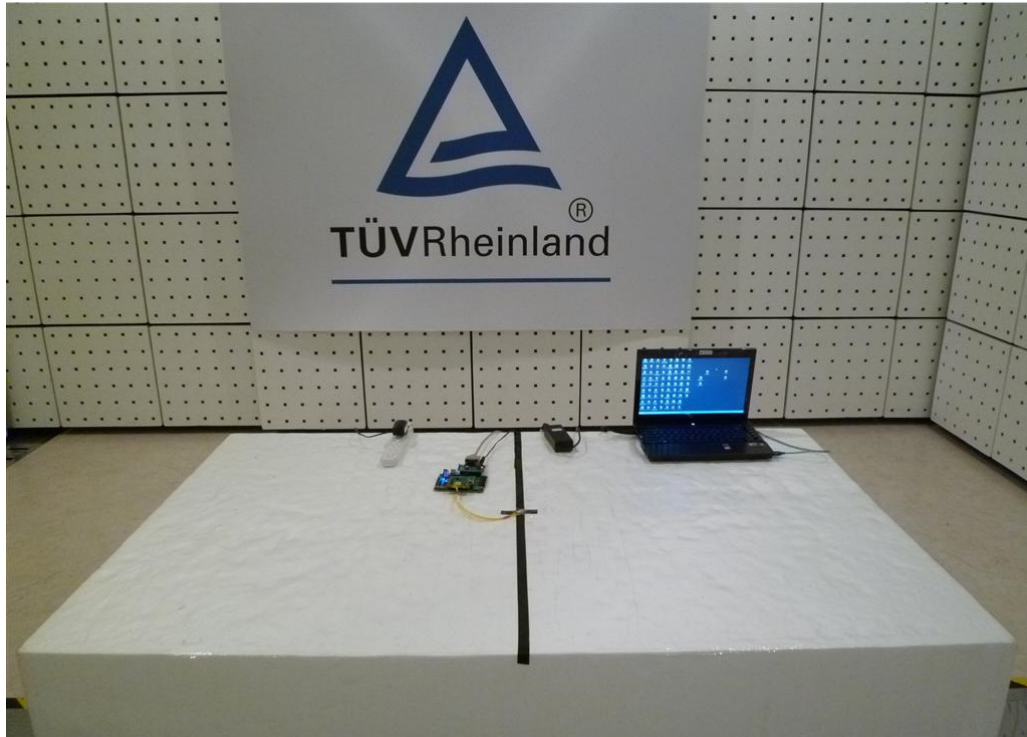

Photograph 2: Set-up for Spurious Emissions (Back View 1)

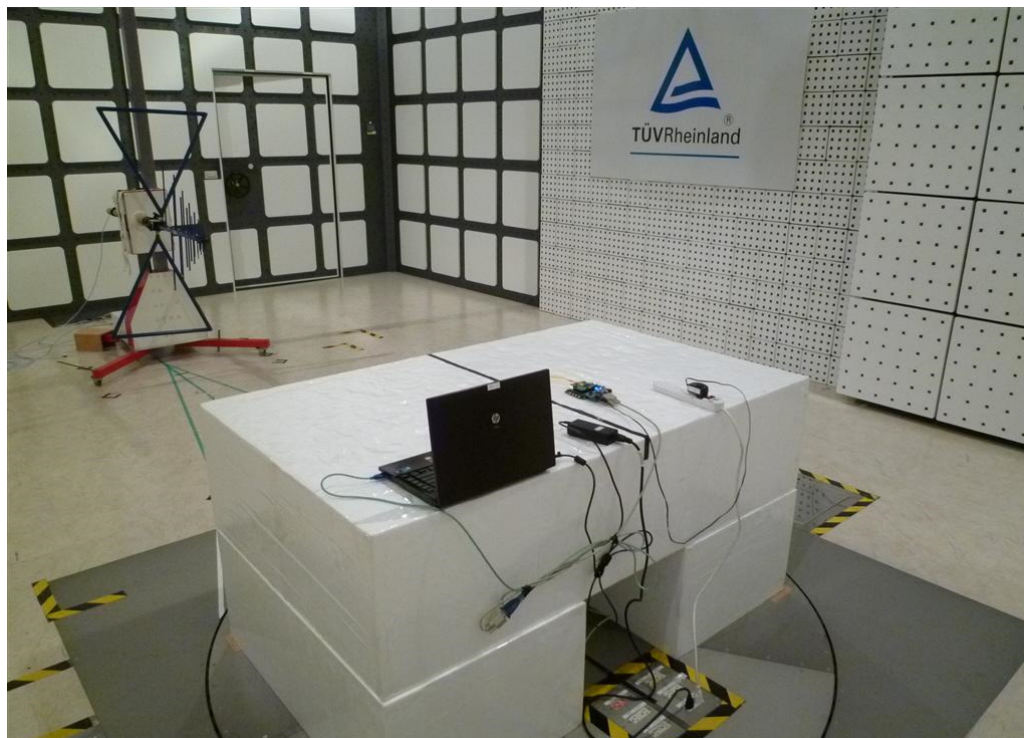

Photograph 3: Set-up for Spurious Emissions (Back View 2)



Photograph 4: Set-up for Conducted testing

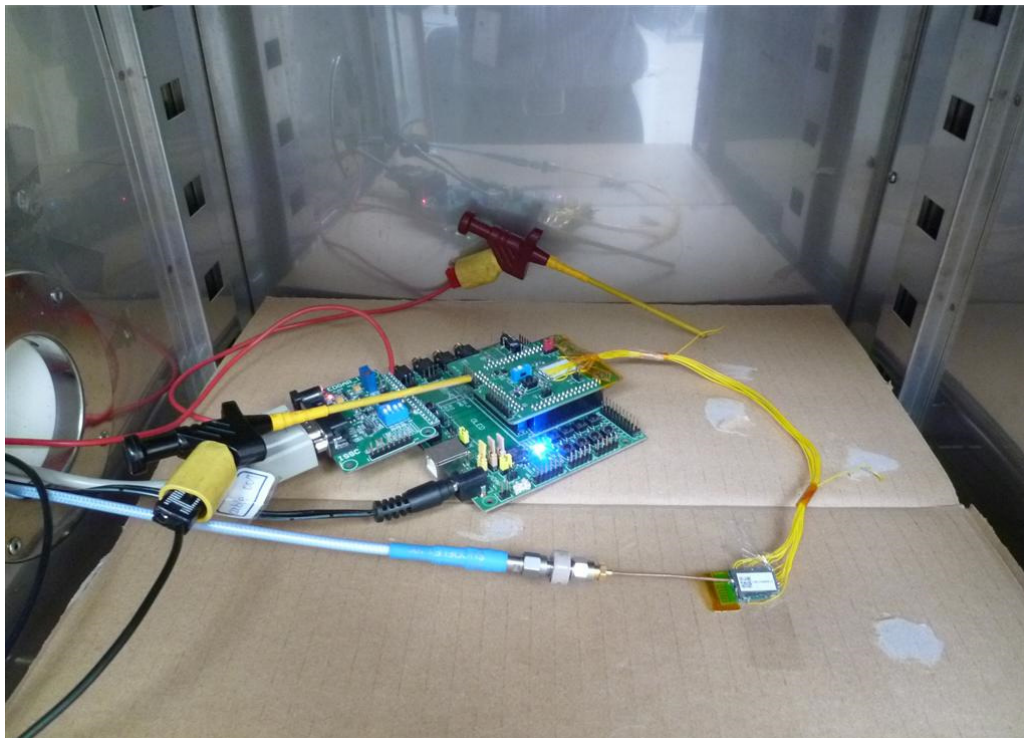

8. List of Tables

Table 1: Applied Standard and Test Levels	5
Table 2: List of Test and Measurement Equipment	6
Table 3: Emission Measurement Uncertainty.....	7
Table 4: Basic Information of EUT	8
Table 5: Technical Specification of EUT	8
Table 5: Frequency hopping information.....	9
Table 6: Test result of Peak Output Power, GFSK modulation.....	15
Table 7: Test result of Peak Output Power, 8DPSK modulation.....	15
Table 8: Test result of 20dB Bandwidth, GFSK modulation.....	19
Table 9: Test result of 20dB Bandwidth, 8DPSK modulation.....	19
Table 10: Test result of 99% Bandwidth, GFSK modulation.....	23
Table 11: Test result of 99% Bandwidth, PSK modulation.....	23
Table 12: Test result of Frequency Separation	34
Table 13: Test result of Number of hopping frequency.....	36
Table 14: Test result of Time of Occupancy.....	38

9. List of Photographs

Photograph 1: Set-up for Spurious Emissions (Front View).....	42
Photograph 2: Set-up for Spurious Emissions (Back View 1)	42
Photograph 3: Set-up for Spurious Emissions (Back View 2)	43
Photograph 4: Set-up for Conducted testing.....	43