



FCC TEST REPORT (15.247)

REPORT NO.: RF120328C18
MODEL NO.: ESR750H (refer to item 3.1 for more detail)
FCC ID: A8JESR750H
RECEIVED: Mar. 28, 2012
TESTED: Mar. 31 ~ Apr. 11, 2012
ISSUED: Apr. 16, 2012

APPLICANT: EnGenius Technologies

ADDRESS: 1580 Scenic Avenue, Costa Mesa, CA92626

ISSUED BY: Bureau Veritas Consumer Products Services
(H.K.) Ltd., Taoyuan Branch

LAB ADDRESS: No. 47, 14th Ling, Chia Pau Vil., Lin Kou Dist.,
New Taipei City, Taiwan (R.O.C.)

TEST LOCATION: No. 19, Hwa Ya 2nd Rd, Wen Hwa Tsuen, Kwei
Shan Hsiang, Taoyuan Hsien 333, Taiwan, R.O.C.

This test report consists of 76 pages in total. It may be duplicated completely for legal use with the approval of the applicant. It should not be reproduced except in full, without the written approval of our laboratory. The client should not use it to claim product certification, approval or endorsement by TAF or any government agency. The test results in the report only apply to the tested sample.



TABLE OF CONTENTS

RELEASE CONTROL RECORD.....	5
1. CERTIFICATION.....	6
2. SUMMARY OF TEST RESULTS	7
2.1 MEASUREMENT UNCERTAINTY.....	7
3. GENERAL INFORMATION.....	8
3.1 GENERAL DESCRIPTION OF EUT	8
3.2 DESCRIPTION OF TEST MODES	10
3.2.1 DESCRIPTION OF SUPPORT UNITS	11
3.2.2 CONFIGURATION OF SYSTEM UNDER TEST	11
3.2.3 TEST MODE APPLICABILITY AND TESTED CHANNEL DETAIL	12
3.3 GENERAL DESCRIPTION OF APPLIED STANDARDS	16
4. TEST TYPES AND RESULTS (FOR 2.4GHz BAND).....	17
4.1 RADIATED EMISSION AND BANDEDGE MEASUREMENT.....	17
4.1.1 LIMITS OF RADIATED EMISSION AND BANDEDGE MEASUREMENT	17
4.1.2 TEST INSTRUMENTS.....	18
4.1.3 TEST PROCEDURES	19
4.1.4 DEVIATION FROM TEST STANDARD.....	19
4.1.5 TEST SETUP.....	20
4.1.6 EUT OPERATING CONDITIONS	20
4.1.7 TEST RESULTS	21
4.2 CONDUCTED EMISSION MEASUREMENT	34
4.2.1 LIMITS OF CONDUCTED EMISSION MEASUREMENT	34
4.2.2 TEST INSTRUMENTS.....	34
4.2.3 TEST PROCEDURES	35
4.2.4 DEVIATION FROM TEST STANDARD.....	35
4.2.5 TEST SETUP.....	35
4.2.6 EUT OPERATING CONDITIONS	35
4.2.7 TEST RESULTS	36
4.3 6dB BANDWIDTH MEASUREMENT.....	38
4.3.1 LIMITS OF 6dB BANDWIDTH MEASUREMENT	38
4.3.2 TEST SETUP.....	38
4.3.3 TEST INSTRUMENTS.....	38
4.3.4 TEST PROCEDURE.....	38
4.3.5 DEVIATION FROM TEST STANDARD.....	38
4.3.6 EUT OPERATING CONDITIONS	38
4.3.7 TEST RESULTS	39
4.4 CONDUCTED OUTPUT POWER.....	40
4.4.1 LIMITS OF CONDUCTED OUTPUT POWER MEASUREMENT	40
4.4.2 TEST SETUP.....	40
4.4.3 TEST INSTRUMENTS.....	40
4.4.4 TEST PROCEDURES	40
4.4.5 DEVIATION FROM TEST STANDARD.....	40
4.4.6 EUT OPERATING CONDITIONS	40
4.4.7 TEST RESULTS	41
4.5 POWER SPECTRAL DENSITY MEASUREMENT.....	42
4.5.1 LIMITS OF POWER SPECTRAL DENSITY MEASUREMENT	42
4.5.2 TEST SETUP.....	42
4.5.3 TEST INSTRUMENTS.....	42



- 4.5.4 TEST PROCEDURE.....42
- 4.5.5 DEVIATION FROM TEST STANDARD.....42
- 4.5.6 EUT OPERATING CONDITION.....42
- 4.5.7 TEST RESULTS43
- 4.6 CONDUCTED OUT OF BAND EMISSION MEASUREMENT44
- 4.6.1 LIMITS OF CONDUCTED OUT OF BAND EMISSION MEASUREMENT44
- 4.6.2 TEST SETUP44
- 4.6.3 TEST INSTRUMENTS.....44
- 4.6.4 TEST PROCEDURE.....44
- 4.6.5 DEVIATION FROM TEST STANDARD.....45
- 4.6.6 EUT OPERATING CONDITION.....45
- 4.6.7 TEST RESULTS45
- 4.6.8 TEST RESULTS46
- 5. TEST TYPES AND RESULTS (FOR 5.0GHz BAND)50
- 5.1 RADIATED EMISSION MEASUREMENT50
- 5.1.1 LIMITS OF RADIATED EMISSION MEASUREMENT50
- 5.1.2 TEST INSTRUMENTS.....51
- 5.1.3 TEST PROCEDURES51
- 5.1.4 DEVIATION FROM TEST STANDARD.....51
- 5.1.5 TEST SETUP51
- 5.1.6 EUT OPERATING CONDITIONS51
- 5.1.7 TEST RESULTS52
- 5.2 CONDUCTED EMISSION MEASUREMENT61
- 5.2.1 LIMITS OF CONDUCTED EMISSION MEASUREMENT61
- 5.2.2 TEST INSTRUMENTS.....61
- 5.2.3 TEST PROCEDURES61
- 5.2.4 DEVIATION FROM TEST STANDARD.....61
- 5.2.5 TEST SETUP.....61
- 5.2.6 EUT OPERATING CONDITIONS61
- 5.2.7 TEST RESULTS62
- 5.3 6dB BANDWIDTH MEASUREMENT64
- 5.3.1 LIMITS OF 6dB BANDWIDTH MEASUREMENT64
- 5.3.2 TEST SETUP.....64
- 5.3.3 TEST INSTRUMENTS.....64
- 5.3.4 TEST PROCEDURE.....64
- 5.3.5 DEVIATION FROM TEST STANDARD.....64
- 5.3.6 EUT OPERATING CONDITIONS64
- 5.3.7 TEST RESULTS65
- 5.4 CONDUCTED OUTPUT POWER.....66
- 5.4.1 LIMITS OF CONDUCTED OUTPUT POWER MEASUREMENT66
- 5.4.2 TEST SETUP.....66
- 5.4.3 INSTRUMENTS.....66
- 5.4.4 TEST PROCEDURES66
- 5.4.5 DEVIATION FROM TEST STANDARD.....66
- 5.4.6 EUT OPERATING CONDITIONS66
- 5.4.7 TEST RESULTS67
- 5.5 POWER SPECTRAL DENSITY MEASUREMENT.....68
- 5.5.1 LIMITS OF POWER SPECTRAL DENSITY MEASUREMENT68
- 5.5.2 TEST SETUP.....68
- 5.5.3 TEST INSTRUMENTS.....68
- 5.5.4 TEST PROCEDURE.....68



A D T

5.5.5	DEVIATION FROM TEST STANDARD.....	68
5.5.6	EUT OPERATING CONDITION.....	68
5.5.7	TEST RESULTS	69
5.6	CONDUCTED OUT OF BAND EMISSION MEASUREMENT	70
5.6.1	LIMITS OF CONDUCTED OUT OF BAND EMISSION MEASUREMENT	70
5.6.2	TEST SETUP	70
5.6.3	TEST INSTRUMENTS.....	70
5.6.4	TEST PROCEDURE.....	70
5.6.5	DEVIATION FROM TEST STANDARD.....	70
5.6.6	EUT OPERATING CONDITION.....	70
5.6.7	TEST RESULTS	70
6.	PHOTOGRAPHS OF THE TEST CONFIGURATION.....	74
7.	INFORMATION ON THE TESTING LABORATORIES	75
8.	APPENDIX A - MODIFICATIONS RECORDERS FOR ENGINEERING CHANGES TO THE EUT BY THE LAB.....	76



A D T

RELEASE CONTROL RECORD

ISSUE NO.	REASON FOR CHANGE	DATE ISSUED
RF120328C18	Original release	Apr. 16, 2012



1. CERTIFICATION

PRODUCT: 802.11abgn Router
MODEL NO.: ESR750H (refer to item 3.1 for more detail)
BRAND: EnGenius
APPLICANT: EnGenius Technologies
TESTED: Mar. 31 ~ Apr. 11, 2012
TEST SAMPLE: ENGINEERING SAMPLE
STANDARDS: **FCC Part 15, Subpart C (Section 15.247)**
ANSI C63.10-2009

The above equipment (model: ESR750H) has been tested by **Bureau Veritas Consumer Products Services (H.K.) Ltd., Taoyuan Branch**, and found compliance with the requirement of the above standards. The test record, data evaluation & Equipment Under Test (EUT) configurations represented herein are true and accurate accounts of the measurements of the sample's EMC characteristics under the conditions specified in this report.

PREPARED BY : Andrea Hsia , DATE : Apr. 16, 2012
Andrea Hsia / Specialist

APPROVED BY : Gary Chang , DATE : Apr. 16, 2012
Gary Chang / Technical Manager

2. SUMMARY OF TEST RESULTS

The EUT has been tested according to the following specifications:

APPLIED STANDARD: FCC PART 15, SUBPART C (SECTION 15.247)			
STANDARD SECTION	TEST TYPE	RESULT	REMARK
15.207	AC Power Conducted Emission	PASS	Meet the requirement of limit. Minimum passing margin is -16.70dB at 4.60547MHz.
15.247(d) 15.209	Radiated Emissions	PASS	Meet the requirement of limit. Minimum passing margin is -1.0dB at 2386.00, 2390.00 & 2483.50MHz.
15.247(d)	Band Edge Measurement	PASS	Meet the requirement of limit.
15.247(a)(2)	6dB bandwidth	PASS	Meet the requirement of limit.
15.247(b)	Conducted power	PASS	Meet the requirement of limit.
15.247(e)	Power Spectral Density	PASS	Meet the requirement of limit.
15.203	Antenna Requirement	PASS	2.4GHz: Antenna connector is IPEX not a standard connector. 5.0GHz: Antenna connector is UFL not a standard connector.

2.1 MEASUREMENT UNCERTAINTY

Where relevant, the following measurement uncertainty levels have been estimated for tests performed on the EUT as specified in CISPR 16-4-2:

MEASUREMENT	FREQUENCY	UNCERTAINTY
Conducted emissions	9kHz~30MHz	2.44 dB
Radiated emissions	30MHz ~ 200MHz	3.34 dB
	200MHz ~1000MHz	3.35 dB
	1GHz ~ 18GHz	2.26 dB
	18GHz ~ 40GHz	1.94 dB

This uncertainty represents an expanded uncertainty expressed at approximately the 95% confidence level using a coverage factor of $k = 2$.

3. GENERAL INFORMATION

3.1 GENERAL DESCRIPTION OF EUT

EUT	802.11abgn Router
MODEL NO.	ESR750H (refer to note as below)
POWER SUPPLY	12Vdc (Adapter)
MODULATION TYPE	CCK, DQPSK, DBPSK for DSSS 64QAM, 16QAM, QPSK, BPSK for OFDM
MODULATION TECHNOLOGY	DSSS, OFDM
TRANSFER RATE	802.11b: 11.0/ 5.5/ 2.0/ 1.0Mbps 802.11g: 54.0/ 48.0/ 36.0/ 24.0/ 18.0/ 12.0/ 9.0/ 6.0Mbps 802.11a: 54.0/ 48.0/ 36.0/ 24.0/ 18.0/ 12.0/ 9.0/ 6.0Mbps 802.11n: up to 450.0Mbps
OPERATING FREQUENCY	2.4GHz: 2412 ~ 2462MHz 5.0GHz: 5745 ~ 5825MHz
NUMBER OF CHANNEL	2.4GHz: 11 for 802.11b, 802.11g, 802.11n (20MHz) 7 for 802.11n (40MHz) 5.0GHz: 5 for 802.11a, 802.11n (20MHz) 2 for 802.11n (40MHz)
OUTPUT POWER	390.9mW for 2412 ~ 2462MHz 634.7mW for 5745 ~ 5825MHz
ANTENNA TYPE	2.4GHz: Dipole External antenna with 5dBi gain 5.0GHz: PIFA Internal antenna with 3.5dBi gain
ANTENNA CONNECTOR	2.4GHz: IPEX 5.0GHz: UFL
DATA CABLE	NA
I/O PORTS	Refer to user's manual
ACCESSORY DEVICES	Adapter

NOTE:

- The following models are electrically identical, different model names are for marketing purpose.

BRAND	MODEL
EnGenius	ESR750H
	ESR600H

- The frequency bands used in this EUT are listed as follows:

Frequency Band (MHz)	2412~2462	5180~5240	5745~5825
802.11b	√		
802.11g	√		
802.11a		√	√
802.11n (20MHz)	√	√	√
802.11n (40MHz)	√	√	√

3. The EUT incorporates a MIMO function. Physically, the EUT provides 3 completed transmitters and 3 receivers.

MODULATION MODE	TX FUNCTION
802.11b	1TX
802.11g	1TX
802.11n (20MHz)	2TX
802.11n (40MHz)	2TX

MODULATION MODE	TX FUNCTION
802.11a	1TX
802.11n (20MHz)	3TX
802.11n (40MHz)	3TX

** Diversity function is not supported for 1 TX mode. Only chain 0 will transmit 802.11 b/g/a signal.

4. The EUT consumes power from the following adapter.

BRAND:	AMIGO
MODEL:	AMS3-1201250FU
INPUT:	100-240Vac, 50/60Hz, 0.5A
OUTPUT:	12Vdc, 1.25A
POWER LINE:	1.8m non-shielded cable without core

5. The above EUT information is declared by manufacturer and for more detailed features description, please refer to the manufacturer's specifications or user's manual.

3.2 DESCRIPTION OF TEST MODES

FOR 2.4GHz:

11 channels are provided for 802.11b, 802.11g and 802.11n (20MHz):

CHANNEL	FREQUENCY	CHANNEL	FREQUENCY
1	2412MHz	7	2442MHz
2	2417MHz	8	2447MHz
3	2422MHz	9	2452MHz
4	2427MHz	10	2457MHz
5	2432MHz	11	2462MHz
6	2437MHz		

7 channels are provided for 802.11n (40MHz):

CHANNEL	FREQUENCY	CHANNEL	FREQUENCY
3	2422MHz	7	2442MHz
4	2427MHz	8	2447MHz
5	2432MHz	9	2452MHz
6	2437MHz		

FOR 5.0GHz (5745 ~ 5825MHz):

5 channels are provided for 802.11a, 802.11n (20MHz):

CHANNEL	FREQUENCY	CHANNEL	FREQUENCY
149	5745MHz	161	5805MHz
153	5765MHz	165	5825MHz
157	5785MHz		

2 channels are provided for 802.11n (40MHz):

CHANNEL	FREQUENCY	CHANNEL	FREQUENCY
151	5755MHz	159	5795MHz

3.2.1 DESCRIPTION OF SUPPORT UNITS

The EUT has been tested as an independent unit together with other necessary accessories or support units. The following support units or accessories were used to form a representative test configuration during the tests.

NO.	PRODUCT	BRAND	MODEL NO.	SERIAL NO.	FCC ID
1	NOTEBOOK	DELL	E5410	1HC2XM1	FCC DoC Approved
2	NOTEBOOK	DELL	E5410	6RP2YM1	FCC DoC Approved
3	USB DONGLE	Transcend	V30	N/A	N/A

NO.	SIGNAL CABLE DESCRIPTION OF THE ABOVE SUPPORT UNITS
1	10m RJ45 cable
2	10m RJ45 cable
3	N/A

NOTE:

1. All power cords of the above support units are non shielded (1.8m).
2. Item 1 ~ 2 acted as communication partner to transfer data.

3.2.2 CONFIGURATION OF SYSTEM UNDER TEST

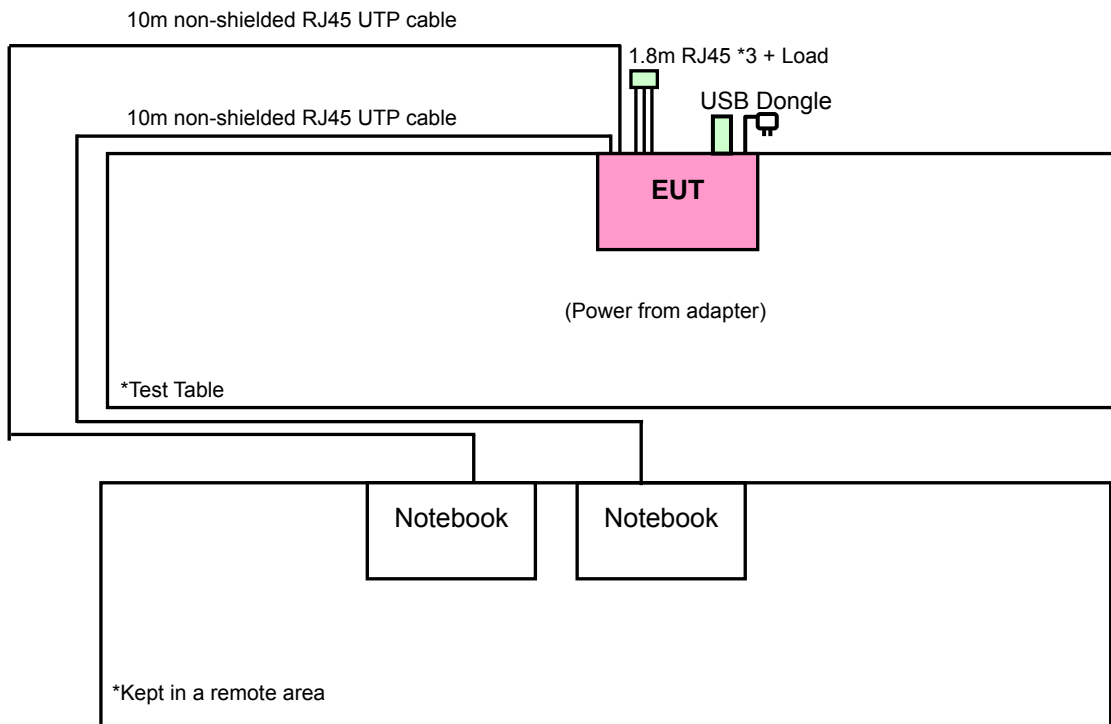

3.2.3 TEST MODE APPLICABILITY AND TESTED CHANNEL DETAIL

FOR 2.4GHz:

EUT CONFIGURE MODE	APPLICABLE TO				DESCRIPTION
	RE \geq 1G	RE<1G	PLC	APCM	
-	√	√	√	√	-

Where **RE \geq 1G**: Radiated Emission above 1GHz

RE<1G: Radiated Emission below 1GHz

PLC: Power Line Conducted Emission

APCM: Antenna Port Conducted Measurement

NOTE: The EUT had been pre-tested on the positioned of each 3 axis. The worst case was found when positioned on Z-plane.

RADIATED EMISSION TEST (ABOVE 1GHz):

- Pre-Scan has been conducted to determine the worst-case mode from all possible combinations between available modulations, data rates and antenna ports (if EUT with antenna diversity architecture).
- Following channel(s) was (were) selected for the final test as listed below.

MODE	AVAILABLE CHANNEL	TESTED CHANNEL	MODULATION TECHNOLOGY	MODULATION TYPE	DATA RATE (Mbps)
802.11b	1 to 11	1, 6, 11	DSSS	DBPSK	1.0
802.11g	1 to 11	1, 6, 11	OFDM	BPSK	6.0
802.11n (20MHz)	1 to 11	1, 6, 11	OFDM	BPSK	7.2
802.11n (40MHz)	3 to 9	3, 6, 9	OFDM	BPSK	15.0

RADIATED EMISSION TEST (BELOW 1GHz):

- Pre-Scan has been conducted to determine the worst-case mode from all possible combinations between available modulations, data rates and antenna ports (if EUT with antenna diversity architecture).
- Following channel(s) was (were) selected for the final test as listed below.

MODE	AVAILABLE CHANNEL	TESTED CHANNEL	MODULATION TECHNOLOGY	MODULATION TYPE	DATA RATE (Mbps)
802.11n (20MHz)	1 to 11	11	OFDM	BPSK	7.2

POWER LINE CONDUCTED EMISSION TEST:

- Pre-Scan has been conducted to determine the worst-case mode from all possible combinations between available modulations, data rates and antenna ports (if EUT with antenna diversity architecture).
- Following channel(s) was (were) selected for the final test as listed below.

MODE	AVAILABLE CHANNEL	TESTED CHANNEL	MODULATION TECHNOLOGY	MODULATION TYPE	DATA RATE (Mbps)
802.11n (20MHz)	1 to 11	11	OFDM	BPSK	7.2

BANDEDGE MEASUREMENT:

- Pre-Scan has been conducted to determine the worst-case mode from all possible combinations between available modulations, data rates and antenna ports (if EUT with antenna diversity architecture).
- Following channel(s) was (were) selected for the final test as listed below.

MODE	AVAILABLE CHANNEL	TESTED CHANNEL	MODULATION TECHNOLOGY	MODULATION TYPE	DATA RATE (Mbps)
802.11b	1 to 11	1, 11	DSSS	DBPSK	1.0
802.11g	1 to 11	1, 11	OFDM	BPSK	6.0
802.11n (20MHz)	1 to 11	1, 11	OFDM	BPSK	7.2
802.11n (40MHz)	3 to 9	3, 9	OFDM	BPSK	15.0

ANTENNA PORT CONDUCTED MEASUREMENT:

- This item includes all test value of each mode, but only includes spectrum plot of worst value of each mode.
- Pre-Scan has been conducted to determine the worst-case mode from all possible combinations between available modulations, data rates and antenna ports (if EUT with antenna diversity architecture).
- Following channel(s) was (were) selected for the final test as listed below.

MODE	AVAILABLE CHANNEL	TESTED CHANNEL	MODULATION TECHNOLOGY	MODULATION TYPE	DATA RATE (Mbps)
802.11b	1 to 11	1, 6, 11	DSSS	DBPSK	1.0
802.11g	1 to 11	1, 6, 11	OFDM	BPSK	6.0
802.11n (20MHz)	1 to 11	1, 6, 11	OFDM	BPSK	7.2
802.11n (40MHz)	3 to 9	3, 6, 9	OFDM	BPSK	15.0

TEST CONDITION:

APPLICABLE TO	ENVIRONMENTAL CONDITIONS	INPUT POWER	TESTED BY
RE \geq 1G	25deg. C, 65%RH	120Vac, 60Hz	Aska Huang
RE $<$ 1G	25deg. C, 65%RH	120Vac, 60Hz	Aska Huang
PLC	25deg. C, 65%RH	120Vac, 60Hz	Haru Yang
APCM	25deg. C, 65%RH	120Vac, 60Hz	Aska Huang

FOR 5.0GHz (5745 ~ 5825MHz):

EUT CONFIGURE MODE	APPLICABLE TO				DESCRIPTION
	RE≥1G	RE<1G	PLC	APCM	
-	√	√	√	√	-

Where **RE≥1G**: Radiated Emission above 1GHz **RE<1G**: Radiated Emission below 1GHz
PLC: Power Line Conducted Emission **APCM**: Antenna Port Conducted Measurement

NOTE: The EUT had been pre-tested on the positioned of each 3 axis. The worst case was found when positioned on Z-plane.

RADIATED EMISSION TEST (ABOVE 1GHz):

- Pre-Scan has been conducted to determine the worst-case mode from all possible combinations between available modulations, data rates and antenna ports (if EUT with antenna diversity architecture).
- Following channel(s) was (were) selected for the final test as listed below.

MODE	AVAILABLE CHANNEL	TESTED CHANNEL	MODULATION TECHNOLOGY	MODULATION TYPE	DATA RATE (Mbps)
802.11a	149 to 165	149, 157, 165	OFDM	BPSK	6.0
802.11n (20MHz)	149 to 165	149, 157, 165	OFDM	BPSK	7.2
802.11n (40MHz)	151 to 159	151, 159	OFDM	BPSK	15.0

RADIATED EMISSION TEST (BELOW 1GHz):

- Pre-Scan has been conducted to determine the worst-case mode from all possible combinations between available modulations, data rates and antenna ports (if EUT with antenna diversity architecture).
- Following channel(s) was (were) selected for the final test as listed below.

MODE	AVAILABLE CHANNEL	TESTED CHANNEL	MODULATION TECHNOLOGY	MODULATION TYPE	DATA RATE (Mbps)
802.11n (20MHz)	149 to 165	149	OFDM	BPSK	7.2

POWER LINE CONDUCTED EMISSION TEST:

- Pre-Scan has been conducted to determine the worst-case mode from all possible combinations between available modulations, data rates and antenna ports (if EUT with antenna diversity architecture).
- Following channel(s) was (were) selected for the final test as listed below.

MODE	AVAILABLE CHANNEL	TESTED CHANNEL	MODULATION TECHNOLOGY	MODULATION TYPE	DATA RATE (Mbps)
802.11n (20MHz)	149 to 165	149	OFDM	BPSK	7.2

BANDEDGE MEASUREMENT:

- Pre-Scan has been conducted to determine the worst-case mode from all possible combinations between available modulations, data rates and antenna ports (if EUT with antenna diversity architecture).
- Following channel(s) was (were) selected for the final test as listed below.

MODE	AVAILABLE CHANNEL	TESTED CHANNEL	MODULATION TECHNOLOGY	MODULATION TYPE	DATA RATE (Mbps)
802.11a	149 to 165	149, 165	OFDM	BPSK	6.0
802.11n (20MHz)	149 to 165	149, 165	OFDM	BPSK	7.2
802.11n (40MHz)	151 to 159	151, 159	OFDM	BPSK	15.0

ANTENNA PORT CONDUCTED MEASUREMENT:

- This item includes all test value of each mode, but only includes spectrum plot of worst value of each mode.
- Pre-Scan has been conducted to determine the worst-case mode from all possible combinations between available modulations, data rates and antenna ports (if EUT with antenna diversity architecture).
- Following channel(s) was (were) selected for the final test as listed below.

MODE	AVAILABLE CHANNEL	TESTED CHANNEL	MODULATION TECHNOLOGY	MODULATION TYPE	DATA RATE (Mbps)
802.11a	149 to 165	149, 157, 165	OFDM	BPSK	6.0
802.11n (20MHz)	149 to 165	149, 157, 165	OFDM	BPSK	7.2
802.11n (40MHz)	151 to 159	151, 159	OFDM	BPSK	15.0

TEST CONDITION:

APPLICABLE TO	ENVIRONMENTAL CONDITIONS	INPUT POWER	TESTED BY
RE≥1G	25deg. C, 65%RH	120Vac, 60Hz	Aska Huang
RE<1G	25deg. C, 65%RH	120Vac, 60Hz	Aska Huang
PLC	25deg. C, 65%RH	120Vac, 60Hz	Haru Yang
APCM	25deg. C, 65%RH	120Vac, 60Hz	Aska Huang

3.3 GENERAL DESCRIPTION OF APPLIED STANDARDS

The EUT is a RF Product. According to the specifications of the manufacturer, it must comply with the requirements of the following standards:

FCC Part 15, Subpart C (15.247)

ANSI C63.10-2009

All test items have been performed and recorded as per the above standards.

NOTE: The EUT is also considered as a kind of computer peripheral, because the connection to computer is necessary for typical use. It has been verified to comply with the requirements of FCC Part 15, Subpart B, Class B (DoC). The test report has been issued separately.

4. TEST TYPES AND RESULTS (FOR 2.4GHz BAND)

4.1 RADIATED EMISSION AND BANDEDGE MEASUREMENT

4.1.1 LIMITS OF RADIATED EMISSION AND BANDEDGE MEASUREMENT

Radiated emissions which fall in the restricted bands must comply with the radiated emission limits specified as below table. Other emissions shall be at least 20dB below the highest level of the desired power:

FREQUENCIES (MHz)	FIELD STRENGTH (microvolts/meter)	MEASUREMENT DISTANCE (meters)
0.009 ~ 0.490	2400/F(kHz)	300
0.490 ~ 1.705	24000/F(kHz)	30
1.705 ~ 30.0	30	30
30 ~ 88	100	3
88 ~ 216	150	3
216 ~ 960	200	3
Above 960	500	3

NOTE:

1. The lower limit shall apply at the transition frequencies.
2. Emission level (dBuV/m) = 20 log Emission level (uV/m).
3. For frequencies above 1000MHz, the field strength limits are based on average detector, however, the peak field strength of any emission shall not exceed the maximum permitted average limits, specified above by more than 20dB under any condition of modulation.

4.1.2 TEST INSTRUMENTS

DESCRIPTION & MANUFACTURER	MODEL NO.	SERIAL NO.	DATE OF CALIBRATION	DUE DATE OF CALIBRATION
Test Receiver ROHDE & SCHWARZ	ESIB7	100212	Aug. 02, 2011	Aug. 01, 2012
Spectrum Analyzer ROHDE & SCHWARZ	FSP40	100041	Jul. 21, 2011	Jul. 20, 2012
BILOG Antenna SCHWARZBECK	VULB9168	9168-160	Apr. 13, 2011	Apr. 12, 2012
HORN Antenna SCHWARZBECK	9120D	209	Aug. 25, 2011	Aug. 24, 2012
HORN Antenna SCHWARZBECK	BBHA 9170	148	Jul. 20, 2011	Jul. 19, 2012
Preamplifier Agilent	8447D	2944A10633	Oct. 29, 2011	Oct. 28, 2012
Preamplifier Agilent	8449B	3008A01964	Oct. 29, 2011	Oct. 28, 2012
RF signal cable HUBER+SUHNNER	SUCOFLEX 104	250723/4	Aug. 30, 2011	Aug. 29, 2012
RF signal cable HUBER+SUHNNER	SUCOFLEX 106	12738/6+309224/4	Aug. 30, 2011	Aug. 29, 2012
Software ADT.	ADT_Radiated_ V7.6.15.9.2	NA	NA	NA
Antenna Tower inn-co GmbH	MA 4000	013303	NA	NA
Antenna Tower Controller inn-co GmbH	CO2000	017303	NA	NA
Turn Table ADT.	TT100	TT93021703	NA	NA
Turn Table Controller ADT.	SC100	SC93021703	NA	NA
26GHz ~ 40GHz Amplifier	EM26400	815221	Oct. 29, 2011	Oct. 28, 2012
High Speed Peak Power Meter	ML2495A	0842014	Apr. 26, 2011	Apr. 25, 2012
Power Sensor	MA2411B	0738404	Apr. 26, 2011	Apr. 25, 2012

- NOTE:**
1. The calibration interval of the above test instruments is 12 months and the calibrations are traceable to NML/ROC and NIST/USA.
 2. The test was performed in HwaYa Chamber 3.
 3. The horn antenna and HP preamplifier (model: 8449B) are used only for the measurement of emission frequency above 1GHz if tested.
 4. The FCC Site Registration No. is 988962.
 5. The IC Site Registration No. is IC 7450F-3.

4.1.3 TEST PROCEDURES

- a. The EUT was placed on the top of a rotating table 0.8 meters above the ground at a 3 meters semi-anechoic chamber. The table was rotated 360 degrees to determine the position of the highest radiation.
- b. The EUT was set 3 meters away from the interference-receiving antenna, which was mounted on the top of a variable-height antenna tower.
- c. The antenna is a broadband antenna, and its height is varied from one meter to four meters above the ground to determine the maximum value of the field strength. Both horizontal and vertical polarizations of the antenna are set to make the measurement.
- d. For each suspected emission, the EUT was arranged to its worst case and then the antenna was tuned to heights from 1 meter to 4 meters and the rotatable table was turned from 0 degrees to 360 degrees to find the maximum reading.
- e. The test-receiver system was set to Peak Detect Function and Specified Bandwidth with Maximum Hold Mode.
- f. If the emission level of the EUT in peak mode was lower than the limit specified, then testing could be stopped and the peak values of the EUT would be reported. Otherwise the emissions would be re-tested one by one using peak, quasi-peak or average method as specified and then reported in a data sheet.

NOTE:

1. The resolution bandwidth and video bandwidth of test receiver/spectrum analyzer is 120kHz for Quasi-peak detection at frequency below 1GHz.
2. The resolution bandwidth of test receiver/spectrum analyzer is 100kHz and video bandwidth is 300kHz for Peak detection at frequency above 1GHz.
3. The resolution bandwidth of test receiver/spectrum analyzer is 1MHz and the video bandwidth is 1kHz for Average detection (AV) at frequency above 1GHz.
4. All modes of operation were investigated and the worst-case emissions are reported.

4.1.4 DEVIATION FROM TEST STANDARD

No deviation.

4.1.5 TEST SETUP

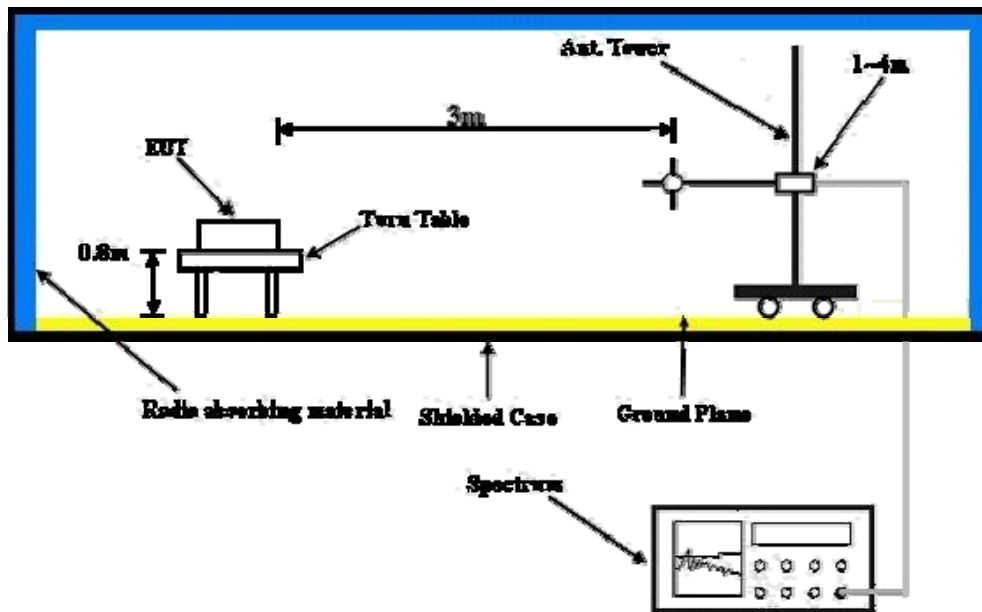

For the actual test configuration, please refer to the attached file (Test Setup Photo).

4.1.6 EUT OPERATING CONDITIONS

- a. Placed the EUT on the testing table.
- b. Prepared notebooks to act as communication partners and placed them outside of testing area.
- c. The communication partners connected with EUT via RJ45 cables and run a test program (provided by manufacturer) to enable EUT under transmission condition continuously at specific channel frequency.
- d. The communication partner sent data to EUT by command "PING".
- e. The communication partner read and wrote with the dongle via EUT.

4.1.7 TEST RESULTS

ABOVE 1GHz DATA: 802.11b

EUT TEST CONDITION		MEASUREMENT DETAIL	
CHANNEL	Channel 1	FREQUENCY RANGE	1 ~ 25GHz
INPUT POWER (SYSTEM)	120Vac, 60 Hz	DETECTOR FUNCTION	Peak (PK) Average (AV)
ENVIRONMENTAL CONDITIONS	25deg. C, 65%RH	TESTED BY	Aska Huang

ANTENNA POLARITY & TEST DISTANCE: HORIZONTAL AT 3 M								
NO.	FREQ. (MHz)	EMISSION LEVEL (dBuV/m)	LIMIT (dBuV/m)	MARGIN (dB)	ANTENNA HEIGHT (m)	TABLE ANGLE (Degree)	RAW VALUE (dBuV)	CORRECTION FACTOR (dB/m)
1	2390.00	53.5 PK	74.0	-20.5	1.00 H	43	22.20	31.30
2	2390.00	41.4 AV	54.0	-12.6	1.00 H	43	10.10	31.30
3	*2412.00	93.9 PK			1.00 H	43	62.50	31.40
4	*2412.00	90.3 AV			1.00 H	43	58.90	31.40
5	4824.00	53.0 PK	74.0	-21.0	1.08 H	347	15.80	37.20
6	4824.00	49.1 AV	54.0	-4.9	1.08 H	347	11.90	37.20
ANTENNA POLARITY & TEST DISTANCE: VERTICAL AT 3 M								
NO.	FREQ. (MHz)	EMISSION LEVEL (dBuV/m)	LIMIT (dBuV/m)	MARGIN (dB)	ANTENNA HEIGHT (m)	TABLE ANGLE (Degree)	RAW VALUE (dBuV)	CORRECTION FACTOR (dB/m)
1	2390.00	55.6 PK	74.0	-18.4	1.00 V	11	24.30	31.30
2	2390.00	44.2 AV	54.0	-9.8	1.00 V	11	12.90	31.30
3	*2412.00	104.9 PK			1.00 V	11	73.50	31.40
4	*2412.00	101.1 AV			1.00 V	11	69.70	31.40
5	4824.00	55.4 PK	74.0	-18.6	1.03 V	43	18.20	37.20
6	4824.00	52.8 AV	54.0	-1.2	1.03 V	43	15.60	37.20

REMARKS:

1. Emission level (dBuV/m) = Raw Value (dBuV) + Correction Factor (dB/m).
2. Correction Factor (dB/m) = Antenna Factor (dB/m) + Cable Factor (dB).
3. The other emission levels were very low against the limit.
4. Margin value = Emission level – Limit value.
5. “ * ”: Fundamental frequency.



A D T

EUT TEST CONDITION		MEASUREMENT DETAIL	
CHANNEL	Channel 6	FREQUENCY RANGE	1 ~ 25GHz
INPUT POWER (SYSTEM)	120Vac, 60 Hz	DETECTOR FUNCTION	Peak (PK) Average (AV)
ENVIRONMENTAL CONDITIONS	25deg. C, 65%RH	TESTED BY	Aska Huang

ANTENNA POLARITY & TEST DISTANCE: HORIZONTAL AT 3 M								
NO.	FREQ. (MHz)	EMISSION LEVEL (dBuV/m)	LIMIT (dBuV/m)	MARGIN (dB)	ANTENNA HEIGHT (m)	TABLE ANGLE (Degree)	RAW VALUE (dBuV)	CORRECTION FACTOR (dB/m)
1	*2437.00	94.0 PK			1.24 H	40	62.50	31.50
2	*2437.00	90.1 AV			1.24 H	40	58.60	31.50
3	4874.00	52.1 PK	74.0	-21.9	1.09 H	0	14.80	37.30
4	4874.00	48.2 AV	54.0	-5.8	1.09 H	0	10.90	37.30
5	7311.00	50.8 PK	74.0	-23.2	1.00 H	126	7.30	43.50
6	7311.00	37.2 AV	54.0	-16.8	1.00 H	126	-6.30	43.50
ANTENNA POLARITY & TEST DISTANCE: VERTICAL AT 3 M								
NO.	FREQ. (MHz)	EMISSION LEVEL (dBuV/m)	LIMIT (dBuV/m)	MARGIN (dB)	ANTENNA HEIGHT (m)	TABLE ANGLE (Degree)	RAW VALUE (dBuV)	CORRECTION FACTOR (dB/m)
1	*2437.00	106.2 PK			1.00 V	337	74.70	31.50
2	*2437.00	102.2 AV			1.00 V	337	70.70	31.50
3	4874.00	55.4 PK	74.0	-18.6	1.01 V	43	18.10	37.30
4	4874.00	52.8 AV	54.0	-1.2	1.01 V	43	15.50	37.30
5	7311.00	51.4 PK	74.0	-22.6	1.00 V	128	7.90	43.50
6	7311.00	37.7 AV	54.0	-16.3	1.00 V	128	-5.80	43.50

REMARKS:

1. Emission level (dBuV/m) = Raw Value (dBuV) + Correction Factor (dB/m).
2. Correction Factor (dB/m) = Antenna Factor (dB/m) + Cable Factor (dB).
3. The other emission levels were very low against the limit.
4. Margin value = Emission level – Limit value.
5. “ * “: Fundamental frequency.

EUT TEST CONDITION		MEASUREMENT DETAIL	
CHANNEL	Channel 11	FREQUENCY RANGE	1 ~ 25GHz
INPUT POWER (SYSTEM)	120Vac, 60 Hz	DETECTOR FUNCTION	Peak (PK) Average (AV)
ENVIRONMENTAL CONDITIONS	25deg. C, 65%RH	TESTED BY	Aska Huang

ANTENNA POLARITY & TEST DISTANCE: HORIZONTAL AT 3 M								
NO.	FREQ. (MHz)	EMISSION LEVEL (dBuV/m)	LIMIT (dBuV/m)	MARGIN (dB)	ANTENNA HEIGHT (m)	TABLE ANGLE (Degree)	RAW VALUE (dBuV)	CORRECTION FACTOR (dB/m)
1	*2462.00	93.5 PK			1.00 H	40	61.90	31.60
2	*2462.00	89.8 AV			1.00 H	40	58.20	31.60
3	2483.50	53.4 PK	74.0	-20.6	1.00 H	40	21.80	31.60
4	2483.50	41.7 AV	54.0	-12.3	1.00 H	40	10.10	31.60
5	4924.00	52.7 PK	74.0	-21.3	1.07 H	0	15.30	37.40
6	4924.00	48.4 AV	54.0	-5.6	1.07 H	0	11.00	37.40
ANTENNA POLARITY & TEST DISTANCE: VERTICAL AT 3 M								
NO.	FREQ. (MHz)	EMISSION LEVEL (dBuV/m)	LIMIT (dBuV/m)	MARGIN (dB)	ANTENNA HEIGHT (m)	TABLE ANGLE (Degree)	RAW VALUE (dBuV)	CORRECTION FACTOR (dB/m)
1	*2462.00	105.2 PK			1.00 V	12	73.60	31.60
2	*2462.00	101.5 AV			1.00 V	12	69.90	31.60
3	2483.50	55.1 PK	74.0	-18.9	1.00 V	12	23.50	31.60
4	2483.50	42.5 AV	54.0	-11.5	1.00 V	12	10.90	31.60
5	4924.00	55.0 PK	74.0	-19.0	1.02 V	6	17.60	37.40
6	4924.00	52.7 AV	54.0	-1.3	1.02 V	6	15.30	37.40

REMARKS:

1. Emission level (dBuV/m) = Raw Value (dBuV) + Correction Factor (dB/m).
2. Correction Factor (dB/m) = Antenna Factor (dB/m) + Cable Factor (dB).
3. The other emission levels were very low against the limit.
4. Margin value = Emission level – Limit value.
5. “ * “: Fundamental frequency.

802.11g

EUT TEST CONDITION		MEASUREMENT DETAIL	
CHANNEL	Channel 1	FREQUENCY RANGE	1 ~ 25GHz
INPUT POWER (SYSTEM)	120Vac, 60 Hz	DETECTOR FUNCTION	Peak (PK) Average (AV)
ENVIRONMENTAL CONDITIONS	25deg. C, 65%RH	TESTED BY	Aska Huang

ANTENNA POLARITY & TEST DISTANCE: HORIZONTAL AT 3 M								
NO.	FREQ. (MHz)	EMISSION LEVEL (dBuV/m)	LIMIT (dBuV/m)	MARGIN (dB)	ANTENNA HEIGHT (m)	TABLE ANGLE (Degree)	RAW VALUE (dBuV)	CORRECTION FACTOR (dB/m)
1	2390.00	57.6 PK	74.0	-16.4	1.00 H	44	26.30	31.30
2	2390.00	45.6 AV	54.0	-8.4	1.00 H	44	14.30	31.30
3	*2412.00	98.9 PK			1.00 H	44	67.50	31.40
4	*2412.00	89.3 AV			1.00 H	44	57.90	31.40
5	4824.00	57.2 PK	74.0	-16.8	1.00 H	0	20.00	37.20
6	4824.00	42.0 AV	54.0	-12.0	1.00 H	0	4.80	37.20

ANTENNA POLARITY & TEST DISTANCE: VERTICAL AT 3 M								
NO.	FREQ. (MHz)	EMISSION LEVEL (dBuV/m)	LIMIT (dBuV/m)	MARGIN (dB)	ANTENNA HEIGHT (m)	TABLE ANGLE (Degree)	RAW VALUE (dBuV)	CORRECTION FACTOR (dB/m)
1	2390.00	70.0 PK	74.0	-4.0	1.00 V	39	38.70	31.30
2	2390.00	52.8 AV	54.0	-1.2	1.00 V	39	21.50	31.30
3	*2412.00	110.1 PK			1.00 V	21	78.70	31.40
4	*2412.00	100.1 AV			1.00 V	21	68.70	31.40
5	4824.00	59.9 PK	74.0	-14.1	1.15 V	35	22.70	37.20
6	4824.00	45.0 AV	54.0	-9.0	1.15 V	35	7.80	37.20

REMARKS:

1. Emission level (dBuV/m) = Raw Value (dBuV) + Correction Factor (dB/m).
2. Correction Factor (dB/m) = Antenna Factor (dB/m) + Cable Factor (dB).
3. The other emission levels were very low against the limit.
4. Margin value = Emission level – Limit value.
5. “ * “: Fundamental frequency.



EUT TEST CONDITION		MEASUREMENT DETAIL	
CHANNEL	Channel 6	FREQUENCY RANGE	1 ~ 25GHz
INPUT POWER (SYSTEM)	120Vac, 60 Hz	DETECTOR FUNCTION	Peak (PK) Average (AV)
ENVIRONMENTAL CONDITIONS	25deg. C, 65%RH	TESTED BY	Aska Huang

ANTENNA POLARITY & TEST DISTANCE: HORIZONTAL AT 3 M								
NO.	FREQ. (MHz)	EMISSION LEVEL (dBuV/m)	LIMIT (dBuV/m)	MARGIN (dB)	ANTENNA HEIGHT (m)	TABLE ANGLE (Degree)	RAW VALUE (dBuV)	CORRECTION FACTOR (dB/m)
1	2386.00	55.4 PK	74.0	-18.6	1.00 H	39	24.10	31.30
2	2386.00	45.3 AV	54.0	-8.7	1.00 H	39	14.00	31.30
3	*2437.00	98.8 PK			1.00 H	39	67.30	31.50
4	*2437.00	88.9 AV			1.00 H	39	57.40	31.50
5	4874.00	57.4 PK	74.0	-16.6	1.08 H	0	20.10	37.30
6	4874.00	43.0 AV	54.0	-11.0	1.08 H	0	5.70	37.30
ANTENNA POLARITY & TEST DISTANCE: VERTICAL AT 3 M								
NO.	FREQ. (MHz)	EMISSION LEVEL (dBuV/m)	LIMIT (dBuV/m)	MARGIN (dB)	ANTENNA HEIGHT (m)	TABLE ANGLE (Degree)	RAW VALUE (dBuV)	CORRECTION FACTOR (dB/m)
1	2386.00	62.4 PK	74.0	-11.6	1.00 V	140	31.10	31.30
2	2386.00	52.7 AV	54.0	-1.3	1.00 V	140	21.40	31.30
3	*2437.00	111.8 PK			1.00 V	333	80.30	31.50
4	*2437.00	102.3 AV			1.00 V	333	70.80	31.50
5	4874.00	60.5 PK	74.0	-13.5	1.01 V	44	23.20	37.30
6	4874.00	46.8 AV	54.0	-7.2	1.01 V	44	9.50	37.30

REMARKS:

1. Emission level (dBuV/m) = Raw Value (dBuV) + Correction Factor (dB/m).
2. Correction Factor (dB/m) = Antenna Factor (dB/m) + Cable Factor (dB).
3. The other emission levels were very low against the limit.
4. Margin value = Emission level – Limit value.
5. “ * “: Fundamental frequency.



EUT TEST CONDITION		MEASUREMENT DETAIL	
CHANNEL	Channel 11	FREQUENCY RANGE	1 ~ 25GHz
INPUT POWER (SYSTEM)	120Vac, 60 Hz	DETECTOR FUNCTION	Peak (PK) Average (AV)
ENVIRONMENTAL CONDITIONS	25deg. C, 65%RH	TESTED BY	Aska Huang

ANTENNA POLARITY & TEST DISTANCE: HORIZONTAL AT 3 M								
NO.	FREQ. (MHz)	EMISSION LEVEL (dBuV/m)	LIMIT (dBuV/m)	MARGIN (dB)	ANTENNA HEIGHT (m)	TABLE ANGLE (Degree)	RAW VALUE (dBuV)	CORRECTION FACTOR (dB/m)
1	*2462.00	96.9 PK			1.00 H	40	65.30	31.60
2	*2462.00	87.3 AV			1.00 H	40	55.70	31.60
3	2483.50	62.3 PK	74.0	-11.7	1.00 H	40	30.70	31.60
4	2483.50	46.4 AV	54.0	-7.6	1.00 H	40	14.80	31.60
5	4924.00	53.0 PK	74.0	-21.0	1.08 H	0	15.60	37.40
6	4924.00	39.3 AV	54.0	-14.7	1.08 H	0	1.90	37.40
ANTENNA POLARITY & TEST DISTANCE: VERTICAL AT 3 M								
NO.	FREQ. (MHz)	EMISSION LEVEL (dBuV/m)	LIMIT (dBuV/m)	MARGIN (dB)	ANTENNA HEIGHT (m)	TABLE ANGLE (Degree)	RAW VALUE (dBuV)	CORRECTION FACTOR (dB/m)
1	*2462.00	108.5 PK			1.00 V	13	76.90	31.60
2	*2462.00	98.8 AV			1.00 V	13	67.20	31.60
3	2483.50	72.5 PK	74.0	-1.5	1.00 V	18	40.90	31.60
4	2483.50	53.0 AV	54.0	-1.0	1.00 V	18	21.40	31.60
5	4924.00	55.0 PK	74.0	-19.0	1.00 V	42	17.60	37.40
6	4924.00	41.9 AV	54.0	-12.1	1.00 V	42	4.50	37.40

REMARKS:

1. Emission level (dBuV/m) = Raw Value (dBuV) + Correction Factor (dB/m).
2. Correction Factor (dB/m) = Antenna Factor (dB/m) + Cable Factor (dB).
3. The other emission levels were very low against the limit.
4. Margin value = Emission level – Limit value.
5. “ * “: Fundamental frequency.



A D T

802.11n (20MHz)

EUT TEST CONDITION		MEASUREMENT DETAIL	
CHANNEL	Channel 1	FREQUENCY RANGE	1 ~ 25GHz
INPUT POWER (SYSTEM)	120Vac, 60 Hz	DETECTOR FUNCTION	Peak (PK) Average (AV)
ENVIRONMENTAL CONDITIONS	25deg. C, 65%RH	TESTED BY	Aska Huang

ANTENNA POLARITY & TEST DISTANCE: HORIZONTAL AT 3 M								
NO.	FREQ. (MHz)	EMISSION LEVEL (dBuV/m)	LIMIT (dBuV/m)	MARGIN (dB)	ANTENNA HEIGHT (m)	TABLE ANGLE (Degree)	RAW VALUE (dBuV)	CORRECTION FACTOR (dB/m)
1	2360.00	54.4 PK	74.0	-19.6	1.00 H	207	23.20	31.20
2	2360.00	45.9 AV	54.0	-8.1	1.00 H	207	14.70	31.20
3	2390.00	57.4 PK	74.0	-16.6	1.00 H	207	26.10	31.30
4	2390.00	46.4 AV	54.0	-7.6	1.00 H	207	15.10	31.30
5	*2412.00	99.2 PK			1.00 H	207	67.80	31.40
6	*2412.00	87.3 AV			1.00 H	207	55.90	31.40
7	4824.00	49.2 PK	74.0	-24.8	1.22 H	0	12.00	37.20
8	4824.00	37.1 AV	54.0	-16.9	1.22 H	0	-0.10	37.20
ANTENNA POLARITY & TEST DISTANCE: VERTICAL AT 3 M								
NO.	FREQ. (MHz)	EMISSION LEVEL (dBuV/m)	LIMIT (dBuV/m)	MARGIN (dB)	ANTENNA HEIGHT (m)	TABLE ANGLE (Degree)	RAW VALUE (dBuV)	CORRECTION FACTOR (dB/m)
1	2360.00	62.4 PK	74.0	-11.6	1.00 V	193	31.20	31.20
2	2360.00	51.6 AV	54.0	-2.4	1.00 V	193	20.40	31.20
3	2390.00	64.9 PK	74.0	-9.1	1.00 V	193	33.60	31.30
4	2390.00	52.5 AV	54.0	-1.5	1.00 V	193	21.20	31.30
5	*2412.00	111.3 PK			1.00 V	332	79.90	31.40
6	*2412.00	99.6 AV			1.00 V	332	68.20	31.40
7	4824.00	49.4 PK	74.0	-24.6	1.00 V	302	12.20	37.20
8	4824.00	36.5 AV	54.0	-17.5	1.00 V	302	-0.70	37.20

REMARKS:

1. Emission level (dBuV/m) = Raw Value (dBuV) + Correction Factor (dB/m).
2. Correction Factor (dB/m) = Antenna Factor (dB/m) + Cable Factor (dB).
3. The other emission levels were very low against the limit.
4. Margin value = Emission level – Limit value.
5. “ * “: Fundamental frequency.



EUT TEST CONDITION		MEASUREMENT DETAIL	
CHANNEL	Channel 6	FREQUENCY RANGE	1 ~ 25GHz
INPUT POWER (SYSTEM)	120Vac, 60 Hz	DETECTOR FUNCTION	Peak (PK) Average (AV)
ENVIRONMENTAL CONDITIONS	25deg. C, 65%RH	TESTED BY	Aska Huang

ANTENNA POLARITY & TEST DISTANCE: HORIZONTAL AT 3 M								
NO.	FREQ. (MHz)	EMISSION LEVEL (dBuV/m)	LIMIT (dBuV/m)	MARGIN (dB)	ANTENNA HEIGHT (m)	TABLE ANGLE (Degree)	RAW VALUE (dBuV)	CORRECTION FACTOR (dB/m)
1	2386.00	54.7 PK	74.0	-19.3	1.21 H	204	23.40	31.30
2	2386.00	45.1 AV	54.0	-8.9	1.21 H	204	13.80	31.30
3	*2437.00	96.6 PK			1.21 H	204	65.10	31.50
4	*2437.00	85.2 AV			1.21 H	204	53.70	31.50
5	2489.00	55.9 PK	74.0	-18.1	1.21 H	204	24.20	31.70
6	2489.00	44.8 AV	54.0	-9.2	1.21 H	204	13.10	31.70
7	4874.00	49.6 PK	74.0	-24.4	1.08 H	343	12.30	37.30
8	4874.00	36.6 AV	54.0	-17.4	1.08 H	343	-0.70	37.30
ANTENNA POLARITY & TEST DISTANCE: VERTICAL AT 3 M								
NO.	FREQ. (MHz)	EMISSION LEVEL (dBuV/m)	LIMIT (dBuV/m)	MARGIN (dB)	ANTENNA HEIGHT (m)	TABLE ANGLE (Degree)	RAW VALUE (dBuV)	CORRECTION FACTOR (dB/m)
1	2386.00	64.2 PK	74.0	-9.8	1.19 V	204	32.90	31.30
2	2386.00	53.0 AV	54.0	-1.0	1.19 V	204	21.70	31.30
3	*2437.00	109.4 PK			1.00 V	333	77.90	31.50
4	*2437.00	98.6 AV			1.00 V	333	67.10	31.50
5	2489.00	65.4 PK	74.0	-8.6	1.35 V	204	33.70	31.70
6	2489.00	52.9 AV	54.0	-1.1	1.35 V	204	21.20	31.70
7	4874.00	48.8 PK	74.0	-25.2	1.00 V	44	11.50	37.30
8	4874.00	36.5 AV	54.0	-17.5	1.00 V	44	-0.80	37.30

REMARKS:

1. Emission level (dBuV/m) = Raw Value (dBuV) + Correction Factor (dB/m).
2. Correction Factor (dB/m) = Antenna Factor (dB/m) + Cable Factor (dB).
3. The other emission levels were very low against the limit.
4. Margin value = Emission level – Limit value.
5. “ * “: Fundamental frequency.

EUT TEST CONDITION		MEASUREMENT DETAIL	
CHANNEL	Channel 11	FREQUENCY RANGE	1 ~ 25GHz
INPUT POWER (SYSTEM)	120Vac, 60 Hz	DETECTOR FUNCTION	Peak (PK) Average (AV)
ENVIRONMENTAL CONDITIONS	25deg. C, 65%RH	TESTED BY	Aska Huang

ANTENNA POLARITY & TEST DISTANCE: HORIZONTAL AT 3 M								
NO.	FREQ. (MHz)	EMISSION LEVEL (dBuV/m)	LIMIT (dBuV/m)	MARGIN (dB)	ANTENNA HEIGHT (m)	TABLE ANGLE (Degree)	RAW VALUE (dBuV)	CORRECTION FACTOR (dB/m)
1	*2462.00	96.5 PK			1.00 H	37	64.90	31.60
2	*2462.00	86.7 AV			1.00 H	37	55.10	31.60
3	2483.50	56.0 PK	74.0	-18.0	1.00 H	37	24.40	31.60
4	2483.50	44.6 AV	54.0	-9.4	1.00 H	37	13.00	31.60
5	4924.00	50.2 PK	74.0	-23.8	1.07 H	0	12.80	37.40
6	4924.00	37.2 AV	54.0	-16.8	1.07 H	0	-0.20	37.40
ANTENNA POLARITY & TEST DISTANCE: VERTICAL AT 3 M								
NO.	FREQ. (MHz)	EMISSION LEVEL (dBuV/m)	LIMIT (dBuV/m)	MARGIN (dB)	ANTENNA HEIGHT (m)	TABLE ANGLE (Degree)	RAW VALUE (dBuV)	CORRECTION FACTOR (dB/m)
1	*2462.00	109.9 PK			1.00 V	332	78.30	31.60
2	*2462.00	98.8 AV			1.00 V	332	67.20	31.60
3	2483.50	65.0 PK	74.0	-9.0	1.00 V	329	33.40	31.60
4	2483.50	52.8 AV	54.0	-1.2	1.00 V	329	21.20	31.60
5	4924.00	52.8 PK	74.0	-21.2	1.00 V	44	15.40	37.40
6	4924.00	38.9 AV	54.0	-15.1	1.00 V	44	1.50	37.40

REMARKS:

1. Emission level (dBuV/m) = Raw Value (dBuV) + Correction Factor (dB/m).
2. Correction Factor (dB/m) = Antenna Factor (dB/m) + Cable Factor (dB).
3. The other emission levels were very low against the limit.
4. Margin value = Emission level – Limit value.
5. “ * “: Fundamental frequency.



802.11n (40MHz)

EUT TEST CONDITION		MEASUREMENT DETAIL	
CHANNEL	Channel 3	FREQUENCY RANGE	1 ~ 25GHz
INPUT POWER (SYSTEM)	120Vac, 60 Hz	DETECTOR FUNCTION	Peak (PK) Average (AV)
ENVIRONMENTAL CONDITIONS	25deg. C, 65%RH	TESTED BY	Aska Huang

ANTENNA POLARITY & TEST DISTANCE: HORIZONTAL AT 3 M								
NO.	FREQ. (MHz)	EMISSION LEVEL (dBuV/m)	LIMIT (dBuV/m)	MARGIN (dB)	ANTENNA HEIGHT (m)	TABLE ANGLE (Degree)	RAW VALUE (dBuV)	CORRECTION FACTOR (dB/m)
1	2390.00	57.5 PK	74.0	-16.5	1.00 H	206	26.20	31.30
2	2390.00	46.5 AV	54.0	-7.5	1.00 H	206	15.20	31.30
3	*2422.00	94.8 PK			1.00 H	206	63.40	31.40
4	*2422.00	83.6 AV			1.00 H	206	52.20	31.40
5	4844.00	46.5 PK	74.0	-27.5	1.10 H	0	9.20	37.30
6	4844.00	34.5 AV	54.0	-19.5	1.10 H	0	-2.80	37.30
ANTENNA POLARITY & TEST DISTANCE: VERTICAL AT 3 M								
NO.	FREQ. (MHz)	EMISSION LEVEL (dBuV/m)	LIMIT (dBuV/m)	MARGIN (dB)	ANTENNA HEIGHT (m)	TABLE ANGLE (Degree)	RAW VALUE (dBuV)	CORRECTION FACTOR (dB/m)
1	2390.00	65.4 PK	74.0	-8.6	1.00 V	196	34.10	31.30
2	2390.00	53.0 AV	54.0	-1.0	1.00 V	196	21.70	31.30
3	*2422.00	105.5 PK			1.00 V	330	74.10	31.40
4	*2422.00	94.7 AV			1.00 V	330	63.30	31.40
5	4844.00	46.8 PK	74.0	-27.2	1.02 V	44	9.50	37.30
6	4844.00	34.4 AV	54.0	-19.6	1.02 V	44	-2.90	37.30

REMARKS:

1. Emission level (dBuV/m) = Raw Value (dBuV) + Correction Factor (dB/m).
2. Correction Factor (dB/m) = Antenna Factor (dB/m) + Cable Factor (dB).
3. The other emission levels were very low against the limit.
4. Margin value = Emission level – Limit value.
5. “ * “: Fundamental frequency.



A D T

EUT TEST CONDITION		MEASUREMENT DETAIL	
CHANNEL	Channel 6	FREQUENCY RANGE	1 ~ 25GHz
INPUT POWER (SYSTEM)	120Vac, 60 Hz	DETECTOR FUNCTION	Peak (PK) Average (AV)
ENVIRONMENTAL CONDITIONS	25deg. C, 65%RH	TESTED BY	Aska Huang

ANTENNA POLARITY & TEST DISTANCE: HORIZONTAL AT 3 M								
NO.	FREQ. (MHz)	EMISSION LEVEL (dBuV/m)	LIMIT (dBuV/m)	MARGIN (dB)	ANTENNA HEIGHT (m)	TABLE ANGLE (Degree)	RAW VALUE (dBuV)	CORRECTION FACTOR (dB/m)
1	*2437.00	96.0 PK			1.00 H	207	64.50	31.50
2	*2437.00	84.5 AV			1.00 H	207	53.00	31.50
3	2483.50	56.5 PK	74.0	-17.5	1.00 H	207	24.90	31.60
4	2483.50	44.9 AV	54.0	-9.1	1.00 H	207	13.30	31.60
5	4874.00	48.1 PK	74.0	-25.9	1.09 H	0	10.80	37.30
6	4874.00	35.6 AV	54.0	-18.4	1.09 H	0	-1.70	37.30
ANTENNA POLARITY & TEST DISTANCE: VERTICAL AT 3 M								
NO.	FREQ. (MHz)	EMISSION LEVEL (dBuV/m)	LIMIT (dBuV/m)	MARGIN (dB)	ANTENNA HEIGHT (m)	TABLE ANGLE (Degree)	RAW VALUE (dBuV)	CORRECTION FACTOR (dB/m)
1	*2437.00	109.6 PK			1.00 V	332	78.10	31.50
2	*2437.00	98.9 AV			1.00 V	332	67.40	31.50
3	2483.50	64.5 PK	74.0	-9.5	1.00 V	329	32.90	31.60
4	2483.50	52.8 AV	54.0	-1.2	1.00 V	329	21.20	31.60
5	4874.00	48.7 PK	74.0	-25.3	1.00 V	43	11.40	37.30
6	4874.00	36.4 AV	54.0	-17.6	1.00 V	43	-0.90	37.30

REMARKS:

1. Emission level (dBuV/m) = Raw Value (dBuV) + Correction Factor (dB/m).
2. Correction Factor (dB/m) = Antenna Factor (dB/m) + Cable Factor (dB).
3. The other emission levels were very low against the limit.
4. Margin value = Emission level – Limit value.
5. “ * “: Fundamental frequency.

EUT TEST CONDITION		MEASUREMENT DETAIL	
CHANNEL	Channel 9	FREQUENCY RANGE	1 ~ 25GHz
INPUT POWER (SYSTEM)	120Vac, 60 Hz	DETECTOR FUNCTION	Peak (PK) Average (AV)
ENVIRONMENTAL CONDITIONS	25deg. C, 65%RH	TESTED BY	Aska Huang

ANTENNA POLARITY & TEST DISTANCE: HORIZONTAL AT 3 M								
NO.	FREQ. (MHz)	EMISSION LEVEL (dBuV/m)	LIMIT (dBuV/m)	MARGIN (dB)	ANTENNA HEIGHT (m)	TABLE ANGLE (Degree)	RAW VALUE (dBuV)	CORRECTION FACTOR (dB/m)
1	*2452.00	94.2 PK			1.19 H	204	62.70	31.50
2	*2452.00	82.8 AV			1.19 H	204	51.30	31.50
3	2483.50	58.5 PK	74.0	-15.5	1.19 H	204	26.90	31.60
4	2483.50	45.5 AV	54.0	-8.5	1.19 H	204	13.90	31.60
5	4904.00	46.1 PK	74.0	-27.9	1.10 H	0	8.70	37.40
6	4904.00	35.2 AV	54.0	-18.8	1.10 H	0	-2.20	37.40
ANTENNA POLARITY & TEST DISTANCE: VERTICAL AT 3 M								
NO.	FREQ. (MHz)	EMISSION LEVEL (dBuV/m)	LIMIT (dBuV/m)	MARGIN (dB)	ANTENNA HEIGHT (m)	TABLE ANGLE (Degree)	RAW VALUE (dBuV)	CORRECTION FACTOR (dB/m)
1	*2452.00	104.8 PK			1.00 V	333	73.30	31.50
2	*2452.00	94.6 AV			1.00 V	333	63.10	31.50
3	2483.50	68.0 PK	74.0	-6.0	1.00 V	329	36.40	31.60
4	2483.50	52.8 AV	54.0	-1.2	1.00 V	329	21.20	31.60
5	4904.00	48.2 PK	74.0	-25.8	1.00 V	44	10.80	37.40
6	4904.00	34.2 AV	54.0	-19.8	1.00 V	44	-3.20	37.40

REMARKS:

1. Emission level (dBuV/m) = Raw Value (dBuV) + Correction Factor (dB/m).
2. Correction Factor (dB/m) = Antenna Factor (dB/m) + Cable Factor (dB).
3. The other emission levels were very low against the limit.
4. Margin value = Emission level – Limit value.
5. “ * “: Fundamental frequency.

BELOW 1GHz WORST-CASE DATA : 802.11n (20MHz)

EUT TEST CONDITION		MEASUREMENT DETAIL	
CHANNEL	Channel 11	FREQUENCY RANGE	Below 1000MHz
INPUT POWER (SYSTEM)	120Vac, 60 Hz	DETECTOR FUNCTION	Quasi-Peak
ENVIRONMENTAL CONDITIONS	25deg. C, 65%RH	TESTED BY	Aska Huang

ANTENNA POLARITY & TEST DISTANCE: HORIZONTAL AT 3 M								
NO.	FREQ. (MHz)	EMISSION LEVEL (dBuV/m)	LIMIT (dBuV/m)	MARGIN (dB)	ANTENNA HEIGHT (m)	TABLE ANGLE (Degree)	RAW VALUE (dBuV)	CORRECTION FACTOR (dB/m)
1	88.23	40.6 QP	43.5	-2.9	1.99 H	15	32.10	8.50
2	125.17	39.2 QP	43.5	-4.3	1.49 H	101	26.90	12.30
3	166.00	35.8 QP	43.5	-7.7	1.24 H	32	22.00	13.80
4	374.04	40.0 QP	46.0	-6.0	1.00 H	54	23.10	16.90
5	502.36	41.0 QP	46.0	-5.0	1.24 H	208	21.00	20.00
6	624.85	39.6 QP	46.0	-6.4	1.24 H	13	17.30	22.30
ANTENNA POLARITY & TEST DISTANCE: VERTICAL AT 3 M								
NO.	FREQ. (MHz)	EMISSION LEVEL (dBuV/m)	LIMIT (dBuV/m)	MARGIN (dB)	ANTENNA HEIGHT (m)	TABLE ANGLE (Degree)	RAW VALUE (dBuV)	CORRECTION FACTOR (dB/m)
1	37.45	34.1 QP	40.0	-5.9	2.00 V	145	20.90	13.20
2	66.84	37.7 QP	40.0	-2.3	1.00 V	145	25.00	12.70
3	125.17	41.7 QP	43.5	-1.8	1.24 V	335	29.40	12.30
4	374.04	41.6 QP	46.0	-4.4	1.00 V	180	24.70	16.90
5	502.36	44.7 QP	46.0	-1.3	1.24 V	1	24.70	20.00
6	830.95	39.8 QP	46.0	-6.2	1.50 V	249	13.80	26.00

REMARKS:

1. Emission level (dBuV/m) = Raw Value (dBuV) + Correction Factor (dB/m).
2. Correction Factor (dB/m) = Antenna Factor (dB/m) + Cable Factor (dB).
3. The other emission levels were very low against the limit.
4. Margin value = Emission level – Limit value.

4.2 CONDUCTED EMISSION MEASUREMENT

4.2.1 LIMITS OF CONDUCTED EMISSION MEASUREMENT

FREQUENCY OF EMISSION (MHz)	CONDUCTED LIMIT (dB μ V)	
	Quasi-peak	Average
0.15 ~ 0.5	66 to 56	56 to 46
0.5 ~ 5	56	46
5 ~ 30	60	50

- NOTE:** 1. The lower limit shall apply at the transition frequencies.
2. The limit decreases in line with the logarithm of the frequency in the range of 0.15 to 0.50MHz.
3. All emanations from a class A/B digital device or system, including any network of conductors and apparatus connected thereto, shall not exceed the level of field strengths specified above.

4.2.2 TEST INSTRUMENTS

DESCRIPTION & MANUFACTURER	MODEL NO.	SERIAL NO.	DATE OF CALIBRATION	DUE DATE OF CALIBRATION
Test Receiver ROHDE & SCHWARZ	ESCS30	100289	Nov. 19, 2011	Nov. 18, 2012
RF signal cable Woken	5D-FB	Cable-HYCO2-01	Dec. 22, 2011	Dec. 21, 2012
LISN ROHDE & SCHWARZ	ESH2-Z5	100100	Dec. 30, 2011	Dec. 29, 2012
LISN ROHDE & SCHWARZ	ESH3-Z5	100312	Jul. 07, 2011	Jul. 06, 2012
V-LISN SCHWARZBECK	NNBL 8226-2	8226-142	Jun. 30, 2011	Jun. 29, 2012
LISN ROHDE & SCHWARZ	ENV216	100072	Jun. 10, 2011	Jun. 09, 2012
Software ADT	ADT_Cond_ V7.3.7	NA	NA	NA

- NOTE:** 1. The calibration interval of the above test instruments is 12 months and the calibrations are traceable to NML/ROC and NIST/USA.
2. The test was performed in HwaYa Shielded Room 2.
3. The VCCI Site Registration No. is C-2047.

4.2.3 TEST PROCEDURES

- a. The EUT was placed 0.4 meters from the conducting wall of the shielded room with EUT being connected to the power mains through a line impedance stabilization network (LISN). Other support units were connected to the power mains through another LISN. The two LISNs provide 50 ohm/ 50uH of coupling impedance for the measuring instrument.
- b. Both lines of the power mains connected to the EUT were checked for maximum conducted interference.
- c. The frequency range from 150kHz to 30MHz was searched. Emission levels under (Limit - 20dB) was not recorded.

NOTE: All modes of operation were investigated and the worst-case emissions are reported.

4.2.4 DEVIATION FROM TEST STANDARD

No deviation.

4.2.5 TEST SETUP

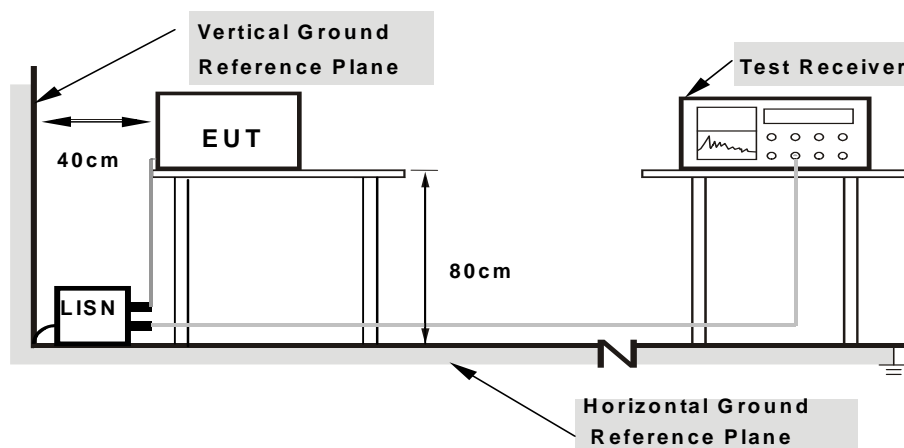

- Note:**
1. Support units were connected to second LISN.
 2. Both of LISNs (AMN) are 80 cm from EUT and at least 80 cm from other units and other metal planes

For the actual test configuration, please refer to the attached file (Test Setup Photo).

4.2.6 EUT OPERATING CONDITIONS

Same as 4.1.6.

4.2.7 TEST RESULTS

CONDUCTED WORST-CASE DATA : 802.11n (20MHz)

PHASE	Line 1	6dB BANDWIDTH	9kHz
-------	--------	---------------	------

No	Freq. [MHz]	Corr. Factor (dB)	Reading Value		Emission Level		Limit		Margin	
			[dB (uV)]		[dB (uV)]		[dB (uV)]		(dB)	
			Q.P.	AV.	Q.P.	AV.	Q.P.	AV.	Q.P.	AV.
1	0.19297	0.17	35.40	18.24	35.57	18.41	63.91	53.91	-28.34	-35.50
2	0.40391	0.20	34.33	24.49	34.53	24.69	57.77	47.77	-23.24	-23.08
3	2.15234	0.31	33.13	21.85	33.44	22.16	56.00	46.00	-22.56	-23.84
4	4.52344	0.40	34.68	26.43	35.08	26.83	56.00	46.00	-20.92	-19.17
5	7.77344	0.45	34.63	25.17	35.08	25.62	60.00	50.00	-24.92	-24.38
6	20.29297	0.73	34.76	28.05	35.49	28.78	60.00	50.00	-24.51	-21.22

- REMARKS:**
1. Q.P. and AV. are abbreviations of quasi-peak and average individually.
 2. The emission levels of other frequencies were very low against the limit.
 3. Margin value = Emission level - Limit value
 4. Correction factor = Insertion loss + Cable loss
 5. Emission Level = Correction Factor + Reading Value.

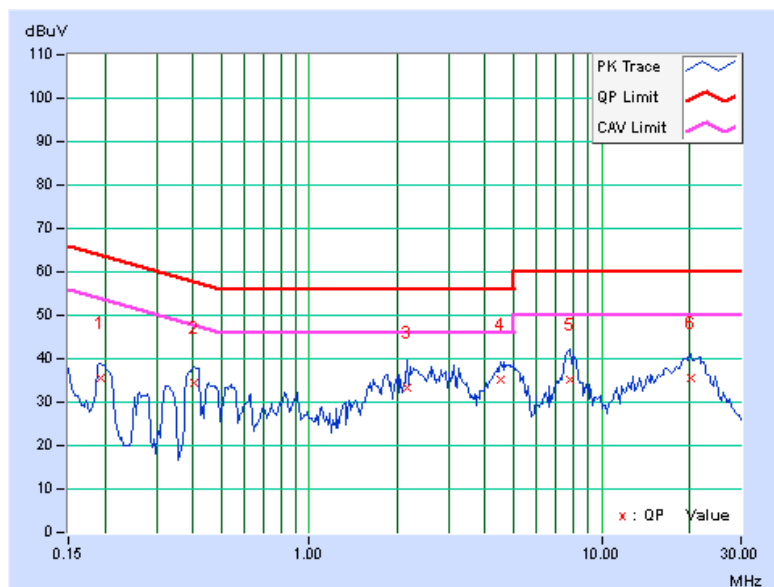

PHASE	Line 2	6dB BANDWIDTH	9kHz
-------	--------	---------------	------

No	Freq. [MHz]	Corr. Factor (dB)	Reading Value		Emission Level		Limit		Margin	
			[dB (uV)]		[dB (uV)]		[dB (uV)]		(dB)	
			Q.P.	AV.	Q.P.	AV.	Q.P.	AV.	Q.P.	AV.
1	0.19297	0.15	36.25	24.55	36.40	24.70	63.91	53.91	-27.50	-29.20
2	0.38828	0.18	37.61	27.04	37.79	27.22	58.10	48.10	-20.31	-20.88
3	2.22656	0.28	35.82	22.45	36.10	22.73	56.00	46.00	-19.90	-23.27
4	4.50391	0.40	36.16	27.43	36.56	27.83	56.00	46.00	-19.44	-18.17
5	7.82813	0.50	34.85	24.90	35.35	25.40	60.00	50.00	-24.65	-24.60
6	21.15625	0.80	34.13	27.27	34.93	28.07	60.00	50.00	-25.07	-21.93

- REMARKS:**
1. Q.P. and AV. are abbreviations of quasi-peak and average individually.
 2. The emission levels of other frequencies were very low against the limit.
 3. Margin value = Emission level - Limit value
 4. Correction factor = Insertion loss + Cable loss
 5. Emission Level = Correction Factor + Reading Value.

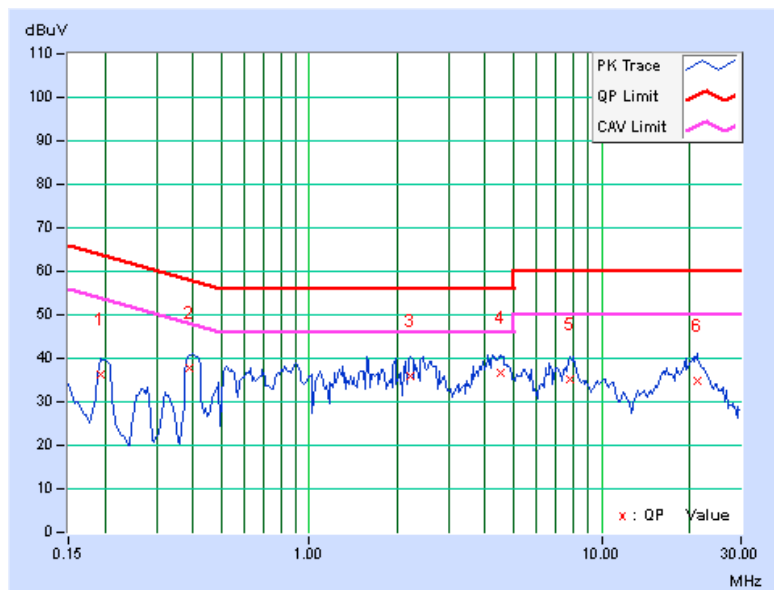

4.3 6dB BANDWIDTH MEASUREMENT

4.3.1 LIMITS OF 6dB BANDWIDTH MEASUREMENT

The minimum of 6dB Bandwidth Measurement is 0.5 MHz.

4.3.2 TEST SETUP

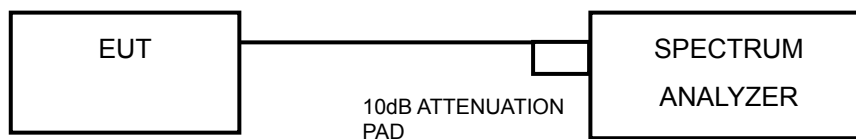

4.3.3 TEST INSTRUMENTS

Refer to section 4.1.2 to get information of above instrument.

4.3.4 TEST PROCEDURE

- a. Set resolution bandwidth (RBW) = approximately 1% of the emission bandwidth
- b. Set the video bandwidth (VBW) $\geq 3 \times$ RBW, Detector = Peak.
- c. Trace mode = max hold.
- d. Sweep = auto couple.
- e. Measure the maximum width of the emission that is constrained by the frequencies associated with the two amplitude points (upper and lower) that are attenuated by 6 dB relative to the maximum level measured in the fundamental emission

4.3.5 DEVIATION FROM TEST STANDARD

No deviation.

4.3.6 EUT OPERATING CONDITIONS

The software provided by client to enable the EUT under transmission condition continuously at lowest, middle and highest channel frequencies individually.

4.3.7 TEST RESULTS

802.11b

CHANNEL	FREQUENCY (MHz)	6dB BANDWIDTH (MHz)	MINIMUM LIMIT (MHz)	PASS / FAIL
1	2412	10.41	0.5	PASS
6	2437	10.41	0.5	PASS
11	2462	10.41	0.5	PASS

802.11g

CHANNEL	FREQUENCY (MHz)	6dB BANDWIDTH (MHz)	MINIMUM LIMIT (MHz)	PASS / FAIL
1	2412	16.51	0.5	PASS
6	2437	16.46	0.5	PASS
11	2462	16.51	0.5	PASS

802.11n (20MHz)

CHANNEL	FREQUENCY (MHz)	6dB BANDWIDTH (MHz)		MINIMUM LIMIT (MHz)	PASS / FAIL
		CHAIN 0	CHAIN 1		
1	2412	17.55	17.49	0.5	PASS
6	2437	17.59	17.53	0.5	PASS
11	2462	17.57	17.53	0.5	PASS

802.11n (40MHz)

CHANNEL	FREQUENCY (MHz)	6dB BANDWIDTH (MHz)		MINIMUM LIMIT (MHz)	PASS / FAIL
		CHAIN 0	CHAIN 1		
3	2422	36.43	36.19	0.5	PASS
6	2437	36.37	36.18	0.5	PASS
9	2452	36.40	36.23	0.5	PASS

4.4 CONDUCTED OUTPUT POWER

4.4.1 LIMITS OF CONDUCTED OUTPUT POWER MEASUREMENT

For systems using digital modulation in the 2400–2483.5 MHz bands: 1 Watt (30dBm)

4.4.2 TEST SETUP

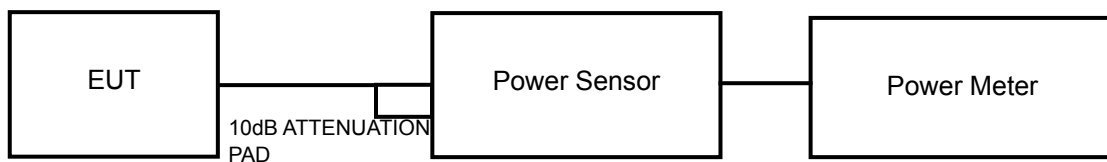

4.4.3 TEST INSTRUMENTS

Refer to section 4.1.2 to get information of above instrument.

4.4.4 TEST PROCEDURES

A peak power sensor was used on the output port of the EUT. A power meter was used to read the response of the peak power sensor. Record the peak power level.

4.4.5 DEVIATION FROM TEST STANDARD

No deviation.

4.4.6 EUT OPERATING CONDITIONS

Same as Item 4.3.6.

4.4.7 TEST RESULTS

802.11b

CHANNEL	FREQUENCY (MHz)	PEAK POWER (mW)	PEAK POWER (dBm)	LIMIT (dBm)	PASS/FAIL
1	2412	67.6	18.30	30	PASS
6	2437	66.2	18.21	30	PASS
11	2462	58.2	17.65	30	PASS

802.11g

CHANNEL	FREQUENCY (MHz)	PEAK POWER (mW)	PEAK POWER (dBm)	LIMIT (dBm)	PASS/FAIL
1	2412	367.3	25.65	30	PASS
6	2437	363.1	25.60	30	PASS
11	2462	273.5	24.37	30	PASS

802.11n (20MHz)

CHAN.	FREQUENCY (MHz)	PEAK POWER (dBm)		TOTAL POWER (mW)	TOTAL POWER (dBm)	LIMIT (dBm)	PASS / FAIL
		CHAIN 0	CHAIN 1				
1	2412	22.41	22.10	336.4	25.3	30	PASS
6	2437	21.82	21.61	296.9	24.7	30	PASS
11	2462	22.51	22.27	346.9	25.4	30	PASS

802.11n (40MHz)

CHAN.	FREQUENCY (MHz)	PEAK POWER (dBm)		TOTAL POWER (mW)	TOTAL POWER (dBm)	LIMIT (dBm)	PASS / FAIL
		CHAIN 0	CHAIN 1				
3	2422	21.18	21.01	257.4	24.1	30	PASS
6	2437	22.91	22.91	390.9	25.9	30	PASS
9	2452	20.61	20.84	236.4	23.7	30	PASS

4.5 POWER SPECTRAL DENSITY MEASUREMENT

4.5.1 LIMITS OF POWER SPECTRAL DENSITY MEASUREMENT

The Maximum of Power Spectral Density Measurement is 8dBm.

4.5.2 TEST SETUP

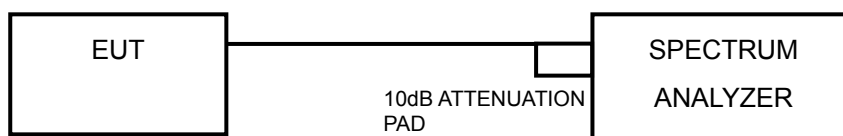

4.5.3 TEST INSTRUMENTS

Refer to section 4.1.2 to get information of above instrument.

4.5.4 TEST PROCEDURE

- a. Set the RBW = 100 kHz, VBW = 300 kHz, Detector = peak.
- b. Sweep time = auto couple, Trace mode = max hold, allow trace to fully stabilize.
- c. Use the peak marker function to determine the maximum power level in any 100 kHz band segment within the fundamental EBW.
- d. Scale the observed power level to an equivalent value in 3 kHz by adjusting (reducing) the measured power by a bandwidth correction factor (BWCF) where $BWCF = 10\log(3 \text{ kHz}/100\text{kHz})$

4.5.5 DEVIATION FROM TEST STANDARD

No deviation.

4.5.6 EUT OPERATING CONDITION

Same as Item 4.3.6

4.5.7 TEST RESULTS

802.11b

Channel	FREQ. (MHz)	PSD (dBm/100kHz)	PSD (dBm/3kHz)	Limit (dBm/3kHz)	PASS /FAIL
1	2412	4.66	-10.57	8	PASS
6	2437	4.32	-10.91	8	PASS
11	2462	3.85	-11.38	8	PASS

802.11g

Channel	FREQ. (MHz)	PSD (dBm/100kHz)	PSD (dBm/3kHz)	Limit (dBm/3kHz)	PASS /FAIL
1	2412	4.12	-11.11	8	PASS
6	2437	4.09	-11.14	8	PASS
11	2462	2.70	-12.53	8	PASS

802.11n (20MHz)

TX chain	Channel	FREQ. (MHz)	PSD (dBm/100kHz)	PSD (dBm/3kHz)	10 log (N=2) dB	Total PSD (dBm/3kHz)	Limit (dBm/3kHz)	PASS /FAIL
0	1	2412	-0.13	-15.36	3.01	-12.35	8	PASS
	6	2437	-0.73	-15.96	3.01	-12.95	8	PASS
	11	2462	0.03	-15.20	3.01	-12.19	8	PASS
1	1	2412	0.19	-15.04	3.01	-12.03	8	PASS
	6	2437	-0.10	-15.33	3.01	-12.32	8	PASS
	11	2462	0.49	-14.74	3.01	-11.73	8	PASS

802.11n (40MHz)

TX chain	Channel	FREQ. (MHz)	PSD (dBm/100kHz)	PSD (dBm/3kHz)	10 log (N=2) dB	Total PSD (dBm/3kHz)	Limit (dBm/3kHz)	PASS /FAIL
0	3	2422	-4.06	-19.29	3.01	-16.28	8	PASS
	6	2437	-2.36	-17.59	3.01	-14.58	8	PASS
	9	2452	-4.51	-19.74	3.01	-16.73	8	PASS
1	3	2422	-2.95	-18.18	3.01	-15.17	8	PASS
	6	2437	-1.05	-16.28	3.01	-13.27	8	PASS
	9	2452	-3.27	-18.50	3.01	-15.49	8	PASS

4.6 CONDUCTED OUT OF BAND EMISSION MEASUREMENT

4.6.1 LIMITS OF CONDUCTED OUT OF BAND EMISSION MEASUREMENT

Below -20dB of the highest emission level of operating band (in 100kHz Resolution Bandwidth).

4.6.2 TEST SETUP

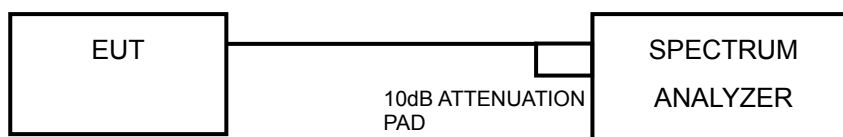

4.6.3 TEST INSTRUMENTS

Refer to section 4.1.2 to get information of above instrument.

4.6.4 TEST PROCEDURE

MEASUREMENT PROCEDURE REF

1. Set the RBW = 100 kHz.
2. Set the VBW \geq 300 kHz.
3. Detector = peak.
4. Sweep time = auto couple.
5. Trace mode = max hold.
6. Allow trace to fully stabilize.
7. Use the peak marker function to determine the maximum power level in any 100 kHz band segment within the fundamental EBW.

MEASUREMENT PROCEDURE OOB

1. Set RBW = 100 kHz.
2. Set VBW \geq 300 kHz.
3. Set span to encompass the spectrum to be examined.
4. Detector = peak.
5. Trace Mode = max hold.
6. Sweep = auto couple.

4.6.5 DEVIATION FROM TEST STANDARD

No deviation.

4.6.6 EUT OPERATING CONDITION

Same as Item 4.3.6

4.6.7 TEST RESULTS

The conducted emission test is performed on each TX port of operating mode without summing or adding $10\log(N)$ since the limit is relative emission limit. Only worst data of each operating mode is presented.

The spectrum plots are attached on the following pages. D1 line indicates the highest level, and D2 line indicates the 20dB offset below D1. It shows compliance with the requirement.

4.6.8 TEST RESULTS

802.11b

CH 1

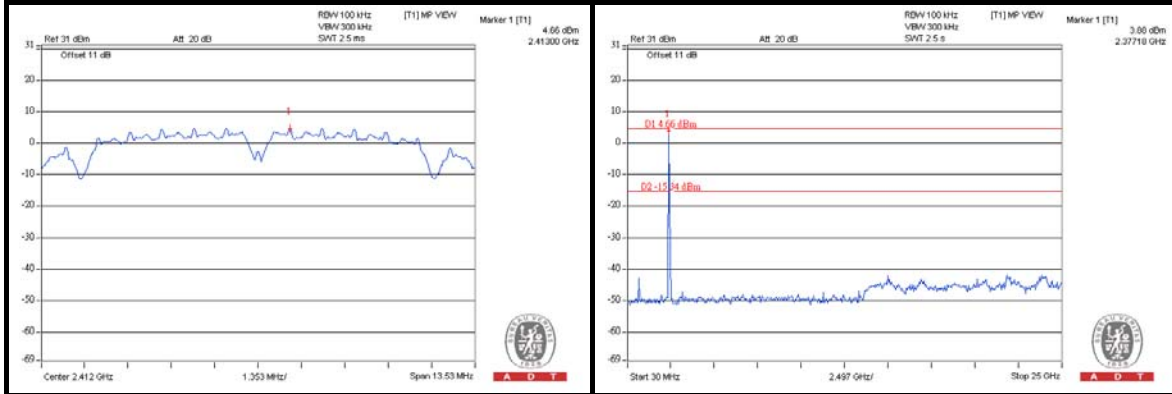

CH 6

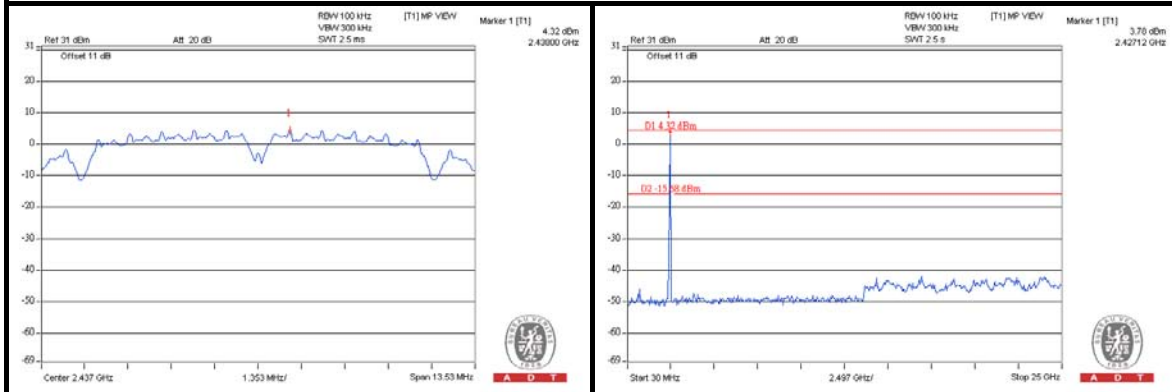

CH 11

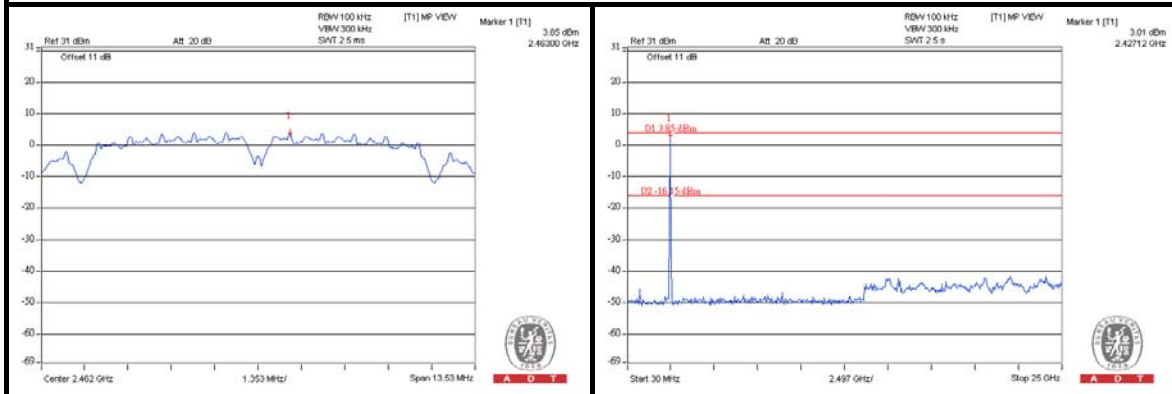

802.11g

CH 1

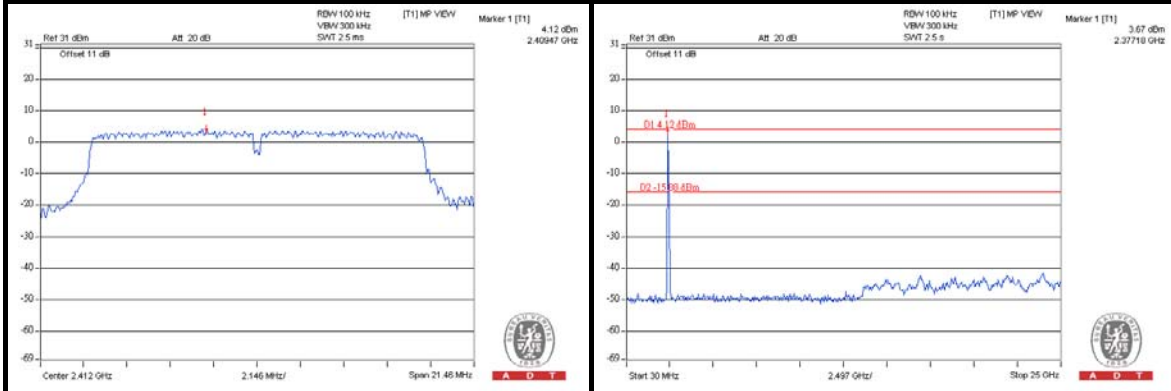

CH 6

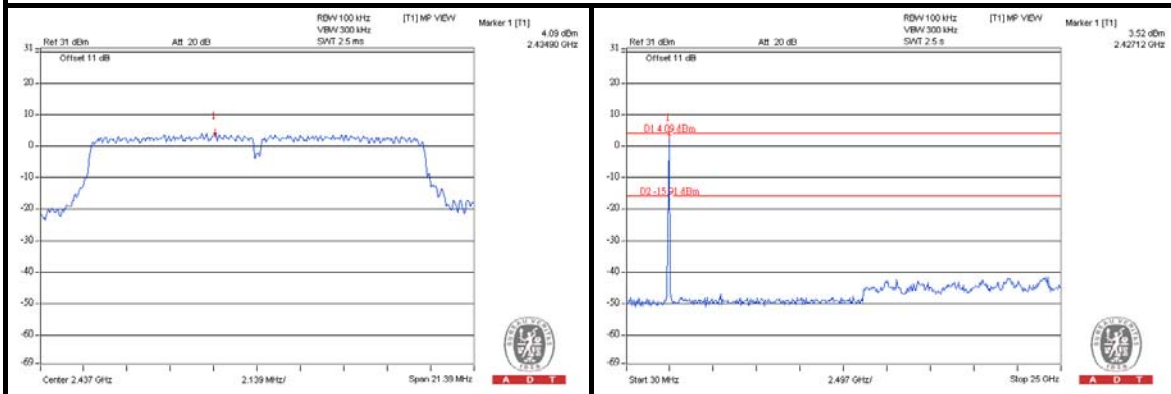

CH 11

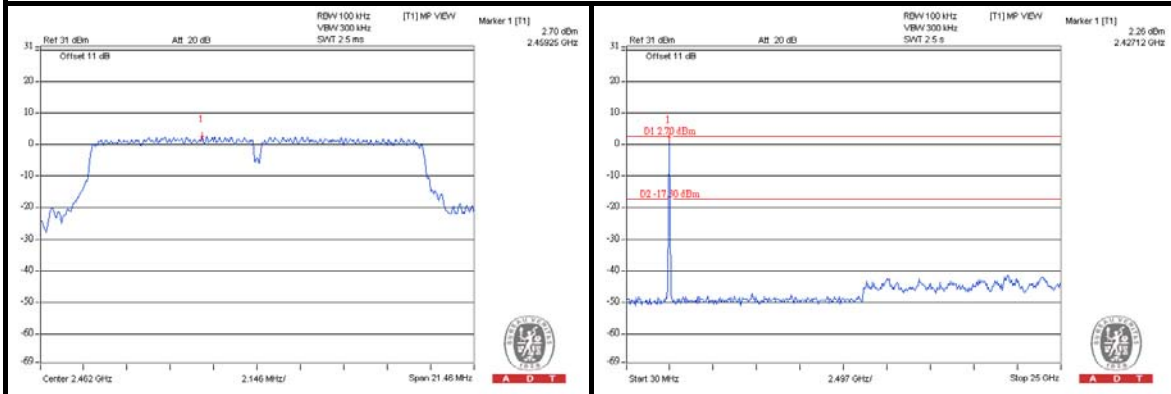

802.11n (20MHz)

CH 1

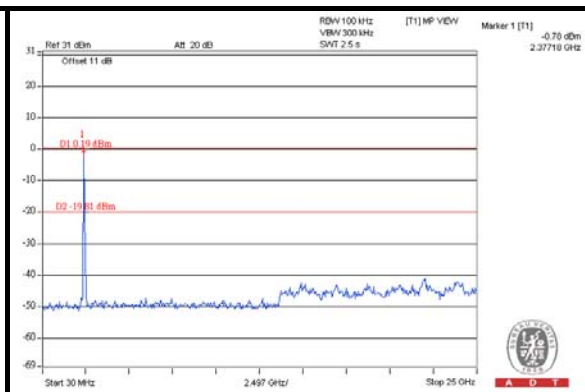
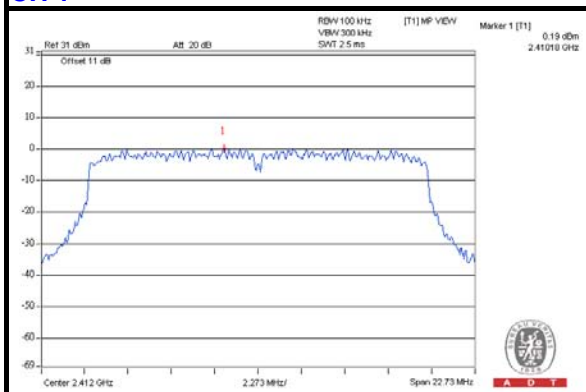

CH 6

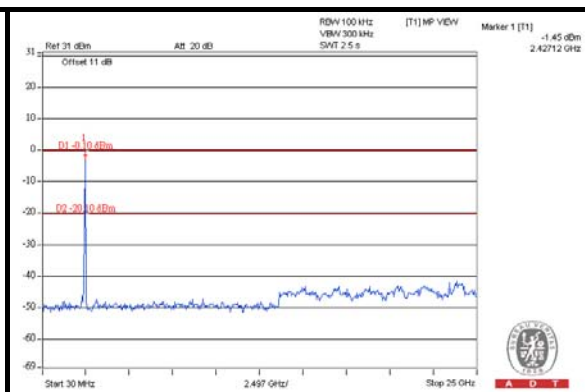
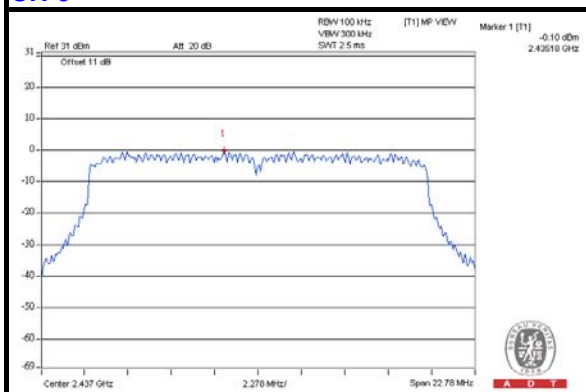

CH 11

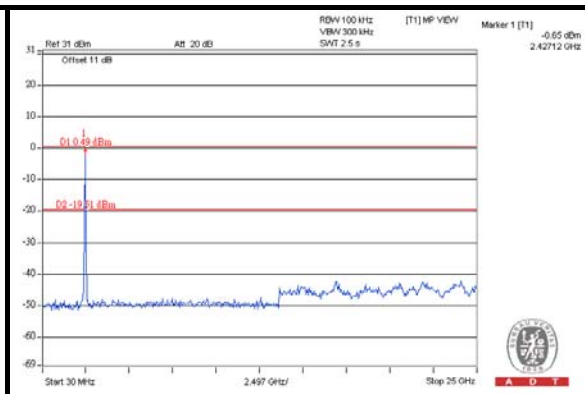
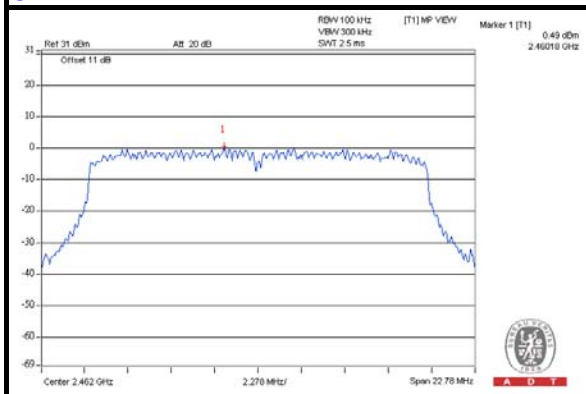

802.11n (40MHz)

CH 3

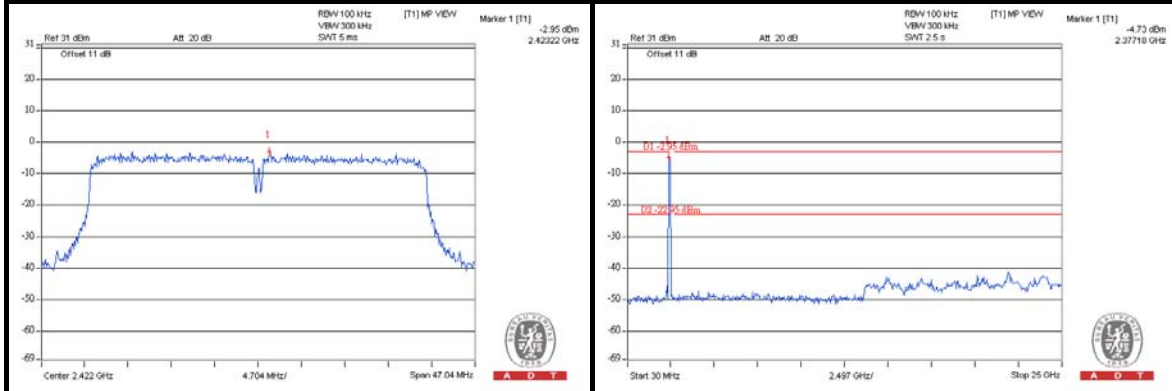

CH 6

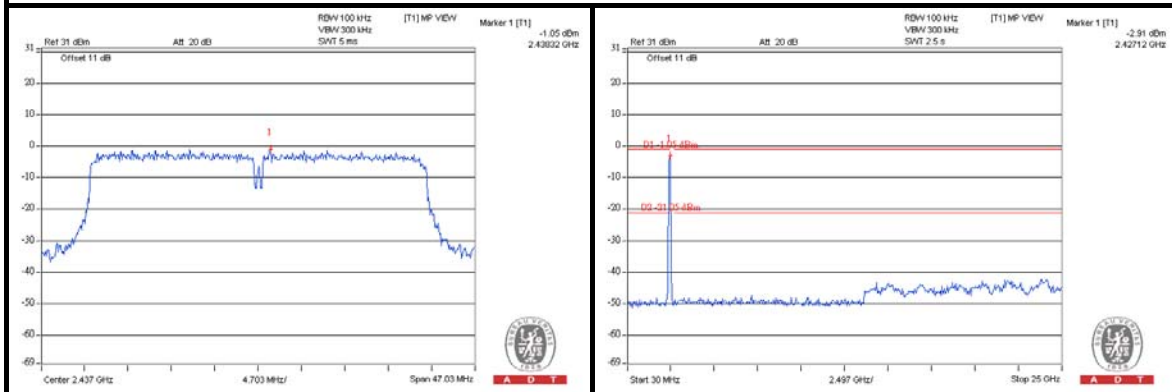

CH 9

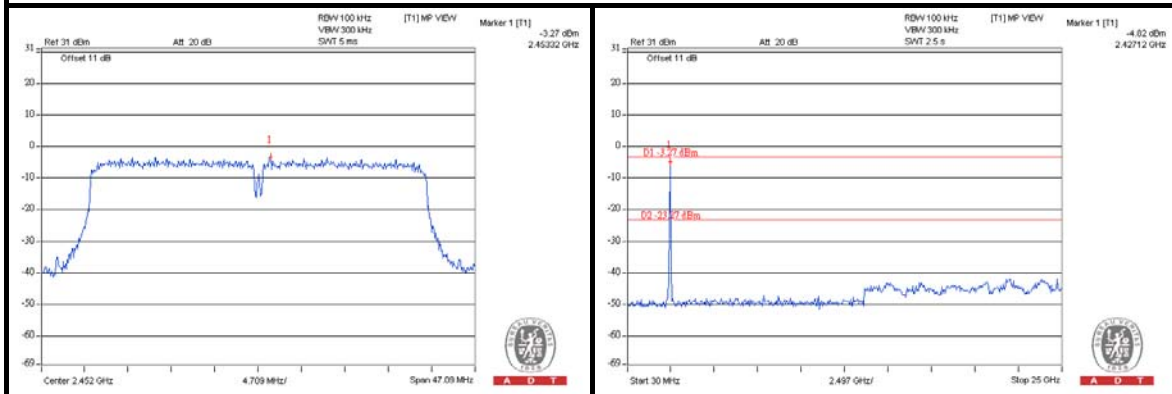

5. TEST TYPES AND RESULTS (FOR 5.0GHz BAND)

5.1 RADIATED EMISSION MEASUREMENT

5.1.1 LIMITS OF RADIATED EMISSION MEASUREMENT

Radiated emissions which fall in the restricted bands must comply with the radiated emission limits specified as below table. Other emissions shall be at least 20dB below the highest level of the desired power:

FREQUENCIES (MHz)	FIELD STRENGTH (microvolts/meter)	MEASUREMENT DISTANCE (meters)
0.009 ~ 0.490	2400/F(kHz)	300
0.490 ~ 1.705	24000/F(kHz)	30
1.705 ~ 30.0	30	30
30 ~ 88	100	3
88 ~ 216	150	3
216 ~ 960	200	3
Above 960	500	3

NOTE:

1. The lower limit shall apply at the transition frequencies.
2. Emission level (dBuV/m) = 20 log Emission level (uV/m).
3. For frequencies above 1000MHz, the field strength limits are based on average detector, however, the peak field strength of any emission shall not exceed the maximum permitted average limits, specified above by more than 20dB under any condition of modulation.

5.1.2 TEST INSTRUMENTS

Same as item 4.1.2.

5.1.3 TEST PROCEDURES

Same as item 4.1.3.

5.1.4 DEVIATION FROM TEST STANDARD

No deviation.

5.1.5 TEST SETUP

Same as item 4.1.5.

5.1.6 EUT OPERATING CONDITIONS

Same as 4.1.6.

5.1.7 TEST RESULTS

ABOVE 1GHz DATA: 802.11a

EUT TEST CONDITION		MEASUREMENT DETAIL	
CHANNEL	Channel 149	FREQUENCY RANGE	1 ~ 40GHz
INPUT POWER (SYSTEM)	120Vac, 60 Hz	DETECTOR FUNCTION	Peak (PK) Average (AV)
ENVIRONMENTAL CONDITIONS	25deg. C, 65%RH	TESTED BY	Aska Huang

ANTENNA POLARITY & TEST DISTANCE: HORIZONTAL AT 3 M								
NO.	FREQ. (MHz)	EMISSION LEVEL (dBuV/m)	LIMIT (dBuV/m)	MARGIN (dB)	ANTENNA HEIGHT (m)	TABLE ANGLE (Degree)	RAW VALUE (dBuV)	CORRECTION FACTOR (dB/m)
1	#5725.00	76.1 PK	91.7	-15.6	1.04 H	169	37.30	38.80
2	#5725.00	62.1 AV	82.1	-20.0	1.04 H	169	23.30	38.80
3	*5745.00	111.7 PK			1.03 H	171	72.90	38.80
4	*5745.00	102.1 AV			1.03 H	171	63.30	38.80
5	11490.00	65.6 PK	74.0	-8.4	1.21 H	18	15.50	50.10
6	11490.00	51.8 AV	54.0	-2.2	1.21 H	18	1.70	50.10
ANTENNA POLARITY & TEST DISTANCE: VERTICAL AT 3 M								
NO.	FREQ. (MHz)	EMISSION LEVEL (dBuV/m)	LIMIT (dBuV/m)	MARGIN (dB)	ANTENNA HEIGHT (m)	TABLE ANGLE (Degree)	RAW VALUE (dBuV)	CORRECTION FACTOR (dB/m)
1	#5725.00	75.3 PK	89.1	-13.8	1.00 V	209	36.50	38.80
2	#5725.00	61.0 AV	79.3	-18.3	1.00 V	209	22.20	38.80
3	*5745.00	109.1 PK			1.30 V	151	70.30	38.80
4	*5745.00	99.3 AV			1.30 V	151	60.50	38.80
5	11490.00	60.3 PK	74.0	-13.7	1.00 V	139	10.20	50.10
6	11490.00	48.0 AV	54.0	-6.0	1.00 V	139	-2.10	50.10

REMARKS:

1. Emission level (dBuV/m) = Raw Value (dBuV) + Correction Factor (dB/m).
2. Correction Factor (dB/m) = Antenna Factor (dB/m) + Cable Factor (dB).
3. The other emission levels were very low against the limit.
4. Margin value = Emission level – Limit value.
5. “ * ”: Fundamental frequency.
6. The limit value is defined as per 15.247.
7. "#":The radiated frequency is out the restricted band.

EUT TEST CONDITION		MEASUREMENT DETAIL	
CHANNEL	Channel 157	FREQUENCY RANGE	1 ~ 40GHz
INPUT POWER (SYSTEM)	120Vac, 60 Hz	DETECTOR FUNCTION	Peak (PK) Average (AV)
ENVIRONMENTAL CONDITIONS	25deg. C, 65%RH	TESTED BY	Aska Huang

ANTENNA POLARITY & TEST DISTANCE: HORIZONTAL AT 3 M								
NO.	FREQ. (MHz)	EMISSION LEVEL (dBuV/m)	LIMIT (dBuV/m)	MARGIN (dB)	ANTENNA HEIGHT (m)	TABLE ANGLE (Degree)	RAW VALUE (dBuV)	CORRECTION FACTOR (dB/m)
1	*5785.00	110.4 PK			1.02 H	168	71.50	38.90
2	*5785.00	100.7 AV			1.02 H	168	61.80	38.90
3	11570.00	61.1 PK	74.0	-12.9	1.21 H	21	11.10	50.00
4	11570.00	48.6 AV	54.0	-5.4	1.21 H	21	-1.40	50.00
5	#17355.00	64.0 PK	90.4	-26.4	1.00 H	28	10.90	53.10
6	#17355.00	51.1 AV	80.7	-29.6	1.00 H	28	-2.00	53.10
ANTENNA POLARITY & TEST DISTANCE: VERTICAL AT 3 M								
NO.	FREQ. (MHz)	EMISSION LEVEL (dBuV/m)	LIMIT (dBuV/m)	MARGIN (dB)	ANTENNA HEIGHT (m)	TABLE ANGLE (Degree)	RAW VALUE (dBuV)	CORRECTION FACTOR (dB/m)
1	*5785.00	108.2 PK			1.17 V	150	69.30	38.90
2	*5785.00	98.2 AV			1.17 V	150	59.30	38.90
3	11570.00	58.0 PK	74.0	-16.0	1.00 V	140	8.00	50.00
4	11570.00	45.3 AV	54.0	-8.7	1.00 V	140	-4.70	50.00
5	#17355.00	63.5 PK	88.2	-24.7	1.00 V	53	10.40	53.10
6	#17355.00	50.9 AV	78.2	-27.3	1.00 V	53	-2.20	53.10

REMARKS:

1. Emission level (dBuV/m) = Raw Value (dBuV) + Correction Factor (dB/m).
2. Correction Factor (dB/m) = Antenna Factor (dB/m) + Cable Factor (dB).
3. The other emission levels were very low against the limit.
4. Margin value = Emission level – Limit value.
5. “ * “: Fundamental frequency.
6. The limit value is defined as per 15.247.
7. “#”:The radiated frequency is out the restricted band.

EUT TEST CONDITION		MEASUREMENT DETAIL	
CHANNEL	Channel 165	FREQUENCY RANGE	1 ~ 40GHz
INPUT POWER (SYSTEM)	120Vac, 60 Hz	DETECTOR FUNCTION	Peak (PK) Average (AV)
ENVIRONMENTAL CONDITIONS	25deg. C, 65%RH	TESTED BY	Aska Huang

ANTENNA POLARITY & TEST DISTANCE: HORIZONTAL AT 3 M								
NO.	FREQ. (MHz)	EMISSION LEVEL (dBuV/m)	LIMIT (dBuV/m)	MARGIN (dB)	ANTENNA HEIGHT (m)	TABLE ANGLE (Degree)	RAW VALUE (dBuV)	CORRECTION FACTOR (dB/m)
1	*5825.00	110.8 PK			1.02 H	168	71.90	38.90
2	*5825.00	101.0 AV			1.02 H	168	62.10	38.90
3	#5850.00	59.4 PK	90.8	-31.4	1.12 H	169	20.40	39.00
4	#5850.00	46.5 AV	81.0	-34.5	1.12 H	169	7.50	39.00
5	11650.00	62.2 PK	74.0	-11.8	1.20 H	19	12.20	50.00
6	11650.00	49.8 AV	54.0	-4.2	1.20 H	19	-0.20	50.00
ANTENNA POLARITY & TEST DISTANCE: VERTICAL AT 3 M								
NO.	FREQ. (MHz)	EMISSION LEVEL (dBuV/m)	LIMIT (dBuV/m)	MARGIN (dB)	ANTENNA HEIGHT (m)	TABLE ANGLE (Degree)	RAW VALUE (dBuV)	CORRECTION FACTOR (dB/m)
1	*5825.00	109.6 PK			1.06 V	152	70.70	38.90
2	*5825.00	99.8 AV			1.06 V	152	60.90	38.90
3	#5850.00	58.8 PK	89.6	-30.8	1.15 V	194	19.80	39.00
4	#5850.00	46.3 AV	79.8	-33.5	1.15 V	194	7.30	39.00
5	11650.00	58.7 PK	74.0	-15.3	1.00 V	20	8.70	50.00
6	11650.00	46.1 AV	54.0	-7.9	1.00 V	20	-3.90	50.00

REMARKS:

1. Emission level (dBuV/m) = Raw Value (dBuV) + Correction Factor (dB/m).
2. Correction Factor (dB/m) = Antenna Factor (dB/m) + Cable Factor (dB).
3. The other emission levels were very low against the limit.
4. Margin value = Emission level – Limit value.
5. “ * “: Fundamental frequency.
6. The limit value is defined as per 15.247.
7. “#”:The radiated frequency is out the restricted band.

802.11n (20MHz)

EUT TEST CONDITION		MEASUREMENT DETAIL	
CHANNEL	Channel 149	FREQUENCY RANGE	1 ~ 40GHz
INPUT POWER (SYSTEM)	120Vac, 60 Hz	DETECTOR FUNCTION	Peak (PK) Average (AV)
ENVIRONMENTAL CONDITIONS	25deg. C, 65%RH	TESTED BY	Aska Huang

ANTENNA POLARITY & TEST DISTANCE: HORIZONTAL AT 3 M								
NO.	FREQ. (MHz)	EMISSION LEVEL (dBuV/m)	LIMIT (dBuV/m)	MARGIN (dB)	ANTENNA HEIGHT (m)	TABLE ANGLE (Degree)	RAW VALUE (dBuV)	CORRECTION FACTOR (dB/m)
1	#5725.00	62.5 PK	88.8	-26.3	1.26 H	168	23.70	38.80
2	#5725.00	47.5 AV	77.7	-30.2	1.26 H	168	8.70	38.80
3	*5745.00	108.8 PK			1.24 H	169	70.00	38.80
4	*5745.00	97.7 AV			1.24 H	169	58.90	38.80
5	11490.00	60.9 PK	74.0	-13.1	1.28 H	19	10.80	50.10
6	11490.00	48.4 AV	54.0	-5.6	1.28 H	19	-1.70	50.10

ANTENNA POLARITY & TEST DISTANCE: VERTICAL AT 3 M								
NO.	FREQ. (MHz)	EMISSION LEVEL (dBuV/m)	LIMIT (dBuV/m)	MARGIN (dB)	ANTENNA HEIGHT (m)	TABLE ANGLE (Degree)	RAW VALUE (dBuV)	CORRECTION FACTOR (dB/m)
1	#5725.00	60.9 PK	88.0	-27.1	1.00 V	155	22.10	38.80
2	#5725.00	46.3 AV	76.5	-30.2	1.00 V	155	7.50	38.80
3	*5745.00	108.0 PK			1.00 V	156	69.20	38.80
4	*5745.00	96.5 AV			1.00 V	156	57.70	38.80
5	11490.00	59.6 PK	74.0	-14.4	1.00 V	331	9.50	50.10
6	11490.00	47.5 AV	54.0	-6.5	1.00 V	331	-2.60	50.10

REMARKS:

1. Emission level (dBuV/m) = Raw Value (dBuV) + Correction Factor (dB/m).
2. Correction Factor (dB/m) = Antenna Factor (dB/m) + Cable Factor (dB).
3. The other emission levels were very low against the limit.
4. Margin value = Emission level – Limit value.
5. “ * “: Fundamental frequency.
6. The limit value is defined as per 15.247.
7. "#":The radiated frequency is out the restricted band.

EUT TEST CONDITION		MEASUREMENT DETAIL	
CHANNEL	Channel 157	FREQUENCY RANGE	1 ~ 40GHz
INPUT POWER (SYSTEM)	120Vac, 60 Hz	DETECTOR FUNCTION	Peak (PK) Average (AV)
ENVIRONMENTAL CONDITIONS	25deg. C, 65%RH	TESTED BY	Aska Huang

ANTENNA POLARITY & TEST DISTANCE: HORIZONTAL AT 3 M								
NO.	FREQ. (MHz)	EMISSION LEVEL (dBuV/m)	LIMIT (dBuV/m)	MARGIN (dB)	ANTENNA HEIGHT (m)	TABLE ANGLE (Degree)	RAW VALUE (dBuV)	CORRECTION FACTOR (dB/m)
1	*5785.00	108.5 PK			1.23 H	167	69.60	38.90
2	*5785.00	97.3 AV			1.23 H	167	58.40	38.90
3	11570.00	60.5 PK	74.0	-13.5	1.35 H	14	10.50	50.00
4	11570.00	48.4 AV	54.0	-5.6	1.35 H	14	-1.60	50.00
5	#17355.00	64.4 PK	88.5	-24.1	1.00 H	58	11.30	53.10
6	#17355.00	51.1 AV	77.3	-26.2	1.00 H	58	-2.00	53.10
ANTENNA POLARITY & TEST DISTANCE: VERTICAL AT 3 M								
NO.	FREQ. (MHz)	EMISSION LEVEL (dBuV/m)	LIMIT (dBuV/m)	MARGIN (dB)	ANTENNA HEIGHT (m)	TABLE ANGLE (Degree)	RAW VALUE (dBuV)	CORRECTION FACTOR (dB/m)
1	*5785.00	107.5 PK			1.16 V	151	68.60	38.90
2	*5785.00	96.0 AV			1.16 V	151	57.10	38.90
3	11570.00	58.8 PK	74.0	-15.2	1.00 V	20	8.80	50.00
4	11570.00	45.5 AV	54.0	-8.5	1.00 V	20	-4.50	50.00
5	#17355.00	63.9 PK	87.5	-23.6	1.00 V	53	10.80	53.10
6	#17355.00	50.9 AV	76.0	-25.1	1.00 V	53	-2.20	53.10

REMARKS:

1. Emission level (dBuV/m) = Raw Value (dBuV) + Correction Factor (dB/m).
2. Correction Factor (dB/m) = Antenna Factor (dB/m) + Cable Factor (dB).
3. The other emission levels were very low against the limit.
4. Margin value = Emission level – Limit value.
5. “ * “: Fundamental frequency.
6. The limit value is defined as per 15.247.
7. “#”:The radiated frequency is out the restricted band.

EUT TEST CONDITION		MEASUREMENT DETAIL	
CHANNEL	Channel 165	FREQUENCY RANGE	1 ~ 40GHz
INPUT POWER (SYSTEM)	120Vac, 60 Hz	DETECTOR FUNCTION	Peak (PK) Average (AV)
ENVIRONMENTAL CONDITIONS	25deg. C, 65%RH	TESTED BY	Aska Huang

ANTENNA POLARITY & TEST DISTANCE: HORIZONTAL AT 3 M								
NO.	FREQ. (MHz)	EMISSION LEVEL (dBuV/m)	LIMIT (dBuV/m)	MARGIN (dB)	ANTENNA HEIGHT (m)	TABLE ANGLE (Degree)	RAW VALUE (dBuV)	CORRECTION FACTOR (dB/m)
1	*5825.00	107.9 PK			1.23 H	168	69.00	38.90
2	*5825.00	96.9 AV			1.23 H	168	58.00	38.90
3	#5850.00	51.3 PK	87.9	-36.6	1.00 H	169	12.30	39.00
4	#5850.00	40.5 AV	76.9	-36.4	1.00 H	169	1.50	39.00
5	11650.00	60.6 PK	74.0	-13.4	1.33 H	15	10.60	50.00
6	11650.00	48.1 AV	54.0	-5.9	1.33 H	15	-1.90	50.00
ANTENNA POLARITY & TEST DISTANCE: VERTICAL AT 3 M								
NO.	FREQ. (MHz)	EMISSION LEVEL (dBuV/m)	LIMIT (dBuV/m)	MARGIN (dB)	ANTENNA HEIGHT (m)	TABLE ANGLE (Degree)	RAW VALUE (dBuV)	CORRECTION FACTOR (dB/m)
1	*5825.00	107.4 PK			1.00 V	79	68.50	38.90
2	*5825.00	94.9 AV			1.00 V	79	56.00	38.90
3	#5850.00	53.0 PK	87.4	-34.4	1.00 V	79	14.00	39.00
4	#5850.00	43.2 AV	74.9	-31.7	1.00 V	79	4.20	39.00
5	11650.00	57.9 PK	74.0	-16.1	1.00 V	36	7.90	50.00
6	11650.00	45.4 AV	54.0	-8.6	1.00 V	36	-4.60	50.00

REMARKS:

1. Emission level (dBuV/m) = Raw Value (dBuV) + Correction Factor (dB/m).
2. Correction Factor (dB/m) = Antenna Factor (dB/m) + Cable Factor (dB).
3. The other emission levels were very low against the limit.
4. Margin value = Emission level – Limit value.
5. “ * “: Fundamental frequency.
6. The limit value is defined as per 15.247.
7. “#”:The radiated frequency is out the restricted band.

802.11n (40MHz)

EUT TEST CONDITION		MEASUREMENT DETAIL	
CHANNEL	Channel 151	FREQUENCY RANGE	1 ~ 40GHz
INPUT POWER (SYSTEM)	120Vac, 60 Hz	DETECTOR FUNCTION	Peak (PK) Average (AV)
ENVIRONMENTAL CONDITIONS	25deg. C, 65%RH	TESTED BY	Aska Huang

ANTENNA POLARITY & TEST DISTANCE: HORIZONTAL AT 3 M								
NO.	FREQ. (MHz)	EMISSION LEVEL (dBuV/m)	LIMIT (dBuV/m)	MARGIN (dB)	ANTENNA HEIGHT (m)	TABLE ANGLE (Degree)	RAW VALUE (dBuV)	CORRECTION FACTOR (dB/m)
1	#5725.00	75.3 PK	86.1	-10.8	1.04 H	169	36.50	38.80
2	#5725.00	61.2 AV	74.2	-13.0	1.04 H	169	22.40	38.80
3	*5755.00	106.1 PK			1.03 H	167	67.30	38.80
4	*5755.00	94.2 AV			1.03 H	167	55.40	38.80
5	11510.00	59.2 PK	74.0	-14.8	1.00 H	20	9.10	50.10
6	11510.00	46.8 AV	54.0	-7.2	1.00 H	20	-3.30	50.10
ANTENNA POLARITY & TEST DISTANCE: VERTICAL AT 3 M								
NO.	FREQ. (MHz)	EMISSION LEVEL (dBuV/m)	LIMIT (dBuV/m)	MARGIN (dB)	ANTENNA HEIGHT (m)	TABLE ANGLE (Degree)	RAW VALUE (dBuV)	CORRECTION FACTOR (dB/m)
1	#5725.00	71.9 PK	85.2	-13.3	1.00 V	81	33.10	38.80
2	#5725.00	59.6 AV	73.8	-14.2	1.00 V	81	20.80	38.80
3	*5755.00	105.2 PK			1.00 V	79	66.40	38.80
4	*5755.00	93.8 AV			1.00 V	79	55.00	38.80
5	11510.00	58.7 PK	74.0	-15.3	1.00 V	69	8.60	50.10
6	11510.00	45.6 AV	54.0	-8.4	1.00 V	69	-4.50	50.10

REMARKS:

1. Emission level (dBuV/m) = Raw Value (dBuV) + Correction Factor (dB/m).
2. Correction Factor (dB/m) = Antenna Factor (dB/m) + Cable Factor (dB).
3. The other emission levels were very low against the limit.
4. Margin value = Emission level – Limit value.
5. “ * “: Fundamental frequency.
6. The limit value is defined as per 15.247.
7. "#":The radiated frequency is out the restricted band.

EUT TEST CONDITION		MEASUREMENT DETAIL	
CHANNEL	Channel 159	FREQUENCY RANGE	1 ~ 40GHz
INPUT POWER (SYSTEM)	120Vac, 60 Hz	DETECTOR FUNCTION	Peak (PK) Average (AV)
ENVIRONMENTAL CONDITIONS	25deg. C, 65%RH	TESTED BY	Aska Huang

ANTENNA POLARITY & TEST DISTANCE: HORIZONTAL AT 3 M								
NO.	FREQ. (MHz)	EMISSION LEVEL (dBuV/m)	LIMIT (dBuV/m)	MARGIN (dB)	ANTENNA HEIGHT (m)	TABLE ANGLE (Degree)	RAW VALUE (dBuV)	CORRECTION FACTOR (dB/m)
1	*5795.00	104.5 PK			1.02 H	167	65.60	38.90
2	*5795.00	93.3 AV			1.02 H	167	54.40	38.90
3	#5850.00	55.0 PK	84.5	-29.5	1.21 H	191	16.00	39.00
4	#5850.00	43.2 AV	73.3	-30.1	1.21 H	191	4.20	39.00
5	11590.00	58.6 PK	74.0	-15.4	1.00 H	21	8.60	50.00
6	11590.00	47.0 AV	54.0	-7.0	1.00 H	21	-3.00	50.00
ANTENNA POLARITY & TEST DISTANCE: VERTICAL AT 3 M								
NO.	FREQ. (MHz)	EMISSION LEVEL (dBuV/m)	LIMIT (dBuV/m)	MARGIN (dB)	ANTENNA HEIGHT (m)	TABLE ANGLE (Degree)	RAW VALUE (dBuV)	CORRECTION FACTOR (dB/m)
1	*5795.00	105.5 PK			1.00 V	88	66.60	38.90
2	*5795.00	93.9 AV			1.00 V	88	55.00	38.90
3	#5850.00	54.8 PK	85.5	-30.7	1.00 V	79	15.80	39.00
4	#5850.00	44.0 AV	73.9	-29.9	1.00 V	79	5.00	39.00
5	11590.00	58.5 PK	74.0	-15.5	1.00 V	69	8.50	50.00
6	11590.00	45.7 AV	54.0	-8.3	1.00 V	69	-4.30	50.00

REMARKS:

1. Emission level (dBuV/m) = Raw Value (dBuV) + Correction Factor (dB/m).
2. Correction Factor (dB/m) = Antenna Factor (dB/m) + Cable Factor (dB).
3. The other emission levels were very low against the limit.
4. Margin value = Emission level – Limit value.
5. “ * “: Fundamental frequency.
6. The limit value is defined as per 15.247.
7. “#”:The radiated frequency is out the restricted band.

BELOW 1GHz WORST-CASE DATA : 802.11n (20MHz)

EUT TEST CONDITION		MEASUREMENT DETAIL	
CHANNEL	Channel 149	FREQUENCY RANGE	Below 1000MHz
INPUT POWER (SYSTEM)	120Vac, 60 Hz	DETECTOR FUNCTION	Quasi-Peak
ENVIRONMENTAL CONDITIONS	25deg. C, 65%RH	TESTED BY	Aska Huang

ANTENNA POLARITY & TEST DISTANCE: HORIZONTAL AT 3 M								
NO.	FREQ. (MHz)	EMISSION LEVEL (dBuV/m)	LIMIT (dBuV/m)	MARGIN (dB)	ANTENNA HEIGHT (m)	TABLE ANGLE (Degree)	RAW VALUE (dBuV)	CORRECTION FACTOR (dB/m)
1	86.67	37.1 QP	40.0	-2.9	1.98 H	15	28.30	8.80
2	167.94	36.6 QP	43.5	-6.9	1.50 H	31	23.00	13.60
3	249.60	34.6 QP	46.0	-11.4	1.00 H	184	21.60	13.00
4	374.04	40.7 QP	46.0	-5.3	1.00 H	52	23.80	16.90
5	504.31	42.0 QP	46.0	-4.0	1.24 H	100	22.00	20.00
6	624.85	39.4 QP	46.0	-6.6	1.24 H	18	17.10	22.30
ANTENNA POLARITY & TEST DISTANCE: VERTICAL AT 3 M								
NO.	FREQ. (MHz)	EMISSION LEVEL (dBuV/m)	LIMIT (dBuV/m)	MARGIN (dB)	ANTENNA HEIGHT (m)	TABLE ANGLE (Degree)	RAW VALUE (dBuV)	CORRECTION FACTOR (dB/m)
1	39.11	34.6 QP	40.0	-5.4	1.00 V	164	21.10	13.50
2	160.17	35.3 QP	43.5	-8.2	1.00 V	291	21.20	14.10
3	249.60	31.1 QP	46.0	-14.9	1.00 V	155	18.10	13.00
4	374.04	41.5 QP	46.0	-4.5	1.00 V	176	24.60	16.90
5	500.42	42.2 QP	46.0	-3.8	1.74 V	20	22.20	20.00
6	624.85	34.7 QP	46.0	-11.3	1.24 V	211	12.40	22.30

REMARKS:

1. Emission level (dBuV/m) = Raw Value (dBuV) + Correction Factor (dB/m).
2. Correction Factor (dB/m) = Antenna Factor (dB/m) + Cable Factor (dB).
3. The other emission levels were very low against the limit.
4. Margin value = Emission level – Limit value.

5.2 CONDUCTED EMISSION MEASUREMENT

5.2.1 LIMITS OF CONDUCTED EMISSION MEASUREMENT

FREQUENCY OF EMISSION (MHz)	CONDUCTED LIMIT (dB μ V)	
	Quasi-peak	Average
0.15 ~ 0.5	66 to 56	56 to 46
0.5 ~ 5	56	46
5 ~ 30	60	50

- NOTE:**
1. The lower limit shall apply at the transition frequencies.
 2. The limit decreases in line with the logarithm of the frequency in the range of 0.15 to 0.50MHz.
 3. All emanations from a class A/B digital device or system, including any network of conductors and apparatus connected thereto, shall not exceed the level of field strengths specified above.

5.2.2 TEST INSTRUMENTS

Same as item 4.2.2.

5.2.3 TEST PROCEDURES

Same as item 4.2.3.

5.2.4 DEVIATION FROM TEST STANDARD

No deviation.

5.2.5 TEST SETUP

Same as item 4.2.5.

5.2.6 EUT OPERATING CONDITIONS

Same as 4.1.6

5.2.7 TEST RESULTS

CONDUCTED WORST-CASE DATA : 802.11n (20MHz)

PHASE	Line 1	6dB BANDWIDTH	9kHz
-------	--------	---------------	------

No	Freq. [MHz]	Corr.	Reading Value		Emission Level		Limit		Margin	
		Factor	[dB (uV)]		[dB (uV)]		[dB (uV)]		(dB)	
		(dB)	Q.P.	AV.	Q.P.	AV.	Q.P.	AV.	Q.P.	AV.
1	0.19297	0.17	36.35	21.72	36.52	21.89	63.91	53.91	-27.39	-32.02
2	0.51328	0.21	34.43	23.17	34.64	23.38	56.00	46.00	-21.36	-22.62
3	3.23047	0.36	33.39	23.92	33.75	24.28	56.00	46.00	-22.25	-21.72
4	4.96094	0.40	35.91	27.55	36.31	27.95	56.00	46.00	-19.69	-18.05
5	7.86719	0.45	38.87	29.46	39.32	29.91	60.00	50.00	-20.68	-20.09
6	20.85547	0.72	37.22	30.33	37.94	31.05	60.00	50.00	-22.06	-18.95

- REMARKS:**
1. Q.P. and AV. are abbreviations of quasi-peak and average individually.
 2. The emission levels of other frequencies were very low against the limit.
 3. Margin value = Emission level - Limit value
 4. Correction factor = Insertion loss + Cable loss
 5. Emission Level = Correction Factor + Reading Value.

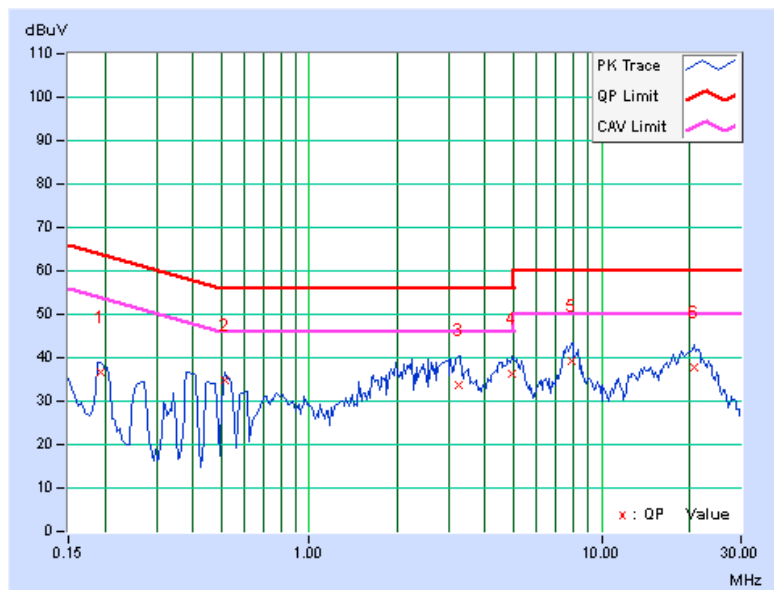

PHASE	Line 2	6dB BANDWIDTH	9kHz
-------	--------	---------------	------

No	Freq. [MHz]	Corr.	Reading Value		Emission Level		Limit		Margin	
		Factor	[dB (uV)]		[dB (uV)]		[dB (uV)]		(dB)	
		(dB)	Q.P.	AV.	Q.P.	AV.	Q.P.	AV.	Q.P.	AV.
1	0.19297	0.15	37.09	27.81	37.24	27.96	63.91	53.91	-26.66	-25.94
2	0.38828	0.18	36.49	27.83	36.67	28.01	58.10	48.10	-21.43	-20.09
3	2.40625	0.29	34.95	21.61	35.24	21.90	56.00	46.00	-20.76	-24.10
4	4.60547	0.40	37.33	28.90	37.73	29.30	56.00	46.00	-18.27	-16.70
5	7.80078	0.50	38.46	28.92	38.96	29.42	60.00	50.00	-21.04	-20.58
6	20.21484	0.82	35.84	28.68	36.66	29.50	60.00	50.00	-23.34	-20.50

- REMARKS:**
1. Q.P. and AV. are abbreviations of quasi-peak and average individually.
 2. The emission levels of other frequencies were very low against the limit.
 3. Margin value = Emission level - Limit value
 4. Correction factor = Insertion loss + Cable loss
 5. Emission Level = Correction Factor + Reading Value.

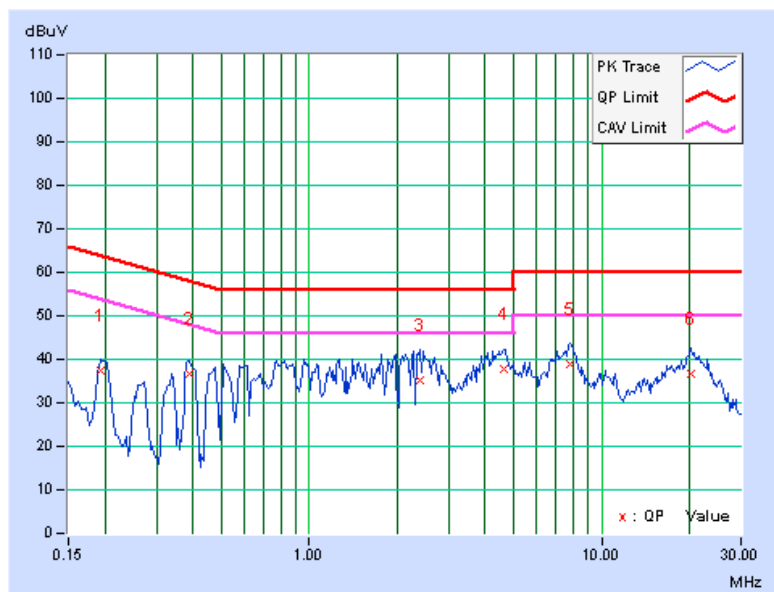

5.3 6dB BANDWIDTH MEASUREMENT

5.3.1 LIMITS OF 6dB BANDWIDTH MEASUREMENT

The minimum of 6dB Bandwidth Measurement is 0.5MHz.

5.3.2 TEST SETUP

Same as item 4.3.2.

5.3.3 TEST INSTRUMENTS

Refer to section 4.1.2 to get information of above instrument.

5.3.4 TEST PROCEDURE

Same as item 4.3.4.

5.3.5 DEVIATION FROM TEST STANDARD

No deviation.

5.3.6 EUT OPERATING CONDITIONS

Same as item 4.3.6.

5.3.7 TEST RESULTS

802.11a

CHANNEL	FREQUENCY (MHz)	6dB BANDWIDTH (MHz)	MINIMUM LIMIT (MHz)	PASS / FAIL
149	5745	16.07	0.5	PASS
157	5785	16.26	0.5	PASS
165	5825	16.28	0.5	PASS

802.11n (20MHz)

CHANNEL	FREQUENCY (MHz)	6dB BANDWIDTH (MHz)			MINIMUM LIMIT (MHz)	PASS / FAIL
		CHAIN 0	CHAIN 1	CHAIN 2		
149	5745	17.20	16.77	16.84	0.5	PASS
157	5785	17.03	16.86	16.81	0.5	PASS
165	5825	17.12	16.85	16.81	0.5	PASS

802.11n (40MHz)

CHANNEL	FREQUENCY (MHz)	6dB BANDWIDTH (MHz)			MINIMUM LIMIT (MHz)	PASS / FAIL
		CHAIN 0	CHAIN 1	CHAIN 2		
151	5755	35.99	35.84	35.87	0.5	PASS
159	5795	36.02	35.94	35.85	0.5	PASS

5.4 CONDUCTED OUTPUT POWER

5.4.1 LIMITS OF CONDUCTED OUTPUT POWER MEASUREMENT

For systems using digital modulation in the 5725 –5850 MHz bands: 1 Watt (30dBm)

5.4.2 TEST SETUP

Same as Item 4.4.2.

5.4.3 INSTRUMENTS

Refer to section 4.1.2 to get information of above instrument.

5.4.4 TEST PROCEDURES

Same as Item 4.4.4.

5.4.5 DEVIATION FROM TEST STANDARD

No deviation.

5.4.6 EUT OPERATING CONDITIONS

Same as Item 4.3.6.

5.4.7 TEST RESULTS

802.11a

CHANNEL	FREQUENCY (MHz)	PEAK POWER (mW)	PEAK POWER (dBm)	LIMIT (dBm)	PASS/FAIL
149	5745	277.3	24.43	30	PASS
157	5785	274.8	24.39	30	PASS
165	5825	266.7	24.26	30	PASS

802.11n (20MHz)

CHAN.	CHAN. FREQ. (MHz)	PEAK POWER (dBm)			TOTAL POWER (mW)	TOTAL POWER (dBm)	LIMIT (dBm)	PASS / FAIL
		CHAIN 0	CHAIN 1	CHAIN 2				
149	5745	23.18	23.19	23.39	634.7	28.0	30	PASS
157	5785	23.14	23.28	23.16	625.9	28.0	30	PASS
165	5825	23.01	22.75	22.86	581.5	27.6	30	PASS

802.11n (40MHz)

CHAN.	CHAN. FREQ. (MHz)	PEAK POWER (dBm)			TOTAL POWER (mW)	TOTAL POWER (dBm)	LIMIT (dBm)	PASS / FAIL
		CHAIN 0	CHAIN 1	CHAIN 2				
151	5755	23.21	23.16	23.33	631.7	28.0	30	PASS
159	5795	23.15	23.02	23.39	625.3	28.0	30	PASS

5.5 POWER SPECTRAL DENSITY MEASUREMENT

5.5.1 LIMITS OF POWER SPECTRAL DENSITY MEASUREMENT

The Maximum of Power Spectral Density Measurement is 8dBm.

5.5.2 TEST SETUP

Same as item 4.5.2.

5.5.3 TEST INSTRUMENTS

Refer to section 4.1.2 to get information of above instrument.

5.5.4 TEST PROCEDURE.

Same as item 4.5.4.

5.5.5 DEVIATION FROM TEST STANDARD

No deviation.

5.5.6 EUT OPERATING CONDITION

Same as item 4.3.6.

5.5.7 TEST RESULTS

802.11a

Channel	FREQ. (MHz)	PSD (dBm/100kHz)	PSD (dBm/3kHz)	Limit (dBm/3kHz)	PASS /FAIL
149	5745	4.83	-10.40	8	PASS
157	5785	4.66	-10.57	8	PASS
165	5825	4.42	-10.81	8	PASS

802.11n (20MHz)

TX chain	Channel	FREQ. (MHz)	PSD (dBm/100kHz)	PSD (dBm/3kHz)	10 log (N=3) dB	Total PSD (dBm/3kHz)	Limit (dBm/3kHz)	PASS /FAIL
0	149	5745	1.87	-13.36	4.77	-8.59	8	PASS
	157	5785	1.70	-13.53	4.77	-8.76	8	PASS
	165	5825	1.51	-13.72	4.77	-8.95	8	PASS
1	149	5745	2.62	-12.61	4.77	-7.84	8	PASS
	157	5785	2.59	-12.64	4.77	-7.87	8	PASS
	165	5825	2.22	-13.01	4.77	-8.24	8	PASS
2	149	5745	2.75	-12.48	4.77	-7.71	8	PASS
	157	5785	2.42	-12.81	4.77	-8.04	8	PASS
	165	5825	2.06	-13.17	4.77	-8.40	8	PASS

802.11n (40MHz)

TX chain	Channel	FREQ. (MHz)	PSD (dBm/100kHz)	PSD (dBm/3kHz)	10 log (N=3) dB	Total PSD (dBm/3kHz)	Limit (dBm/3kHz)	PASS /FAIL
0	151	5755	-1.16	-16.39	4.77	-11.62	8	PASS
	159	5795	-1.17	-16.40	4.77	-11.63	8	PASS
1	151	5755	0.50	-14.73	4.77	-9.96	8	PASS
	159	5795	0.37	-14.86	4.77	-10.09	8	PASS
2	151	5755	-0.58	-15.81	4.77	-11.04	8	PASS
	159	5795	-0.48	-15.71	4.77	-10.94	8	PASS

5.6 CONDUCTED OUT OF BAND EMISSION MEASUREMENT

5.6.1 LIMITS OF CONDUCTED OUT OF BAND EMISSION MEASUREMENT

Below -20dB of the highest emission level of operating band (in 100kHz Resolution Bandwidth).

5.6.2 TEST SETUP

Same as Item 4.6.2

5.6.3 TEST INSTRUMENTS

Refer to section 4.1.2 to get information of above instrument.

5.6.4 TEST PROCEDURE

Same as Item 4.6.4

5.6.5 DEVIATION FROM TEST STANDARD

No deviation.

5.6.6 EUT OPERATING CONDITION

Same as Item 4.3.6

5.6.7 TEST RESULTS

The conducted emission test is performed on each TX port of operating mode without summing or adding $10\log(N)$ since the limit is relative emission limit. Only worst data of each operating mode is presented.

The spectrum plots are attached on the following pages. D1 line indicates the highest level, and D2 line indicates the 20dB offset below D1. It shows compliance with the requirement.

802.11a

CH 149

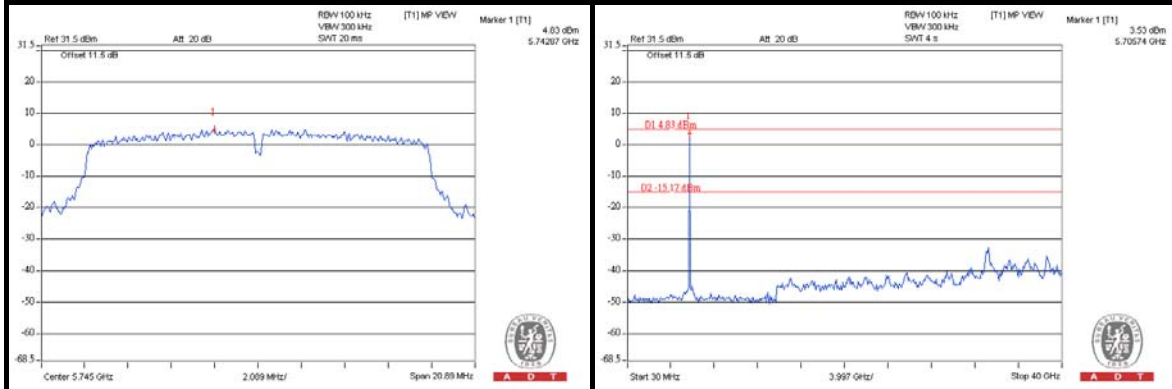

CH 157

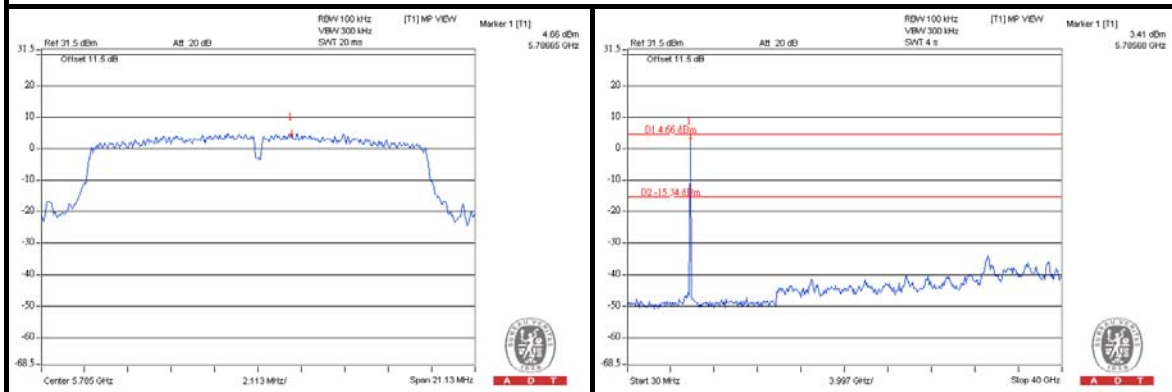

CH 165

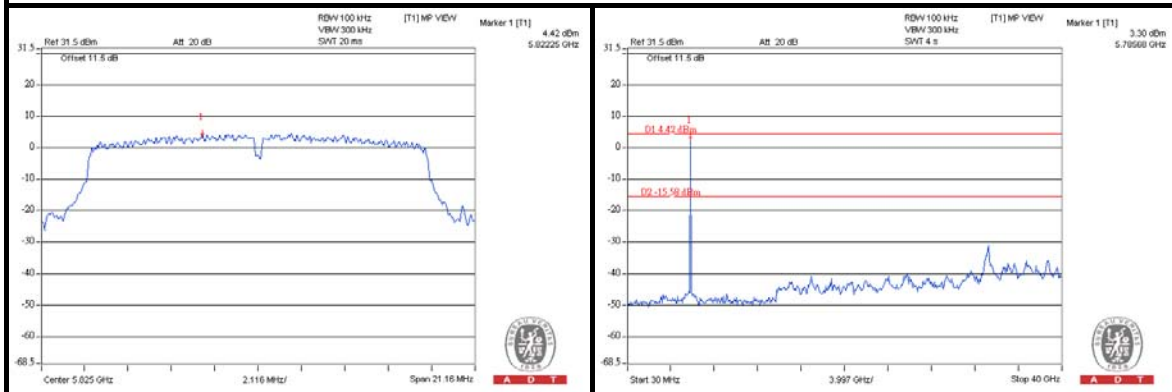

802.11n (20MHz)

CH 149

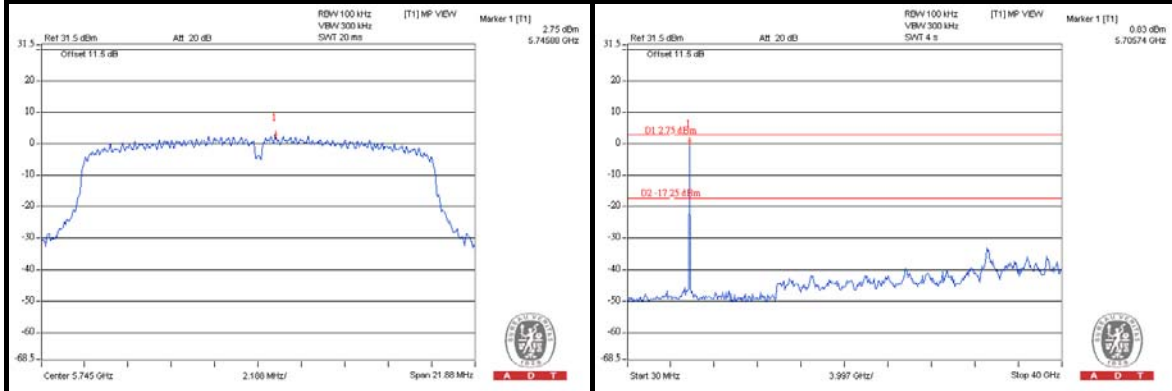

CH 157

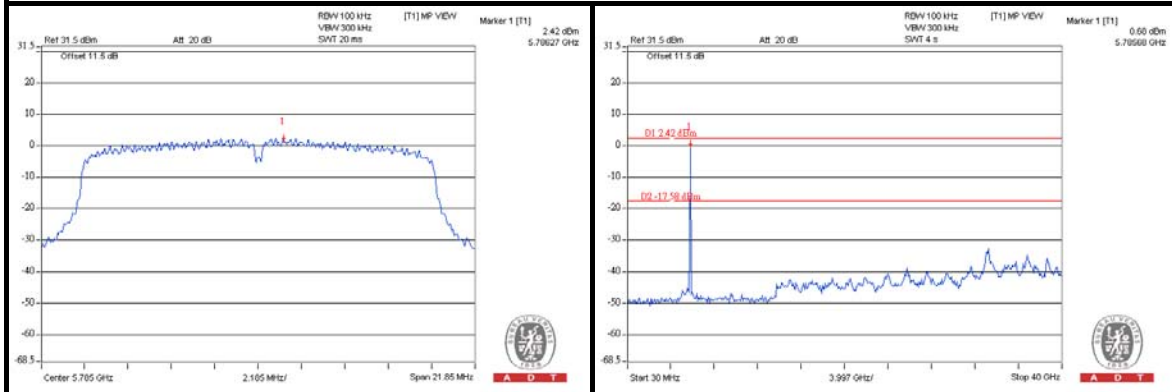

CH 165

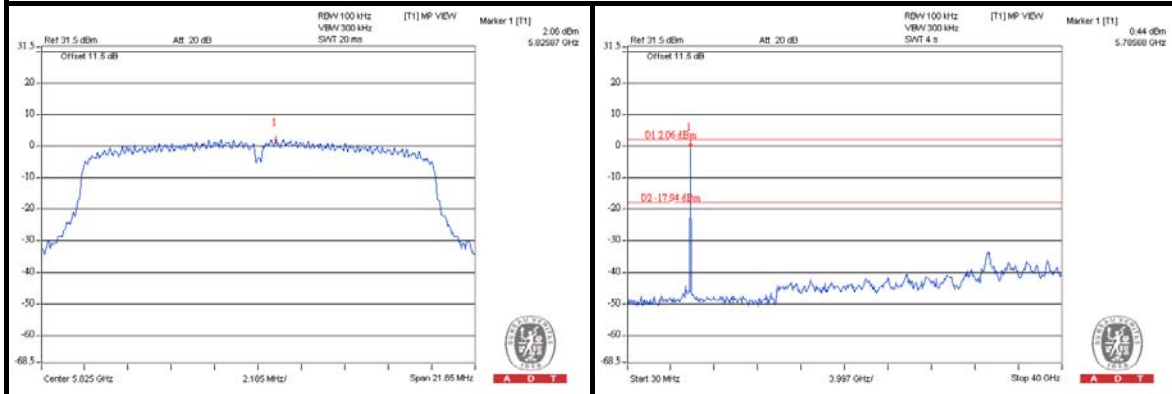

802.11n (40MHz)

CH 151

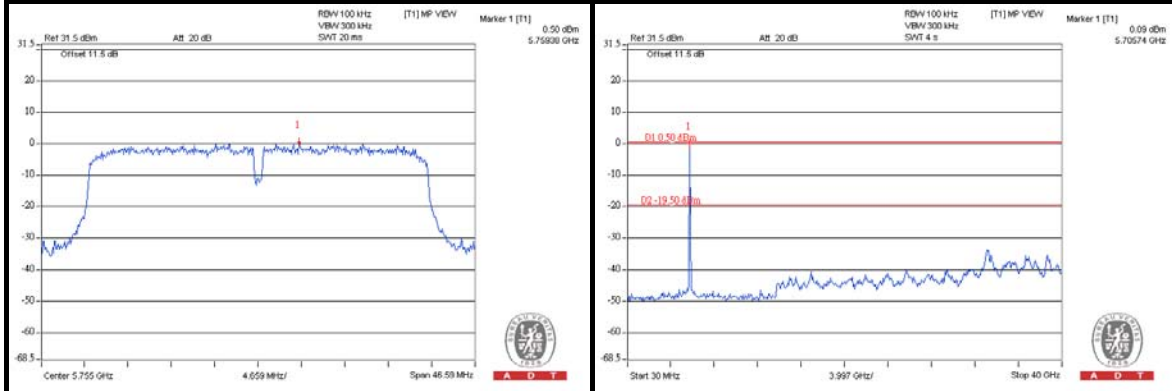

CH 159

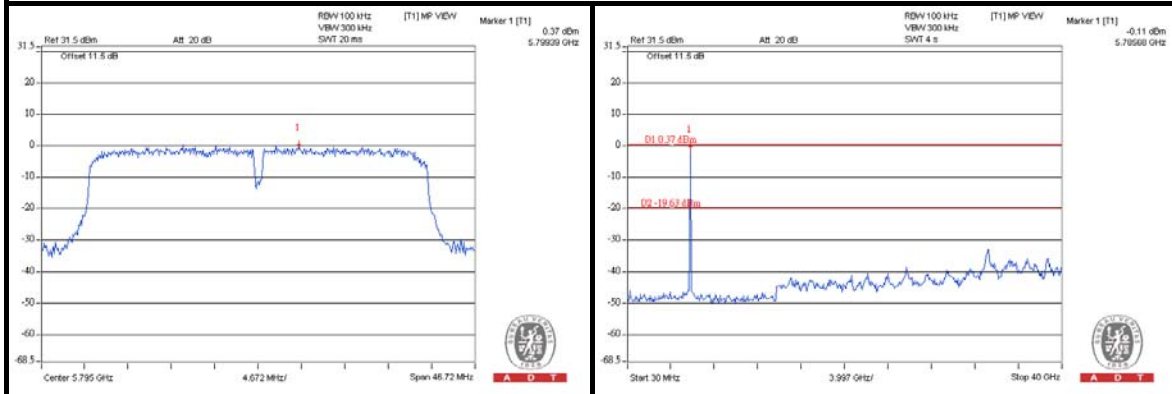



6. PHOTOGRAPHS OF THE TEST CONFIGURATION

Please refer to the attached file (Test Setup Photo).





7. INFORMATION ON THE TESTING LABORATORIES

We, Bureau Veritas Consumer Products Services (H.K.) Ltd., Taoyuan Branch, were founded in 1988 to provide our best service in EMC, Radio, Telecom and Safety consultation. Our laboratories are accredited and approved according to ISO/IEC 17025.

Copies of accreditation and authorization certificates of our laboratories obtained from approval agencies can be downloaded from our web site: www.adt.com.tw/index.5.phtml. If you have any comments, please feel free to contact us at the following:

Linko EMC/RF Lab

Tel: 886-2-26052180

Fax: 886-2-26051924

Hsin Chu EMC/RF Lab

Tel: 886-3-5935343

Fax: 886-3-5935342

Hwa Ya EMC/RF/Safety/Telecom Lab

Tel: 886-3-3183232

Fax: 886-3-3270892

Email: service.adt@tw.bureauveritas.com

Web Site: www.adt.com.tw

The address and road map of all our labs can be found in our web site also.



8. APPENDIX A - MODIFICATIONS RECORDERS FOR ENGINEERING CHANGES TO THE EUT BY THE LAB

No modifications were made to the EUT by the lab during the test.

---END---