



FCC TEST REPORT

(15.407)

REPORT NO.: RF140626C27-1
MODEL NO.: EPG5000
FCC ID: A8JEPG5000
RECEIVED: Jun. 26, 2014
TESTED: Jul. 11 ~ Jul. 30, 2014
ISSUED: Aug. 08, 2014

APPLICANT: EnGenius Technologies

ADDRESS: 1580 Scenic Avenue, Costa Mesa, CA92626

ISSUED BY: Bureau Veritas Consumer Products Services
(H.K.) Ltd., Taoyuan Branch

LAB ADDRESS: No. 47-2, 14th Ling, Chia Pau Vil., Lin Kou Dist.,
New Taipei City, Taiwan, R.O.C.

TEST LOCATION: No. 19, Hwa Ya 2nd Rd, Wen Hwa Tsuen, Kwei
Shan Hsiang, Taoyuan Hsien 333, Taiwan, R.O.C.

This report should not be used by the client to claim product certification, approval, or endorsement by TAF or any government agencies.



This report is for your exclusive use. Any copying or replication of this report to or for any other person or entity, or use of our name or trademark, is permitted only with our prior written permission. This report sets forth our findings solely with respect to the test samples identified herein. The results set forth in this report are not indicative or representative of the quality or characteristics of the lot from which a test sample was taken or any similar or identical product unless specifically and expressly noted. Our report includes all of the tests requested by you and the results thereof based upon the information that you provided to us. You have 60 days from date of issuance of this report to notify us of any material error or omission caused by our negligence, provided, however, that such notice shall be in writing and shall specifically address the issue you wish to raise. A failure to raise such issue within the prescribed time shall constitute your unqualified acceptance of the completeness of this report, the tests conducted and the correctness of the report contents. Unless specific mention, the uncertainty of measurement has been explicitly taken into account to declare the compliance or non-compliance to the specification.



TABLE OF CONTENTS

RELEASE CONTROL RECORD.....	4
1. CERTIFICATION	5
2. SUMMARY OF TEST RESULTS.....	6
2.1 MEASUREMENT UNCERTAINTY	6
3. GENERAL INFORMATION.....	7
3.1 GENERAL DESCRIPTION OF EUT.....	7
3.2 DESCRIPTION OF TEST MODES.....	9
3.2.1 TEST MODE APPLICABILITY AND TESTED CHANNEL DETAIL	10
3.3 DUTY CYCLE OF TEST SIGNAL	12
3.4 DESCRIPTION OF SUPPORT UNITS.....	13
3.4.1 CONFIGURATION OF SYSTEM UNDER TEST.....	13
3.5 GENERAL DESCRIPTION OF APPLIED STANDARDS.....	14
4. TEST TYPES AND RESULTS.....	15
4.1 RADIATED EMISSION AND BANDEDGE MEASUREMENT	15
4.1.1 LIMITS OF RADIATED EMISSION AND BANDEDGE MEASUREMENT	15
4.1.2 LIMITS OF UNWANTED EMISSION OUT OF THE RESTRICTED BANDS	15
4.1.3 TEST INSTRUMENTS	16
4.1.4 TEST PROCEDURES	17
4.1.5 DEVIATION FROM TEST STANDARD	17
4.1.6 TEST SETUP.....	18
4.1.7 EUT OPERATING CONDITION	19
4.1.8 TEST RESULTS	20
4.2 CONDUCTED EMISSION MEASUREMENT.....	39
4.2.1 LIMITS OF CONDUCTED EMISSION MEASUREMENT	39
4.2.2 TEST INSTRUMENTS	39
4.2.3 TEST PROCEDURES	40
4.2.4 DEVIATION FROM TEST STANDARD	40
4.2.5 TEST SETUP.....	40
4.2.6 EUT OPERATING CONDITIONS.....	40
4.2.7 TEST RESULTS	41
4.3 TRANSMIT POWER MEASUREMENT.....	43
4.3.1 LIMITS OF TRANSMIT POWER MEASUREMENT	43
4.3.2 TEST SETUP.....	43
4.3.3 TEST INSTRUMENTS	44
4.3.4 TEST PROCEDURE	44
4.3.5 DEVIATION FROM TEST STANDARD	44
4.3.6 EUT OPERATING CONDITIONS.....	44



A D T

4.3.7	TEST RESULTS	45
4.4	PEAK POWER SPECTRAL DENSITY MEASUREMENT.....	47
4.4.1	LIMITS OF PEAK POWER SPECTRAL DENSITY MEASUREMENT	47
4.4.2	TEST SETUP.....	47
4.4.3	TEST INSTRUMENTS	47
4.4.4	TEST PROCEDURES	47
4.4.5	DEVIATION FROM TEST STANDARD	48
4.4.6	EUT OPERATING CONDITIONS.....	48
4.4.7	TEST RESULTS	49
4.5	FREQUENCY STABILITY	55
4.5.1	LIMITS OF FREQUENCY STABILITY MEASUREMENT	55
4.5.2	TEST SETUP.....	55
4.5.3	TEST INSTRUMENTS	55
4.5.4	TEST PROCEDURE	56
4.5.5	DEVIATION FROM TEST STANDARD	56
4.5.6	EUT OPERATING CONDITION	56
4.5.7	TEST RESULTS	57
4.6	6dB BANDWIDTH MEASUREMENT	58
4.6.1	LIMITS OF 6dB BANDWIDTH MEASUREMENT.....	58
4.6.2	TEST SETUP.....	58
4.6.3	TEST INSTRUMENTS	58
4.6.4	TEST PROCEDURE	58
4.6.5	DEVIATION FROM TEST STANDARD	58
4.6.6	EUT OPERATING CONDITIONS.....	58
4.6.7	TEST RESULTS	59
5.	PHOTOGRAPHS OF THE TEST CONFIGURATION	61
6.	INFORMATION ON THE TESTING LABORATORIES.....	62
7.	APPENDIX A – MODIFICATIONS RECORDERS FOR ENGINEERING CHANGES TO THE EUT BY THE LAB	63



A D T

RELEASE CONTROL RECORD

ISSUE NO.	REASON FOR CHANGE	DATE ISSUED
RF140626C27-1	Original release	Aug. 08, 2014



1. CERTIFICATION

PRODUCT: IoT Gateway

MODEL: EPG5000

BRAND: EnGenius

APPLICANT: EnGenius Technologies

TESTED: Jul. 11 ~ Jul. 30, 2014

TEST SAMPLE: ENGINEERING SAMPLE

STANDARDS: FCC Part 15, Subpart E (Section 15.407)

ANSI C63.10-2009

The above equipment (model: EPG5000) has been tested by **Bureau Veritas Consumer Products Services (H.K.) Ltd., Taoyuan Branch**, and found compliance with the requirement of the above standards. The test record, data evaluation & Equipment Under Test (EUT) configurations represented herein are true and accurate accounts of the measurements of the sample's EMC characteristics under the conditions specified in this report.

PREPARED BY : Ivy Lin , **DATE :** Aug. 08, 2014
Ivy Lin / Specialist

APPROVED BY : Ken Liu , **DATE :** Aug. 08, 2014
Ken Liu / Senior Manager

2. SUMMARY OF TEST RESULTS

The EUT has been tested according to the following specifications:

APPLIED STANDARD: FCC PART 15, SUBPART E (SECTION 15.407)			
STANDARD SECTION	TEST TYPE	RESULT	REMARK
15.407(b)(6)	AC Power Conducted Emissions	PASS	Meet the requirement of limit. Minimum passing margin is -10.61dB at 11.13281MHz.
15.407(b) (1/2/3/4/6)	Radiated Emissions & Band Edge Measurement	PASS	Meet the requirement of limit. Minimum passing margin is -1.0dB at 5150.00MHz, 5714.00MHz, 11570.00MHz & 11650.00MHz
15.407(a)(1/2/3)	Max Average Transmit Power	PASS	Meet the requirement of limit.
15.407(a)(1/2/3)	Peak Power Spectral Density	PASS	Meet the requirement of limit.
15.407(e)	6dB bandwidth	PASS	Meet the requirement of limit. (U-NII-3 Band only)
15.407(g)	Frequency Stability	PASS	Meet the requirement of limit.
15.203	Antenna Requirement	PASS	No antenna connector is used.

2.1 MEASUREMENT UNCERTAINTY

Where relevant, the following measurement uncertainty levels have been estimated for tests performed on the EUT as specified in CISPR 16-4-2:

MEASUREMENT	FREQUENCY	UNCERTAINTY
Conducted emissions	9kHz~30MHz	2.44 dB
Radiated emissions	30MHz ~ 200MHz	3.34 dB
	200MHz ~1000MHz	3.35 dB
	1GHz ~ 18GHz	2.26 dB
	18GHz ~ 40GHz	1.94 dB

This uncertainty represents an expanded uncertainty expressed at approximately the 95% confidence level using a coverage factor of $k = 2$.

3. GENERAL INFORMATION

3.1 GENERAL DESCRIPTION OF EUT

EUT	IoT Gateway
MODEL NO.	EPG5000
POWER SUPPLY	12Vdc (Adapter)
MODULATION TYPE	256QAM, 64QAM, 16QAM, QPSK, BPSK
MODULATION TECHNOLOGY	OFDM
TRANSFER RATE	802.11a: 54.0/ 48.0/ 36.0/ 24.0/ 18.0/ 12.0/ 9.0/ 6.0Mbps 802.11n: up to 450.0Mbps 802.11ac: up to 1299.9Mbps
OPERATING FREQUENCY	5180 ~ 5240MHz & 5745 ~ 5825MHz
NUMBER OF CHANNEL	5180 ~ 5240MHz: 4 for 802.11a, 802.11n (20MHz), 802.11ac (20MHz) 2 for 802.11n (40MHz), 802.11ac (40MHz) 1 for 802.11ac (80MHz) 5745 ~ 5825MHz: 5 for 802.11a, 802.11n (20MHz), 802.11ac (20MHz) 2 for 802.11n (40MHz), 802.11ac (40MHz) 1 for 802.11ac (80MHz)
OUTPUT POWER	420.786mW for 5180 ~ 5240MHz 344.864mW for 5745 ~ 5825MHz
ANTENNA TYPE	Refer to note
ANTENNA CONNECTOR	Refer to note
DATA CABLE	NA
I/O PORTS	Refer to user's manual
ACCESSORY DEVICES	Adapter

NOTE:

1. The EUT incorporates a MIMO function. Physically, the EUT provides three completed transmitters and three receivers.

MODULATION MODE	TX FUNCTION
802.11b	3TX
802.11g	3TX
802.11a	3TX
802.11n (20MHz)	3TX
802.11n (40MHz)	3TX
802.11ac (20MHz)	3TX
802.11ac (40MHz)	3TX
802.11ac (80MHz)	3TX

* The modulation and bandwidth are similar for 802.11n mode for 20MHz / 40MHz and 802.11ac mode for 20MHz / 40MHz, therefore investigated worst case to representative mode in test report. (Final test mode refer section 3.2.1)

2. The EUT consumes power from the following adapter.

Brand	Powertron Electronics Corp.
Model	PA1024-2HUB PA1024-120HUB200
Input Power	100-240Vac, 50-60Hz, 0.6A
Output Power	12Vdc, 2.0A, 24W Max
Power Line	DC: 1.5m non-shielded cable with 1 core

3. The following antennas are provided to the EUT.

Type	Connector	Gain(dBi)		
		2400 ~ 2483.5MHz	5150 ~ 5250MHz	5725 ~ 5850MHz
PIFA	NA	4	5	5

4. The above EUT information is declared by manufacturer and for more detailed feature description, please refer to the manufacturer's specifications or user's manual.

3.2 DESCRIPTION OF TEST MODES

FOR 5180 ~ 5240MHz

4 channels are provided for 802.11a, 802.11n (20MHz), 802.11ac (20MHz):

CHANNEL	FREQUENCY	CHANNEL	FREQUENCY
36	5180 MHz	44	5220 MHz
40	5200 MHz	48	5240 MHz

2 channels are provided for 802.11n (40MHz), 802.11ac (40MHz):

CHANNEL	FREQUENCY	CHANNEL	FREQUENCY
38	5190 MHz	46	5230 MHz

1 channel is provided for 802.11ac (80MHz):

CHANNEL	FREQUENCY
42	5210MHz

FOR 5745 ~ 5825MHz:

5 channels are provided for 802.11a, 802.11n (20MHz), 802.11ac (20MHz):

CHANNEL	FREQUENCY	CHANNEL	FREQUENCY
149	5745MHz	161	5805MHz
153	5765MHz	165	5825MHz
157	5785MHz		

2 channels are provided for 802.11n (40MHz), 802.11ac (40MHz):

CHANNEL	FREQUENCY	CHANNEL	FREQUENCY
151	5755MHz	159	5795MHz

1 channel is provided for 802.11ac (80MHz):

CHANNEL	FREQUENCY
155	5775MHz

3.2.1 TEST MODE APPLICABILITY AND TESTED CHANNEL DETAIL

EUT CONFIGURE MODE	APPLICABLE TO				DESCRIPTION
	RE \geq 1G	RE<1G	PLC	APCM	
-	√	√	√	√	-

Where **RE \geq 1G**: Radiated Emission above 1GHz **RE<1G**: Radiated Emission below 1GHz
PLC: Power Line Conducted Emission **APCM**: Antenna Port Conducted Measurement

NOTE:

1. The EUT had been pre-tested on the positioned of each 3 axis. The worst case was found when positioned on **X-plane**.
2. "-" means no effect.

RADIATED EMISSION TEST (ABOVE 1GHz):

- Pre-Scan has been conducted to determine the worst-case mode from all possible combinations between available modulations, data rates and antenna ports (if EUT with antenna diversity architecture).
- Following channel(s) was (were) selected for the final test as listed below.

EUT CONFIGURE MODE	MODE	FREQ. BAND (MHz)	AVAILABLE CHANNEL	TESTED CHANNEL	MODULATION TECHNOLOGY	MODULATION TYPE	DATA RATE (Mbps)
-	802.11a	5180-5240	36 to 48	36, 40, 48	OFDM	BPSK	6.0
-	802.11n (20MHz)		36 to 48	36, 40, 48	OFDM	BPSK	7.2
-	802.11n (40MHz)		38 to 46	38, 46	OFDM	BPSK	15.0
-	802.11ac (80MHz)		42	42	OFDM	BPSK	65.0
-	802.11a	5745-5825	149 to 165	149, 157, 165	OFDM	BPSK	6.0
-	802.11n (20MHz)		149 to 165	149, 157, 165	OFDM	BPSK	7.2
-	802.11n (40MHz)		151 to 159	151, 159	OFDM	BPSK	15.0
-	802.11ac (80MHz)		155	155	OFDM	BPSK	65.0

RADIATED EMISSION TEST (BELOW 1GHz):

- Pre-Scan has been conducted to determine the worst-case mode from all possible combinations between available modulations, data rates and antenna ports (if EUT with antenna diversity architecture).
- Following channel(s) was (were) selected for the final test as listed below.

EUT CONFIGURE MODE	MODE	FREQ. BAND (MHz)	AVAILABLE CHANNEL	TESTED CHANNEL	MODULATION TECHNOLOGY	MODULATION TYPE	DATA RATE (Mbps)
-	802.11a	5180-5240, 5745-5825	36 to 48, 149 to 165	40	OFDM	BPSK	6.0

POWER LINE CONDUCTED EMISSION TEST:

- Pre-Scan has been conducted to determine the worst-case mode from all possible combinations between available modulations, data rates and antenna ports (if EUT with antenna diversity architecture).
- Following channel(s) was (were) selected for the final test as listed below.

EUT CONFIGURE MODE	MODE	FREQ. BAND (MHz)	AVAILABLE CHANNEL	TESTED CHANNEL	MODULATION TECHNOLOGY	MODULATION TYPE	DATA RATE (Mbps)
-	802.11a	5180-5240, 5745-5825	36 to 48, 149 to 165	40	OFDM	BPSK	6.0

ANTENNA PORT CONDUCTED MEASUREMENT:

- This item includes all test value of each mode, but only includes spectrum plot of worst value of each mode.
- Pre-Scan has been conducted to determine the worst-case mode from all possible combinations between available modulations, data rates and antenna ports (if EUT with antenna diversity architecture).
- Following channel(s) was (were) selected for the final test as listed below.

EUT CONFIGURE MODE	MODE	FREQ. BAND (MHz)	AVAILABLE CHANNEL	TESTED CHANNEL	MODULATION TECHNOLOGY	MODULATION TYPE	DATA RATE (Mbps)
-	802.11a	5180-5240	36 to 48	36, 40, 48	OFDM	BPSK	6.0
-	802.11n (20MHz)		36 to 48	36, 40, 48	OFDM	BPSK	7.2
-	802.11n (40MHz)		38 to 46	38, 46	OFDM	BPSK	15.0
-	802.11ac (80MHz)		42	42	OFDM	BPSK	65.0
-	802.11a	5745-5825	149 to 165	149, 157, 165	OFDM	BPSK	6.0
-	802.11n (20MHz)		149 to 165	149, 157, 165	OFDM	BPSK	7.2
-	802.11n (40MHz)		151 to 159	151, 159	OFDM	BPSK	15.0
-	802.11ac (80MHz)		155	155	OFDM	BPSK	65.0

TEST CONDITION:

APPLICABLE TO	ENVIRONMENTAL CONDITIONS	INPUT POWER	TESTED BY
RE≥1G	24deg. C, 69%RH	120Vac, 60Hz	Chris Lin
RE<1G	19deg. C, 69%RH	120Vac, 60Hz	Chris Lin
PLC	25deg. C, 70%RH	120Vac, 60Hz	Jones Chang
APCM	25deg. C, 65%RH	120Vac, 60Hz	Nick Chen

3.3 DUTY CYCLE OF TEST SIGNAL

Duty cycle of test signal is < 98 %, duty factor is required.

802.11a: Duty cycle = $2.025/2.097 = 0.966$, Duty factor = $10 * \log(1/0.966) = 0.15$

802.11n (20MHz): Duty cycle = $1.879/1.948 = 0.965$, Duty factor = $10 * \log(1/0.965) = 0.15$

802.11n (40MHz): Duty cycle = $921.0/995.0 = 0.926$, Duty factor = $10 * \log(1/0.926) = 0.33$

802.11ac (80MHz): Duty cycle = $450.0/519.0 = 0.867$, Duty factor = $10 * \log(1/0.867) = 0.62$

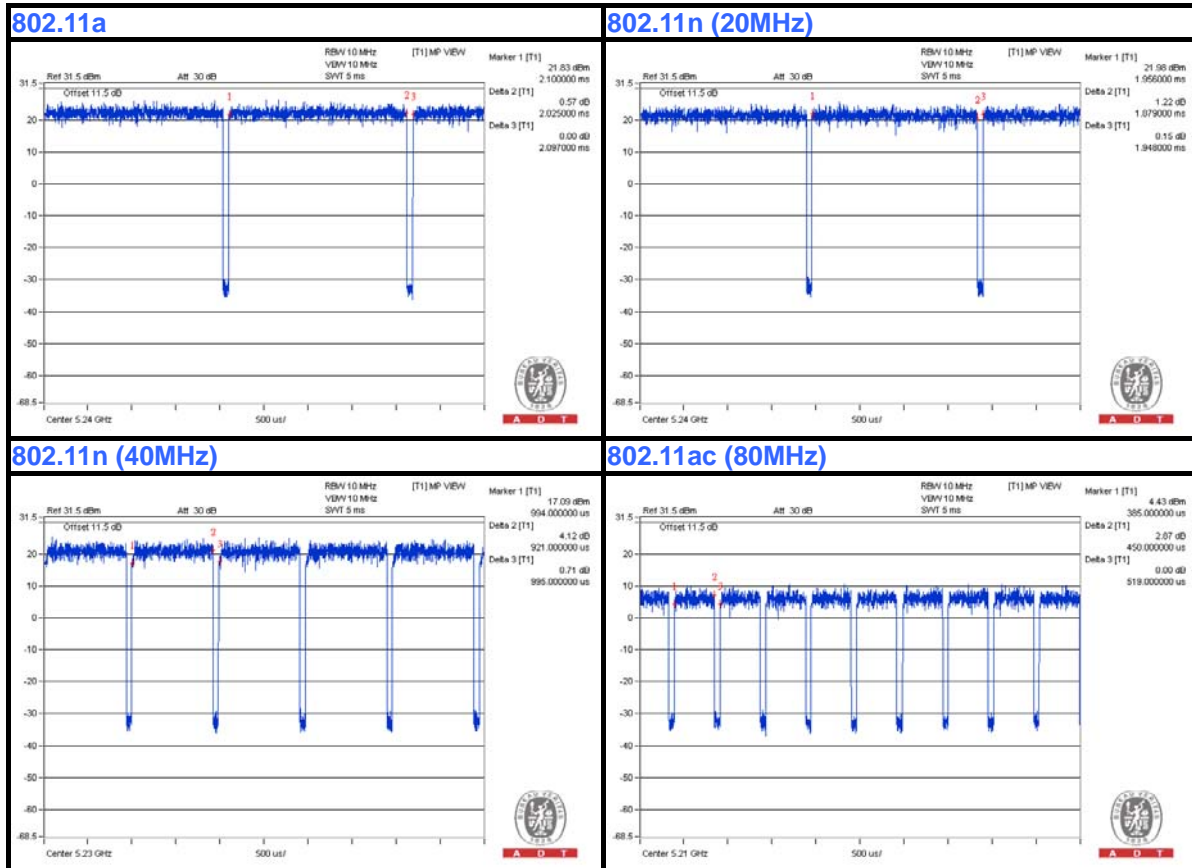

3.4 DESCRIPTION OF SUPPORT UNITS

The EUT has been tested as an independent unit together with other necessary accessories or support units. The following support units or accessories were used to form a representative test configuration during the tests.

NO.	PRODUCT	BRAND	MODEL NO.	SERIAL NO.	FCC ID
1	Notebook	DELL	E5410	1HC2XM1	FCC Doc Approved

NO.	SIGNAL CABLE DESCRIPTION OF THE ABOVE SUPPORT UNITS
1	3m LAN cable

NOTE:

1. All power cords of the above support units are non-shielded (1.8m).
2. Item 1 acted as a communication partner to transfer data.

3.4.1 CONFIGURATION OF SYSTEM UNDER TEST

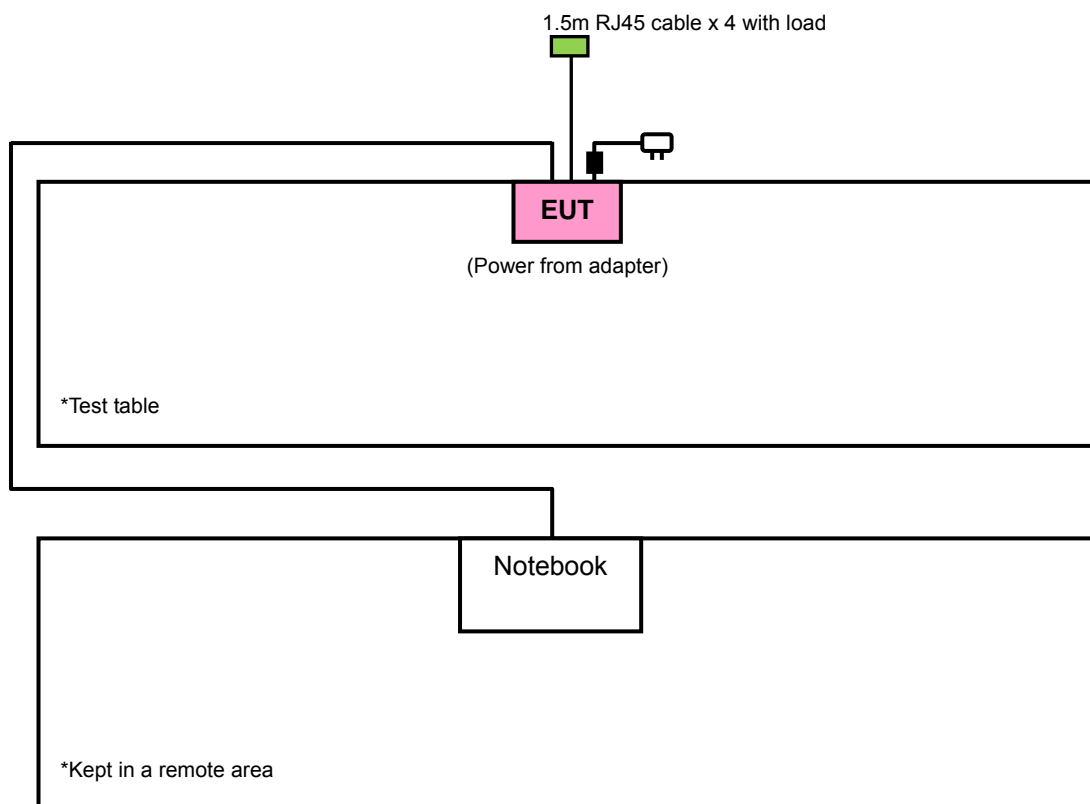

3.5 GENERAL DESCRIPTION OF APPLIED STANDARDS

The EUT is a RF Product. According to the specification of the EUT declared by the manufacturer, it must comply with the requirements of the following standards:

FCC Part 15, Subpart E (15.407)

789033 D02 General UNII Test Procedures New Rules v01

662911 D01 Multiple Transmitter Output v02r01

ANSI C63.10-2009

All test items have been performed and recorded as per the above standards.

NOTE: The EUT is also considered as a kind of computer peripheral, because the connection to computer is necessary for typical use. It has been verified to comply with the requirements of FCC Part 15, Subpart B, Class B (DoC). The test report has been issued separately.

4. TEST TYPES AND RESULTS

4.1 RADIATED EMISSION AND BANDEDGE MEASUREMENT

4.1.1 LIMITS OF RADIATED EMISSION AND BANDEDGE MEASUREMENT

Radiated emissions which fall in the restricted bands must comply with the radiated emission limits specified as below table:

FREQUENCIES (MHz)	FIELD STRENGTH (microvolts/meter)	MEASUREMENT DISTANCE (meters)
0.009 ~ 0.490	2400/F(kHz)	300
0.490 ~ 1.705	24000/F(kHz)	30
1.705 ~ 30.0	30	30
30 ~ 88	100	3
88 ~ 216	150	3
216 ~ 960	200	3
Above 960	500	3

NOTE:

1. The lower limit shall apply at the transition frequencies.
2. Emission level (dBuV/m) = 20 log Emission level (uV/m).
3. For frequencies above 1000MHz, the field strength limits are based on average detector, however, the peak field strength of any emission shall not exceed the maximum permitted average limits, specified above by more than 20dB under any condition of modulation.

4.1.2 LIMITS OF UNWANTED EMISSION OUT OF THE RESTRICTED BANDS

APPLICABLE TO	LIMIT	
789033 D02 General UNII Test Procedures New Rules v01	FIELD STRENGTH AT 3m	
	PK: 74 (dBµV/m)	AV: 54 (dBµV/m)
APPLICABLE TO	EIRP LIMIT	EQUIVALENT FIELD STRENGTH AT 3m
15.407(b)(1)	PK: -27 (dBm/MHz)	PK: 68.2 (dBµV/m)
15.407(b)(2)		
15.407(b)(3)		
15.407(b)(4)	PK: -27 (dBm/MHz) ^{*1} PK: -17 (dBm/MHz) ^{*2}	PK: 68.2 (dBµV/m) ^{*1} PK: 78.2 (dBµV/m) ^{*2}

NOTE: ^{*1} beyond 10MHz of the band edge ^{*2} within 10 MHz of band edge

The following formula is used to convert the equipment isotropic radiated power (eirp) to field strength:

$$E = \frac{1000000\sqrt{30P}}{3} \mu\text{V/m, where P is the eirp (Watts).}$$

4.1.3 TEST INSTRUMENTS

DESCRIPTION & MANUFACTURER	MODEL NO.	SERIAL NO.	DATE OF CALIBRATION	DUE DATE OF CALIBRATION
Test Receiver ROHDE & SCHWARZ	ESIB7	100187	Jan. 02, 2014	Jan. 01, 2015
Spectrum Analyzer ROHDE & SCHWARZ	FSP40	100039	Mar. 03, 2014	Mar. 02, 2015
BILOG Antenna SCHWARZBECK	VULB9168	9168-160	Feb. 26, 2014	Feb. 25, 2015
HORN Antenna SCHWARZBECK	9120D	209	Sep. 12, 2013	Sep. 11, 2014
HORN Antenna SCHWARZBECK	BBHA 9170	BBHA9170241	Feb. 17, 2014	Feb. 16, 2015
Preamplifier Agilent	8447D	2944A10633	Oct. 07, 2013	Oct. 06, 2014
Preamplifier Agilent	8449B	3008A01964	Aug. 26, 2013	Aug. 25, 2014
RF signal cable HUBER+SUHNNER	SUCOFLEX 104	214378/4	Aug. 26, 2013	Aug. 25, 2014
RF signal cable HUBER+SUHNNER	SUCOFLEX 106	12738/6 +309224/4	Aug. 26, 2013	Aug. 25, 2014
Software BV ADT	ADT_Radiated_ V7.6.15.9.4	NA	NA	NA
Antenna Tower inn-co GmbH	MA 4000	013303	NA	NA
Antenna Tower Controller inn-co GmbH	CO2000	017303	NA	NA
Turn Table BV ADT	TT100	TT93021703	NA	NA
Turn Table Controller BV ADT	SC100	SC93021703	NA	NA
26GHz ~ 40GHz Amplifier	EM26400	815221	Oct. 18, 2013	Oct. 17, 2014
High Speed Peak Power Meter	ML2495A	0824011	Jul. 26, 2014	Jul. 25, 2015
Power Sensor	MA2411B	0738171	Jul. 26, 2014	Jul. 25, 2015
WIT Standard Temperature And Humidity Chamber	TH-4S-C	W981030	Jun. 09, 2014	Jun. 08, 2015

- NOTE:**
1. The calibration interval of the above test instruments is 12 months and the calibrations are traceable to NML/ROC and NIST/USA.
 2. The test was performed in HwaYa Chamber 3.
 3. The horn antenna and HP preamplifier (model: 8449B) are used only for the measurement of emission frequency above 1GHz if tested.
 4. The FCC Site Registration No. is 988962.
 5. The IC Site Registration No. is IC 7450F-3.

4.1.4 TEST PROCEDURES

- a. The EUT was placed on the top of a rotating table 0.8 meters above the ground at a 3 meter semi-anechoic chamber. The table was rotated 360 degrees to determine the position of the highest radiation.
- b. The EUT was set 3 meters away from the interference-receiving antenna, which was mounted on the top of a variable-height antenna tower.
- c. The antenna is a broadband antenna, and its height is varied from one meter to four meters above the ground to determine the maximum value of the field strength. Both horizontal and vertical polarizations of the antenna are set to make the measurement.
- d. For each suspected emission, the EUT was arranged to its worst case and then the antenna was tuned to heights from 1 meter to 4 meters and the rotatable table was turned from 0 degrees to 360 degrees to find the maximum reading.
- e. The test-receiver system was set to Peak Detect Function and Specified Bandwidth with Maximum Hold Mode.
- f. If the emission level of the EUT in peak mode was 10dB lower than the limit specified, then testing could be stopped and the peak values of the EUT would be reported. Otherwise the emissions that did not have 10dB margin would be re-tested one by one using peak, quasi-peak or average method as specified and then reported in a data sheet.

NOTE:

1. The resolution bandwidth and video bandwidth of test receiver/spectrum analyzer is 120kHz for Quasi-peak detection at frequency below 1GHz.
2. The resolution bandwidth of test receiver/spectrum analyzer is 1MHz and video bandwidth is 3MHz for Peak detection at frequency above 1GHz.
3. The resolution bandwidth of test receiver/spectrum analyzer is 1MHz and the video bandwidth is $\geq 1/T$ (Duty cycle < 98%) or 10Hz (Duty cycle > 98%) for Average detection (AV) at frequency above 1GHz.
4. All modes of operation were investigated and the worst-case emissions are reported.

4.1.5 DEVIATION FROM TEST STANDARD

No deviation.

4.1.6 TEST SETUP

Frequency range 30MHz~1GHz

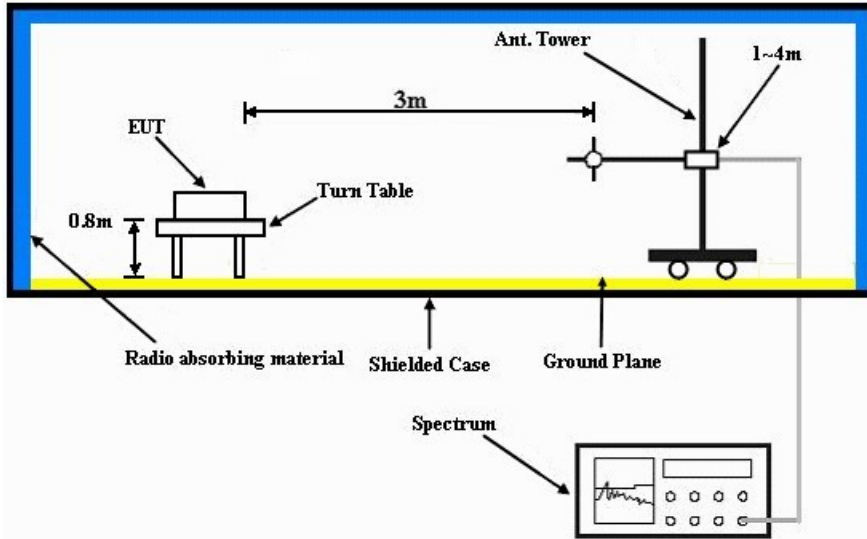

Frequency range above 1GHz

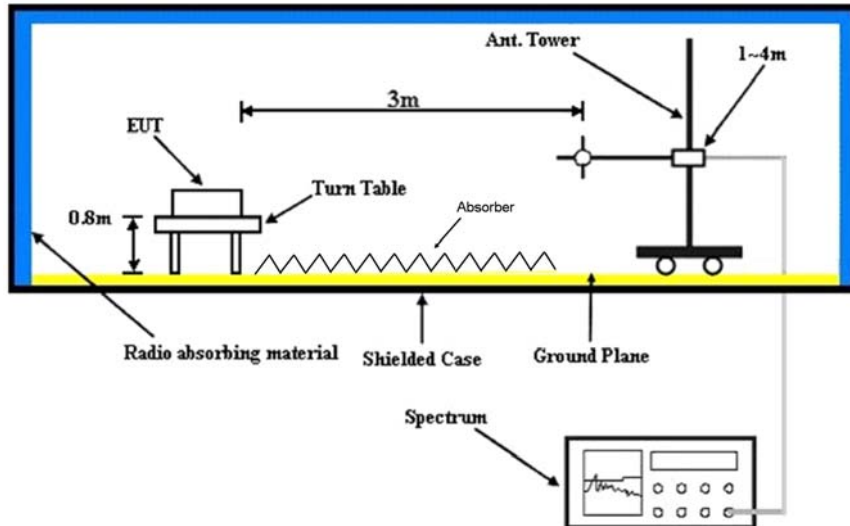

For the actual test configuration, please refer to the attached file (Test Setup Photo).

4.1.7 EUT OPERATING CONDITION

- a. Placed the EUT on the testing table.
- b. Prepared a notebook to act as a communication partner and placed it outside of testing area.
- c. The communication partner was connected with the EUT via a RJ45 cable and ran a test program (provided by manufacturer) to enable the EUT under transmission condition continuously at specific channel frequency.
- d. The communication partner sent data to EUT by command "PING".

4.1.8 TEST RESULTS

ABOVE 1GHz DATA

For U-NII-1 Band

802.11a

CHANNEL	TX Channel 36	DETECTOR FUNCTION	Peak (PK)
FREQUENCY RANGE	1GHz ~ 40GHz		Average (AV)

ANTENNA POLARITY & TEST DISTANCE: HORIZONTAL AT 3 M								
NO.	FREQ. (MHz)	EMISSION LEVEL (dBuV/m)	LIMIT (dBuV/m)	MARGIN (dB)	ANTENNA HEIGHT (m)	TABLE ANGLE (Degree)	RAW VALUE (dBuV)	CORRECTION FACTOR (dB/m)
1	5150.00	60.4 PK	74.0	-13.6	1.99 H	220	55.30	5.10
2	5150.00	47.7 AV	54.0	-6.3	1.99 H	220	42.60	5.10
3	*5180.00	112.8 PK			1.37 H	214	75.10	37.70
4	*5180.00	100.4 AV			1.37 H	214	62.70	37.70
5	#10360.00	60.7 PK	74.0	-13.3	1.28 H	297	42.40	18.30
6	#10360.00	47.3 AV	54.0	-6.7	1.28 H	297	29.00	18.30
ANTENNA POLARITY & TEST DISTANCE: VERTICAL AT 3 M								
NO.	FREQ. (MHz)	EMISSION LEVEL (dBuV/m)	LIMIT (dBuV/m)	MARGIN (dB)	ANTENNA HEIGHT (m)	TABLE ANGLE (Degree)	RAW VALUE (dBuV)	CORRECTION FACTOR (dB/m)
1	5150.00	67.4 PK	74.0	-6.6	1.00 V	202	62.30	5.10
2	5150.00	52.6 AV	54.0	-1.4	1.00 V	202	47.50	5.10
3	*5180.00	118.0 PK			1.00 V	153	80.30	37.70
4	*5180.00	105.4 AV			1.00 V	153	67.70	37.70
5	#10360.00	60.5 PK	74.0	-13.5	1.26 V	173	42.20	18.30
6	#10360.00	47.2 AV	54.0	-6.8	1.26 V	173	28.90	18.30

REMARKS:

1. Emission Level(dBuV/m) = Raw Value(dBuV) + Correction Factor(dB/m)
2. Correction Factor(dB/m) = Antenna Factor(dB/m) + Cable Factor(dB)
3. The other emission levels were very low against the limit.
4. Margin value = Emission Level – Limit value
5. " * " : Fundamental frequency.
6. " # " : The radiated frequency is out of the restricted band.

CHANNEL	TX Channel 40	DETECTOR FUNCTION	Peak (PK)
FREQUENCY RANGE	1GHz ~ 40GHz		Average (AV)

ANTENNA POLARITY & TEST DISTANCE: HORIZONTAL AT 3 M								
NO.	FREQ. (MHz)	EMISSION LEVEL (dBuV/m)	LIMIT (dBuV/m)	MARGIN (dB)	ANTENNA HEIGHT (m)	TABLE ANGLE (Degree)	RAW VALUE (dBuV)	CORRECTION FACTOR (dB/m)
1	5150.00	60.4 PK	74.0	-13.6	1.54 H	213	55.30	5.10
2	5150.00	37.4 AV	54.0	-16.6	1.54 H	213	32.30	5.10
3	*5200.00	114.4 PK			1.52 H	215	76.60	37.80
4	*5200.00	102.1 AV			1.52 H	215	64.30	37.80
5	#10400.00	60.9 PK	74.0	-13.1	1.53 H	144	42.20	18.70
6	#10400.00	48.8 AV	54.0	-5.2	1.53 H	144	30.10	18.70
7	15600.00	63.9 PK	74.0	-10.1	1.45 H	138	44.80	19.10
8	15600.00	50.5 AV	54.0	-3.5	1.45 H	138	31.40	19.10
ANTENNA POLARITY & TEST DISTANCE: VERTICAL AT 3 M								
NO.	FREQ. (MHz)	EMISSION LEVEL (dBuV/m)	LIMIT (dBuV/m)	MARGIN (dB)	ANTENNA HEIGHT (m)	TABLE ANGLE (Degree)	RAW VALUE (dBuV)	CORRECTION FACTOR (dB/m)
1	5150.00	61.8 PK	74.0	-12.2	1.00 V	337	56.70	5.10
2	5150.00	47.6 AV	54.0	-6.4	1.00 V	337	42.50	5.10
3	*5200.00	123.6 PK			1.23 V	322	85.80	37.80
4	*5200.00	110.7 AV			1.23 V	322	72.90	37.80
5	#10400.00	60.8 PK	74.0	-13.2	1.29 V	58	42.10	18.70
6	#10400.00	49.0 AV	54.0	-5.0	1.29 V	58	30.30	18.70
7	15600.00	66.4 PK	74.0	-7.6	1.26 V	56	47.30	19.10
8	15600.00	52.6 AV	54.0	-1.4	1.26 V	56	33.50	19.10

REMARKS:

1. Emission Level(dBuV/m) = Raw Value(dBuV) + Correction Factor(dB/m)
2. Correction Factor(dB/m) = Antenna Factor(dB/m) + Cable Factor(dB)
3. The other emission levels were very low against the limit.
4. Margin value = Emission Level – Limit value
5. " * ": Fundamental frequency.
6. " # ": The radiated frequency is out of the restricted band.

CHANNEL	TX Channel 48	DETECTOR FUNCTION	Peak (PK)
FREQUENCY RANGE	1GHz ~ 40GHz		Average (AV)

ANTENNA POLARITY & TEST DISTANCE: HORIZONTAL AT 3 M								
NO.	FREQ. (MHz)	EMISSION LEVEL (dBuV/m)	LIMIT (dBuV/m)	MARGIN (dB)	ANTENNA HEIGHT (m)	TABLE ANGLE (Degree)	RAW VALUE (dBuV)	CORRECTION FACTOR (dB/m)
1	*5240.00	114.6 PK			1.64 H	215	76.70	37.90
2	*5240.00	102.3 AV			1.64 H	215	64.40	37.90
3	5350.00	57.2 PK	74.0	-16.8	1.50 H	108	51.80	5.40
4	5350.00	44.7 AV	54.0	-9.3	1.50 H	108	39.30	5.40
5	#10480.00	60.5 PK	74.0	-13.5	1.13 H	100	41.00	19.50
6	#10480.00	47.7 AV	54.0	-6.3	1.13 H	100	28.20	19.50
7	15720.00	63.4 PK	74.0	-10.6	1.32 H	78	44.40	19.00
8	15720.00	50.5 AV	54.0	-3.5	1.32 H	78	31.50	19.00
ANTENNA POLARITY & TEST DISTANCE: VERTICAL AT 3 M								
NO.	FREQ. (MHz)	EMISSION LEVEL (dBuV/m)	LIMIT (dBuV/m)	MARGIN (dB)	ANTENNA HEIGHT (m)	TABLE ANGLE (Degree)	RAW VALUE (dBuV)	CORRECTION FACTOR (dB/m)
1	*5240.00	121.7 PK			1.00 V	12	83.80	37.90
2	*5240.00	109.0 AV			1.00 V	12	71.10	37.90
3	5350.00	58.1 PK	74.0	-15.9	1.00 V	161	52.70	5.40
4	5350.00	45.6 AV	54.0	-8.4	1.00 V	161	40.20	5.40
5	#10480.00	61.6 PK	74.0	-12.4	1.57 V	318	42.10	19.50
6	#10480.00	48.5 AV	54.0	-5.5	1.57 V	318	29.00	19.50
7	15720.00	66.2 PK	74.0	-7.8	1.02 V	283	47.20	19.00
8	15720.00	52.6 AV	54.0	-1.4	1.02 V	283	33.60	19.00

REMARKS:

1. Emission Level(dBuV/m) = Raw Value(dBuV) + Correction Factor(dB/m)
2. Correction Factor(dB/m) = Antenna Factor(dB/m) + Cable Factor(dB)
3. The other emission levels were very low against the limit.
4. Margin value = Emission Level – Limit value
5. " * ": Fundamental frequency.
6. " # ": The radiated frequency is out of the restricted band.



A D T

802.11n (20MHz)

CHANNEL	TX Channel 36	DETECTOR FUNCTION	Peak (PK)
FREQUENCY RANGE	1GHz ~ 40GHz		Average (AV)

ANTENNA POLARITY & TEST DISTANCE: HORIZONTAL AT 3 M								
NO.	FREQ. (MHz)	EMISSION LEVEL (dBuV/m)	LIMIT (dBuV/m)	MARGIN (dB)	ANTENNA HEIGHT (m)	TABLE ANGLE (Degree)	RAW VALUE (dBuV)	CORRECTION FACTOR (dB/m)
1	5150.00	58.5 PK	74.0	-15.5	1.24 H	224	53.40	5.10
2	5150.00	47.3 AV	54.0	-6.7	1.24 H	224	42.20	5.10
3	*5180.00	111.1 PK			1.56 H	214	73.40	37.70
4	*5180.00	102.3 AV			1.56 H	214	64.60	37.70
5	#10360.00	60.2 PK	74.0	-13.8	1.13 H	205	41.90	18.30
6	#10360.00	48.3 AV	54.0	-5.7	1.13 H	205	30.00	18.30
ANTENNA POLARITY & TEST DISTANCE: VERTICAL AT 3 M								
NO.	FREQ. (MHz)	EMISSION LEVEL (dBuV/m)	LIMIT (dBuV/m)	MARGIN (dB)	ANTENNA HEIGHT (m)	TABLE ANGLE (Degree)	RAW VALUE (dBuV)	CORRECTION FACTOR (dB/m)
1	5150.00	66.8 PK	74.0	-7.2	1.00 V	195	61.70	5.10
2	5150.00	53.0 AV	54.0	-1.0	1.00 V	195	47.90	5.10
3	*5180.00	118.8 PK			1.00 V	5	81.10	37.70
4	*5180.00	109.1 AV			1.00 V	5	71.40	37.70
5	#10360.00	61.2 PK	74.0	-12.8	1.17 V	48	42.90	18.30
6	#10360.00	49.5 AV	54.0	-4.5	1.17 V	48	31.20	18.30

REMARKS:

1. Emission Level(dBuV/m) = Raw Value(dBuV) + Correction Factor(dB/m)
2. Correction Factor(dB/m) = Antenna Factor(dB/m) + Cable Factor(dB)
3. The other emission levels were very low against the limit.
4. Margin value = Emission Level – Limit value
5. " * ": Fundamental frequency.
6. " # ": The radiated frequency is out of the restricted band.

CHANNEL	TX Channel 40	DETECTOR FUNCTION	Peak (PK)
FREQUENCY RANGE	1GHz ~ 40GHz		Average (AV)

ANTENNA POLARITY & TEST DISTANCE: HORIZONTAL AT 3 M								
NO.	FREQ. (MHz)	EMISSION LEVEL (dBuV/m)	LIMIT (dBuV/m)	MARGIN (dB)	ANTENNA HEIGHT (m)	TABLE ANGLE (Degree)	RAW VALUE (dBuV)	CORRECTION FACTOR (dB/m)
1	5150.00	57.1 PK	74.0	-16.9	1.06 H	54	52.00	5.10
2	5150.00	45.7 AV	54.0	-8.3	1.06 H	54	40.60	5.10
3	*5200.00	113.5 PK			1.70 H	216	75.70	37.80
4	*5200.00	103.1 AV			1.70 H	216	65.30	37.80
5	#10400.00	61.6 PK	74.0	-12.4	1.28 H	54	42.90	18.70
6	#10400.00	49.3 AV	54.0	-4.7	1.28 H	54	30.60	18.70
7	15600.00	63.1 PK	74.0	-10.9	1.17 H	85	44.00	19.10
8	15600.00	52.2 AV	54.0	-1.8	1.17 H	85	33.10	19.10
ANTENNA POLARITY & TEST DISTANCE: VERTICAL AT 3 M								
NO.	FREQ. (MHz)	EMISSION LEVEL (dBuV/m)	LIMIT (dBuV/m)	MARGIN (dB)	ANTENNA HEIGHT (m)	TABLE ANGLE (Degree)	RAW VALUE (dBuV)	CORRECTION FACTOR (dB/m)
1	5150.00	67.0 PK	74.0	-7.0	1.00 V	331	61.90	5.10
2	5150.00	52.3 AV	54.0	-1.7	1.00 V	331	47.20	5.10
3	*5200.00	123.5 PK			1.00 V	0	85.70	37.80
4	*5200.00	114.0 AV			1.00 V	0	76.20	37.80
5	#10400.00	60.0 PK	74.0	-14.0	1.84 V	0	41.30	18.70
6	#10400.00	49.0 AV	54.0	-5.0	1.84 V	0	30.30	18.70
7	15600.00	67.3 PK	74.0	-6.7	1.23 V	285	48.20	19.10
8	15600.00	52.3 AV	54.0	-1.7	1.23 V	285	33.20	19.10

REMARKS:

1. Emission Level(dBuV/m) = Raw Value(dBuV) + Correction Factor(dB/m)
2. Correction Factor(dB/m) = Antenna Factor(dB/m) + Cable Factor(dB)
3. The other emission levels were very low against the limit.
4. Margin value = Emission Level – Limit value
5. " * ": Fundamental frequency.
6. " # ": The radiated frequency is out of the restricted band.

CHANNEL	TX Channel 48	DETECTOR FUNCTION	Peak (PK)
FREQUENCY RANGE	1GHz ~ 40GHz		Average (AV)

ANTENNA POLARITY & TEST DISTANCE: HORIZONTAL AT 3 M								
NO.	FREQ. (MHz)	EMISSION LEVEL (dBuV/m)	LIMIT (dBuV/m)	MARGIN (dB)	ANTENNA HEIGHT (m)	TABLE ANGLE (Degree)	RAW VALUE (dBuV)	CORRECTION FACTOR (dB/m)
1	*5240.00	114.3 PK			1.50 H	216	76.40	37.90
2	*5240.00	104.7 AV			1.50 H	216	66.80	37.90
3	5350.00	48.3 PK	74.0	-25.7	1.06 H	302	42.90	5.40
4	5350.00	44.4 AV	54.0	-9.6	1.06 H	302	39.00	5.40
5	#10480.00	62.5 PK	74.0	-11.5	1.13 H	8	43.00	19.50
6	#10480.00	50.7 AV	54.0	-3.3	1.13 H	8	31.20	19.50
7	15720.00	61.9 PK	74.0	-12.1	1.33 H	69	42.90	19.00
8	15720.00	50.6 AV	54.0	-3.4	1.33 H	69	31.60	19.00

ANTENNA POLARITY & TEST DISTANCE: VERTICAL AT 3 M								
NO.	FREQ. (MHz)	EMISSION LEVEL (dBuV/m)	LIMIT (dBuV/m)	MARGIN (dB)	ANTENNA HEIGHT (m)	TABLE ANGLE (Degree)	RAW VALUE (dBuV)	CORRECTION FACTOR (dB/m)
1	*5240.00	121.8 PK			1.37 V	325	83.90	37.90
2	*5240.00	112.2 AV			1.37 V	325	74.30	37.90
3	5350.00	58.9 PK	74.0	-15.1	1.23 V	69	53.50	5.40
4	5350.00	46.0 AV	54.0	-8.0	1.23 V	69	40.60	5.40
5	#10480.00	63.0 PK	74.0	-11.0	1.16 V	58	43.50	19.50
6	#10480.00	50.1 AV	54.0	-3.9	1.16 V	58	30.60	19.50
7	15720.00	63.8 PK	74.0	-10.2	1.02 V	64	44.80	19.00
8	15720.00	52.6 AV	54.0	-1.4	1.02 V	64	33.60	19.00

REMARKS:

1. Emission Level(dBuV/m) = Raw Value(dBuV) + Correction Factor(dB/m)
2. Correction Factor(dB/m) = Antenna Factor(dB/m) + Cable Factor(dB)
3. The other emission levels were very low against the limit.
4. Margin value = Emission Level – Limit value
5. " * ": Fundamental frequency.
6. " # ": The radiated frequency is out of the restricted band.



A D T

802.11n (40MHz)

CHANNEL	TX Channel 38	DETECTOR FUNCTION	Peak (PK)
FREQUENCY RANGE	1GHz ~ 40GHz		Average (AV)

ANTENNA POLARITY & TEST DISTANCE: HORIZONTAL AT 3 M								
NO.	FREQ. (MHz)	EMISSION LEVEL (dBuV/m)	LIMIT (dBuV/m)	MARGIN (dB)	ANTENNA HEIGHT (m)	TABLE ANGLE (Degree)	RAW VALUE (dBuV)	CORRECTION FACTOR (dB/m)
1	5150.00	55.9 PK	74.0	-18.1	1.24 H	307	50.80	5.10
2	5150.00	45.8 AV	54.0	-8.2	1.24 H	307	40.70	5.10
3	*5190.00	103.4 PK			1.73 H	214	65.60	37.80
4	*5190.00	93.3 AV			1.73 H	214	55.50	37.80
5	#10380.00	60.2 PK	74.0	-13.8	1.47 H	85	41.80	18.40
6	#10380.00	50.0 AV	54.0	-4.0	1.47 H	85	31.60	18.40
ANTENNA POLARITY & TEST DISTANCE: VERTICAL AT 3 M								
NO.	FREQ. (MHz)	EMISSION LEVEL (dBuV/m)	LIMIT (dBuV/m)	MARGIN (dB)	ANTENNA HEIGHT (m)	TABLE ANGLE (Degree)	RAW VALUE (dBuV)	CORRECTION FACTOR (dB/m)
1	5150.00	64.9 PK	74.0	-9.1	1.00 V	193	59.80	5.10
2	5150.00	52.5 AV	54.0	-1.5	1.00 V	193	47.40	5.10
3	*5190.00	110.2 PK			1.10 V	8	72.40	37.80
4	*5190.00	100.3 AV			1.10 V	8	62.50	37.80
5	#10380.00	61.4 PK	74.0	-12.6	1.17 V	58	43.00	18.40
6	#10380.00	48.8 AV	54.0	-5.2	1.17 V	58	30.40	18.40

REMARKS:

1. Emission Level(dBuV/m) = Raw Value(dBuV) + Correction Factor(dB/m)
2. Correction Factor(dB/m) = Antenna Factor(dB/m) + Cable Factor(dB)
3. The other emission levels were very low against the limit.
4. Margin value = Emission Level – Limit value
5. " * ": Fundamental frequency.
6. " # ": The radiated frequency is out of the restricted band.

CHANNEL	TX Channel 46	DETECTOR FUNCTION	Peak (PK)
FREQUENCY RANGE	1GHz ~ 40GHz		Average (AV)

ANTENNA POLARITY & TEST DISTANCE: HORIZONTAL AT 3 M								
NO.	FREQ. (MHz)	EMISSION LEVEL (dBuV/m)	LIMIT (dBuV/m)	MARGIN (dB)	ANTENNA HEIGHT (m)	TABLE ANGLE (Degree)	RAW VALUE (dBuV)	CORRECTION FACTOR (dB/m)
1	5150.00	58.0 PK	74.0	-16.0	1.26 H	217	52.90	5.10
2	5150.00	47.9 AV	54.0	-6.1	1.26 H	217	42.80	5.10
3	*5230.00	110.6 PK			1.00 H	222	72.70	37.90
4	*5230.00	101.3 AV			1.00 H	222	63.40	37.90
5	5350.00	57.3 PK	74.0	-16.7	1.23 H	6	51.90	5.40
6	5350.00	45.5 AV	54.0	-8.5	1.23 H	6	40.10	5.40
7	#10460.00	60.7 PK	74.0	-13.3	1.23 H	69	41.50	19.20
8	#10460.00	49.9 AV	54.0	-4.1	1.23 H	69	30.70	19.20
ANTENNA POLARITY & TEST DISTANCE: VERTICAL AT 3 M								
NO.	FREQ. (MHz)	EMISSION LEVEL (dBuV/m)	LIMIT (dBuV/m)	MARGIN (dB)	ANTENNA HEIGHT (m)	TABLE ANGLE (Degree)	RAW VALUE (dBuV)	CORRECTION FACTOR (dB/m)
1	5150.00	64.6 PK	74.0	-9.4	1.00 V	4	59.50	5.10
2	5150.00	52.3 AV	54.0	-1.7	1.00 V	4	47.20	5.10
3	*5230.00	117.8 PK			1.00 V	15	79.90	37.90
4	*5230.00	108.2 AV			1.00 V	15	70.30	37.90
5	5350.00	57.4 PK	74.0	-16.6	1.25 V	256	52.00	5.40
6	5350.00	46.2 AV	54.0	-7.8	1.25 V	256	40.80	5.40
7	#10460.00	61.8 PK	74.0	-12.2	1.33 V	25	42.60	19.20
8	#10460.00	50.7 AV	54.0	-3.3	1.33 V	25	31.50	19.20

REMARKS:

1. Emission Level(dBuV/m) = Raw Value(dBuV) + Correction Factor(dB/m)
2. Correction Factor(dB/m) = Antenna Factor(dB/m) + Cable Factor(dB)
3. The other emission levels were very low against the limit.
4. Margin value = Emission Level – Limit value
5. " * ": Fundamental frequency.
6. " # ": The radiated frequency is out of the restricted band.



A D T

802.11ac (80MHz)

CHANNEL	TX Channel 42	DETECTOR FUNCTION	Peak (PK)
FREQUENCY RANGE	1GHz ~ 40GHz		Average (AV)

ANTENNA POLARITY & TEST DISTANCE: HORIZONTAL AT 3 M								
NO.	FREQ. (MHz)	EMISSION LEVEL (dBuV/m)	LIMIT (dBuV/m)	MARGIN (dB)	ANTENNA HEIGHT (m)	TABLE ANGLE (Degree)	RAW VALUE (dBuV)	CORRECTION FACTOR (dB/m)
1	5150.00	56.2 PK	74.0	-17.8	1.24 H	226	51.10	5.10
2	5150.00	46.3 AV	54.0	-7.7	1.24 H	226	41.20	5.10
3	*5210.00	97.6 PK			1.00 H	214	59.80	37.80
4	*5210.00	87.0 AV			1.00 H	214	49.20	37.80
5	#10420.00	61.4 PK	74.0	-12.6	1.18 H	250	42.60	18.80
6	#10420.00	48.9 AV	54.0	-5.1	1.18 H	250	30.10	18.80
ANTENNA POLARITY & TEST DISTANCE: VERTICAL AT 3 M								
NO.	FREQ. (MHz)	EMISSION LEVEL (dBuV/m)	LIMIT (dBuV/m)	MARGIN (dB)	ANTENNA HEIGHT (m)	TABLE ANGLE (Degree)	RAW VALUE (dBuV)	CORRECTION FACTOR (dB/m)
1	5150.00	65.9 PK	74.0	-8.1	1.00 V	194	60.80	5.10
2	5150.00	52.7 AV	54.0	-1.3	1.00 V	194	47.60	5.10
3	*5210.00	104.8 PK			1.24 V	5	67.00	37.80
4	*5210.00	94.0 AV			1.24 V	5	56.20	37.80
5	#10420.00	61.4 PK	74.0	-12.6	1.23 V	56	42.60	18.80
6	#10420.00	49.2 AV	54.0	-4.8	1.23 V	56	30.40	18.80

REMARKS:

1. Emission Level(dBuV/m) = Raw Value(dBuV) + Correction Factor(dB/m)
2. Correction Factor(dB/m) = Antenna Factor(dB/m) + Cable Factor(dB)
3. The other emission levels were very low against the limit.
4. Margin value = Emission Level – Limit value
5. " * ": Fundamental frequency.
6. " # ": The radiated frequency is out of the restricted band.

ABOVE 1GHz DATA

For U-NII-3 Band

802.11a

CHANNEL	TX Channel 149	DETECTOR FUNCTION	Peak (PK)
FREQUENCY RANGE	1GHz ~ 40GHz		Average (AV)

ANTENNA POLARITY & TEST DISTANCE: HORIZONTAL AT 3 M								
NO.	FREQ. (MHz)	EMISSION LEVEL (dBuV/m)	LIMIT (dBuV/m)	MARGIN (dB)	ANTENNA HEIGHT (m)	TABLE ANGLE (Degree)	RAW VALUE (dBuV)	CORRECTION FACTOR (dB/m)
1	#5714.00	59.4 PK	74.0	-14.6	1.08 H	300	53.40	6.00
2	#5714.00	46.1 AV	54.0	-7.9	1.08 H	300	40.10	6.00
3	#5722.00	65.9 PK	78.2	-12.3	1.00 H	302	59.90	6.00
4	#5725.00	52.4 PK	78.2	-25.8	1.00 H	264	46.40	6.00
5	*5745.00	109.8 PK			1.00 H	212	71.30	38.50
6	*5745.00	97.7 AV			1.00 H	212	59.20	38.50
7	11490.00	65.0 PK	74.0	-9.0	1.40 H	229	44.60	20.40
8	11490.00	51.7 AV	54.0	-2.3	1.40 H	229	31.30	20.40
ANTENNA POLARITY & TEST DISTANCE: VERTICAL AT 3 M								
NO.	FREQ. (MHz)	EMISSION LEVEL (dBuV/m)	LIMIT (dBuV/m)	MARGIN (dB)	ANTENNA HEIGHT (m)	TABLE ANGLE (Degree)	RAW VALUE (dBuV)	CORRECTION FACTOR (dB/m)
1	#5714.00	68.7 PK	74.0	-5.3	1.00 V	329	62.70	6.00
2	#5714.00	52.8 AV	54.0	-1.2	1.00 V	329	46.80	6.00
3	#5722.00	75.6 PK	78.2	-2.6	1.00 V	360	69.60	6.00
4	#5725.00	61.9 PK	78.2	-16.3	1.00 V	346	55.90	6.00
5	*5745.00	119.2 PK			1.00 V	201	80.70	38.50
6	*5745.00	105.8 AV			1.00 V	201	67.30	38.50
7	11490.00	65.6 PK	74.0	-8.4	1.52 V	20	45.20	20.40
8	11490.00	52.3 AV	54.0	-1.7	1.52 V	20	31.90	20.40

REMARKS:

1. Emission Level(dBuV/m) = Raw Value(dBuV) + Correction Factor(dB/m)
2. Correction Factor(dB/m) = Antenna Factor(dB/m) + Cable Factor(dB)
3. The other emission levels were very low against the limit.
4. Margin value = Emission Level – Limit value
5. " * ": Fundamental frequency.
6. " # ": The radiated frequency is out of the restricted band.

CHANNEL	TX Channel 157	DETECTOR FUNCTION	Peak (PK)
FREQUENCY RANGE	1GHz ~ 40GHz		Average (AV)

ANTENNA POLARITY & TEST DISTANCE: HORIZONTAL AT 3 M								
NO.	FREQ. (MHz)	EMISSION LEVEL (dBuV/m)	LIMIT (dBuV/m)	MARGIN (dB)	ANTENNA HEIGHT (m)	TABLE ANGLE (Degree)	RAW VALUE (dBuV)	CORRECTION FACTOR (dB/m)
1	*5785.00	109.8 PK			1.00 H	220	71.20	38.60
2	*5785.00	97.4 AV			1.00 H	220	58.80	38.60
3	11570.00	65.2 PK	74.0	-8.8	1.30 H	203	44.80	20.40
4	11570.00	52.1 AV	54.0	-1.9	1.30 H	203	31.70	20.40
ANTENNA POLARITY & TEST DISTANCE: VERTICAL AT 3 M								
NO.	FREQ. (MHz)	EMISSION LEVEL (dBuV/m)	LIMIT (dBuV/m)	MARGIN (dB)	ANTENNA HEIGHT (m)	TABLE ANGLE (Degree)	RAW VALUE (dBuV)	CORRECTION FACTOR (dB/m)
1	*5785.00	118.4 PK			1.00 V	200	79.80	38.60
2	*5785.00	105.8 AV			1.00 V	200	67.20	38.60
3	11570.00	66.4 PK	74.0	-7.6	1.74 V	85	46.00	20.40
4	11570.00	53.0 AV	54.0	-1.0	1.74 V	85	32.60	20.40

REMARKS:

1. Emission Level(dBuV/m) = Raw Value(dBuV) + Correction Factor(dB/m)
2. Correction Factor(dB/m) = Antenna Factor(dB/m) + Cable Factor(dB)
3. The other emission levels were very low against the limit.
4. Margin value = Emission Level – Limit value
5. " * ": Fundamental frequency.

CHANNEL	TX Channel 165	DETECTOR FUNCTION	Peak (PK)
FREQUENCY RANGE	1GHz ~ 40GHz		Average (AV)

ANTENNA POLARITY & TEST DISTANCE: HORIZONTAL AT 3 M								
NO.	FREQ. (MHz)	EMISSION LEVEL (dBuV/m)	LIMIT (dBuV/m)	MARGIN (dB)	ANTENNA HEIGHT (m)	TABLE ANGLE (Degree)	RAW VALUE (dBuV)	CORRECTION FACTOR (dB/m)
1	*5825.00	112.0 PK			1.38 H	16	73.30	38.70
2	*5825.00	99.3 AV			1.38 H	16	60.60	38.70
3	#5850.00	46.5 PK	78.2	-31.7	1.43 H	324	40.30	6.20
4	#5853.00	62.1 PK	78.2	-16.1	1.00 H	299	55.70	6.40
5	#5861.00	57.9 PK	74.0	-16.1	1.25 H	305	51.50	6.40
6	#5861.00	45.1 AV	54.0	-8.9	1.25 H	305	38.70	6.40
7	11650.00	63.1 PK	74.0	-10.9	1.50 H	55	42.80	20.30
8	11650.00	50.5 AV	54.0	-3.5	1.50 H	55	30.20	20.30

ANTENNA POLARITY & TEST DISTANCE: VERTICAL AT 3 M								
NO.	FREQ. (MHz)	EMISSION LEVEL (dBuV/m)	LIMIT (dBuV/m)	MARGIN (dB)	ANTENNA HEIGHT (m)	TABLE ANGLE (Degree)	RAW VALUE (dBuV)	CORRECTION FACTOR (dB/m)
1	*5825.00	117.4 PK			1.08 V	3	78.70	38.70
2	*5825.00	105.4 AV			1.08 V	3	66.70	38.70
3	#5850.00	66.9 PK	78.2	-11.3	1.00 V	198	60.70	6.20
4	#5853.00	69.2 PK	78.2	-9.0	1.20 V	200	62.80	6.40
5	#5861.00	67.2 PK	74.0	-6.8	1.06 V	27	60.80	6.40
6	#5861.00	50.4 AV	54.0	-3.6	1.06 V	27	44.00	6.40
7	11650.00	66.6 PK	74.0	-7.4	1.00 V	184	46.30	20.30
8	11650.00	53.0 AV	54.0	-1.0	1.00 V	184	32.70	20.30

REMARKS:

1. Emission Level(dBuV/m) = Raw Value(dBuV) + Correction Factor(dB/m)
2. Correction Factor(dB/m) = Antenna Factor(dB/m) + Cable Factor(dB)
3. The other emission levels were very low against the limit.
4. Margin value = Emission Level – Limit value
5. " * ": Fundamental frequency.
6. " # ": The radiated frequency is out of the restricted band.



A D T

802.11n (20MHz)

CHANNEL	TX Channel 149	DETECTOR FUNCTION	Peak (PK)
FREQUENCY RANGE	1GHz ~ 40GHz		Average (AV)

ANTENNA POLARITY & TEST DISTANCE: HORIZONTAL AT 3 M								
NO.	FREQ. (MHz)	EMISSION LEVEL (dBuV/m)	LIMIT (dBuV/m)	MARGIN (dB)	ANTENNA HEIGHT (m)	TABLE ANGLE (Degree)	RAW VALUE (dBuV)	CORRECTION FACTOR (dB/m)
1	#5714.00	50.6 PK	74.0	-23.4	1.28 H	223	44.60	6.00
2	#5714.00	38.0 AV	54.0	-16.0	1.28 H	223	32.00	6.00
3	#5722.00	64.4 PK	78.2	-13.8	1.25 H	218	58.40	6.00
4	#5725.00	54.4 PK	78.2	-23.8	1.00 H	217	48.40	6.00
5	*5745.00	110.6 PK			1.58 H	53	72.10	38.50
6	*5745.00	98.2 AV			1.58 H	53	59.70	38.50
7	11490.00	65.9 PK	74.0	-8.1	1.33 H	234	45.50	20.40
8	11490.00	51.3 AV	54.0	-2.7	1.33 H	234	30.90	20.40

ANTENNA POLARITY & TEST DISTANCE: VERTICAL AT 3 M								
NO.	FREQ. (MHz)	EMISSION LEVEL (dBuV/m)	LIMIT (dBuV/m)	MARGIN (dB)	ANTENNA HEIGHT (m)	TABLE ANGLE (Degree)	RAW VALUE (dBuV)	CORRECTION FACTOR (dB/m)
1	#5714.00	69.7 PK	74.0	-4.3	1.00 V	7	63.70	6.00
2	#5714.00	53.0 AV	54.0	-1.0	1.00 V	7	47.00	6.00
3	#5722.00	75.8 PK	78.2	-2.4	1.00 V	339	69.80	6.00
4	#5725.00	59.1 PK	78.2	-19.1	1.21 V	23	53.10	6.00
5	*5745.00	117.7 PK			1.00 V	330	79.20	38.50
6	*5745.00	105.6 AV			1.00 V	330	67.10	38.50
7	11490.00	63.6 PK	74.0	-10.4	1.33 V	64	43.20	20.40
8	11490.00	51.2 AV	54.0	-2.8	1.33 V	64	30.80	20.40

REMARKS:

1. Emission Level(dBuV/m) = Raw Value(dBuV) + Correction Factor(dB/m)
2. Correction Factor(dB/m) = Antenna Factor(dB/m) + Cable Factor(dB)
3. The other emission levels were very low against the limit.
4. Margin value = Emission Level – Limit value
5. " * ": Fundamental frequency.
6. " # ": The radiated frequency is out of the restricted band.

CHANNEL	TX Channel 157	DETECTOR FUNCTION	Peak (PK)
FREQUENCY RANGE	1GHz ~ 40GHz		Average (AV)

ANTENNA POLARITY & TEST DISTANCE: HORIZONTAL AT 3 M								
NO.	FREQ. (MHz)	EMISSION LEVEL (dBuV/m)	LIMIT (dBuV/m)	MARGIN (dB)	ANTENNA HEIGHT (m)	TABLE ANGLE (Degree)	RAW VALUE (dBuV)	CORRECTION FACTOR (dB/m)
1	*5785.00	113.1 PK			1.54 H	229	74.50	38.60
2	*5785.00	99.4 AV			1.54 H	229	60.80	38.60
3	11570.00	66.5 PK	74.0	-7.5	1.41 H	149	46.10	20.40
4	11570.00	52.6 AV	54.0	-1.4	1.41 H	149	32.20	20.40
ANTENNA POLARITY & TEST DISTANCE: VERTICAL AT 3 M								
NO.	FREQ. (MHz)	EMISSION LEVEL (dBuV/m)	LIMIT (dBuV/m)	MARGIN (dB)	ANTENNA HEIGHT (m)	TABLE ANGLE (Degree)	RAW VALUE (dBuV)	CORRECTION FACTOR (dB/m)
1	*5785.00	118.6 PK			1.00 V	349	80.00	38.60
2	*5785.00	105.8 AV			1.00 V	349	67.20	38.60
3	11570.00	66.9 PK	74.0	-7.1	1.32 V	17	46.50	20.40
4	11570.00	52.7 AV	54.0	-1.3	1.32 V	17	32.30	20.40

REMARKS:

1. Emission Level(dBuV/m) = Raw Value(dBuV) + Correction Factor(dB/m)
2. Correction Factor(dB/m) = Antenna Factor(dB/m) + Cable Factor(dB)
3. The other emission levels were very low against the limit.
4. Margin value = Emission Level – Limit value
5. " * ": Fundamental frequency.

CHANNEL	TX Channel 165	DETECTOR FUNCTION	Peak (PK)
FREQUENCY RANGE	1GHz ~ 40GHz		Average (AV)

ANTENNA POLARITY & TEST DISTANCE: HORIZONTAL AT 3 M								
NO.	FREQ. (MHz)	EMISSION LEVEL (dBuV/m)	LIMIT (dBuV/m)	MARGIN (dB)	ANTENNA HEIGHT (m)	TABLE ANGLE (Degree)	RAW VALUE (dBuV)	CORRECTION FACTOR (dB/m)
1	*5825.00	110.7 PK			1.56 H	212	72.00	38.70
2	*5825.00	98.7 AV			1.56 H	212	60.00	38.70
3	#5850.00	63.4 PK	78.2	-14.8	1.44 H	20	57.20	6.20
4	#5853.00	60.5 PK	78.2	-17.7	1.79 H	50	54.10	6.40
5	#5861.00	59.5 PK	74.0	-14.5	1.52 H	52	53.10	6.40
6	#5861.00	45.3 AV	54.0	-8.7	1.52 H	52	38.90	6.40
7	11650.00	64.7 PK	74.0	-9.3	1.39 H	226	44.40	20.30
8	11650.00	51.3 AV	54.0	-2.7	1.39 H	226	31.00	20.30

ANTENNA POLARITY & TEST DISTANCE: VERTICAL AT 3 M								
NO.	FREQ. (MHz)	EMISSION LEVEL (dBuV/m)	LIMIT (dBuV/m)	MARGIN (dB)	ANTENNA HEIGHT (m)	TABLE ANGLE (Degree)	RAW VALUE (dBuV)	CORRECTION FACTOR (dB/m)
1	*5825.00	118.4 PK			1.17 V	322	79.70	38.70
2	*5825.00	105.0 AV			1.17 V	322	66.30	38.70
3	#5850.00	51.7 PK	78.2	-26.5	1.25 V	47	45.50	6.20
4	#5853.00	64.4 PK	78.2	-13.8	1.36 V	29	58.00	6.40
5	#5861.00	65.7 PK	74.0	-8.3	1.18 V	10	59.30	6.40
6	#5861.00	48.5 AV	54.0	-5.5	1.18 V	10	42.10	6.40
7	11650.00	65.0 PK	74.0	-9.0	1.48 V	344	44.70	20.30
8	11650.00	52.2 AV	54.0	-1.8	1.48 V	344	31.90	20.30

REMARKS:

1. Emission Level(dBuV/m) = Raw Value(dBuV) + Correction Factor(dB/m)
2. Correction Factor(dB/m) = Antenna Factor(dB/m) + Cable Factor(dB)
3. The other emission levels were very low against the limit.
4. Margin value = Emission Level – Limit value
5. " * ": Fundamental frequency.
6. " # ": The radiated frequency is out of the restricted band.



A D T

802.11n (40MHz)

CHANNEL	TX Channel 151	DETECTOR FUNCTION	Peak (PK)
FREQUENCY RANGE	1GHz ~ 40GHz		Average (AV)

ANTENNA POLARITY & TEST DISTANCE: HORIZONTAL AT 3 M								
NO.	FREQ. (MHz)	EMISSION LEVEL (dBuV/m)	LIMIT (dBuV/m)	MARGIN (dB)	ANTENNA HEIGHT (m)	TABLE ANGLE (Degree)	RAW VALUE (dBuV)	CORRECTION FACTOR (dB/m)
1	#5714.00	66.9 PK	74.0	-7.1	1.25 H	218	60.90	6.00
2	#5714.00	51.7 AV	54.0	-2.3	1.25 H	218	45.70	6.00
3	#5722.00	71.8 PK	78.2	-6.4	1.17 H	217	65.80	6.00
4	#5725.00	56.7 PK	78.2	-21.5	1.15 H	237	50.70	6.00
5	*5755.00	107.0 PK			1.87 H	214	68.40	38.60
6	*5755.00	93.2 AV			1.87 H	214	54.60	38.60
7	11510.00	63.3 PK	74.0	-10.7	1.44 H	203	42.90	20.40
8	11510.00	50.7 AV	54.0	-3.3	1.44 H	203	30.30	20.40

ANTENNA POLARITY & TEST DISTANCE: VERTICAL AT 3 M								
NO.	FREQ. (MHz)	EMISSION LEVEL (dBuV/m)	LIMIT (dBuV/m)	MARGIN (dB)	ANTENNA HEIGHT (m)	TABLE ANGLE (Degree)	RAW VALUE (dBuV)	CORRECTION FACTOR (dB/m)
1	#5714.00	67.1 PK	74.0	-6.9	1.00 V	17	61.10	6.00
2	#5714.00	52.6 AV	54.0	-1.4	1.00 V	17	46.60	6.00
3	#5722.00	72.2 PK	78.2	-6.0	1.02 V	323	66.20	6.00
4	#5725.00	60.5 PK	78.2	-17.7	1.09 V	317	54.50	6.00
5	*5755.00	115.2 PK			1.00 V	201	76.60	38.60
6	*5755.00	100.9 AV			1.00 V	201	62.30	38.60
7	11510.00	62.4 PK	74.0	-11.6	1.43 V	19	42.00	20.40
8	11510.00	50.6 AV	54.0	-3.4	1.43 V	19	30.20	20.40

REMARKS:

1. Emission Level(dBuV/m) = Raw Value(dBuV) + Correction Factor(dB/m)
2. Correction Factor(dB/m) = Antenna Factor(dB/m) + Cable Factor(dB)
3. The other emission levels were very low against the limit.
4. Margin value = Emission Level – Limit value
5. " * ": Fundamental frequency.
6. " # ": The radiated frequency is out of the restricted band.

CHANNEL	TX Channel 159	DETECTOR FUNCTION	Peak (PK)
FREQUENCY RANGE	1GHz ~ 40GHz		Average (AV)

ANTENNA POLARITY & TEST DISTANCE: HORIZONTAL AT 3 M								
NO.	FREQ. (MHz)	EMISSION LEVEL (dBuV/m)	LIMIT (dBuV/m)	MARGIN (dB)	ANTENNA HEIGHT (m)	TABLE ANGLE (Degree)	RAW VALUE (dBuV)	CORRECTION FACTOR (dB/m)
1	*5795.00	110.1 PK			1.75 H	228	71.50	38.60
2	*5795.00	95.4 AV			1.75 H	228	56.80	38.60
3	#5850.00	60.7 PK	78.2	-17.5	1.26 H	19	54.50	6.20
4	#5853.00	61.8 PK	78.2	-16.4	1.22 H	5	55.40	6.40
5	#5861.00	61.5 PK	74.0	-12.5	1.62 H	16	55.10	6.40
6	#5861.00	47.6 AV	54.0	-6.4	1.62 H	16	41.20	6.40
7	11590.00	64.7 PK	74.0	-9.3	1.37 H	150	44.30	20.40
8	11590.00	51.8 AV	54.0	-2.2	1.37 H	150	31.40	20.40
ANTENNA POLARITY & TEST DISTANCE: VERTICAL AT 3 M								
NO.	FREQ. (MHz)	EMISSION LEVEL (dBuV/m)	LIMIT (dBuV/m)	MARGIN (dB)	ANTENNA HEIGHT (m)	TABLE ANGLE (Degree)	RAW VALUE (dBuV)	CORRECTION FACTOR (dB/m)
1	*5795.00	115.5 PK			1.00 V	352	76.90	38.60
2	*5795.00	100.9 AV			1.00 V	352	62.30	38.60
3	#5850.00	54.1 PK	78.2	-24.1	1.07 V	318	47.90	6.20
4	#5853.00	68.3 PK	78.2	-9.9	1.08 V	320	61.90	6.40
5	#5861.00	62.7 PK	74.0	-11.3	1.28 V	354	56.30	6.40
6	#5861.00	49.7 AV	54.0	-4.3	1.28 V	354	43.30	6.40
7	11590.00	66.2 PK	74.0	-7.8	1.94 V	146	45.80	20.40
8	11590.00	52.8 AV	54.0	-1.2	1.94 V	146	32.40	20.40

REMARKS:

1. Emission Level(dBuV/m) = Raw Value(dBuV) + Correction Factor(dB/m)
2. Correction Factor(dB/m) = Antenna Factor(dB/m) + Cable Factor(dB)
3. The other emission levels were very low against the limit.
4. Margin value = Emission Level – Limit value
5. " * ": Fundamental frequency.
6. " # ": The radiated frequency is out of the restricted band.

802.11ac (80MHz)

CHANNEL	TX Channel 155	DETECTOR FUNCTION	Peak (PK)
FREQUENCY RANGE	1GHz ~ 40GHz		Average (AV)

ANTENNA POLARITY & TEST DISTANCE: HORIZONTAL AT 3 M								
NO.	FREQ. (MHz)	EMISSION LEVEL (dBuV/m)	LIMIT (dBuV/m)	MARGIN (dB)	ANTENNA HEIGHT (m)	TABLE ANGLE (Degree)	RAW VALUE (dBuV)	CORRECTION FACTOR (dB/m)
1	#5714.00	66.0 PK	74.0	-8.0	1.57 H	57	60.00	6.00
2	#5714.00	50.4 AV	54.0	-3.6	1.57 H	57	44.40	6.00
3	#5722.00	66.2 PK	78.2	-12.0	1.61 H	44	60.20	6.00
4	#5725.00	50.7 PK	78.2	-27.5	1.63 H	44	44.70	6.00
5	*5775.00	97.7 PK			1.00 H	214	59.10	38.60
6	*5775.00	86.3 AV			1.00 H	214	47.70	38.60
7	#5850.00	51.0 PK	78.2	-27.2	1.37 H	52	44.80	6.20
8	#5853.00	59.6 PK	78.2	-18.6	1.53 H	70	53.20	6.40
9	#5861.00	57.5 PK	74.0	-16.5	1.62 H	62	51.10	6.40
10	#5861.00	45.6 AV	54.0	-8.4	1.62 H	62	39.20	6.40
11	11550.00	62.2 PK	74.0	-11.8	1.14 H	59	41.80	20.40
12	11550.00	48.6 AV	54.0	-5.4	1.14 H	59	28.20	20.40

ANTENNA POLARITY & TEST DISTANCE: VERTICAL AT 3 M								
NO.	FREQ. (MHz)	EMISSION LEVEL (dBuV/m)	LIMIT (dBuV/m)	MARGIN (dB)	ANTENNA HEIGHT (m)	TABLE ANGLE (Degree)	RAW VALUE (dBuV)	CORRECTION FACTOR (dB/m)
1	#5714.00	70.1 PK	74.0	-3.9	1.00 V	12	64.10	6.00
2	#5714.00	52.5 AV	54.0	-1.5	1.00 V	12	46.50	6.00
3	#5722.00	72.0 PK	78.2	-6.2	1.46 V	26	66.00	6.00
4	#5725.00	57.4 PK	78.2	-20.8	1.31 V	32	51.40	6.00
5	*5775.00	106.8 PK			1.09 V	13	68.20	38.60
6	*5775.00	90.3 AV			1.09 V	13	51.70	38.60
7	#5850.00	53.5 PK	78.2	-24.7	1.57 V	180	47.30	6.20
8	#5853.00	60.4 PK	78.2	-17.8	1.17 V	203	54.00	6.40
9	#5861.00	60.4 PK	74.0	-13.6	1.00 V	202	54.00	6.40
10	#5861.00	47.2 AV	54.0	-6.8	1.00 V	202	40.80	6.40
11	11550.00	60.9 PK	74.0	-13.1	1.27 V	311	40.50	20.40
12	11550.00	48.4 AV	54.0	-5.6	1.27 V	311	28.00	20.40

REMARKS:

1. Emission Level(dBuV/m) = Raw Value(dBuV) + Correction Factor(dB/m)
2. Correction Factor(dB/m) = Antenna Factor(dB/m) + Cable Factor(dB)
3. The other emission levels were very low against the limit.
4. Margin value = Emission Level – Limit value
5. " * ": Fundamental frequency.
6. " # ": The radiated frequency is out of the restricted band.

BELOW 1GHz WORST-CASE DATA

802.11a

CHANNEL	TX Channel 40	DETECTOR FUNCTION	Quasi-Peak (QP)
FREQUENCY RANGE	30MHz ~ 1GHz		

ANTENNA POLARITY & TEST DISTANCE: HORIZONTAL AT 3 M								
NO.	FREQ. (MHz)	EMISSION LEVEL (dBuV/m)	LIMIT (dBuV/m)	MARGIN (dB)	ANTENNA HEIGHT (m)	TABLE ANGLE (Degree)	RAW VALUE (dBuV)	CORRECTION FACTOR (dB/m)
1	57.12	31.8 QP	40.0	-8.2	2.00 H	266	46.40	-14.60
2	212.66	36.2 QP	43.5	-7.3	1.00 H	196	52.50	-16.30
3	280.71	35.6 QP	46.0	-10.4	1.00 H	89	48.20	-12.60
4	624.85	40.4 QP	46.0	-5.6	1.50 H	198	45.90	-5.50
5	751.23	42.7 QP	46.0	-3.3	1.00 H	16	45.70	-3.00
6	961.21	42.8 QP	54.0	-11.2	1.24 H	216	42.10	0.70
ANTENNA POLARITY & TEST DISTANCE: VERTICAL AT 3 M								
NO.	FREQ. (MHz)	EMISSION LEVEL (dBuV/m)	LIMIT (dBuV/m)	MARGIN (dB)	ANTENNA HEIGHT (m)	TABLE ANGLE (Degree)	RAW VALUE (dBuV)	CORRECTION FACTOR (dB/m)
1	47.40	33.3 QP	40.0	-6.7	1.00 V	266	47.90	-14.60
2	70.73	33.1 QP	40.0	-6.9	1.00 V	121	49.30	-16.20
3	125.17	31.7 QP	43.5	-11.8	1.24 V	343	47.50	-15.80
4	624.85	36.4 QP	46.0	-9.6	1.24 V	116	41.90	-5.50
5	751.23	42.1 QP	46.0	-3.9	1.24 V	88	45.10	-3.00
6	961.21	46.3 QP	54.0	-7.7	1.00 V	12	45.60	0.70

REMARKS:

1. Emission Level(dBuV/m) = Raw Value(dBuV) + Correction Factor(dB/m)
2. Correction Factor(dB/m) = Antenna Factor(dB/m) + Cable Factor(dB)
3. The other emission levels were very low against the limit.
4. Margin value = Emission Level – Limit value

4.2 CONDUCTED EMISSION MEASUREMENT

4.2.1 LIMITS OF CONDUCTED EMISSION MEASUREMENT

FREQUENCY OF EMISSION (MHz)	CONDUCTED LIMIT (dB μ V)	
	Quasi-peak	Average
0.15 ~ 0.5	66 to 56	56 to 46
0.5 ~ 5	56	46
5 ~ 30	60	50

- NOTE:**
1. The lower limit shall apply at the transition frequencies.
 2. The limit decreases in line with the logarithm of the frequency in the range of 0.15 to 0.50MHz.
 3. All emanations from a class A/B digital device or system, including any network of conductors and apparatus connected thereto, shall not exceed the level of field strengths specified above.

4.2.2 TEST INSTRUMENTS

DESCRIPTION & MANUFACTURER	MODEL NO.	SERIAL NO.	DATE OF CALIBRATION	DUE DATE OF CALIBRATION
Test Receiver ROHDE & SCHWARZ	ESCS30	100288	Apr. 24, 2014	Apr. 23, 2015
RF signal cable Woken	5D-FB	Cable-HYCO2-01	Dec. 27, 2013	Dec. 26, 2014
LISN ROHDE & SCHWARZ (EUT)	ESH2-Z5	100100	Dec. 23, 2013	Dec. 22, 2014
LISN ROHDE & SCHWARZ (Peripheral)	ESH3-Z5	100312	Jul. 10, 2014	Jul. 09, 2015
Software ADT	BV ADT_Cond_ V7.3.7.3	NA	NA	NA

- Notes:
1. The calibration interval of the above test instruments is 12 months and the calibrations are traceable to NML/ROC and NIST/USA.
 2. The test was performed in HwaYa Shielded Room 2.
 3. The VCCI Site Registration No. is C-2047.

4.2.3 TEST PROCEDURES

- a. The EUT was placed 0.4 meters from the conducting wall of the shielded room with EUT being connected to the power mains through a line impedance stabilization network (LISN). Other support units were connected to the power mains through another LISN. The two LISNs provide 50 ohm/ 50uH of coupling impedance for the measuring instrument.
- b. Both lines of the power mains connected to the EUT were checked for maximum conducted interference.
- c. The frequency range from 150kHz to 30MHz was searched. Emission levels under (Limit - 20dB) were not recorded.

NOTE: All modes of operation were investigated and the worst-case emissions are reported.

4.2.4 DEVIATION FROM TEST STANDARD

No deviation.

4.2.5 TEST SETUP

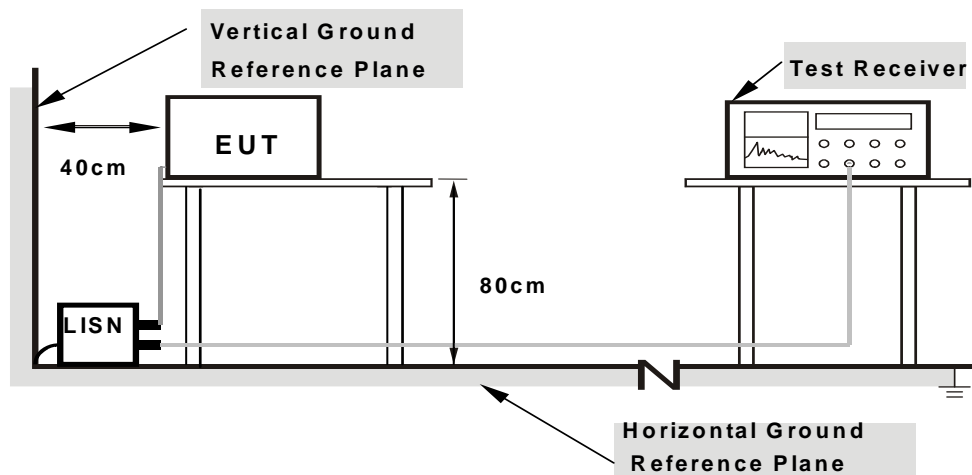

- Note:**
1. Support units were connected to second LISN.
 2. Both of LISNs (AMN) are 80 cm from EUT and at least 80 from other units and other metal planes

For the actual test configuration, please refer to the attached file (Test Setup Photo).

4.2.6 EUT OPERATING CONDITIONS

Same as 4.1.6.

4.2.7 TEST RESULTS

CONDUCTED WORST-CASE DATA: 802.11a

PHASE	Line 1	6dB BANDWIDTH	9kHz
-------	--------	---------------	------

No	Freq. [MHz]	Corr. Factor (dB)	Reading Value		Emission Level		Limit		Margin	
			[dB (uV)]		[dB (uV)]		[dB (uV)]		(dB)	
			Q.P.	AV.	Q.P.	AV.	Q.P.	AV.	Q.P.	AV.
1	0.15000	0.21	52.65	35.06	52.86	35.27	66.00	56.00	-13.14	-20.73
2	0.16953	0.22	49.84	34.83	50.06	35.05	64.98	54.98	-14.92	-19.93
3	0.23203	0.24	40.95	26.23	41.19	26.47	62.38	52.38	-21.19	-25.91
4	0.47813	0.23	39.31	33.08	39.54	33.31	56.37	46.37	-16.83	-13.06
5	4.62109	0.45	36.01	28.19	36.46	28.64	56.00	46.00	-19.54	-17.36
6	11.13281	0.53	44.01	38.86	44.54	39.39	60.00	50.00	-15.46	-10.61

REMARKS:

1. Q.P. and AV. are abbreviations of quasi-peak and average individually.
2. The emission levels of other frequencies were very low against the limit.
3. Margin value = Emission level - Limit value
4. Correction factor = Insertion loss + Cable loss
5. Emission Level = Correction Factor + Reading Value

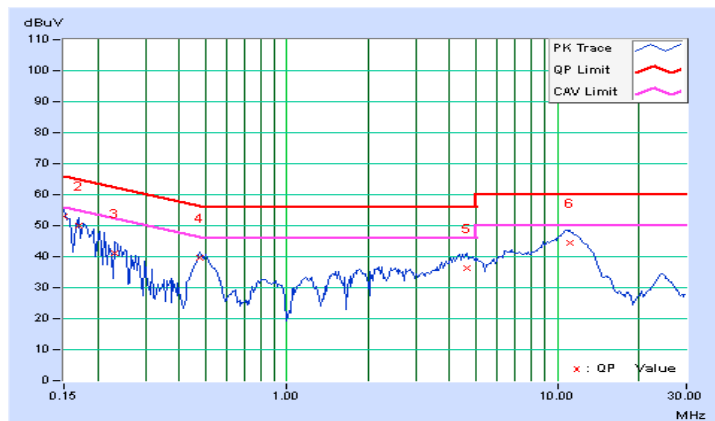

PHASE	Line 2	6dB BANDWIDTH	9kHz
-------	--------	---------------	------

No	Freq. [MHz]	Corr. Factor (dB)	Reading Value		Emission Level		Limit		Margin	
			[dB (uV)]		[dB (uV)]		[dB (uV)]		(dB)	
			Q.P.	AV.	Q.P.	AV.	Q.P.	AV.	Q.P.	AV.
1	0.15000	0.23	52.15	34.34	52.38	34.57	66.00	56.00	-13.62	-21.43
2	0.16953	0.23	49.46	34.67	49.69	34.90	64.98	54.98	-15.29	-20.08
3	0.21641	0.24	43.64	29.52	43.88	29.76	62.96	52.96	-19.07	-23.19
4	0.48594	0.30	41.61	34.00	41.91	34.30	56.24	46.24	-14.33	-11.94
5	1.92188	0.38	32.53	26.28	32.91	26.66	56.00	46.00	-23.09	-19.34
6	11.18750	0.60	39.18	34.23	39.78	34.83	60.00	50.00	-20.22	-15.17

REMARKS:

1. Q.P. and AV. are abbreviations of quasi-peak and average individually.
2. The emission levels of other frequencies were very low against the limit.
3. Margin value = Emission level - Limit value
4. Correction factor = Insertion loss + Cable loss
5. Emission Level = Correction Factor + Reading Value

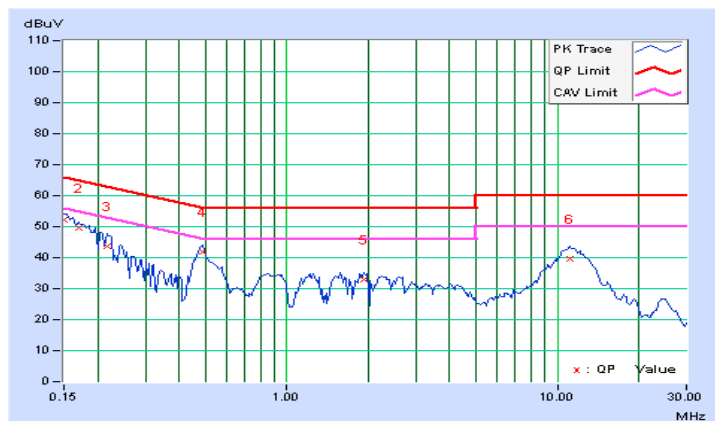

4.3 TRANSMIT POWER MEASUREMENT

4.3.1 LIMITS OF TRANSMIT POWER MEASUREMENT

Operation Band	EUT Category		LIMIT
U-NII-1		Outdoor Access Point	1 Watt (30 dBm) (Max. e.i.r.p \leq 125mW(21 dBm) at any elevation angle above 30 degrees as measured from the horizon)
		Fixed point-to-point Access Point	1 Watt (30 dBm)
	√	Indoor Access Point	1 Watt (30 dBm)
		Mobile and Portable client device	250mW (24 dBm)
U-NII-2A		---	250mW (24 dBm) or 11 dBm+10 log B*
U-NII-2C		---	250mW (24 dBm) or 11 dBm+10 log B*
U-NII-3	√	---	1 Watt (30 dBm)

*B is the 26 dB emission bandwidth in megahertz

Per KDB 662911 D01 Multiple Transmitter Output v02r01 Method of conducted output power measurement on IEEE 802.11 devices,

Array Gain = 0 dB (i.e., no array gain) for NANT \leq 4;

Array Gain = 0 dB (i.e., no array gain) for channel widths \geq 40 MHz for any NANT;

Array Gain = 5 log(NANT/NSS) dB or 3 dB, whichever is less for 20-MHz channel widths with NANT \geq 5.

For power measurements on all other devices: Array Gain = 10 log(NANT/NSS) dB.

4.3.2 TEST SETUP

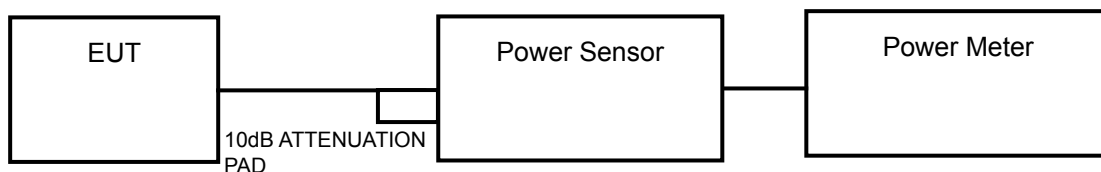

4.3.3 TEST INSTRUMENTS

Refer to section 4.1.3 to get information of above instrument.

4.3.4 TEST PROCEDURE

FOR AVERAGE POWER MEASUREMENT

For 802.11a, 802.11n (20MHz), 802.11n (40MHz)

Method PM is used to perform output power measurement, trigger and gating function of wide band power meter is enabled to measure max output power of TX on burst. Duty factor is not added to measured value.

For 802.11ac (80MHz)

- 1) Set span to encompass the entire 26 dB EBW (or, alternatively, the entire 99% occupied bandwidth) of the signal.
- 2) Set sweep trigger to “free run”.
- 3) Set RBW = 1 MHz.
- 4) Set VBW \geq 3 MHz
- 5) Number of points in sweep \geq 2 Span / RBW.
- 6) Sweep time \leq (number of points in sweep) * T
- 7) Detector = RMS.
- 8) Trace mode = max hold.
- 9) Allow max hold to run for at least 60 seconds, or longer as needed to allow the trace to stabilize.

4.3.5 DEVIATION FROM TEST STANDARD

No deviation.

4.3.6 EUT OPERATING CONDITIONS

The software provided by client to enable the EUT under transmission condition continuously at specific channel frequencies individually.

4.3.7 TEST RESULTS

POWER OUTPUT:

802.11a

CHAN.	CHAN. FREQ. (MHz)	MAXIMUM CONDUCTED POWER (dBm)			TOTAL POWER (mW)	TOTAL POWER (dBm)	POWER LIMIT (dBm)	PASS / FAIL
		CHAIN 0	CHAIN 1	CHAIN 2				
36	5180	19.29	20.75	19.71	297.309	24.73	30	PASS
40	5200	19.95	21.78	21.12	378.936	25.79	30	PASS
48	5240	19.93	21.58	20.92	365.876	25.63	30	PASS
149	5745	18.75	20.57	19.33	274.718	24.39	30	PASS
157	5785	19.44	20.06	19.32	274.800	24.39	30	PASS
165	5825	20.64	21.15	19.79	341.475	25.33	30	PASS

802.11n (20MHz)

CHAN.	CHAN. FREQ. (MHz)	MAXIMUM CONDUCTED POWER (dBm)			TOTAL POWER (mW)	TOTAL POWER (dBm)	POWER LIMIT (dBm)	PASS / FAIL
		CHAIN 0	CHAIN 1	CHAIN 2				
36	5180	19.05	21.01	19.71	300.077	24.77	30	PASS
40	5200	19.80	21.71	20.94	367.916	25.66	30	PASS
48	5240	19.86	21.48	20.79	357.383	25.53	30	PASS
149	5745	18.64	19.95	19.47	260.481	24.16	30	PASS
157	5785	20.43	21.04	20.31	344.864	25.38	30	PASS
165	5825	20.40	20.69	19.85	323.473	25.10	30	PASS



A D T

802.11n (40MHz)

CHAN.	CHAN. FREQ. (MHz)	MAXIMUM CONDUCTED POWER (dBm)			TOTAL POWER (mW)	TOTAL POWER (dBm)	POWER LIMIT (dBm)	PASS / FAIL
		CHAIN 0	CHAIN 1	CHAIN 2				
38	5190	12.83	12.45	11.89	52.219	17.18	30	PASS
46	5230	20.85	22.50	20.84	420.786	26.24	30	PASS
151	5755	18.27	20.00	19.17	249.747	23.98	30	PASS
159	5795	20.15	20.70	19.75	315.41	24.99	30	PASS

802.11ac (80MHz)

CHAN.	CHAN. FREQ. (MHz)	MAXIMUM CONDUCTED POWER (dBm)			TOTAL POWER (mW)	TOTAL POWER (dBm)	POWER LIMIT (dBm)	PASS / FAIL
		CHAIN 0	CHAIN 1	CHAIN 2				
42	5210	10.31	12.15	11.47	41.174	16.15	30	PASS
155	5775	12.34	13.52	12.79	58.642	17.68	30	PASS

4.4 PEAK POWER SPECTRAL DENSITY MEASUREMENT

4.4.1 LIMITS OF PEAK POWER SPECTRAL DENSITY MEASUREMENT

Operation Band	EUT Category		LIMIT
U-NII-1		Outdoor Access Point	17dBm/ MHz
		Fixed point-to-point Access Point	
	√	Indoor Access Point	
		Mobile and Portable client device	
U-NII-2A		---	11dBm/ MHz
U-NII-2C		---	11dBm/ MHz
U-NII-3	√	---	30dBm/ MHz

4.4.2 TEST SETUP



4.4.3 TEST INSTRUMENTS

Refer to section 4.1.3 to get information of above instrument.

4.4.4 TEST PROCEDURES

For U-NII-1 band:

Using method SA-2 alternative

- 1) Set span to encompass the entire emission bandwidth (EBW) of the signal.
- 2) Set RBW = 30 kHz, Set VBW ≥ 1 MHz, Detector = RMS
- 3) Set Channel power measure = 1MHz
- 4) Sweep time = 20 ms.
- 5) Perform a single sweep.
- 6) Record the max value and add 10 log (1/duty cycle)

For U-NII-3 band:

- 1) Set span to encompass the entire emission bandwidth (EBW) of the signal.
- 2) Set RBW = 300 kHz, Set VBW = 1 RBW, Detector = RMS
- 3) Sweep time = 100 ms.
- 4) Trace average at least 100 traces in power averaging mode.
- 5) Record the max value and add $10 \log (1/\text{duty cycle})$
- 6) Scale the observed power level to an equivalent value in 500 kHz by adjusting (reducing) the measured power by a bandwidth correction factor (BWCF) where
$$\text{BWCF} = 10 \log(500 \text{ kHz}/300 \text{ kHz})$$

4.4.5 DEVIATION FROM TEST STANDARD

No deviation.

4.4.6 EUT OPERATING CONDITIONS

Same as 4.3.6.

4.4.7 TEST RESULTS

802.11a

CHAN.	CHAN. FREQ. (MHz)	PSD (dBm)			TOTAL PSD W/O DUTY FACTOR (dBm)	DUTY FACTOR	TOTAL PSD WITH DUTY FACTOR (dBm)	MAX. LIMIT (dBm)	PASS / FAIL
		CHAIN 0	CHAIN 1	CHAIN 2					
36	5180	6.08	8.21	7.75	12.21	0.15	12.36	13.23	PASS
40	5200	7.33	8.21	7.57	12.49	0.15	12.64	13.23	PASS
48	5240	7.48	8.72	7.20	12.62	0.15	12.77	13.23	PASS

NOTE:

1. Method 1 of power density measurement of KDB 662911 is using for calculating total power density. Total power density is summing entire spectra across corresponding frequency bins on the various outputs by computer.
2. Directional gain = $5\text{dBi} + 10\log(3) = 9.77\text{dBi} > 6\text{dBi}$, so the power density limit shall be reduced to $17-(9.77-6) = 13.23\text{dBm}$.
3. Refer to section 3.3 for duty cycle spectrum plot.

802.11n (20MHz)

CHAN.	CHAN. FREQ. (MHz)	PSD (dBm)			TOTAL PSD W/O DUTY FACTOR (dBm)	DUTY FACTOR	TOTAL PSD WITH DUTY FACTOR (dBm)	MAX. LIMIT (dBm)	PASS / FAIL
		CHAIN 0	CHAIN 1	CHAIN 2					
36	5180	6.21	7.78	7.38	11.94	0.15	12.09	13.23	PASS
40	5200	7.32	8.82	8.06	12.88	0.15	13.03	13.23	PASS
48	5240	7.02	8.32	7.86	12.54	0.15	12.69	13.23	PASS

NOTE:

1. Method 1 of power density measurement of KDB 662911 is using for calculating total power density. Total power density is summing entire spectra across corresponding frequency bins on the various outputs by computer.
2. Directional gain = $5\text{dBi} + 10\log(3) = 9.77\text{dBi} > 6\text{dBi}$, so the power density limit shall be reduced to $17-(9.77-6) = 13.23\text{dBm}$.
3. Refer to section 3.3 for duty cycle spectrum plot.



802.11n (40MHz)

CHAN.	CHAN. FREQ. (MHz)	PSD (dBm)			TOTAL PSD W/O DUTY FACTOR (dBm)	DUTY FACTOR	TOTAL PSD WITH DUTY FACTOR (dBm)	MAX. LIMIT (dBm)	PASS / FAIL
		CHAIN 0	CHAIN 1	CHAIN 2					
38	5190	-3.99	-1.81	-3.45	1.79	0.33	2.12	13.23	PASS
46	5230	5.61	7.15	5.46	10.91	0.33	11.24	13.23	PASS

NOTE:

1. Method 1 of power density measurement of KDB 662911 is using for calculating total power density. Total power density is summing entire spectra across corresponding frequency bins on the various outputs by computer.
2. Directional gain = $5\text{dBi} + 10\log(3) = 9.77\text{dBi} > 6\text{dBi}$, so the power density limit shall be reduced to $17-(9.77-6) = 13.23\text{dBm}$.
3. Refer to section 3.3 for duty cycle spectrum plot.

802.11ac (80MHz)

CHAN.	CHAN. FREQ. (MHz)	PSD (dBm)			TOTAL PSD W/O DUTY FACTOR (dBm)	DUTY FACTOR	TOTAL PSD WITH DUTY FACTOR (dBm)	MAX. LIMIT (dBm)	PASS / FAIL
		CHAIN 0	CHAIN 1	CHAIN 2					
42	5210	-8.83	-8.19	-9.26	-3.97	0.62	-3.35	13.23	PASS

NOTE:

1. Method 1 of power density measurement of KDB 662911 is using for calculating total power density. Total power density is summing entire spectra across corresponding frequency bins on the various outputs by computer.
2. Directional gain = $5\text{dBi} + 10\log(3) = 9.77\text{dBi} > 6\text{dBi}$, so the power density limit shall be reduced to $17-(9.77-6) = 13.23\text{dBm}$.
3. Refer to section 3.3 for duty cycle spectrum plot.



A D T

SPECTRUM PLOT OF WORST VALUE

802.11a

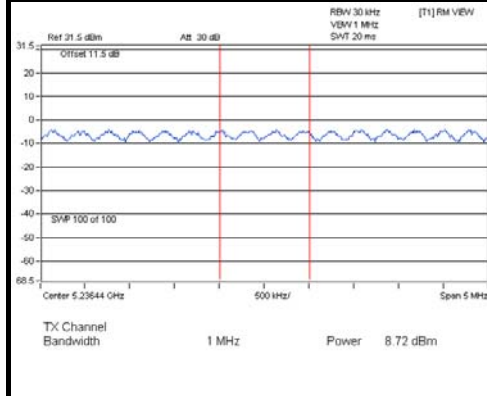

802.11n (20MHz)

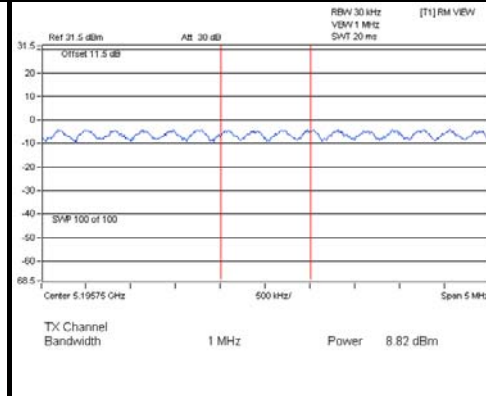

802.11n (40MHz)

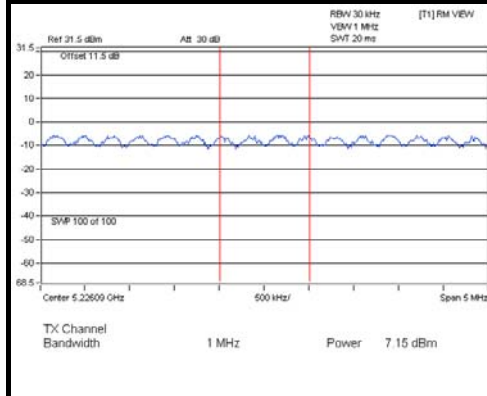

802.11ac (80MHz)

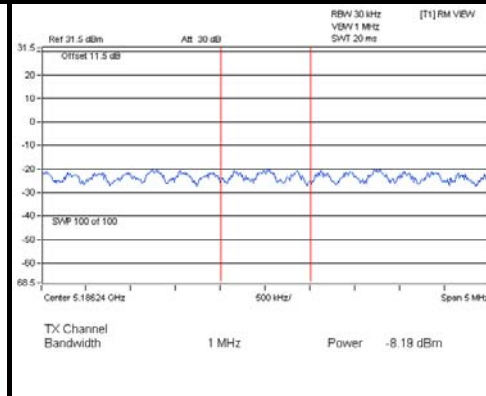

For U-NII-3 Band

802.11a

TX chain	Channel	Freq. (MHz)	PSD (dBm/300 kHz)	PSD (dBm/500 kHz)	10 log (N=3) dB	Duty Factor	Total PSD (dBm/500kHz)	Limit (dBm/500kHz)	PASS /FAIL
0	149	5745	-2.41	-0.19	4.77	0.15	4.73	26.23	PASS
	157	5785	-1.82	0.40	4.77	0.15	5.32	26.23	PASS
	165	5825	-0.65	1.57	4.77	0.15	6.49	26.23	PASS
1	149	5745	-0.22	2.00	4.77	0.15	6.92	26.23	PASS
	157	5785	-0.72	1.50	4.77	0.15	6.42	26.23	PASS
	165	5825	0.24	2.46	4.77	0.15	7.38	26.23	PASS
2	149	5745	-1.62	0.60	4.77	0.15	5.52	26.23	PASS
	157	5785	-1.57	0.65	4.77	0.15	5.57	26.23	PASS
	165	5825	-1.07	1.15	4.77	0.15	6.07	26.23	PASS

NOTE: Directional gain = 5dBi + 10log(3) = 9.77dBi > 6dBi, so the power density limit shall be reduced to 30-(9.77-6) = 26.23dBm.

802.11n (20MHz)

TX chain	Channel	Freq. (MHz)	PSD (dBm/300 kHz)	PSD (dBm/500 kHz)	10 log (N=3) dB	Duty Factor	Total PSD (dBm/500kHz)	Limit (dBm/500kHz)	PASS /FAIL
0	149	5745	-2.84	-0.62	4.77	0.15	4.30	26.23	PASS
	157	5785	-1.48	0.74	4.77	0.15	5.66	26.23	PASS
	165	5825	-1.42	0.80	4.77	0.15	5.72	26.23	PASS
1	149	5745	-0.88	1.34	4.77	0.15	6.26	26.23	PASS
	157	5785	0.02	2.24	4.77	0.15	7.16	26.23	PASS
	165	5825	-0.73	1.49	4.77	0.15	6.41	26.23	PASS
2	149	5745	-1.89	0.33	4.77	0.15	5.25	26.23	PASS
	157	5785	-0.69	1.53	4.77	0.15	6.45	26.23	PASS
	165	5825	-1.59	0.63	4.77	0.15	5.55	26.23	PASS

NOTE: Directional gain = 5dBi + 10log(3) = 9.77dBi > 6dBi, so the power density limit shall be reduced to 30-(9.77-6) = 26.23dBm.

802.11n (40MHz)

TX chain	Channel	Freq. (MHz)	PSD (dBm/300 kHz)	PSD (dBm/500 kHz)	10 log (N=3) dB	Duty Factor	Total PSD (dBm/500kHz)	Limit (dBm/500kHz)	PASS /FAIL
0	151	5755	-6.76	-4.54	4.77	0.33	0.56	26.23	PASS
	159	5795	-5.00	-2.78	4.77	0.33	2.32	26.23	PASS
1	151	5755	-4.97	-2.75	4.77	0.33	2.35	26.23	PASS
	159	5795	-4.19	-1.97	4.77	0.33	3.13	26.23	PASS
2	151	5755	-5.69	-3.47	4.77	0.33	1.63	26.23	PASS
	159	5795	-5.02	-2.80	4.77	0.33	2.30	26.23	PASS

NOTE: Directional gain = 5dBi + 10log(3) = 9.77dBi > 6dBi, so the power density limit shall be reduced to 30-(9.77-6) = 26.23dBm.

802.11ac (80MHz)

TX chain	Channel	Freq. (MHz)	PSD (dBm/300 kHz)	PSD (dBm/500 kHz)	10 log (N=3) dB	Duty Factor	Total PSD (dBm/500kHz)	Limit (dBm/500kHz)	PASS /FAIL
0	155	5775	-5.52	-3.30	4.77	0.62	2.09	26.23	PASS
1	155	5775	-14.39	-12.17	4.77	0.62	-6.78	26.23	PASS
2	155	5775	-14.97	-12.75	4.77	0.62	-7.36	26.23	PASS

NOTE: Directional gain = 5dBi + 10log(3) = 9.77dBi > 6dBi, so the power density limit shall be reduced to 30-(9.77-6) = 26.23dBm.



A D T

SPECTRUM PLOT OF WORST VALUE

802.11a

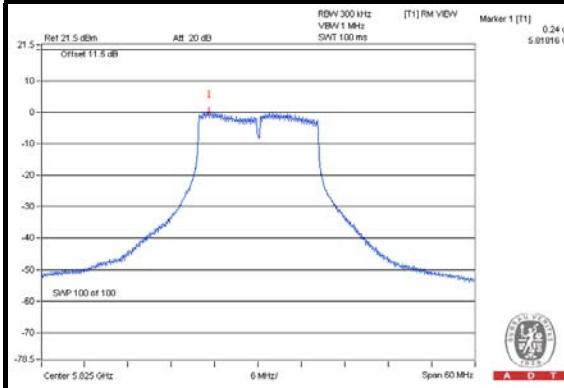

802.11n (20MHz)

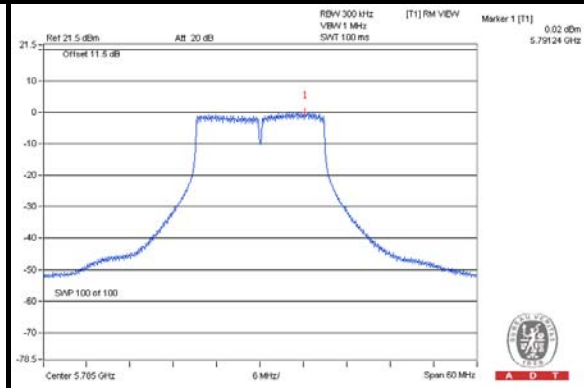

802.11n (40MHz)

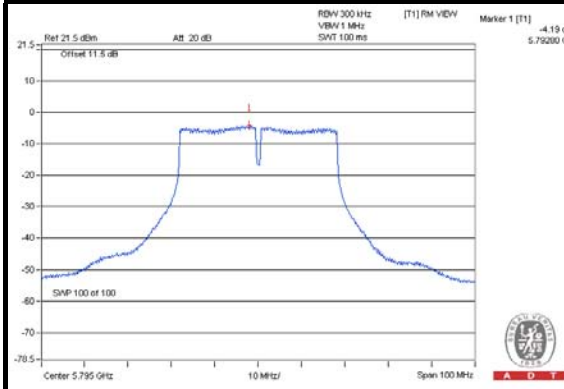

802.11ac (80MHz)

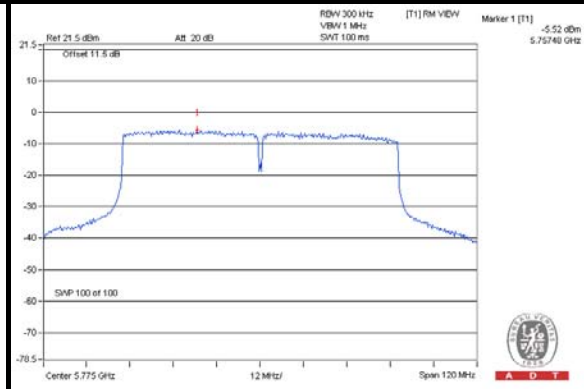

4.5 FREQUENCY STABILITY

4.5.1 LIMITS OF FREQUENCY STABILITY MEASUREMENT

The frequency of the carrier signal shall be maintained within band of operation

4.5.2 TEST SETUP

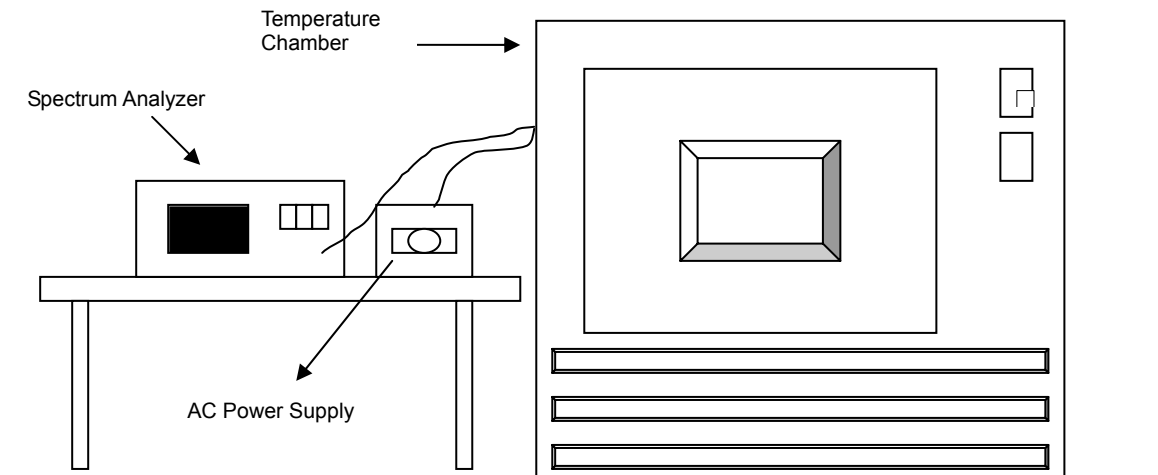

4.5.3 TEST INSTRUMENTS

Refer to section 4.1.3 to get information of above instrument.

4.5.4 TEST PROCEDURE

- a. The EUT was placed inside the environmental test chamber and powered by nominal AC voltage.
- b. Turn the EUT on and couple its output to a spectrum analyzer.
- c. Turn the EUT off and set the chamber to the highest temperature specified.
- d. Allow sufficient time (approximately 30 min) for the temperature of the chamber to stabilize, turn the EUT on and measure the operating frequency after 2, 5, and 10 minutes.
- e. Repeat step 2 and 3 with the temperature chamber set to the lowest temperature.
- f. The test chamber was allowed to stabilize at +20 degree C for a minimum of 30 minutes. The supply voltage was then adjusted on the EUT from 85% to 115% and the frequency record.

4.5.5 DEVIATION FROM TEST STANDARD

No deviation.

4.5.6 EUT OPERATING CONDITION

Set the EUT transmit at un-modulation mode to test frequency stability.



4.5.7 TEST RESULTS

FREQUENCY STABILITY VERSUS TEMP.									
OPERATING FREQUENCY: 5240MHz									
TEMP. (°C)	POWER SUPPLY (Vac)	0 MINUTE		2 MINUTE		5 MINUTE		10 MINUTE	
		Measured Frequency (MHz)	Frequency Drift (%)	Measured Frequency (MHz)	Frequency Drift (%)	Measured Frequency (MHz)	Frequency Drift (%)	Measured Frequency (MHz)	Frequency Drift (%)
50	120	5240.0036	0.00007	5240.0055	0.00010	5240.0049	0.00009	5240.0054	0.00010
40	120	5240.0188	0.00036	5240.0184	0.00035	5240.0191	0.00036	5240.0233	0.00044
30	120	5239.9883	-0.00022	5239.9886	-0.00022	5239.9847	-0.00029	5239.9859	-0.00027
20	120	5239.9846	-0.00029	5239.9838	-0.00031	5239.9867	-0.00025	5239.9843	-0.00030
10	120	5240.0061	0.00012	5240.0048	0.00009	5240.0063	0.00012	5240.0075	0.00014
0	120	5239.9940	-0.00011	5239.9969	-0.00006	5239.9950	-0.00010	5239.9955	-0.00009
-10	120	5239.9990	-0.00002	5240.0014	0.00003	5239.9984	-0.00003	5240.0007	0.00001
-20	120	5240.0071	0.00014	5240.0107	0.00020	5240.0091	0.00017	5240.0097	0.00019
-30	120	5239.9900	-0.00019	5239.9864	-0.00026	5239.9894	-0.00020	5239.9867	-0.00025

FREQUENCY STABILITY VERSUS TEMP.									
OPERATING FREQUENCY: 5240MHz									
TEMP. (°C)	POWER SUPPLY (Vac)	0 MINUTE		2 MINUTE		5 MINUTE		10 MINUTE	
		Measured Frequency (MHz)	Frequency Drift (%)	Measured Frequency (MHz)	Frequency Drift (%)	Measured Frequency (MHz)	Frequency Drift (%)	Measured Frequency (MHz)	Frequency Drift (%)
20	138	5239.9837	-0.00031	5239.9842	-0.00030	5239.9868	-0.00025	5239.9839	-0.00031
	120	5239.9846	-0.00029	5239.9838	-0.00031	5239.9867	-0.00025	5239.9843	-0.00030
	102	5239.9850	-0.00029	5239.9846	-0.00029	5239.9871	-0.00025	5239.9839	-0.00031

4.6 6dB BANDWIDTH MEASUREMENT

4.6.1 LIMITS OF 6dB BANDWIDTH MEASUREMENT

The minimum of 6dB Bandwidth Measurement is 0.5MHz.

4.6.2 TEST SETUP

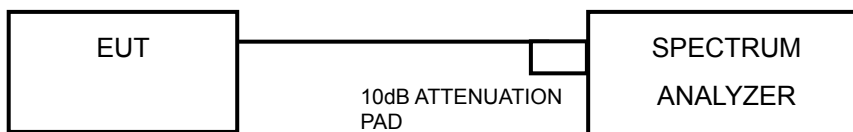

4.6.3 TEST INSTRUMENTS

Refer to section 4.1.2 to get information of above instrument.

4.6.4 TEST PROCEDURE

- a. Set resolution bandwidth (RBW) = 100kHz
- b. Set the video bandwidth (VBW) $\geq 3 \times$ RBW, Detector = Peak.
- c. Trace mode = max hold.
- d. Sweep = auto couple.
- e. Measure the maximum width of the emission that is constrained by the frequencies associated with the two amplitude points (upper and lower) that are attenuated by 6 dB relative to the maximum level measured in the fundamental emission

4.6.5 DEVIATION FROM TEST STANDARD

No deviation.

4.6.6 EUT OPERATING CONDITIONS

The software provided by client to enable the EUT under transmission condition continuously at lowest, middle and highest channel frequencies individually.

4.6.7 TEST RESULTS

802.11a

CHANNEL	FREQUENCY (MHz)	6dB BANDWIDTH (MHz)			MINIMUM LIMIT (MHz)	PASS / FAIL
		CHAIN 0	CHAIN 1	CHAIN 2		
149	5745	16.41	16.41	16.46	0.5	PASS
157	5785	16.44	16.47	16.45	0.5	PASS
165	5825	16.44	16.39	16.42	0.5	PASS

802.11n (20MHz)

CHANNEL	FREQUENCY (MHz)	6dB BANDWIDTH (MHz)			MINIMUM LIMIT (MHz)	PASS / FAIL
		CHAIN 0	CHAIN 1	CHAIN 2		
149	5745	17.65	17.65	17.66	0.5	PASS
157	5785	17.64	17.63	17.67	0.5	PASS
165	5825	17.61	17.64	17.64	0.5	PASS

802.11n (40MHz)

CHANNEL	FREQUENCY (MHz)	6dB BANDWIDTH (MHz)			MINIMUM LIMIT (MHz)	PASS / FAIL
		CHAIN 0	CHAIN 1	CHAIN 2		
151	5755	36.44	36.49	36.43	0.5	PASS
159	5795	36.45	36.48	36.44	0.5	PASS

802.11ac (80MHz)

CHANNEL	FREQUENCY (MHz)	6dB BANDWIDTH (MHz)			MINIMUM LIMIT (MHz)	PASS / FAIL
		CHAIN 0	CHAIN 1	CHAIN 2		
155	5775	75.28	76.48	75.93	0.5	PASS



A D T

SPECTRUM PLOT OF WORST VALUE

802.11a

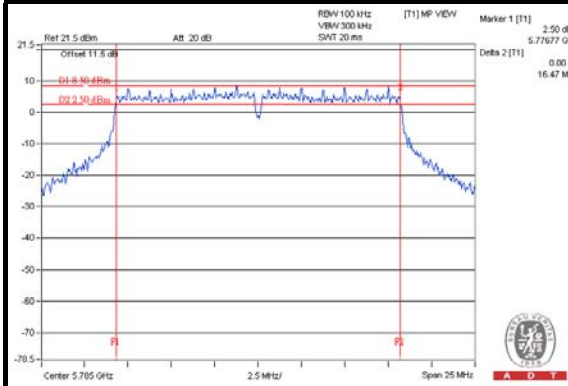

802.11n (20MHz)

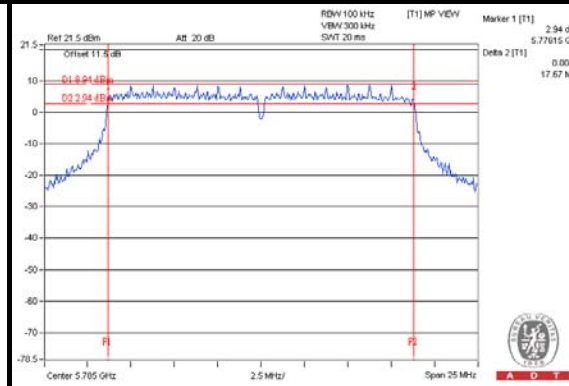

802.11n (40MHz)

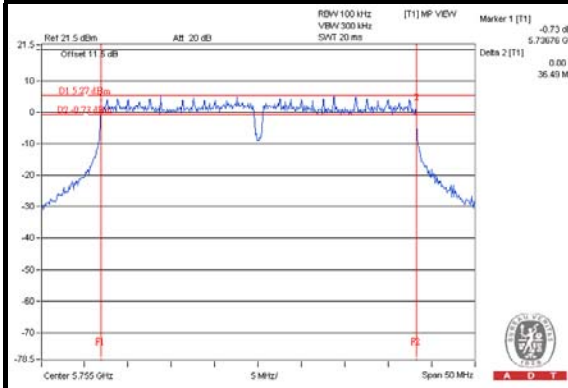

802.11ac (80MHz)

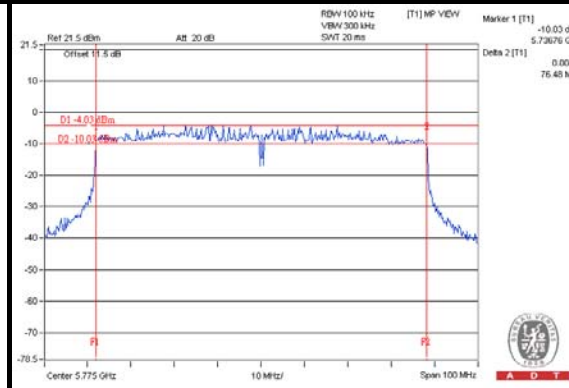

5. PHOTOGRAPHS OF THE TEST CONFIGURATION

Please refer to the attached file (Test Setup Photo).



6. INFORMATION ON THE TESTING LABORATORIES

We, Bureau Veritas Consumer Products Services (H.K.) Ltd., Taoyuan Branch, were founded in 1988 to provide our best service in EMC, Radio, Telecom and Safety consultation. Our laboratories are accredited and approved according to ISO/IEC 17025.

If you have any comments, please feel free to contact us at the following:

Linko EMC/RF Lab:

Tel: 886-2-26052180

Fax: 886-2-26051924

Hsin Chu EMC/RF Lab:

Tel: 886-3-5935343

Fax: 886-3-5935342

Hwa Ya EMC/RF/Safety Telecom Lab:

Tel: 886-3-3183232

Fax: 886-3-3270892

Email: service.adt@tw.bureauveritas.com

Web Site: www.bureauveritas-adt.com

The address and road map of all our labs can be found in our web site also.

7. APPENDIX A – MODIFICATIONS RECORDERS FOR ENGINEERING CHANGES TO THE EUT BY THE LAB

No modifications were made to the EUT by the lab during the test.

---END---