

## FCC Test Report

**Report No.:** RF150915C22

**FCC ID:** A8J-EWS500AP

**Test Model:** EWS500AP

**Received Date:** Sep. 15, 2015

**Test Date:** Sep. 17 ~ Sep. 24, 2015

**Issued Date:** Oct. 08, 2015

**Applicant:** EnGenius Technologies

**Address:** 1580 Scenic Avenue, Costa Mesa, CA92626

**Issued By:** Bureau Veritas Consumer Products Services (H.K.) Ltd., Taoyuan Branch

**Lab Address:** No. 47-2, 14th Ling, Chia Pau Vil., Lin Kou Dist., New Taipei City, Taiwan

**Test Location:** No. 19, Hwa Ya 2nd Rd., Wen Hwa Vil., Kwei Shan Dist., Taoyuan City 33383, TAIWAN (R.O.C.)



This report is for your exclusive use. Any copying or replication of this report to or for any other person or entity, or use of our name or trademark, is permitted only with our prior written permission. This report sets forth our findings solely with respect to the test samples identified herein. The results set forth in this report are not indicative or representative of the quality or characteristics of the lot from which a test sample was taken or any similar or identical product unless specifically and expressly noted. Our report includes all of the tests requested by you and the results thereof based upon the information that you provided to us. You have 60 days from date of issuance of this report to notify us of any material error or omission caused by our negligence, provided, however, that such notice shall be in writing and shall specifically address the issue you wish to raise. A failure to raise such issue within the prescribed time shall constitute your unqualified acceptance of the completeness of this report, the tests conducted and the correctness of the report contents. Unless specific mention, the uncertainty of measurement has been explicitly taken into account to declare the compliance or non-compliance to the specification. The report must not be used by the client to claim product certification, approval, or endorsement by TAF or any government agencies.



## Table of Contents

<b>Release Control Record</b> .....	<b>4</b>
<b>1 Certificate of Conformity</b> .....	<b>5</b>
<b>2 Summary of Test Results</b> .....	<b>6</b>
2.1 Measurement Uncertainty.....	6
2.2 Modification Record.....	6
<b>3 General Information</b> .....	<b>7</b>
3.1 General Description of EUT.....	7
3.2 Description of Test Modes.....	8
3.2.1 Test Mode Applicability and Tested Channel Detail.....	9
3.3 Duty Cycle of Test Signal.....	11
3.4 Description of Support Units.....	12
3.4.1 Configuration of System under Test.....	12
3.5 General Description of Applied Standards.....	13
<b>4 Test Types and Results</b> .....	<b>14</b>
4.1 Radiated Emission and Bandedge Measurement.....	14
4.1.1 Limits of Radiated Emission and Bandedge Measurement.....	14
4.1.2 Test Instruments.....	15
4.1.3 Test Procedures.....	16
4.1.4 Deviation from Test Standard.....	16
4.1.5 Test Set Up.....	17
4.1.6 EUT Operating Conditions.....	18
4.1.7 Test Results.....	19
4.2 Conducted Emission Measurement.....	33
4.2.1 Limits of Conducted Emission Measurement.....	33
4.2.2 Test Instruments.....	33
4.2.3 Test Procedures.....	33
4.2.4 Deviation from Test Standard.....	33
4.2.5 Test Setup.....	34
4.2.6 EUT Operating Conditions.....	34
4.2.7 Test Results.....	35
4.3 6dB Bandwidth Measurement.....	39
4.3.1 Limits of 6dB Bandwidth Measurement.....	39
4.3.2 Test Setup.....	39
4.3.3 Test Instruments.....	39
4.3.4 Test Procedure.....	39
4.3.5 Deviation from Test Standard.....	39
4.3.6 EUT Operating Conditions.....	39
4.3.7 Test Result.....	40
4.4 Conducted Output Power Measurement.....	42
4.4.1 Limits of Conducted Output Power Measurement.....	42
4.4.2 Test Setup.....	42
4.4.3 Test Instruments.....	42
4.4.4 Test Procedures.....	42
4.4.5 Deviation from Test Standard.....	42
4.4.6 EUT Operating Conditions.....	42
4.4.7 Test Results.....	43
4.5 Power Spectral Density Measurement.....	45
4.5.1 Limits of Power Spectral Density Measurement.....	45
4.5.2 Test Setup.....	45
4.5.3 Test Instruments.....	45
4.5.4 Test Procedure.....	45
4.5.5 Deviation from Test Standard.....	45
4.5.6 EUT Operating Condition.....	45



4.5.7 Test Results .....	46
4.6 Conducted Out of Band Emission Measurement.....	48
4.6.1 Limits of Conducted Out of Band Emission Measurement .....	48
4.6.2 Test Setup.....	48
4.6.3 Test Instruments .....	48
4.6.4 Test Procedure .....	48
4.6.5 Deviation from Test Standard .....	48
4.6.6 EUT Operating Condition .....	48
4.6.7 Test Results .....	48
<b>5 Pictures of Test Arrangements.....</b>	<b>57</b>
<b>Appendix – Information on the Testing Laboratories .....</b>	<b>58</b>



A D T

### Release Control Record

Issue No.	Description	Date Issued
RF150915C22	Original release.	Oct. 08, 2015

## 1 Certificate of Conformity

**Product:** Wireless N300 Managed Wall Plate Access Point

**Brand:**

**EnGenius**<sup>®</sup>

**Test Model:** EWS500AP

**Sample Status:** Engineering sample

**Applicant:** EnGenius Technologies

**Test Date:** Sep. 17 ~ Sep. 24, 2015

**Standards:** 47 CFR FCC Part 15, Subpart C (Section 15.247)  
ANSI C63.10:2013

The above equipment has been tested by **Bureau Veritas Consumer Products Services (H.K.) Ltd., Taoyuan Branch**, and found compliance with the requirement of the above standards. The test record, data evaluation & Equipment Under Test (EUT) configurations represented herein are true and accurate accounts of the measurements of the sample's EMC characteristics under the conditions specified in this report.

**Prepared by :** , **Date:** Oct. 08, 2015  
Pettie Chen / Senior Specialist

**Approved by :** , **Date:** Oct. 08, 2015  
Ken Liu / Senior Manager

## 2 Summary of Test Results

47 CFR FCC Part 15, Subpart C (SECTION 15.247)			
FCC Clause	Test Item	Result	Remarks
15.207	AC Power Conducted Emission	PASS	Meet the requirement of limit. Minimum passing margin is -6.88dB at 2.90594MHz.
15.205 / 15.209 / 15.247(d)	Radiated Emissions and Band Edge Measurement	PASS	Meet the requirement of limit. Minimum passing margin is -1.0dB at 2390.00, 2483.50, 4924.00MHz.
15.247(d)	Antenna Port Emission	PASS	Meet the requirement of limit.
15.247(a)(2)	6dB bandwidth	PASS	Meet the requirement of limit.
15.247(b)	Conducted power	PASS	Meet the requirement of limit.
15.247(e)	Power Spectral Density	PASS	Meet the requirement of limit.
15.203	Antenna Requirement	PASS	Antenna connector is IPEX not a standard connector.

### 2.1 Measurement Uncertainty

Where relevant, the following measurement uncertainty levels have been estimated for tests performed on the EUT as specified in CISPR 16-4-2:

Measurement	Frequency	Expanded Uncertainty (k=2) (±)
Conducted Emissions at mains ports	150kHz ~ 30MHz	2.44 dB
Radiated Emissions up to 1 GHz	30MHz ~ 200MHz	3.86 dB
	200MHz ~ 1000MHz	3.87 dB
Radiated Emissions above 1 GHz	1GHz ~ 18GHz	2.29 dB
	18GHz ~ 40GHz	2.29 dB

### 2.2 Modification Record

There were no modifications required for compliance.

### 3 General Information

#### 3.1 General Description of EUT

Product	Wireless N300 Managed Wall Plate Access Point
Brand	
Test Model	EWS500AP
Status of EUT	Engineering sample
Power Supply Rating	48Vdc (adapter) 48Vdc (PoE)
Modulation Type	CCK, DQPSK, DBPSK for DSSS 64QAM, 16QAM, QPSK, BPSK for OFDM
Modulation Technology	DSSS, OFDM
Transfer Rate	802.11b: 11.0/ 5.5/ 2.0/ 1.0Mbps 802.11g: 54.0/ 48.0/ 36.0/ 24.0/ 18.0/ 12.0/ 9.0/ 6.0Mbps 802.11n: up to 300.0Mbps
Operating Frequency	2412 ~ 2462MHz
Number of Channel	11 for 802.11b, 802.11g, 802.11n (HT20) 7 for 802.11n (HT40)
Output Power	504.637mW
Antenna Type	Refer to Note
Antenna Connector	Refer to Note
Accessory Device	NA
Data Cable Supplied	NA

**Note:**

- The EUT incorporates a MIMO function. Physically, the EUT provides two completed transmitters and two receivers.

Modulation Mode	TX Function
802.11b	2TX
802.11g	2TX
802.11n (HT20)	2TX
802.11n (HT40)	2TX

- The EUT uses following adapter and PoE. (Support unit only)

Adapter	
Brand	Powertron Electronics Corp.
Model	PA1040-480IB080
Input Power	100-240Vac~50-60Hz 1.5A
Output Power	48Vdc / 0.8A 38.4W Max
Power Line	1.6m power cable with 1 core attached on adapter

PoE	
Brand	EnGenius
Model	EPE-48GR
Rating	48Vdc, 0.38A 18.24W

3. The following antenna was provided to the EUT.

Type	Gain(dBi)	Connector
Printed	Ant. 1: 4.2dBi	IPEX
	Ant. 2: 5.5dBi	

4. The above EUT information is declared by manufacturer and for more detailed features description, please refer to the manufacturer's specifications or user's manual.

### 3.2 Description of Test Modes

11 channels are provided for 802.11b, 802.11g and 802.11n (HT20):

Channel	Frequency	Channel	Frequency
1	2412MHz	7	2442MHz
2	2417MHz	8	2447MHz
3	2422MHz	9	2452MHz
4	2427MHz	10	2457MHz
5	2432MHz	11	2462MHz
6	2437MHz		

7 channels are provided for 802.11n (HT40):

Channel	Frequency	Channel	Frequency
3	2422MHz	7	2442MHz
4	2427MHz	8	2447MHz
5	2432MHz	9	2452MHz
6	2437MHz		



### 3.2.1 Test Mode Applicability and Tested Channel Detail

EUT CONFIGURE MODE	APPLICABLE TO				DESCRIPTION
	RE $\geq$ 1G	RE $<$ 1G	PLC	APCM	
A	√	√	√	√	Power from adapter
B	-	√	√	-	Power from PoE

Where **RE $\geq$ 1G**: Radiated Emission above 1GHz & Bandedge Measurement      **RE $<$ 1G**: Radiated Emission below 1GHz  
**PLC**: Power Line Conducted Emission      **APCM**: Antenna Port Conducted Measurement

**NOTE:** 1. The EUT had been pre-tested on the positioned of each 3 axis. The worst case was found when positioned on **Z-plane**.  
2. "-" means no effect.

#### Radiated Emission Test (Above 1GHz):

- Pre-Scan has been conducted to determine the worst-case mode from all possible combinations between available modulations, data rates and antenna ports (if EUT with antenna diversity architecture).
- Following channel(s) was (were) selected for the final test as listed below.

EUT CONFIGURE MODE	MODE	AVAILABLE CHANNEL	TESTED CHANNEL	MODULATION TECHNOLOGY	MODULATION TYPE	DATA RATE (Mbps)
A	802.11b	1 to 11	1, 6, 11	DSSS	DBPSK	1.0
A	802.11g	1 to 11	1, 6, 11	OFDM	BPSK	6.0
A	802.11n (HT20)	1 to 11	1, 6, 11	OFDM	BPSK	6.5
A	802.11n (HT40)	3 to 9	3, 6, 9	OFDM	BPSK	13.5

#### Radiated Emission Test (Below 1GHz):

- Pre-Scan has been conducted to determine the worst-case mode from all possible combinations between available modulations, data rates and antenna ports (if EUT with antenna diversity architecture).
- Following channel(s) was (were) selected for the final test as listed below.

EUT CONFIGURE MODE	MODE	AVAILABLE CHANNEL	TESTED CHANNEL	MODULATION TECHNOLOGY	MODULATION TYPE	DATA RATE (Mbps)
A, B	802.11n (HT20)	1 to 11	6	OFDM	BPSK	6.5

#### Power Line Conducted Emission Test:

- Pre-Scan has been conducted to determine the worst-case mode from all possible combinations between available modulations, data rates and antenna ports (if EUT with antenna diversity architecture).
- Following channel(s) was (were) selected for the final test as listed below.

EUT CONFIGURE MODE	MODE	AVAILABLE CHANNEL	TESTED CHANNEL	MODULATION TECHNOLOGY	MODULATION TYPE	DATA RATE (Mbps)
A, B	802.11n (HT20)	1 to 11	6	OFDM	BPSK	6.5

**Antenna Port Conducted Measurement:**

- This item includes all test value of each mode, but only includes spectrum plot of worst value of each mode.
- Pre-Scan has been conducted to determine the worst-case mode from all possible combinations between available modulations, data rates and antenna ports (if EUT with antenna diversity architecture).
- Following channel(s) was (were) selected for the final test as listed below.

EUT CONFIGURE MODE	MODE	AVAILABLE CHANNEL	TESTED CHANNEL	MODULATION TECHNOLOGY	MODULATION TYPE	DATA RATE (Mbps)
A	802.11b	1 to 11	1, 6, 11	DSSS	DBPSK	1.0
A	802.11g	1 to 11	1, 6, 11	OFDM	BPSK	6.0
A	802.11n (HT20)	1 to 11	1, 6, 11	OFDM	BPSK	6.5
A	802.11n (HT40)	3 to 9	3, 6, 9	OFDM	BPSK	13.5

**Test Condition:**

APPLICABLE TO	ENVIRONMENTAL CONDITIONS	INPUT POWER	TESTED BY
RE≥1G	21deg. C, 67%RH	120Vac, 60Hz	Jones Chang
RE<1G	22deg. C, 69%RH	120Vac, 60Hz 48Vdc	Jones Chang
PLC	17deg. C, 70%RH	120Vac, 60Hz 48Vdc	Nick Hus
APCM	25deg. C, 60%RH	120Vac, 60Hz	Anotnoy Lee

### 3.3 Duty Cycle of Test Signal

**802.11b, 802.11g:** Duty cycle of test signal is  $\geq 98\%$ , duty factor is not required.

Duty cycle of test signal is  $< 98\%$ , duty factor shall be considered.

**802.11n (HT20):** Duty cycle =  $1.267/1.32 = 0.96$ , Duty factor =  $10 * \log(1/0.96) = 0.18$

**802.11n (HT40):** Duty cycle =  $0.628/0.678 = 0.926$ , Duty factor =  $10 * \log(1/0.926) = 0.33$

**802.11b** **802.11g**

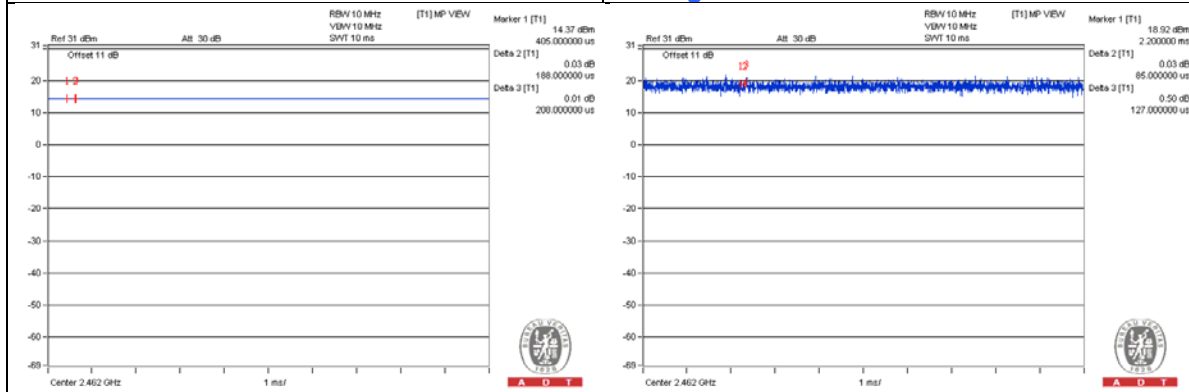

**802.11n (HT20)** **802.11n (HT40)**

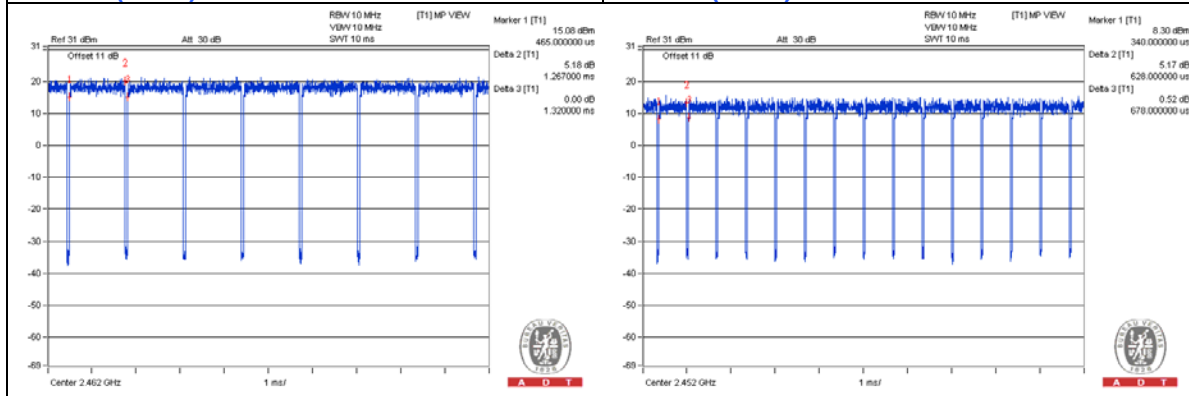

### 3.4 Description of Support Units

The EUT has been tested as an independent unit together with other necessary accessories or support units. The following support units or accessories were used to form a representative test configuration during the tests.

ID	Product	Brand	Model No.	Serial No.	FCC ID	Remarks
A.	Load	NA	NA	NA	NA	-
B.	Notebook	DELL	E5410	1HC2XM1	FCC DoC Approved	-
C.	Adapter	Powertron Electronics Corp.	PA1040-480IB080	-	-	Provided by client
D.	PoE	EnGenius	EPE-48GR	-	-	Provided by client

Note:

1. All power cords of the above support units are non-shielded (1.8m).
2. Items B~D acted as communication partners to transfer data.

ID	Descriptions	Qty.	Length (m)	Shielding (Yes/No)	Cores (Qty.)	Remarks
1.	LAN cable	1	5	N	0	-
2.	DC cable	1	1.6	N	1	Provided by client
3.	LAN cable	6	1.8	N	0	-
4.	LAN cable	1	1.8	N	0	-

Note: The core(s) is(are) originally attached to the cable(s).

#### 3.4.1 Configuration of System under Test

Test Mode A

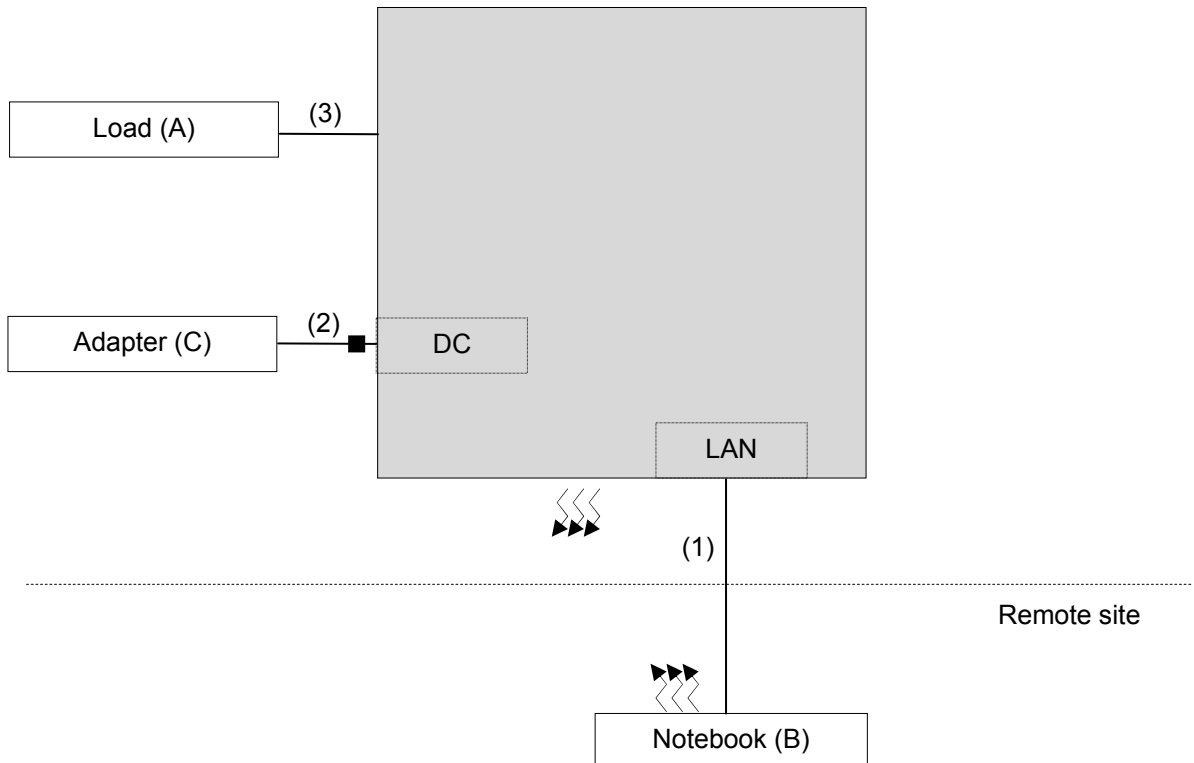

Test Mode B

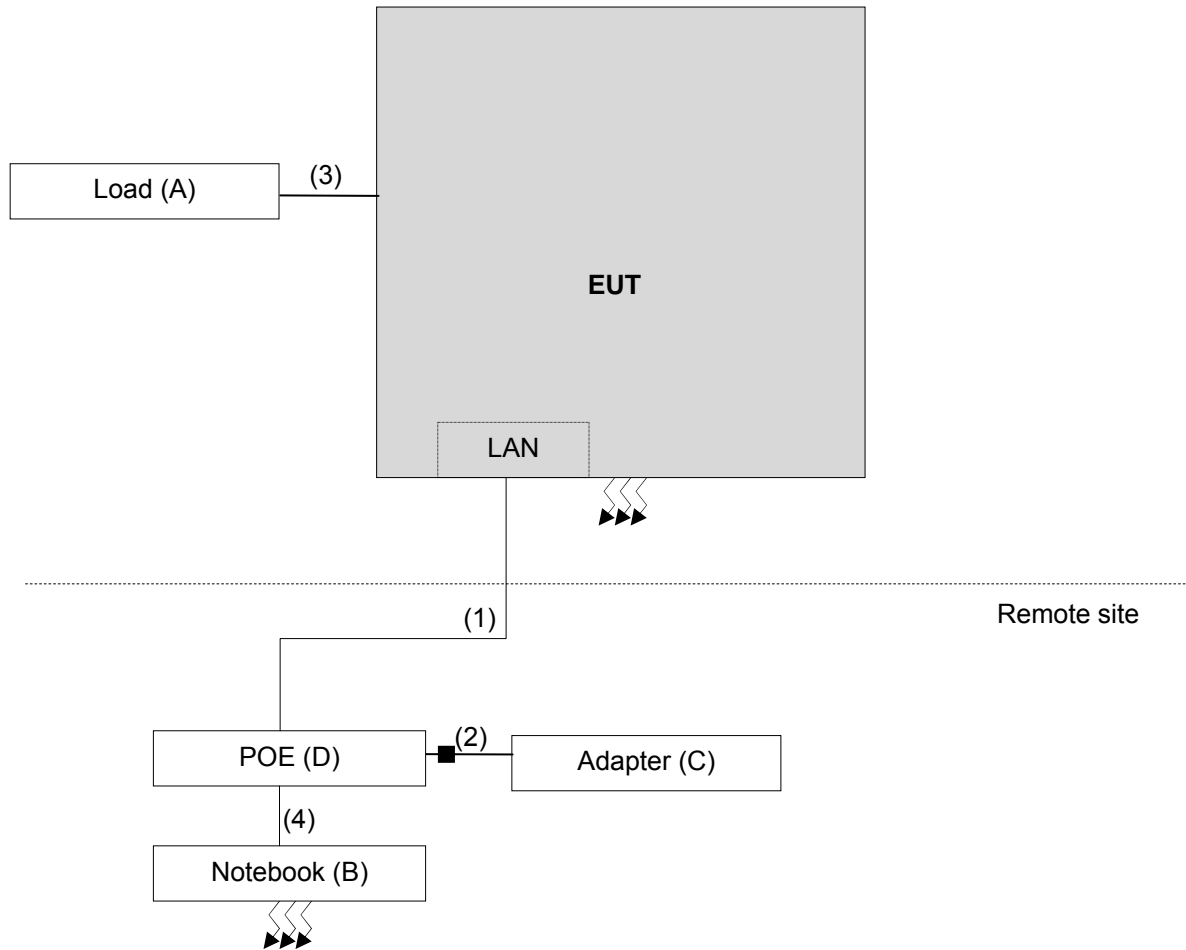

### 3.5 General Description of Applied Standards

The EUT is a RF Product. According to the specifications of the manufacturer, it must comply with the requirements of the following standards:

- FCC Part 15, Subpart C (15.247)**
- 558074 D01 DTS Meas Guidance v03r03**
- 662911 D01 Multiple Transmitter Output v02r01**
- ANSI C63.10-2013

All test items have been performed and recorded as per the above standards.

**NOTE:** The EUT has been verified to comply with the requirements of FCC Part 15, Subpart B, Class B (DoC). The test report has been issued separately.

## 4 Test Types and Results

### 4.1 Radiated Emission and Bandedge Measurement

#### 4.1.1 Limits of Radiated Emission and Bandedge Measurement

Radiated emissions which fall in the restricted bands must comply with the radiated emission limits specified as below table. Other emissions shall be at least 20dB below the highest level of the desired power:

Frequencies (MHz)	Field Strength (microvolts/meter)	Measurement Distance (meters)
0.009 ~ 0.490	2400/F(kHz)	300
0.490 ~ 1.705	24000/F(kHz)	30
1.705 ~ 30.0	30	30
30 ~ 88	100	3
88 ~ 216	150	3
216 ~ 960	200	3
Above 960	500	3

**NOTE:**

1. The lower limit shall apply at the transition frequencies.
2. Emission level (dBuV/m) = 20 log Emission level (uV/m).
3. For frequencies above 1000MHz, the field strength limits are based on average detector, however, the peak field strength of any emission shall not exceed the maximum permitted average limits, specified above by more than 20dB under any condition of modulation.



A D T

## 4.1.2 Test Instruments

DESCRIPTION & MANUFACTURER	MODEL NO.	SERIAL NO.	DATE OF CALIBRATION	DUE DATE OF CALIBRATION
Test Receiver ROHDE & SCHWARZ	ESIB7	100187	Apr. 10, 2015	Apr. 09, 2016
Spectrum Analyzer ROHDE & SCHWARZ	FSP40	100041	Sep. 02, 2015	Sep. 01, 2016
BILOG Antenna SCHWARZBECK	VULB9168	9168-160	Feb. 05, 2015	Feb. 04, 2016
HORN Antenna SCHWARZBECK	9120D	209	Feb. 09, 2015	Feb. 08, 2016
HORN Antenna SCHWARZBECK	BBHA 9170	BBHA9170241	Feb. 09, 2015	Feb. 08, 2016
Preamplifier Agilent	8447D	2944A10738	Oct.18, 2014	Oct. 17, 2015
Preamplifier Agilent	8449B	3008A01964	Aug. 22, 2015	Aug. 21, 2016
RF signal cable HUBER+SUHNER	SUCOFLEX 104	Cable-CH3-03(214 378)	Aug. 22, 2015	Aug. 21, 2016
RF signal cable HUBER+SUHNER	SUCOFLEX 106	Cable-CH3-03(309 224+12738)	Aug. 22, 2015	Aug. 21, 2016
Software BV ADT	ADT_Radiated_ V7.6.15.9.4	NA	NA	NA
Antenna Tower inn-co GmbH	MA 4000	013303	NA	NA
Antenna Tower Controller BV ADT	AT100	AT93021702	NA	NA
Turn Table BV ADT	TT100	TT93021702	NA	NA
Turn Table Controller BV ADT	SC100	SC93021702	NA	NA
High Speed Peak Power Meter	ML2495A	0824011	Jul. 09, 2015	Jul. 08, 2016
Power Sensor	MA2411B	0738171	Jul. 09, 2015	Jul. 08, 2016

- NOTE:**
1. The calibration interval of the above test instruments is 12 months and the calibrations are traceable to NML/ROC and NIST/USA.
  2. The test was performed in HwaYa Chamber 3.
  3. The horn antenna and HP preamplifier (model: 8449B) are used only for the measurement of emission frequency above 1GHz if tested.
  4. The FCC Site Registration No. is 988962.
  5. The IC Site Registration No. is IC 7450F-3.

#### 4.1.3 Test Procedures

- a. The EUT was placed on the top of a rotating table 0.8 meters (for below 1GHz) / 1.5 meters (for above 1GHz) above the ground at 3 meter chamber room for test. The table was rotated 360 degrees to determine the position of the highest radiation.
- b. The EUT was set 3 meters away from the interference-receiving antenna, which was mounted on the top of a variable-height antenna tower.
- c. The height of antenna is varied from one meter to four meters above the ground to determine the maximum value of the field strength. Both horizontal and vertical polarizations of the antenna are set to make the measurement.
- d. For each suspected emission, the EUT was arranged to its worst case and then the antenna was tuned to heights from 1 meter to 4 meters and the rotatable table was turned from 0 degrees to 360 degrees to find the maximum reading.
- e. The test-receiver system was set to quasi-peak detect function and specified bandwidth with maximum hold mode when the test frequency is below 1 GHz.
- f. The test-receiver system was set to peak and average detect function and specified bandwidth with maximum hold mode when the test frequency is above 1 GHz. If the peak reading value also meets average limit, measurement with the average detector is unnecessary.

**Note:**

1. The resolution bandwidth and video bandwidth of test receiver/spectrum analyzer is 120kHz for Quasi-peak detection (QP) at frequency below 1GHz.
2. The resolution bandwidth of test receiver/spectrum analyzer is 1 MHz and the video bandwidth is 3 MHz for Peak detection (PK) at frequency above 1GHz.
3. The resolution bandwidth of test receiver/spectrum analyzer is 1MHz and the video bandwidth is 3MHz for RMS Average (Duty cycle < 98%) for Average detection (AV) at frequency above 1GHz, then the measurement results was added to a correction factor ( $10 \log(1/\text{duty cycle})$ ).
4. The resolution bandwidth of test receiver/spectrum analyzer is 1MHz and the video bandwidth is 10Hz (Duty cycle  $\geq 98\%$ ) for Average detection (AV) at frequency above 1GHz.
5. All modes of operation were investigated and the worst-case emissions are reported.

#### 4.1.4 Deviation from Test Standard

No deviation.



4.1.5 Test Set Up

**<Frequency Range below 1GHz>**

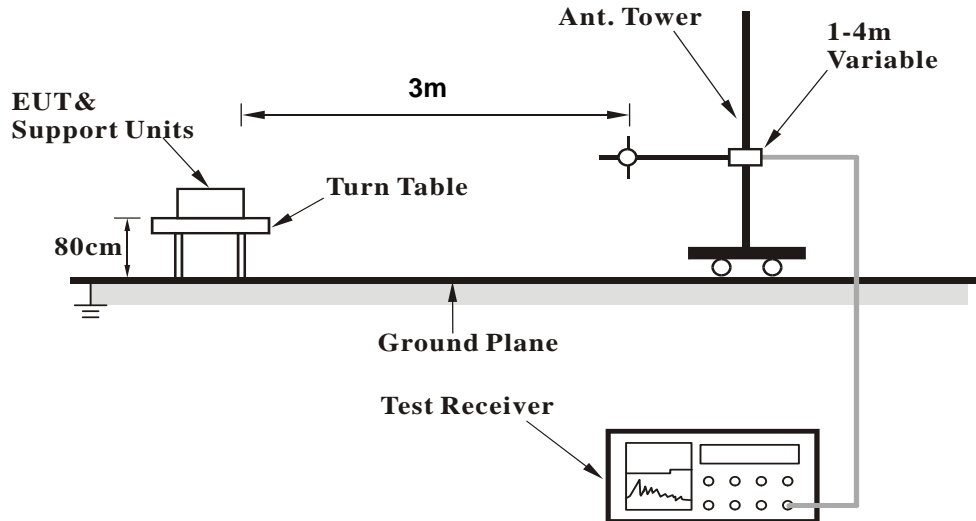

**<Frequency Range above 1GHz>**

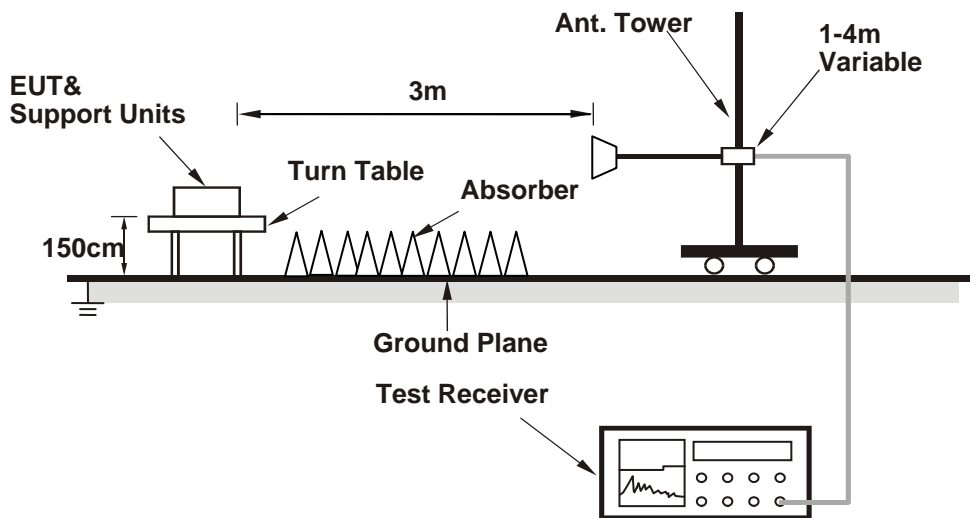

For the actual test configuration, please refer to the attached file (Test Setup Photo).

#### 4.1.6 EUT Operating Conditions

- a. Placed the EUT on the testing table.
- b. Prepared notebook to act as a communication partner and placed it outside of testing area.
- c. The communication partner connected with EUT via a RJ45 cable and ran a test program (provided by manufacturer) to enable EUT under transmission condition continuously at specific channel frequency.
- d. The communication partner sent data to EUT by command "PING".
- e. The necessary accessories enable the system in full functions.

#### 4.1.7 Test Results

#### Above 1GHz Data :

#### 802.11b

<b>CHANNEL</b>	TX Channel 1	<b>DETECTOR FUNCTION</b>	Peak (PK)
<b>FREQUENCY RANGE</b>	1GHz ~ 25GHz		Average (AV)

#### ANTENNA POLARITY & TEST DISTANCE: HORIZONTAL AT 3 M

NO.	FREQ. (MHz)	EMISSION LEVEL (dBuV/m)	LIMIT (dBuV/m)	MARGIN (dB)	ANTENNA HEIGHT (m)	TABLE ANGLE (Degree)	RAW VALUE (dBuV)	CORRECTION FACTOR (dB/m)
1	2390.00	57.4 PK	74.0	-16.6	1.18 H	305	24.90	32.50
2	2390.00	45.8 AV	54.0	-8.2	1.18 H	305	13.30	32.50
3	*2412.00	101.1 PK			1.18 H	305	68.50	32.60
4	*2412.00	97.6 AV			1.18 H	305	65.00	32.60
5	4824.00	56.1 PK	74.0	-17.9	1.82 H	333	50.00	6.10
6	4824.00	52.6 AV	54.0	-1.4	1.82 H	333	46.50	6.10

#### ANTENNA POLARITY & TEST DISTANCE: VERTICAL AT 3 M

NO.	FREQ. (MHz)	EMISSION LEVEL (dBuV/m)	LIMIT (dBuV/m)	MARGIN (dB)	ANTENNA HEIGHT (m)	TABLE ANGLE (Degree)	RAW VALUE (dBuV)	CORRECTION FACTOR (dB/m)
1	2390.00	57.3 PK	74.0	-16.7	1.49 V	333	24.80	32.50
2	2390.00	46.6 AV	54.0	-7.4	1.49 V	333	14.10	32.50
3	*2412.00	103.9 PK			1.49 V	333	71.30	32.60
4	*2412.00	100.2 AV			1.49 V	333	67.60	32.60
5	4824.00	55.0 PK	74.0	-19.0	1.72 V	336	48.90	6.10
6	4824.00	50.9 AV	54.0	-3.1	1.72 V	336	44.80	6.10

#### REMARKS:

1. Emission Level(dBuV/m) = Raw Value(dBuV) + Correction Factor(dB/m)
2. Correction Factor(dB/m) = Antenna Factor(dB/m) + Cable Factor(dB)
3. The other emission levels were very low against the limit.
4. Margin value = Emission Level – Limit value
5. " \* ": Fundamental frequency.

<b>CHANNEL</b>	TX Channel 6	<b>DETECTOR FUNCTION</b>	Peak (PK)
<b>FREQUENCY RANGE</b>	1GHz ~ 25GHz		Average (AV)

**ANTENNA POLARITY & TEST DISTANCE: HORIZONTAL AT 3 M**

NO.	FREQ. (MHz)	EMISSION LEVEL (dBuV/m)	LIMIT (dBuV/m)	MARGIN (dB)	ANTENNA HEIGHT (m)	TABLE ANGLE (Degree)	RAW VALUE (dBuV)	CORRECTION FACTOR (dB/m)
1	*2437.00	100.6 PK			1.15 H	354	67.90	32.70
2	*2437.00	97.2 AV			1.15 H	354	64.50	32.70
3	4874.00	55.3 PK	74.0	-18.7	1.83 H	345	49.10	6.20
4	4874.00	52.7 AV	54.0	-1.3	1.83 H	345	46.50	6.20

**ANTENNA POLARITY & TEST DISTANCE: VERTICAL AT 3 M**

NO.	FREQ. (MHz)	EMISSION LEVEL (dBuV/m)	LIMIT (dBuV/m)	MARGIN (dB)	ANTENNA HEIGHT (m)	TABLE ANGLE (Degree)	RAW VALUE (dBuV)	CORRECTION FACTOR (dB/m)
1	*2437.00	105.3 PK			1.40 V	347	72.60	32.70
2	*2437.00	101.6 AV			1.40 V	347	68.90	32.70
3	4874.00	52.5 PK	74.0	-21.5	1.63 V	5	46.30	6.20
4	4874.00	47.2 AV	54.0	-6.8	1.63 V	5	41.00	6.20

**REMARKS:**

1. Emission Level(dBuV/m) = Raw Value(dBuV) + Correction Factor(dB/m)
2. Correction Factor(dB/m) = Antenna Factor(dB/m) + Cable Factor(dB)
3. The other emission levels were very low against the limit.
4. Margin value = Emission Level – Limit value
5. " \* ": Fundamental frequency.

<b>CHANNEL</b>	TX Channel 11	<b>DETECTOR FUNCTION</b>	Peak (PK)
<b>FREQUENCY RANGE</b>	1GHz ~ 25GHz		Average (AV)

**ANTENNA POLARITY & TEST DISTANCE: HORIZONTAL AT 3 M**

NO.	FREQ. (MHz)	EMISSION LEVEL (dBuV/m)	LIMIT (dBuV/m)	MARGIN (dB)	ANTENNA HEIGHT (m)	TABLE ANGLE (Degree)	RAW VALUE (dBuV)	CORRECTION FACTOR (dB/m)
1	*2462.00	102.5 PK			1.15 H	315	69.90	32.60
2	*2462.00	99.0 AV			1.15 H	315	66.40	32.60
3	2483.50	57.1 PK	74.0	-16.9	1.15 H	315	24.40	32.70
4	2483.50	45.6 AV	54.0	-8.4	1.15 H	315	12.90	32.70
5	4924.00	54.4 PK	74.0	-19.6	1.71 H	343	48.10	6.30
<b>6</b>	<b>4924.00</b>	<b>53.0 AV</b>	<b>54.0</b>	<b>-1.0</b>	<b>1.71 H</b>	<b>343</b>	<b>46.70</b>	<b>6.30</b>

**ANTENNA POLARITY & TEST DISTANCE: VERTICAL AT 3 M**

NO.	FREQ. (MHz)	EMISSION LEVEL (dBuV/m)	LIMIT (dBuV/m)	MARGIN (dB)	ANTENNA HEIGHT (m)	TABLE ANGLE (Degree)	RAW VALUE (dBuV)	CORRECTION FACTOR (dB/m)
1	*2462.00	103.1 PK			1.42 V	334	70.50	32.60
2	*2462.00	99.5 AV			1.42 V	334	66.90	32.60
3	2483.50	56.7 PK	74.0	-17.3	1.44 V	339	24.00	32.70
4	2483.50	44.9 AV	54.0	-9.1	1.44 V	339	12.20	32.70
5	4924.00	52.0 PK	74.0	-22.0	1.69 V	310	45.70	6.30
6	4924.00	44.2 AV	54.0	-9.8	1.69 V	310	37.90	6.30

**REMARKS:**

1. Emission Level(dBuV/m) = Raw Value(dBuV) + Correction Factor(dB/m)
2. Correction Factor(dB/m) = Antenna Factor(dB/m) + Cable Factor(dB)
3. The other emission levels were very low against the limit.
4. Margin value = Emission Level – Limit value
5. " \* ": Fundamental frequency.

802.11g

<b>CHANNEL</b>	TX Channel 1	<b>DETECTOR FUNCTION</b>	Peak (PK)
<b>FREQUENCY RANGE</b>	1GHz ~ 25GHz		Average (AV)

**ANTENNA POLARITY & TEST DISTANCE: HORIZONTAL AT 3 M**

NO.	FREQ. (MHz)	EMISSION LEVEL (dBuV/m)	LIMIT (dBuV/m)	MARGIN (dB)	ANTENNA HEIGHT (m)	TABLE ANGLE (Degree)	RAW VALUE (dBuV)	CORRECTION FACTOR (dB/m)
1	2390.00	66.5 PK	74.0	-7.5	1.04 H	300	34.00	32.50
2	2390.00	51.6 AV	54.0	-2.4	1.04 H	300	19.10	32.50
3	*2412.00	105.1 PK			1.18 H	305	72.50	32.60
4	*2412.00	95.5 AV			1.18 H	305	62.90	32.60
5	4824.00	55.0 PK	74.0	-19.0	1.45 H	336	48.90	6.10
6	4824.00	41.1 AV	54.0	-12.9	1.45 H	336	35.00	6.10

**ANTENNA POLARITY & TEST DISTANCE: VERTICAL AT 3 M**

NO.	FREQ. (MHz)	EMISSION LEVEL (dBuV/m)	LIMIT (dBuV/m)	MARGIN (dB)	ANTENNA HEIGHT (m)	TABLE ANGLE (Degree)	RAW VALUE (dBuV)	CORRECTION FACTOR (dB/m)
1	2390.00	68.1 PK	74.0	-5.9	1.27 V	19	35.60	32.50
2	2390.00	53.0 AV	54.0	-1.0	1.27 V	19	20.50	32.50
3	*2412.00	108.8 PK			1.43 V	347	76.20	32.60
4	*2412.00	100.0 AV			1.43 V	347	67.40	32.60
5	4824.00	50.1 PK	74.0	-23.9	1.49 V	255	44.00	6.10
6	4824.00	37.9 AV	54.0	-16.1	1.49 V	255	31.80	6.10

**REMARKS:**

1. Emission Level(dBuV/m) = Raw Value(dBuV) + Correction Factor(dB/m)
2. Correction Factor(dB/m) = Antenna Factor(dB/m) + Cable Factor(dB)
3. The other emission levels were very low against the limit.
4. Margin value = Emission Level – Limit value
5. " \* ": Fundamental frequency.

<b>CHANNEL</b>	TX Channel 6	<b>DETECTOR FUNCTION</b>	Peak (PK)
<b>FREQUENCY RANGE</b>	1GHz ~ 25GHz		Average (AV)

**ANTENNA POLARITY & TEST DISTANCE: HORIZONTAL AT 3 M**

NO.	FREQ. (MHz)	EMISSION LEVEL (dBuV/m)	LIMIT (dBuV/m)	MARGIN (dB)	ANTENNA HEIGHT (m)	TABLE ANGLE (Degree)	RAW VALUE (dBuV)	CORRECTION FACTOR (dB/m)
1	2390.00	63.7 PK	74.0	-10.3	1.18 H	307	31.20	32.50
2	2390.00	49.6 AV	54.0	-4.4	1.18 H	307	17.10	32.50
3	*2437.00	111.4 PK			1.04 H	314	78.70	32.70
4	*2437.00	102.1 AV			1.04 H	314	69.40	32.70
5	2483.50	68.1 PK	74.0	-5.9	1.15 H	310	35.40	32.70
6	2483.50	51.4 AV	54.0	-2.6	1.15 H	310	18.70	32.70
7	4874.00	66.6 PK	74.0	-7.4	1.59 H	342	60.40	6.20
8	4874.00	51.8 AV	54.0	-2.2	1.59 H	342	45.60	6.20

**ANTENNA POLARITY & TEST DISTANCE: VERTICAL AT 3 M**

NO.	FREQ. (MHz)	EMISSION LEVEL (dBuV/m)	LIMIT (dBuV/m)	MARGIN (dB)	ANTENNA HEIGHT (m)	TABLE ANGLE (Degree)	RAW VALUE (dBuV)	CORRECTION FACTOR (dB/m)
1	2390.00	67.1 PK	74.0	-6.9	1.29 V	357	34.60	32.50
2	2390.00	52.1 AV	54.0	-1.9	1.29 V	357	19.60	32.50
3	*2437.00	114.1 PK			1.42 V	340	81.40	32.70
4	*2437.00	104.4 AV			1.42 V	340	71.70	32.70
5	2483.50	68.0 PK	74.0	-6.0	1.27 V	332	35.30	32.70
6	2483.50	51.7 AV	54.0	-2.3	1.27 V	332	19.00	32.70
7	4874.00	59.1 PK	74.0	-14.9	1.46 V	330	52.90	6.20
8	4874.00	45.7 AV	54.0	-8.3	1.46 V	330	39.50	6.20

**REMARKS:**

1. Emission Level(dBuV/m) = Raw Value(dBuV) + Correction Factor(dB/m)
2. Correction Factor(dB/m) = Antenna Factor(dB/m) + Cable Factor(dB)
3. The other emission levels were very low against the limit.
4. Margin value = Emission Level – Limit value
5. " \* ": Fundamental frequency.

<b>CHANNEL</b>	TX Channel 11	<b>DETECTOR FUNCTION</b>	Peak (PK)
<b>FREQUENCY RANGE</b>	1GHz ~ 25GHz		Average (AV)

**ANTENNA POLARITY & TEST DISTANCE: HORIZONTAL AT 3 M**

NO.	FREQ. (MHz)	EMISSION LEVEL (dBuV/m)	LIMIT (dBuV/m)	MARGIN (dB)	ANTENNA HEIGHT (m)	TABLE ANGLE (Degree)	RAW VALUE (dBuV)	CORRECTION FACTOR (dB/m)
1	*2462.00	106.3 PK			1.15 H	298	73.70	32.60
2	*2462.00	97.1 AV			1.15 H	298	64.50	32.60
3	2483.50	72.0 PK	74.0	-2.0	1.14 H	319	39.30	32.70
4	2483.50	52.2 AV	54.0	-1.8	1.14 H	319	19.50	32.70
5	4924.00	56.9 PK	74.0	-17.1	1.46 H	341	50.60	6.30
6	4924.00	43.2 AV	54.0	-10.8	1.46 H	341	36.90	6.30

**ANTENNA POLARITY & TEST DISTANCE: VERTICAL AT 3 M**

NO.	FREQ. (MHz)	EMISSION LEVEL (dBuV/m)	LIMIT (dBuV/m)	MARGIN (dB)	ANTENNA HEIGHT (m)	TABLE ANGLE (Degree)	RAW VALUE (dBuV)	CORRECTION FACTOR (dB/m)
1	*2462.00	107.9 PK			1.54 V	154	75.30	32.60
2	*2462.00	99.3 AV			1.54 V	154	66.70	32.60
3	2483.50	72.4 PK	74.0	-1.6	1.28 V	336	39.70	32.70
4	2483.50	52.0 AV	54.0	-2.0	1.28 V	336	19.30	32.70
5	4924.00	51.3 PK	74.0	-22.7	4.00 V	329	45.00	6.30
6	4924.00	38.0 AV	54.0	-16.0	4.00 V	329	31.70	6.30

**REMARKS:**

1. Emission Level(dBuV/m) = Raw Value(dBuV) + Correction Factor(dB/m)
2. Correction Factor(dB/m) = Antenna Factor(dB/m) + Cable Factor(dB)
3. The other emission levels were very low against the limit.
4. Margin value = Emission Level – Limit value
5. " \* ": Fundamental frequency.



802.11n (20MHz)

<b>CHANNEL</b>	TX Channel 1	<b>DETECTOR FUNCTION</b>	Peak (PK)
<b>FREQUENCY RANGE</b>	1GHz ~ 25GHz		Average (AV)

**ANTENNA POLARITY & TEST DISTANCE: HORIZONTAL AT 3 M**

NO.	FREQ. (MHz)	EMISSION LEVEL (dBuV/m)	LIMIT (dBuV/m)	MARGIN (dB)	ANTENNA HEIGHT (m)	TABLE ANGLE (Degree)	RAW VALUE (dBuV)	CORRECTION FACTOR (dB/m)
1	2390.00	66.4 PK	74.0	-7.6	1.03 H	320	33.90	32.50
2	2390.00	49.4 AV	54.0	-4.6	1.03 H	320	16.90	32.50
3	*2412.00	101.7 PK			1.05 H	318	69.10	32.60
4	*2412.00	92.9 AV			1.05 H	318	60.30	32.60
5	4824.00	52.4 PK	74.0	-21.6	1.66 H	339	46.30	6.10
6	4824.00	38.7 AV	54.0	-15.3	1.66 H	339	32.60	6.10

**ANTENNA POLARITY & TEST DISTANCE: VERTICAL AT 3 M**

NO.	FREQ. (MHz)	EMISSION LEVEL (dBuV/m)	LIMIT (dBuV/m)	MARGIN (dB)	ANTENNA HEIGHT (m)	TABLE ANGLE (Degree)	RAW VALUE (dBuV)	CORRECTION FACTOR (dB/m)
1	2390.00	72.9 PK	74.0	-1.1	1.26 V	345	40.40	32.50
2	2390.00	51.7 AV	54.0	-2.3	1.26 V	345	19.20	32.50
3	*2412.00	107.1 PK			1.45 V	348	74.50	32.60
4	*2412.00	97.7 AV			1.45 V	348	65.10	32.60
5	4824.00	50.8 PK	74.0	-23.2	1.48 V	328	44.70	6.10
6	4824.00	37.6 AV	54.0	-16.4	1.48 V	328	31.50	6.10

**REMARKS:**

1. Emission Level(dBuV/m) = Raw Value(dBuV) + Correction Factor(dB/m)
2. Correction Factor(dB/m) = Antenna Factor(dB/m) + Cable Factor(dB)
3. The other emission levels were very low against the limit.
4. Margin value = Emission Level – Limit value
5. " \* ": Fundamental frequency.

<b>CHANNEL</b>	TX Channel 6	<b>DETECTOR FUNCTION</b>	Peak (PK)
<b>FREQUENCY RANGE</b>	1GHz ~ 25GHz		Average (AV)

**ANTENNA POLARITY & TEST DISTANCE: HORIZONTAL AT 3 M**

NO.	FREQ. (MHz)	EMISSION LEVEL (dBuV/m)	LIMIT (dBuV/m)	MARGIN (dB)	ANTENNA HEIGHT (m)	TABLE ANGLE (Degree)	RAW VALUE (dBuV)	CORRECTION FACTOR (dB/m)
1	2390.00	64.6 PK	74.0	-9.4	1.17 H	305	32.10	32.50
2	2390.00	49.8 AV	54.0	-4.2	1.17 H	305	17.30	32.50
3	*2437.00	110.6 PK			1.32 H	310	77.90	32.70
4	*2437.00	100.9 AV			1.32 H	310	68.20	32.70
5	2483.50	68.2 PK	74.0	-5.8	1.00 H	288	35.50	32.70
6	2483.50	50.7 AV	54.0	-3.3	1.00 H	288	18.00	32.70
7	4874.00	63.5 PK	74.0	-10.5	1.64 H	342	57.30	6.20
8	4874.00	50.0 AV	54.0	-4.0	1.64 H	342	43.80	6.20

**ANTENNA POLARITY & TEST DISTANCE: VERTICAL AT 3 M**

NO.	FREQ. (MHz)	EMISSION LEVEL (dBuV/m)	LIMIT (dBuV/m)	MARGIN (dB)	ANTENNA HEIGHT (m)	TABLE ANGLE (Degree)	RAW VALUE (dBuV)	CORRECTION FACTOR (dB/m)
1	2390.00	68.1 PK	74.0	-5.9	1.46 V	345	35.60	32.50
2	2390.00	52.7 AV	54.0	-1.3	1.46 V	345	20.20	32.50
3	*2437.00	116.0 PK			1.59 V	346	83.30	32.70
4	*2437.00	105.5 AV			1.59 V	346	72.80	32.70
5	2483.50	70.5 PK	74.0	-3.5	1.23 V	348	37.80	32.70
6	2483.50	52.4 AV	54.0	-1.6	1.23 V	348	19.70	32.70
7	4874.00	59.2 PK	74.0	-14.8	1.54 V	340	53.00	6.20
8	4874.00	44.7 AV	54.0	-9.3	1.54 V	340	38.50	6.20

**REMARKS:**

1. Emission Level(dBuV/m) = Raw Value(dBuV) + Correction Factor(dB/m)
2. Correction Factor(dB/m) = Antenna Factor(dB/m) + Cable Factor(dB)
3. The other emission levels were very low against the limit.
4. Margin value = Emission Level – Limit value
5. " \* ": Fundamental frequency.

<b>CHANNEL</b>	TX Channel 11	<b>DETECTOR FUNCTION</b>	Peak (PK)
<b>FREQUENCY RANGE</b>	1GHz ~ 25GHz		Average (AV)

**ANTENNA POLARITY & TEST DISTANCE: HORIZONTAL AT 3 M**

NO.	FREQ. (MHz)	EMISSION LEVEL (dBuV/m)	LIMIT (dBuV/m)	MARGIN (dB)	ANTENNA HEIGHT (m)	TABLE ANGLE (Degree)	RAW VALUE (dBuV)	CORRECTION FACTOR (dB/m)
1	*2462.00	104.9 PK			1.14 H	319	72.30	32.60
2	*2462.00	95.2 AV			1.14 H	319	62.60	32.60
3	2483.50	70.5 PK	74.0	-3.5	1.00 H	336	37.80	32.70
4	2483.50	52.0 AV	54.0	-2.0	1.00 H	336	19.30	32.70
5	4924.00	54.7 PK	74.0	-19.3	1.48 H	342	48.40	6.30
6	4924.00	40.9 AV	54.0	-13.1	1.48 H	342	34.60	6.30

**ANTENNA POLARITY & TEST DISTANCE: VERTICAL AT 3 M**

NO.	FREQ. (MHz)	EMISSION LEVEL (dBuV/m)	LIMIT (dBuV/m)	MARGIN (dB)	ANTENNA HEIGHT (m)	TABLE ANGLE (Degree)	RAW VALUE (dBuV)	CORRECTION FACTOR (dB/m)
1	*2462.00	107.8 PK			1.55 V	344	75.20	32.60
2	*2462.00	97.9 AV			1.55 V	344	65.30	32.60
<b>3</b>	<b>2483.50</b>	<b>73.0 PK</b>	<b>74.0</b>	<b>-1.0</b>	<b>1.31 V</b>	<b>336</b>	<b>40.30</b>	<b>32.70</b>
4	2483.50	51.9 AV	54.0	-2.1	1.31 V	336	19.20	32.70
5	4924.00	49.0 PK	74.0	-25.0	1.45 V	325	42.70	6.30
6	4924.00	36.2 AV	54.0	-17.8	1.45 V	325	29.90	6.30

**REMARKS:**

1. Emission Level(dBuV/m) = Raw Value(dBuV) + Correction Factor(dB/m)
2. Correction Factor(dB/m) = Antenna Factor(dB/m) + Cable Factor(dB)
3. The other emission levels were very low against the limit.
4. Margin value = Emission Level – Limit value
5. " \* ": Fundamental frequency.

802.11n (40MHz)

<b>CHANNEL</b>	TX Channel 3	<b>DETECTOR FUNCTION</b>	Peak (PK)
<b>FREQUENCY RANGE</b>	1GHz ~ 25GHz		Average (AV)

ANTENNA POLARITY & TEST DISTANCE: HORIZONTAL AT 3 M								
NO.	FREQ. (MHz)	EMISSION LEVEL (dBuV/m)	LIMIT (dBuV/m)	MARGIN (dB)	ANTENNA HEIGHT (m)	TABLE ANGLE (Degree)	RAW VALUE (dBuV)	CORRECTION FACTOR (dB/m)
1	2390.00	67.0 PK	74.0	-7.0	1.09 H	313	34.50	32.50
2	2390.00	48.8 AV	54.0	-5.2	1.09 H	313	16.30	32.50
3	*2422.00	97.9 PK			1.17 H	308	65.30	32.60
4	*2422.00	88.6 AV			1.17 H	308	56.00	32.60
5	4844.00	48.1 PK	74.0	-25.9	1.50 H	359	42.00	6.10
6	4844.00	34.9 AV	54.0	-19.1	1.50 H	359	28.80	6.10

ANTENNA POLARITY & TEST DISTANCE: VERTICAL AT 3 M								
NO.	FREQ. (MHz)	EMISSION LEVEL (dBuV/m)	LIMIT (dBuV/m)	MARGIN (dB)	ANTENNA HEIGHT (m)	TABLE ANGLE (Degree)	RAW VALUE (dBuV)	CORRECTION FACTOR (dB/m)
1	2390.00	67.0 PK	74.0	-7.0	1.09 H	313	34.50	32.50
2	2390.00	48.8 AV	54.0	-5.2	1.09 H	313	16.30	32.50
3	*2422.00	97.9 PK			1.17 H	308	65.30	32.60
4	*2422.00	88.6 AV			1.17 H	308	56.00	32.60
5	4844.00	48.1 PK	74.0	-25.9	1.50 H	359	42.00	6.10
6	4844.00	34.9 AV	54.0	-19.1	1.50 H	359	28.80	6.10

**REMARKS:**

1. Emission Level(dBuV/m) = Raw Value(dBuV) + Correction Factor(dB/m)
2. Correction Factor(dB/m) = Antenna Factor(dB/m) + Cable Factor(dB)
3. The other emission levels were very low against the limit.
4. Margin value = Emission Level – Limit value
5. " \* ": Fundamental frequency.

<b>CHANNEL</b>	TX Channel 6	<b>DETECTOR FUNCTION</b>	Peak (PK)
<b>FREQUENCY RANGE</b>	1GHz ~ 25GHz		Average (AV)

**ANTENNA POLARITY & TEST DISTANCE: HORIZONTAL AT 3 M**

NO.	FREQ. (MHz)	EMISSION LEVEL (dBuV/m)	LIMIT (dBuV/m)	MARGIN (dB)	ANTENNA HEIGHT (m)	TABLE ANGLE (Degree)	RAW VALUE (dBuV)	CORRECTION FACTOR (dB/m)
1	2390.00	63.2 PK	74.0	-10.8	1.10 H	300	30.70	32.50
2	2390.00	49.7 AV	54.0	-4.3	1.10 H	300	17.20	32.50
3	*2437.00	101.2 PK			1.15 H	303	68.50	32.70
4	*2437.00	91.6 AV			1.15 H	303	58.90	32.70
5	4874.00	48.4 PK	74.0	-25.6	1.45 H	58	42.20	6.20
6	4874.00	35.2 AV	54.0	-18.8	1.45 H	58	29.00	6.20

**ANTENNA POLARITY & TEST DISTANCE: VERTICAL AT 3 M**

NO.	FREQ. (MHz)	EMISSION LEVEL (dBuV/m)	LIMIT (dBuV/m)	MARGIN (dB)	ANTENNA HEIGHT (m)	TABLE ANGLE (Degree)	RAW VALUE (dBuV)	CORRECTION FACTOR (dB/m)
1	2390.00	68.7 PK	74.0	-5.3	1.26 V	343	36.20	32.50
2	2390.00	52.8 AV	54.0	-1.2	1.26 V	343	20.30	32.50
3	*2437.00	103.0 PK			1.44 V	6	70.30	32.70
4	*2437.00	93.5 AV			1.44 V	6	60.80	32.70
5	4874.00	48.8 PK	74.0	-25.2	1.29 V	286	42.60	6.20
6	4874.00	35.9 AV	54.0	-18.1	1.29 V	286	29.70	6.20

**REMARKS:**

1. Emission Level(dBuV/m) = Raw Value(dBuV) + Correction Factor(dB/m)
2. Correction Factor(dB/m) = Antenna Factor(dB/m) + Cable Factor(dB)
3. The other emission levels were very low against the limit.
4. Margin value = Emission Level – Limit value
5. " \* " : Fundamental frequency.

<b>CHANNEL</b>	TX Channel 9	<b>DETECTOR FUNCTION</b>	Peak (PK)
<b>FREQUENCY RANGE</b>	1GHz ~ 25GHz		Average (AV)

**ANTENNA POLARITY & TEST DISTANCE: HORIZONTAL AT 3 M**

NO.	FREQ. (MHz)	EMISSION LEVEL (dBuV/m)	LIMIT (dBuV/m)	MARGIN (dB)	ANTENNA HEIGHT (m)	TABLE ANGLE (Degree)	RAW VALUE (dBuV)	CORRECTION FACTOR (dB/m)
1	*2452.00	99.7 PK			1.14 H	309	67.00	32.70
2	*2452.00	89.7 AV			1.14 H	309	57.00	32.70
3	2483.50	71.9 PK	74.0	-2.1	1.27 H	326	39.20	32.70
4	2483.50	52.9 AV	54.0	-1.1	1.27 H	326	20.20	32.70
5	4904.00	48.0 PK	74.0	-26.0	1.24 H	277	41.90	6.10
6	4904.00	34.6 AV	54.0	-19.4	1.24 H	277	28.50	6.10

**ANTENNA POLARITY & TEST DISTANCE: VERTICAL AT 3 M**

NO.	FREQ. (MHz)	EMISSION LEVEL (dBuV/m)	LIMIT (dBuV/m)	MARGIN (dB)	ANTENNA HEIGHT (m)	TABLE ANGLE (Degree)	RAW VALUE (dBuV)	CORRECTION FACTOR (dB/m)
1	*2452.00	101.7 PK			1.58 V	354	69.00	32.70
2	*2452.00	91.7 AV			1.58 V	354	59.00	32.70
3	2483.50	72.1 PK	74.0	-1.9	1.31 V	326	39.40	32.70
4	2483.50	51.9 AV	54.0	-2.1	1.31 V	326	19.20	32.70
5	4904.00	48.2 PK	74.0	-25.8	1.40 V	293	42.10	6.10
6	4904.00	35.3 AV	54.0	-18.7	1.40 V	293	29.20	6.10

**REMARKS:**

1. Emission Level(dBuV/m) = Raw Value(dBuV) + Correction Factor(dB/m)
2. Correction Factor(dB/m) = Antenna Factor(dB/m) + Cable Factor(dB)
3. The other emission levels were very low against the limit.
4. Margin value = Emission Level – Limit value
5. " \* ": Fundamental frequency.

**Below 1GHz Data:**
**802.11n (HT20)**

<b>CHANNEL</b>	TX Channel 6	<b>DETECTOR FUNCTION</b>	Quasi-Peak (QP)
<b>FREQUENCY RANGE</b>	30MHz ~ 1GHz	<b>TEST MODE</b>	A

**ANTENNA POLARITY & TEST DISTANCE: HORIZONTAL AT 3 M**

NO.	FREQ. (MHz)	EMISSION LEVEL (dBuV/m)	LIMIT (dBuV/m)	MARGIN (dB)	ANTENNA HEIGHT (m)	TABLE ANGLE (Degree)	RAW VALUE (dBuV)	CORRECTION FACTOR (dB/m)
1	57.12	30.7 QP	40.0	-9.3	2.00 H	15	45.50	-14.80
2	148.50	28.7 QP	43.5	-14.8	1.01 H	106	42.70	-14.00
3	204.89	29.9 QP	43.5	-13.6	1.01 H	256	46.70	-16.80
4	374.04	38.4 QP	46.0	-7.6	1.01 H	226	49.40	-11.00
5	624.85	32.2 QP	46.0	-13.8	1.50 H	325	37.60	-5.40
6	875.67	39.2 QP	46.0	-6.8	1.50 H	10	40.10	-0.90

**ANTENNA POLARITY & TEST DISTANCE: VERTICAL AT 3 M**

NO.	FREQ. (MHz)	EMISSION LEVEL (dBuV/m)	LIMIT (dBuV/m)	MARGIN (dB)	ANTENNA HEIGHT (m)	TABLE ANGLE (Degree)	RAW VALUE (dBuV)	CORRECTION FACTOR (dB/m)
1	47.40	38.2 QP	40.0	-1.8	1.00 V	325	52.80	-14.60
2	62.95	36.4 QP	40.0	-3.6	1.00 V	194	51.80	-15.40
3	111.56	30.6 QP	43.5	-12.9	1.00 V	162	47.90	-17.30
4	374.04	34.1 QP	46.0	-11.9	1.49 V	66	45.10	-11.00
5	624.85	30.7 QP	46.0	-15.3	1.49 V	160	36.10	-5.40
6	875.67	36.4 QP	46.0	-9.6	1.49 V	162	37.30	-0.90

**REMARKS:**

1. Emission Level(dBuV/m) = Raw Value(dBuV) + Correction Factor(dB/m)
2. Correction Factor(dB/m) = Antenna Factor(dB/m) + Cable Factor(dB)
3. The other emission levels were very low against the limit.
4. Margin value = Emission Level – Limit value

<b>CHANNEL</b>	TX Channel 6	<b>DETECTOR FUNCTION</b>	Quasi-Peak (QP)
<b>FREQUENCY RANGE</b>	30MHz ~ 1GHz	<b>TEST MODE</b>	B

**ANTENNA POLARITY & TEST DISTANCE: HORIZONTAL AT 3 M**

NO.	FREQ. (MHz)	EMISSION LEVEL (dBuV/m)	LIMIT (dBuV/m)	MARGIN (dB)	ANTENNA HEIGHT (m)	TABLE ANGLE (Degree)	RAW VALUE (dBuV)	CORRECTION FACTOR (dB/m)
1	57.12	30.6 QP	40.0	-9.4	2.00 H	139	45.40	-14.80
2	150.45	30.1 QP	43.5	-13.4	2.00 H	61	44.10	-14.00
3	374.04	34.4 QP	46.0	-11.6	1.00 H	39	45.40	-11.00
4	624.85	33.1 QP	46.0	-12.9	1.49 H	314	38.50	-5.40
5	747.34	39.5 QP	46.0	-6.5	1.00 H	54	42.70	-3.20
6	875.67	39.6 QP	46.0	-6.4	1.49 H	252	40.50	-0.90

**ANTENNA POLARITY & TEST DISTANCE: VERTICAL AT 3 M**

NO.	FREQ. (MHz)	EMISSION LEVEL (dBuV/m)	LIMIT (dBuV/m)	MARGIN (dB)	ANTENNA HEIGHT (m)	TABLE ANGLE (Degree)	RAW VALUE (dBuV)	CORRECTION FACTOR (dB/m)
1	30.29	38.9 QP	40.0	-1.1	1.00 V	27	55.00	-16.10
2	47.40	37.0 QP	40.0	-3.0	1.00 V	340	51.60	-14.60
3	80.45	33.9 QP	40.0	-6.1	1.49 V	176	52.70	-18.80
4	109.62	33.5 QP	43.5	-10.0	1.00 V	179	51.00	-17.50
5	374.04	35.9 QP	46.0	-10.1	1.49 V	78	46.90	-11.00
6	875.67	37.7 QP	46.0	-8.3	1.00 V	163	38.60	-0.90

**REMARKS:**

1. Emission Level(dBuV/m) = Raw Value(dBuV) + Correction Factor(dB/m)
2. Correction Factor(dB/m) = Antenna Factor(dB/m) + Cable Factor(dB)
3. The other emission levels were very low against the limit.
4. Margin value = Emission Level – Limit value



## 4.2 Conducted Emission Measurement

### 4.2.1 Limits of Conducted Emission Measurement

Frequency (MHz)	Conducted Limit (dBuV)	
	Quasi-peak	Average
0.15 - 0.5	66 - 56	56 - 46
0.50 - 5.0	56	46
5.0 - 30.0	60	50

Note: 1. The lower limit shall apply at the transition frequencies.

2. The limit decreases in line with the logarithm of the frequency in the range of 0.15 to 0.50MHz.

### 4.2.2 Test Instruments

Description & Manufacturer	Model No.	Serial No.	Date Of Calibration	Due Date Of Calibration
Test Receiver ROHDE & SCHWARZ	ESCI	100613	Nov. 11, 2014	Nov. 10, 2015
RF signal cable (with 10dB PAD) Woken	5D-FB	Cable-cond1-01	Dec. 26, 2014	Dec. 25, 2015
LISN ROHDE & SCHWARZ (EUT)	ESH3-Z5	835239/001	Feb. 26, 2015	Feb. 25, 2016
LISN ROHDE & SCHWARZ (Peripheral)	ESH3-Z5	100311	Jul. 24, 2015	Jul. 23, 2016
Software ADT	BV ADT_Cond_ V7.3.7.3	NA	NA	NA

**NOTE:** 1. The calibration interval of the above test instruments is 12 months and the calibrations are traceable to NML/ROC and NIST/USA.

2. The test was performed in HwaYa Shielded Room 1.

3. The VCCI Site Registration No. is C-2040.

### 4.2.3 Test Procedures

- The EUT was placed 0.4 meters from the conducting wall of the shielded room with EUT being connected to the power mains through a line impedance stabilization network (LISN). Other support units were connected to the power mains through another LISN. The two LISNs provide 50 ohm/ 50uH of coupling impedance for the measuring instrument.
- Both lines of the power mains connected to the EUT were checked for maximum conducted interference.
- The frequency range from 150kHz to 30MHz was searched. Emission levels under (Limit - 20dB) was not recorded.

**NOTE:** The resolution bandwidth and video bandwidth of test receiver is 9kHz for quasi-peak detection (QP) and average detection (AV) at frequency 0.15MHz-30MHz.

### 4.2.4 Deviation from Test Standard

No deviation.

#### 4.2.5 Test Setup

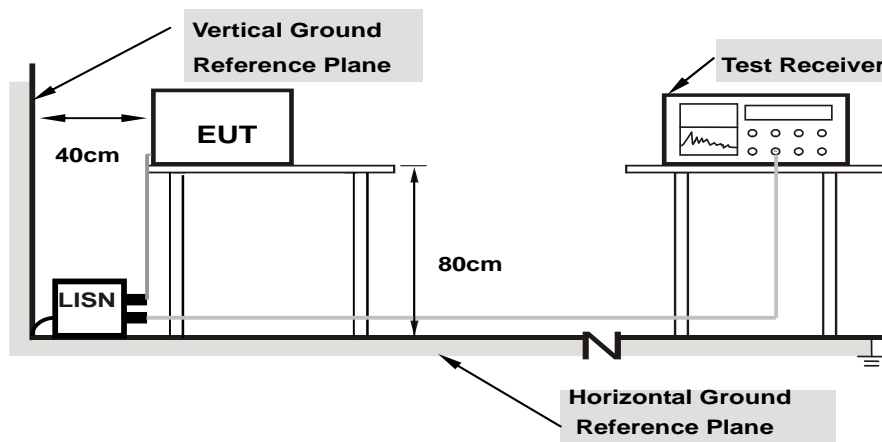

**Note: 1.Support units were connected to second LISN.**

For the actual test configuration, please refer to the attached file (Test Setup Photo).

#### 4.2.6 EUT Operating Conditions

Same as 4.1.6.

#### 4.2.7 Test Results

Phase	Line (L)	Detector Function	Quasi-Peak (QP) / Average (AV)
Test Mode	A		

No	Freq. [MHz]	Corr. Factor (dB)	Reading Value [dB (uV)]		Emission Level [dB (uV)]		Limit [dB (uV)]		Margin (dB)	
			Q.P.	AV.	Q.P.	AV.	Q.P.	AV.	Q.P.	AV.
			1	0.46813	9.91	35.83	25.98	45.74	35.89	56.55
2	0.88200	10.00	26.24	16.99	36.24	26.99	56.00	46.00	-19.76	-19.01
3	1.29800	10.05	24.07	17.17	34.12	27.22	56.00	46.00	-21.88	-18.78
4	2.90600	10.14	32.80	28.09	42.94	38.23	56.00	46.00	-13.06	-7.77
5	19.38600	11.11	25.93	25.15	37.04	36.26	60.00	50.00	-22.96	-13.74
6	24.95800	11.34	26.46	24.21	37.80	35.55	60.00	50.00	-22.20	-14.45

**REMARKS:**

1. Q.P. and AV. are abbreviations of quasi-peak and average individually.
2. The emission levels of other frequencies were very low against the limit.
3. Margin value = Emission level - Limit value
4. Correction factor = Insertion loss + Cable loss
5. Emission Level = Correction Factor + Reading Value.

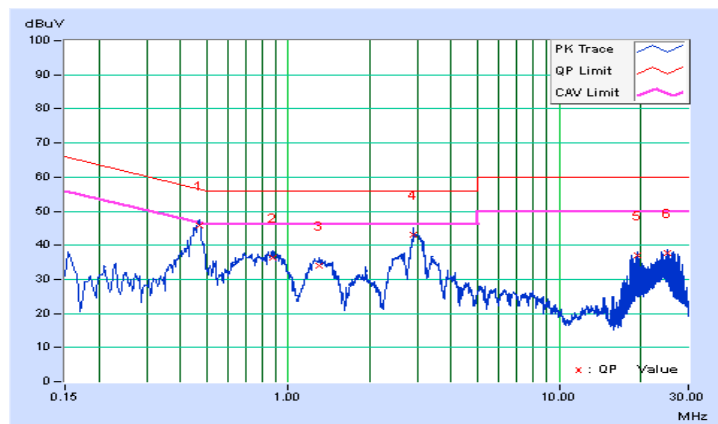

Phase	Neutral (N)	Detector Function	Quasi-Peak (QP) / Average (AV)
Test Mode	A		

No	Freq. [MHz]	Corr. Factor (dB)	Reading Value [dB (uV)]		Emission Level [dB (uV)]		Limit [dB (uV)]		Margin (dB)	
			Q.P.	AV.	Q.P.	AV.	Q.P.	AV.	Q.P.	AV.
	1	0.46600	9.99	32.92	21.59	42.91	31.58	56.58	46.58	-13.67
2	0.71000	10.01	21.86	12.31	31.87	22.32	56.00	46.00	-24.13	-23.68
3	1.27800	10.05	20.82	12.64	30.87	22.69	56.00	46.00	-25.13	-23.31
<b>4</b>	<b>2.90594</b>	<b>10.20</b>	<b>33.71</b>	<b>28.92</b>	<b>43.91</b>	<b>39.12</b>	<b>56.00</b>	<b>46.00</b>	<b>-12.09</b>	<b>-6.88</b>
5	19.38600	11.02	26.28	25.12	37.30	36.14	60.00	50.00	-22.70	-13.86
6	27.62600	11.22	24.34	22.89	35.56	34.11	60.00	50.00	-24.44	-15.89

**REMARKS:**

1. Q.P. and AV. are abbreviations of quasi-peak and average individually.
2. The emission levels of other frequencies were very low against the limit.
3. Margin value = Emission level - Limit value
4. Correction factor = Insertion loss + Cable loss
5. Emission Level = Correction Factor + Reading Value.

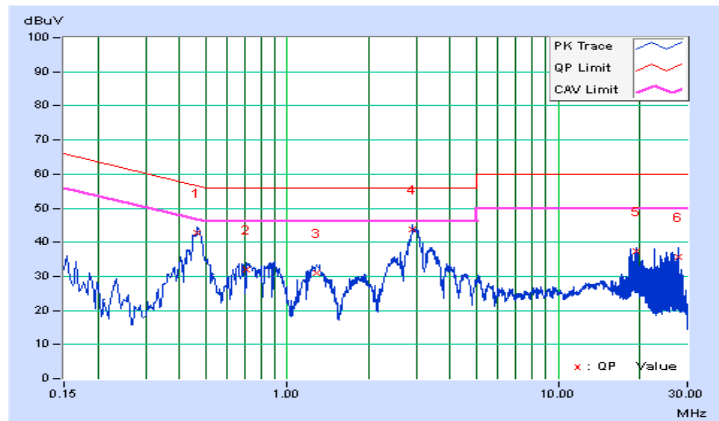

Phase	Line (L)	Detector Function	Quasi-Peak (QP) / Average (AV)
Test Mode	B		

No	Freq. [MHz]	Corr. Factor (dB)	Reading Value [dB (uV)]		Emission Level [dB (uV)]		Limit [dB (uV)]		Margin (dB)	
			Q.P.	AV.	Q.P.	AV.	Q.P.	AV.	Q.P.	AV.
			1	0.45837	9.91	34.90	22.96	44.81	32.87	56.72
2	0.64220	9.95	26.52	17.09	36.47	27.04	56.00	46.00	-19.53	-18.96
3	0.84600	10.00	26.57	17.76	36.57	27.76	56.00	46.00	-19.43	-18.24
4	1.22200	10.05	24.95	17.27	35.00	27.32	56.00	46.00	-21.00	-18.68
5	2.84200	10.14	28.75	24.04	38.89	34.18	56.00	46.00	-17.11	-11.82
6	24.70200	11.33	24.18	21.87	35.51	33.20	60.00	50.00	-24.49	-16.80

**REMARKS:**

1. Q.P. and AV. are abbreviations of quasi-peak and average individually.
2. The emission levels of other frequencies were very low against the limit.
3. Margin value = Emission level - Limit value
4. Correction factor = Insertion loss + Cable loss
5. Emission Level = Correction Factor + Reading Value.

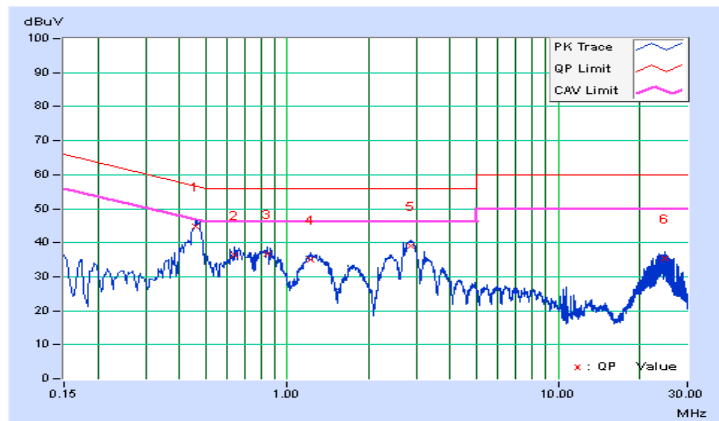

Phase	Neutral (N)	Detector Function	Quasi-Peak (QP) / Average (AV)
Test Mode	B		

No	Freq. [MHz]	Corr. Factor (dB)	Reading Value [dB (uV)]		Emission Level [dB (uV)]		Limit [dB (uV)]		Margin (dB)	
			Q.P.	AV.	Q.P.	AV.	Q.P.	AV.	Q.P.	AV.
			1	0.46322	9.99	32.53	20.59	42.52	30.58	56.63
2	0.64900	10.01	22.72	11.86	32.73	21.87	56.00	46.00	-23.27	-24.13
3	0.84600	10.02	22.34	12.63	32.36	22.65	56.00	46.00	-23.64	-23.35
4	1.26600	10.05	21.12	12.82	31.17	22.87	56.00	46.00	-24.83	-23.13
5	2.84533	10.19	29.61	24.97	39.80	35.16	56.00	46.00	-16.20	-10.84
6	24.70200	11.16	22.56	22.05	33.72	33.21	60.00	50.00	-26.28	-16.79

**REMARKS:**

1. Q.P. and AV. are abbreviations of quasi-peak and average individually.
2. The emission levels of other frequencies were very low against the limit.
3. Margin value = Emission level - Limit value
4. Correction factor = Insertion loss + Cable loss
5. Emission Level = Correction Factor + Reading Value.

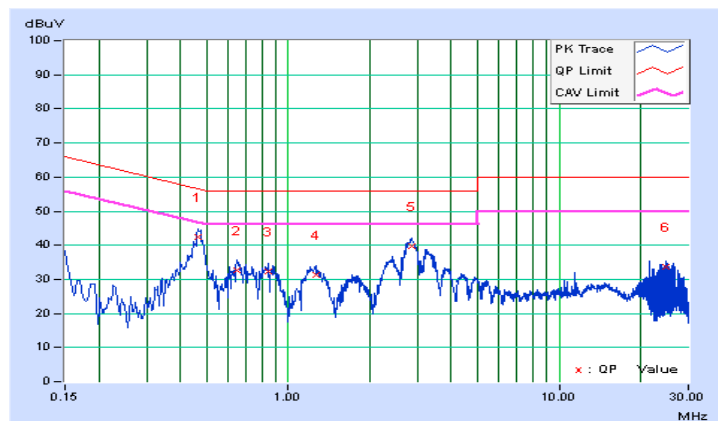

### 4.3 6dB Bandwidth Measurement

#### 4.3.1 Limits of 6dB Bandwidth Measurement

The minimum of 6dB Bandwidth Measurement is 0.5 MHz.

#### 4.3.2 Test Setup

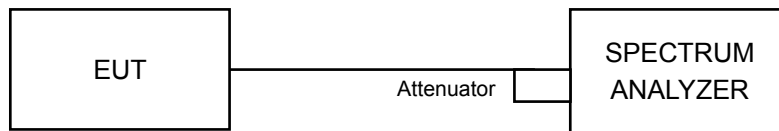

#### 4.3.3 Test Instruments

Refer to section 4.1.2 to get information of above instrument.

#### 4.3.4 Test Procedure

- a. Set resolution bandwidth (RBW) = 100kHz
- b. Set the video bandwidth (VBW)  $\geq 3 \times$  RBW, Detector = Peak.
- c. Trace mode = max hold.
- d. Sweep = auto couple.
- e. Measure the maximum width of the emission that is constrained by the frequencies associated with the two amplitude points (upper and lower) that are attenuated by 6 dB relative to the maximum level measured in the fundamental emission

#### 4.3.5 Deviation from Test Standard

No deviation.

#### 4.3.6 EUT Operating Conditions

The software provided by client to enable the EUT under transmission condition continuously at lowest, middle and highest channel frequencies individually.

#### 4.3.7 Test Result

##### 802.11b

Channel	Frequency (MHz)	6dB Bandwidth (MHz)		Minimum Limit (MHz)	Pass / Fail
		Chain 0	Chain 1		
1	2412	10.11	10.12	0.5	PASS
6	2437	10.12	10.12	0.5	PASS
11	2462	10.12	10.11	0.5	PASS

##### 802.11g

Channel	Frequency (MHz)	6dB Bandwidth (MHz)		Minimum Limit (MHz)	Pass / Fail
		Chain 0	Chain 1		
1	2412	16.61	16.39	0.5	PASS
6	2437	16.59	16.37	0.5	PASS
11	2462	16.61	16.39	0.5	PASS

##### 802.11n (HT20)

Channel	Frequency (MHz)	6dB Bandwidth (MHz)		Minimum Limit (MHz)	Pass / Fail
		Chain 0	Chain 1		
1	2412	17.63	17.62	0.5	PASS
6	2437	16.97	17.29	0.5	PASS
11	2462	17.36	17.60	0.5	PASS

##### 802.11n (HT40)

Channel	Frequency (MHz)	6dB Bandwidth (MHz)		Minimum Limit (MHz)	Pass / Fail
		Chain 0	Chain 1		
3	2422	36.49	36.50	0.5	PASS
6	2437	36.48	36.47	0.5	PASS
9	2452	36.46	36.48	0.5	PASS

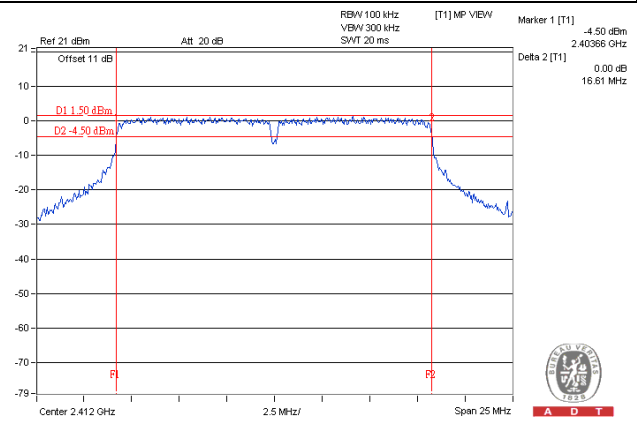
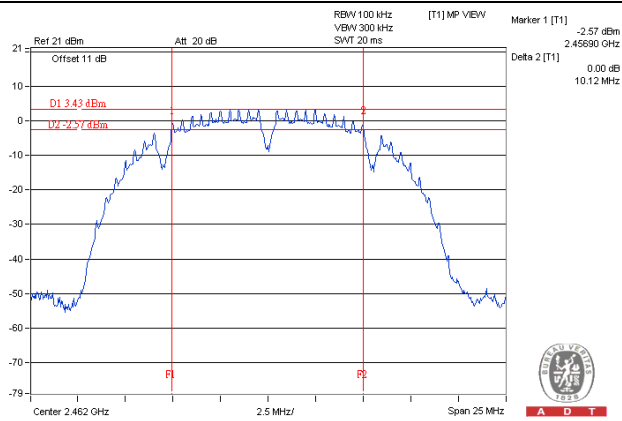
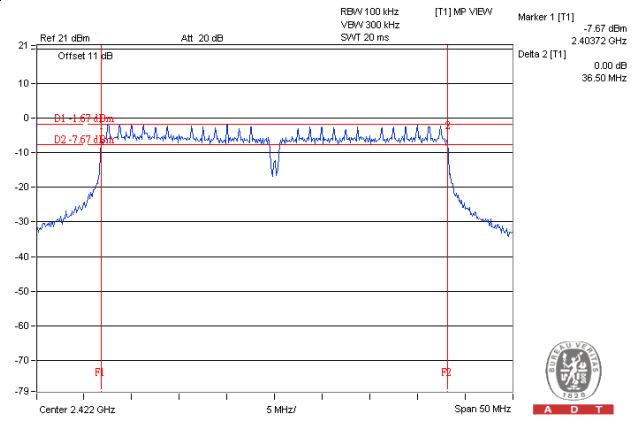
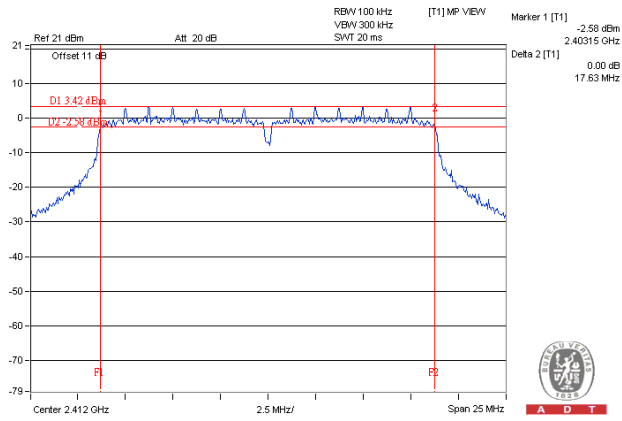

**Spectrum Plot of Worst Value****802.11b****802.11g****802.11n (HT20)****802.11n (HT40)**

## 4.4 Conducted Output Power Measurement

### 4.4.1 Limits of Conducted Output Power Measurement

For systems using digital modulation in the 2400–2483.5 MHz bands: 1 Watt (30dBm)

Per KDB 662911 D01 Multiple Transmitter Output Method of conducted output power measurement on IEEE 802.11 devices,

Array Gain = 0 dB (i.e., no array gain) for  $N_{ANT} \leq 4$ ;

Array Gain = 0 dB (i.e., no array gain) for channel widths  $\geq 40$  MHz for any  $N_{ANT}$ ;

Array Gain =  $5 \log(N_{ANT}/N_{SS})$  dB or 3 dB, whichever is less for 20-MHz channel widths with  $N_{ANT} \geq 5$ .

For power measurements on all other devices: Array Gain =  $10 \log(N_{ANT}/N_{SS})$  dB.

### 4.4.2 Test Setup

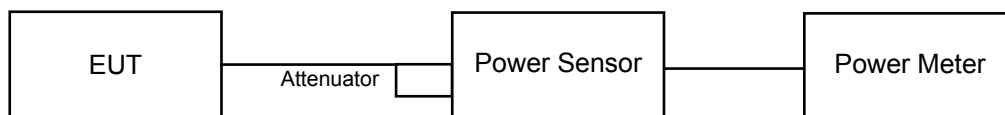

### 4.4.3 Test Instruments

Refer to section 4.1.2 to get information of above instrument.

### 4.4.4 Test Procedures

A peak / average power sensor was used on the output port of the EUT. A power meter was used to read the response of the peak / average power sensor. Record the power level.

### 4.4.5 Deviation from Test Standard

No deviation.

### 4.4.6 EUT Operating Conditions

Same as Item 4.3.6.

#### 4.4.7 Test Results

### FOR PEAK POWER

#### 802.11b

Chan.	Freq. (MHz)	Peak Power (dBm)		Total Power (mW)	Total Power (dBm)	Limit (dBm)	Pass / Fail
		Chain 0	Chain 1				
1	2412	16.82	17.15	99.964	20.00	30	Pass
6	2437	17.09	16.97	100.942	20.04	30	Pass
11	2462	15.83	15.44	73.277	18.65	30	Pass

#### 802.11g

Chan.	Freq. (MHz)	Peak Power (dBm)		Total Power (mW)	Total Power (dBm)	Limit (dBm)	Pass / Fail
		Chain 0	Chain 1				
1	2412	23.01	22.02	359.207	25.55	30	Pass
6	2437	24.29	23.73	504.582	27.03	30	Pass
11	2462	22.42	21.93	330.537	25.19	30	Pass

#### 802.11n (HT20)

Chan.	Freq. (MHz)	Peak Power (dBm)		Total Power (mW)	Total Power (dBm)	Limit (dBm)	Pass / Fail
		Chain 0	Chain 1				
1	2412	22.07	21.70	308.976	24.90	30	Pass
6	2437	24.36	23.65	<b>504.637</b>	27.03	30	Pass
11	2462	22.40	21.68	321.011	25.07	30	Pass

#### 802.11n (HT40)

Chan.	Freq. (MHz)	Peak Power (dBm)		Total Power (mW)	Total Power (dBm)	Limit (dBm)	Pass / Fail
		Chain 0	Chain 1				
3	2422	21.26	21.25	267.012	24.27	30	Pass
6	2437	22.56	21.23	313.041	24.96	30	Pass
9	2452	21.77	21.33	286.145	24.57	30	Pass

**FOR AVERAGE POWER**
**802.11b**

Chan.	Frequency (MHz)	Avg. Power (dBm)		Total Power (mW)	Total Power (dBm)
		Chain 0	Chain 1		
1	2412	14.49	14.87	58.809	17.69
6	2437	14.82	14.72	59.987	17.78
11	2462	13.59	13.15	43.510	16.39

**802.11g**

Chan.	Frequency (MHz)	Avg. Power (dBm)		Total Power (mW)	Total Power (dBm)
		Chain 0	Chain 1		
1	2412	15.89	15.32	72.856	18.62
6	2437	20.71	19.50	206.886	23.16
11	2462	15.21	14.66	62.431	17.95

**802.11n (HT20)**

Chan.	Frequency (MHz)	Avg. Power (dBm)		Total Power (mW)	Total Power (dBm)
		Chain 0	Chain 1		
1	2412	14.60	13.93	53.557	17.29
6	2437	20.73	19.44	206.206	23.14
11	2462	14.53	14.01	53.556	17.29

**802.11n (HT40)**

Chan.	Frequency (MHz)	Avg. Power (dBm)		Total Power (mW)	Total Power (dBm)
		Chain 0	Chain 1		
3	2422	12.78	12.51	36.791	15.66
6	2437	14.83	14.01	55.586	17.45
9	2452	11.84	11.60	29.730	14.73

## 4.5 Power Spectral Density Measurement

### 4.5.1 Limits of Power Spectral Density Measurement

The Maximum of Power Spectral Density Measurement is 8dBm.

### 4.5.2 Test Setup

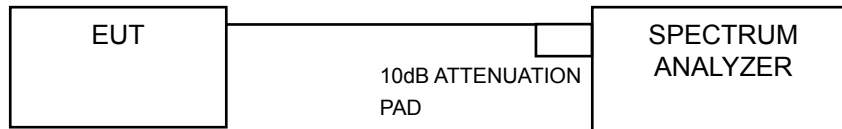

### 4.5.3 Test Instruments

Refer to section 4.1.2 to get information of above instrument.

### 4.5.4 Test Procedure

- a. Set analyzer center frequency to DTS channel center frequency.
- b. Set the span to 1.5 times the DTS bandwidth.
- c. Set the RBW to:  $3 \text{ kHz} \leq \text{RBW} \leq 100 \text{ kHz}$ .
- d. Set the VBW  $\geq 3 \times \text{RBW}$ .
- e. Detector = peak.
- f. Sweep time = auto couple.
- g. Trace mode = max hold.
- h. Allow trace to fully stabilize.
- i. Use the peak marker function to determine the maximum amplitude level within the RBW.

### 4.5.5 Deviation from Test Standard

No deviation.

### 4.5.6 EUT Operating Condition

Same as Item 4.3.6

#### 4.5.7 Test Results

##### 802.11b

TX chain	Channel	Freq. (MHz)	PSD (dBm)	10 log (N=2) dB	Total PSD (dBm)	Limit (dBm)	Pass /Fail
0	1	2412	-9.45	3.01	-6.44	6.12	Pass
	6	2437	-8.07	3.01	-5.06	6.12	Pass
	11	2462	-10.48	3.01	-7.47	6.12	Pass
1	1	2412	-8.30	3.01	-5.29	6.12	Pass
	6	2437	-7.64	3.01	-4.63	6.12	Pass
	11	2462	-8.99	3.01	-5.98	6.12	Pass

**NOTE:** Directional gain =  $10 \log[(10^{G1/10} + 10^{G2/10} + \dots + 10^{GN/10})/N_{ANT}] = 7.88\text{dBi} > 6\text{dBi}$ , so the power density limit shall be reduced to  $8-(7.88-6) = 6.12\text{dBm}$ .

##### 802.11g

TX chain	Channel	Freq. (MHz)	PSD (dBm)	10 log (N=2) dB	Total PSD (dBm)	Limit (dBm)	Pass /Fail
0	1	2412	-10.19	3.01	-7.18	6.12	Pass
	6	2437	-5.10	3.01	-2.09	6.12	Pass
	11	2462	-11.19	3.01	-8.18	6.12	Pass
1	1	2412	-9.58	3.01	-6.57	6.12	Pass
	6	2437	-5.62	3.01	-2.61	6.12	Pass
	11	2462	-10.73	3.01	-7.72	6.12	Pass

**NOTE:**

- Method 1 of power density measurement of KDB 662911 is using for calculating total power density. Total power density is summing entire spectra across corresponding frequency bins on the various outputs by computer.
- Directional gain =  $10 \log[(10^{G1/10} + 10^{G2/10} + \dots + 10^{GN/10})/N_{ANT}] = 7.88\text{dBi} > 6\text{dBi}$ , so the power density limit shall be reduced to  $8-(7.88-6) = 6.12\text{dBm}$ .

##### 802.11n (HT20)

TX chain	Channel	Freq. (MHz)	PSD (dBm)	10 log (N=2) dB	Total PSD (dBm)	Limit (dBm)	Pass /Fail
0	1	2412	-11.86	3.01	-8.85	6.12	Pass
	6	2437	-5.86	3.01	-2.85	6.12	Pass
	11	2462	-11.51	3.01	-8.50	6.12	Pass
1	1	2412	-11.56	3.01	-8.55	6.12	Pass
	6	2437	-5.71	3.01	-2.70	6.12	Pass
	11	2462	-10.81	3.01	-7.80	6.12	Pass

**NOTE:**

- Method 1 of power density measurement of KDB 662911 is using for calculating total power density. Total power density is summing entire spectra across corresponding frequency bins on the various outputs by computer.
- Directional gain =  $10 \log[(10^{G1/10} + 10^{G2/10} + \dots + 10^{GN/10})/N_{ANT}] = 7.88\text{dBi} > 6\text{dBi}$ , so the power density limit shall be reduced to  $8-(7.88-6) = 6.12\text{dBm}$ .

### 802.11n (HT40)

TX chain	Channel	Freq. (MHz)	PSD (dBm)	10 log (N=2) dB	Total PSD (dBm)	Limit (dBm)	Pass /Fail
0	3	2422	-17.19	3.01	-14.18	6.12	Pass
	6	2437	-14.16	3.01	-11.15	6.12	Pass
	9	2452	-18.09	3.01	-15.08	6.12	Pass
1	3	2422	-16.97	3.01	-13.96	6.12	Pass
	6	2437	-14.98	3.01	-11.97	6.12	Pass
	9	2452	-17.35	3.01	-14.34	6.12	Pass

**NOTE:**

- Method 1 of power density measurement of KDB 662911 is using for calculating total power density. Total power density is summing entire spectra across corresponding frequency bins on the various outputs by computer.
- Directional gain =  $10 \log[(10^{G1/10} + 10^{G2/10} + \dots + 10^{GN/10})/N_{ANT}] = 7.88\text{dBi} > 6\text{dBi}$ , so the power density limit shall be reduced to  $8-(7.88-6) = 6.12\text{dBm}$ .

### Spectrum Plot of Worst Value

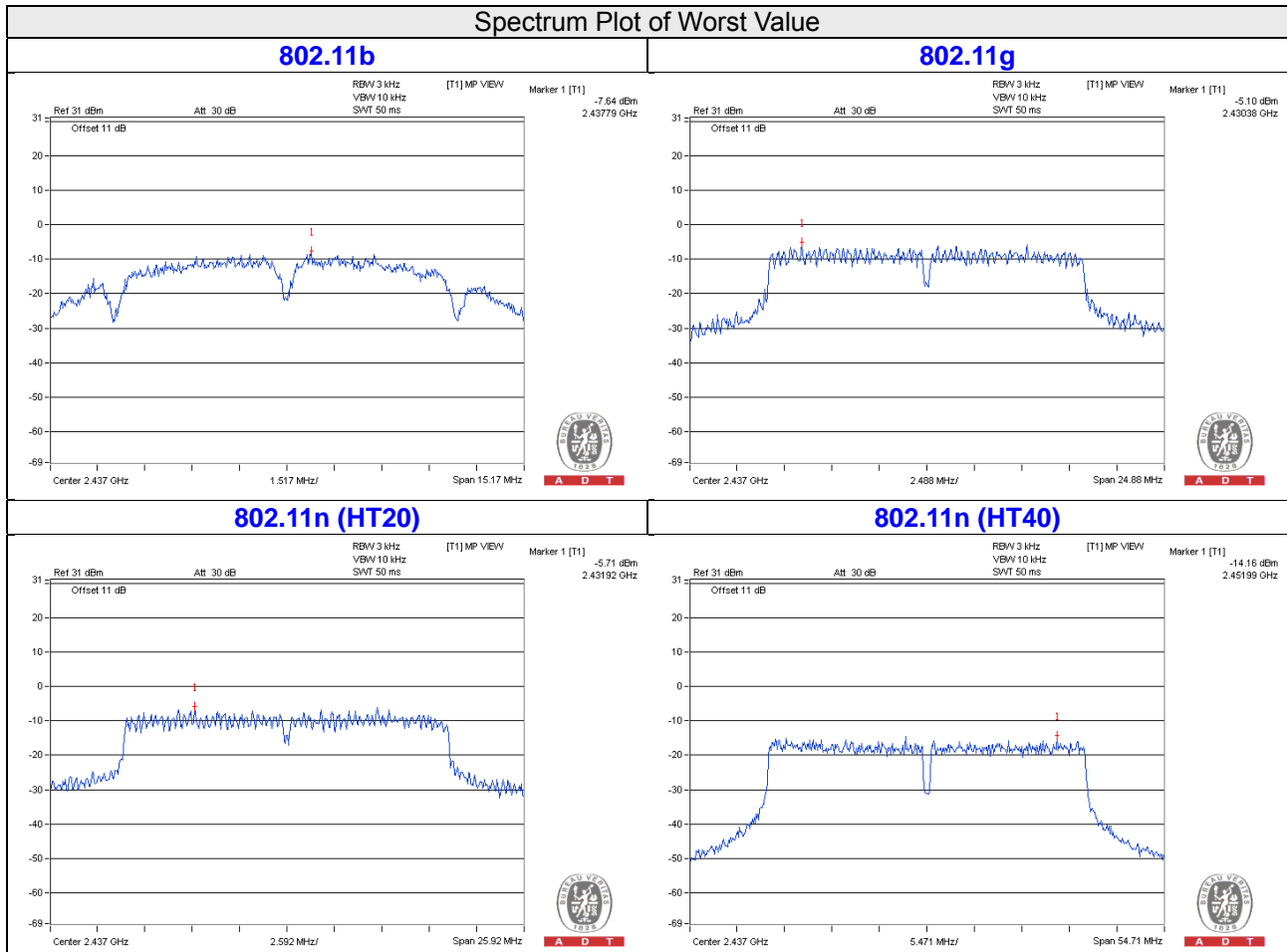

## 4.6 Conducted Out of Band Emission Measurement

### 4.6.1 Limits of Conducted Out of Band Emission Measurement

Below 20dB of the highest emission level of operating band (in 100kHz Resolution Bandwidth).

### 4.6.2 Test Setup

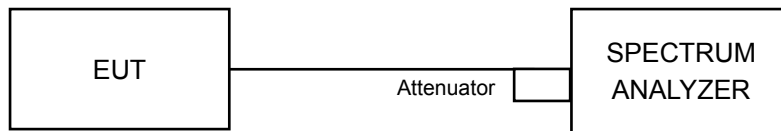

### 4.6.3 Test Instruments

Refer to section 4.1.2 to get information of above instrument.

### 4.6.4 Test Procedure

#### MEASUREMENT PROCEDURE REF

1. Set the RBW = 100 kHz.
2. Set the VBW  $\geq$  300 kHz.
3. Detector = peak.
4. Sweep time = auto couple.
5. Trace mode = max hold.
6. Allow trace to fully stabilize.
7. Use the peak marker function to determine the maximum power level in any 100 kHz band segment within the fundamental EBW.

#### MEASUREMENT PROCEDURE OOB

1. Set RBW = 100 kHz.
2. Set VBW  $\geq$  300 kHz.
3. Detector = peak.
4. Sweep = auto couple.
5. Trace Mode = max hold.
6. Allow trace to fully stabilize.
7. Use the peak marker function to determine the maximum amplitude level.

### 4.6.5 Deviation from Test Standard

No deviation.

### 4.6.6 EUT Operating Condition

Same as Item 4.3.6

### 4.6.7 Test Results

The spectrum plots are attached on the following pages. D1 line indicates the highest level, and D2 line indicates the 20dB offset below D1. It shows compliance with the requirement.



802.11b  
CHAIN 0

CH 1

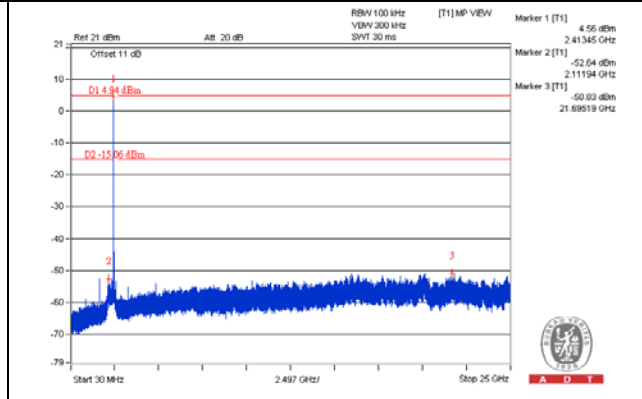
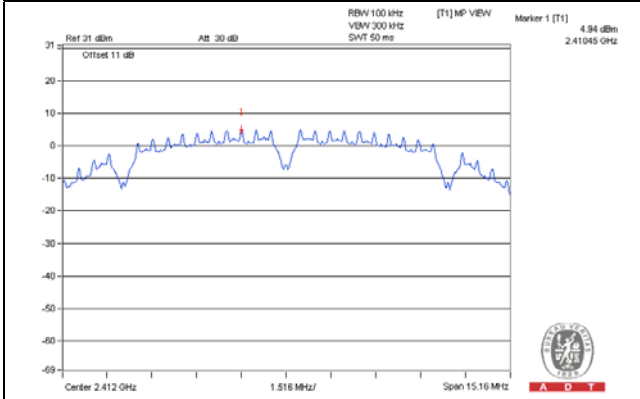

CH 6

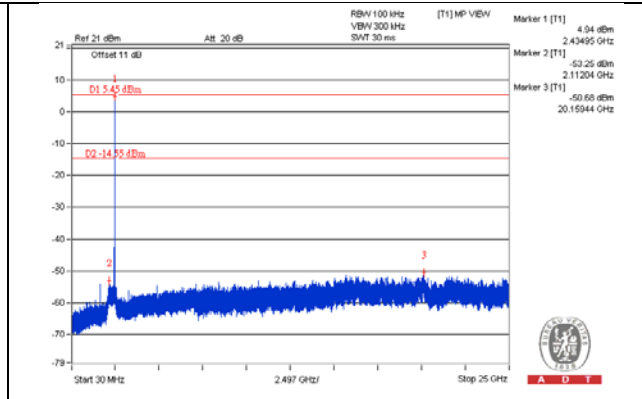
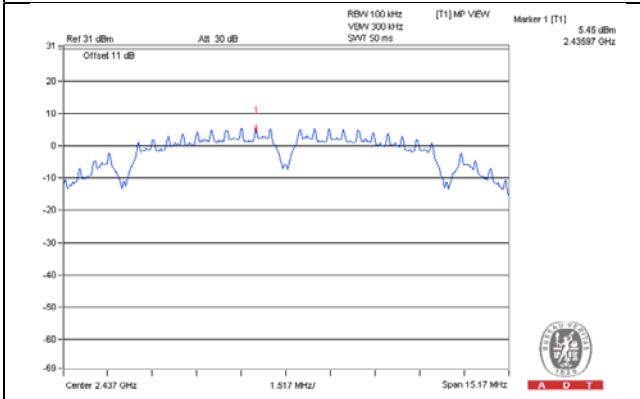

CH 11

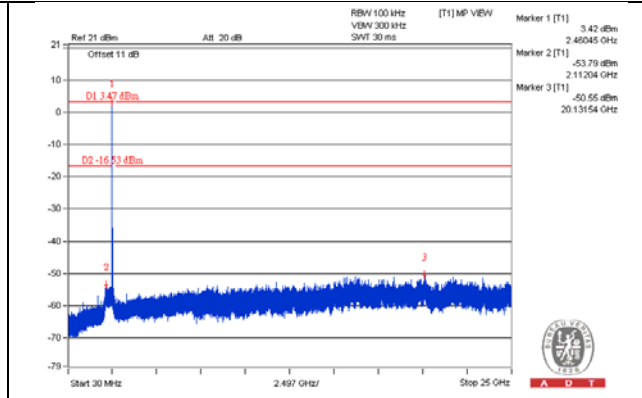
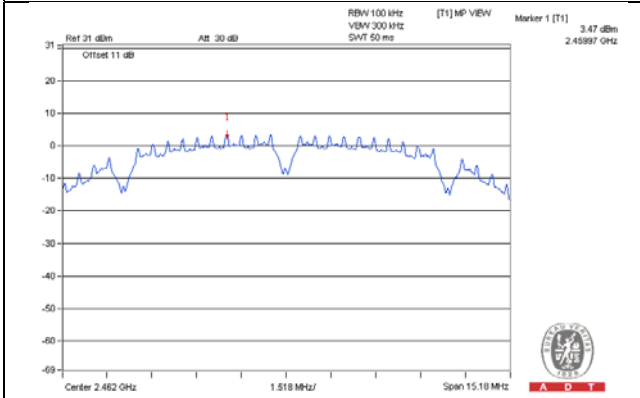

CH 1 Band edge

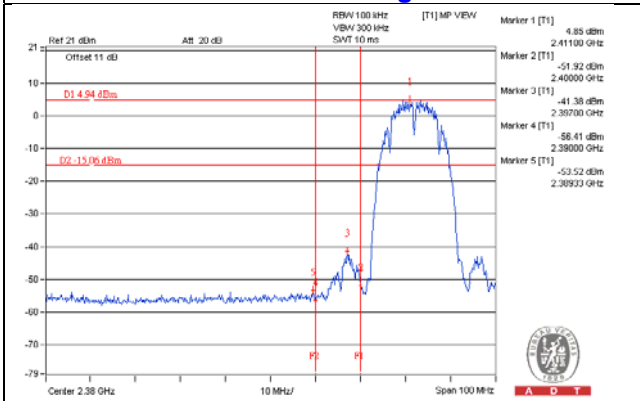

CH 11 Band edge

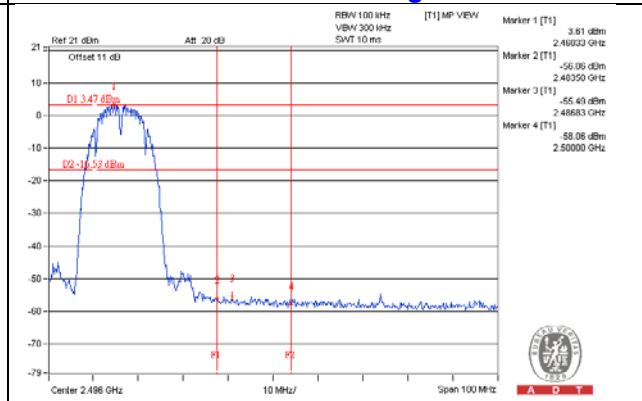

CHAIN 1

CH 1

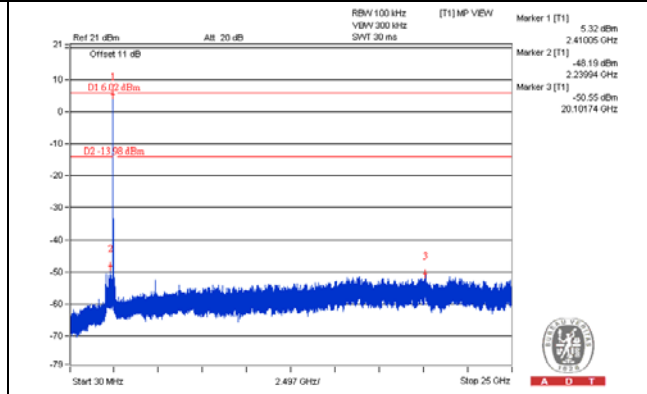
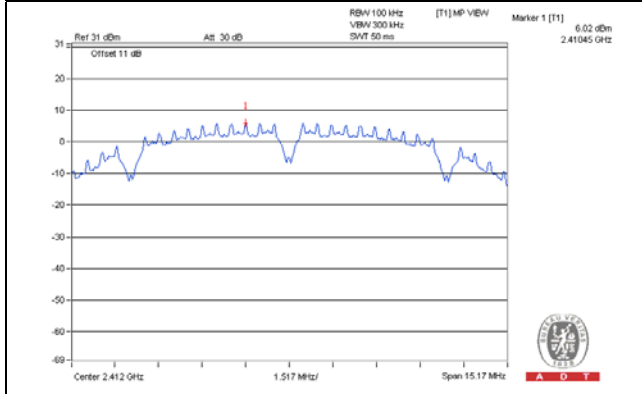

CH 6

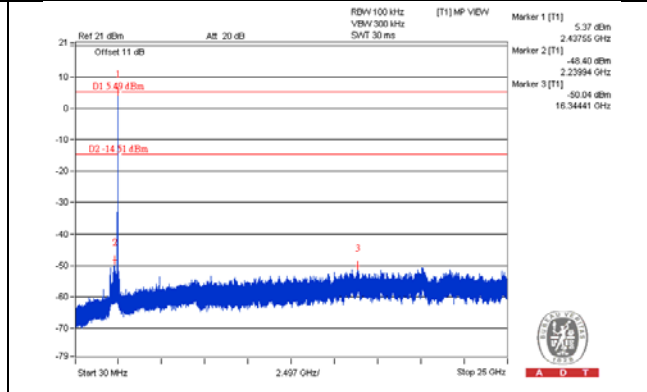
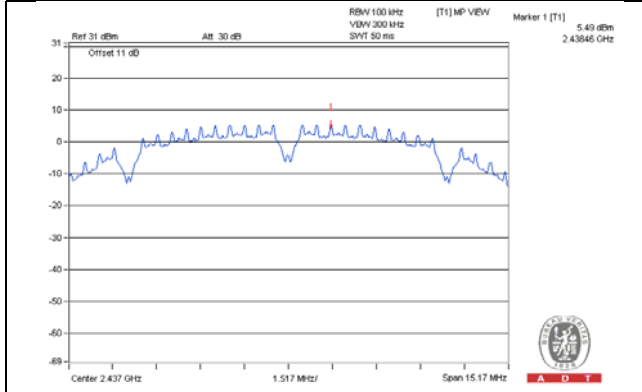

CH 11

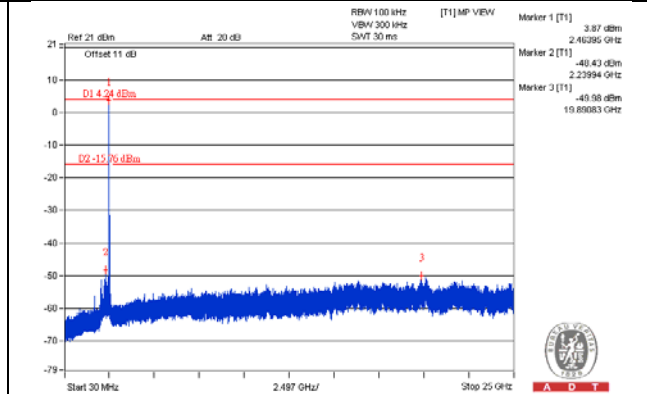
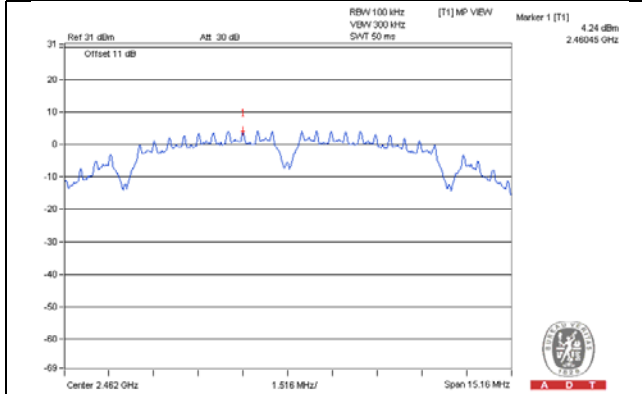

CH 1 Band edge

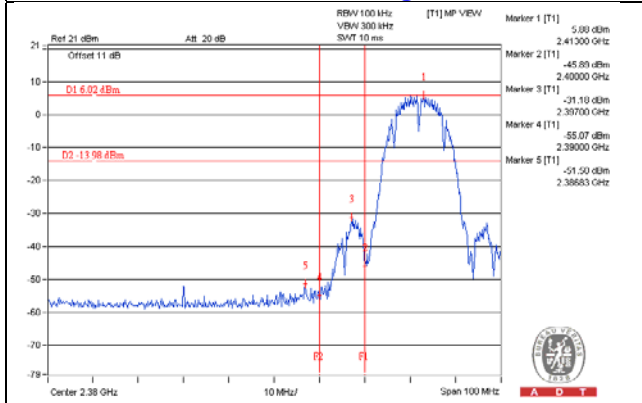

CH 11 Band edge

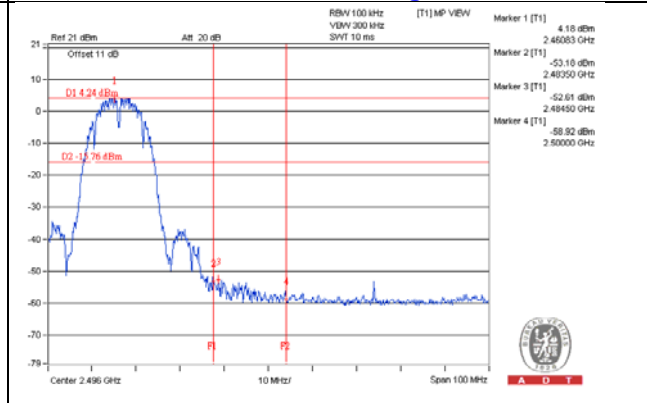

802.11g  
CHAIN 0

CH 1

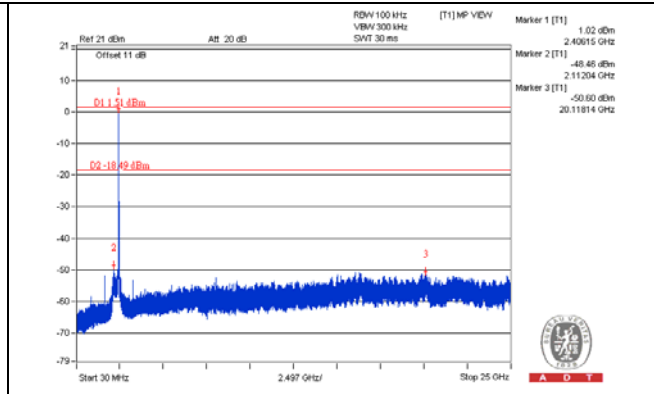
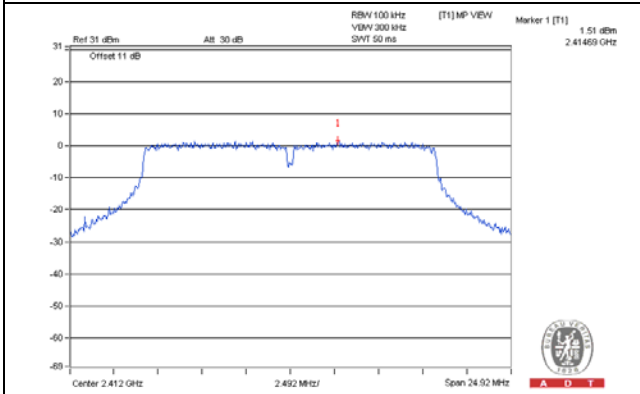

CH 6

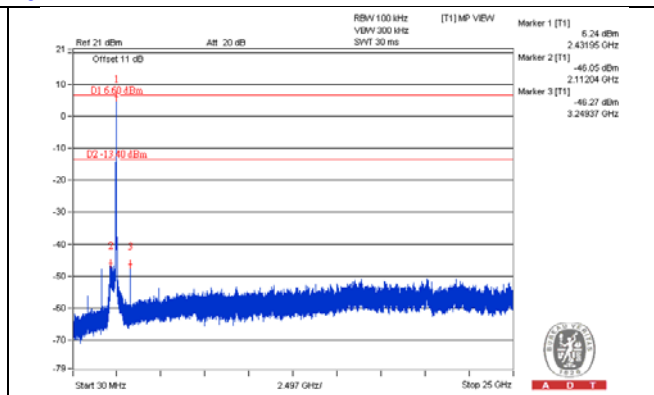
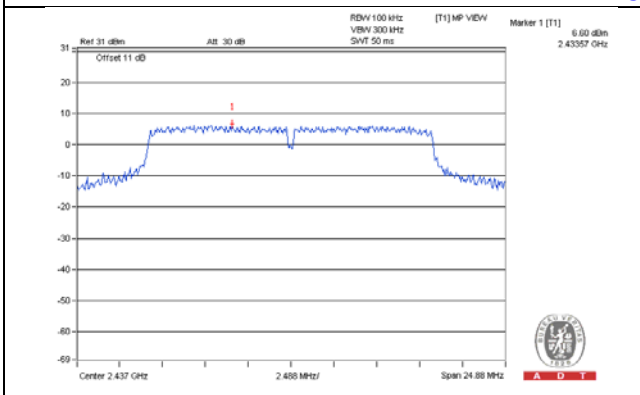

CH 11

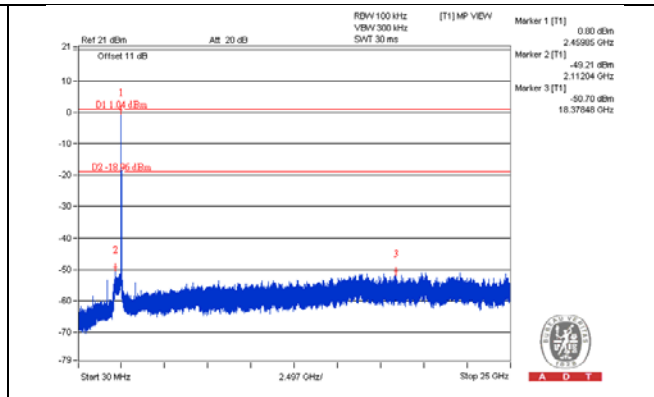
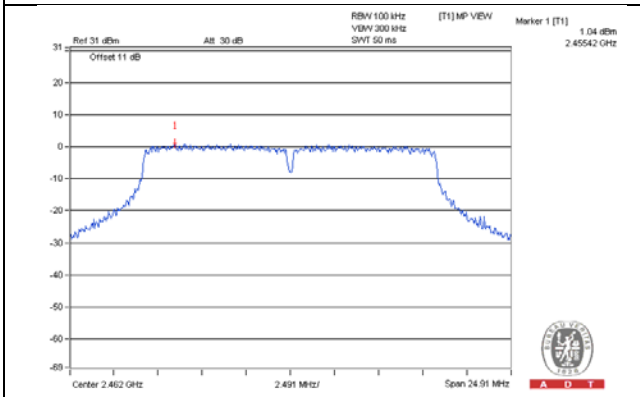

CH 1 Band edge

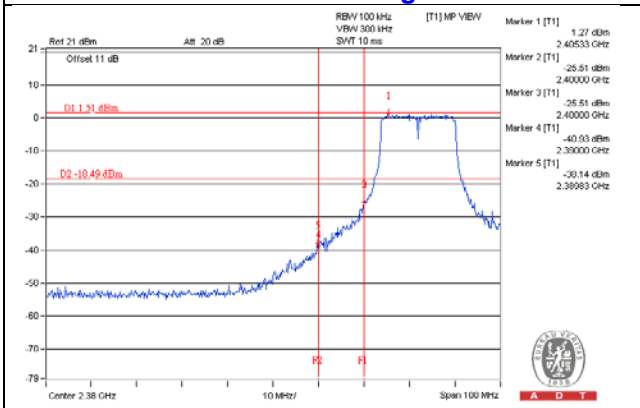

CH 11 Band edge

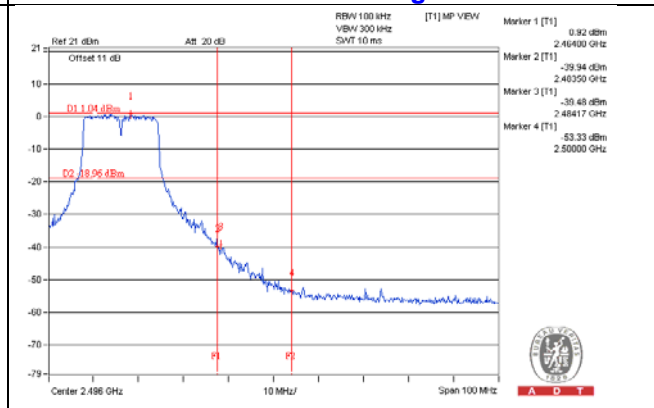

CHAIN 1

CH 1

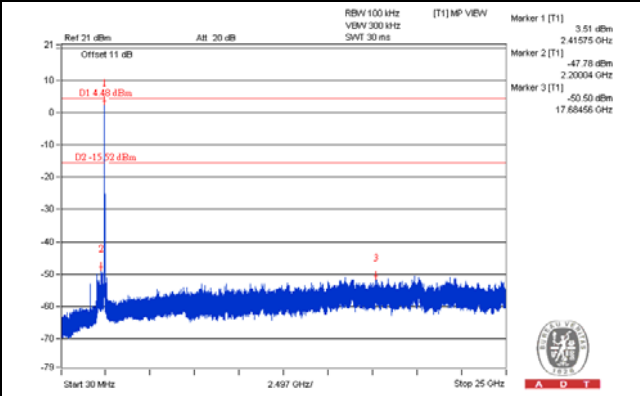
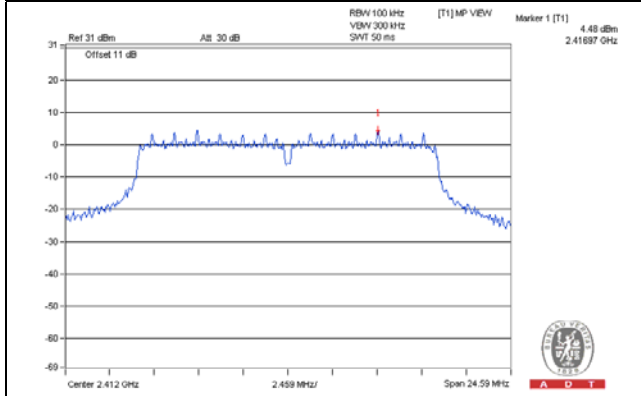

CH 6

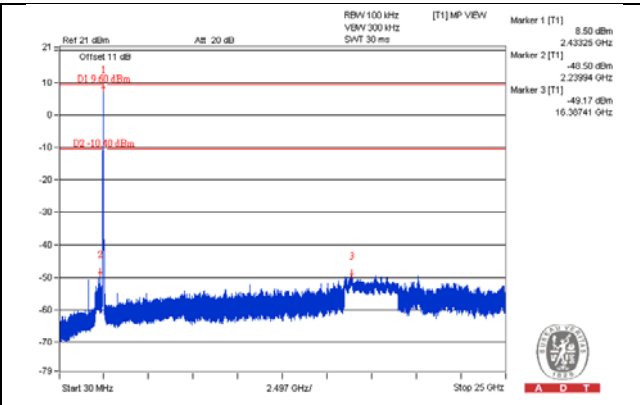
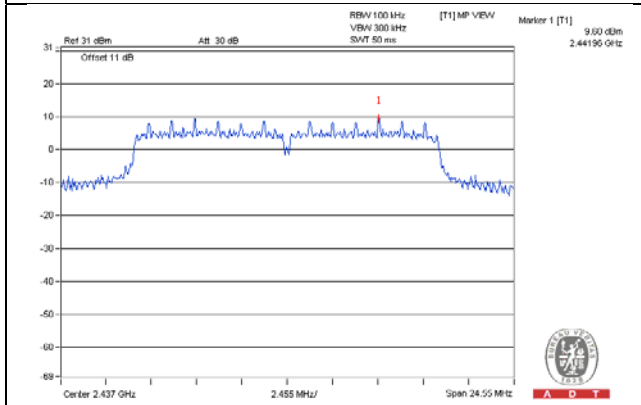

CH 11

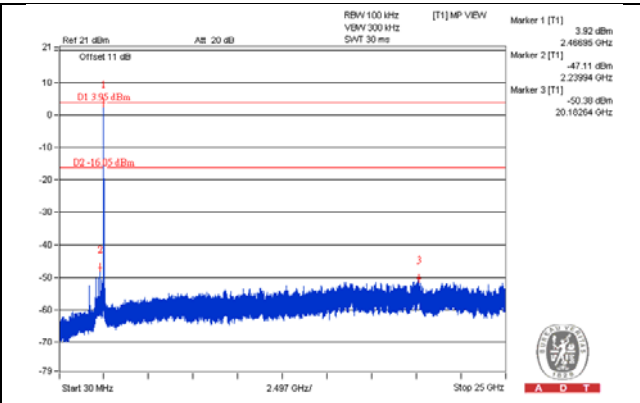
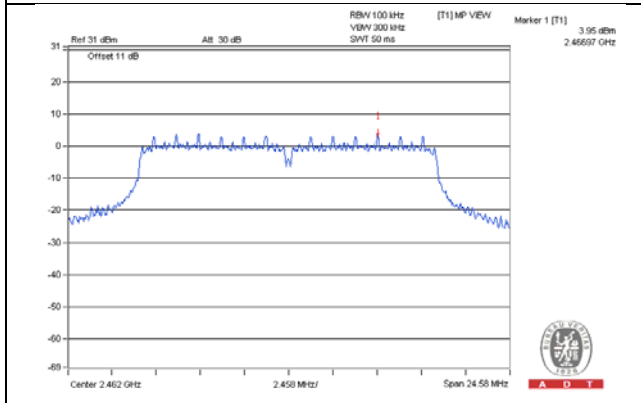

CH 1 Band edge

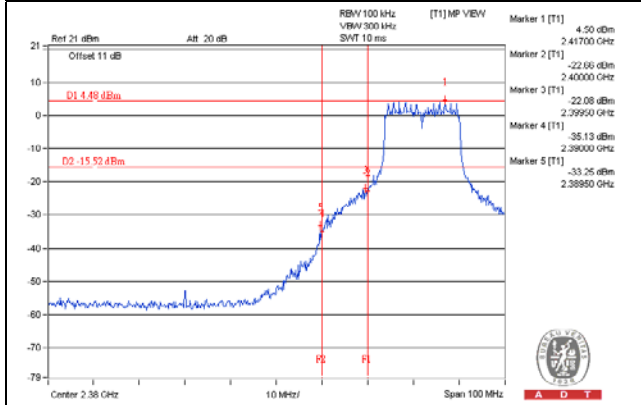

CH 11 Band edge

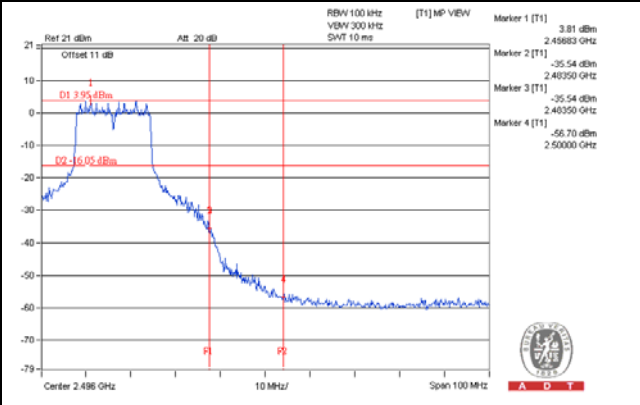

802.11n (HT20)  
CHAIN 0

CH 1

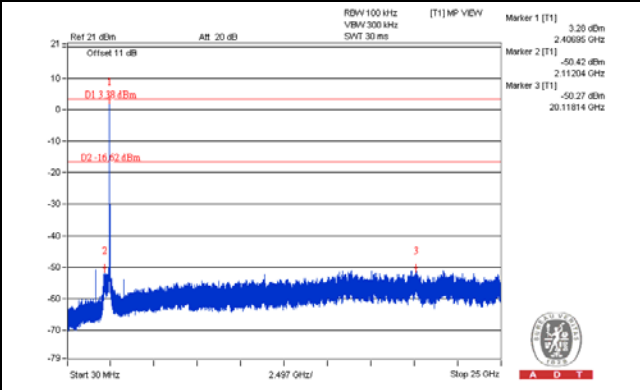
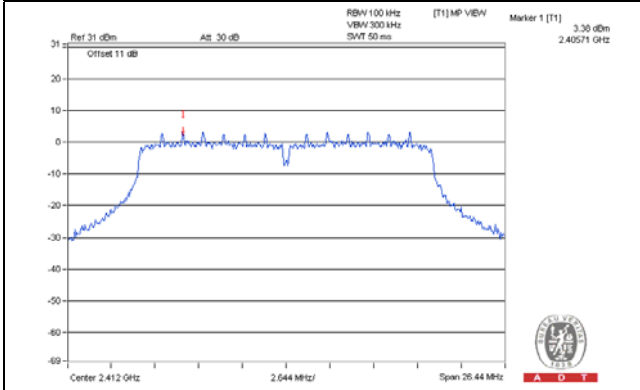

CH 6

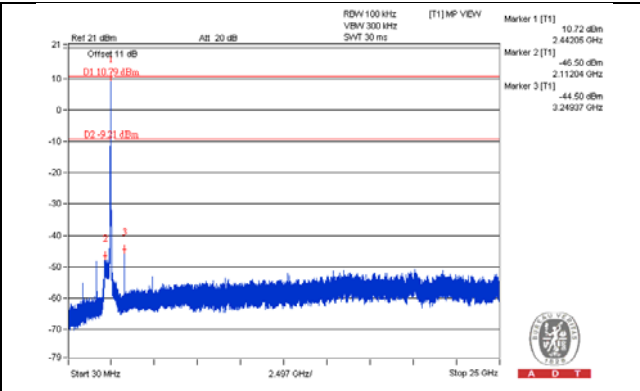
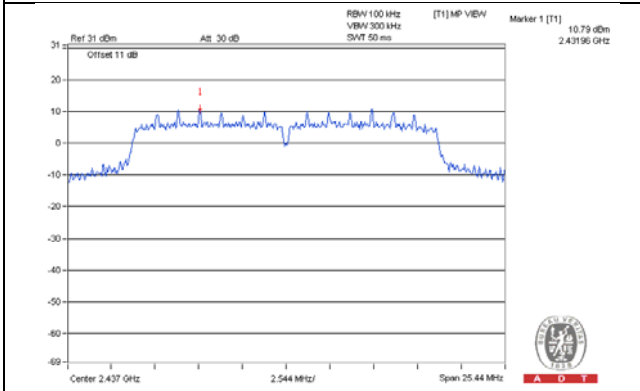

CH 11

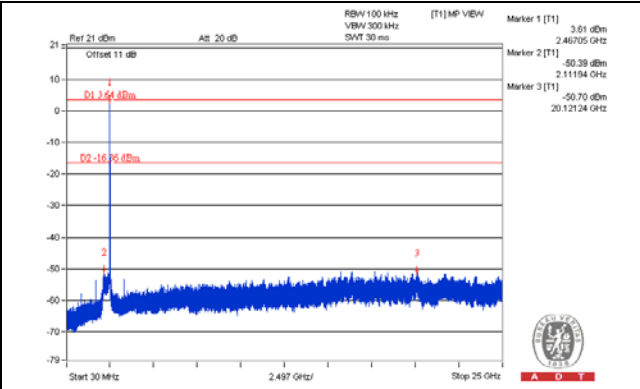
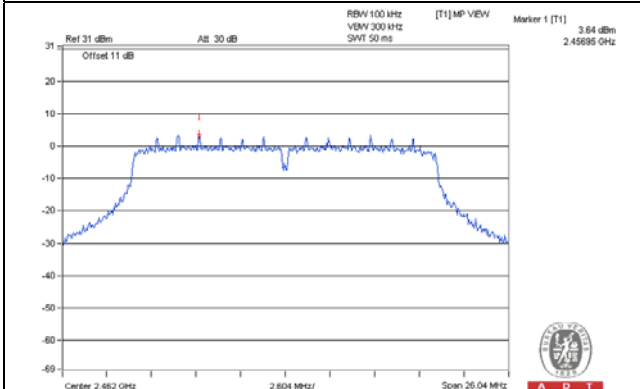

CH 1 Band edge

CH 11 Band edge

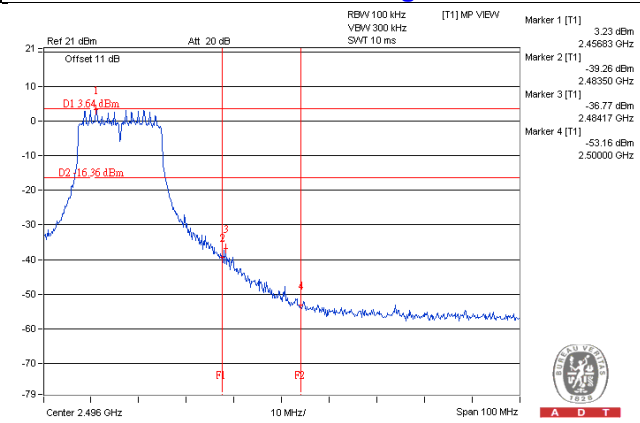
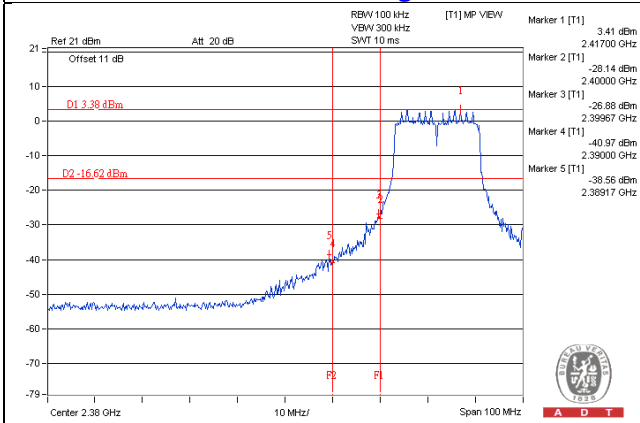

CHAIN 1

CH 1

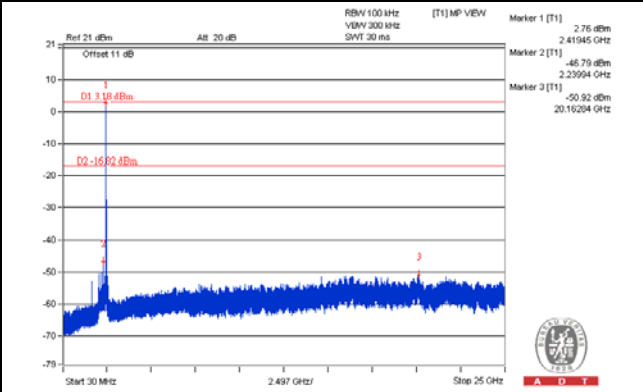
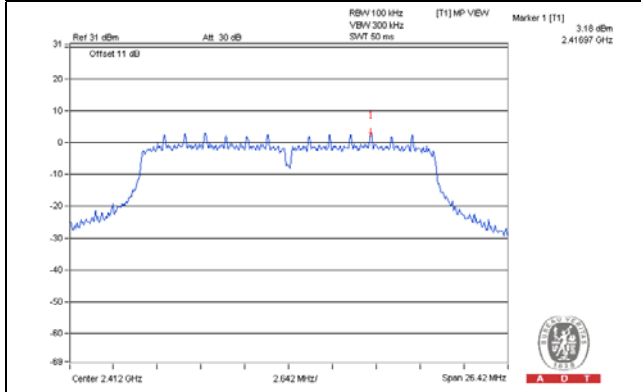

CH 6

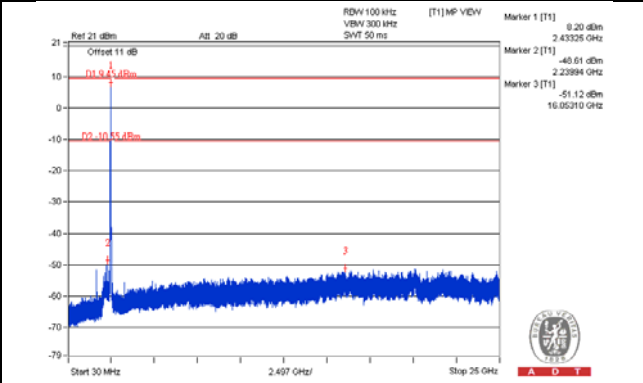
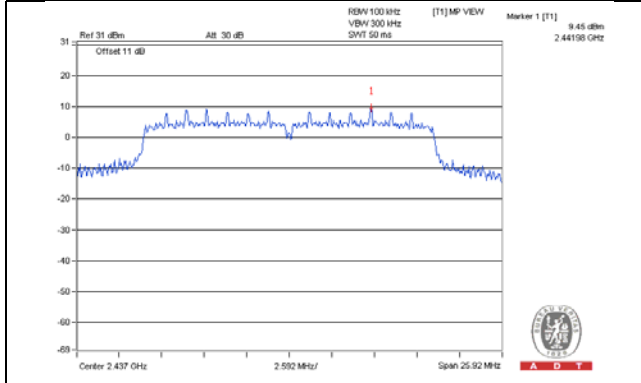

CH 11

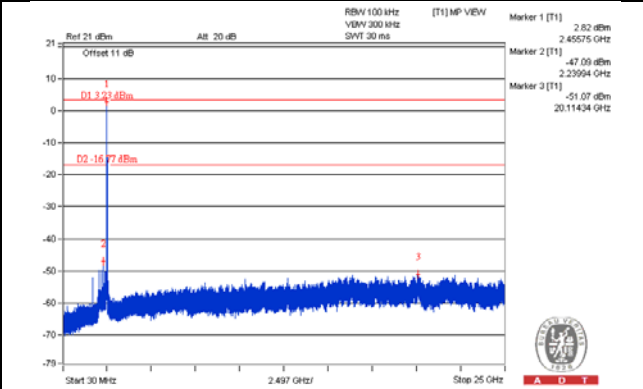
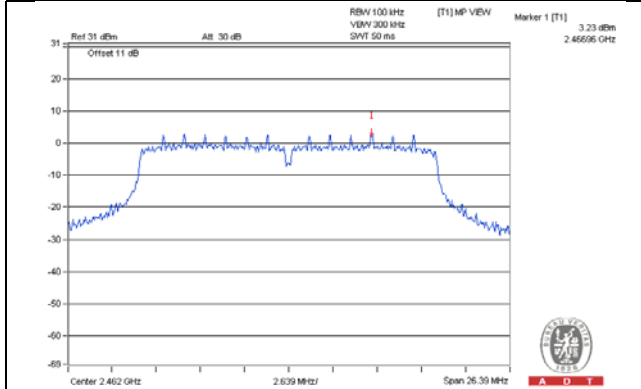

CH 1 Band edge

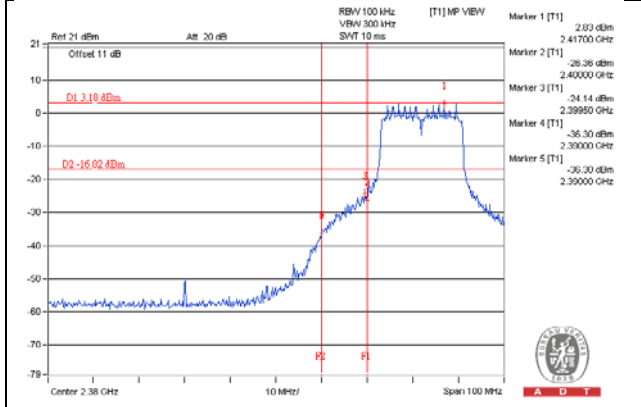

CH 11 Band edge

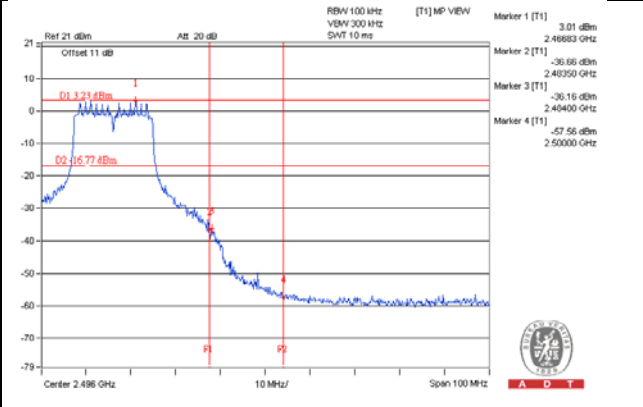

802.11n (HT40)  
CHAIN 0

CH 3

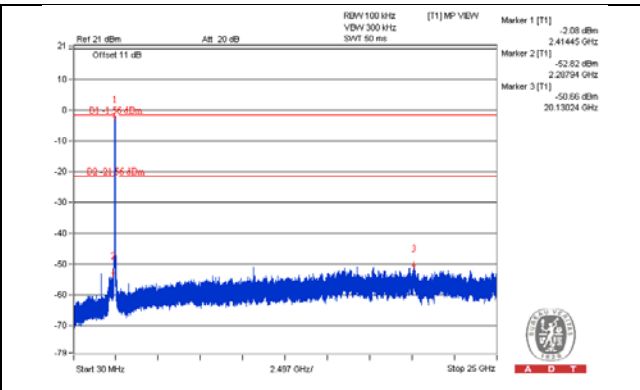
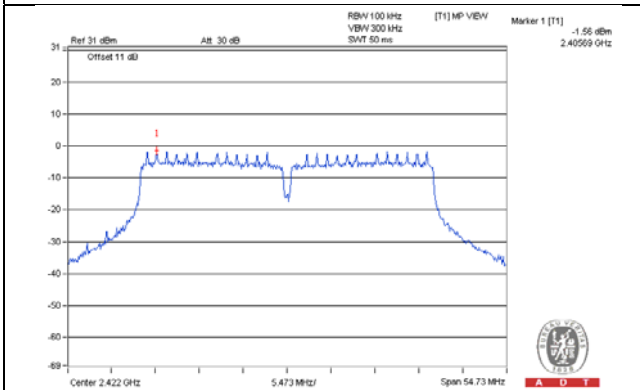

CH 6

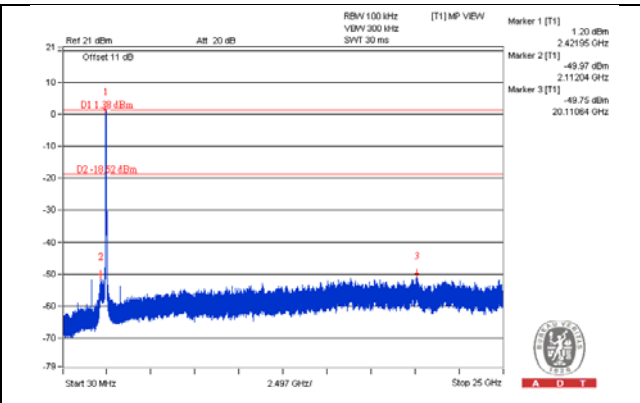
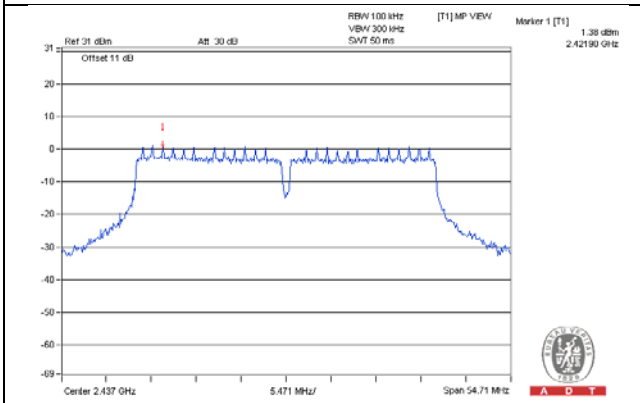

CH 9

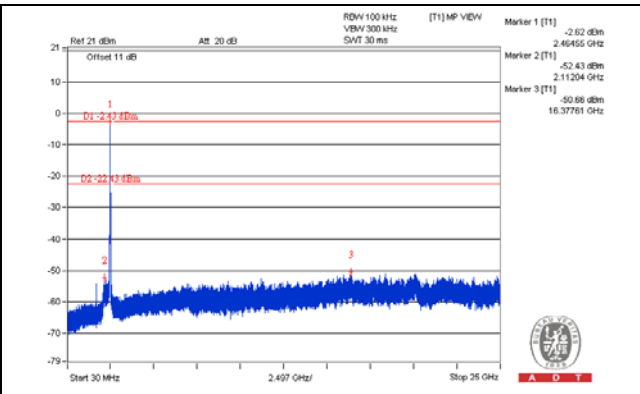
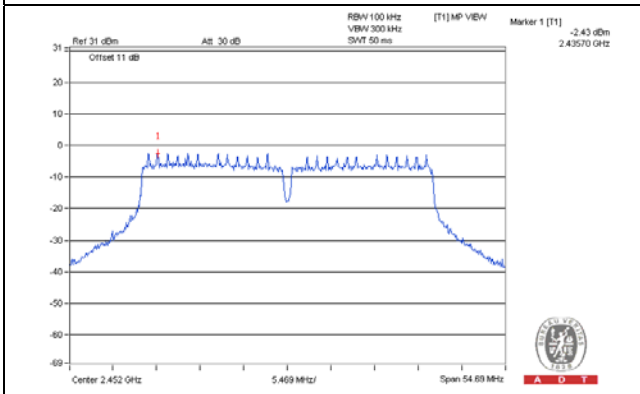

CH 3 Band edge

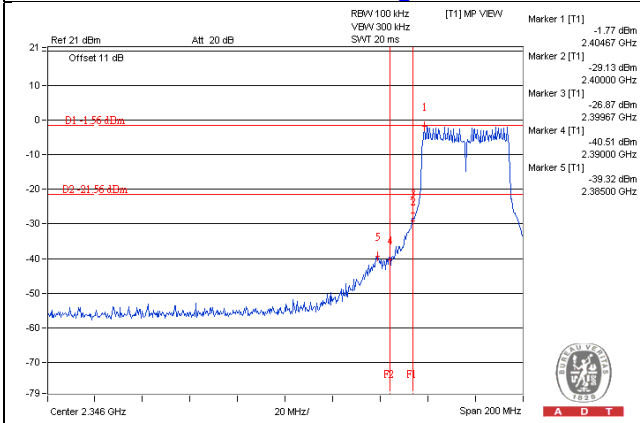

CH 9 Band edge

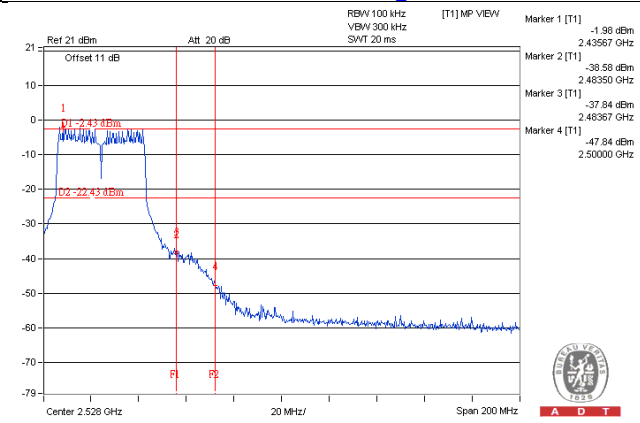

CHAIN 1

CH 3

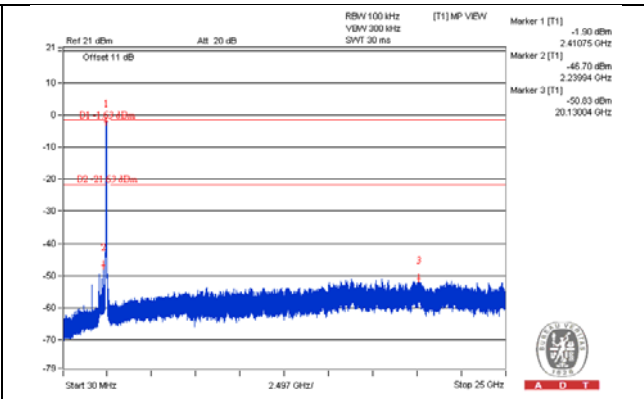
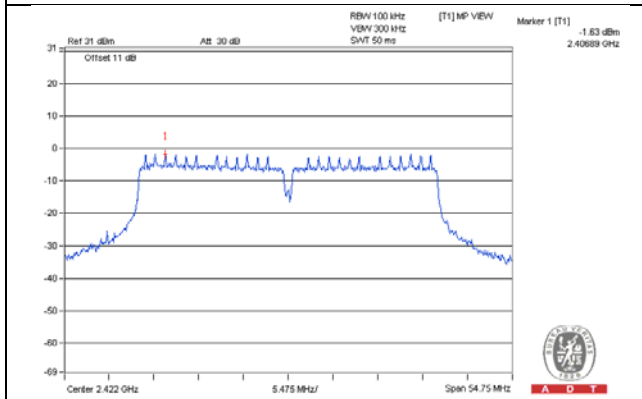

CH 6

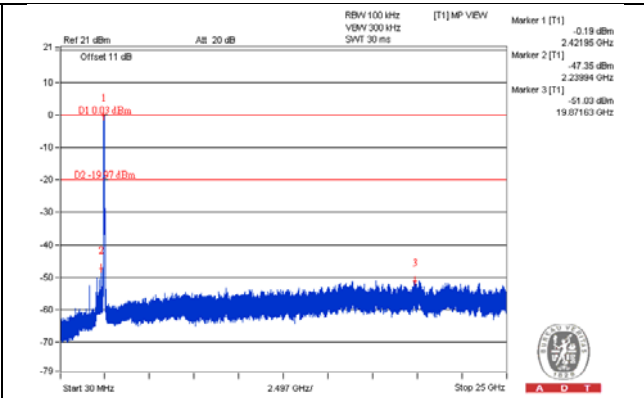
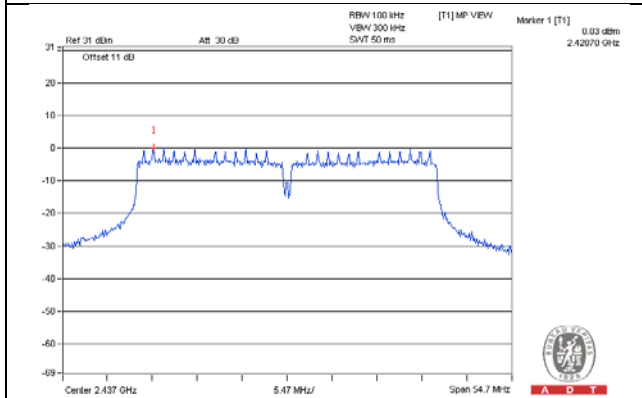

CH 9

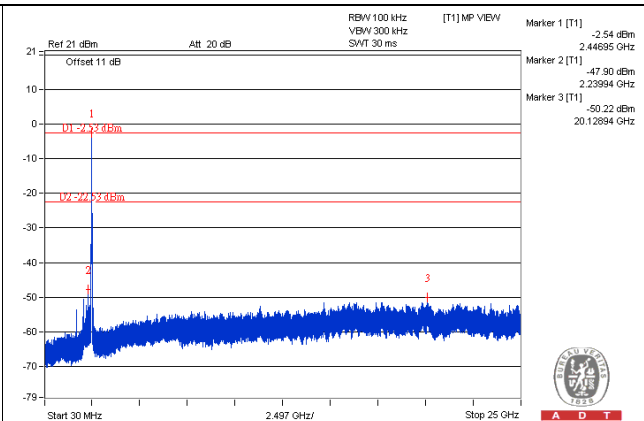
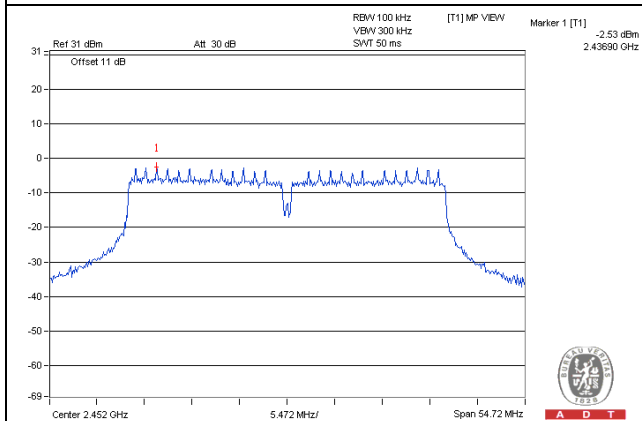

CH 3 Band edge

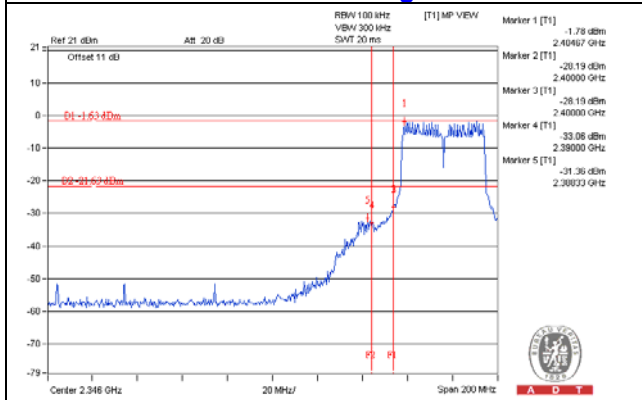

CH 9 Band edge

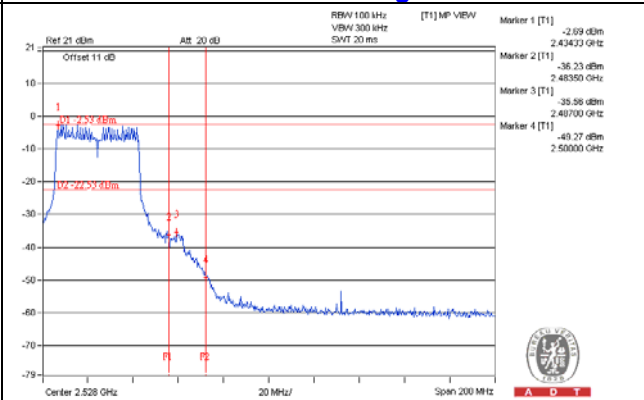



## 5 Pictures of Test Arrangements

Please refer to the attached file (Test Setup Photo).

## Appendix – Information on the Testing Laboratories

We, Bureau Veritas Consumer Products Services (H.K.) Ltd., Taoyuan Branch, were founded in 1988 to provide our best service in EMC, Radio, Telecom and Safety consultation. Our laboratories are accredited and approved according to ISO/IEC 17025.

If you have any comments, please feel free to contact us at the following:

**Linko EMC/RF Lab**

Tel: 886-2-26052180

Fax: 886-2-26051924

**Hsin Chu EMC/RF/Telecom Lab**

Tel: 886-3-5935343

Fax: 886-3-5935342

**Hwa Ya EMC/RF/Safety Lab**

Tel: 886-3-3183232

Fax: 886-3-3270892

**Email:** [service.adt@tw.bureauveritas.com](mailto:service.adt@tw.bureauveritas.com)

**Web Site:** [www.bureauveritas-adt.com](http://www.bureauveritas-adt.com)

The address and road map of all our labs can be found in our web site also.

--- END ---