

FCC Test Report

Report No.: RF190625C03-1

FCC ID: A8J-ENH500V3

Test Model: ENH500v3

Received Date: Jun. 25, 2019

Test Date: Sep. 18 ~ Sep. 23, 2019

Issued Date: Oct. 05, 2019

Applicant: EnGenius Technologies

Address: 1580 Scenic Avenue, Costa Mesa, CA92626

Issued By: Bureau Veritas Consumer Products Services (H.K.) Ltd., Taoyuan Branch
Lin Kou Laboratories

Lab Address: No. 47-2, 14th Ling, Chia Pau Vil., Lin Kou Dist., New Taipei City, Taiwan

Test Location: No. 19, Hwa Ya 2nd Rd., Wen Hwa Vil., Kwei Shan Dist., Taoyuan City
33383, TAIWAN

**FCC Registration /
Designation Number:** 788550 / TW0003



This report is for your exclusive use. Any copying or replication of this report to or for any other person or entity, or use of our name or trademark, is permitted only with our prior written permission. This report sets forth our findings solely with respect to the test samples identified herein. The results set forth in this report are not indicative or representative of the quality or characteristics of the lot from which a test sample was taken or any similar or identical product unless specifically and expressly noted. Our report includes all of the tests requested by you and the results thereof based upon the information that you provided to us. You have 60 days from date of issuance of this report to notify us of any material error or omission caused by our negligence, provided, however, that such notice shall be in writing and shall specifically address the issue you wish to raise. A failure to raise such issue within the prescribed time shall constitute your unqualified acceptance of the completeness of this report, the tests conducted and the correctness of the report contents. Unless specific mention, the uncertainty of measurement has been explicitly taken into account to declare the compliance or non-compliance to the specification. The report must not be used by the client to claim product certification, approval, or endorsement by TAF or any government agencies.

Table of Contents

Release Control Record	4
1 Certificate of Conformity	5
2 Summary of Test Results	6
2.1 Measurement Uncertainty.....	6
2.2 Modification Record.....	6
3 General Information	7
3.1 General Description of EUT.....	7
3.2 Description of Test Modes.....	9
3.2.1 Test Mode Applicability and Tested Channel Detail.....	10
3.3 Duty Cycle of Test Signal.....	12
3.4 Description of Support Units.....	13
3.4.1 Configuration of System under Test.....	13
3.5 General Description of Applied Standards.....	13
4 Test Types and Results	14
4.1 Radiated Emission and Bandedge Measurement.....	14
4.1.1 Limits of Radiated Emission and Bandedge Measurement.....	14
4.1.2 Test Instruments.....	15
4.1.3 Test Procedures.....	16
4.1.4 Deviation from Test Standard.....	16
4.1.5 Test Setup.....	17
4.1.6 EUT Operating Conditions.....	18
4.1.7 Test Results.....	19
4.2 Conducted Emission Measurement.....	39
4.2.1 Limits of Conducted Emission Measurement.....	39
4.2.2 Test Instruments.....	39
4.2.3 Test Procedures.....	40
4.2.4 Deviation from Test Standard.....	40
4.2.5 Test Setup.....	40
4.2.6 EUT Operating Conditions.....	40
4.2.7 Test Results.....	41
4.3 Transmit Power Measurement.....	43
4.3.1 Limits of Transmit Power Measurement.....	43
4.3.2 Test Setup.....	43
4.3.3 Test Instruments.....	43
4.3.4 Test Procedure.....	43
4.3.5 EUT Operating Conditions.....	43
4.3.6 Test Result.....	44
4.4 Occupied Bandwidth Measurement.....	48
4.4.1 Test Setup.....	48
4.4.2 Test Instruments.....	48
4.4.3 Test Procedure.....	48
4.4.4 Test Result.....	49
4.5 Peak Power Spectral Density Measurement.....	51
4.5.1 Limits of Peak Power Spectral Density Measurement.....	51
4.5.2 Test Setup.....	51
4.5.3 Test Instruments.....	51
4.5.4 Test Procedures.....	51
4.5.5 Deviation from Test Standard.....	52
4.5.6 EUT Operating Conditions.....	52
4.5.7 Test Results.....	53
4.6 Frequency Stability.....	58
4.6.1 Limits of Frequency Stability Measurement.....	58
4.6.2 Test Setup.....	58

4.6.3	Test Instruments	58
4.6.4	Test Procedure	58
4.6.5	Deviation from Test Standard	59
4.6.6	EUT Operating Condition	59
4.6.7	Test Results	59
4.7	6dB Bandwidth Measurement.....	60
4.7.1	Limits of 6dB Bandwidth Measurement.....	60
4.7.2	Test Setup.....	60
4.7.3	Test Instruments	60
4.7.4	Test Procedure	60
4.7.5	Deviation from Test Standard	60
4.7.6	EUT Operating Condition	60
4.7.7	Test Results	61
5	Pictures of Test Arrangements.....	63
	Annex A- Radiated Out of Band Emission (OOBE) Measurement (For U-NII-3 band).....	64
	Appendix – Information of the Testing Laboratories	67

Release Control Record

Issue No.	Description	Date Issued
RF190625C03-1	Original release	Oct. 05, 2019

1 Certificate of Conformity

Product: Outdoor Long Range Wireless Access Point

Brand: EnGenius

Test Model: ENH500v3

Sample Status: Engineering sample

Applicant: EnGenius Technologies

Test Date: Sep. 18 ~ Sep. 23, 2019

Standards: 47 CFR FCC Part 15, Subpart E (Section 15.407)
ANSI C63.10:2013

The above equipment has been tested by **Bureau Veritas Consumer Products Services (H.K.) Ltd., Taoyuan Branch**, and found compliance with the requirement of the above standards. The test record, data evaluation & Equipment Under Test (EUT) configurations represented herein are true and accurate accounts of the measurements of the sample's RF characteristics under the conditions specified in this report.

Prepared by : Celine Chou , **Date:** Oct. 05, 2019
Celine Chou / Senior Specialist

Approved by : Bruce Chen , **Date:** Oct. 05, 2019
Bruce Chen / Senior Project Engineer

2 Summary of Test Results

47 CFR FCC Part 15, Subpart E (Section 15.407)			
FCC Clause	Test Item	Result	Remarks
15.407(b)(6)	AC Power Conducted Emissions	Pass	Meet the requirement of limit. Minimum passing margin is -14.48dB at 0.15391MHz.
15.407(b)(1/2/3/4(i/ii)/6)	Radiated Emissions & Band Edge Measurement	Pass	Meet the requirement of limit. Minimum passing margin is -1.2dB at 5150.00MHz.
15.407(a)(1/2/3)	Max Average Transmit Power	Pass	Meet the requirement of limit.
---	Occupied Bandwidth Measurement	-	Reference only.
15.407(a)(1/2/3)	Peak Power Spectral Density	Pass	Meet the requirement of limit.
15.407(e)	6dB bandwidth	Pass	Meet the requirement of limit. (U-NII-3 Band only)
15.407(g)	Frequency Stability	Pass	Meet the requirement of limit.
15.203	Antenna Requirement	Pass	Antenna connector is Pin not a standard connector.

Note:

- Determining compliance based on the results of the compliance measurement, not taking into account measurement instrumentation uncertainty.
- For U-NII-3 band compliance with rule part 15.407(b)(4)(i), the OOB test plots were recorded in Annex A.

2.1 Measurement Uncertainty

Where relevant, the following measurement uncertainty levels have been estimated for tests performed on the EUT as specified in CISPR 16-4-2:

Measurement	Frequency	Expanded Uncertainty (k=2) (\pm)
Conducted Emissions at mains ports	150kHz ~ 30MHz	2.94 dB
Radiated Emissions up to 1 GHz	9kHz ~ 30MHz	3.04 dB
	30MHz ~ 200MHz	3.86 dB
	200MHz ~ 1000MHz	3.87 dB
Radiated Emissions above 1 GHz	1GHz ~ 18GHz	2.29 dB
	18GHz ~ 40GHz	2.29 dB

2.2 Modification Record

There were no modifications required for compliance.

3 General Information

3.1 General Description of EUT

Product	Outdoor Long Range Wireless Access Point
Brand	EnGenius
Test Model	ENH500v3
Sample Status	Engineering sample
Power Supply Rating	24Vdc from PoE
Modulation Type	256QAM, 64QAM, 16QAM, QPSK, BPSK
Modulation Technology	OFDM
Transfer Rate	802.11a: 54/48/36/24/18/12/9/6Mbps 802.11n: up to 300Mbps 802.11ac: up to 867Mbps
Operating Frequency	5180 ~ 5240MHz, 5745 ~ 5825MHz
Number of Channel	5180 ~ 5240MHz: 802.11a, 802.11n (HT20), 802.11ac (VHT20): 4 802.11n (HT40), 802.11ac (VHT40): 2 802.11ac (VHT80): 1 5745 ~ 5825MHz: 802.11a, 802.11n (HT20), 802.11ac (VHT20): 5 802.11n (HT40), 802.11ac (VHT40): 2 802.11ac (VHT80): 1
Output Power	CDD Mode: 5180 ~ 5240MHz: 122.005mW 5745 ~ 5825MHz: 152.865mW Beamforming Mode: 5180 ~ 5240MHz: 61.007mW 5745 ~ 5825MHz: 76.438mW
Antenna Type	Refer to note
Antenna Connector	Refer to note
Accessory Device	PoE
Cable Supplied	NA

Note:

1. The EUT incorporates a MIMO function. Physically, the EUT provides 2 completed transmitters and 2 receivers.

Modulation Mode	Beamforming Mode	TX Function
802.11a	Not Support	2TX
802.11n (HT20)	Support	2TX
802.11n (HT40)	Support	2TX
802.11ac (VHT20)	Support	2TX
802.11ac (VHT40)	Support	2TX
802.11ac (VHT80)	Support	2TX

* The modulation and bandwidth are similar for 802.11n mode for 20MHz/40MHz and 802.11ac mode for 20MHz/40MHz, therefore investigated worst case to representative mode in test report. (Final test mode refer section 3.2.1)

* For 802.11n and 802.11ac, CDD mode and Beamforming mode are presented in power output test item. For other test items, CDD mode is the worst case for final tests after pretesting.

2. The EUT with follow antennas gain is listed as table below.

Ant. No.	Antenna Type	Connector	Polarization	Gain(dBi)
				5.15-5.85GHz
1	Patch	Pin	Hor.	14.11
2			Ver.	13.36

* The EUT will install at outdoor area, the highest antenna gain from the horizon above 30 degrees as below, for more detail information please refer to antenna specification and user manual

Antenna No.	Antenna gain	Antenna install degree
1, 2	0.11 dBi	

Due to device can be configuration at different angle ,thus consider to above 30 degrees from the horizon the highest antenna gain are chosen from antenna specification exhibits from 0 to 60 degrees and 300 to 360 degrees for U-NII-1 band.

3. The EUT consumes power from the following PoE.

Brand	EnGenius
Model	EPA2406GR
Input Power	100-240Vac, 0.4A, 50-60Hz
Output Power	24Vdc, 0.6A PIN 4,5: 24Vdc PIN 7,8: RETURN
Power Line	0.55m non-shielded AC power cable without core

4. 2.4GHz & 5GHz technology can transmit at same time.
5. Spurious emission of the simultaneous operation (2.4GHz, 5GHz) has been evaluated and no non-compliance was found.

3.2 Description of Test Modes

For 5180 ~ 5240MHz:

4 channels are provided for 802.11a, 802.11n (HT20), 802.11ac (VHT20):

Channel	Frequency	Channel	Frequency
36	5180 MHz	44	5220 MHz
40	5200 MHz	48	5240 MHz

2 channels are provided for 802.11n (HT40), 802.11ac (VHT40):

Channel	Frequency	Channel	Frequency
38	5190 MHz	46	5230 MHz

1 channel is provided for 802.11ac (VHT80):

Channel	Frequency
42	5210MHz

For 5745 ~ 5825MHz:

5 channels are provided for 802.11a, 802.11n (HT20), 802.11ac (VHT20):

Channel	Frequency	Channel	Frequency
149	5745MHz	161	5805MHz
153	5765MHz	165	5825MHz
157	5785MHz		

2 channels are provided for 802.11n (HT40), 802.11ac (VHT40):

Channel	Frequency	Channel	Frequency
151	5755MHz	159	5795MHz

1 channel is provided for 802.11ac (VHT80):

Channel	Frequency
155	5775MHz

3.2.1 Test Mode Applicability and Tested Channel Detail

EUT Configure Mode	Applicable to				Description
	RE \geq 1G	RE<1G	PLC	APCM	
-	√	√	√	√	-

Where RE \geq 1G: Radiated Emission above 1GHz & Bandedge Measurement
 RE<1G: Radiated Emission below 1GHz
 PLC: Power Line Conducted Emission
 APCM: Antenna Port Conducted Measurement

Note: Radiated emission test (below 1GHz) and power line conducted emission test items chosen the worst maximum power.

Radiated Emission Test (Above 1GHz):

- Pre-Scan has been conducted to determine the worst-case mode from all possible combinations between available modulations, data rates and antenna ports (if EUT with antenna diversity architecture).
- Following channel(s) was (were) selected for the final test as listed below.

EUT Configure Mode	Mode	Frequency Band (MHz)	Available Channel	Tested Channel	Modulation Technology	Data Rate (Mbps)
-	802.11a	5180-5240	36 to 48	36, 40, 48	OFDM	6.0
	802.11n (HT20)		36 to 48	36, 40, 48	OFDM	6.5
	802.11n (HT40)		38 to 46	38, 46	OFDM	13.5
	802.11ac (VHT80)		42	42	OFDM	29.3
-	802.11a	5745-5825	149 to 165	149, 157, 165	OFDM	6.0
	802.11n (HT20)		149 to 165	149, 157, 165	OFDM	6.5
	802.11n (HT40)		151 to 159	151, 159	OFDM	13.5
	802.11ac (VHT80)		155	155	OFDM	29.3

Radiated Emission Test (Below 1GHz):

- Pre-Scan has been conducted to determine the worst-case mode from all possible combinations between available modulations, data rates and antenna ports (if EUT with antenna diversity architecture).
- Following channel(s) was (were) selected for the final test as listed below.

EUT Configure Mode	Mode	Frequency Band (MHz)	Available Channel	Tested Channel	Modulation Technology	Data Rate (Mbps)
-	802.11n (HT20)	5180-5240	36 to 48	165	OFDM	6.0
-	802.11n (HT20)	5745-5825	149 to 165		OFDM	6.0

Power Line Conducted Emission Test:

- Pre-Scan has been conducted to determine the worst-case mode from all possible combinations between available modulations, data rates and antenna ports (if EUT with antenna diversity architecture).
- Following channel(s) was (were) selected for the final test as listed below.

EUT Configure Mode	Mode	Frequency Band (MHz)	Available Channel	Tested Channel	Modulation Technology	Data Rate (Mbps)
-	802.11n (HT20)	5180-5240	36 to 48	165	OFDM	6.0
-	802.11n (HT20)	5745-5825	149 to 165		OFDM	6.0

Antenna Port Conducted Measurement:

- This item includes all test value of each mode, but only includes spectrum plot of worst value of each mode.
- Pre-Scan has been conducted to determine the worst-case mode from all possible combinations between available modulations, data rates and antenna ports (if EUT with antenna diversity architecture).
- Following channel(s) was (were) selected for the final test as listed below.

EUT Configure Mode	Mode	Frequency Band (MHz)	Available Channel	Tested Channel	Modulation Technology	Data Rate (Mbps)
-	802.11a	5180-5240	36 to 48	36, 40, 48	OFDM	6.0
	802.11n (HT20)		36 to 48	36, 40, 48	OFDM	6.5
	802.11n (HT40)		38 to 46	38, 46	OFDM	13.5
	802.11ac (VHT80)		42	42	OFDM	29.3
-	802.11a	5745-5825	149 to 165	149, 157, 165	OFDM	6.0
	802.11n (HT20)		149 to 165	149, 157, 165	OFDM	6.5
	802.11n (HT40)		151 to 159	151, 159	OFDM	13.5
	802.11ac (VHT80)		155	155	OFDM	29.3

Test Condition:

Applicable to	Environmental Conditions	Input Power	Tested by
RE_≥1G	23 deg. C, 67% RH	120Vac, 60Hz	Adair Peng
RE_{<}1G	23 deg. C, 67% RH	120Vac, 60Hz	Adair Peng
PLC	25 deg. C, 66% RH	120Vac, 60Hz	Titan Hsu
APCM	25 deg. C, 60% RH	120Vac, 60Hz	Ivan Tseng

3.3 Duty Cycle of Test Signal

Duty cycle of test signal is < 98%, duty factor is required.

802.11a: Duty cycle = 2.050/2.142 = 0.957, Duty factor = $10 \cdot \log(1/0.957) = 0.19$

802.11n (HT20): Duty cycle = 4.980/5.090 = 0.978, Duty factor = $10 \cdot \log(1/0.978) = 0.09$

802.11n (HT40): Duty cycle = 2.417/2.505 = 0.965, Duty factor = $10 \cdot \log(1/0.965) = 0.16$

802.11ac (VHT80): Duty cycle = 1.136/1.210 = 0.939, Duty factor = $10 \cdot \log(1/0.939) = 0.27$

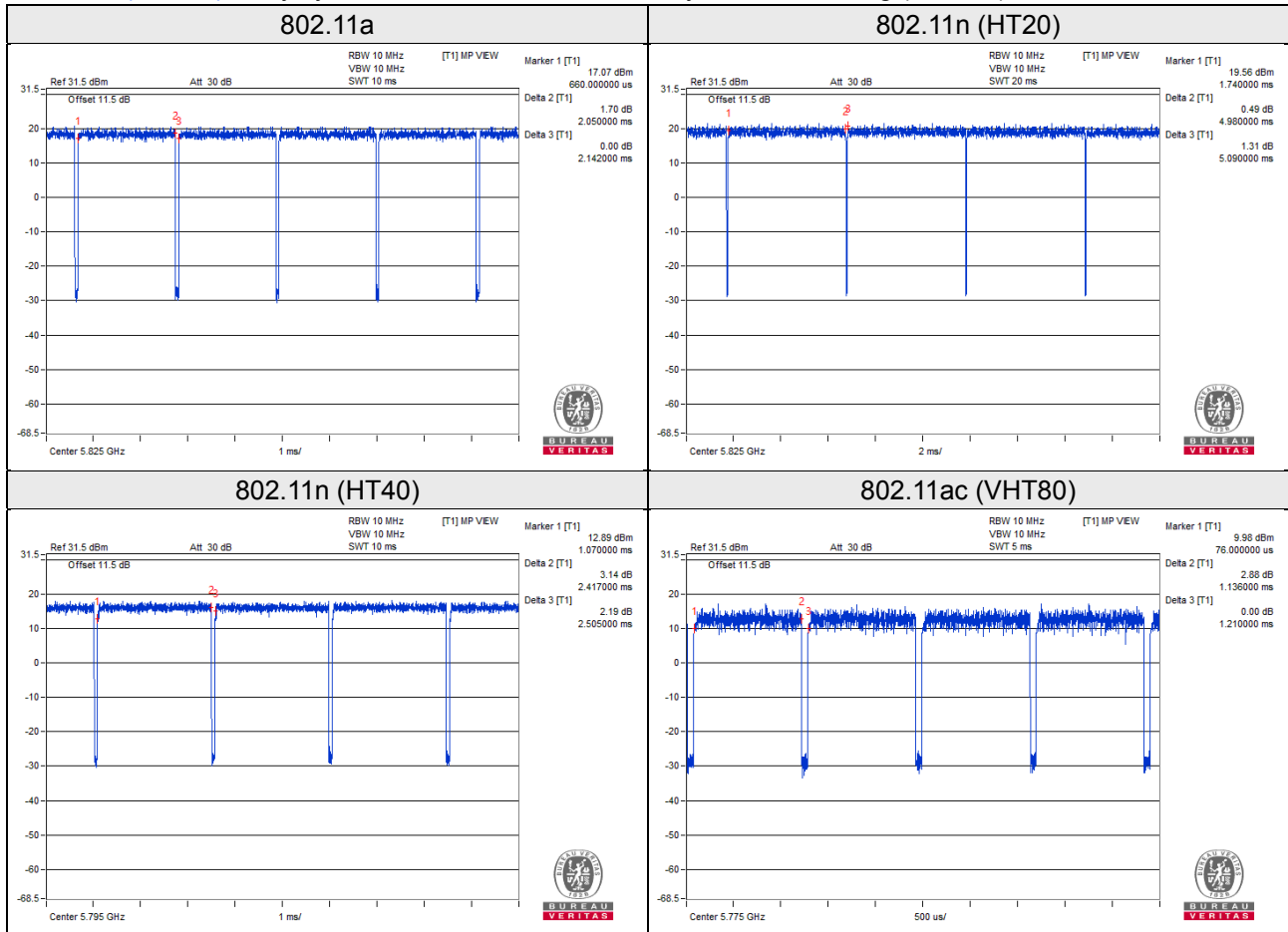

3.4 Description of Support Units

The EUT has been tested as an independent unit together with other necessary accessories or support units. The following support units or accessories were used to form a representative test configuration during the tests.

ID	Product	Brand	Model No.	Serial No.	FCC ID	Remarks
A.	Notebook	DELL	E5410	1HC2XM1	FCC DoC Approved	-
B.	Load	NA	NA	NA	NA	-

Note:

1. All power cords of the above support units are non-shielded (1.8m).
2. Item A acted as a communication partner to transfer data.

ID	Descriptions	Qty.	Length (m)	Shielding (Yes/No)	Cores (Qty.)	Remarks
1.	LAN	1	1.5	N	0	RJ45, Cat5e
2.	LAN	1	1.5	N	0	RJ45, Cat5e
3.	LAN	1	5	N	0	RJ45, Cat5e

3.4.1 Configuration of System under Test

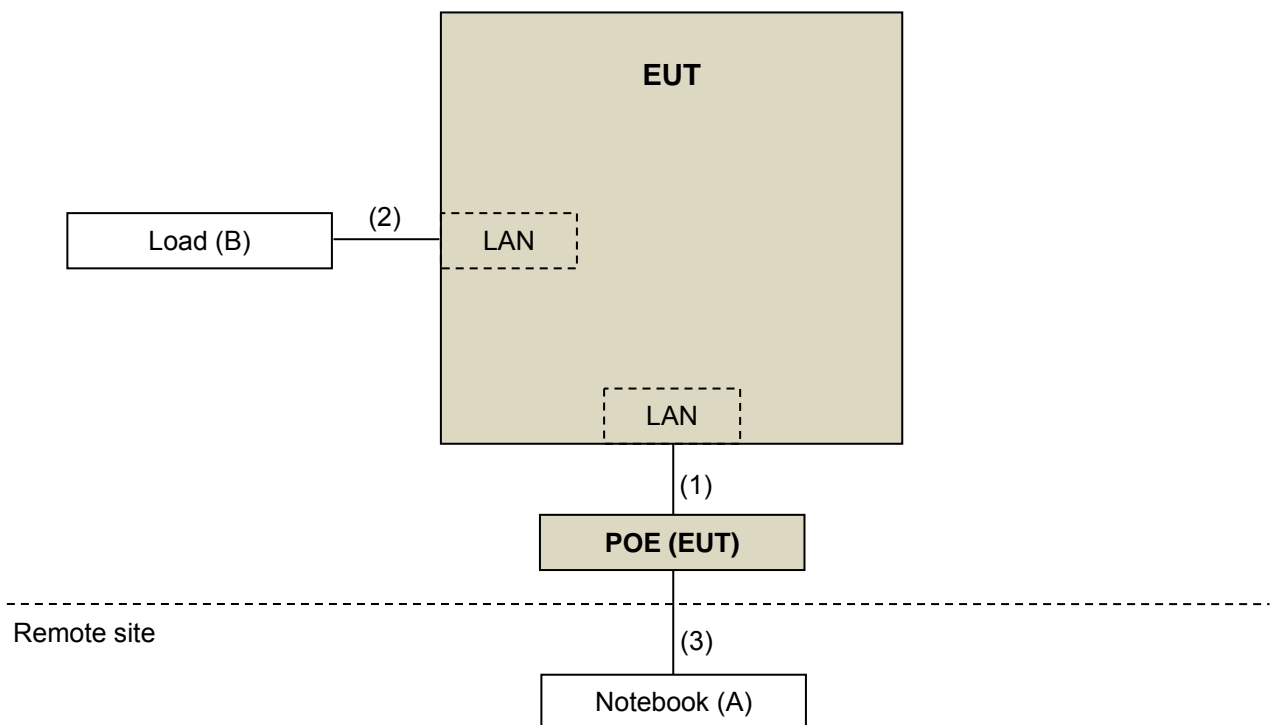

3.5 General Description of Applied Standards

The EUT is a RF Product. According to the specifications of the manufacturer, it must comply with the requirements of the following standards:

FCC Part 15, Subpart E (15.407)

KDB 789033 D02 General UNII Test Procedure New Rules v02r01

KDB 662911 D01 Multiple Transmitter Output v02r01

ANSI C63.10:2013

All test items have been performed and recorded as per the above standards.

4 Test Types and Results

4.1 Radiated Emission and Bandedge Measurement

4.1.1 Limits of Radiated Emission and Bandedge Measurement

Radiated emissions which fall in the restricted bands must comply with the radiated emission limits specified as below table.

Frequencies (MHz)	Field Strength (microvolts/meter)	Measurement Distance (meters)
0.009 ~ 0.490	2400/F(kHz)	300
0.490 ~ 1.705	24000/F(kHz)	30
1.705 ~ 30.0	30	30
30 ~ 88	100	3
88 ~ 216	150	3
216 ~ 960	200	3
Above 960	500	3

Note:

1. The lower limit shall apply at the transition frequencies.
2. Emission level (dBuV/m) = 20 log Emission level (uV/m).
3. For frequencies above 1000MHz, the field strength limits are based on average detector, however, the peak field strength of any emission shall not exceed the maximum permitted average limits, specified above by more than 20dB under any condition of modulation.

Limits of unwanted emission out of the restricted bands

Applicable To		Limit	
789033 D02 General UNII Test Procedure New Rules v02r01		Field Strength at 3m	
		PK: 74 (dBuV/m)	AV: 54 (dBuV/m)
Frequency Band	Applicable To	EIRP Limit	Equivalent Field Strength at 3m
5150~5250 MHz	15.407(b)(1)	PK: -27 (dBm/MHz)	PK: 68.2(dBuV/m)
5250~5350 MHz	15.407(b)(2)		
5470~5725 MHz	15.407(b)(3)		
5725~5850 MHz	<input checked="" type="checkbox"/> 15.407(b)(4)(i)	PK: -27 (dBm/MHz) ^{*1} PK: 10 (dBm/MHz) ^{*2} PK: 15.6 (dBm/MHz) ^{*3} PK: 27 (dBm/MHz) ^{*4}	PK: 68.2(dBuV/m) ^{*1} PK: 105.2 (dBuV/m) ^{*2} PK: 110.8(dBuV/m) ^{*3} PK: 122.2 (dBuV/m) ^{*4}
	<input type="checkbox"/> 15.407(b)(4)(ii)	Emission limits in section 15.247(d)	
^{*1} beyond 75 MHz or more above of the band edge.		^{*2} below the band edge increasing linearly to 10 dBm/MHz at 25 MHz above.	
^{*3} below the band edge increasing linearly to a level of 15.6 dBm/MHz at 5 MHz above.		^{*4} from 5 MHz above or below the band edge increasing linearly to a level of 27 dBm/MHz at the band edge.	

Note: The following formula is used to convert the equipment isotropic radiated power (eirp) to field strength:

$$E = \frac{1000000 \sqrt{30 P}}{3} \mu\text{V/m, where } P \text{ is the eirp (Watts).}$$

4.1.2 Test Instruments

Description & Manufacturer	Model No.	Serial No.	Cal. Date	Cal. Due
Test Receiver ROHDE & SCHWARZ	ESIB7	100187	May 30, 2019	May 29, 2020
BILOG Antenna SCHWARZBECK	VULB9168	9168-171	Nov. 22, 2018	Nov. 21, 2019
HORN Antenna SCHWARZBECK	9120D	209	Nov. 25, 2018	Nov. 24, 2019
HORN Antenna SCHWARZBECK	BBHA 9170	BBHA9170241	Nov. 25, 2018	Nov. 24, 2019
Loop Antenna TESEQ	HLA 6121	45745	Jul. 01, 2019	Jun. 30, 2020
Preamplifier Agilent (Below 1GHz)	8447D	2944A10738	Aug. 20, 2019	Aug. 19, 2020
Preamplifier Agilent (Above 1GHz)	8449B	3008A02465	Mar. 27, 2019	Mar. 26, 2020
RF Coaxial Cable WOKEN With 5dB PAD	8D-FB	Cable-CH3-01	Aug. 20, 2019	Aug. 19, 2020
RF signal cable HUBER+SUHNER	SUCOFLEX 104	Cable-CH3-03 (223653/4)	Aug. 20, 2019	Aug. 19, 2020
RF signal cable HUBER+SUHNER& EMCI	SUCOFLEX 104&EMC104-SM-S M-8000	Cable-CH3-03 (309224+170907)	Aug. 20, 2019	Aug. 19, 2020
Software BV ADT	ADT_Radiated_ V7.6.15.9.5	NA	NA	NA
Antenna Tower inn-co GmbH	MA 4000	013303	NA	NA
Antenna Tower Controller BV ADT	AT100	AT93021702	NA	NA
Turn Table BV ADT	TT100	TT93021702	NA	NA
Turn Table Controller BV ADT	SC100	SC93021702	NA	NA
Boresight Antenna Fixture	FBA-01	FBA-SIP01	NA	NA
Pre-amplifier (18GHz-40GHz) EMC	EMC184045B	980175	Nov. 14, 2018	Nov. 13, 2019
USB Wideband Power Sensor KEYSIGHT	U2021XA	MY55050005/MY5519 0004/MY55190007/MY 55210005	Jul. 15, 2019	Jul. 14, 2020

Note: 1. The calibration interval of the above test instruments is 12 months and the calibrations are traceable to NML/ROC and NIST/USA.

2. The test was performed in HwaYa Chamber 3.

4.1.3 Test Procedures

For Radiated emission below 30MHz

- a. The EUT was placed on the top of a rotating table 0.8 meters above the ground at a 3 meter chamber room. The table was rotated 360 degrees to determine the position of the highest radiation.
- b. The EUT was set 3 meters away from the interference-receiving antenna, which was mounted on the top of a variable-height antenna tower.
- c. Parallel, perpendicular, and ground-parallel orientations of the antenna are set to make the measurement.
- d. For each suspected emission, the EUT was arranged to its worst case and the rotatable table was turned from 0 degrees to 360 degrees to find the maximum reading.
- e. The test-receiver system was set to Quasi-Peak Detect Function and Specified Bandwidth with Maximum Hold Mode.

Note:

1. The resolution bandwidth and video bandwidth of test receiver/spectrum analyzer is 9kHz at frequency below 30MHz.

For Radiated emission above 30MHz

- a. The EUT was placed on the top of a rotating table 0.8 meters (for 30MHz ~ 1GHz) / 1.5 meters (for above 1GHz) above the ground at 3 meter chamber room for test. The table was rotated 360 degrees to determine the position of the highest radiation.
- b. The EUT was set 3 meters away from the interference-receiving antenna, which was mounted on the top of a variable-height antenna tower.
- c. The height of antenna is varied from one meter to four meters above the ground to determine the maximum value of the field strength. Both horizontal and vertical polarizations of the antenna are set to make the measurement.
- d. For each suspected emission, the EUT was arranged to its worst case and then the antenna was tuned to heights from 1 meter to 4 meters and the rotatable table was turned from 0 degrees to 360 degrees to find the maximum reading.
- e. The test-receiver system was set to quasi-peak detect function and specified bandwidth with maximum hold mode when the test frequency is below 1 GHz.
- f. The test-receiver system was set to peak and average detect function and specified bandwidth with maximum hold mode when the test frequency is above 1 GHz. If the peak reading value also meets average limit, measurement with the average detector is unnecessary.

Note:

1. The resolution bandwidth and video bandwidth of test receiver/spectrum analyzer is 120kHz for Quasi-peak detection (QP) at frequency below 1GHz.
2. The resolution bandwidth of test receiver/spectrum analyzer is 1 MHz and the video bandwidth is 3 MHz for Peak detection (PK) at frequency above 1GHz.
3. The resolution bandwidth of test receiver/spectrum analyzer is 1MHz and the video bandwidth is $\geq 1/T$ (Duty cycle < 98%) or 10Hz (Duty cycle $\geq 98\%$) for Average detection (AV) at frequency above 1GHz. (802.11a: RBW = 1MHz, VBW = 1kHz; 802.11n (HT20): RBW = 1MHz, VBW = 1kHz; 802.11n (HT40): RBW = 1MHz, VBW = 1kHz; 802.11ac (VHT80): RBW = 1MHz, VBW = 1kHz)
4. All modes of operation were investigated and the worst-case emissions are reported.

4.1.4 Deviation from Test Standard

No deviation.

4.1.5 Test Setup

For Radiated emission below 30MHz

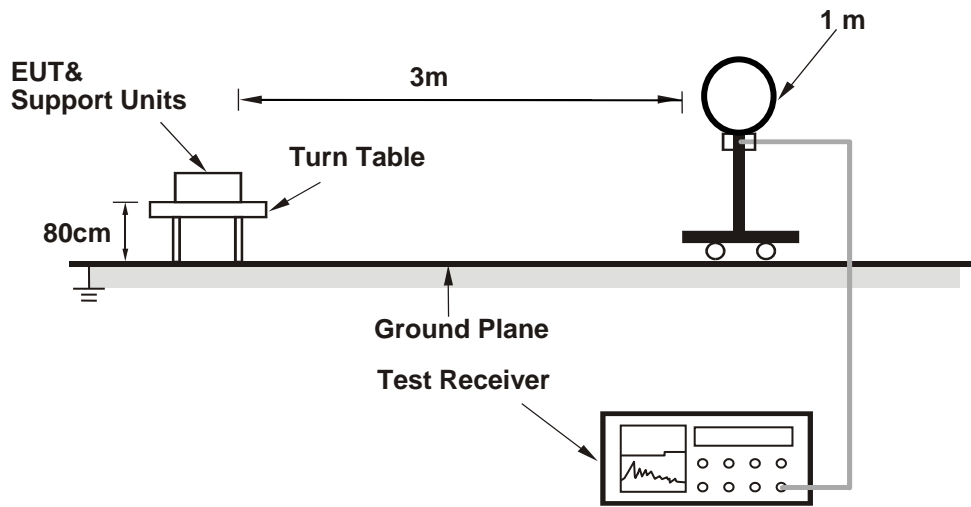

For Radiated emission 30MHz to 1GHz

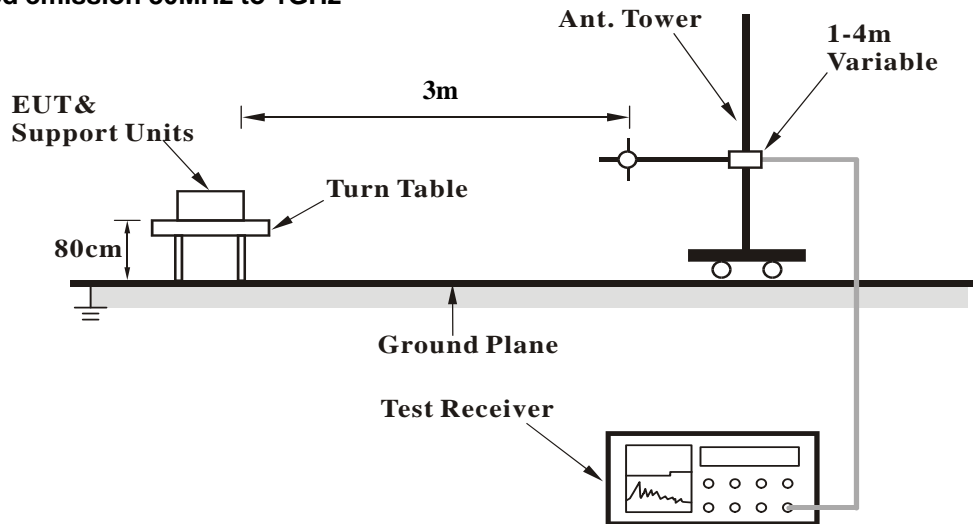

For Radiated emission above 1GHz

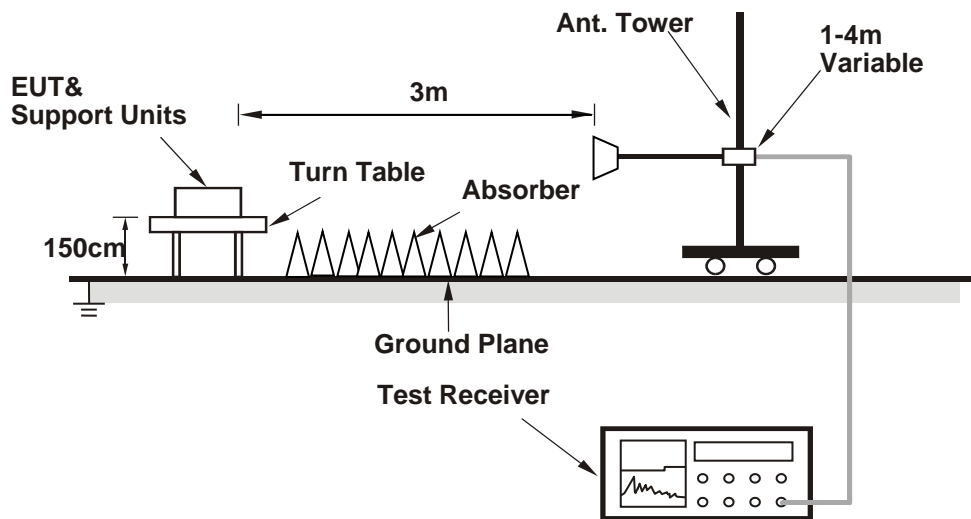

For the actual test configuration, please refer to the attached file (Test Setup Photo).

4.1.6 EUT Operating Conditions

- Placed the EUT on the testing table.
- Prepared a notebook to act as a communication partner and placed it outside of testing area.
- The communication partner connected with EUT via a RJ45 cable and ran a test program (provided by manufacturer) to enable EUT under transmission condition continuously at specific channel frequency.
- The communication partner sent data to EUT by command "PING".

4.1.7 Test Results

Above 1GHz data:

802.11a

CHANNEL	TX Channel 36	DETECTOR FUNCTION	Peak (PK) Average (AV)
FREQUENCY RANGE	1GHz ~ 40GHz		

ANTENNA POLARITY & TEST DISTANCE: HORIZONTAL AT 3 M								
NO.	FREQ. (MHz)	EMISSION LEVEL (dBuV/m)	LIMIT (dBuV/m)	MARGIN (dB)	ANTENNA HEIGHT (m)	TABLE ANGLE (Degree)	RAW VALUE (dBuV)	CORRECTION FACTOR (dB/m)
1	5150.00	61.5 PK	74.0	-12.5	1.47 H	349	57.3	4.2
2	5150.00	50.9 AV	54.0	-3.1	1.47 H	349	46.7	4.2
3	*5180.00	119.0 PK			1.44 H	346	79.6	39.4
4	*5180.00	107.8 AV			1.44 H	346	68.4	39.4
5	#10360.00	60.3 PK	68.2	-7.9	1.69 H	155	42.8	17.5
ANTENNA POLARITY & TEST DISTANCE: VERTICAL AT 3 M								
NO.	FREQ. (MHz)	EMISSION LEVEL (dBuV/m)	LIMIT (dBuV/m)	MARGIN (dB)	ANTENNA HEIGHT (m)	TABLE ANGLE (Degree)	RAW VALUE (dBuV)	CORRECTION FACTOR (dB/m)
1	5150.00	58.8 PK	74.0	-15.2	1.90 V	349	54.6	4.2
2	5150.00	45.9 AV	54.0	-8.1	1.90 V	349	41.7	4.2
3	*5180.00	119.0 PK			1.75 V	347	79.6	39.4
4	*5180.00	106.9 AV			1.75 V	347	67.5	39.4
5	#10360.00	60.4 PK	68.2	-7.8	1.38 V	182	42.9	17.5

Remarks:

1. Emission Level(dBuV/m) = Raw Value(dBuV) + Correction Factor(dB/m).
2. Correction Factor(dB/m) = Antenna Factor(dB/m) + Cable Factor(dB) – Pre-Amplifier Factor(dB).
3. Margin value = Emission Level – Limit value.
4. The other emission levels were very low against the limit.
5. " * ": Fundamental frequency.
6. " # ": The radiated frequency is out of the restricted band.

CHANNEL	TX Channel 40	DETECTOR FUNCTION	Peak (PK) Average (AV)
FREQUENCY RANGE	1GHz ~ 40GHz		

ANTENNA POLARITY & TEST DISTANCE: HORIZONTAL AT 3 M

NO.	FREQ. (MHz)	EMISSION LEVEL (dBuV/m)	LIMIT (dBuV/m)	MARGIN (dB)	ANTENNA HEIGHT (m)	TABLE ANGLE (Degree)	RAW VALUE (dBuV)	CORRECTION FACTOR (dB/m)
1	*5200.00	119.5 PK			1.57 H	345	80.2	39.3
2	*5200.00	108.0 AV			1.57 H	345	68.7	39.3
3	#10400.00	60.8 PK	68.2	-7.4	1.60 H	153	43.2	17.6

ANTENNA POLARITY & TEST DISTANCE: VERTICAL AT 3 M

NO.	FREQ. (MHz)	EMISSION LEVEL (dBuV/m)	LIMIT (dBuV/m)	MARGIN (dB)	ANTENNA HEIGHT (m)	TABLE ANGLE (Degree)	RAW VALUE (dBuV)	CORRECTION FACTOR (dB/m)
1	*5200.00	119.3 PK			1.69 V	343	80.0	39.3
2	*5200.00	107.4 AV			1.69 V	343	68.1	39.3
3	#10400.00	61.6 PK	68.2	-6.6	1.49 V	179	44.0	17.6

Remarks:

1. Emission Level(dBuV/m) = Raw Value(dBuV) + Correction Factor(dB/m).
2. Correction Factor(dB/m) = Antenna Factor(dB/m) + Cable Factor(dB) – Pre-Amplifier Factor(dB).
3. Margin value = Emission Level – Limit value.
4. The other emission levels were very low against the limit.
5. " * ": Fundamental frequency.
6. " # ": The radiated frequency is out of the restricted band.

CHANNEL	TX Channel 48	DETECTOR FUNCTION	Peak (PK) Average (AV)
FREQUENCY RANGE	1GHz ~ 40GHz		

ANTENNA POLARITY & TEST DISTANCE: HORIZONTAL AT 3 M

NO.	FREQ. (MHz)	EMISSION LEVEL (dBuV/m)	LIMIT (dBuV/m)	MARGIN (dB)	ANTENNA HEIGHT (m)	TABLE ANGLE (Degree)	RAW VALUE (dBuV)	CORRECTION FACTOR (dB/m)
1	*5240.00	119.2 PK			1.55 H	344	80.1	39.1
2	*5240.00	107.4 AV			1.55 H	344	68.3	39.1
3	5350.00	62.3 PK	74.0	-11.7	1.59 H	342	58.2	4.1
4	5350.00	49.1 AV	54.0	-4.9	1.59 H	342	45.0	4.1
5	#10480.00	62.3 PK	68.2	-5.9	1.48 H	155	43.9	18.4

ANTENNA POLARITY & TEST DISTANCE: VERTICAL AT 3 M

NO.	FREQ. (MHz)	EMISSION LEVEL (dBuV/m)	LIMIT (dBuV/m)	MARGIN (dB)	ANTENNA HEIGHT (m)	TABLE ANGLE (Degree)	RAW VALUE (dBuV)	CORRECTION FACTOR (dB/m)
1	*5240.00	118.9 PK			1.66 V	344	79.8	39.1
2	*5240.00	106.9 AV			1.66 V	344	67.8	39.1
3	5350.00	60.7 PK	74.0	-13.3	1.78 V	349	56.6	4.1
4	5350.00	47.6 AV	54.0	-6.4	1.78 V	349	43.5	4.1
5	#10480.00	62.9 PK	68.2	-5.3	1.41 V	169	44.5	18.4

Remarks:

1. Emission Level(dBuV/m) = Raw Value(dBuV) + Correction Factor(dB/m).
2. Correction Factor(dB/m) = Antenna Factor(dB/m) + Cable Factor(dB) – Pre-Amplifier Factor(dB).
3. Margin value = Emission Level – Limit value.
4. The other emission levels were very low against the limit.
5. " * " : Fundamental frequency.
6. " # " : The radiated frequency is out of the restricted band.

CHANNEL	TX Channel 149	DETECTOR FUNCTION	Peak (PK) Average (AV)
FREQUENCY RANGE	1GHz ~ 40GHz		

ANTENNA POLARITY & TEST DISTANCE: HORIZONTAL AT 3 M

NO.	FREQ. (MHz)	EMISSION LEVEL (dBuV/m)	LIMIT (dBuV/m)	MARGIN (dB)	ANTENNA HEIGHT (m)	TABLE ANGLE (Degree)	RAW VALUE (dBuV)	CORRECTION FACTOR (dB/m)
1	#5607.20	62.0 PK	68.2	-6.2	1.51 H	346	57.5	4.5
2	*5745.00	120.3 PK			1.51 H	346	80.2	40.1
3	*5745.00	109.5 AV			1.51 H	346	69.4	40.1
4	#5933.60	59.0 PK	68.2	-9.2	1.51 H	346	53.6	5.4
5	11490.00	59.9 PK	74.0	-14.1	1.96 H	143	40.6	19.3
6	11490.00	47.0 AV	54.0	-7.0	1.96 H	143	27.7	19.3

ANTENNA POLARITY & TEST DISTANCE: VERTICAL AT 3 M

NO.	FREQ. (MHz)	EMISSION LEVEL (dBuV/m)	LIMIT (dBuV/m)	MARGIN (dB)	ANTENNA HEIGHT (m)	TABLE ANGLE (Degree)	RAW VALUE (dBuV)	CORRECTION FACTOR (dB/m)
1	#5624.80	57.6 PK	68.2	-10.6	1.69 V	346	53.2	4.4
2	*5745.00	118.1 PK			1.69 V	346	78.0	40.1
3	*5745.00	106.5 AV			1.69 V	346	66.4	40.1
4	#5941.60	57.6 PK	68.2	-10.6	1.69 V	346	52.2	5.4
5	11490.00	59.3 PK	74.0	-14.7	1.52 V	177	40.0	19.3
6	11490.00	46.5 AV	54.0	-7.5	1.52 V	177	27.2	19.3

Remarks:

1. Emission Level(dBuV/m) = Raw Value(dBuV) + Correction Factor(dB/m).
2. Correction Factor(dB/m) = Antenna Factor(dB/m) + Cable Factor(dB) – Pre-Amplifier Factor(dB).
3. Margin value = Emission Level – Limit value.
4. The other emission levels were very low against the limit.
5. " * " : Fundamental frequency.
6. " # " : The radiated frequency is out of the restricted band.

CHANNEL	TX Channel 157	DETECTOR FUNCTION	Peak (PK) Average (AV)
FREQUENCY RANGE	1GHz ~ 40GHz		

ANTENNA POLARITY & TEST DISTANCE: HORIZONTAL AT 3 M

NO.	FREQ. (MHz)	EMISSION LEVEL (dBuV/m)	LIMIT (dBuV/m)	MARGIN (dB)	ANTENNA HEIGHT (m)	TABLE ANGLE (Degree)	RAW VALUE (dBuV)	CORRECTION FACTOR (dB/m)
1	#5604.80	61.7 PK	68.2	-6.5	1.57 H	348	57.2	4.5
2	*5785.00	120.7 PK			1.57 H	348	80.4	40.3
3	*5785.00	109.7 AV			1.57 H	348	69.4	40.3
4	#5934.40	58.1 PK	68.2	-10.1	1.57 H	348	52.7	5.4
5	11570.00	60.1 PK	74.0	-13.9	1.85 H	153	41.1	19.0
6	11570.00	46.9 AV	54.0	-7.1	1.85 H	153	27.9	19.0

ANTENNA POLARITY & TEST DISTANCE: VERTICAL AT 3 M

NO.	FREQ. (MHz)	EMISSION LEVEL (dBuV/m)	LIMIT (dBuV/m)	MARGIN (dB)	ANTENNA HEIGHT (m)	TABLE ANGLE (Degree)	RAW VALUE (dBuV)	CORRECTION FACTOR (dB/m)
1	#5624.00	58.1 PK	68.2	-10.1	1.71 V	350	53.7	4.4
2	*5785.00	119.5 PK			1.71 V	350	79.2	40.3
3	*5785.00	107.6 AV			1.71 V	350	67.3	40.3
4	#5928.80	57.7 PK	68.2	-10.5	1.71 V	350	52.3	5.4
5	11570.00	59.7 PK	74.0	-14.3	1.57 V	179	40.7	19.0
6	11570.00	46.5 AV	54.0	-7.5	1.57 V	179	27.5	19.0

Remarks:

1. Emission Level(dBuV/m) = Raw Value(dBuV) + Correction Factor(dB/m).
2. Correction Factor(dB/m) = Antenna Factor(dB/m) + Cable Factor(dB) – Pre-Amplifier Factor(dB).
3. Margin value = Emission Level – Limit value.
4. The other emission levels were very low against the limit.
5. " * " : Fundamental frequency.
6. " # " : The radiated frequency is out of the restricted band.

CHANNEL	TX Channel 165	DETECTOR FUNCTION	Peak (PK) Average (AV)
FREQUENCY RANGE	1GHz ~ 40GHz		

ANTENNA POLARITY & TEST DISTANCE: HORIZONTAL AT 3 M

NO.	FREQ. (MHz)	EMISSION LEVEL (dBuV/m)	LIMIT (dBuV/m)	MARGIN (dB)	ANTENNA HEIGHT (m)	TABLE ANGLE (Degree)	RAW VALUE (dBuV)	CORRECTION FACTOR (dB/m)
1	#5601.60	63.0 PK	68.2	-5.2	1.58 H	345	58.5	4.5
2	*5825.00	120.3 PK			1.58 H	345	79.9	40.4
3	*5825.00	109.4 AV			1.58 H	345	69.0	40.4
4	#5995.20	58.8 PK	68.2	-9.4	1.58 H	345	53.3	5.5
5	11650.00	60.2 PK	74.0	-13.8	1.91 H	149	41.3	18.9
6	11650.00	46.9 AV	54.0	-7.1	1.91 H	149	28.0	18.9

ANTENNA POLARITY & TEST DISTANCE: VERTICAL AT 3 M

NO.	FREQ. (MHz)	EMISSION LEVEL (dBuV/m)	LIMIT (dBuV/m)	MARGIN (dB)	ANTENNA HEIGHT (m)	TABLE ANGLE (Degree)	RAW VALUE (dBuV)	CORRECTION FACTOR (dB/m)
1	#5607.20	57.5 PK	68.2	-10.7	1.65 V	344	53.0	4.5
2	*5825.00	120.2 PK			1.65 V	344	79.8	40.4
3	*5825.00	108.6 AV			1.65 V	344	68.2	40.4
4	#5954.40	57.7 PK	68.2	-10.5	1.65 V	344	52.3	5.4
5	11650.00	59.7 PK	74.0	-14.3	1.57 V	173	40.8	18.9
6	11650.00	46.6 AV	54.0	-7.4	1.57 V	173	27.7	18.9

Remarks:

1. Emission Level(dBuV/m) = Raw Value(dBuV) + Correction Factor(dB/m).
2. Correction Factor(dB/m) = Antenna Factor(dB/m) + Cable Factor(dB) – Pre-Amplifier Factor(dB).
3. Margin value = Emission Level – Limit value.
4. The other emission levels were very low against the limit.
5. " * " : Fundamental frequency.
6. " # " : The radiated frequency is out of the restricted band.

802.11n (HT20)

CHANNEL	TX Channel 36	DETECTOR FUNCTION	Peak (PK) Average (AV)
FREQUENCY RANGE	1GHz ~ 40GHz		

ANTENNA POLARITY & TEST DISTANCE: HORIZONTAL AT 3 M

NO.	FREQ. (MHz)	EMISSION LEVEL (dBuV/m)	LIMIT (dBuV/m)	MARGIN (dB)	ANTENNA HEIGHT (m)	TABLE ANGLE (Degree)	RAW VALUE (dBuV)	CORRECTION FACTOR (dB/m)
1	5150.00	61.8 PK	74.0	-12.2	1.56 H	341	57.6	4.2
2	5150.00	50.7 AV	54.0	-3.3	1.56 H	341	46.5	4.2
3	*5180.00	119.2 PK			1.47 H	345	79.8	39.4
4	*5180.00	108.2 AV			1.47 H	345	68.8	39.4
5	#10360.00	61.1 PK	68.2	-7.1	1.55 H	153	43.6	17.5

ANTENNA POLARITY & TEST DISTANCE: VERTICAL AT 3 M

NO.	FREQ. (MHz)	EMISSION LEVEL (dBuV/m)	LIMIT (dBuV/m)	MARGIN (dB)	ANTENNA HEIGHT (m)	TABLE ANGLE (Degree)	RAW VALUE (dBuV)	CORRECTION FACTOR (dB/m)
1	5150.00	59.2 PK	74.0	-14.8	1.74 V	353	55.0	4.2
2	5150.00	46.1 AV	54.0	-7.9	1.74 V	353	41.9	4.2
3	*5180.00	118.9 PK			1.69 V	347	79.5	39.4
4	*5180.00	107.9 AV			1.69 V	347	68.5	39.4
5	#10360.00	61.5 PK	68.2	-6.7	1.49 V	172	44.0	17.5

Remarks:

1. Emission Level(dBuV/m) = Raw Value(dBuV) + Correction Factor(dB/m).
2. Correction Factor(dB/m) = Antenna Factor(dB/m) + Cable Factor(dB) – Pre-Amplifier Factor(dB).
3. Margin value = Emission Level – Limit value.
4. The other emission levels were very low against the limit.
5. " * ": Fundamental frequency.
6. " # ": The radiated frequency is out of the restricted band.

CHANNEL	TX Channel 40	DETECTOR FUNCTION	Peak (PK) Average (AV)
FREQUENCY RANGE	1GHz ~ 40GHz		

ANTENNA POLARITY & TEST DISTANCE: HORIZONTAL AT 3 M

NO.	FREQ. (MHz)	EMISSION LEVEL (dBuV/m)	LIMIT (dBuV/m)	MARGIN (dB)	ANTENNA HEIGHT (m)	TABLE ANGLE (Degree)	RAW VALUE (dBuV)	CORRECTION FACTOR (dB/m)
1	*5200.00	118.5 PK			1.54 H	346	79.2	39.3
2	*5200.00	107.7 AV			1.54 H	346	68.4	39.3
3	#10400.00	60.8 PK	68.2	-7.4	1.48 H	151	43.2	17.6

ANTENNA POLARITY & TEST DISTANCE: VERTICAL AT 3 M

NO.	FREQ. (MHz)	EMISSION LEVEL (dBuV/m)	LIMIT (dBuV/m)	MARGIN (dB)	ANTENNA HEIGHT (m)	TABLE ANGLE (Degree)	RAW VALUE (dBuV)	CORRECTION FACTOR (dB/m)
1	*5200.00	118.1 PK			1.74 V	346	78.8	39.3
2	*5200.00	107.1 AV			1.74 V	346	67.8	39.3
3	#10400.00	61.5 PK	68.2	-6.7	1.51 V	179	43.9	17.6

Remarks:

1. Emission Level(dBuV/m) = Raw Value(dBuV) + Correction Factor(dB/m).
2. Correction Factor(dB/m) = Antenna Factor(dB/m) + Cable Factor(dB) – Pre-Amplifier Factor(dB).
3. Margin value = Emission Level – Limit value.
4. The other emission levels were very low against the limit.
5. " * ": Fundamental frequency.
6. " # ": The radiated frequency is out of the restricted band.

CHANNEL	TX Channel 48	DETECTOR FUNCTION	Peak (PK) Average (AV)
FREQUENCY RANGE	1GHz ~ 40GHz		

ANTENNA POLARITY & TEST DISTANCE: HORIZONTAL AT 3 M

NO.	FREQ. (MHz)	EMISSION LEVEL (dBuV/m)	LIMIT (dBuV/m)	MARGIN (dB)	ANTENNA HEIGHT (m)	TABLE ANGLE (Degree)	RAW VALUE (dBuV)	CORRECTION FACTOR (dB/m)
1	*5240.00	117.2 PK			1.60 H	344	78.1	39.1
2	*5240.00	106.4 AV			1.60 H	344	67.3	39.1
3	5350.00	62.3 PK	74.0	-11.7	1.54 H	350	58.2	4.1
4	5350.00	48.9 AV	54.0	-5.1	1.54 H	350	44.8	4.1
5	#10480.00	61.8 PK	68.2	-6.4	1.53 H	152	43.4	18.4

ANTENNA POLARITY & TEST DISTANCE: VERTICAL AT 3 M

NO.	FREQ. (MHz)	EMISSION LEVEL (dBuV/m)	LIMIT (dBuV/m)	MARGIN (dB)	ANTENNA HEIGHT (m)	TABLE ANGLE (Degree)	RAW VALUE (dBuV)	CORRECTION FACTOR (dB/m)
1	*5240.00	116.9 PK			1.71 V	344	77.8	39.1
2	*5240.00	105.8 AV			1.71 V	344	66.7	39.1
3	5350.00	60.7 PK	74.0	-13.3	1.66 V	339	56.6	4.1
4	5350.00	47.3 AV	54.0	-6.7	1.66 V	339	43.2	4.1
5	#10480.00	62.3 PK	68.2	-5.9	1.41 V	180	43.9	18.4

Remarks:

1. Emission Level(dBuV/m) = Raw Value(dBuV) + Correction Factor(dB/m).
2. Correction Factor(dB/m) = Antenna Factor(dB/m) + Cable Factor(dB) – Pre-Amplifier Factor(dB).
3. Margin value = Emission Level – Limit value.
4. The other emission levels were very low against the limit.
5. " * " : Fundamental frequency.
6. " # " : The radiated frequency is out of the restricted band.

CHANNEL	TX Channel 149	DETECTOR FUNCTION	Peak (PK) Average (AV)
FREQUENCY RANGE	1GHz ~ 40GHz		

ANTENNA POLARITY & TEST DISTANCE: HORIZONTAL AT 3 M

NO.	FREQ. (MHz)	EMISSION LEVEL (dBuV/m)	LIMIT (dBuV/m)	MARGIN (dB)	ANTENNA HEIGHT (m)	TABLE ANGLE (Degree)	RAW VALUE (dBuV)	CORRECTION FACTOR (dB/m)
1	#5600.80	61.8 PK	68.2	-6.4	1.50 H	346	57.3	4.5
2	*5745.00	120.2 PK			1.50 H	346	80.1	40.1
3	*5745.00	109.1 AV			1.50 H	346	69.0	40.1
4	#5948.00	58.1 PK	68.2	-10.1	1.50 H	346	52.7	5.4
5	11490.00	60.1 PK	74.0	-13.9	1.88 H	149	40.8	19.3
6	11490.00	47.3 AV	54.0	-6.7	1.88 H	149	28.0	19.3

ANTENNA POLARITY & TEST DISTANCE: VERTICAL AT 3 M

NO.	FREQ. (MHz)	EMISSION LEVEL (dBuV/m)	LIMIT (dBuV/m)	MARGIN (dB)	ANTENNA HEIGHT (m)	TABLE ANGLE (Degree)	RAW VALUE (dBuV)	CORRECTION FACTOR (dB/m)
1	#5608.00	57.6 PK	68.2	-10.6	1.66 V	345	53.1	4.5
2	*5745.00	118.4 PK			1.66 V	345	78.3	40.1
3	*5745.00	106.6 AV			1.66 V	345	66.5	40.1
4	#5948.00	57.9 PK	68.2	-10.3	1.66 V	345	52.5	5.4
5	11490.00	59.8 PK	74.0	-14.2	1.53 V	179	40.5	19.3
6	11490.00	47.0 AV	54.0	-7.0	1.53 V	179	27.7	19.3

Remarks:

1. Emission Level(dBuV/m) = Raw Value(dBuV) + Correction Factor(dB/m).
2. Correction Factor(dB/m) = Antenna Factor(dB/m) + Cable Factor(dB) – Pre-Amplifier Factor(dB).
3. Margin value = Emission Level – Limit value.
4. The other emission levels were very low against the limit.
5. " * " : Fundamental frequency.
6. " # " : The radiated frequency is out of the restricted band.

CHANNEL	TX Channel 157	DETECTOR FUNCTION	Peak (PK) Average (AV)
FREQUENCY RANGE	1GHz ~ 40GHz		

ANTENNA POLARITY & TEST DISTANCE: HORIZONTAL AT 3 M

NO.	FREQ. (MHz)	EMISSION LEVEL (dBuV/m)	LIMIT (dBuV/m)	MARGIN (dB)	ANTENNA HEIGHT (m)	TABLE ANGLE (Degree)	RAW VALUE (dBuV)	CORRECTION FACTOR (dB/m)
1	#5602.40	61.9 PK	68.2	-6.3	1.53 H	348	57.4	4.5
2	*5785.00	120.5 PK			1.53 H	348	80.2	40.3
3	*5785.00	109.4 AV			1.53 H	348	69.1	40.3
4	#5976.00	58.5 PK	68.2	-9.7	1.53 H	348	53.1	5.4
5	11570.00	60.0 PK	74.0	-14.0	1.83 H	153	41.0	19.0
6	11570.00	46.8 AV	54.0	-7.2	1.83 H	153	27.8	19.0

ANTENNA POLARITY & TEST DISTANCE: VERTICAL AT 3 M

NO.	FREQ. (MHz)	EMISSION LEVEL (dBuV/m)	LIMIT (dBuV/m)	MARGIN (dB)	ANTENNA HEIGHT (m)	TABLE ANGLE (Degree)	RAW VALUE (dBuV)	CORRECTION FACTOR (dB/m)
1	#5616.00	58.0 PK	68.2	-10.2	1.59 V	345	53.5	4.5
2	*5785.00	118.3 PK			1.59 V	345	78.0	40.3
3	*5785.00	106.8 AV			1.59 V	345	66.5	40.3
4	#5940.80	57.2 PK	68.2	-11.0	1.59 V	345	51.8	5.4
5	11570.00	59.6 PK	74.0	-14.4	1.59 V	183	40.6	19.0
6	11570.00	46.6 AV	54.0	-7.4	1.59 V	183	27.6	19.0

Remarks:

1. Emission Level(dBuV/m) = Raw Value(dBuV) + Correction Factor(dB/m).
2. Correction Factor(dB/m) = Antenna Factor(dB/m) + Cable Factor(dB) – Pre-Amplifier Factor(dB).
3. Margin value = Emission Level – Limit value.
4. The other emission levels were very low against the limit.
5. " * " : Fundamental frequency.
6. " # " : The radiated frequency is out of the restricted band.

CHANNEL	TX Channel 165	DETECTOR FUNCTION	Peak (PK) Average (AV)
FREQUENCY RANGE	1GHz ~ 40GHz		

ANTENNA POLARITY & TEST DISTANCE: HORIZONTAL AT 3 M								
NO.	FREQ. (MHz)	EMISSION LEVEL (dBuV/m)	LIMIT (dBuV/m)	MARGIN (dB)	ANTENNA HEIGHT (m)	TABLE ANGLE (Degree)	RAW VALUE (dBuV)	CORRECTION FACTOR (dB/m)
1	#5604.00	62.1 PK	68.2	-6.1	1.56 H	346	57.6	4.5
2	*5825.00	119.9 PK			1.56 H	346	79.5	40.4
3	*5825.00	108.9 AV			1.56 H	346	68.5	40.4
4	#5963.20	58.2 PK	68.2	-10.0	1.56 H	346	52.8	5.4
5	11650.00	60.0 PK	74.0	-14.0	1.84 H	152	41.1	18.9
6	11650.00	46.8 AV	54.0	-7.2	1.84 H	152	27.9	18.9

ANTENNA POLARITY & TEST DISTANCE: VERTICAL AT 3 M								
NO.	FREQ. (MHz)	EMISSION LEVEL (dBuV/m)	LIMIT (dBuV/m)	MARGIN (dB)	ANTENNA HEIGHT (m)	TABLE ANGLE (Degree)	RAW VALUE (dBuV)	CORRECTION FACTOR (dB/m)
1	#5623.20	58.5 PK	68.2	-9.7	1.68 V	345	54.1	4.4
2	*5825.00	119.8 PK			1.68 V	345	79.4	40.4
3	*5825.00	108.7 AV			1.68 V	345	68.3	40.4
4	#5964.00	58.9 PK	68.2	-9.3	1.68 V	345	53.5	5.4
5	11650.00	59.6 PK	74.0	-14.4	1.61 V	171	40.7	18.9
6	11650.00	46.6 AV	54.0	-7.4	1.61 V	171	27.7	18.9

Remarks:

1. Emission Level(dBuV/m) = Raw Value(dBuV) + Correction Factor(dB/m).
2. Correction Factor(dB/m) = Antenna Factor(dB/m) + Cable Factor(dB) – Pre-Amplifier Factor(dB).
3. Margin value = Emission Level – Limit value.
4. The other emission levels were very low against the limit.
5. " * " : Fundamental frequency.
6. " # " : The radiated frequency is out of the restricted band.

802.11n (HT40)

CHANNEL	TX Channel 38	DETECTOR FUNCTION	Peak (PK) Average (AV)
FREQUENCY RANGE	1GHz ~ 40GHz		

ANTENNA POLARITY & TEST DISTANCE: HORIZONTAL AT 3 M								
NO.	FREQ. (MHz)	EMISSION LEVEL (dBuV/m)	LIMIT (dBuV/m)	MARGIN (dB)	ANTENNA HEIGHT (m)	TABLE ANGLE (Degree)	RAW VALUE (dBuV)	CORRECTION FACTOR (dB/m)
1	5150.00	66.7 PK	74.0	-7.3	1.48 H	346	62.5	4.2
2	5150.00	52.8 AV	54.0	-1.2	1.48 H	346	48.6	4.2
3	*5190.00	113.8 PK			1.44 H	344	74.5	39.3
4	*5190.00	103.5 AV			1.44 H	344	64.2	39.3
5	#10380.00	60.5 PK	68.2	-7.7	1.54 H	153	42.8	17.7

ANTENNA POLARITY & TEST DISTANCE: VERTICAL AT 3 M								
NO.	FREQ. (MHz)	EMISSION LEVEL (dBuV/m)	LIMIT (dBuV/m)	MARGIN (dB)	ANTENNA HEIGHT (m)	TABLE ANGLE (Degree)	RAW VALUE (dBuV)	CORRECTION FACTOR (dB/m)
1	5150.00	59.9 PK	74.0	-14.1	1.59 V	345	55.7	4.2
2	5150.00	46.2 AV	54.0	-7.8	1.59 V	345	42.0	4.2
3	*5190.00	112.8 PK			1.76 V	341	73.5	39.3
4	*5190.00	102.3 AV			1.76 V	341	63.0	39.3
5	#10380.00	61.1 PK	68.2	-7.1	1.40 V	178	43.4	17.7

Remarks:

1. Emission Level(dBuV/m) = Raw Value(dBuV) + Correction Factor(dB/m).
2. Correction Factor(dB/m) = Antenna Factor(dB/m) + Cable Factor(dB) – Pre-Amplifier Factor(dB).
3. Margin value = Emission Level – Limit value.
4. The other emission levels were very low against the limit.
5. " * ": Fundamental frequency.
6. " # ": The radiated frequency is out of the restricted band.

CHANNEL	TX Channel 46	DETECTOR FUNCTION	Peak (PK) Average (AV)
FREQUENCY RANGE	1GHz ~ 40GHz		

ANTENNA POLARITY & TEST DISTANCE: HORIZONTAL AT 3 M

NO.	FREQ. (MHz)	EMISSION LEVEL (dBuV/m)	LIMIT (dBuV/m)	MARGIN (dB)	ANTENNA HEIGHT (m)	TABLE ANGLE (Degree)	RAW VALUE (dBuV)	CORRECTION FACTOR (dB/m)
1	*5230.00	114.9 PK			1.55 H	344	75.8	39.1
2	*5230.00	104.7 AV			1.55 H	344	65.6	39.1
3	5350.00	62.3 PK	74.0	-11.7	1.59 H	350	58.2	4.1
4	5350.00	49.0 AV	54.0	-5.0	1.59 H	350	44.9	4.1
5	#10460.00	60.7 PK	68.2	-7.5	1.48 H	150	42.5	18.2

ANTENNA POLARITY & TEST DISTANCE: VERTICAL AT 3 M

NO.	FREQ. (MHz)	EMISSION LEVEL (dBuV/m)	LIMIT (dBuV/m)	MARGIN (dB)	ANTENNA HEIGHT (m)	TABLE ANGLE (Degree)	RAW VALUE (dBuV)	CORRECTION FACTOR (dB/m)
1	*5230.00	114.0 PK			1.61 V	342	74.9	39.1
2	*5230.00	103.4 AV			1.61 V	342	64.3	39.1
3	5350.00	60.5 PK	74.0	-13.5	1.51 V	349	56.4	4.1
4	5350.00	47.3 AV	54.0	-6.7	1.51 V	349	43.2	4.1
5	#10460.00	61.1 PK	68.2	-7.1	1.51 V	179	42.9	18.2

Remarks:

1. Emission Level(dBuV/m) = Raw Value(dBuV) + Correction Factor(dB/m).
2. Correction Factor(dB/m) = Antenna Factor(dB/m) + Cable Factor(dB) – Pre-Amplifier Factor(dB).
3. Margin value = Emission Level – Limit value.
4. The other emission levels were very low against the limit.
5. " * " : Fundamental frequency.
6. " # " : The radiated frequency is out of the restricted band.

CHANNEL	TX Channel 151	DETECTOR FUNCTION	Peak (PK) Average (AV)
FREQUENCY RANGE	1GHz ~ 40GHz		

ANTENNA POLARITY & TEST DISTANCE: HORIZONTAL AT 3 M

NO.	FREQ. (MHz)	EMISSION LEVEL (dBuV/m)	LIMIT (dBuV/m)	MARGIN (dB)	ANTENNA HEIGHT (m)	TABLE ANGLE (Degree)	RAW VALUE (dBuV)	CORRECTION FACTOR (dB/m)
1	#5604.80	61.3 PK	68.2	-6.9	1.53 H	347	56.8	4.5
2	*5755.00	117.0 PK			1.53 H	347	76.9	40.1
3	*5755.00	106.7 AV			1.53 H	347	66.6	40.1
4	#5968.80	58.5 PK	68.2	-9.7	1.53 H	347	53.1	5.4
5	11510.00	60.2 PK	74.0	-13.8	1.63 H	142	40.8	19.4
6	11510.00	47.0 AV	54.0	-7.0	1.63 H	142	27.6	19.4

ANTENNA POLARITY & TEST DISTANCE: VERTICAL AT 3 M

NO.	FREQ. (MHz)	EMISSION LEVEL (dBuV/m)	LIMIT (dBuV/m)	MARGIN (dB)	ANTENNA HEIGHT (m)	TABLE ANGLE (Degree)	RAW VALUE (dBuV)	CORRECTION FACTOR (dB/m)
1	#5600.80	57.8 PK	68.2	-10.4	1.55 V	345	53.3	4.5
2	*5755.00	114.4 PK			1.55 V	345	74.3	40.1
3	*5755.00	103.8 AV			1.55 V	345	63.7	40.1
4	#5938.40	58.8 PK	68.2	-9.4	1.55 V	345	53.4	5.4
5	11510.00	60.0 PK	74.0	-14.0	1.56 V	178	40.6	19.4
6	11510.00	46.9 AV	54.0	-7.1	1.56 V	178	27.5	19.4

Remarks:

1. Emission Level(dBuV/m) = Raw Value(dBuV) + Correction Factor(dB/m).
2. Correction Factor(dB/m) = Antenna Factor(dB/m) + Cable Factor(dB) – Pre-Amplifier Factor(dB).
3. Margin value = Emission Level – Limit value.
4. The other emission levels were very low against the limit.
5. " * " : Fundamental frequency.
6. " # " : The radiated frequency is out of the restricted band.

CHANNEL	TX Channel 159	DETECTOR FUNCTION	Peak (PK) Average (AV)
FREQUENCY RANGE	1GHz ~ 40GHz		

ANTENNA POLARITY & TEST DISTANCE: HORIZONTAL AT 3 M

NO.	FREQ. (MHz)	EMISSION LEVEL (dBuV/m)	LIMIT (dBuV/m)	MARGIN (dB)	ANTENNA HEIGHT (m)	TABLE ANGLE (Degree)	RAW VALUE (dBuV)	CORRECTION FACTOR (dB/m)
1	#5616.80	62.0 PK	68.2	-6.2	1.53 H	349	57.5	4.5
2	*5795.00	117.6 PK			1.53 H	349	77.2	40.4
3	*5795.00	107.3 AV			1.53 H	349	66.9	40.4
4	#5926.40	59.0 PK	68.2	-9.2	1.53 H	349	53.6	5.4
5	11590.00	60.0 PK	74.0	-14.0	1.88 H	147	41.1	18.9
6	11590.00	46.9 AV	54.0	-7.1	1.88 H	147	28.0	18.9

ANTENNA POLARITY & TEST DISTANCE: VERTICAL AT 3 M

NO.	FREQ. (MHz)	EMISSION LEVEL (dBuV/m)	LIMIT (dBuV/m)	MARGIN (dB)	ANTENNA HEIGHT (m)	TABLE ANGLE (Degree)	RAW VALUE (dBuV)	CORRECTION FACTOR (dB/m)
1	#5622.40	58.2 PK	68.2	-10.0	1.58 V	344	53.8	4.4
2	*5795.00	116.4 PK			1.58 V	344	76.0	40.4
3	*5795.00	105.4 AV			1.58 V	344	65.0	40.4
4	#5983.20	58.2 PK	68.2	-10.0	1.58 V	344	52.7	5.5
5	11590.00	59.6 PK	74.0	-14.4	1.53 V	170	40.7	18.9
6	11590.00	46.6 AV	54.0	-7.4	1.53 V	170	27.7	18.9

Remarks:

1. Emission Level(dBuV/m) = Raw Value(dBuV) + Correction Factor(dB/m).
2. Correction Factor(dB/m) = Antenna Factor(dB/m) + Cable Factor(dB) – Pre-Amplifier Factor(dB).
3. Margin value = Emission Level – Limit value.
4. The other emission levels were very low against the limit.
5. " * " : Fundamental frequency.
6. " # " : The radiated frequency is out of the restricted band.

802.11ac (VHT80)

CHANNEL	TX Channel 42	DETECTOR FUNCTION	Peak (PK) Average (AV)
FREQUENCY RANGE	1GHz ~ 40GHz		

ANTENNA POLARITY & TEST DISTANCE: HORIZONTAL AT 3 M

NO.	FREQ. (MHz)	EMISSION LEVEL (dBuV/m)	LIMIT (dBuV/m)	MARGIN (dB)	ANTENNA HEIGHT (m)	TABLE ANGLE (Degree)	RAW VALUE (dBuV)	CORRECTION FACTOR (dB/m)
1	5150.00	67.2 PK	74.0	-6.8	1.48 H	342	63.0	4.2
2	5150.00	52.7 AV	54.0	-1.3	1.48 H	342	48.5	4.2
3	*5210.00	109.4 PK			1.46 H	343	70.2	39.2
4	*5210.00	98.7 AV			1.46 H	343	59.5	39.2
5	5350.00	62.5 PK	74.0	-11.5	1.54 H	349	58.4	4.1
6	5350.00	49.3 AV	54.0	-4.7	1.54 H	349	45.2	4.1
7	#10420.00	60.4 PK	68.2	-7.8	1.51 H	152	42.5	17.9

ANTENNA POLARITY & TEST DISTANCE: VERTICAL AT 3 M

NO.	FREQ. (MHz)	EMISSION LEVEL (dBuV/m)	LIMIT (dBuV/m)	MARGIN (dB)	ANTENNA HEIGHT (m)	TABLE ANGLE (Degree)	RAW VALUE (dBuV)	CORRECTION FACTOR (dB/m)
1	5150.00	60.7 PK	74.0	-13.3	1.71 V	344	56.5	4.2
2	5150.00	46.9 AV	54.0	-7.1	1.71 V	344	42.7	4.2
3	*5210.00	109.2 PK			1.68 V	345	70.0	39.2
4	*5210.00	98.1 AV			1.68 V	345	58.9	39.2
5	5350.00	61.0 PK	74.0	-13.0	1.68 V	340	56.9	4.1
6	5350.00	48.0 AV	54.0	-6.0	1.68 V	340	43.9	4.1
7	#10420.00	61.1 PK	68.2	-7.1	1.46 V	177	43.2	17.9

Remarks:

1. Emission Level(dBuV/m) = Raw Value(dBuV) + Correction Factor(dB/m).
2. Correction Factor(dB/m) = Antenna Factor(dB/m) + Cable Factor(dB) – Pre-Amplifier Factor(dB).
3. Margin value = Emission Level – Limit value.
4. The other emission levels were very low against the limit.
5. " * ": Fundamental frequency.
6. " # ": The radiated frequency is out of the restricted band.

CHANNEL	TX Channel 155	DETECTOR FUNCTION	Peak (PK) Average (AV)
FREQUENCY RANGE	1GHz ~ 40GHz		

ANTENNA POLARITY & TEST DISTANCE: HORIZONTAL AT 3 M

NO.	FREQ. (MHz)	EMISSION LEVEL (dBuV/m)	LIMIT (dBuV/m)	MARGIN (dB)	ANTENNA HEIGHT (m)	TABLE ANGLE (Degree)	RAW VALUE (dBuV)	CORRECTION FACTOR (dB/m)
1	#5606.40	61.2 PK	68.2	-7.0	1.54 H	348	56.7	4.5
2	#5650.00	63.4 PK	68.2	-4.8	1.59 H	353	59.0	4.4
3	*5775.00	113.9 PK			1.54 H	348	73.7	40.2
4	*5775.00	103.6 AV			1.54 H	348	63.4	40.2
5	#5925.00	57.9 PK	68.2	-10.3	1.61 H	349	52.5	5.4
6	#5959.20	58.4 PK	68.2	-9.8	1.54 H	348	53.0	5.4
7	11550.00	59.7 PK	74.0	-14.3	1.91 H	147	40.5	19.2
8	11550.00	47.8 AV	54.0	-6.2	1.91 H	147	28.6	19.2

ANTENNA POLARITY & TEST DISTANCE: VERTICAL AT 3 M

NO.	FREQ. (MHz)	EMISSION LEVEL (dBuV/m)	LIMIT (dBuV/m)	MARGIN (dB)	ANTENNA HEIGHT (m)	TABLE ANGLE (Degree)	RAW VALUE (dBuV)	CORRECTION FACTOR (dB/m)
1	#5644.80	58.9 PK	68.2	-9.3	1.70 V	346	54.5	4.4
2	#5650.00	59.1 PK	68.2	-9.1	1.64 V	350	54.7	4.4
3	*5775.00	111.5 PK			1.70 V	346	71.3	40.2
4	*5775.00	100.7 AV			1.70 V	346	60.5	40.2
5	#5925.00	59.3 PK	68.2	-8.9	1.73 V	344	53.9	5.4
6	#5934.40	59.0 PK	68.2	-9.2	1.70 V	346	53.6	5.4
7	11550.00	59.5 PK	74.0	-14.5	1.58 V	169	40.3	19.2
8	11550.00	47.6 AV	54.0	-6.4	1.58 V	169	28.4	19.2

Remarks:

1. Emission Level(dBuV/m) = Raw Value(dBuV) + Correction Factor(dB/m).
2. Correction Factor(dB/m) = Antenna Factor(dB/m) + Cable Factor(dB) – Pre-Amplifier Factor(dB).
3. Margin value = Emission Level – Limit value.
4. The other emission levels were very low against the limit.
5. " * ": Fundamental frequency.
6. " # ": The radiated frequency is out of the restricted band.

Below 1GHz Worst-Case Data:

802.11n (HT20)

CHANNEL	TX Channel 165	DETECTOR FUNCTION	Quasi-Peak (QP)
FREQUENCY RANGE	9kHz ~ 1GHz		

ANTENNA POLARITY & TEST DISTANCE: HORIZONTAL AT 3 M								
NO.	FREQ. (MHz)	EMISSION LEVEL (dBuV/m)	LIMIT (dBuV/m)	MARGIN (dB)	ANTENNA HEIGHT (m)	TABLE ANGLE (Degree)	RAW VALUE (dBuV)	CORRECTION FACTOR (dB/m)
1	57.16	26.7 QP	40.0	-13.3	1.99 H	146	36.0	-9.3
2	70.74	24.3 QP	40.0	-15.7	1.99 H	228	35.5	-11.2
3	144.46	23.2 QP	43.5	-20.3	1.99 H	248	32.1	-8.9
4	218.18	28.5 QP	46.0	-17.5	1.99 H	15	39.1	-10.6
5	491.72	28.3 QP	46.0	-17.7	1.00 H	289	30.0	-1.7
6	526.64	29.3 QP	46.0	-16.7	1.00 H	169	30.2	-0.9

Remarks:

1. Emission Level(dBuV/m) = Raw Value(dBuV) + Correction Factor(dB/m)
2. Correction Factor(dB/m) = Antenna Factor(dB/m) + Cable Factor(dB) – Pre-Amplifier Factor(dB)
3. The other emission levels were very low against the limit of frequency range 30MHz ~ 1000MHz
4. Margin value = Emission Level – Limit value
5. The emission levels were very low against the limit of frequency range 9kHz ~ 30MHz: the amplitude of spurious emissions attenuated more than 20 dB below the permissible value to be report

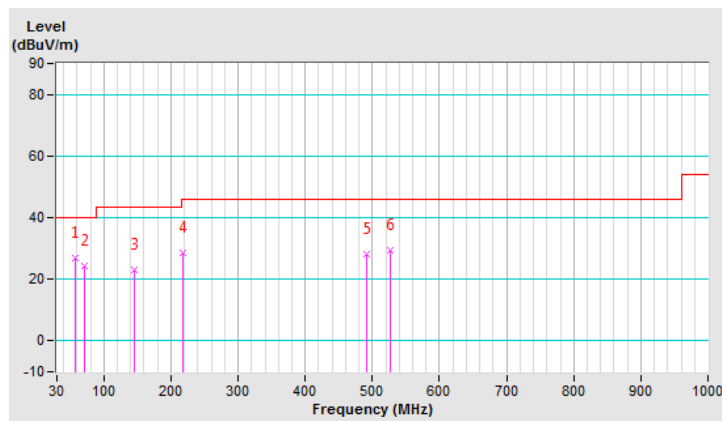

CHANNEL	TX Channel 165	DETECTOR FUNCTION	Quasi-Peak (QP)
FREQUENCY RANGE	9kHz ~ 1GHz		

ANTENNA POLARITY & TEST DISTANCE: VERTICAL AT 3 M								
NO.	FREQ. (MHz)	EMISSION LEVEL (dBuV/m)	LIMIT (dBuV/m)	MARGIN (dB)	ANTENNA HEIGHT (m)	TABLE ANGLE (Degree)	RAW VALUE (dBuV)	CORRECTION FACTOR (dB/m)
1	31.94	28.5 QP	40.0	-11.5	1.51 V	104	39.3	-10.8
2	76.56	31.4 QP	40.0	-8.6	1.51 V	117	44.0	-12.6
3	165.80	23.3 QP	43.5	-20.2	2.00 V	338	32.1	-8.8
4	336.52	22.9 QP	46.0	-23.1	1.00 V	80	29.3	-6.4
5	520.82	28.9 QP	46.0	-17.1	2.00 V	50	29.9	-1.0
6	677.96	31.2 QP	46.0	-14.8	1.51 V	163	29.4	1.8

Remarks:

1. Emission Level(dBuV/m) = Raw Value(dBuV) + Correction Factor(dB/m)
2. Correction Factor(dB/m) = Antenna Factor(dB/m) + Cable Factor(dB) – Pre-Amplifier Factor(dB)
3. The other emission levels were very low against the limit of frequency range 30MHz ~ 1000MHz
4. Margin value = Emission Level – Limit value
5. The emission levels were very low against the limit of frequency range 9kHz ~ 30MHz: the amplitude of spurious emissions attenuated more than 20 dB below the permissible value to be report

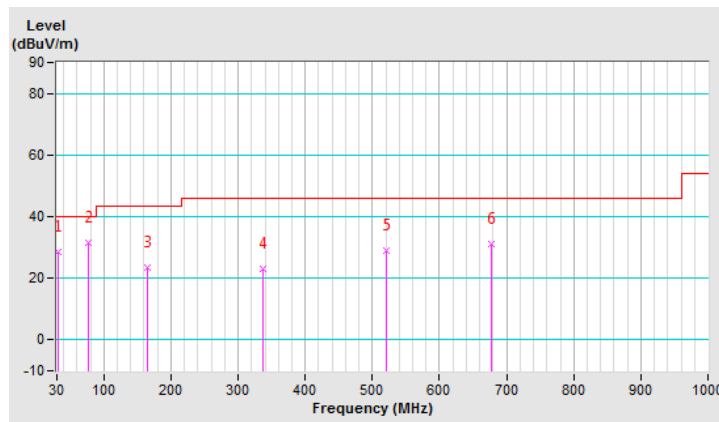

4.2 Conducted Emission Measurement

4.2.1 Limits of Conducted Emission Measurement

Frequency (MHz)	Conducted Limit (dBuV)	
	Quasi-peak	Average
0.15 - 0.5	66 - 56	56 - 46
0.50 - 5.0	56	46
5.0 - 30.0	60	50

Note: 1. The lower limit shall apply at the transition frequencies.

2. The limit decreases in line with the logarithm of the frequency in the range of 0.15 to 0.50MHz.

4.2.2 Test Instruments

Description & Manufacturer	Model No.	Serial No.	Cal. Date	Cal. Due
Test Receiver ROHDE & SCHWARZ	ESCI	100613	Dec. 10, 2018	Dec. 09, 2019
RF signal cable Woken	5D-FB	Cable-cond1-01	Sep. 05, 2019	Sep. 04, 2020
LISN ROHDE & SCHWARZ (EUT)	ENV216	101826	Feb. 21, 2019	Feb. 20, 2020
LISN ROHDE & SCHWARZ (Peripheral)	ESH3-Z5	100311	Aug. 22, 2019	Aug. 21, 2020
Software ADT	BV ADT_Cond_ V7.3.7.4	NA	NA	NA

Note: 1. The calibration interval of the above test instruments is 12 months and the calibrations are traceable to NML/ROC and NIST/USA.

2. The test was performed in HwaYa Shielded Room 1.

3. The VCCI Site Registration No. is C-12040.

4.2.3 Test Procedures

- The EUT was placed 0.4 meters from the conducting wall of the shielded room with EUT being connected to the power mains through a line impedance stabilization network (LISN). Other support units were connected to the power mains through another LISN. The two LISNs provide 50 ohm/ 50uH of coupling impedance for the measuring instrument.
- Both lines of the power mains connected to the EUT were checked for maximum conducted interference.
- The frequency range from 150kHz to 30MHz was searched. Emission levels under (Limit - 20dB) was not recorded.

Note: The resolution bandwidth and video bandwidth of test receiver is 9kHz for quasi-peak detection (QP) and average detection (AV) at frequency 0.15MHz-30MHz.

4.2.4 Deviation from Test Standard

No deviation.

4.2.5 Test Setup

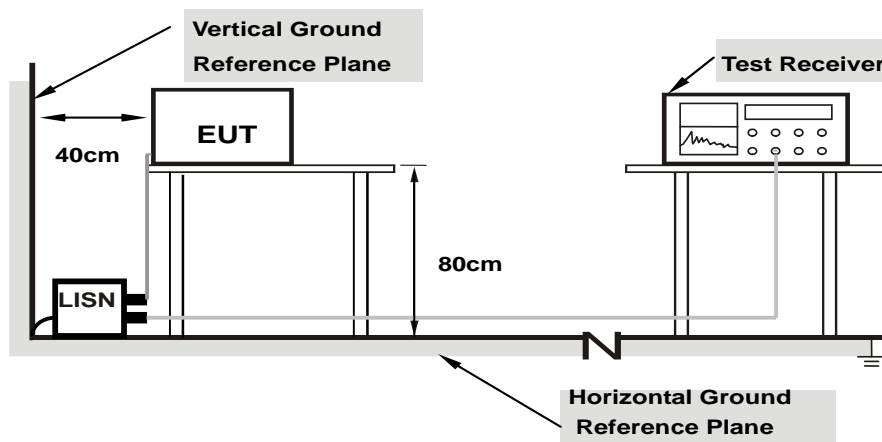

Note: 1.Support units were connected to second LISN.

For the actual test configuration, please refer to the attached file (Test Setup Photo).

4.2.6 EUT Operating Conditions

Same as 4.1.6.

4.2.7 Test Results

Worst-case data:

802.11n (HT20)

Phase	Line (L)	Detector Function	Quasi-Peak (QP) / Average (AV)
-------	----------	-------------------	--------------------------------

No	Freq. [MHz]	Corr. Factor (dB)	Reading Value [dB (uV)]		Emission Level [dB (uV)]		Limit [dB (uV)]		Margin (dB)	
			Q.P.	AV.	Q.P.	AV.	Q.P.	AV.	Q.P.	AV.
			1	0.15391	9.67	41.64	25.44	51.31	35.11	65.79
2	0.16955	9.67	39.12	23.40	48.79	33.07	64.98	54.98	-16.19	-21.91
3	0.18128	9.66	36.83	21.18	46.49	30.84	64.43	54.43	-17.94	-23.59
4	0.18910	9.66	35.94	21.87	45.60	31.53	64.08	54.08	-18.48	-22.55
5	0.20474	9.66	32.44	17.59	42.10	27.25	63.42	53.42	-21.32	-26.17
6	0.30640	9.68	29.78	22.68	39.46	32.36	60.07	50.07	-20.61	-17.71

Remarks:

1. Q.P. and AV. are abbreviations of quasi-peak and average individually.
2. The emission levels of other frequencies were very low against the limit.
3. Margin value = Emission level - Limit value
4. Correction factor = Insertion loss + Cable loss
5. Emission Level = Correction Factor + Reading Value.

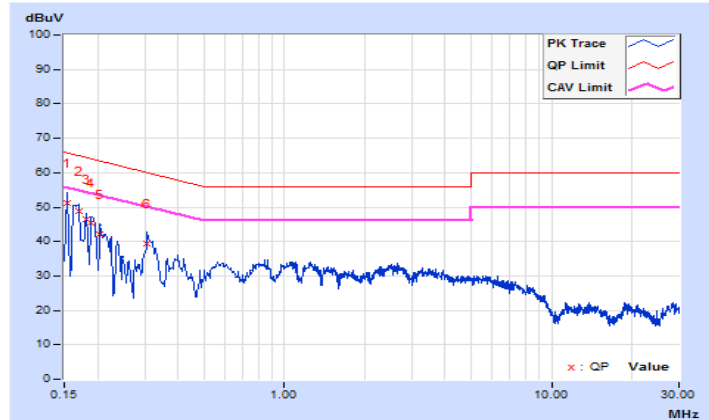

Phase	Neutral (N)	Detector Function	Quasi-Peak (QP) / Average (AV)
-------	-------------	-------------------	--------------------------------

No	Freq. [MHz]	Corr. Factor (dB)	Reading Value [dB (uV)]		Emission Level [dB (uV)]		Limit [dB (uV)]		Margin (dB)	
			Q.P.	AV.	Q.P.	AV.	Q.P.	AV.	Q.P.	AV.
			1	0.15391	9.64	40.05	22.77	49.69	32.41	65.79
2	0.16955	9.64	37.52	20.64	47.16	30.28	64.98	54.98	-17.82	-24.70
3	0.19692	9.64	31.78	16.10	41.42	25.74	63.74	53.74	-22.32	-28.00
4	0.21256	9.64	30.33	16.12	39.97	25.76	63.10	53.10	-23.13	-27.34
5	0.31021	9.65	26.38	18.81	36.03	28.46	59.96	49.96	-23.93	-21.50
6	0.36526	9.66	17.76	8.77	27.42	18.43	58.61	48.61	-31.19	-30.18

Remarks:

1. Q.P. and AV. are abbreviations of quasi-peak and average individually.
2. The emission levels of other frequencies were very low against the limit.
3. Margin value = Emission level - Limit value
4. Correction factor = Insertion loss + Cable loss
5. Emission Level = Correction Factor + Reading Value.

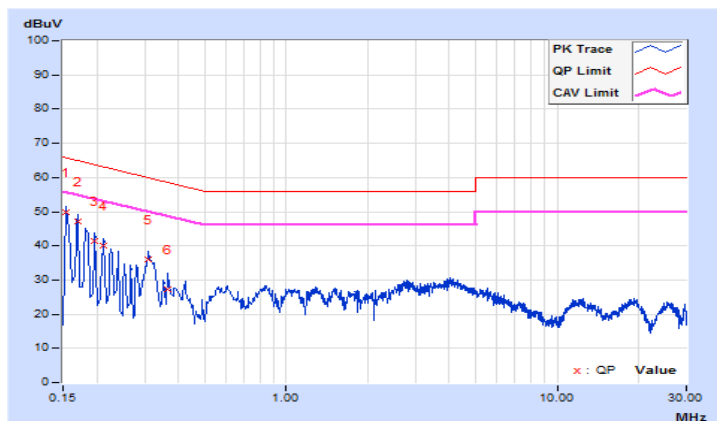

4.3 Transmit Power Measurement

4.3.1 Limits of Transmit Power Measurement

Operation Band	EUT Category		Limit
U-NII-1	√	Outdoor Access Point	1 Watt (30 dBm) (Max. e.i.r.p ≤ 125mW(21 dBm) at any elevation angle above 30 degrees as measured from the horizon)
		Fixed point-to-point Access Point	1 Watt (30 dBm)
		Indoor Access Point	1 Watt (30 dBm)
		Mobile and Portable client device	250mW (24 dBm)
U-NII-2A			250mW (24 dBm) or 11 dBm+10 log B*
U-NII-2C			250mW (24 dBm) or 11 dBm+10 log B*
U-NII-3	√		1 Watt (30 dBm)

*B is the 26 dB emission bandwidth in megahertz

Per KDB 662911 Method of conducted output power measurement on IEEE 802.11 devices,

Array Gain = 0 dB (i.e., no array gain) for $N_{ANT} \leq 4$;

Array Gain = 0 dB (i.e., no array gain) for channel widths ≥ 40 MHz for any N_{ANT} ;

Array Gain = $5 \log(N_{ANT}/N_{SS})$ dB or 3 dB, whichever is less for 20-MHz channel widths with $N_{ANT} \geq 5$.

For power measurements on all other devices: Array Gain = $10 \log(N_{ANT}/N_{SS})$ dB.

4.3.2 Test Setup

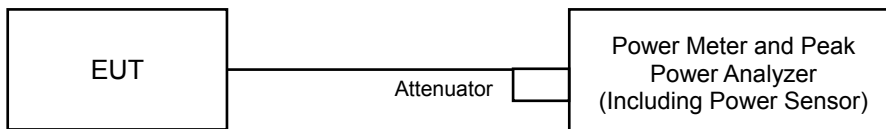

4.3.3 Test Instruments

Refer to section 4.1.2 to get information of above instrument.

4.3.4 Test Procedure

Method PM is used to perform output power measurement, trigger and gating function of wide band power meter is enabled to measure max output power of TX on burst and set the detector to average. Duty factor is not added to measured value.

4.3.5 EUT Operating Conditions

The software provided by client to enable the EUT under transmission condition continuously at lowest, middle and highest channel frequencies individually.

4.3.6 Test Result

For U-NII-1 Band (Outdoor Access Point)

CDD Mode

802.11a

Chan.	Freq. (MHz)	Conducted Power (dBm)		Total Power (mW)	Total Power (dBm)	Power Limit (dBm)	Ant. Gain (dBi)	EIRP (dBm)	EIRP limit (dBm)	Pass / Fail
		Chain 0	Chain 1							
36	5180	16.90	18.26	115.966	20.64	21.89	0.11	20.75	21.00	Pass
40	5200	16.93	18.18	115.083	20.61	21.89	0.11	20.72	21.00	Pass
48	5240	16.96	18.34	117.893	20.71	21.89	0.11	20.82	21.00	Pass

Note:

1. Antenna gain = 14.11dBi > 6dBi, so the power limit shall be reduced to $30-(14.11-6) = 21.89$ dBm.
2. Antenna gain = 0.11dBi (above 30 degrees from the horizon).
3. EIRP = conducted power + (0.11dBi) + array gain = (0 dB (i.e., no array gain) for $N_{ANT} \leq 4$).

802.11n (HT20)

Chan.	Freq. (MHz)	Conducted Power (dBm)		Total Power (mW)	Total Power (dBm)	Power Limit (dBm)	Ant. Gain (dBi)	EIRP (dBm)	EIRP limit (dBm)	Pass / Fail
		Chain 0	Chain 1							
36	5180	17.13	18.30	119.250	20.76	21.89	0.11	20.87	21.00	Pass
40	5200	17.28	18.36	122.005	20.86	21.89	0.11	20.97	21.00	Pass
48	5240	16.77	18.24	114.215	20.58	21.89	0.11	20.69	21.00	Pass

Note:

1. Antenna gain = 14.11dBi > 6dBi, so the power limit shall be reduced to $30-(14.11-6) = 21.89$ dBm.
2. Antenna gain = 0.11dBi (above 30 degrees from the horizon).
3. EIRP = conducted power + (0.11dBi) + array gain = (0 dB (i.e., no array gain) for $N_{ANT} \leq 4$).

802.11n (HT40)

Chan.	Freq. (MHz)	Conducted Power (dBm)		Total Power (mW)	Total Power (dBm)	Power Limit (dBm)	Ant. Gain (dBi)	EIRP (dBm)	EIRP limit (dBm)	Pass / Fail
		Chain 0	Chain 1							
38	5190	15.24	16.45	77.577	18.90	21.89	0.11	19.01	21.00	Pass
46	5230	16.91	18.15	114.404	20.58	21.89	0.11	20.69	21.00	Pass

Note:

1. Antenna gain = 14.11dBi > 6dBi, so the power limit shall be reduced to $30-(14.11-6) = 21.89$ dBm.
2. Antenna gain = 0.11dBi (above 30 degrees from the horizon).
3. EIRP = conducted power + (0.11dBi) + array gain = (0 dB (i.e., no array gain) for $N_{ANT} \leq 4$).

802.11ac (VHT80)

Chan.	Freq. (MHz)	Conducted Power (dBm)		Total Power (mW)	Total Power (dBm)	Power Limit (dBm)	Ant. Gain (dBi)	EIRP (dBm)	EIRP limit (dBm)	Pass / Fail
		Chain 0	Chain 1							
42	5210	14.01	15.29	58.983	17.71	21.89	0.11	17.82	21.00	Pass

Note:

1. Antenna gain = 14.11dBi > 6dBi, so the power limit shall be reduced to $30-(14.11-6) = 21.89$ dBm.
2. Antenna gain = 0.11dBi (above 30 degrees from the horizon).
3. EIRP = conducted power + (0.11dBi) + array gain = (0 dB (i.e., no array gain) for $N_{ANT} \leq 4$).

Beamforming Mode

802.11n (HT20)

Chan.	Freq. (MHz)	Conducted Power (dBm)		Total Power (mW)	Total Power (dBm)	Power Limit (dBm)	Gain (dBi)	EIRP (dBm)	EIRP limit (dBm)	Pass / Fail
		Chain 0	Chain 1							
36	5180	14.12	15.29	59.629	17.75	18.88	0.11	20.87	21.00	Pass
40	5200	14.27	15.35	61.007	17.85	18.88	0.11	20.97	21.00	Pass
48	5240	13.76	15.23	57.111	17.57	18.88	0.11	20.69	21.00	Pass

Note:

1. Directional gain = $14.11\text{dBi} + 10\log(2) = 17.12\text{dBi} > 6\text{dBi}$, so the power limit shall be reduced to $30 - (17.12 - 6) = 18.88\text{dBm}$.
2. Antenna gain = 0.11dBi (above 30 degrees from the horizon).
3. Beamforming gain = 3.01dBi
4. EIRP = conducted power + (0.11dBi) + beamforming gain (3.01dBi) .

802.11n (HT40)

Chan.	Freq. (MHz)	Conducted Power (dBm)		Total Power (mW)	Total Power (dBm)	Power Limit (dBm)	Gain (dBi)	EIRP (dBm)	EIRP limit (dBm)	Pass / Fail
		Chain 0	Chain 1							
38	5190	12.23	13.44	38.791	15.89	18.88	0.11	19.01	21.00	Pass
46	5230	13.90	15.14	57.206	17.57	18.88	0.11	20.69	21.00	Pass

Note:

1. Directional gain = $14.11\text{dBi} + 10\log(2) = 17.12\text{dBi} > 6\text{dBi}$, so the power limit shall be reduced to $30 - (17.12 - 6) = 18.88\text{dBm}$.
2. Antenna gain = 0.11dBi (above 30 degrees from the horizon).
3. Beamforming gain = 3.01dBi
4. EIRP = conducted power + (0.11dBi) + beamforming gain (3.01dBi) .

802.11ac (VHT80)

Chan.	Freq. (MHz)	Conducted Power (dBm)		Total Power (mW)	Total Power (dBm)	Power Limit (dBm)	Gain (dBi)	EIRP (dBm)	EIRP limit (dBm)	Pass / Fail
		Chain 0	Chain 1							
42	5210	11.00	12.28	29.493	14.70	18.88	0.11	17.82	21.00	Pass

Note:

1. Directional gain = $14.11\text{dBi} + 10\log(2) = 17.12\text{dBi} > 6\text{dBi}$, so the power limit shall be reduced to $30 - (17.12 - 6) = 18.88\text{dBm}$.
2. Antenna gain = 0.11dBi (above 30 degrees from the horizon).
3. Beamforming gain = 3.01dBi
4. EIRP = conducted power + (0.11dBi) + beamforming gain (3.01dBi) .

For U-NII-3 band

CDD Mode

802.11a

Chan.	Freq. (MHz)	Maximum Conducted Power (dBm)		Total Power (mW)	Total Power (dBm)	Power Limit (dBm)	Pass / Fail
		Chain 0	Chain 1				
149	5745	17.44	19.39	142.359	21.53	21.89	Pass
157	5785	17.74	19.56	149.794	21.75	21.89	Pass
165	5825	17.53	19.45	144.729	21.61	21.89	Pass

Note: Antenna gain = 14.11dBi > 6dBi, so the power limit shall be reduced to $30-(14.11-6) = 21.89$ dBm.

802.11n (HT20)

Chan.	Freq. (MHz)	Maximum Conducted Power (dBm)		Total Power (mW)	Total Power (dBm)	Power Limit (dBm)	Pass / Fail
		Chain 0	Chain 1				
149	5745	17.51	19.35	142.463	21.54	21.89	Pass
157	5785	17.53	19.37	143.121	21.56	21.89	Pass
165	5825	17.81	19.66	152.865	21.84	21.89	Pass

Note: Antenna gain = 14.11dBi > 6dBi, so the power limit shall be reduced to $30-(14.11-6) = 21.89$ dBm.

802.11n (HT40)

Chan.	Freq. (MHz)	Maximum Conducted Power (dBm)		Total Power (mW)	Total Power (dBm)	Power Limit (dBm)	Pass / Fail
		Chain 0	Chain 1				
151	5755	17.57	19.43	144.848	21.61	21.89	Pass
159	5795	17.73	19.61	150.704	21.78	21.89	Pass

Note: Antenna gain = 14.11dBi > 6dBi, so the power limit shall be reduced to $30-(14.11-6) = 21.89$ dBm.

802.11ac (VHT80)

Chan.	Freq. (MHz)	Maximum Conducted Power (dBm)		Total Power (mW)	Total Power (dBm)	Power Limit (dBm)	Pass / Fail
		Chain 0	Chain 1				
155	5775	17.54	19.33	142.458	21.54	21.89	Pass

Note: Antenna gain = 14.11dBi > 6dBi, so the power limit shall be reduced to $30-(14.11-6) = 21.89$ dBm.

Beamforming Mode

802.11n (HT20)

Chan.	Freq. (MHz)	Maximum Conducted Power (dBm)		Total Power (mW)	Total Power (dBm)	Power Limit (dBm)	Pass / Fail
		Chain 0	Chain 1				
149	5745	14.50	16.34	71.237	18.53	18.88	Pass
157	5785	14.52	16.36	71.565	18.55	18.88	Pass
165	5825	14.80	16.65	76.438	18.83	18.88	Pass

Note: Directional gain = $14.11\text{dBi} + 10\log(2) = 17.12\text{dBi} > 6\text{dBi}$, so the power limit shall be reduced to $30 - (17.12 - 6) = 18.88\text{dBm}$.

802.11n (HT40)

Chan.	Freq. (MHz)	Maximum Conducted Power (dBm)		Total Power (mW)	Total Power (dBm)	Power Limit (dBm)	Pass / Fail
		Chain 0	Chain 1				
151	5755	14.56	16.42	72.429	18.60	18.88	Pass
159	5795	14.72	16.60	75.357	18.77	18.88	Pass

Note: Directional gain = $14.11\text{dBi} + 10\log(2) = 17.12\text{dBi} > 6\text{dBi}$, so the power limit shall be reduced to $30 - (17.12 - 6) = 18.88\text{dBm}$.

802.11ac (VHT80)

Chan.	Freq. (MHz)	Maximum Conducted Power (dBm)		Total Power (mW)	Total Power (dBm)	Power Limit (dBm)	Pass / Fail
		Chain 0	Chain 1				
155	5775	14.53	16.32	71.234	18.53	18.88	Pass

Note: Directional gain = $14.11\text{dBi} + 10\log(2) = 17.12\text{dBi} > 6\text{dBi}$, so the power limit shall be reduced to $30 - (17.12 - 6) = 18.88\text{dBm}$.

4.4 Occupied Bandwidth Measurement

4.4.1 Test Setup

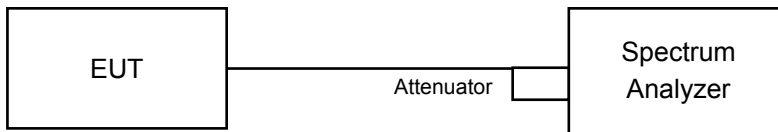

4.4.2 Test Instruments

Refer to section 4.1.2 to get information of above instrument.

4.4.3 Test Procedure

The transmitter output was connected to the spectrum analyzer through an attenuator. The bandwidth of the fundamental frequency was measured by spectrum analyzer with resolution bandwidth in the range of 1% to 5% of the anticipated emission bandwidth, and a video bandwidth at least 3x the resolution bandwidth and set the detector to sampling. The width of a frequency band such that, below the lower and above the upper frequency limits, the mean powers emitted are each equal to a specified percentage 0.5 %of the total mean power of a given emission.

4.4.4 Test Result

802.11a

Chan.	Freq. (MHz)	Occupied Bandwidth (MHz)	
		Chain 0	Chain 1
36	5180	16.44	16.44
40	5200	16.56	16.44
48	5240	16.44	16.44
149	5745	16.44	16.44
157	5785	16.44	16.44
165	5825	16.44	16.44

802.11n (HT20)

Chan.	Freq. (MHz)	Occupied Bandwidth (MHz)	
		Chain 0	Chain 1
36	5180	17.64	17.64
40	5200	17.64	17.64
48	5240	17.64	17.64
149	5745	17.64	17.64
157	5785	17.64	17.64
165	5825	17.64	17.64

802.11n (HT40)

Chan.	Freq. (MHz)	Occupied Bandwidth (MHz)	
		Chain 0	Chain 1
38	5190	36.12	36.00
46	5230	36.12	36.00
151	5755	36.12	35.88
159	5795	36.00	36.00

802.11ac (VHT80)

Chan.	Freq. (MHz)	Occupied Bandwidth (MHz)	
		Chain 0	Chain 1
42	5210	75.84	75.84
155	5775	75.84	75.84

Spectrum Plot of Worst Value

802.11a

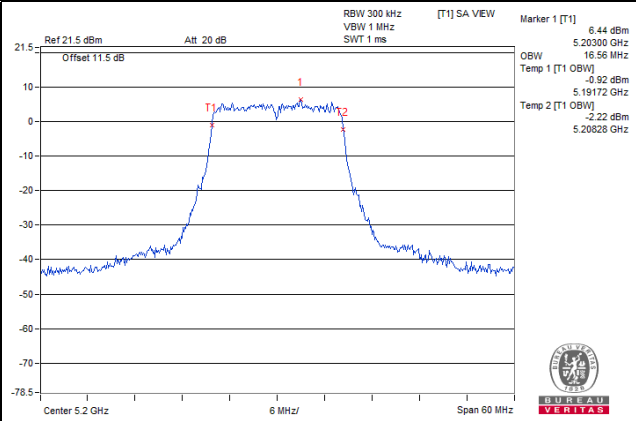

802.11n (HT20)

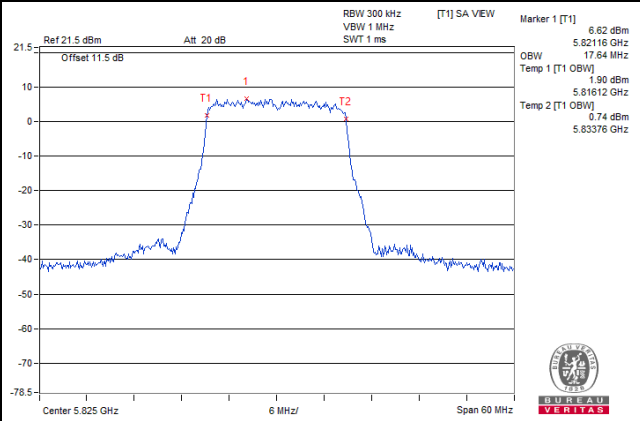

802.11n (HT40)

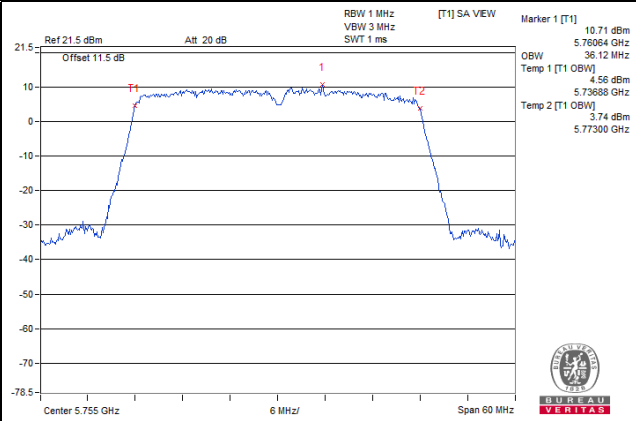

802.11ac (VHT80)

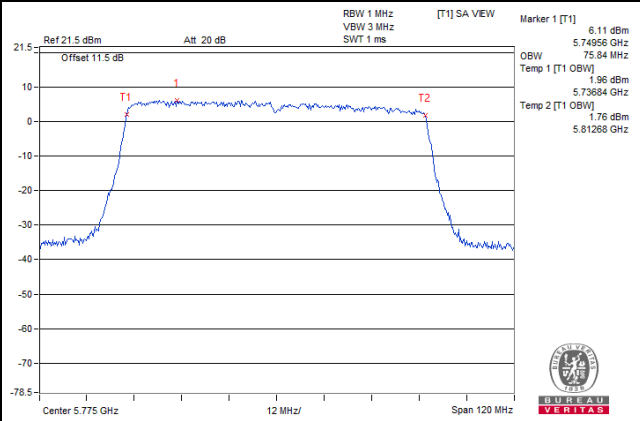

4.5 Peak Power Spectral Density Measurement

4.5.1 Limits of Peak Power Spectral Density Measurement

Operation Band	EUT Category		Limit
U-NII-1	√	Outdoor Access Point	17dBm/ MHz
		Fixed point-to-point Access Point	
		Indoor Access Point	
		Mobile and Portable client device	11dBm/ MHz
U-NII-2A			11dBm/ MHz
U-NII-2C			11dBm/ MHz
U-NII-3	√		30dBm/ 500kHz

4.5.2 Test Setup

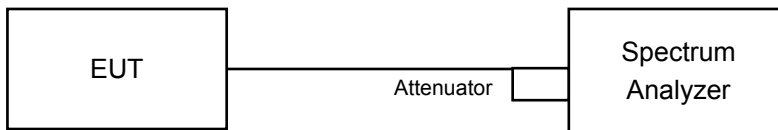

4.5.3 Test Instruments

Refer to section 4.1.2 to get information of above instrument.

4.5.4 Test Procedures

For U-NII-1 band:

Using method SA-2

- Set span to encompass the entire emission bandwidth (EBW) of the signal.
- Set RBW = 1MHz, Set VBW \geq 3 MHz, Detector = RMS
- Set Channel power measure = 1MHz
- Sweep time = auto, trigger set to "free run".
- Trace average at least 100 traces in power averaging mode.
- Record the max value and add $10 \log (1/\text{duty cycle})$

For U-NII-3 band:

- Set span to encompass the entire emission bandwidth (EBW) of the signal.
- Set RBW = 300 kHz, Set VBW \geq 1 MHz, Detector = RMS
- Use the peak marker function to determine the maximum power level in any 300 kHz band segment within the fundamental EBW.
- Scale the observed power level to an equivalent value in 500 kHz by adjusting (reducing) the measured power by a bandwidth correction factor (BWCF) where $\text{BWCF} = 10 \log(500 \text{ kHz} / 300 \text{ kHz})$
- Sweep time = auto, trigger set to "free run".
- Trace average at least 100 traces in power averaging mode.
- Record the max value and add $10 \log (1/\text{duty cycle})$

4.5.5 Deviation from Test Standard

No deviation.

4.5.6 EUT Operating Conditions

Same as 4.3.6.

4.5.7 Test Results

For U-NII-1 band:

802.11a

Chan.	Freq. (MHz)	PSD w/o Duty Factor (dBm/MHz)		Duty Factor (dB)	Total PSD with Duty Factor (dBm/MHz)	Max. Limit (dBm/MHz)	Pass / Fail
		Chain 0	Chain 1				
36	5180	1.72	2.61	0.19	5.39	5.88	Pass
40	5200	1.77	2.64	0.19	5.43	5.88	Pass
48	5240	1.64	3.48	0.19	5.86	5.88	Pass

Note:

- Method E) 2) a) of power density measurement of KDB 662911 is using for calculating total power density. Total power density is summing entire spectra across corresponding frequency bins on the various outputs by computer.
- Directional gain = $14.11\text{dBi} + 10\log(2) = 17.12\text{dBi} > 6\text{dBi}$, so the power density limit shall be reduced to $17-(17.12-6) = 5.88\text{dBm}$.
- Refer to section 3.3 for duty cycle spectrum plot.

802.11n (HT20)

Chan.	Freq. (MHz)	PSD w/o Duty Factor (dBm/MHz)		Duty Factor (dB)	Total PSD with Duty Factor (dBm/MHz)	Max. Limit (dBm/MHz)	Pass / Fail
		Chain 0	Chain 1				
36	5180	1.80	3.14	0.09	5.62	5.88	Pass
40	5200	1.93	2.56	0.09	5.36	5.88	Pass
48	5240	0.96	3.02	0.09	5.21	5.88	Pass

Note:

- Method E) 2) a) of power density measurement of KDB 662911 is using for calculating total power density. Total power density is summing entire spectra across corresponding frequency bins on the various outputs by computer.
- Directional gain = $14.11\text{dBi} + 10\log(2) = 17.12\text{dBi} > 6\text{dBi}$, so the power density limit shall be reduced to $17-(17.12-6) = 5.88\text{dBm}$.
- Refer to section 3.3 for duty cycle spectrum plot.

802.11n (HT40)

Chan.	Freq. (MHz)	PSD w/o Duty Factor (dBm/MHz)		Duty Factor (dB)	Total PSD with Duty Factor (dBm/MHz)	Max. Limit (dBm/MHz)	Pass / Fail
		Chain 0	Chain 1				
38	5190	-3.19	-2.09	0.16	0.56	5.88	Pass
46	5230	-1.01	0.15	0.16	2.78	5.88	Pass

Note:

- Method E) 2) a) of power density measurement of KDB 662911 is using for calculating total power density. Total power density is summing entire spectra across corresponding frequency bins on the various outputs by computer.
- Directional gain = $14.11\text{dBi} + 10\log(2) = 17.12\text{dBi} > 6\text{dBi}$, so the power density limit shall be reduced to $17-(17.12-6) = 5.88\text{dBm}$.
- Refer to section 3.3 for duty cycle spectrum plot.

802.11ac (VHT80)

Chan.	Freq. (MHz)	PSD w/o Duty Factor (dBm/MHz)		Duty Factor (dB)	Total PSD with Duty Factor (dBm/MHz)	Max. Limit (dBm/MHz)	Pass / Fail
		Chain 0	Chain 1				
42	5210	-7.14	-6.91	0.27	-3.74	5.88	Pass

Note:

- Method E) 2) a) of power density measurement of KDB 662911 is using for calculating total power density. Total power density is summing entire spectra across corresponding frequency bins on the various outputs by computer.
- Directional gain = $14.11\text{dBi} + 10\log(2) = 17.12\text{dBi} > 6\text{dBi}$, so the power density limit shall be reduced to $17 - (17.12 - 6) = 5.88\text{dBm}$.
- Refer to section 3.3 for duty cycle spectrum plot.

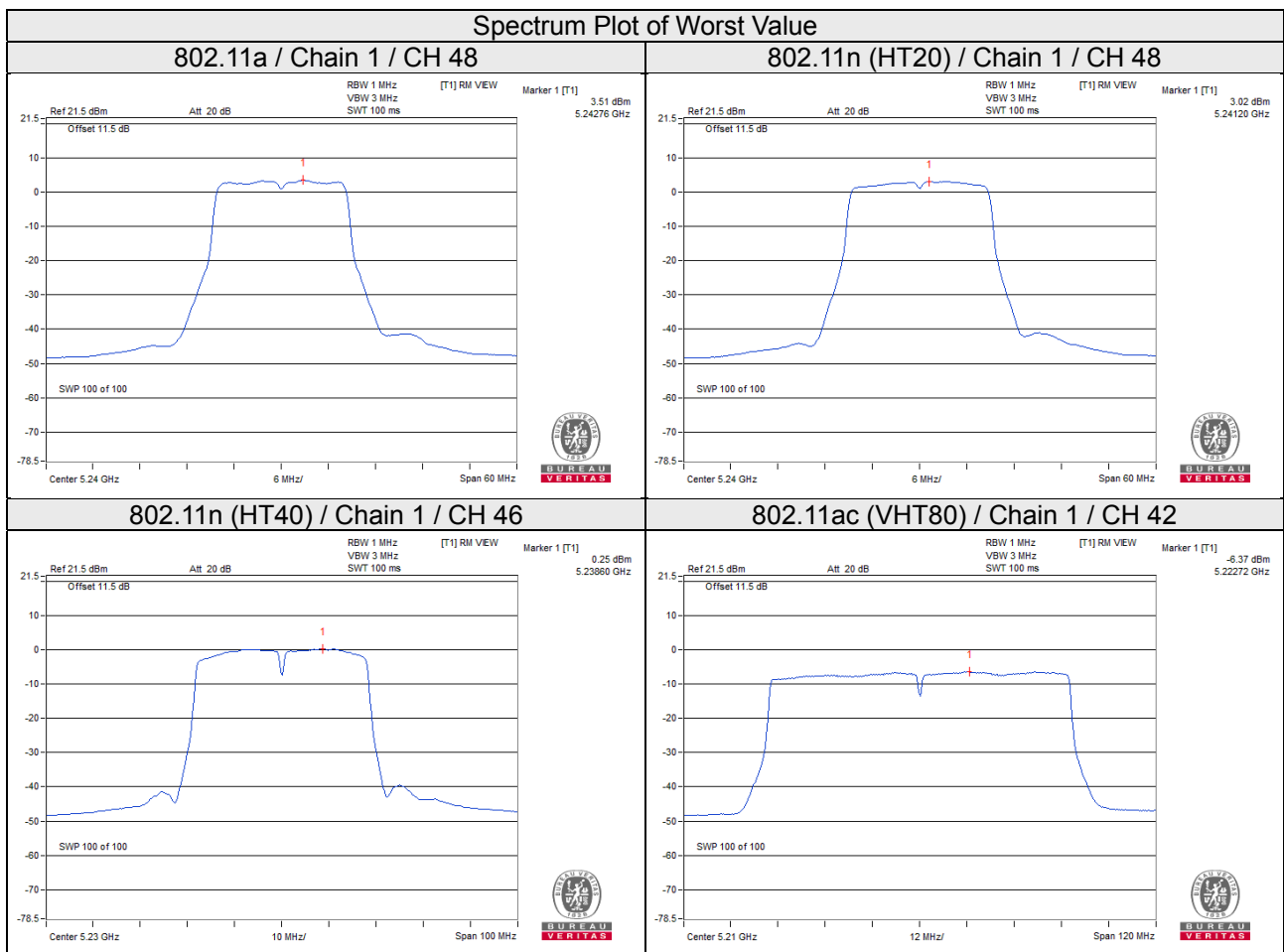

For U-NII-3 band:

802.11a

TX chain	Chan.	Freq. (MHz)	PSD W/O Duty Factor		10 log (N=2) dB	Duty Factor (dB)	Total PSD With Duty Factor (dBm/500kHz)	Limit (dBm/500kHz)	Pass / Fail
			(dBm/300kHz)	(dBm/500kHz)					
0	149	5745	-5.98	-3.76	3.01	0.19	-0.56	18.88	Pass
	157	5785	-5.52	-3.30	3.01	0.19	-0.10	18.88	Pass
	165	5825	-5.71	-3.49	3.01	0.19	-0.29	18.88	Pass
1	149	5745	-3.54	-1.32	3.01	0.19	1.88	18.88	Pass
	157	5785	-2.90	-0.68	3.01	0.19	2.52	18.88	Pass
	165	5825	-3.47	-1.25	3.01	0.19	1.95	18.88	Pass

Note:

1. Method E) 2) c) of power density measurement of KDB 662911 is using for calculating total power density, Measure and add $10 \log (N_{ANT})$ dB.
2. Directional gain = $14.11\text{dBi} + 10\log(2) = 17.12\text{dBi} > 6\text{dBi}$, so the power density limit shall be reduced to $30-(17.12-6) = 18.88\text{dBm}$.
3. Refer to section 3.3 for duty cycle spectrum plot.

802.11n (HT20)

TX chain	Chan.	Freq. (MHz)	PSD W/O Duty Factor		10 log (N=2) dB	Duty Factor (dB)	Total PSD With Duty Factor (dBm/500kHz)	Limit (dBm/500kHz)	Pass / Fail
			(dBm/300kHz)	(dBm/500kHz)					
0	149	5745	-5.78	-3.56	3.01	0.09	-0.46	18.88	Pass
	157	5785	-5.82	-3.60	3.01	0.09	-0.50	18.88	Pass
	165	5825	-5.78	-3.56	3.01	0.09	-0.46	18.88	Pass
1	149	5745	-3.08	-0.86	3.01	0.09	2.24	18.88	Pass
	157	5785	-3.22	-1.00	3.01	0.09	2.10	18.88	Pass
	165	5825	-3.62	-1.40	3.01	0.09	1.70	18.88	Pass

Note:

1. Method E) 2) c) of power density measurement of KDB 662911 is using for calculating total power density, Measure and add $10 \log (N_{ANT})$ dB.
2. Directional gain = $14.11\text{dBi} + 10\log(2) = 17.12\text{dBi} > 6\text{dBi}$, so the power density limit shall be reduced to $30-(17.12-6) = 18.88\text{dBm}$.
3. Refer to section 3.3 for duty cycle spectrum plot.

802.11n (HT40)

TX chain	Chan.	Freq. (MHz)	PSD W/O Duty Factor		10 log (N=2) dB	Duty Factor (dB)	Total PSD With Duty Factor (dBm/500kHz)	Limit (dBm/500kHz)	Pass / Fail
			(dBm/300kHz)	(dBm/500kHz)					
0	151	5755	-9.27	-7.05	3.01	0.16	-3.88	18.88	Pass
	159	5795	-8.81	-6.59	3.01	0.16	-3.42	18.88	Pass
1	151	5755	-6.79	-4.57	3.01	0.16	-1.40	18.88	Pass
	159	5795	-6.62	-4.40	3.01	0.16	-1.23	18.88	Pass

Note:

- Method E) 2) c) of power density measurement of KDB 662911 is using for calculating total power density, Measure and add $10 \log (N_{ANT})$ dB.
- Directional gain = $14.11\text{dBi} + 10\log(2) = 17.12\text{dBi} > 6\text{dBi}$, so the power density limit shall be reduced to $30 - (17.12 - 6) = 18.88\text{dBm}$.
- Refer to section 3.3 for duty cycle spectrum plot.

802.11ac (VHT80)

TX chain	Chan.	Freq. (MHz)	PSD W/O Duty Factor		10 log (N=2) dB	Duty Factor (dB)	Total PSD With Duty Factor (dBm/500kHz)	Limit (dBm/500kHz)	Pass / Fail
			(dBm/300kHz)	(dBm/500kHz)					
0	155	5775	-12.85	-10.63	3.01	0.27	-7.35	18.88	Pass
1	155	5775	-10.52	-8.30	3.01	0.27	-5.02	18.88	Pass

Note:

- Method E) 2) c) of power density measurement of KDB 662911 is using for calculating total power density, Measure and add $10 \log (N_{ANT})$ dB.
- Directional gain = $14.11\text{dBi} + 10\log(2) = 17.12\text{dBi} > 6\text{dBi}$, so the power density limit shall be reduced to $30 - (17.12 - 6) = 18.88\text{dBm}$.
- Refer to section 3.3 for duty cycle spectrum plot.

Spectrum Plot of Worst Value

802.11a

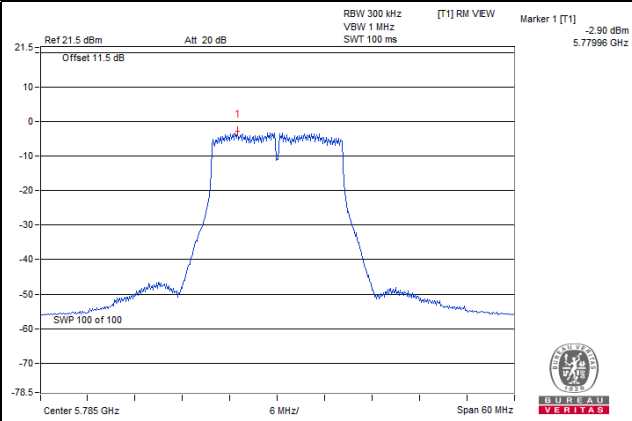

802.11n (HT20)

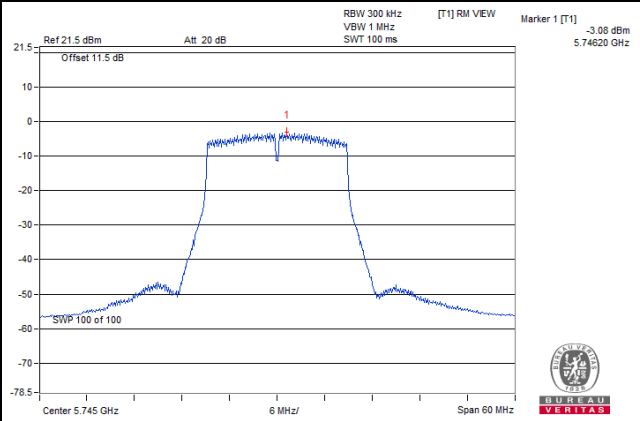

802.11n (HT40)

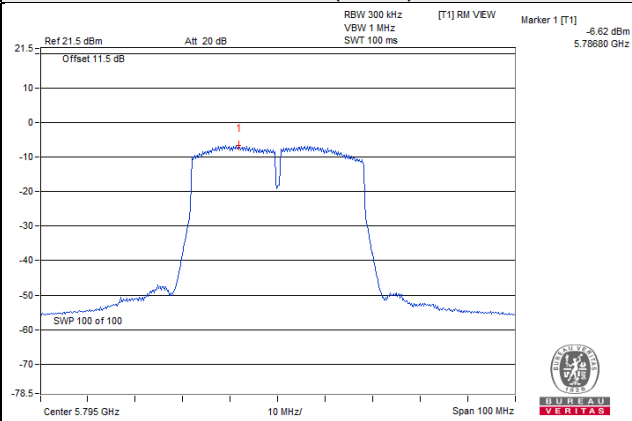

802.11ac (VHT80)

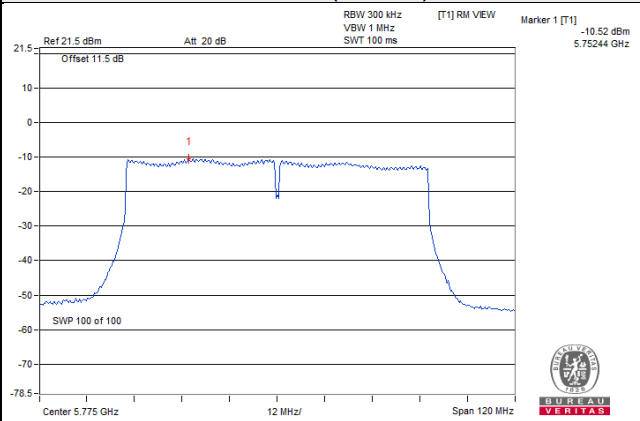

4.6 Frequency Stability

4.6.1 Limits of Frequency Stability Measurement

The frequency of the carrier signal shall be maintained within band of operation

4.6.2 Test Setup

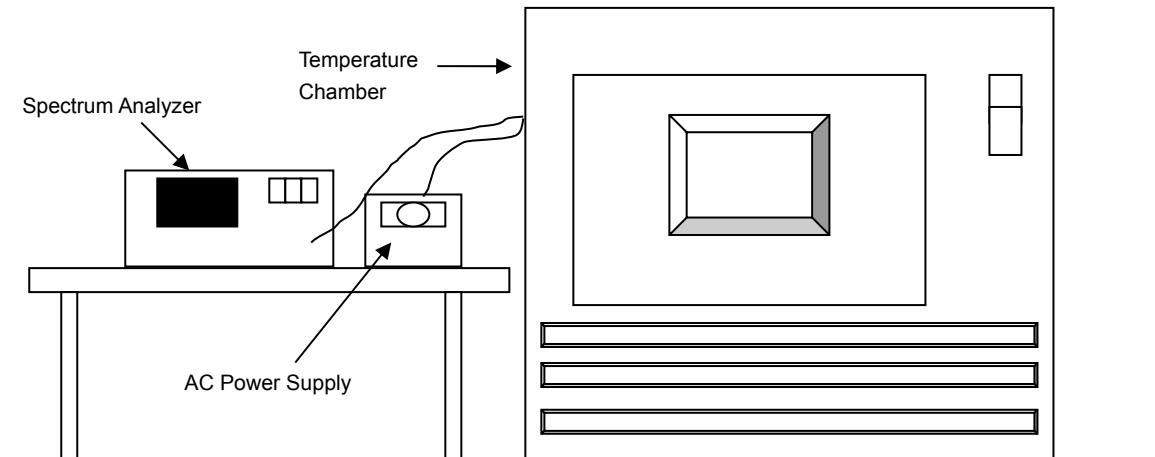

4.6.3 Test Instruments

Description & Manufacturer	Model No.	Serial No.	Cal. Date	Cal. Due
Spectrum Analyzer ROHDE & SCHWARZ	FSP40	100040	Sep. 25, 2018	Sep. 24, 2019
WIT Standard Temperature And Humidity Chamber	TH-4S-C	W981030	Jun. 03, 2019	Jun. 02, 2020
Digital Multimeter Fluke	87-III	70360742	Jun. 28, 2019	Jun. 27, 2020
AC Power Supply Extech	CFW-105	E000603	NA	NA

Note: 1. The calibration interval of the above test instruments is 12 months and the calibrations are traceable to NML/ROC and NIST/USA.

4.6.4 Test Procedure

- The EUT was placed inside the environmental test chamber and powered by nominal AC voltage.
- Turn the EUT on and couple its output to a spectrum analyzer.
- Turn the EUT off and set the chamber to the highest temperature specified.
- Allow sufficient time (approximately 30 min) for the temperature of the chamber to stabilize, turn the EUT on and measure the operating frequency after 2, 5, and 10 minutes.
- Repeat step (d) with the temperature chamber set to the next desired temperature until measurements down to the lowest specified temperature have been completed.
- The test chamber was allowed to stabilize at +20 degree C for a minimum of 30 minutes. The supply voltage was then adjusted on the EUT from 85% to 115% and the frequency record.

4.6.5 Deviation from Test Standard

No deviation.

4.6.6 EUT Operating Condition

Set the EUT transmit at un-modulation mode to test frequency stability.

4.6.7 Test Results

Frequency Stability Versus Temp.									
Operating Frequency: 5180MHz									
Temp. (°C)	Power Supply (Vac)	0 Minute		2 Minute		5 Minute		10 Minute	
		Measured Frequency (MHz)	Result	Measured Frequency (MHz)	Result	Measured Frequency (MHz)	Result	Measured Frequency (MHz)	Result
60	120	5179.9978	Pass	5179.9945	Pass	5179.9936	Pass	5179.9929	Pass
50	120	5180.0117	Pass	5180.0114	Pass	5180.0128	Pass	5180.0148	Pass
40	120	5180.0207	Pass	5180.0211	Pass	5180.0179	Pass	5180.0216	Pass
30	120	5179.9825	Pass	5179.9794	Pass	5179.9815	Pass	5179.9804	Pass
20	120	5179.9848	Pass	5179.9847	Pass	5179.9848	Pass	5179.9808	Pass
10	120	5179.984	Pass	5179.9802	Pass	5179.9807	Pass	5179.9835	Pass
0	120	5179.991	Pass	5179.9924	Pass	5179.9896	Pass	5179.9929	Pass
-10	120	5180.0144	Pass	5180.0152	Pass	5180.016	Pass	5180.0135	Pass
-20	120	5179.9762	Pass	5179.9804	Pass	5179.9799	Pass	5179.9775	Pass

Frequency Stability Versus Voltage									
Operating Frequency: 5180MHz									
Temp. (°C)	Power Supply (Vac)	0 Minute		2 Minute		5 Minute		10 Minute	
		Measured Frequency (MHz)	Result	Measured Frequency (MHz)	Result	Measured Frequency (MHz)	Result	Measured Frequency (MHz)	Result
20	138	5179.9847	Pass	5179.9853	Pass	5179.9851	Pass	5179.9818	Pass
	120	5179.9848	Pass	5179.9847	Pass	5179.9848	Pass	5179.9808	Pass
	102	5179.985	Pass	5179.9852	Pass	5179.9841	Pass	5179.9806	Pass

4.7 6dB Bandwidth Measurement

4.7.1 Limits of 6dB Bandwidth Measurement

The minimum of 6dB Bandwidth Measurement is 0.5MHz.

4.7.2 Test Setup



4.7.3 Test Instruments

Refer to section 4.1.2 to get information of above instrument.

4.7.4 Test Procedure

- Set resolution bandwidth (RBW) = 100kHz
- Set the video bandwidth (VBW) $\geq 3 \times$ RBW, Detector = Peak.
- Trace mode = max hold.
- Sweep = auto couple.
- Measure the maximum width of the emission that is constrained by the frequencies associated with the two amplitude points (upper and lower) that are attenuated by 6 dB relative to the maximum level measured in the fundamental emission

4.7.5 Deviation from Test Standard

No deviation.

4.7.6 EUT Operating Condition

The software provided by client to enable the EUT under transmission condition continuously at lowest, middle and highest channel frequencies individually.

4.7.7 Test Results

802.11a

Channel	Frequency (MHz)	6dB Bandwidth (MHz)		Minimum Limit (MHz)	Pass / Fail
		Chain 0	Chain 1		
149	5745	16.39	16.42	0.5	Pass
157	5785	16.38	16.36	0.5	Pass
165	5825	16.39	16.41	0.5	Pass

802.11n (HT20)

Channel	Frequency (MHz)	6dB Bandwidth (MHz)		Minimum Limit (MHz)	Pass / Fail
		Chain 0	Chain 1		
149	5745	17.25	16.60	0.5	Pass
157	5785	17.62	16.61	0.5	Pass
165	5825	17.29	17.63	0.5	Pass

802.11n (HT40)

Channel	Frequency (MHz)	6dB Bandwidth (MHz)		Minimum Limit (MHz)	Pass / Fail
		Chain 0	Chain 1		
151	5755	35.19	35.26	0.5	Pass
159	5795	35.24	35.26	0.5	Pass

802.11ac (VHT80)

Channel	Frequency (MHz)	6dB Bandwidth (MHz)		Minimum Limit (MHz)	Pass / Fail
		Chain 0	Chain 1		
155	5775	76.07	76.08	0.5	Pass

Spectrum Plot of Worst Value

802.11a

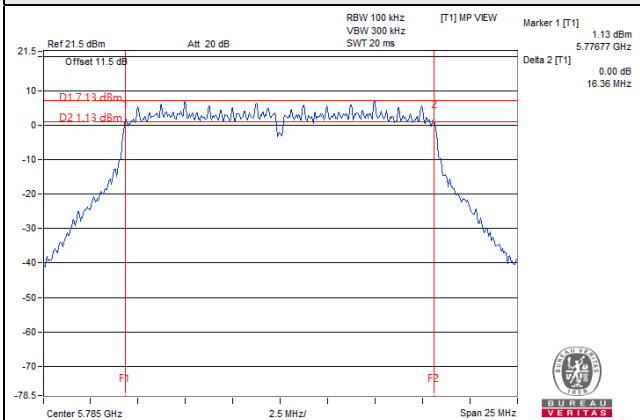

802.11n (HT20)

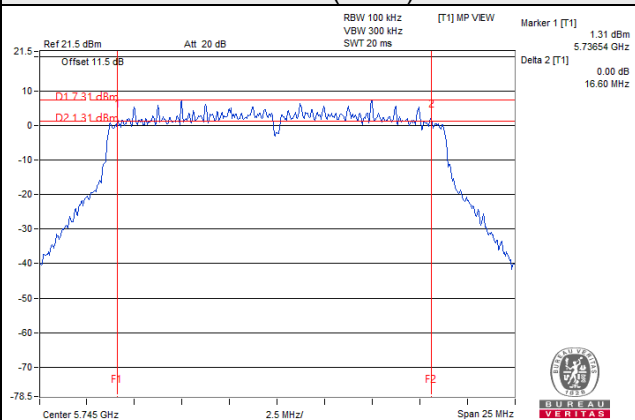

802.11n (HT40)

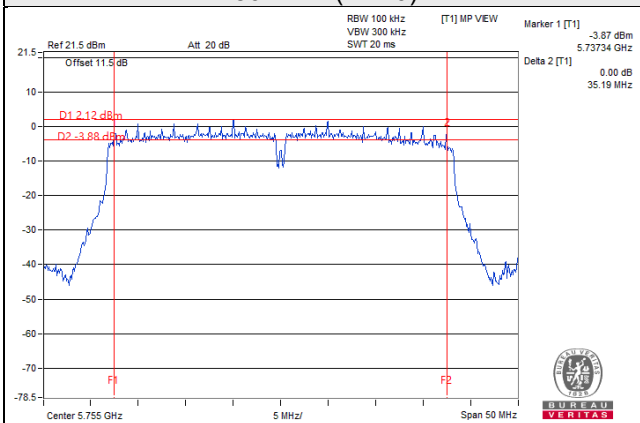

802.11ac (VHT80)

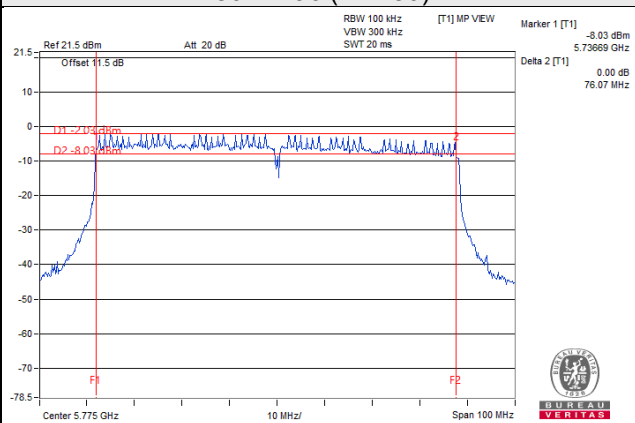

5 Pictures of Test Arrangements

Please refer to the attached file (Test Setup Photo).

Annex A- Radiated Out of Band Emission (OOBE) Measurement (For U-NII-3 band)

802.11a

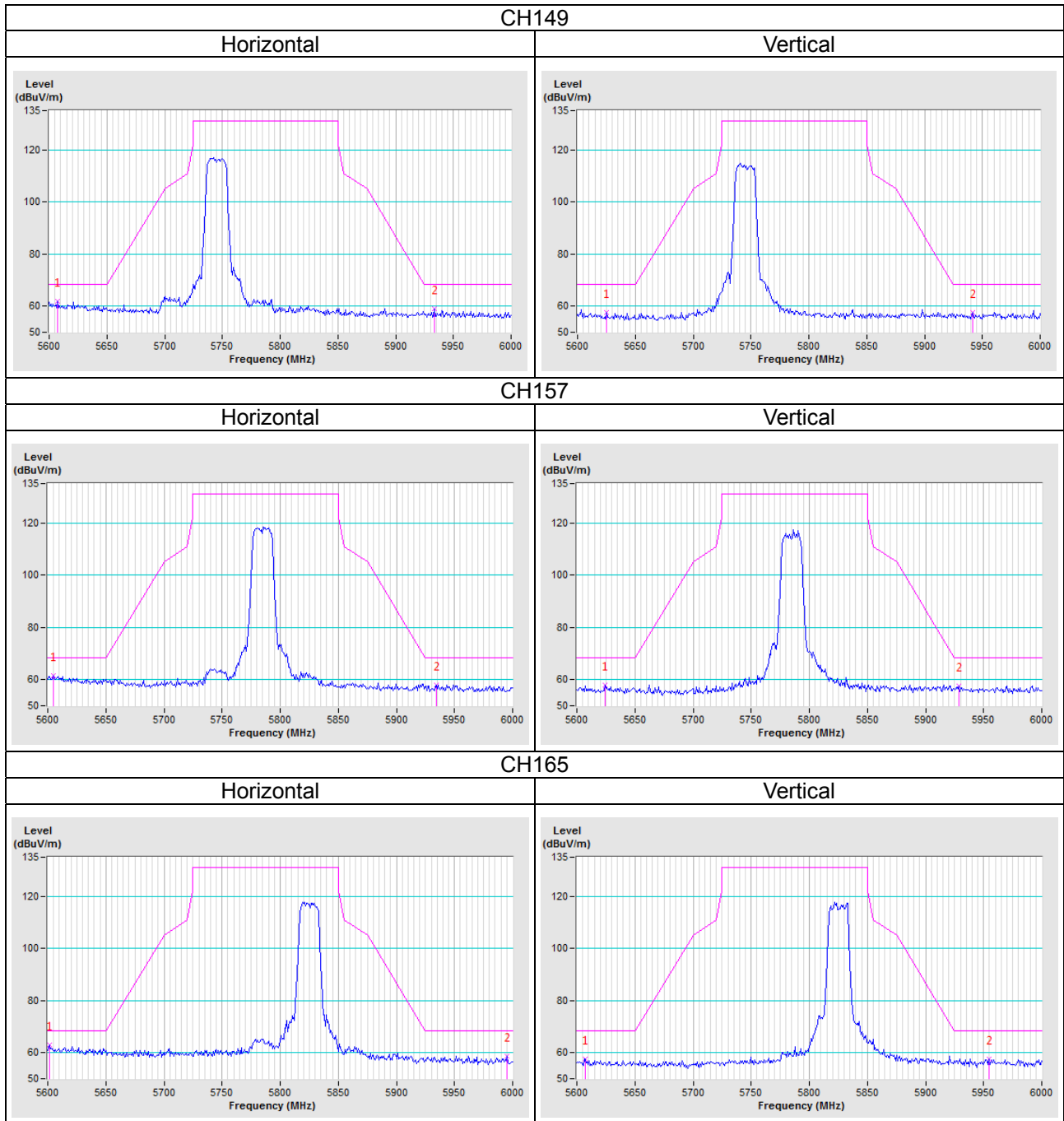

802.11n (HT20)

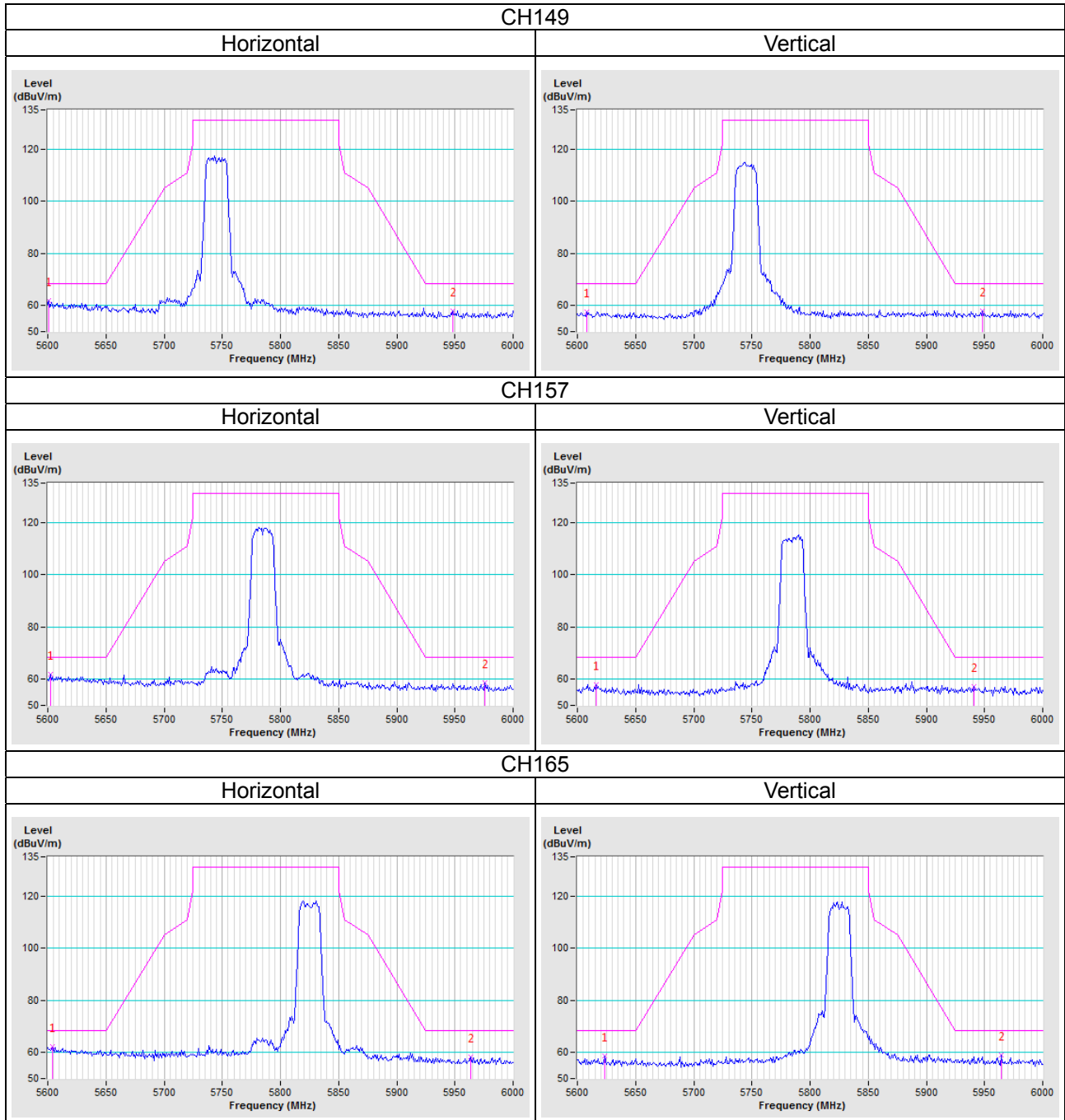

802.11n (HT40)

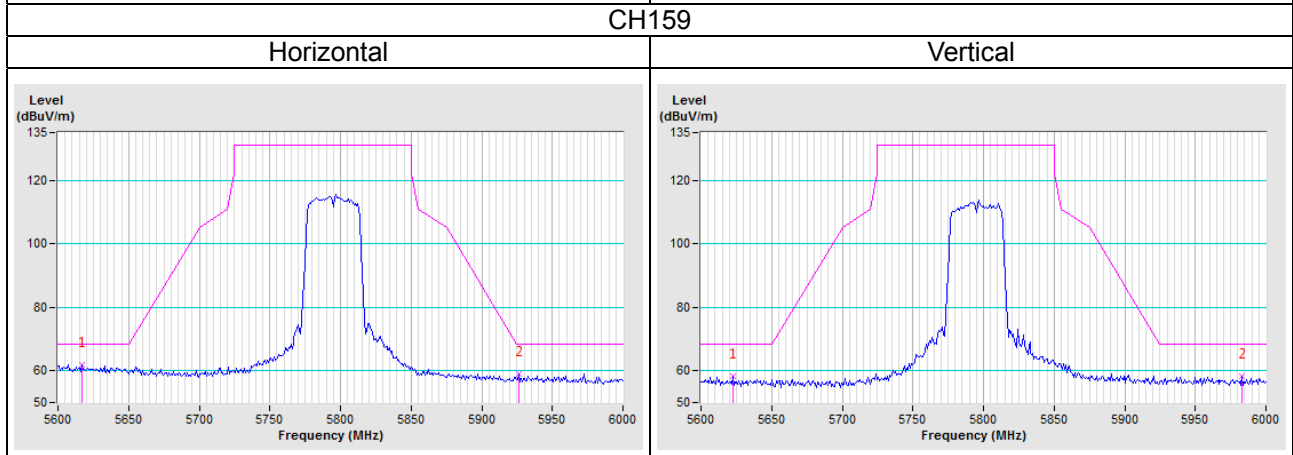
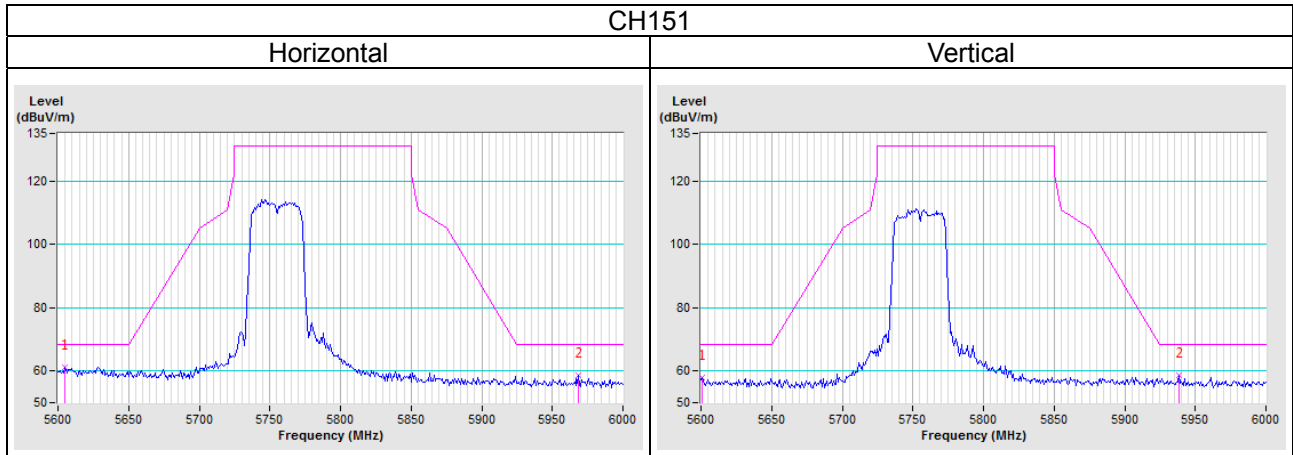

802.11ac (VHT80)

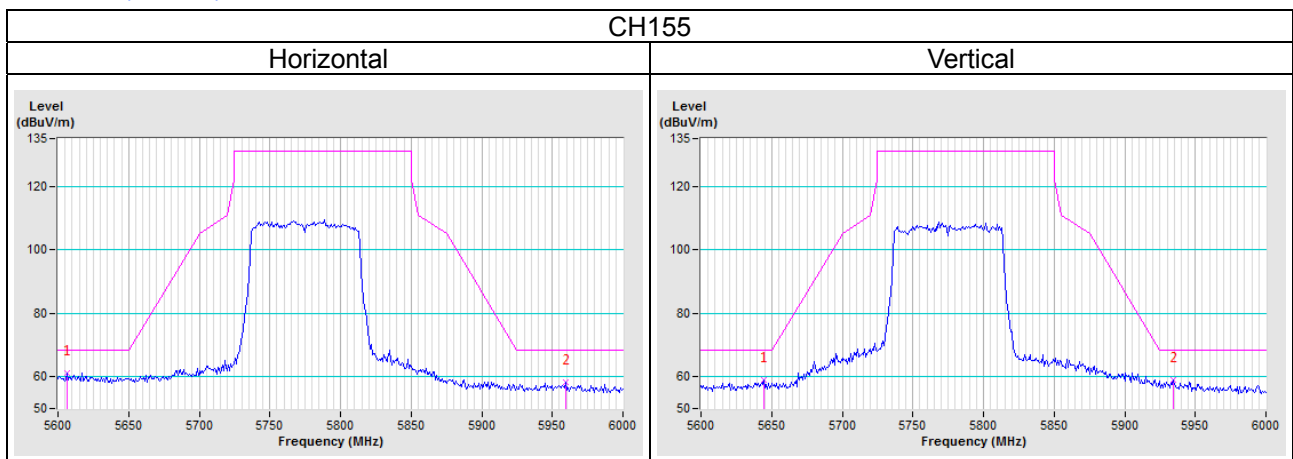

Appendix – Information of the Testing Laboratories

We, Bureau Veritas Consumer Products Services (H.K.) Ltd., Taoyuan Branch, were founded in 1988 to provide our best service in EMC, Radio, Telecom and Safety consultation. Our laboratories are FCC recognized accredited test firms and accredited and approved according to ISO/IEC 17025.

If you have any comments, please feel free to contact us at the following:

Lin Kou EMC/RF Lab

Tel: 886-2-26052180

Fax: 886-2-26051924

Hsin Chu EMC/RF/Telecom Lab

Tel: 886-3-6668565

Fax: 886-3-6668323

Hwa Ya EMC/RF/Safety

Tel: 886-3-3183232

Fax: 886-3-3270892

Email: service.adt@tw.bureauveritas.com

Web Site: www.bureauveritas-adt.com

The address and road map of all our labs can be found in our web site also.

--- END ---