



# FCC TEST REPORT (15.407)

**REPORT NO.:** RF131230C23-1  
**MODEL NO.:** EAP900H, EWS320AP  
**FCC ID:** A8J-EAP900H  
**RECEIVED:** Nov. 26, 2013  
**TESTED:** Nov. 27, 2013 ~ Jan. 16, 2014  
**ISSUED:** Jan. 24, 2014

**APPLICANT:** EnGenius Technologies

**ADDRESS:** 1580 Scenic Avenue, Costa Mesa, CA92626

**ISSUED BY:** Bureau Veritas Consumer Products Services  
(H.K.) Ltd., Taoyuan Branch

**LAB ADDRESS:** No. 47, 14th Ling, Chia Pau Vil., Lin Kou Dist.,  
New Taipei City, Taiwan, R.O.C.

**TEST LOCATION:** No. 19, Hwa Ya 2nd Rd, Wen Hwa Tsuen, Kwei  
Shan Hsiang, Taoyuan Hsien 333, Taiwan, R.O.C.

This report should not be used by the client to claim product certification, approval, or endorsement by TAF or any government agencies.



This report is for your exclusive use. Any copying or replication of this report to or for any other person or entity, or use of our name or trademark, is permitted only with our prior written permission. This report sets forth our findings solely with respect to the test samples identified herein. The results set forth in this report are not indicative or representative of the quality or characteristics of the lot from which a test sample was taken or any similar or identical product unless specifically and expressly noted. Our report includes all of the tests requested by you and the results thereof based upon the information that you provided to us. You have 60 days from date of issuance of this report to notify us of any material error or omission caused by our negligence, provided, however, that such notice shall be in writing and shall specifically address the issue you wish to raise. A failure to raise such issue within the prescribed time shall constitute your unqualified acceptance of the completeness of this report, the tests conducted and the correctness of the report contents. Unless specific mention, the uncertainty of measurement has been explicitly taken into account to declare the compliance or non-compliance to the specification.



## TABLE OF CONTENTS

RELEASE CONTROL RECORD.....	4
1. CERTIFICATION.....	5
2. SUMMARY OF TEST RESULTS .....	6
2.1 MEASUREMENT UNCERTAINTY.....	6
3. GENERAL INFORMATION.....	7
3.1 GENERAL DESCRIPTION OF EUT .....	7
3.2 DESCRIPTION OF TEST MODES .....	9
3.2.1 TEST MODE APPLICABILITY AND TESTED CHANNEL DETAIL .....	10
3.3 DUTY CYCLE OF TEST SIGNAL.....	12
3.4 DESCRIPTION OF SUPPORT UNITS .....	16
3.4.1 CONFIGURATION OF SYSTEM UNDER TEST .....	17
3.5 GENERAL DESCRIPTION OF APPLIED STANDARDS .....	18
4. TEST TYPES AND RESULTS .....	19
4.1 RADIATED EMISSION AND BANDEDGE MEASUREMENT .....	19
4.1.1 LIMITS OF RADIATED EMISSION AND BANDEDGE MEASUREMENT .....	19
4.1.2 LIMITS OF UNWANTED EMISSION OUT OF THE RESTRICTED BANDS .....	19
4.1.3 TEST INSTRUMENTS.....	20
4.1.4 TEST PROCEDURES .....	21
4.1.5 DEVIATION FROM TEST STANDARD .....	21
4.1.6 TEST SETUP.....	22
4.1.7 EUT OPERATING CONDITION.....	23
4.1.8 TEST RESULTS .....	24
4.2 CONDUCTED EMISSION MEASUREMENT .....	34
4.2.1 LIMITS OF CONDUCTED EMISSION MEASUREMENT .....	34
4.2.2 TEST INSTRUMENTS.....	34
4.2.3 TEST PROCEDURES .....	35
4.2.4 DEVIATION FROM TEST STANDARD .....	35
4.2.5 TEST SETUP.....	35
4.2.6 EUT OPERATING CONDITIONS .....	35
4.2.7 TEST RESULTS .....	36
4.3 PEAK TRANSMIT POWER MEASUREMENT .....	40
4.3.1 LIMITS OF PEAK TRANSMIT POWER MEASUREMENT .....	40
4.3.2 TEST SETUP.....	40
4.3.3 TEST INSTRUMENTS.....	40
4.3.4 TEST PROCEDURE.....	41



A D T

4.3.5	DEVIATION FROM TEST STANDARD .....	41
4.3.6	EUT OPERATING CONDITIONS .....	41
4.3.7	TEST RESULTS .....	42
4.4	PEAK POWER SPECTRAL DENSITY MEASUREMENT .....	46
4.4.1	LIMITS OF PEAK POWER SPECTRAL DENSITY MEASUREMENT .....	46
4.4.2	TEST SETUP .....	46
4.4.3	TEST INSTRUMENTS.....	46
4.4.4	TEST PROCEDURES .....	46
4.4.5	DEVIATION FROM TEST STANDARD .....	46
4.4.6	EUT OPERATING CONDITIONS .....	46
4.4.7	TEST RESULTS .....	47
4.5	PEAK POWER EXCURSION MEASUREMENT .....	50
4.5.1	LIMITS OF PEAK POWER EXCURSION MEASUREMENT .....	50
4.5.2	TEST SETUP .....	50
4.5.3	TEST INSTRUMENTS.....	50
4.5.4	TEST PROCEDURE.....	50
4.5.5	DEVIATION FROM TEST STANDARD .....	51
4.5.6	EUT OPERATING CONDITIONS .....	51
4.5.7	TEST RESULTS .....	52
4.6	FREQUENCY STABILITY.....	53
4.6.1	LIMITS OF FREQUENCY STABILITY MEASUREMENT .....	53
4.6.2	TEST SETUP .....	53
4.6.3	TEST INSTRUMENTS.....	53
4.6.4	TEST PROCEDURE.....	54
4.6.5	DEVIATION FROM TEST STANDARD .....	54
4.6.6	EUT OPERATING CONDITION.....	54
4.6.7	TEST RESULTS .....	55
5.	PHOTOGRAPHS OF THE TEST CONFIGURATION.....	56
6.	INFORMATION ON THE TESTING LABORATORIES .....	57
7.	APPENDIX A – MODIFICATIONS RECORDERS FOR ENGINEERING CHANGES TO THE EUT BY THE LAB.....	58



A D T

## RELEASE CONTROL RECORD

ISSUE NO.	REASON FOR CHANGE	DATE ISSUED
RF131230C23-1	Original release	Jan. 24, 2014



# 1. CERTIFICATION

**PRODUCT:** Dual Band N900 Access Point

**MODEL:** EAP900H, EWS320AP

**BRAND:** EnGenius

**APPLICANT:** EnGenius Technologies

**TESTED:** Nov. 27, 2013 ~ Jan. 16, 2014

**TEST SAMPLE:** ENGINEERING SAMPLE

**STANDARDS: FCC Part 15, Subpart E (Section 15.407)**

ANSI C63.10-2009

The above equipment (model: EAP900H) has been tested by **Bureau Veritas Consumer Products Services (H.K.) Ltd., Taoyuan Branch**, and found compliance with the requirement of the above standards. The test record, data evaluation & Equipment Under Test (EUT) configurations represented herein are true and accurate accounts of the measurements of the sample's EMC characteristics under the conditions specified in this report.

**PREPARED BY :** Celine Chou , **DATE :** Jan. 24, 2014  
Celine Chou / Specialist

**APPROVED BY :** Ken Liu , **DATE :** Jan. 24, 2014  
Ken Liu / Senior Manager

## 2. SUMMARY OF TEST RESULTS

The EUT has been tested according to the following specifications:

APPLIED STANDARD: FCC PART 15, SUBPART E (SECTION 15.407)			
STANDARD SECTION	TEST TYPE	RESULT	REMARK
15.407(b)(6)	AC Power Conducted Emission	PASS	Meet the requirement of limit. Minimum passing margin is -7.72dB at 0.46669MHz.
15.407(b/1/2/3)(b)(6)	Radiated Emissions	PASS	Meet the requirement of limit. Minimum passing margin is -2.5dB at 728.44MHz.
15.407(a/1/2)	Max Average Transmit Power	PASS	Meet the requirement of limit.
15.407(a)(6)	Peak Power Excursion	PASS	Meet the requirement of limit.
15.407(a/1/2)	Peak Power Spectral Density	PASS	Meet the requirement of limit.
15.407(g)	Frequency Stability	PASS	Meet the requirement of limit.
15.203	Antenna Requirement	PASS	Antenna connector is IPEX not a standard connector.

### 2.1 MEASUREMENT UNCERTAINTY

Where relevant, the following measurement uncertainty levels have been estimated for tests performed on the EUT as specified in CISPR 16-4-2:

MEASUREMENT	FREQUENCY	UNCERTAINTY
Conducted emissions	9kHz~30MHz	2.44 dB
Radiated emissions	30MHz ~ 200MHz	3.34 dB
	200MHz ~1000MHz	3.35 dB
	1GHz ~ 18GHz	2.26 dB
	18GHz ~ 40GHz	1.94 dB

This uncertainty represents an expanded uncertainty expressed at approximately the 95% confidence level using a coverage factor of  $k = 2$ .

### 3. GENERAL INFORMATION

#### 3.1 GENERAL DESCRIPTION OF EUT

<b>EUT</b>	Dual Band N900 Access Point
<b>MODEL NO.</b>	EAP900H, EWS320AP
<b>POWER SUPPLY</b>	12Vdc (Adapter) 48Vdc (PoE)
<b>MODULATION TYPE</b>	64QAM, 16QAM, QPSK, BPSK
<b>MODULATION TECHNOLOGY</b>	OFDM
<b>TRANSFER RATE</b>	802.11a: 54.0/ 48.0/ 36.0/ 24.0/ 18.0/ 12.0/ 9.0/ 6.0Mbps 802.11n: up to 450.0Mbps
<b>OPERATING FREQUENCY</b>	5180 ~ 5240MHz
<b>NUMBER OF CHANNEL</b>	4 for 802.11a, 802.11n (20MHz) 2 for 802.11n (40MHz)
<b>OUTPUT POWER</b>	49.430mW
<b>ANTENNA TYPE</b>	PIFA antenna with 5.0dBi gain
<b>ANTENNA CONNECTOR</b>	IPEX
<b>DATA CABLE</b>	N/A
<b>I/O PORTS</b>	Refer to user's manual
<b>ACCESSORY DEVICES</b>	Adapter

**NOTE:**

- The models as below are identical to each other except for their outward appearance due to marketing purpose.

BRAND	MODEL
EnGenius	EAP900H
	EWS320AP

\* The model of the EAP900H was chosen for final test.

- The EUT incorporates a MIMO function. Physically, the EUT provides 3 completed transmitters and 3 receivers.

MODULATION MODE	TX FUNCTION
802.11b	3TX
802.11g	3TX
802.11a	3TX
802.11n (20MHz) MCS 0-7	1TX
802.11n (20MHz) MCS 8-15	2TX
802.11n (20MHz) MCS 16-23	3TX
802.11n (40MHz) MCS 0-7	1TX
802.11n (40MHz) MCS 8-15	2TX
802.11n (40MHz) MCS 16-23	3TX

3. The EUT consumes power from the following adapter and POE.

<b>ADAPTER</b>	
<b>BRAND:</b>	Powertron Electronics Corp.
<b>MODEL:</b>	PA1024-2HUB PA1024-2HU PA1024-120HUB200
<b>INPUT:</b>	100-240Vac, 50-60Hz, 0.6A
<b>OUTPUT:</b>	12Vdc, 2.0A, 24W Max
<b>POWER LINE:</b>	1.5m cable with 1 core attached on adapter

<b>ADAPTER FOR POE (SUPPORT UNIT)</b>	
<b>BRAND:</b>	Powertron Electronics Corp.
<b>MODEL:</b>	PA1040-480IB080
<b>INPUT:</b>	100-240Vac, 50-60Hz, 1.5A
<b>OUTPUT:</b>	48Vdc, 0.8A, 38.4W Max
<b>POWER LINE:</b>	1.5m cable with 1 core attached on adapter

<b>POE (SUPPORT UNIT)</b>	
<b>BRAND:</b>	EnGenius
<b>MODEL:</b>	NPE-7530G
<b>POWER RATING:</b>	48Vdc

4. The above EUT information was declared by the manufacturer and for more detailed features description, please refer to the manufacturer's specifications or User's Manual.



### 3.2 DESCRIPTION OF TEST MODES

4 channels are provided for 802.11a, 802.11n (20MHz):

CHANNEL	FREQUENCY	CHANNEL	FREQUENCY
36	5180MHz	44	5220MHz
40	5200MHz	48	5240MHz

2 channels are provided for 802.11n (40MHz):

CHANNEL	FREQUENCY	CHANNEL	FREQUENCY
38	5190MHz	46	5230MHz

### 3.2.1 TEST MODE APPLICABILITY AND TESTED CHANNEL DETAIL

EUT CONFIGURE MODE	APPLICABLE TO				DESCRIPTION
	RE $\geq$ 1G	RE<1G	PLC	APCM	
A	√	√	√	√	Power from adapter
B	-	√	-	-	Power from POE

Where **RE $\geq$ 1G**: Radiated Emission above 1GHz      **RE<1G**: Radiated Emission below 1GHz  
**PLC**: Power Line Conducted Emission      **APCM**: Antenna Port Conducted Measurement

**NOTE:**

1. The EUT had been pre-tested on the positioned of each 3 axis. The worst case was found when positioned on **X-plane**.
2. "-" means no effect.

**RADIATED EMISSION TEST (ABOVE 1GHz):**

- Pre-Scan has been conducted to determine the worst-case mode from all possible combinations between available modulations, data rates and antenna ports (if EUT with antenna diversity architecture).
- Following channel(s) was (were) selected for the final test as listed below.

EUT CONFIGURE MODE	MODE	AVAILABLE CHANNEL	TESTED CHANNEL	MODULATION TECHNOLOGY	MODULATION TYPE	DATA RATE (Mbps)
A	802.11a	36 to 48	36, 40, 48	OFDM	BPSK	6.0
A	802.11n (20MHz)	36 to 48	36, 40, 48	OFDM	BPSK	7.2
A	802.11n (40MHz)	38 to 46	38, 46	OFDM	BPSK	15.0

**RADIATED EMISSION TEST (BELOW 1GHz):**

- Pre-Scan has been conducted to determine the worst-case mode from all possible combinations between available modulations, data rates and antenna ports (if EUT with antenna diversity architecture).
- Following channel(s) was (were) selected for the final test as listed below.

EUT CONFIGURE MODE	MODE	AVAILABLE CHANNEL	TESTED CHANNEL	MODULATION TECHNOLOGY	MODULATION TYPE	DATA RATE (Mbps)
A & B	802.11a	36 to 48	36	OFDM	BPSK	6.0

**POWER LINE CONDUCTED EMISSION TEST:**

- Pre-Scan has been conducted to determine the worst-case mode from all possible combinations between available modulations, data rates and antenna ports (if EUT with antenna diversity architecture).
- Following channel(s) was (were) selected for the final test as listed below.

EUT CONFIGURE MODE	MODE	AVAILABLE CHANNEL	TESTED CHANNEL	MODULATION TECHNOLOGY	MODULATION TYPE	DATA RATE (Mbps)
A & B	802.11a	36 to 48	36	OFDM	BPSK	6.0

**ANTENNA PORT CONDUCTED MEASUREMENT:**

- This item includes all test value of each mode, but only includes spectrum plot of worst value of each mode.
- Pre-Scan has been conducted to determine the worst-case mode from all possible combinations between available modulations, data rates and antenna ports (if EUT with antenna diversity architecture).
- Following channel(s) was (were) selected for the final test as listed below.

EUT CONFIGURE MODE	MODE	AVAILABLE CHANNEL	TESTED CHANNEL	MODULATION TECHNOLOGY	MODULATION TYPE	DATA RATE (Mbps)
A	802.11a	36 to 48	36, 40, 48	OFDM	BPSK	6.0
A	802.11n (20MHz)	36 to 48	36, 40, 48	OFDM	BPSK	7.2
A	802.11n (40MHz)	38 to 46	38, 46	OFDM	BPSK	15.0

**TEST CONDITION:**

APPLICABLE TO	ENVIRONMENTAL CONDITIONS	INPUT POWER	TESTED BY
RE $\geq$ 1G	25deg. C, 65%RH	120Vac, 60Hz	Ted Chang
RE<1G	25deg. C, 65%RH	120Vac, 60Hz 48Vdc	Ted Chang
PLC	25deg. C, 65%RH	120Vac, 60Hz 48Vdc	Chris Lin
APCM	25deg. C, 60%RH	120Vac, 60Hz	Ted Chang

### 3.3 DUTY CYCLE OF TEST SIGNAL

#### MODULATION TYPE: BPSK

Duty cycle of test signal is < 98 %, duty factor is required

**802.11a:** Duty cycle =  $2.022/2.069 = 0.977$ , Duty factor =  $10 * \log(1/0.977) = 0.10$

**802.11n (20MHz):** Duty cycle =  $0.667/0.712 = 0.937$ , Duty factor =  $10 * \log(1/0.937) = 0.28$

**802.11n (40MHz):** Duty cycle =  $0.345/0.380 = 0.908$ , Duty factor =  $10 * \log(1/0.908) = 0.42$

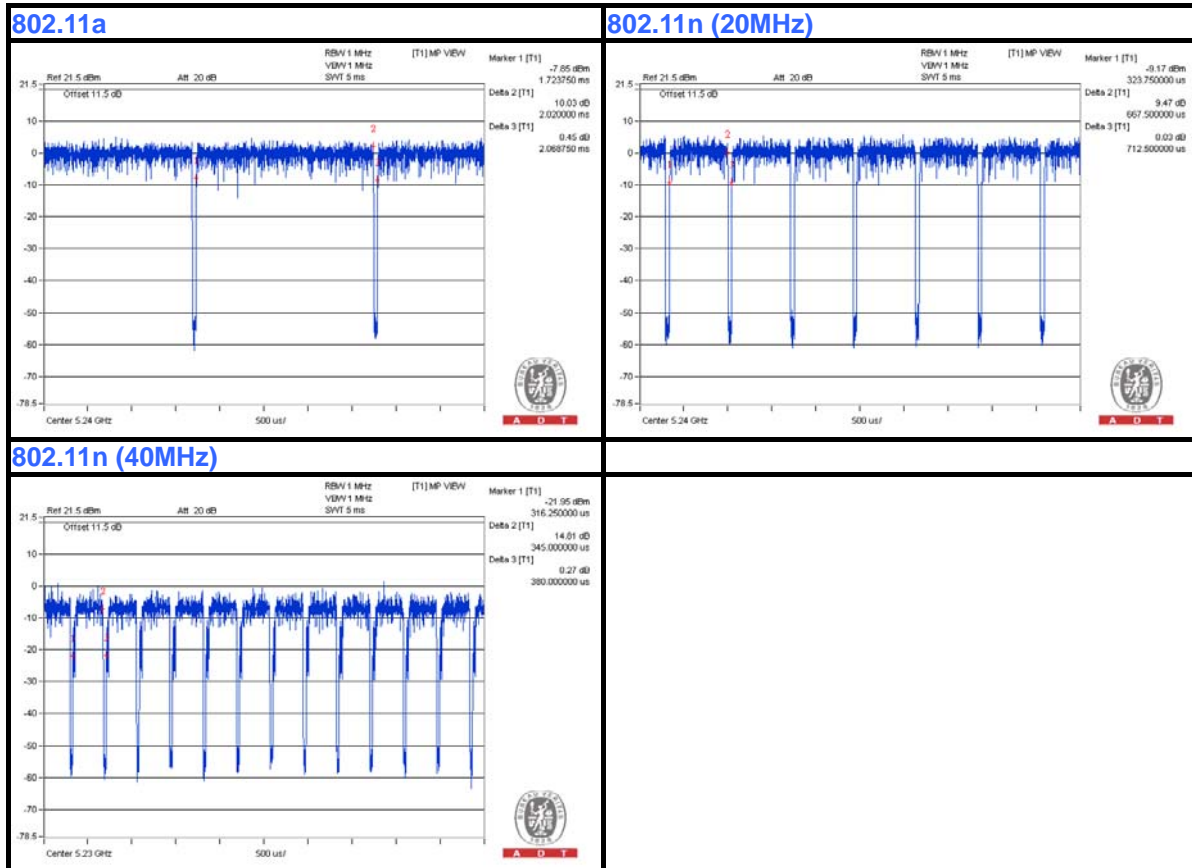



### MODULATION TYPE: QPSK

Duty cycle of test signal is < 98 %, duty factor is required

**802.11a:** Duty cycle =  $1.024/1.069 = 0.958$ , Duty factor =  $10 * \log( 1/0.958 ) = 0.19$

**802.11n (20MHz):** Duty cycle =  $0.358/0.404 = 0.886$ , Duty factor =  $10 * \log( 1/0.886 ) = 0.52$

**802.11n (40MHz):** Duty cycle =  $0.197/0.231 = 0.853$ , Duty factor =  $10 * \log( 1/0.853 ) = 0.69$

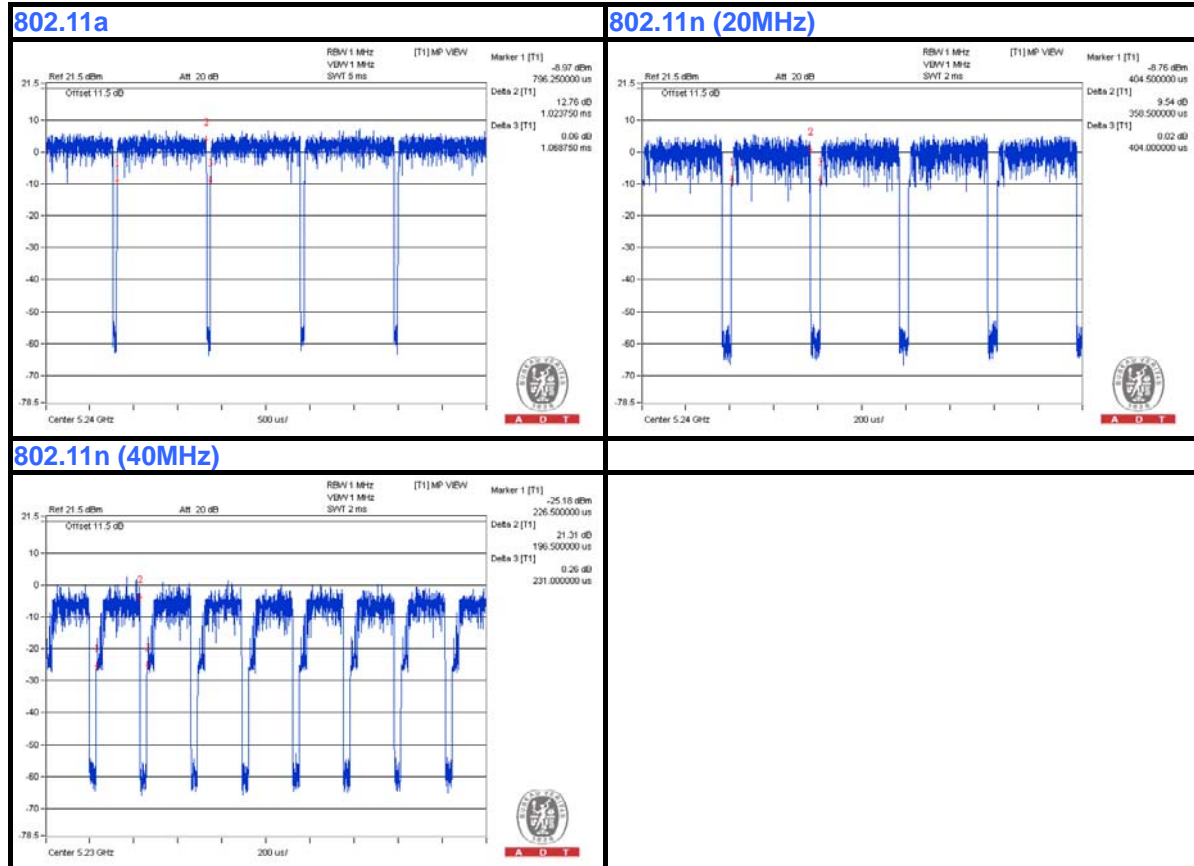



A D T

### MODULATION TYPE: 16QAM

Duty cycle of test signal is < 98 %, duty factor is required

**802.11a:** Duty cycle =  $0.522/0.569 = 0.917$ , Duty factor =  $10 * \log(1/0.917) = 0.37$

**802.11n (20MHz):** Duty cycle =  $0.203/0.248 = 0.819$ , Duty factor =  $10 * \log(1/0.819) = 0.87$

**802.11n (40MHz):** Duty cycle =  $0.122/0.156 = 0.782$ , Duty factor =  $10 * \log(1/0.782) = 1.07$

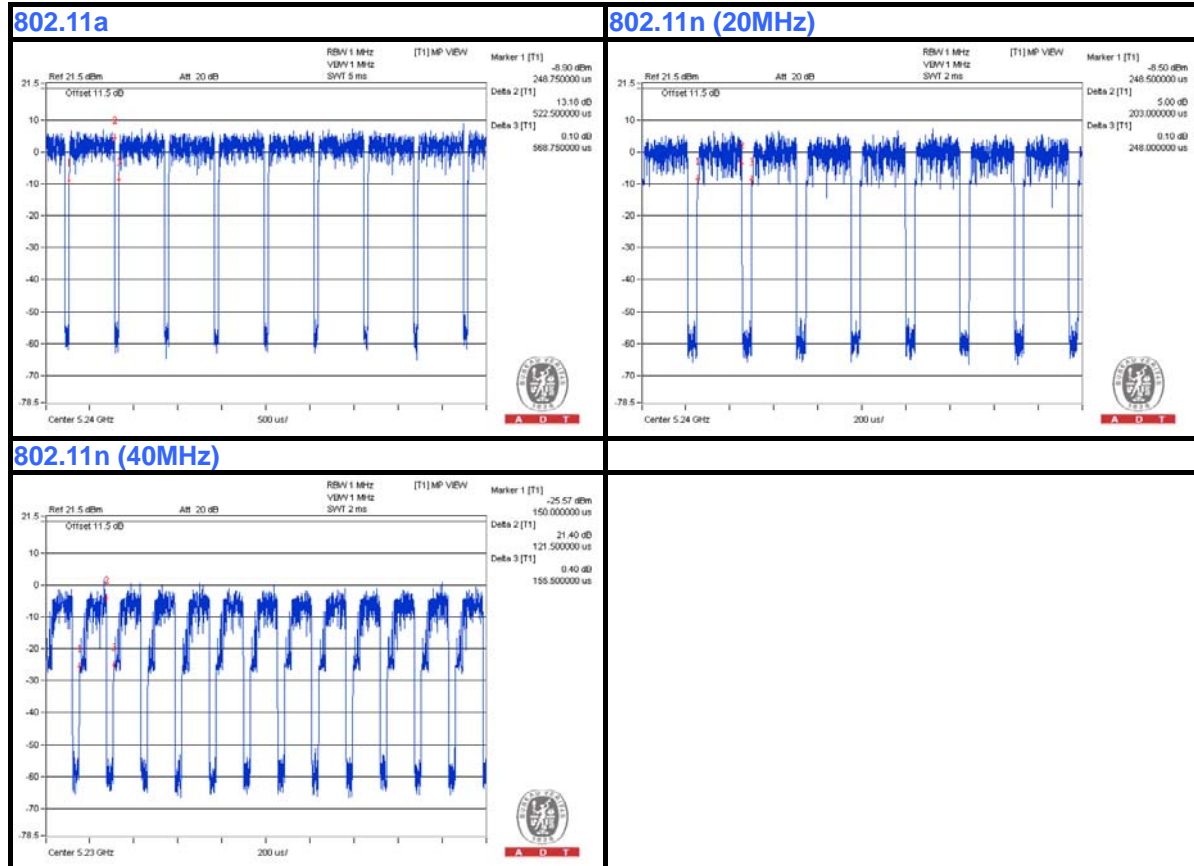



A D T

### MODULATION TYPE: 64QAM

Duty cycle of test signal is < 98 %, duty factor is required

**802.11a:** Duty cycle =  $0.270/0.316 = 0.854$ , Duty factor =  $10 * \log(1/0.854) = 0.68$

**802.11n (20MHz):** Duty cycle =  $0.127/0.172 = 0.738$ , Duty factor =  $10 * \log(1/0.738) = 1.32$

**802.11n (40MHz):** Duty cycle =  $0.084/0.120 = 0.707$ , Duty factor =  $10 * \log(1/0.707) = 1.55$

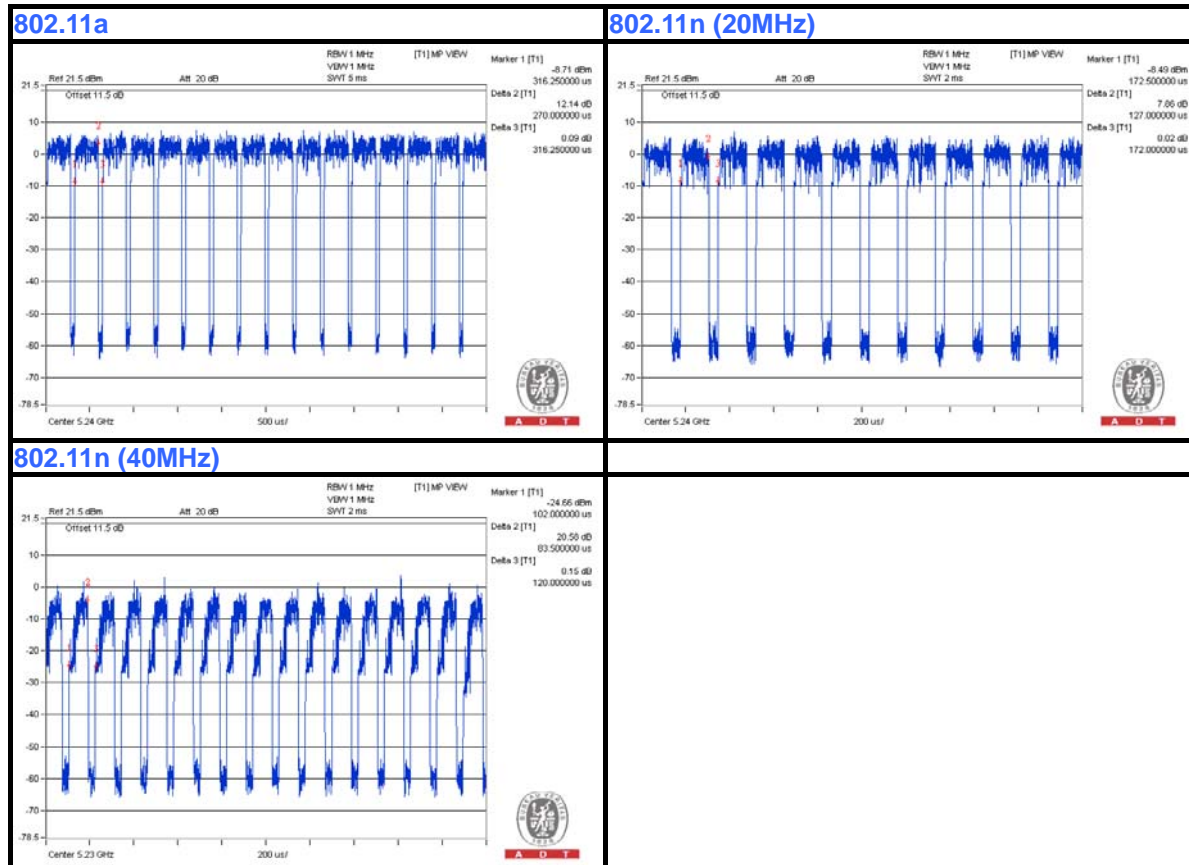

### 3.4 DESCRIPTION OF SUPPORT UNITS

The EUT has been tested as an independent unit together with other necessary accessories or support units. The following support units or accessories were used to form a representative test configuration during the tests.

NO.	PRODUCT	BRAND	MODEL NO.	SERIAL NO.	FCC ID
1	NOTEBOOK	DELL	D531	CN-0XM006-4864 3-81U-2610	QDS-BRCM1020
2	POE	EnGenius	NPE-7530G	NA	NA
3	ADAPTER	Powertron Electronics Corp.	PA1040-480IB080	NA	NA

NO.	SIGNAL CABLE DESCRIPTION OF THE ABOVE SUPPORT UNITS
1	10m RJ45 UTP cable for test mode A, 1.8m RJ45 UTP cable for test mode B
2	10m RJ45 UTP cable
3	NA

**NOTE:**

1. All power cords of the above support units are non-shielded (1.8 m).
2. Item 1 acted as a communication partner to transfer data.
3. Items 2-3 were provided by the manufacturer.



### 3.4.1 CONFIGURATION OF SYSTEM UNDER TEST

#### TEST MODE A

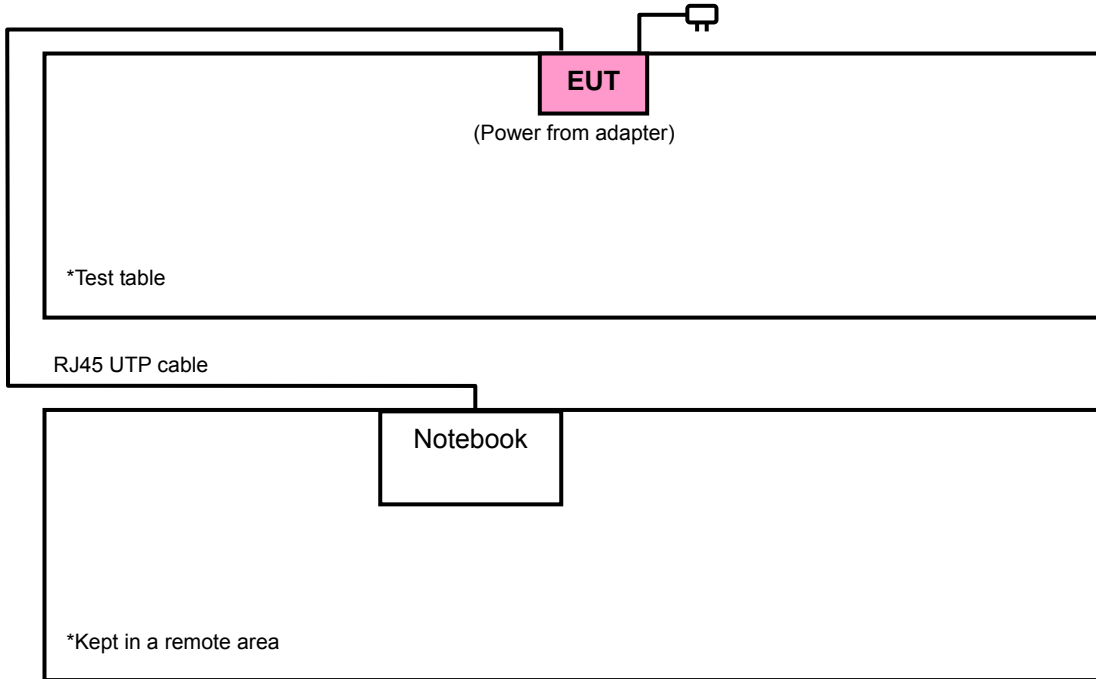

#### TEST MODE B

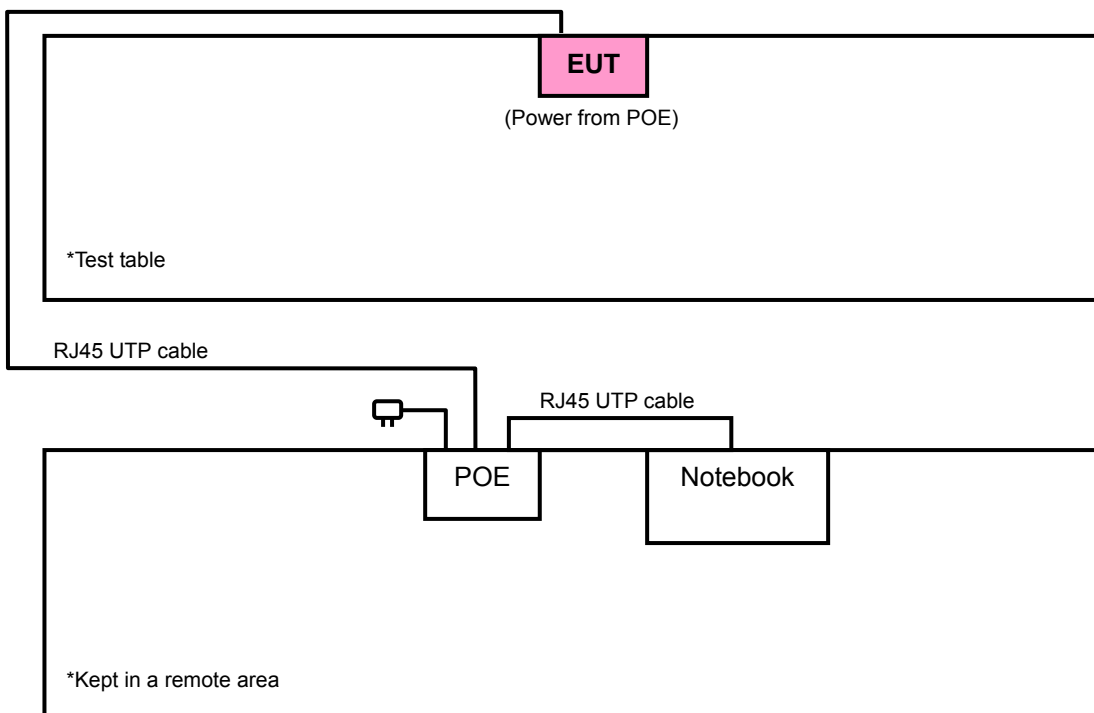

### 3.5 GENERAL DESCRIPTION OF APPLIED STANDARDS

The EUT is a RF Product. According to the specifications of the manufacturer, it must comply with the requirements of the following standards:

**FCC Part 15, Subpart E (15.407)**

**789033 D01 General UNII Test Procedures v01 r03**

**662911 D01 Multiple Transmitter Output v02**

ANSI C63.10-2009

All test items have been performed and recorded as per the above standards.

**NOTE:** The EUT is also considered as a kind of computer peripheral, because the connection to computer is necessary for typical use. It has been verified to comply with the requirements of FCC Part 15, Subpart B, Class B (DoC). The test report has been issued separately.

## 4. TEST TYPES AND RESULTS

### 4.1 RADIATED EMISSION AND BANDEDGE MEASUREMENT

#### 4.1.1 LIMITS OF RADIATED EMISSION AND BANDEDGE MEASUREMENT

Radiated emissions which fall in the restricted bands must comply with the radiated emission limits specified as below table:

FREQUENCIES (MHz)	FIELD STRENGTH (microvolts/meter)	MEASUREMENT DISTANCE (meters)
0.009 ~ 0.490	2400/F(kHz)	300
0.490 ~ 1.705	24000/F(kHz)	30
1.705 ~ 30.0	30	30
30 ~ 88	100	3
88 ~ 216	150	3
216 ~ 960	200	3
Above 960	500	3

**NOTE:**

1. The lower limit shall apply at the transition frequencies.
2. Emission level (dBuV/m) = 20 log Emission level (uV/m).
3. For frequencies above 1000MHz, the field strength limits are based on average detector, however, the peak field strength of any emission shall not exceed the maximum permitted average limits, specified above by more than 20dB under any condition of modulation.

#### 4.1.2 LIMITS OF UNWANTED EMISSION OUT OF THE RESTRICTED BANDS

APPLICABLE TO	LIMIT	
√	FIELD STRENGTH AT 3m (dBμV/m)	
	PK	AV
	74	54
	EIRP LIMIT (dBm)	EQUIVALENT FIELD STRENGTH AT 3m (dBμV/m)
	PK	PK
	-27	68.3

**NOTE:** The following formula is used to convert the equipment isotropic radiated power (eirp) to field strength:

$$E = \frac{1000000\sqrt{30P}}{3} \mu\text{V/m, where P is the eirp (Watts).}$$

#### 4.1.3 TEST INSTRUMENTS

DESCRIPTION & MANUFACTURER	MODEL NO.	SERIAL NO.	DATE OF CALIBRATION	DUE DATE OF CALIBRATION
Test Receiver ROHDE & SCHWARZ	ESIB7	100187	Jan. 03, 2013	Jan. 02, 2014
			Jan. 02, 2014	Jan. 01, 2015
Spectrum Analyzer ROHDE & SCHWARZ	FSP40	100039	Jan. 31, 2013	Jan. 30, 2014
BILOG Antenna SCHWARZBECK	VULB9168	9168-160	Mar. 20, 2013	Mar. 19, 2014
HORN Antenna SCHWARZBECK	9120D	209	Sep. 12, 2013	Sep. 11, 2014
HORN Antenna SCHWARZBECK	BBHA 9170	148	Jul. 15, 2013	Jul. 14, 2014
Preamplifier Agilent	8447D	2944A10633	Oct. 07, 2013	Oct. 06, 2014
Preamplifier Agilent	8449B	3008A01964	Aug. 26, 2013	Aug. 25, 2014
RF signal cable HUBER+SUHNNER	SUCOFLEX 104	214378/4	Aug. 26, 2013	Aug. 25, 2014
RF signal cable HUBER+SUHNNER	SUCOFLEX 106	12738/6+309224/ 4	Aug. 26, 2013	Aug. 25, 2014
Software BV ADT	ADT_Radiated_ V7.6.15.9.4	NA	NA	NA
Antenna Tower inn-co GmbH	MA 4000	013303	NA	NA
Antenna Tower Controller inn-co GmbH	CO2000	017303	NA	NA
Turn Table BV ADT	TT100	TT93021703	NA	NA
Turn Table Controller BV ADT	SC100	SC93021703	NA	NA
26GHz ~ 40GHz Amplifier	EM26400	815221	Oct. 18, 2013	Oct. 17, 2014
Power Sensor	MA2411B	0738404	Apr. 28, 2012	Apr. 27, 2013
WIT Standard Temperature And Humidity Chamber	TH-4S-C	W981030	Jun. 13, 2013	Jun. 12, 2014

- NOTE:**
1. The calibration interval of the above test instruments is 12 months and the calibrations are traceable to NML/ROC and NIST/USA.
  2. The test was performed in HwaYa Chamber 3.
  3. The horn antenna and HP preamplifier (model: 8449B) are used only for the measurement of emission frequency above 1GHz if tested.
  4. The FCC Site Registration No. is 988962.
  5. The IC Site Registration No. is IC 7450F-3.

#### 4.1.4 TEST PROCEDURES

- a. The EUT was placed on the top of a rotating table 0.8 meters above the ground at a 3 meter semi-anechoic chamber. The table was rotated 360 degrees to determine the position of the highest radiation.
- b. The EUT was set 3 meters away from the interference-receiving antenna, which was mounted on the top of a variable-height antenna tower.
- c. The antenna is a broadband antenna, and its height is varied from one meter to four meters above the ground to determine the maximum value of the field strength. Both horizontal and vertical polarizations of the antenna are set to make the measurement.
- d. For each suspected emission, the EUT was arranged to its worst case and then the antenna was tuned to heights from 1 meter to 4 meters and the rotatable table was turned from 0 degrees to 360 degrees to find the maximum reading.
- e. The test-receiver system was set to Peak Detect Function and Specified Bandwidth with Maximum Hold Mode.
- f. If the emission level of the EUT in peak mode was 10dB lower than the limit specified, then testing could be stopped and the peak values of the EUT would be reported. Otherwise the emissions that did not have 10dB margin would be re-tested one by one using peak, quasi-peak or average method as specified and then reported in a data sheet.

**NOTE:**

1. The resolution bandwidth and video bandwidth of test receiver/spectrum analyzer is 120kHz for Quasi-peak detection at frequency below 1GHz.
2. The resolution bandwidth of test receiver/spectrum analyzer is 1MHz and video bandwidth is 3MHz for Peak detection at frequency above 1GHz.
3. The resolution bandwidth of test receiver/spectrum analyzer is 1MHz and the video bandwidth is  $\geq 1/T$  (Duty cycle < 98%) or 10Hz(Duty cycle > 98%) for Average detection (AV) at frequency above 1GHz.
4. All modes of operation were investigated and the worst-case emissions are reported.

#### 4.1.5 DEVIATION FROM TEST STANDARD

No deviation.

#### 4.1.6 TEST SETUP

##### Frequency range 30MHz~1GHz

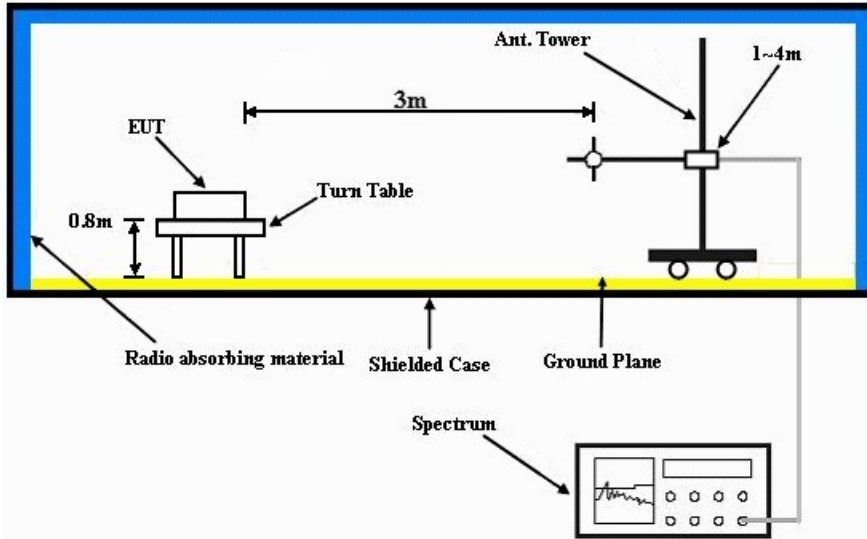

##### Frequency range above 1GHz

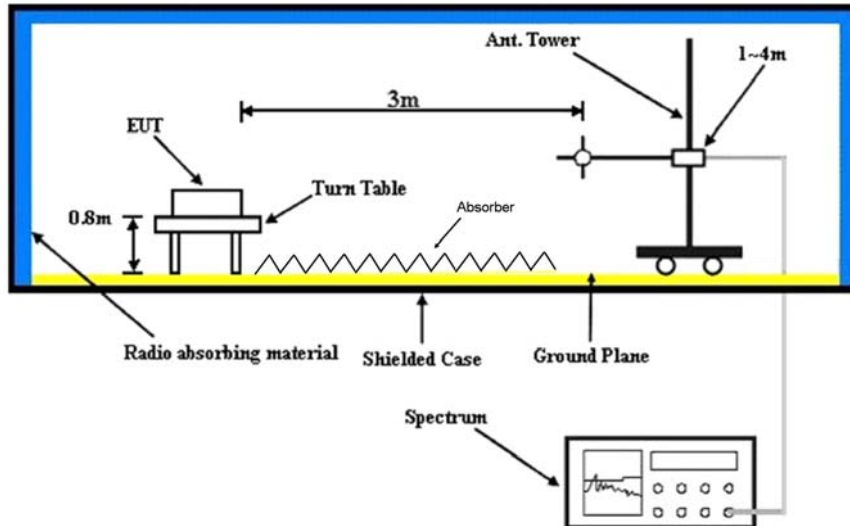

For the actual test configuration, please refer to the attached file (Test Setup Photo).

#### 4.1.7 EUT OPERATING CONDITION

- a. Placed the EUT on the testing table.
- b. Prepared notebook to act as communication partner and placed it outside of testing area.
- c. The communication partner connected with EUT via a RJ45 cable and ran a test program (provided by manufacturer) to enable EUT under transmission condition continuously at specific channel frequency.
- d. The communication partner sent data to EUT by command "PING".

#### 4.1.8 TEST RESULTS

#### ABOVE 1GHz DATA :

#### 802.11a

EUT TEST CONDITION		MEASUREMENT DETAIL	
CHANNEL	Channel 36	FREQUENCY RANGE	1 ~ 40GHz
INPUT POWER	120Vac, 60Hz	DETECTOR FUNCTION	Peak (PK) Average (AV)
ENVIRONMENTAL CONDITIONS	25deg. C, 65%RH	TESTED BY	Ted Chang

ANTENNA POLARITY & TEST DISTANCE: HORIZONTAL AT 3 M								
NO.	FREQ. (MHz)	EMISSION LEVEL (dBuV/m)	LIMIT (dBuV/m)	MARGIN (dB)	ANTENNA HEIGHT (m)	TABLE ANGLE (Degree)	RAW VALUE (dBuV)	CORRECTION FACTOR (dB/m)
1	#5150.00	58.4 PK	74.0	-15.6	1.00 H	121	53.30	5.10
2	#5150.00	46.3 AV	54.0	-7.7	1.00 H	121	41.20	5.10
3	*5180.00	100.1 PK			1.00 H	142	62.40	37.70
4	*5180.00	90.5 AV			1.00 H	142	52.80	37.70
5	#5320.00	59.1 PK	74.0	-14.9	1.00 H	133	53.70	5.40
6	#5320.00	45.6 AV	54.0	-8.4	1.00 H	133	40.20	5.40
7	#10360.00	60.1 PK	74.0	-13.9	1.51 H	100	42.60	17.50
8	#10360.00	46.1 AV	54.0	-7.9	1.51 H	100	28.60	17.50

ANTENNA POLARITY & TEST DISTANCE: VERTICAL AT 3 M								
NO.	FREQ. (MHz)	EMISSION LEVEL (dBuV/m)	LIMIT (dBuV/m)	MARGIN (dB)	ANTENNA HEIGHT (m)	TABLE ANGLE (Degree)	RAW VALUE (dBuV)	CORRECTION FACTOR (dB/m)
1	#5150.00	58.6 PK	74.0	-15.4	1.54 V	188	53.50	5.10
2	#5150.00	45.6 AV	54.0	-8.4	1.54 V	188	40.50	5.10
3	*5180.00	109.2 PK			1.00 V	158	71.50	37.70
4	*5180.00	98.7 AV			1.00 V	158	61.00	37.70
5	#5320.00	60.5 PK	74.0	-13.5	1.00 V	160	55.10	5.40
6	#5320.00	48.5 AV	54.0	-5.5	1.00 V	160	43.10	5.40
7	#10360.00	60.7 PK	74.0	-13.3	1.02 V	188	43.20	17.50
8	#10360.00	48.0 AV	54.0	-6.0	1.02 V	188	30.50	17.50

#### REMARKS:

- Emission Level(dBuV/m) = Raw Value(dBuV) + Correction Factor(dB/m)
- Correction Factor(dB/m) = Antenna Factor(dB/m) + Cable Factor(dB)  
– Pre-Amplifier Factor(dB)
- The other emission levels were very low against the limit.
- Margin value = Emission Level – Limit value
- " \* ": Fundamental frequency.
- "#":The radiated frequency is out the restricted band.





A D T

EUT TEST CONDITION		MEASUREMENT DETAIL	
CHANNEL	Channel 40	FREQUENCY RANGE	1 ~ 40GHz
INPUT POWER	120Vac, 60Hz	DETECTOR FUNCTION	Peak (PK) Average (AV)
ENVIRONMENTAL CONDITIONS	25deg. C, 65%RH	TESTED BY	Ted Chang

ANTENNA POLARITY & TEST DISTANCE: HORIZONTAL AT 3 M								
NO.	FREQ. (MHz)	EMISSION LEVEL (dBuV/m)	LIMIT (dBuV/m)	MARGIN (dB)	ANTENNA HEIGHT (m)	TABLE ANGLE (Degree)	RAW VALUE (dBuV)	CORRECTION FACTOR (dB/m)
1	*5200.00	101.8 PK			1.00 H	288	64.00	37.80
2	*5200.00	92.3 AV			1.00 H	288	54.50	37.80
3	#5360.00	58.9 PK	74.0	-15.1	1.52 H	199	53.50	5.40
4	#5360.00	46.6 AV	54.0	-7.4	1.52 H	199	41.20	5.40
5	#10400.00	61.5 PK	74.0	-12.5	1.02 H	153	43.70	17.80
6	#10400.00	47.9 AV	54.0	-6.1	1.02 H	153	30.10	17.80
ANTENNA POLARITY & TEST DISTANCE: VERTICAL AT 3 M								
NO.	FREQ. (MHz)	EMISSION LEVEL (dBuV/m)	LIMIT (dBuV/m)	MARGIN (dB)	ANTENNA HEIGHT (m)	TABLE ANGLE (Degree)	RAW VALUE (dBuV)	CORRECTION FACTOR (dB/m)
1	*5200.00	108.7 PK			1.00 V	154	70.90	37.80
2	*5200.00	98.9 AV			1.00 V	154	61.10	37.80
3	#5360.00	59.9 PK	74.0	-14.1	1.46 V	126	54.50	5.40
4	#5360.00	49.1 AV	54.0	-4.9	1.46 V	126	43.70	5.40
5	#10400.00	61.8 PK	74.0	-12.2	1.54 V	118	44.00	17.80
6	#10400.00	48.3 AV	54.0	-5.7	1.54 V	118	30.50	17.80

**REMARKS:**

1. Emission Level(dBuV/m) = Raw Value(dBuV) + Correction Factor(dB/m)
2. Correction Factor(dB/m) = Antenna Factor(dB/m) + Cable Factor(dB)  
– Pre-Amplifier Factor(dB)
3. The other emission levels were very low against the limit.
4. Margin value = Emission Level – Limit value
5. “ \* “: Fundamental frequency.
6. “#“:The radiated frequency is out the restricted band.



A D T

EUT TEST CONDITION		MEASUREMENT DETAIL	
CHANNEL	Channel 48	FREQUENCY RANGE	1 ~ 40GHz
INPUT POWER	120Vac, 60Hz	DETECTOR FUNCTION	Peak (PK) Average (AV)
ENVIRONMENTAL CONDITIONS	25deg. C, 65%RH	TESTED BY	Ted Chang

ANTENNA POLARITY & TEST DISTANCE: HORIZONTAL AT 3 M								
NO.	FREQ. (MHz)	EMISSION LEVEL (dBuV/m)	LIMIT (dBuV/m)	MARGIN (dB)	ANTENNA HEIGHT (m)	TABLE ANGLE (Degree)	RAW VALUE (dBuV)	CORRECTION FACTOR (dB/m)
1	*5240.00	101.5 PK			1.00 H	257	63.60	37.90
2	*5240.00	91.3 AV			1.00 H	257	53.40	37.90
3	#53350.00	58.6 PK	74.0	-15.4	1.02 H	112	53.20	5.40
4	#53350.00	45.6 AV	54.0	-8.4	1.02 H	112	40.20	5.40
5	#10480.00	61.0 PK	74.0	-13.0	1.00 H	159	42.70	18.30
6	#10480.00	47.8 AV	54.0	-6.2	1.00 H	159	29.50	18.30
ANTENNA POLARITY & TEST DISTANCE: VERTICAL AT 3 M								
NO.	FREQ. (MHz)	EMISSION LEVEL (dBuV/m)	LIMIT (dBuV/m)	MARGIN (dB)	ANTENNA HEIGHT (m)	TABLE ANGLE (Degree)	RAW VALUE (dBuV)	CORRECTION FACTOR (dB/m)
1	*5240.00	109.3 PK			1.00 V	159	71.40	37.90
2	*5240.00	99.5 AV			1.00 V	159	61.60	37.90
3	#53350.00	61.6 PK	74.0	-12.4	1.02 V	115	56.20	5.40
4	#53350.00	47.9 AV	54.0	-6.1	1.02 V	115	42.50	5.40
5	#10480.00	62.0 PK	74.0	-12.0	1.26 V	336	43.70	18.30
6	#10480.00	48.9 AV	54.0	-5.1	1.26 V	336	30.60	18.30

**REMARKS:**

1. Emission Level(dBuV/m) = Raw Value(dBuV) + Correction Factor(dB/m)
2. Correction Factor(dB/m) = Antenna Factor(dB/m) + Cable Factor(dB)  
– Pre-Amplifier Factor(dB)
3. The other emission levels were very low against the limit.
4. Margin value = Emission Level – Limit value
5. “ \* “: Fundamental frequency.
6. “#”:The radiated frequency is out the restricted band.

802.11n (20MHz)

EUT TEST CONDITION		MEASUREMENT DETAIL	
CHANNEL	Channel 36	FREQUENCY RANGE	1 ~ 40GHz
INPUT POWER	120Vac, 60Hz	DETECTOR FUNCTION	Peak (PK) Average (AV)
ENVIRONMENTAL CONDITIONS	25deg. C, 65%RH	TESTED BY	Ted Chang

ANTENNA POLARITY & TEST DISTANCE: HORIZONTAL AT 3 M								
NO.	FREQ. (MHz)	EMISSION LEVEL (dBuV/m)	LIMIT (dBuV/m)	MARGIN (dB)	ANTENNA HEIGHT (m)	TABLE ANGLE (Degree)	RAW VALUE (dBuV)	CORRECTION FACTOR (dB/m)
1	#5150.00	58.6 PK	74.0	-15.4	1.52 H	117	53.50	5.10
2	#5150.00	46.5 AV	54.0	-7.5	1.52 H	117	41.40	5.10
3	*5180.00	99.9 PK			4.00 H	141	62.20	37.70
4	*5180.00	91.7 AV			4.00 H	141	54.00	37.70
5	#10360.00	60.7 PK	74.0	-13.3	1.59 H	286	43.20	17.50
6	#10360.00	46.2 AV	54.0	-7.8	1.59 H	286	28.70	17.50
ANTENNA POLARITY & TEST DISTANCE: VERTICAL AT 3 M								
NO.	FREQ. (MHz)	EMISSION LEVEL (dBuV/m)	LIMIT (dBuV/m)	MARGIN (dB)	ANTENNA HEIGHT (m)	TABLE ANGLE (Degree)	RAW VALUE (dBuV)	CORRECTION FACTOR (dB/m)
1	#5150.00	58.8 PK	74.0	-15.2	1.52 V	155	53.70	5.10
2	#5150.00	45.6 AV	54.0	-8.4	1.52 V	155	40.50	5.10
3	*5180.00	108.9 PK			1.00 V	159	71.20	37.70
4	*5180.00	99.1 AV			1.00 V	159	61.40	37.70
5	#10360.00	61.2 PK	74.0	-12.8	1.48 V	188	43.70	17.50
6	#10360.00	48.1 AV	54.0	-5.9	1.48 V	188	30.60	17.50

**REMARKS:**

1. Emission Level(dBuV/m) = Raw Value(dBuV) + Correction Factor(dB/m)
2. Correction Factor(dB/m) = Antenna Factor(dB/m) + Cable Factor(dB)  
– Pre-Amplifier Factor(dB)
3. The other emission levels were very low against the limit.
4. Margin value = Emission Level – Limit value
5. “ \* “: Fundamental frequency.
6. “#”:The radiated frequency is out the restricted band.



A D T

EUT TEST CONDITION		MEASUREMENT DETAIL	
CHANNEL	Channel 40	FREQUENCY RANGE	1 ~ 40GHz
INPUT POWER	120Vac, 60Hz	DETECTOR FUNCTION	Peak (PK) Average (AV)
ENVIRONMENTAL CONDITIONS	25deg. C, 65%RH	TESTED BY	Ted Chang

ANTENNA POLARITY & TEST DISTANCE: HORIZONTAL AT 3 M								
NO.	FREQ. (MHz)	EMISSION LEVEL (dBuV/m)	LIMIT (dBuV/m)	MARGIN (dB)	ANTENNA HEIGHT (m)	TABLE ANGLE (Degree)	RAW VALUE (dBuV)	CORRECTION FACTOR (dB/m)
1	*5200.00	101.6 PK			1.00 H	289	63.80	37.80
2	*5200.00	92.7 AV			1.00 H	289	54.90	37.80
3	#10400.00	60.4 PK	74.0	-13.6	1.36 H	226	42.60	17.80
4	#10400.00	48.0 AV	54.0	-6.0	1.36 H	226	30.20	17.80
ANTENNA POLARITY & TEST DISTANCE: VERTICAL AT 3 M								
NO.	FREQ. (MHz)	EMISSION LEVEL (dBuV/m)	LIMIT (dBuV/m)	MARGIN (dB)	ANTENNA HEIGHT (m)	TABLE ANGLE (Degree)	RAW VALUE (dBuV)	CORRECTION FACTOR (dB/m)
1	*5200.00	108.3 PK			1.00 V	156	70.50	37.80
2	*5200.00	99.1 AV			1.00 V	156	61.30	37.80
3	#10400.00	61.3 PK	74.0	-12.7	1.22 V	152	43.50	17.80
4	#10400.00	48.5 AV	54.0	-5.5	1.22 V	152	30.70	17.80

**REMARKS:**

1. Emission Level(dBuV/m) = Raw Value(dBuV) + Correction Factor(dB/m)
2. Correction Factor(dB/m) = Antenna Factor(dB/m) + Cable Factor(dB) – Pre-Amplifier Factor(dB)
3. The other emission levels were very low against the limit.
4. Margin value = Emission Level – Limit value
5. “ \* “: Fundamental frequency.
6. “#“:The radiated frequency is out the restricted band.



A D T

EUT TEST CONDITION		MEASUREMENT DETAIL	
CHANNEL	Channel 48	FREQUENCY RANGE	1 ~ 40GHz
INPUT POWER	120Vac, 60Hz	DETECTOR FUNCTION	Peak (PK) Average (AV)
ENVIRONMENTAL CONDITIONS	25deg. C, 65%RH	TESTED BY	Ted Chang

ANTENNA POLARITY & TEST DISTANCE: HORIZONTAL AT 3 M								
NO.	FREQ. (MHz)	EMISSION LEVEL (dBuV/m)	LIMIT (dBuV/m)	MARGIN (dB)	ANTENNA HEIGHT (m)	TABLE ANGLE (Degree)	RAW VALUE (dBuV)	CORRECTION FACTOR (dB/m)
1	*5240.00	101.4 PK			1.00 H	258	63.50	37.90
2	*5240.00	91.6 AV			1.00 H	258	53.70	37.90
3	#53350.00	59.3 PK	74.0	-14.7	1.54 H	220	53.90	5.40
4	#53350.00	46.6 AV	54.0	-7.4	1.54 H	220	41.20	5.40
5	#10480.00	62.0 PK	74.0	-12.0	1.00 H	192	43.70	18.30
6	#10480.00	48.9 AV	54.0	-5.1	1.00 H	192	30.60	18.30
ANTENNA POLARITY & TEST DISTANCE: VERTICAL AT 3 M								
NO.	FREQ. (MHz)	EMISSION LEVEL (dBuV/m)	LIMIT (dBuV/m)	MARGIN (dB)	ANTENNA HEIGHT (m)	TABLE ANGLE (Degree)	RAW VALUE (dBuV)	CORRECTION FACTOR (dB/m)
1	*5240.00	109.5 PK			1.00 V	161	71.60	37.90
2	*5240.00	99.7 AV			1.00 V	161	61.80	37.90
3	#53350.00	60.0 PK	74.0	-14.0	1.00 V	116	54.60	5.40
4	#53350.00	47.1 AV	54.0	-6.9	1.00 V	116	41.70	5.40
5	#10480.00	62.3 PK	74.0	-11.7	1.02 V	336	44.00	18.30
6	#10480.00	48.5 AV	54.0	-5.5	1.02 V	336	30.20	18.30

**REMARKS:**

1. Emission Level(dBuV/m) = Raw Value(dBuV) + Correction Factor(dB/m)
2. Correction Factor(dB/m) = Antenna Factor(dB/m) + Cable Factor(dB)  
– Pre-Amplifier Factor(dB)
3. The other emission levels were very low against the limit.
4. Margin value = Emission Level – Limit value
5. “ \* “: Fundamental frequency.
6. “#”:The radiated frequency is out the restricted band.

802.11n (40MHz)

EUT TEST CONDITION		MEASUREMENT DETAIL	
CHANNEL	Channel 38	FREQUENCY RANGE	1 ~ 40GHz
INPUT POWER	120Vac, 60Hz	DETECTOR FUNCTION	Peak (PK) Average (AV)
ENVIRONMENTAL CONDITIONS	25deg. C, 65%RH	TESTED BY	Ted Chang

ANTENNA POLARITY & TEST DISTANCE: HORIZONTAL AT 3 M								
NO.	FREQ. (MHz)	EMISSION LEVEL (dBuV/m)	LIMIT (dBuV/m)	MARGIN (dB)	ANTENNA HEIGHT (m)	TABLE ANGLE (Degree)	RAW VALUE (dBuV)	CORRECTION FACTOR (dB/m)
1	#5150.00	58.7 PK	74.0	-15.3	1.59 H	324	53.60	5.10
2	#5150.00	45.6 AV	54.0	-8.4	1.59 H	324	40.50	5.10
3	*5190.00	97.6 PK			1.12 H	288	59.80	37.80
4	*5190.00	87.8 AV			1.12 H	288	50.00	37.80
5	#10380.00	61.2 PK	74.0	-12.8	1.96 H	289	43.60	17.60
6	#10380.00	46.5 AV	54.0	-7.5	1.96 H	289	28.90	17.60
ANTENNA POLARITY & TEST DISTANCE: VERTICAL AT 3 M								
NO.	FREQ. (MHz)	EMISSION LEVEL (dBuV/m)	LIMIT (dBuV/m)	MARGIN (dB)	ANTENNA HEIGHT (m)	TABLE ANGLE (Degree)	RAW VALUE (dBuV)	CORRECTION FACTOR (dB/m)
1	#5150.00	62.0 PK	74.0	-12.0	1.27 V	129	56.90	5.10
2	#5150.00	48.2 AV	54.0	-5.8	1.27 V	129	43.10	5.10
3	*5190.00	105.8 PK			1.01 V	159	68.00	37.80
4	*5190.00	95.8 AV			1.01 V	159	58.00	37.80
5	#10380.00	61.4 PK	74.0	-12.6	1.05 V	188	43.80	17.60
6	#10380.00	48.1 AV	54.0	-5.9	1.05 V	188	30.50	17.60

**REMARKS:**

1. Emission Level(dBuV/m) = Raw Value(dBuV) + Correction Factor(dB/m)
2. Correction Factor(dB/m) = Antenna Factor(dB/m) + Cable Factor(dB)  
– Pre-Amplifier Factor(dB)
3. The other emission levels were very low against the limit.
4. Margin value = Emission Level – Limit value
5. “ \* “: Fundamental frequency.
6. “#”:The radiated frequency is out the restricted band.

EUT TEST CONDITION		MEASUREMENT DETAIL	
CHANNEL	Channel 46	FREQUENCY RANGE	1 ~ 40GHz
INPUT POWER	120Vac, 60Hz	DETECTOR FUNCTION	Peak (PK) Average (AV)
ENVIRONMENTAL CONDITIONS	25deg. C, 65%RH	TESTED BY	Ted Chang

ANTENNA POLARITY & TEST DISTANCE: HORIZONTAL AT 3 M								
NO.	FREQ. (MHz)	EMISSION LEVEL (dBuV/m)	LIMIT (dBuV/m)	MARGIN (dB)	ANTENNA HEIGHT (m)	TABLE ANGLE (Degree)	RAW VALUE (dBuV)	CORRECTION FACTOR (dB/m)
1	*5230.00	98.5 PK			1.47 H	287	60.60	37.90
2	*5230.00	88.6 AV			1.47 H	287	50.70	37.90
3	#5350.00	56.9 PK	74.0	-17.1	1.02 H	152	51.50	5.40
4	#5350.00	45.6 AV	54.0	-8.4	1.02 H	152	40.20	5.40
5	#10460.00	61.1 PK	74.0	-12.9	1.05 H	172	43.00	18.10
6	#10460.00	46.7 AV	54.0	-7.3	1.05 H	172	28.60	18.10
ANTENNA POLARITY & TEST DISTANCE: VERTICAL AT 3 M								
NO.	FREQ. (MHz)	EMISSION LEVEL (dBuV/m)	LIMIT (dBuV/m)	MARGIN (dB)	ANTENNA HEIGHT (m)	TABLE ANGLE (Degree)	RAW VALUE (dBuV)	CORRECTION FACTOR (dB/m)
1	*5230.00	105.7 PK			1.12 V	155	67.80	37.90
2	*5230.00	95.8 AV			1.12 V	155	57.90	37.90
3	#5350.00	59.2 PK	74.0	-14.8	1.02 V	114	53.80	5.40
4	#5350.00	46.6 AV	54.0	-7.4	1.02 V	114	41.20	5.40
5	#10460.00	61.7 PK	74.0	-12.3	1.05 V	154	43.60	18.10
6	#10460.00	48.6 AV	54.0	-5.4	1.05 V	154	30.50	18.10

**REMARKS:**

1. Emission Level(dBuV/m) = Raw Value(dBuV) + Correction Factor(dB/m)
2. Correction Factor(dB/m) = Antenna Factor(dB/m) + Cable Factor(dB)  
– Pre-Amplifier Factor(dB)
3. The other emission levels were very low against the limit.
4. Margin value = Emission Level – Limit value
5. " \* ": Fundamental frequency.
6. "#":The radiated frequency is out the restricted band.

**BELOW 1GHz WORST-CASE DATA : 802.11a**

EUT TEST CONDITION		MEASUREMENT DETAIL	
CHANNEL	Channel 36	FREQUENCY RANGE	Below 1000MHz
INPUT POWER	120Vac, 60Hz	DETECTOR FUNCTION	Quasi-Peak
ENVIRONMENTAL CONDITIONS	25deg. C, 65%RH	TESTED BY	Ted Chang
TEST MODE	A		

ANTENNA POLARITY & TEST DISTANCE: HORIZONTAL AT 3 M								
NO.	FREQ. (MHz)	EMISSION LEVEL (dBuV/m)	LIMIT (dBuV/m)	MARGIN (dB)	ANTENNA HEIGHT (m)	TABLE ANGLE (Degree)	RAW VALUE (dBuV)	CORRECTION FACTOR (dB/m)
1	80.35	27.8 QP	40.0	-12.2	1.50 H	14	46.10	-18.30
2	142.44	31.6 QP	43.5	-11.9	1.00 H	142	45.90	-14.30
3	190.95	37.5 QP	43.5	-6.0	1.99 H	268	53.90	-16.40
4	268.57	37.4 QP	46.0	-8.6	1.24 H	103	50.80	-13.40
5	390.81	43.2 QP	46.0	-2.8	1.00 H	125	53.80	-10.60
6	728.44	43.5 QP	46.0	-2.5	1.99 H	118	47.30	-3.80

ANTENNA POLARITY & TEST DISTANCE: VERTICAL AT 3 M								
NO.	FREQ. (MHz)	EMISSION LEVEL (dBuV/m)	LIMIT (dBuV/m)	MARGIN (dB)	ANTENNA HEIGHT (m)	TABLE ANGLE (Degree)	RAW VALUE (dBuV)	CORRECTION FACTOR (dB/m)
1	76.47	36.2 QP	40.0	-3.8	1.24 V	94	54.10	-17.90
2	187.07	37.9 QP	43.5	-5.6	1.50 V	106	53.90	-16.00
3	303.50	32.7 QP	46.0	-13.3	1.50 V	12	45.00	-12.30
4	400.52	36.3 QP	46.0	-9.7	1.00 V	75	46.80	-10.50
5	513.06	33.0 QP	46.0	-13.0	1.99 V	98	41.20	-8.20
6	722.62	41.5 QP	46.0	-4.5	1.00 V	15	45.40	-3.90

**REMARKS:**

1. Emission Level(dBuV/m) = Raw Value(dBuV) + Correction Factor(dB/m)
2. Correction Factor(dB/m) = Antenna Factor(dB/m) + Cable Factor(dB) – Pre-Amplifier Factor (dB)
3. The other emission levels were very low against the limit.
4. Margin value = Emission Level – Limit value





A D T

EUT TEST CONDITION		MEASUREMENT DETAIL	
CHANNEL	Channel 36	FREQUENCY RANGE	Below 1000MHz
INPUT POWER	48Vdc	DETECTOR FUNCTION	Quasi-Peak
ENVIRONMENTAL CONDITIONS	25deg. C, 65%RH	TESTED BY	Ted Chang
TEST MODE	B		

ANTENNA POLARITY & TEST DISTANCE: HORIZONTAL AT 3 M								
NO.	FREQ. (MHz)	EMISSION LEVEL (dBuV/m)	LIMIT (dBuV/m)	MARGIN (dB)	ANTENNA HEIGHT (m)	TABLE ANGLE (Degree)	RAW VALUE (dBuV)	CORRECTION FACTOR (dB/m)
1	78.41	31.1 QP	40.0	-8.9	1.99 H	54	49.20	-18.10
2	173.49	30.6 QP	43.5	-12.9	1.00 H	55	45.20	-14.60
3	272.45	31.4 QP	46.0	-14.6	1.24 H	106	44.40	-13.00
4	348.13	25.2 QP	46.0	-20.8	1.24 H	100	36.70	-11.50
5	625.60	33.5 QP	46.0	-12.5	1.50 H	125	39.00	-5.50
6	751.73	37.8 QP	46.0	-8.2	1.00 H	125	40.80	-3.00
ANTENNA POLARITY & TEST DISTANCE: VERTICAL AT 3 M								
NO.	FREQ. (MHz)	EMISSION LEVEL (dBuV/m)	LIMIT (dBuV/m)	MARGIN (dB)	ANTENNA HEIGHT (m)	TABLE ANGLE (Degree)	RAW VALUE (dBuV)	CORRECTION FACTOR (dB/m)
1	84.23	32.6 QP	40.0	-7.4	1.00 V	97	52.30	-19.70
2	167.67	32.4 QP	43.5	-11.1	1.50 V	76	46.70	-14.30
3	270.51	30.9 QP	46.0	-15.1	1.50 V	234	44.00	-13.10
4	499.48	25.4 QP	46.0	-20.6	1.00 V	105	33.70	-8.30
5	625.60	32.6 QP	46.0	-13.4	1.99 V	109	38.10	-5.50
6	751.73	28.8 QP	46.0	-17.2	1.00 V	290	31.80	-3.00

**REMARKS:**

1. Emission Level(dBuV/m) = Raw Value(dBuV) + Correction Factor(dB/m)
2. Correction Factor(dB/m) = Antenna Factor(dB/m) + Cable Factor(dB) – Pre-Amplifier Factor (dB)
3. The other emission levels were very low against the limit.
4. Margin value = Emission Level – Limit value

## 4.2 CONDUCTED EMISSION MEASUREMENT

### 4.2.1 LIMITS OF CONDUCTED EMISSION MEASUREMENT

FREQUENCY OF EMISSION (MHz)	CONDUCTED LIMIT (dB $\mu$ V)	
	Quasi-peak	Average
0.15 ~ 0.5	66 to 56	56 to 46
0.5 ~ 5	56	46
5 ~ 30	60	50

- NOTE:**
1. The lower limit shall apply at the transition frequencies.
  2. The limit decreases in line with the logarithm of the frequency in the range of 0.15 to 0.50MHz.
  3. All emanations from a class A/B digital device or system, including any network of conductors and apparatus connected thereto, shall not exceed the level of field strengths specified above.

### 4.2.2 TEST INSTRUMENTS

DESCRIPTION & MANUFACTURER	MODEL NO.	SERIAL NO.	DATE OF CALIBRATION	DUE DATE OF CALIBRATION
Test Receiver ROHDE & SCHWARZ	ESCS30	100289	Nov. 30, 2012	Nov. 29, 2013
			Nov. 29, 2013	Nov. 28, 2014
RF signal cable Woken	5D-FB	Cable-HYC01-01	Dec. 28, 2012	Dec. 27, 2013
			Dec. 27, 2013	Dec. 26, 2014
LISN ROHDE & SCHWARZ (Peripheral)	ESH3-Z5	100311	Jul. 17, 2013	Jul. 16, 2014
LISN ROHDE & SCHWARZ (EUT)	ESH3-Z5	835239/001	Feb. 04, 2013	Feb. 03, 2014
Software ADT	BV ADT_Cond_ V7.3.7.3	NA	NA	NA

- NOTE:**
1. The calibration interval of the above test instruments is 12 months and the calibrations are traceable to NML/ROC and NIST/USA.
  2. The test was performed in HwaYa Shielded Room 1.
  3. The VCCI Site Registration No. is C-2040.

### 4.2.3 TEST PROCEDURES

- a. The EUT was placed 0.4 meters from the conducting wall of the shielded room with EUT being connected to the power mains through a line impedance stabilization network (LISN). Other support units were connected to the power mains through another LISN. The two LISNs provide 50 ohm/ 50uH of coupling impedance for the measuring instrument.
- b. Both lines of the power mains connected to the EUT were checked for maximum conducted interference.
- c. The frequency range from 150kHz to 30MHz was searched. Emission levels under (Limit - 20dB) was not recorded.

**NOTE:** All modes of operation were investigated and the worst-case emissions are reported.

### 4.2.4 DEVIATION FROM TEST STANDARD

No deviation.

### 4.2.5 TEST SETUP

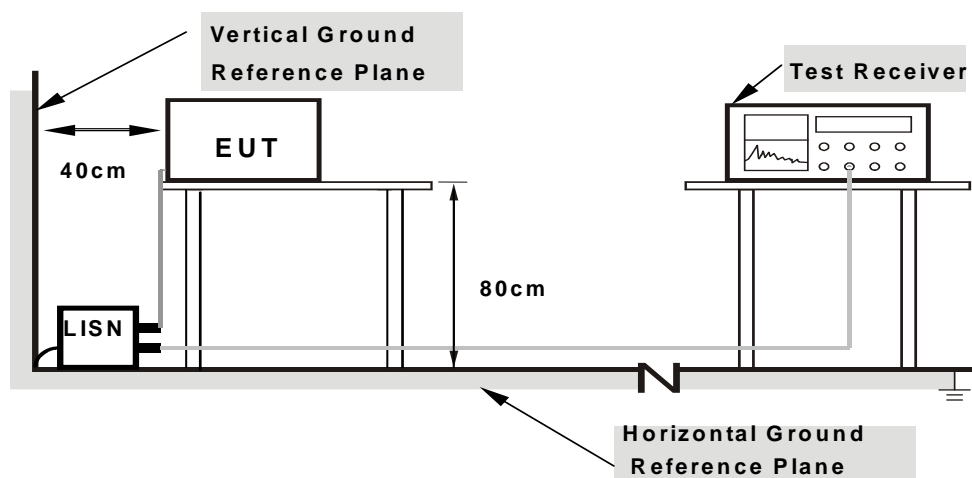

- Note:**
1. Support units were connected to second LISN.
  2. Both of LISNs (AMN) are 80 cm from EUT and at least 80 cm from other units and other metal planes

For the actual test configuration, please refer to the attached file (Test Setup Photo).

### 4.2.6 EUT OPERATING CONDITIONS

Same as 4.1.6.

## 4.2.7 TEST RESULTS

### CONDUCTED WORST-CASE DATA : 802.11a

PHASE	Line 1	6dB BANDWIDTH	9kHz
TEST MODE	A		

No	Freq. [MHz]	Corr. Factor (dB)	Reading Value		Emission Level		Limit		Margin	
			[dB (uV)]		[dB (uV)]		[dB (uV)]		(dB)	
			Q.P.	AV.	Q.P.	AV.	Q.P.	AV.	Q.P.	AV.
1	0.15782	0.10	50.50	34.08	50.60	34.18	65.58	55.58	-14.98	-21.40
2	0.21256	0.10	45.37	31.08	45.47	31.18	63.10	53.10	-17.63	-21.92
3	0.23993	0.10	42.94	30.08	43.04	30.18	62.10	52.10	-19.05	-21.91
4	0.51312	0.12	41.22	33.01	41.34	33.13	56.00	46.00	-14.66	-12.87
5	2.20666	0.18	25.12	16.49	25.30	16.67	56.00	46.00	-30.70	-29.33
6	5.70220	0.30	25.48	17.68	25.78	17.98	60.00	50.00	-34.22	-32.02

### REMARKS:

1. Q.P. and AV. are abbreviations of quasi-peak and average individually.
2. The emission levels of other frequencies were very low against the limit.
3. Margin value = Emission level - Limit value
4. Correction factor = Insertion loss + Cable loss
5. Emission Level = Correction Factor + Reading Value

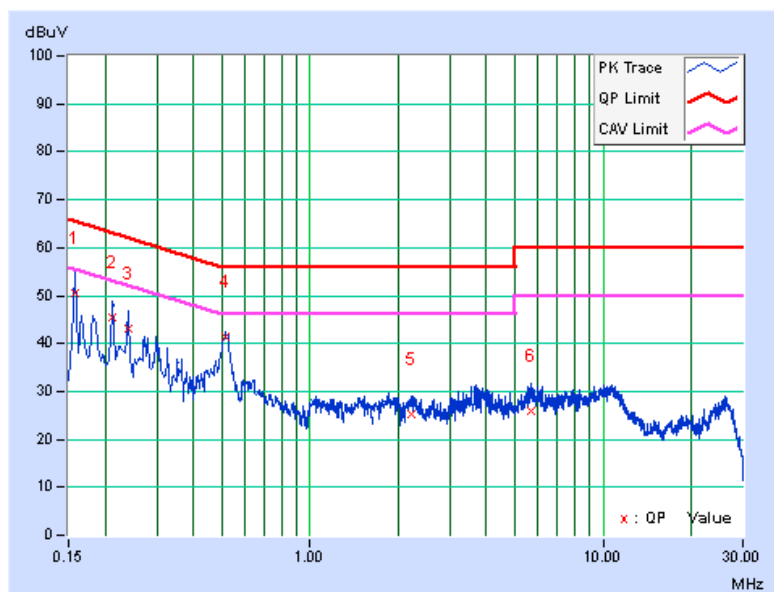



A D T

PHASE	Line 2	6dB BANDWIDTH	9kHz
TEST MODE	A		

No	Freq. [MHz]	Corr. Factor (dB)	Reading Value		Emission Level		Limit		Margin	
			[dB (uV)]		[dB (uV)]		[dB (uV)]		(dB)	
			Q.P.	AV.	Q.P.	AV.	Q.P.	AV.	Q.P.	AV.
1	0.15782	0.11	49.82	32.37	49.93	32.48	65.58	55.58	-15.65	-23.10
2	0.17737	0.11	46.70	29.53	46.81	29.64	64.61	54.61	-17.80	-24.97
3	0.23216	0.11	41.33	27.52	41.44	27.63	62.37	52.37	-20.93	-24.74
4	0.51363	0.13	39.94	31.59	40.07	31.72	56.00	46.00	-15.93	-14.28
5	1.10013	0.14	30.50	21.20	30.64	21.34	56.00	46.00	-25.36	-24.66
6	10.94160	0.39	28.93	21.93	29.32	22.32	60.00	50.00	-30.68	-27.68

**REMARKS:**

1. Q.P. and AV. are abbreviations of quasi-peak and average individually.
2. The emission levels of other frequencies were very low against the limit.
3. Margin value = Emission level - Limit value
4. Correction factor = Insertion loss + Cable loss
5. Emission Level = Correction Factor + Reading Value

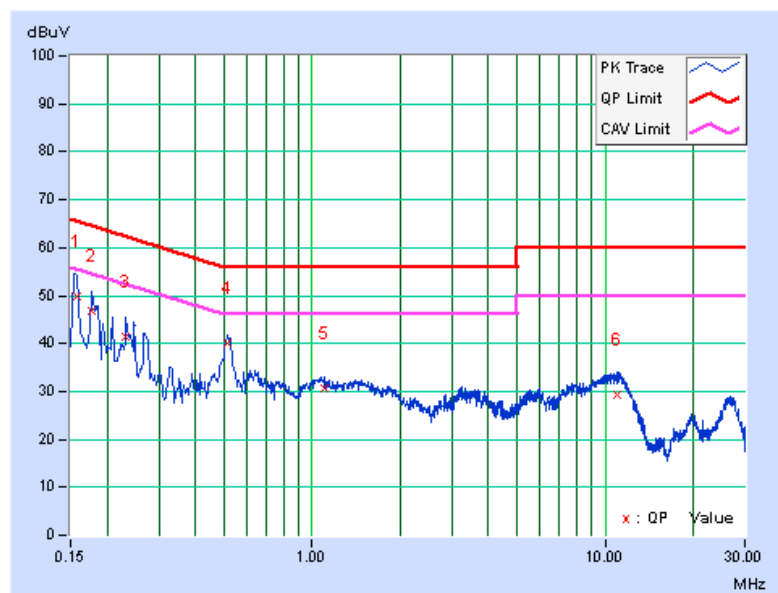



A D T

PHASE	Line 1	6dB BANDWIDTH	9kHz
TEST MODE	B		

No	Freq. [MHz]	Corr. Factor (dB)	Reading Value		Emission Level		Limit		Margin	
			[dB (uV)]		[dB (uV)]		[dB (uV)]		(dB)	
			Q.P.	AV.	Q.P.	AV.	Q.P.	AV.	Q.P.	AV.
1	0.23216	0.10	44.82	40.56	44.92	40.66	62.37	52.37	-17.45	-11.71
2	0.34926	0.11	42.21	39.60	42.32	39.71	58.98	48.98	-16.66	-9.27
<b>3</b>	<b>0.46669</b>	<b>0.12</b>	<b>41.66</b>	<b>38.73</b>	<b>41.78</b>	<b>38.85</b>	<b>56.57</b>	<b>46.57</b>	<b>-14.79</b>	<b>-7.72</b>
4	0.70580	0.13	39.90	34.78	40.03	34.91	56.00	46.00	-15.97	-11.09
5	1.87822	0.17	36.54	28.69	36.71	28.86	56.00	46.00	-19.29	-17.14
6	14.29638	0.67	39.62	37.96	40.29	38.63	60.00	50.00	-19.71	-11.37

**REMARKS:**

1. Q.P. and AV. are abbreviations of quasi-peak and average individually.
2. The emission levels of other frequencies were very low against the limit.
3. Margin value = Emission level - Limit value
4. Correction factor = Insertion loss + Cable loss
5. Emission Level = Correction Factor + Reading Value

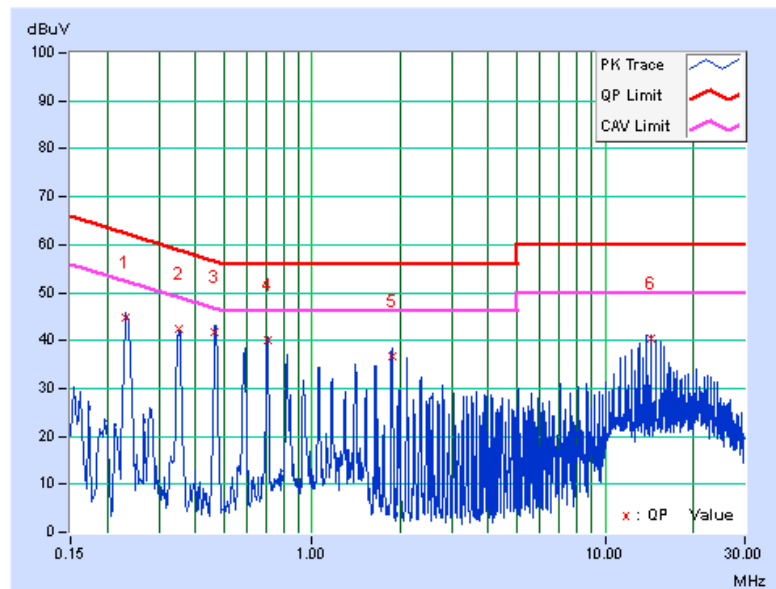



A D T

PHASE	Line 2	6dB BANDWIDTH	9kHz
TEST MODE	B		

No	Freq. [MHz]	Corr. Factor (dB)	Reading Value		Emission Level		Limit		Margin	
			[dB (uV)]		[dB (uV)]		[dB (uV)]		(dB)	
			Q.P.	AV.	Q.P.	AV.	Q.P.	AV.	Q.P.	AV.
1	0.22851	0.11	38.00	30.65	38.11	30.76	62.50	52.50	-24.39	-21.74
2	0.46669	0.13	40.96	38.38	41.09	38.51	56.57	46.57	-15.48	-8.06
3	0.70131	0.14	40.05	36.70	40.19	36.84	56.00	46.00	-15.81	-9.16
4	1.05712	0.14	38.14	33.14	38.28	33.28	56.00	46.00	-17.72	-12.72
5	1.85476	0.16	19.09	0.31	19.25	0.47	56.00	46.00	-36.75	-45.53
6	14.30029	0.47	41.16	39.63	41.63	40.10	60.00	50.00	-18.37	-9.90

**REMARKS:**

1. Q.P. and AV. are abbreviations of quasi-peak and average individually.
2. The emission levels of other frequencies were very low against the limit.
3. Margin value = Emission level - Limit value
4. Correction factor = Insertion loss + Cable loss
5. Emission Level = Correction Factor + Reading Value

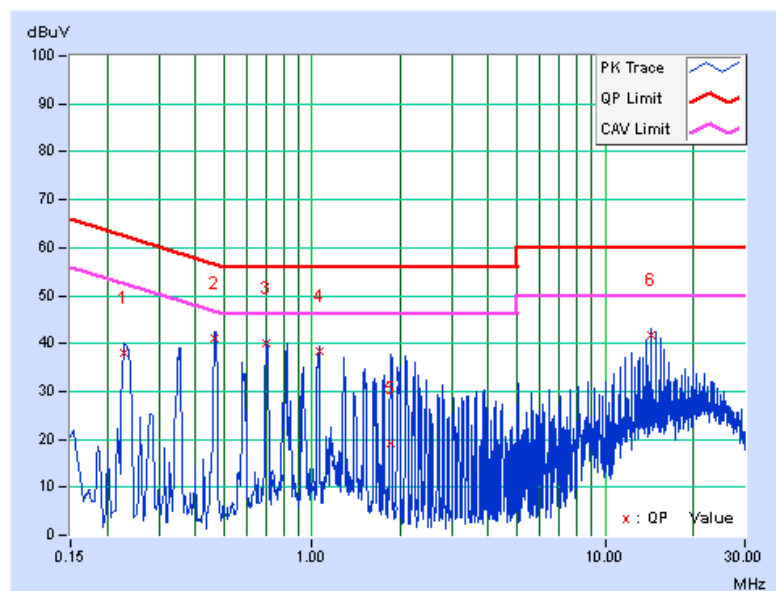

### 4.3 PEAK TRANSMIT POWER MEASUREMENT

#### 4.3.1 LIMITS OF PEAK TRANSMIT POWER MEASUREMENT

FREQUENCY BAND	LIMIT
5.15 ~ 5.25GHz	The lesser of 50mW (17dBm) or 4dBm + 10logB

**NOTE:** Where B is the 26dB emission bandwidth in MHz.

Per KDB 662911 D01 Multiple Transmitter Output v02 Method of conducted output power measurement on IEEE 802.11 devices,

Array Gain = 0 dB (i.e., no array gain) for NANT ≤ 4;

Array Gain = 0 dB (i.e., no array gain) for channel widths ≥ 40 MHz for any NANT;

Array Gain = 5 log(NANT/NSS) dB or 3 dB, whichever is less for 20-MHz channel widths with NANT ≥ 5.

For power measurements on all other devices: Array Gain = 10 log(NANT/NSS) dB.

#### 4.3.2 TEST SETUP

##### FOR POWER OUTPUT MEASUREMENT

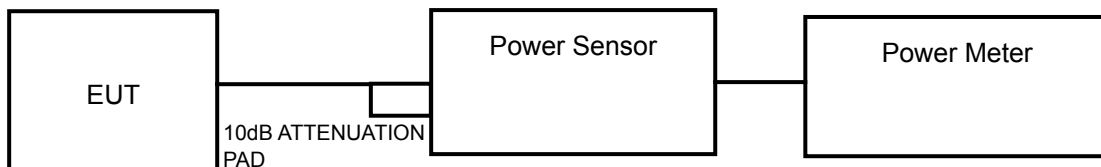

##### FOR 26dB BANDWIDTH

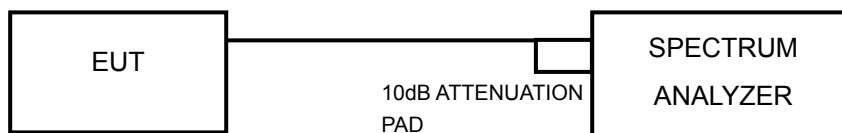

#### 4.3.3 TEST INSTRUMENTS

Refer to section 4.1.3 to get information of above instrument.



#### 4.3.4 TEST PROCEDURE

##### FOR AVERAGE POWER MEASUREMENT

Method PM is used to perform output power measurement, trigger and gating function of wide band power meter is enabled to measure max output power of TX on burst. Duty factor is not added to measured value.

##### FOR 26dB BANDWIDTH

- 1) Set RBW = approximately 1% of the emission bandwidth.
- 2) Set the VBW > RBW.
- 3) Detector = Peak.
- 4) Trace mode = max hold.
- 5) Measure the maximum width of the emission that is 26 dB down from the peak of the emission. Compare this with the RBW setting of the analyzer. Readjust RBW and repeat measurement as needed until the RBW/EBW ratio is approximately 1%.

#### 4.3.5 DEVIATION FROM TEST STANDARD

No deviation.

#### 4.3.6 EUT OPERATING CONDITIONS

The software provided by client to enable the EUT under transmission condition continuously at specific channel frequencies individually.

### 4.3.7 TEST RESULTS

#### POWER OUTPUT:

##### 802.11a

CHAN.	FREQ. (MHz)	AVERAGE POWER (dBm)			TOTAL POWER (mW)	TOTAL POWER (dBm)	POWER LIMIT (dBm)	PASS / FAIL
		CHAIN 0	CHAIN 1	CHAIN 2				
36	5180	8.89	8.65	9.52	24.027	13.81	16.95	PASS
40	5200	8.25	7.87	9.16	21.048	13.23	16.84	PASS
48	5240	8.47	7.01	8.77	19.588	12.92	16.77	PASS

#### NOTE:

##### CHAIN 0

1. 4dBm + 10log ( 20.30 ) = 17.07 > 17dBm
2. 4dBm + 10log ( 19.47 ) = 16.89 < 17dBm
3. 4dBm + 10log ( 20.51 ) = 17.12 > 17dBm

##### CHAIN 1

1. 4dBm + 10log ( 19.74 ) = 16.95 < 17dBm
2. 4dBm + 10log ( 19.21 ) = 16.84 < 17dBm
3. 4dBm + 10log ( 18.92 ) = 16.77 < 17dBm

##### CHAIN 2

1. 4dBm + 10log ( 19.96 ) = 17.00 = 17dBm
2. 4dBm + 10log ( 19.48 ) = 16.90 < 17dBm
3. 4dBm + 10log ( 19.86 ) = 16.98 < 17dBm

##### 802.11n (20MHz)

CHAN.	FREQ. (MHz)	AVERAGE POWER (dBm)			TOTAL POWER (mW)	TOTAL POWER (dBm)	POWER LIMIT (dBm)	PASS / FAIL
		CHAIN 0	CHAIN 1	CHAIN 2				
36	5180	11.47	11.67	12.97	48.532	16.86	17	PASS
40	5200	12.03	11.68	12.65	49.090	16.91	17	PASS
48	5240	12.30	11.50	12.63	<b>49.430</b>	16.94	17	PASS

#### NOTE:

##### CHAIN 0

1. 4dBm + 10log ( 20.52 ) = 17.12 > 17dBm
2. 4dBm + 10log ( 20.70 ) = 17.16 > 17dBm
3. 4dBm + 10log ( 20.83 ) = 17.19 > 17dBm

##### CHAIN 1

1. 4dBm + 10log ( 21.01 ) = 17.22 > 17dBm
2. 4dBm + 10log ( 20.89 ) = 17.20 > 17dBm
3. 4dBm + 10log ( 20.84 ) = 17.19 > 17dBm

##### CHAIN 2

1. 4dBm + 10log ( 20.04 ) = 17.02 > 17dBm
2. 4dBm + 10log ( 20.11 ) = 17.03 > 17dBm
3. 4dBm + 10log ( 20.42 ) = 17.10 > 17dBm



A D T

### 802.11n (40MHz)

CHAN.	FREQ. (MHz)	AVERAGE POWER (dBm)			TOTAL POWER (mW)	TOTAL POWER (dBm)	POWER LIMIT (dBm)	PASS / FAIL
		CHAIN 0	CHAIN 1	CHAIN 2				
38	5190	11.75	11.50	12.38	46.385	16.66	17	PASS
46	5230	12.25	11.33	12.61	48.610	16.87	17	PASS

**NOTE:**

**CHAIN 0**

1.  $4\text{dBm} + 10\log ( 49.15 ) = 20.92 > 17\text{dBm}$
2.  $4\text{dBm} + 10\log ( 47.55 ) = 20.77 > 17\text{dBm}$

**CHAIN 1**

1.  $4\text{dBm} + 10\log ( 45.05 ) = 20.54 > 17\text{dBm}$
2.  $4\text{dBm} + 10\log ( 45.22 ) = 20.55 > 17\text{dBm}$

**CHAIN 2**

1.  $4\text{dBm} + 10\log ( 46.78 ) = 20.70 > 17\text{dBm}$
2.  $4\text{dBm} + 10\log ( 45.54 ) = 20.58 > 17\text{dBm}$



**26dB BANDWIDTH:**

**802.11a**

CHANNEL	FREQUENCY (MHz)	26dBc BANDWIDTH (MHz)			PASS / FAIL
		CHAIN 0	CHAIN 1	CHAIN 2	
36	5180	20.30	19.74	19.96	PASS
40	5200	19.47	19.21	19.48	PASS
48	5240	20.51	18.92	19.86	PASS

**802.11n (20MHz)**

CHANNEL	FREQUENCY (MHz)	26dBc BANDWIDTH (MHz)			PASS / FAIL
		CHAIN 0	CHAIN 1	CHAIN 2	
36	5180	20.52	21.01	20.04	PASS
40	5200	20.70	20.89	20.11	PASS
48	5240	20.83	20.84	20.42	PASS

**802.11n (40MHz)**

CHANNEL	FREQUENCY (MHz)	26dBc BANDWIDTH (MHz)			PASS / FAIL
		CHAIN 0	CHAIN 1	CHAIN 2	
38	5190	49.15	45.05	46.78	PASS
46	5230	47.55	45.22	45.54	PASS



A D T

### SPECTRUM PLOT OF WORST VALUE

#### 802.11a

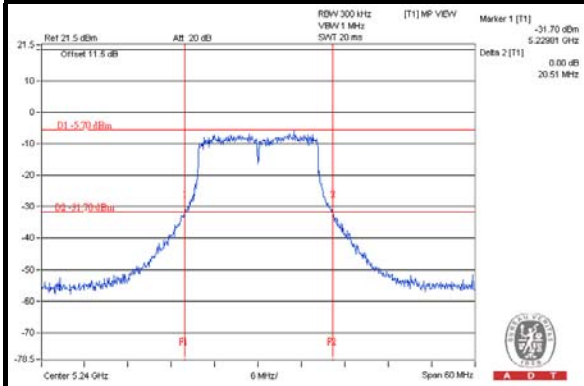

#### 802.11n (20MHz)

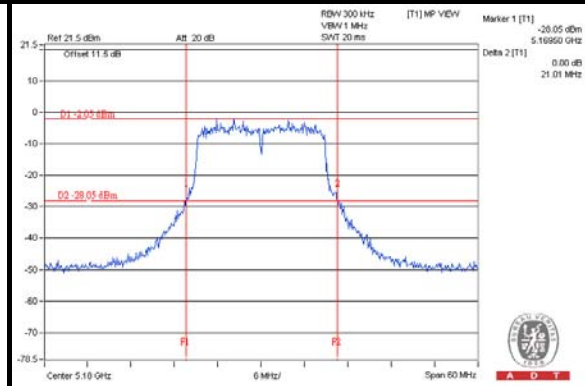

#### 802.11n (40MHz)

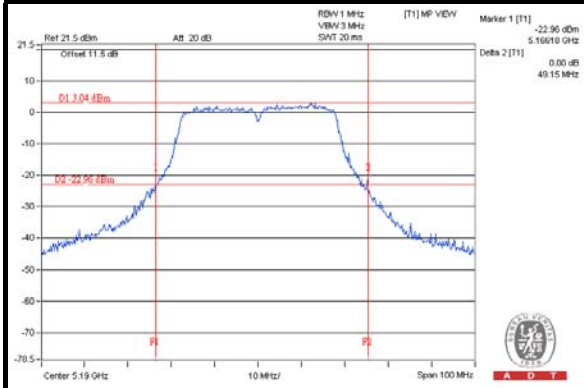

#### 4.4 PEAK POWER SPECTRAL DENSITY MEASUREMENT

##### 4.4.1 LIMITS OF PEAK POWER SPECTRAL DENSITY MEASUREMENT

FREQUENCY BAND	LIMIT
5.15 ~ 5.25GHz	4dBm

##### 4.4.2 TEST SETUP

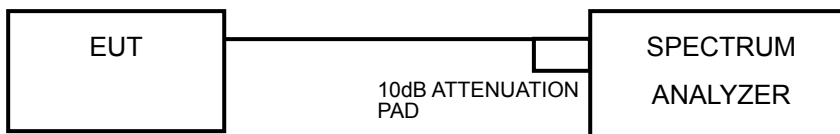

##### 4.4.3 TEST INSTRUMENTS

Refer to section 4.1.3 to get information of above instrument.

##### 4.4.4 TEST PROCEDURES

Using method SA-2

- 1) Set span to encompass the entire emission bandwidth (EBW) of the signal.
- 2) Set RBW = 30 KHz, Set VBW  $\geq$  1 MHz, Detector = RMS
- 3) Set Channel power measure = 1MHz
- 4) Sweep time = auto, trigger set to "free run".
- 5) Trace average at least 100 traces in power averaging mode.
- 6) Record the max value and add  $10 \log (1/\text{duty cycle})$

##### 4.4.5 DEVIATION FROM TEST STANDARD

No deviation.

##### 4.4.6 EUT OPERATING CONDITIONS

Same as 4.3.6.

#### 4.4.7 TEST RESULTS

##### 802.11a

CHAN.	FREQ. (MHz)	PSD (dBm)			TOTAL PSD W/O DUTY FACTOR (dBm)	DUTY FACTOR	TOTAL PSD WITH DUTY FACTOR (dBm)	MAX. LIMIT (dBm)	PASS / FAIL
		CHAIN 0	CHAIN 1	CHAIN 2					
36	5180	-5.03	-4.81	-4.26	0.08	0.10	0.18	0.23	PASS
40	5200	-5.27	-5.17	-4.01	-0.01	0.10	0.09	0.23	PASS
48	5240	-4.93	-5.02	-4.40	0.00	0.10	0.10	0.23	PASS

**NOTE:**

1. Method 1 of power density measurement of KDB 662911 is using for calculating total power density. Total power density is summing entire spectra across corresponding frequency bins on the various outputs by computer.
2. Directional gain =  $5\text{dBi} + 10\log(3) = 9.77\text{dBi} > 6\text{dBi}$  , so the power density limit shall be reduced to  $4-(9.77-6) = 0.23\text{dBm}$ .
3. Refer to section 3.3 for duty cycle spectrum plot.

##### 802.11n (20MHz)

CHAN.	FREQ. (MHz)	PSD (dBm)			TOTAL PSD W/O DUTY FACTOR (dBm)	DUTY FACTOR	TOTAL PSD WITH DUTY FACTOR (dBm)	MAX. LIMIT (dBm)	PASS / FAIL
		CHAIN 0	CHAIN 1	CHAIN 2					
36	5180	-5.32	-5.96	-3.80	-0.16	0.28	0.12	4	PASS
40	5200	-4.39	-5.88	-3.90	0.13	0.28	0.41	4	PASS
48	5240	-2.48	-3.68	-1.91	2.14	0.28	2.42	4	PASS

**NOTE:**

1. Method 1 of power density measurement of KDB 662911 is using for calculating total power density. Total power density is summing entire spectra across corresponding frequency bins on the various outputs by computer.
2. 802.11n transmit signals are completely uncorrelated.
3. Directional gain =  $5\text{dBi} + 10\log(3/3) = 5\text{dBi} < 6\text{dBi}$ , so the power density limit no need to reduced.
4. Refer to section 3.3 for duty cycle spectrum plot.

**802.11n (40MHz)**

CHAN.	FREQ. (MHz)	PSD (dBm)			TOTAL PSD W/O DUTY FACTOR (dBm)	DUTY FACTOR	TOTAL PSD WITH DUTY FACTOR (dBm)	MAX. LIMIT (dBm)	PASS / FAIL
		CHAIN 0	CHAIN 1	CHAIN 2					
38	5190	-5.67	-7.01	-4.93	-1.02	0.42	-0.60	4	PASS
46	5230	-5.42	-6.82	-5.15	-0.97	0.42	-0.55	4	PASS

**NOTE:**

1. Method 1 of power density measurement of KDB 662911 is using for calculating total power density. Total power density is summing entire spectra across corresponding frequency bins on the various outputs by computer.
2. 802.11n transmit signals are completely uncorrelated.
3. Directional gain =  $5\text{dBi} + 10\log(3/3) = 5\text{dBi} < 6\text{dBi}$ , so the power density limit no need to reduced.
4. Refer to section 3.3 for duty cycle spectrum plot.





A D T

### SPECTRUM PLOT OF WORST VALUE

#### 802.11a

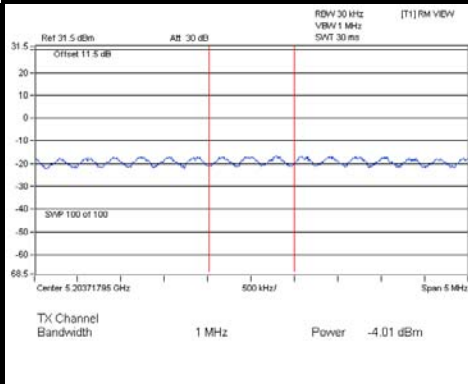

#### 802.11n (20MHz)

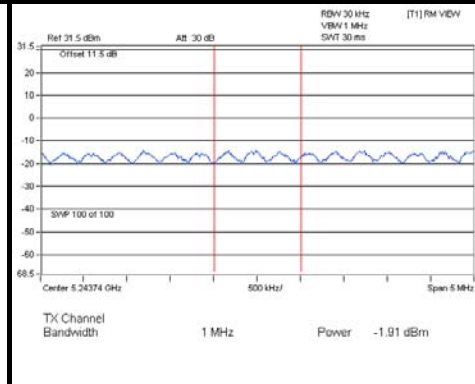

#### 802.11n (40MHz)

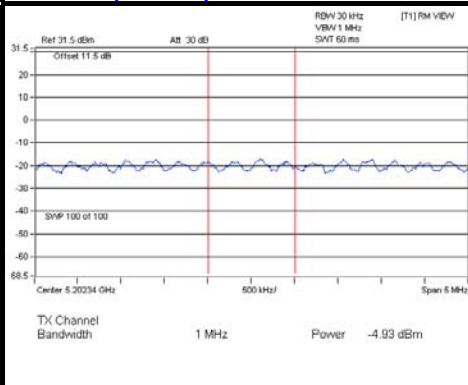

## 4.5 PEAK POWER EXCURSION MEASUREMENT

### 4.5.1 LIMITS OF PEAK POWER EXCURSION MEASUREMENT

Shall not exceed 13 dB

### 4.5.2 TEST SETUP



### 4.5.3 TEST INSTRUMENTS

Refer to section 4.1.3 to get information of above instrument.

### 4.5.4 TEST PROCEDURE

- 1) Set RBW = 1 MHz, VBW  $\geq$  3 MHz, Detector = peak.
- 2) Trace mode = max-hold. Allow the sweeps to continue until the trace stabilizes.
- 3) Use the peak search function to find the peak of the spectrum.
- 4) Measure the PPSD.
- 5) Compute the ratio of the maximum of the peak-max-hold spectrum to the PPSD. Find the worst channel and modulation mode as above test procedure, and follow KDB 789033 D01 General UNII Test Procedures v01r03 and repeat step 1 to 5 for final testing of each modulation mode on a single channel (all modulation types) in a single operating band to compliance with the peak excursion requirement.

#### 4.5.5 DEVIATION FROM TEST STANDARD

No deviation.

#### 4.5.6 EUT OPERATING CONDITIONS

Same as 4.2.6



### 4.5.7 TEST RESULTS

MODULATION MODE	MODULATION TYPE	FREQ. (MHz)	PEAK VALUE (dBm)	PPSD WITHOUT DUTY FACTOR (dBm)	PPSD WITH DUTY FACTOR (dBm)	PEAK EXCURSION (dB)	LIMIT (dB)	PASS /FAIL
802.11a	BPSK	5240	4.90	-4.40	-4.30	9.20	13	PASS
	QPSK		3.50	-4.69	-4.50	8.00	13	PASS
	16QAM		3.66	-5.12	-4.75	8.41	13	PASS
	64QAM		4.87	-5.30	-4.62	9.49	13	PASS
802.11n (20MHz)	BPSK	5240	7.99	-1.91	-1.63	9.62	13	PASS
	QPSK		7.68	-2.08	-1.56	9.24	13	PASS
	16QAM		6.86	-2.19	-1.32	8.18	13	PASS
	64QAM		7.17	-2.22	-0.90	8.07	13	PASS
802.11n (40MHz)	BPSK	5230	4.77	-5.15	-4.73	9.50	13	PASS
	QPSK		3.45	-5.18	-4.49	7.94	13	PASS
	16QAM		4.07	-5.22	-4.15	8.22	13	PASS
	64QAM		4.23	-5.23	-3.68	7.91	13	PASS

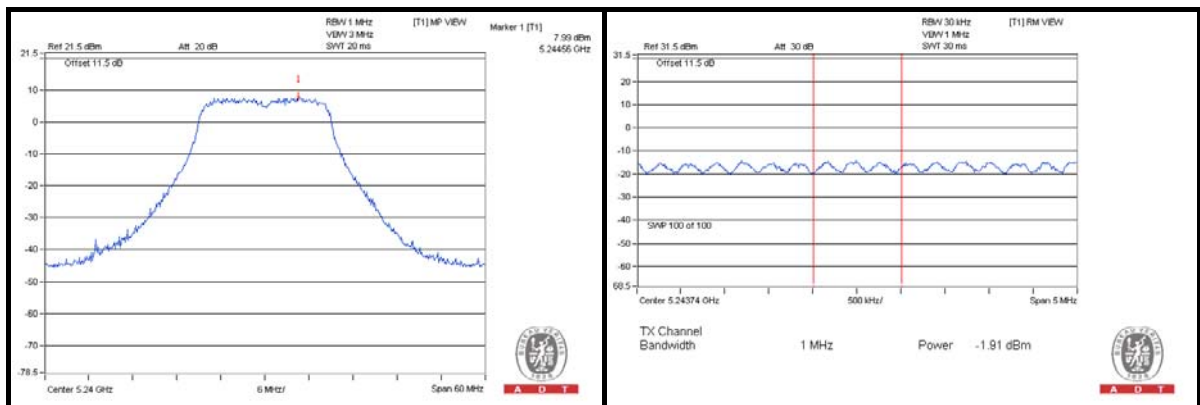

## 4.6 FREQUENCY STABILITY

### 4.6.1 LIMITS OF FREQUENCY STABILITY MEASUREMENT

The frequency of the carrier signal shall be maintained within band of operation

### 4.6.2 TEST SETUP

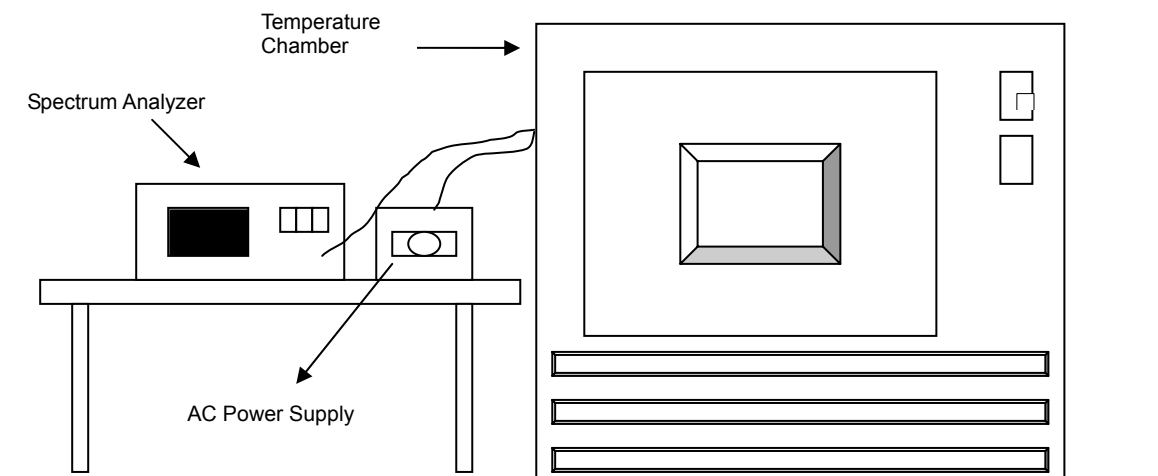

### 4.6.3 TEST INSTRUMENTS

Refer to section 4.1.3 to get information of above instrument.

#### 4.6.4 TEST PROCEDURE

- a. The EUT was placed inside the environmental test chamber and powered by nominal AC voltage.
- b. Turn the EUT on and couple its output to a spectrum analyzer.
- c. Turn the EUT off and set the chamber to the highest temperature specified.
- d. Allow sufficient time (approximately 30 min) for the temperature of the chamber to stabilize, turn the EUT on and measure the operating frequency after 2, 5, and 10 minutes.
- e. Repeat step 2 and 3 with the temperature chamber set to the lowest temperature.
- f. The test chamber was allowed to stabilize at +20 degree C for a minimum of 30 minutes. The supply voltage was then adjusted on the EUT from 85% to 115% and the frequency record.

#### 4.6.5 DEVIATION FROM TEST STANDARD

No deviation.

#### 4.6.6 EUT OPERATING CONDITION

Set the EUT transmit at un-modulation mode to test frequency stability.

#### 4.6.7 TEST RESULTS

FREQUENCY STABILITY VERSUS TEMP.									
OPERATING FREQUENCY: 5200MHz									
TEMP. (°C)	POWER SUPPLY (Vac)	0 MINUTE		2 MINUTE		5 MINUTE		10 MINUTE	
		Measured Frequency (MHz)	Frequency Drift (%)	Measured Frequency (MHz)	Frequency Drift (%)	Measured Frequency (MHz)	Frequency Drift (%)	Measured Frequency (MHz)	Frequency Drift (%)
40	120	5200.0019	0.00004	5200.0004	0.00001	5200.0034	0.00007	5200.0018	0.00003
30	120	5199.9748	-0.00048	5199.9783	-0.00042	5199.9741	-0.00050	5199.9798	-0.00039
20	120	5199.9935	-0.00013	5199.9847	-0.00029	5199.9869	-0.00025	5199.9861	-0.00027
10	120	5199.988	-0.00023	5199.9891	-0.00021	5199.9944	-0.00011	5199.9857	-0.00027
0	120	5199.9958	-0.00008	5199.9941	-0.00011	5199.992	-0.00015	5199.9972	-0.00005

FREQUENCY STABILITY VERSUS VOLTAGE									
OPERATING FREQUENCY: 5200MHz									
TEMP. (°C)	POWER SUPPLY (Vac)	0 MINUTE		2 MINUTE		5 MINUTE		10 MINUTE	
		Measured Frequency (MHz)	Frequency Drift (%)	Measured Frequency (MHz)	Frequency Drift (%)	Measured Frequency (MHz)	Frequency Drift (%)	Measured Frequency (MHz)	Frequency Drift (%)
20	138	5199.9928	-0.00014	5199.9852	-0.00028	5199.9863	-0.00026	5199.9866	-0.00026
	120	5199.9935	-0.00013	5199.9847	-0.00029	5199.9869	-0.00025	5199.9861	-0.00027
	102	5199.9936	-0.00012	5199.9851	-0.00029	5199.9873	-0.00024	5199.9864	-0.00026

## 5. PHOTOGRAPHS OF THE TEST CONFIGURATION

Please refer to the attached file (Test Setup Photo).





## 6. INFORMATION ON THE TESTING LABORATORIES

We, Bureau Veritas Consumer Products Services (H.K.) Ltd., Taoyuan Branch, were founded in 1988 to provide our best service in EMC, Radio, Telecom and Safety consultation. Our laboratories are accredited and approved according to ISO/IEC 17025.

If you have any comments, please feel free to contact us at the following:

**Linko EMC/RF Lab:**

Tel: 886-2-26052180

Fax: 886-2-26051924

**Hsin Chu EMC/RF Lab:**

Tel: 886-3-5935343

Fax: 886-3-5935342

**Hwa Ya EMC/RF/Safety Telecom Lab:**

Tel: 886-3-3183232

Fax: 886-3-3270892

**Email:** [service.adt@tw.bureauveritas.com](mailto:service.adt@tw.bureauveritas.com)

**Web Site:** [www.bureauveritas-adt.com](http://www.bureauveritas-adt.com)

The address and road map of all our labs can be found in our web site also.

## **7. APPENDIX A – MODIFICATIONS RECORDERS FOR ENGINEERING CHANGES TO THE EUT BY THE LAB**

No modifications were made to the EUT by the lab during the test.

**---END---**