



A D T

FCC TEST REPORT (CO-LOCATED)

REPORT NO.: RF131230C23-2
MODEL NO.: EAP900H, EWS320AP
FCC ID: A8J-EAP900H
RECEIVED: Nov. 26, 2013
TESTED: Jan. 08, 2014
ISSUED: Jan. 24, 2014

APPLICANT: EnGenius Technologies

ADDRESS: 1580 Scenic Avenue, Costa Mesa, CA92626

ISSUED BY: Bureau Veritas Consumer Products Services
(H.K.) Ltd., Taoyuan Branch

LAB ADDRESS: No. 47, 14th Ling, Chia Pau Vil., Lin Kou Dist.,
New Taipei City, Taiwan, R.O.C.

TEST LOCATION: No. 19, Hwa Ya 2nd Rd, Wen Hwa Tsuen, Kwei
Shan Hsiang, Taoyuan Hsien 333, Taiwan, R.O.C.

This report should not be used by the client to claim product certification, approval, or endorsement by TAF or any government agencies.



This report is for your exclusive use. Any copying or replication of this report to or for any other person or entity, or use of our name or trademark, is permitted only with our prior written permission. This report sets forth our findings solely with respect to the test samples identified herein. The results set forth in this report are not indicative or representative of the quality or characteristics of the lot from which a test sample was taken or any similar or identical product unless specifically and expressly noted. Our report includes all of the tests requested by you and the results thereof based upon the information that you provided to us. You have 60 days from date of issuance of this report to notify us of any material error or omission caused by our negligence, provided, however, that such notice shall be in writing and shall specifically address the issue you wish to raise. A failure to raise such issue within the prescribed time shall constitute your unqualified acceptance of the completeness of this report, the tests conducted and the correctness of the report contents. Unless specific mention, the uncertainty of measurement has been explicitly taken into account to declare the compliance or non-compliance to the specification.



A D T

TABLE OF CONTENTS

RELEASE CONTROL RECORD	3
1. CERTIFICATION	4
2. SUMMARY OF TEST RESULTS	5
2.1 MEASUREMENT UNCERTAINTY	5
3. GENERAL INFORMATION	6
3.1 GENERAL DESCRIPTION OF EUT	6
3.2 DESCRIPTION OF TEST MODES	8
3.2.1 TEST MODE APPLICABILITY AND TESTED CHANNEL DETAIL	9
3.3 DESCRIPTION OF SUPPORT UNITS	11
3.3.1 CONFIGURATION OF SYSTEM UNDER TEST	12
3.4 GENERAL DESCRIPTION OF APPLIED STANDARDS	13
4. TEST TYPES AND RESULTS	14
4.1 RADIATED EMISSION AND BANDEDGE MEASUREMENT	14
4.1.1 LIMITS OF RADIATED EMISSION AND BANDEDGE MEASUREMENT	14
4.1.2 LIMITS OF UNWANTED EMISSION OUT OF THE RESTRICTED BANDS	14
4.1.3 TEST INSTRUMENTS	15
4.1.4 TEST PROCEDURES	16
4.1.5 DEVIATION FROM TEST STANDARD	16
4.1.6 TEST SETUP	17
4.1.7 EUT OPERATING CONDITIONS	18
4.1.8 TEST RESULTS	19
4.2 CONDUCTED EMISSION MEASUREMENT	27
4.2.1 LIMITS OF CONDUCTED EMISSION MEASUREMENT	27
4.2.2 TEST INSTRUMENTS	27
4.2.3 TEST PROCEDURES	28
4.2.4 DEVIATION FROM TEST STANDARD	28
4.2.5 TEST SETUP	29
4.2.6 EUT OPERATING CONDITIONS	29
4.2.7 TEST RESULTS	30
5. PHOTOGRAPHS OF THE TEST CONFIGURATION	38
6. INFORMATION ON THE TESTING LABORATORIES	39
7. APPENDIX A - MODIFICATIONS RECORDERS FOR ENGINEERING CHANGES TO THE EUT BY THE LAB	40



A D T

RELEASE CONTROL RECORD

ISSUE NO.	REASON FOR CHANGE	DATE ISSUED
RF131230C23-2	Original release	Jan. 24, 2014



A D T

1. CERTIFICATION

PRODUCT: Dual Band N900 Access Point
MODEL NO.: EAP900H, EWS320AP
BRAND: EnGenius
APPLICANT: EnGenius Technologies
TESTED: Jan. 08, 2014
TEST SAMPLE: ENGINEERING SAMPLE
STANDARDS: **FCC Part 15, Subpart C (Section 15.247)**
FCC Part 15, Subpart E (Section 15.407)
ANSI C63.10-2009

The above equipment (model: EAP900H) has been tested by **Bureau Veritas Consumer Products Services (H.K.) Ltd., Taoyuan Branch**, and found compliance with the requirement of the above standards. The test record, data evaluation & Equipment Under Test (EUT) configurations represented herein are true and accurate accounts of the measurements of the sample's EMC characteristics under the conditions specified in this report.

PREPARED BY : Celine Chou , **DATE** : Jan. 24, 2014
Celine Chou / Specialist

APPROVED BY : Ken Liu , **DATE** : Jan. 24, 2014
Ken Liu / Senior Manager



A D T

2. SUMMARY OF TEST RESULTS

The EUT has been tested according to the following specifications:

APPLIED STANDARD: FCC PART 15, SUBPART C (SECTION 15.247) FCC PART 15, SUBPART E (SECTION 15.407)			
STANDARD SECTION	TEST TYPE AND LIMIT	RESULT	REMARK
15.207 15.407(b)(6)	AC Power Conducted Emission	PASS	Meet the requirement of limit. Minimum passing margin is -7.60dB at 0.47039MHz.
15.247(d) 15.407(b/1/2/3) (b)(6)	Radiated Emissions	PASS	Meet the requirement of limit. Minimum passing margin is -1.0dB at 2371.00MHz.

2.1 MEASUREMENT UNCERTAINTY

Where relevant, the following measurement uncertainty levels have been estimated for tests performed on the EUT as specified in CISPR 16-4-2:

MEASUREMENT	FREQUENCY	UNCERTAINTY
Conducted emissions	9kHz ~ 30MHz	2.44 dB
Radiated emissions	30MHz ~ 200MHz	3.34 dB
	200MHz ~ 1000MHz	3.35 dB
	1GHz ~ 18GHz	2.26 dB
	18GHz ~ 40GHz	1.94 dB

This uncertainty represents an expanded uncertainty expressed at approximately the 95% confidence level using a coverage factor of $k = 2$.



A D T

3. GENERAL INFORMATION

3.1 GENERAL DESCRIPTION OF EUT

EUT	Dual Band N900 Access Point
MODEL NO.	EAP900H, EWS320AP
POWER SUPPLY	12Vdc (Adapter) 48Vdc (PoE)
MODULATION TYPE	CCK, DQPSK, DBPSK for DSSS 64QAM, 16QAM, QPSK, BPSK for OFDM
MODULATION TECHNOLOGY	DSSS, OFDM
TRANSFER RATE	802.11b: 11.0/ 5.5/ 2.0/ 1.0Mbps 802.11g: 54.0/ 48.0/ 36.0/ 24.0/ 18.0/ 12.0/ 9.0/ 6.0Mbps 802.11a: 54.0/ 48.0/ 36.0/ 24.0/ 18.0/ 12.0/ 9.0/ 6.0Mbps 802.11n: up to 450.0Mbps
OPERATING FREQUENCY	2.4GHz: 2412 ~ 2462MHz 5.0GHz: 5180 ~ 5240MHz, 5745 ~ 5825MHz
NUMBER OF CHANNEL	2.4GHz: 11 for 802.11b, 802.11g, 802.11n (20MHz) 7 for 802.11n (40MHz) 5.0GHz: 5180 ~ 5240MHz: 4 for 802.11a, 802.11n (20MHz) 2 for 802.11n (40MHz) 5745 ~ 5825MHz: 5 for 802.11a, 802.11n (20MHz) 2 for 802.11n (40MHz)
OUTPUT POWER	680.032mW for 2412 ~ 2462MHz 49.430mW for 5180 ~ 5240MHz 992.768mW for 5745 ~ 5825MHz
ANTENNA TYPE	For 2.4GHz: PIFA antenna with 4.0dBi gain For 5.0GHz: PIFA antenna with 5.0dBi gain
ANTENNA CONNECTOR	IPEX
DATA CABLE	N/A
I/O PORTS	Refer to user's manual
ACCESSORY DEVICES	Adapter

NOTE:

1. The models as below are identical to each other except for their outward appearance due to marketing purpose.

BRAND	MODEL
EnGenius	EAP900H
	EWS320AP

* The model of the EAP900H was chosen for final test.



A D T

2. The EUT incorporates a MIMO function. Physically, the EUT provides 3 completed transmitters and 3 receivers.

MODULATION MODE	TX FUNCTION
802.11b	3TX
802.11g	3TX
802.11a	3TX
802.11n (20MHz) MCS 0-7	1TX
802.11n (20MHz) MCS 8-15	2TX
802.11n (20MHz) MCS 16-23	3TX
802.11n (40MHz) MCS 0-7	1TX
802.11n (40MHz) MCS 8-15	2TX
802.11n (40MHz) MCS 16-23	3TX

3. The EUT consumes power from the following adapter and POE.

ADAPTER	
BRAND:	Powertron Electronics Corp.
MODEL:	PA1024-2HUB PA1024-2HU PA1024-120HUB200
INPUT:	100-240Vac, 50-60Hz, 0.6A
OUTPUT:	12Vdc, 2.0A, 24W Max
POWER LINE:	1.5m cable with 1 core attached on adapter

ADAPTER FOR POE (SUPPORT UNIT)	
BRAND:	Powertron Electronics Corp.
MODEL:	PA1040-480IB080
INPUT:	100-240Vac, 50-60Hz, 1.5A
OUTPUT:	48Vdc, 0.8A, 38.4W Max
POWER LINE:	1.5m cable with 1 core attached on adapter

POE (SUPPORT UNIT)	
BRAND:	EnGenius
MODEL:	NPE-7530G
POWER RATING:	48Vdc

4. The above EUT information was declared by the manufacturer and for more detailed features description, please refer to the manufacturer's specifications or User's Manual.



3.2 DESCRIPTION OF TEST MODES

FOR 2412 ~ 2462MHz:

11 channels are provided for 802.11b, 802.11g and 802.11n (20MHz):

CHANNEL	FREQUENCY	CHANNEL	FREQUENCY
1	2412MHz	7	2442MHz
2	2417MHz	8	2447MHz
3	2422MHz	9	2452MHz
4	2427MHz	10	2457MHz
5	2432MHz	11	2462MHz
6	2437MHz		

7 channels are provided for 802.11n (40MHz):

CHANNEL	FREQUENCY	CHANNEL	FREQUENCY
3	2422MHz	7	2442MHz
4	2427MHz	8	2447MHz
5	2432MHz	9	2452MHz

FOR 5180 ~ 5240MHz

4 channels are provided for 802.11a, 802.11n (20MHz):

CHANNEL	FREQUENCY	CHANNEL	FREQUENCY
36	5180 MHz	44	5220 MHz
40	5200 MHz	48	5240 MHz

2 channels are provided for 802.11n (40MHz):

CHANNEL	FREQUENCY	CHANNEL	FREQUENCY
38	5190 MHz	46	5230 MHz

FOR 5745 ~ 5825MHz:

5 channels are provided for 802.11a, 802.11n (20MHz):

CHANNEL	FREQUENCY	CHANNEL	FREQUENCY
149	5745MHz	161	5805MHz
153	5765MHz	165	5825MHz
157	5785MHz		

2 channels are provided for 802.11n (40MHz):

CHANNEL	FREQUENCY	CHANNEL	FREQUENCY
151	5755MHz	159	5795MHz



3.2.1 TEST MODE APPLICABILITY AND TESTED CHANNEL DETAIL

EUT CONFIGURE MODE	APPLICABLE TO			DESCRIPTION
	RE \geq 1G	RE $<$ 1G	PLC	
A	√	√	√	Powered by adapter
B	-	√	√	Powered by POE

Where **RE \geq 1G**: Radiated Emission above 1GHz **RE $<$ 1G**: Radiated Emission below 1GHz
PLC: Power Line Conducted Emission

NOTE: "-" means no effect.

RADIATED EMISSION TEST (ABOVE 1GHz):

- Pre-Scan has been conducted to determine the worst-case mode from all possible combinations between available modulations, data rates and antenna ports (if EUT with antenna diversity architecture).
- Following channel(s) was (were) selected for the final test as listed below.

EUT CONFIGURE MODE	MODE	FREQ. RANGE (MHz)	AVAILABLE CHANNEL	TESTED CHANNEL	MODULATION TECHNOLOGY
A	802.11b + 802.11n (20MHz)	2412 ~ 2462	1 to 11	1 + 48	DBPSK
		5180 ~ 5240	36 to 48		BPSK
A	802.11b + 802.11n (20MHz)	2412 ~ 2462	1 to 11	1 + 157	DBPSK
		5745 ~ 5825	149 to 165		BPSK

RADIATED EMISSION TEST (BELOW 1GHz):

- Pre-Scan has been conducted to determine the worst-case mode from all possible combinations between available modulations, data rates and antenna ports (if EUT with antenna diversity architecture).
- Following channel(s) was (were) selected for the final test as listed below.

EUT CONFIGURE MODE	MODE	FREQ. RANGE (MHz)	AVAILABLE CHANNEL	TESTED CHANNEL	MODULATION TECHNOLOGY
A & B	802.11b + 802.11n (20MHz)	2412 ~ 2462	1 to 11	1 + 48	DBPSK
		5180 ~ 5240	36 to 48		BPSK
A & B	802.11b + 802.11n (20MHz)	2412 ~ 2462	1 to 11	1 + 157	DBPSK
		5745 ~ 5825	149 to 165		BPSK



A D T

CONDUCTED EMISSION TEST:

- Pre-Scan has been conducted to determine the worst-case mode from all possible combinations between available modulations, data rates and antenna ports (if EUT with antenna diversity architecture).
- Following channel(s) was (were) selected for the final test as listed below.

EUT CONFIGURE MODE	MODE	FREQ. RANGE (MHz)	AVAILABLE CHANNEL	TESTED CHANNEL	MODULATION TECHNOLOGY
A & B	802.11b + 802.11n (20MHz)	2412 ~ 2462	1 to 11	1 + 48	DBPSK
		5180 ~ 5240	36 to 48		BPSK
A & B	802.11b + 802.11n (20MHz)	2412 ~ 2462	1 to 11	1 + 157	DBPSK
		5745 ~ 5825	149 to 165		BPSK

TEST CONDITION:

APPLICABLE TO	ENVIRONMENTAL CONDITIONS	INPUT POWER	TESTED BY
RE≥1G	25deg. C, 65%RH	120Vac, 60Hz	Chris Lin
RE<1G	25deg. C, 65%RH	120Vac, 60Hz 48Vdc	Chris Lin
PLC	25deg. C, 65%RH	120Vac, 60Hz 48Vdc	Chris Lin



A D T

3.3 DESCRIPTION OF SUPPORT UNITS

The EUT has been tested as an independent unit together with other necessary accessories or support units. The following support units or accessories were used to form a representative test configuration during the tests.

NO.	PRODUCT	BRAND	MODEL NO.	SERIAL NO.	FCC ID
1	NOTEBOOK	DELL	D531	CN-0XM006-4864 3-81U-2610	QDS-BRCM1020
2	POE	EnGenius	NPE-7530G	NA	NA
3	ADAPTER	Powertron Electronics Corp.	PA1040-480IB080	NA	NA

NO.	SIGNAL CABLE DESCRIPTION OF THE ABOVE SUPPORT UNITS
1	10m RJ45 UTP cable for test mode A, 1.8m RJ45 UTP cable for test mode B
2	10m RJ45 UTP cable
3	NA

NOTE:

1. All power cords of the above support units are non-shielded (1.8 m).
2. Item 1 acted as a communication partner to transfer data.
3. Items 2-3 were provided by the manufacturer.

3.3.1 CONFIGURATION OF SYSTEM UNDER TEST

TEST MODE A

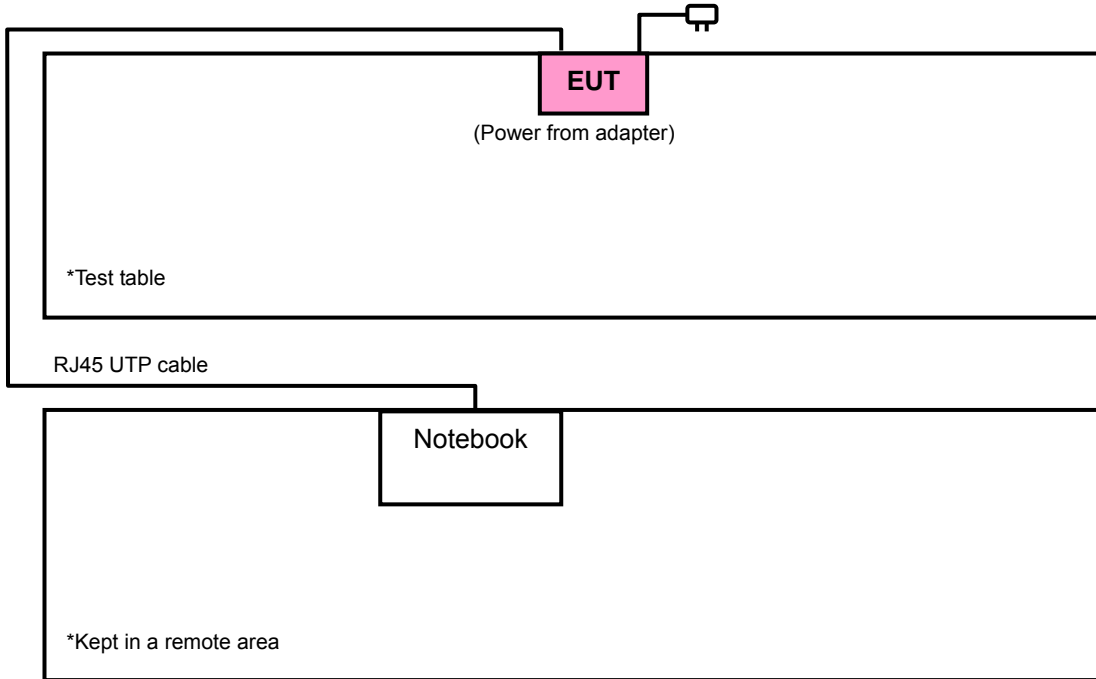

TEST MODE B

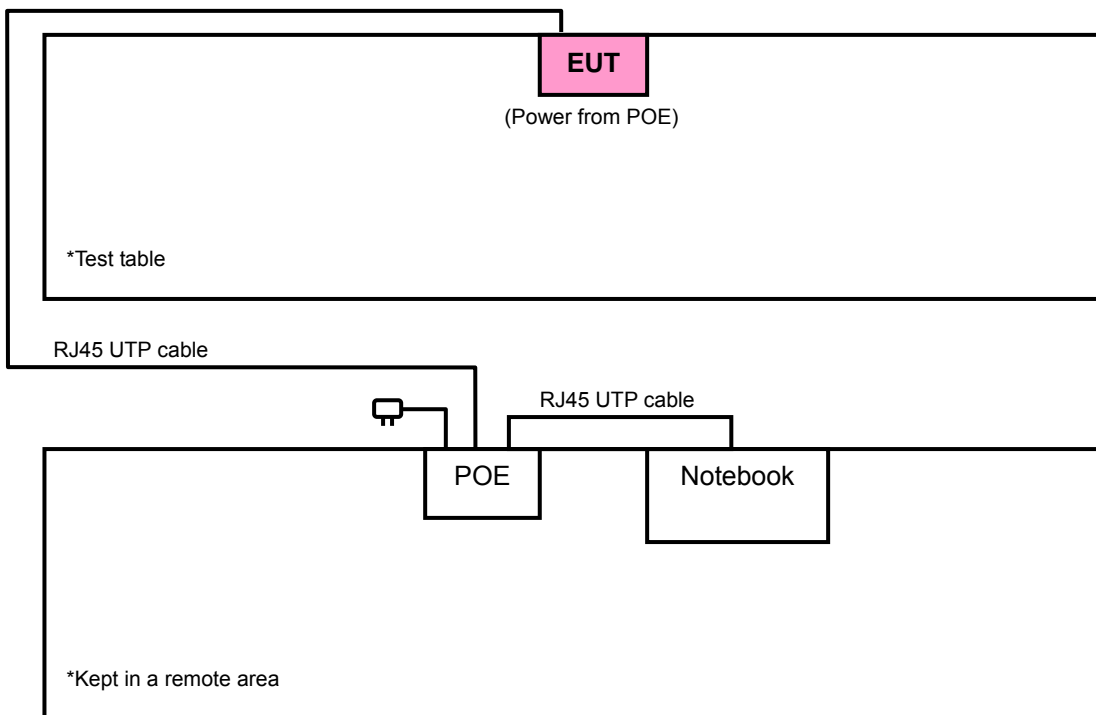



A D T

3.4 GENERAL DESCRIPTION OF APPLIED STANDARDS

The EUT is a RF Product. According to the specifications of the manufacturer, it must comply with the requirements of the following standards:

FCC Part 15, Subpart C (Section 15.247)

FCC Part 15, Subpart E (Section 15.407)

ANSI C63.10-2009

All test items have been performed and recorded as per the above standards.

NOTE: The EUT is also considered as a kind of computer peripheral, because the connection to computer is necessary for typical use. It has been verified to comply with the requirements of FCC Part 15, Subpart B, Class B (DoC). The test report has been issued separately.



4. TEST TYPES AND RESULTS

4.1 RADIATED EMISSION AND BANDEDGE MEASUREMENT

4.1.1 LIMITS OF RADIATED EMISSION AND BANDEDGE MEASUREMENT

Emissions radiated outside of the specified bands, shall be according to the general radiated limits in 15.209 as following:

FREQUENCIES (MHz)	FIELD STRENGTH (microvolts/meter)	MEASUREMENT DISTANCE (meters)
0.009 ~ 0.490	2400/F(kHz)	300
0.490 ~ 1.705	24000/F(kHz)	30
1.705 ~ 30.0	30	30
30 ~ 88	100	3
88 ~ 216	150	3
216 ~ 960	200	3
Above 960	500	3

NOTE:

1. The lower limit shall apply at the transition frequencies.
2. Emission level (dBuV/m) = 20 log Emission level (uV/m).
3. For frequencies above 1000MHz, the field strength limits are based on average detector, however, the peak field strength of any emission shall not exceed the maximum permitted average limits, specified above by more than 20dB under any condition of modulation.

4.1.2 LIMITS OF UNWANTED EMISSION OUT OF THE RESTRICTED BANDS

APPLICABLE TO	LIMIT	
√	FIELD STRENGTH AT 3m (dBμV/m)	
	PK	AV
	74	54
	EIRP LIMIT (dBm)	EQUIVALENT FIELD STRENGTH AT 3m (dBμV/m)
	PK	PK
	-27	68.3

NOTE: The following formula is used to convert the equipment isotropic radiated power (eirp) to field strength:

$$E = \frac{1000000\sqrt{30P}}{3} \mu\text{V/m, where P is the eirp (Watts).}$$



A D T

4.1.3 TEST INSTRUMENTS

DESCRIPTION & MANUFACTURER	MODEL NO.	SERIAL NO.	DATE OF CALIBRATION	DUE DATE OF CALIBRATION
Test Receiver ROHDE & SCHWARZ	ESIB7	100187	Jan. 02, 2014	Jan. 01, 2015
Spectrum Analyzer ROHDE & SCHWARZ	FSP40	100039	Jan. 31, 2013	Jan. 30, 2014
BILOG Antenna SCHWARZBECK	VULB9168	9168-160	Mar. 20, 2013	Mar. 19, 2014
HORN Antenna SCHWARZBECK	9120D	209	Sep. 12, 2013	Sep. 11, 2014
HORN Antenna SCHWARZBECK	BBHA 9170	148	Jul. 15, 2013	Jul. 14, 2014
Preamplifier Agilent	8447D	2944A10633	Oct. 07, 2013	Oct. 06, 2014
Preamplifier Agilent	8449B	3008A01964	Aug. 26, 2013	Aug. 25, 2014
RF signal cable HUBER+SUHNNER	SUCOFLEX 104	214378/4	Aug. 26, 2013	Aug. 25, 2014
RF signal cable HUBER+SUHNNER	SUCOFLEX 106	12738/6+309224/ 4	Aug. 26, 2013	Aug. 25, 2014
Software BV ADT	ADT_Radiated_ V7.6.15.9.4	NA	NA	NA
Antenna Tower inn-co GmbH	MA 4000	013303	NA	NA
Antenna Tower Controller inn-co GmbH	CO2000	017303	NA	NA
Turn Table BV ADT	TT100	TT93021703	NA	NA
Turn Table Controller BV ADT	SC100	SC93021703	NA	NA
26GHz ~ 40GHz Amplifier	EM26400	815221	Oct. 18, 2013	Oct. 17, 2014
Power Sensor	MA2411B	0738404	Apr. 28, 2012	Apr. 27, 2013

- NOTE:**
1. The calibration interval of the above test instruments is 12 months and the calibrations are traceable to NML/ROC and NIST/USA.
 2. The test was performed in HwaYa Chamber 3.
 3. The horn antenna and HP preamplifier (model: 8449B) are used only for the measurement of emission frequency above 1GHz if tested.
 4. The FCC Site Registration No. is 988962.
 5. The IC Site Registration No. is IC 7450F-3.



A D T

4.1.4 TEST PROCEDURES

- a. The EUT was placed on the top of a rotating table 0.8 meters above the ground at a 3 meters semi-anechoic chamber. The table was rotated 360 degrees to determine the position of the highest radiation.
- b. The EUT was set 3 meters away from the interference-receiving antenna, which was mounted on the top of a variable-height antenna tower.
- c. The antenna is a broadband antenna, and its height is varied from one meter to four meters above the ground to determine the maximum value of the field strength. Both horizontal and vertical polarizations of the antenna are set to make the measurement.
- d. For each suspected emission, the EUT was arranged to its worst case and then the antenna was tuned to heights from 1 meter to 4 meters and the rotatable table was turned from 0 degrees to 360 degrees to find the maximum reading.
- e. The test-receiver system was set to Peak Detect Function and Specified Bandwidth with Maximum Hold Mode.
- f. If the emission level of the EUT in peak mode was lower than the limit specified, then testing could be stopped and the peak values of the EUT would be reported. Otherwise the emissions would be re-tested one by one using peak, quasi-peak or average method as specified and then reported in a data sheet.

NOTE:

1. The resolution bandwidth and video bandwidth of test receiver/spectrum analyzer is 120kHz for Quasi-peak detection at frequency below 1GHz.
2. The resolution bandwidth of test receiver/spectrum analyzer is 1MHz and video bandwidth is 3MHz for Peak detection at frequency above 1GHz.
3. All modes of operation were investigated and the worst-case emissions are reported.

4.1.5 DEVIATION FROM TEST STANDARD

No deviation.

4.1.6 TEST SETUP

Frequency range 30MHz~1GHz

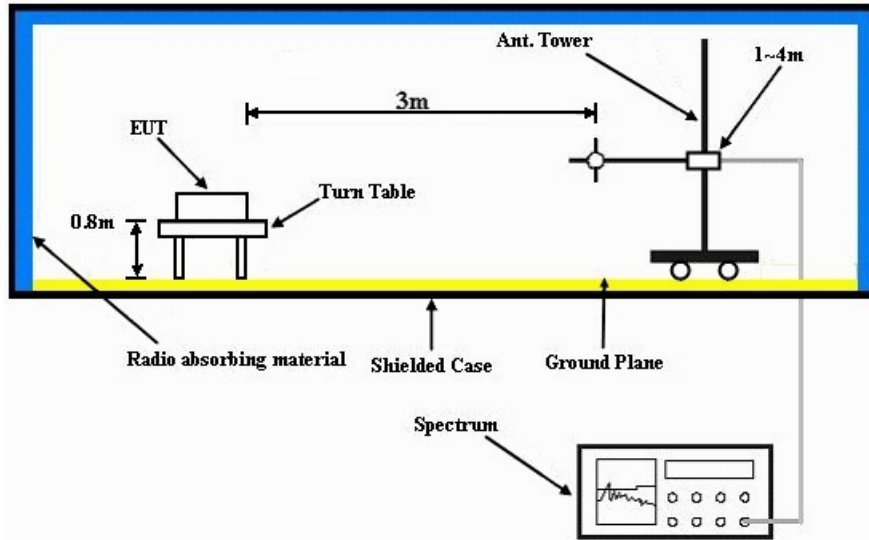

Frequency range above 1GHz

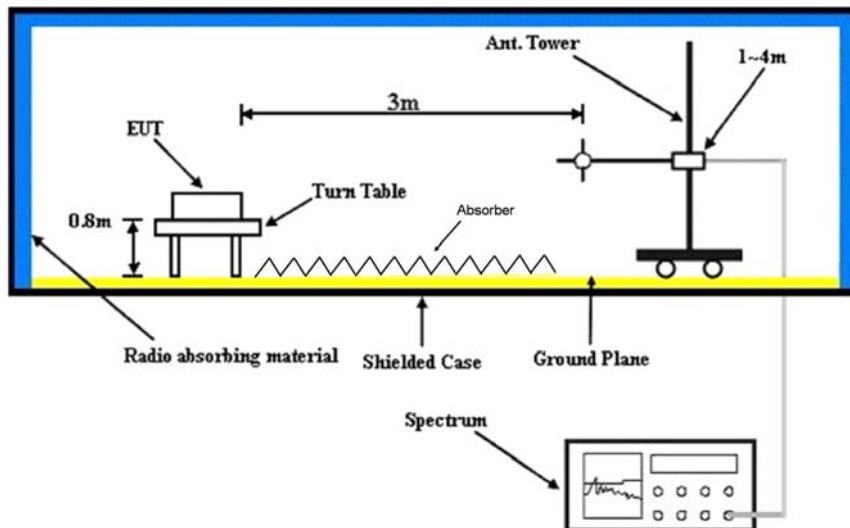

For the actual test configuration, please refer to the attached file (Test Setup Photo).



A D T

4.1.7 EUT OPERATING CONDITIONS

- a. Placed the EUT on the testing table.
- b. Prepared notebook to act as communication partner and placed it outside of testing area.
- c. The communication partner connected with EUT via a RJ45 cable and ran a test program (provided by manufacturer) to enable EUT under transmission condition continuously at specific channel frequency.
- d. The communication partner sent data to EUT by command "PING".



A D T

4.1.8 TEST RESULTS

ABOVE 1GHz DATA

802.11b+802.11n (20MHz)

EUT TEST CONDITION		MEASUREMENT DETAIL	
CHANNEL	CH 1 + CH 48	FREQUENCY RANGE	1 ~ 25GHz
INPUT POWER	120Vac, 60Hz	DETECTOR FUNCTION	Peak (PK) Average (AV)
ENVIRONMENTAL CONDITIONS	25deg. C, 65%RH	TESTED BY	Chris Lin

ANTENNA POLARITY & TEST DISTANCE: HORIZONTAL AT 3 M								
NO.	FREQ. (MHz)	EMISSION LEVEL (dBuV/m)	LIMIT (dBuV/m)	MARGIN (dB)	ANTENNA HEIGHT (m)	TABLE ANGLE (Degree)	RAW VALUE (dBuV)	CORRECTION FACTOR (dB/m)
1	2371.00	63.6 PK	74.0	-10.4	1.40 H	310	32.70	30.90
2	2371.00	52.8 AV	54.0	-1.2	1.40 H	310	21.90	30.90
3	2390.00	61.1 PK	74.0	-12.9	1.40 H	310	30.10	31.00
4	2390.00	51.2 AV	54.0	-2.8	1.40 H	310	20.20	31.00
5	*2412.00	122.7 PK			1.35 H	320	91.60	31.10
6	*2412.00	118.7 AV			1.35 H	320	87.60	31.10
7	4824.00	51.1 PK	74.0	-22.9	1.13 H	120	46.70	4.40
8	4824.00	46.7 AV	54.0	-7.3	1.13 H	120	42.30	4.40
9	*5240.00	101.8 PK			1.05 H	260	63.90	37.90
10	*5240.00	91.3 AV			1.05 H	260	53.40	37.90
11	#5350.00	58.8 PK	74.0	-15.2	1.60 H	230	53.40	5.40
12	#5350.00	47.7 AV	54.0	-6.3	1.60 H	230	42.30	5.40
13	#10480.00	61.5 PK	74.0	-12.5	1.10 H	200	43.20	18.30
14	#10480.00	48.5 AV	54.0	-5.5	1.10 H	200	30.20	18.30

REMARKS:

- Emission Level(dBuV/m) = Raw Value(dBuV) + Correction Factor(dB/m)
- Correction Factor(dB/m) = Antenna Factor(dB/m) + Cable Factor(dB) – Pre-Amplifier Factor(dB)
- The other emission levels were very low against the limit.
- Margin value = Emission Level – Limit value
- " * ": Fundamental frequency.
- "#":The radiated frequency is out the restricted band.



A D T

EUT TEST CONDITION		MEASUREMENT DETAIL	
CHANNEL	CH 1 + CH 48	FREQUENCY RANGE	1 ~ 25GHz
INPUT POWER	120Vac, 60Hz	DETECTOR FUNCTION	Peak (PK) Average (AV)
ENVIRONMENTAL CONDITIONS	25deg. C, 65%RH	TESTED BY	Chris Lin

ANTENNA POLARITY & TEST DISTANCE: VERTICAL AT 3 M								
NO.	FREQ. (MHz)	EMISSION LEVEL (dBuV/m)	LIMIT (dBuV/m)	MARGIN (dB)	ANTENNA HEIGHT (m)	TABLE ANGLE (Degree)	RAW VALUE (dBuV)	CORRECTION FACTOR (dB/m)
1	2371.00	58.5 PK	74.0	-15.5	1.40 V	10	27.60	30.90
2	2371.00	46.3 AV	54.0	-7.7	1.40 V	10	15.40	30.90
3	2390.00	57.4 PK	74.0	-16.6	1.40 V	12	26.40	31.00
4	2390.00	45.9 AV	54.0	-8.1	1.40 V	12	14.90	31.00
5	*2412.00	117.5 PK			1.30 V	340	86.40	31.10
6	*2412.00	113.5 AV			1.30 V	340	82.40	31.10
7	4824.00	52.1 PK	74.0	-21.9	1.13 V	340	47.70	4.40
8	4824.00	46.7 AV	54.0	-7.3	1.13 V	340	42.30	4.40
9	*5240.00	109.1 PK			1.05 V	170	71.20	37.90
10	*5240.00	99.2 AV			1.05 V	170	61.30	37.90
11	#5350.00	59.7 PK	74.0	-14.3	1.10 V	120	54.30	5.40
12	#5350.00	46.9 AV	54.0	-7.1	1.10 V	120	41.50	5.40
13	#10480.00	62.6 PK	74.0	-11.4	1.10 V	340	44.30	18.30
14	#10480.00	48.9 AV	54.0	-5.1	1.10 V	340	30.60	18.30

REMARKS:

1. Emission Level(dBuV/m) = Raw Value(dBuV) + Correction Factor(dB/m)
2. Correction Factor(dB/m) = Antenna Factor(dB/m) + Cable Factor(dB) – Pre-Amplifier Factor(dB)
3. The other emission levels were very low against the limit.
4. Margin value = Emission Level – Limit value
5. “ * “: Fundamental frequency.
6. “#”:The radiated frequency is out the restricted band.



A D T

EUT TEST CONDITION		MEASUREMENT DETAIL	
CHANNEL	CH 1 + CH 157	FREQUENCY RANGE	1 ~ 25GHz
INPUT POWER	120Vac, 60Hz	DETECTOR FUNCTION	Peak (PK) Average (AV)
ENVIRONMENTAL CONDITIONS	25deg. C, 65%RH	TESTED BY	Chris Lin

ANTENNA POLARITY & TEST DISTANCE: HORIZONTAL AT 3 M								
NO.	FREQ. (MHz)	EMISSION LEVEL (dBuV/m)	LIMIT (dBuV/m)	MARGIN (dB)	ANTENNA HEIGHT (m)	TABLE ANGLE (Degree)	RAW VALUE (dBuV)	CORRECTION FACTOR (dB/m)
1	2371.00	64.2 PK	74.0	-9.8	1.34 H	310	33.30	30.90
2	2371.00	53.0 AV	54.0	-1.0	1.34 H	310	22.10	30.90
3	2390.00	62.3 PK	74.0	-11.7	1.33 H	310	31.30	31.00
4	2390.00	51.1 AV	54.0	-2.9	1.33 H	310	20.10	31.00
5	*2412.00	123.2 PK			1.33 H	318	92.10	31.10
6	*2412.00	117.4 AV			1.33 H	318	86.30	31.10
7	4824.00	52.2 PK	74.0	-21.8	1.15 H	121	47.80	4.40
8	4824.00	46.5 AV	54.0	-7.5	1.15 H	121	42.10	4.40
9	5360.00	60.1 PK	74.0	-13.9	1.90 H	160	54.70	5.40
10	5360.00	49.0 AV	54.0	-5.0	1.90 H	160	43.60	5.40
11	5440.00	60.2 PK	74.0	-13.8	1.30 H	55	54.60	5.60
12	5440.00	49.2 AV	54.0	-4.8	1.30 H	55	43.60	5.60
13	*5785.00	114.2 PK			1.65 H	310	75.60	38.60
14	*5785.00	104.0 AV			1.65 H	310	65.40	38.60
15	11570.00	63.7 PK	74.0	-10.3	1.10 H	120	44.70	19.00
16	11570.00	50.6 AV	54.0	-3.4	1.10 H	120	31.60	19.00

REMARKS:

1. Emission Level(dBuV/m) = Raw Value(dBuV) + Correction Factor(dB/m)
2. Correction Factor(dB/m) = Antenna Factor(dB/m) + Cable Factor(dB) – Pre-Amplifier Factor(dB)
3. The other emission levels were very low against the limit.
4. Margin value = Emission Level – Limit value
5. “ * ”: Fundamental frequency.



A D T

EUT TEST CONDITION		MEASUREMENT DETAIL	
CHANNEL	CH 1 + CH 157	FREQUENCY RANGE	1 ~ 25GHz
INPUT POWER	120Vac, 60Hz	DETECTOR FUNCTION	Peak (PK) Average (AV)
ENVIRONMENTAL CONDITIONS	25deg. C, 65%RH	TESTED BY	Chris Lin

ANTENNA POLARITY & TEST DISTANCE: VERTICAL AT 3 M								
NO.	FREQ. (MHz)	EMISSION LEVEL (dBuV/m)	LIMIT (dBuV/m)	MARGIN (dB)	ANTENNA HEIGHT (m)	TABLE ANGLE (Degree)	RAW VALUE (dBuV)	CORRECTION FACTOR (dB/m)
1	2371.00	57.3 PK	74.0	-16.7	1.50 V	20	26.40	30.90
2	2371.00	46.3 AV	54.0	-7.7	1.50 V	20	15.40	30.90
3	2390.00	57.4 PK	74.0	-16.6	1.40 V	30	26.40	31.00
4	2390.00	46.3 AV	54.0	-7.7	1.40 V	30	15.30	31.00
5	*2412.00	117.6 PK			1.30 V	340	86.50	31.10
6	*2412.00	113.5 AV			1.30 V	340	82.40	31.10
7	4824.00	51.3 PK	74.0	-22.7	1.20 V	340	46.90	4.40
8	4824.00	47.2 AV	54.0	-6.8	1.20 V	340	42.80	4.40
9	5360.00	58.5 PK	74.0	-15.5	1.90 V	52	53.10	5.40
10	5360.00	48.0 AV	54.0	-6.0	1.90 V	52	42.60	5.40
11	5440.00	59.3 PK	74.0	-14.7	1.25 V	60	53.70	5.60
12	5440.00	49.2 AV	54.0	-4.8	1.25 V	60	43.60	5.60
13	*5785.00	114.4 PK			1.70 V	310	75.80	38.60
14	*5785.00	104.3 AV			1.70 V	310	65.70	38.60
15	11570.00	62.9 PK	74.0	-11.1	1.10 V	120	43.90	19.00
16	11570.00	50.8 AV	54.0	-3.2	1.10 V	120	31.80	19.00

REMARKS:

1. Emission Level(dBuV/m) = Raw Value(dBuV) + Correction Factor(dB/m)
2. Correction Factor(dB/m) = Antenna Factor(dB/m) + Cable Factor(dB) – Pre-Amplifier Factor(dB)
3. The other emission levels were very low against the limit.
4. Margin value = Emission Level – Limit value
5. “ * “: Fundamental frequency.



A D T

BELOW 1GHz DATA

802.11b+802.11n (20MHz)

EUT TEST CONDITION		MEASUREMENT DETAIL	
CHANNEL	CH 1 + CH 48	FREQUENCY RANGE	Below 1000MHz
INPUT POWER	120Vac, 60Hz	DETECTOR FUNCTION	Peak (PK) Average (AV)
ENVIRONMENTAL CONDITIONS	25deg. C, 65%RH	TESTED BY	Chris Lin
TEST MODE	A		

ANTENNA POLARITY & TEST DISTANCE: HORIZONTAL AT 3 M								
NO.	FREQ. (MHz)	EMISSION LEVEL (dBuV/m)	LIMIT (dBuV/m)	MARGIN (dB)	ANTENNA HEIGHT (m)	TABLE ANGLE (Degree)	RAW VALUE (dBuV)	CORRECTION FACTOR (dB/m)
1	99.75	34.2 QP	43.5	-9.3	2.00 H	297	52.90	-18.70
2	154.09	29.5 QP	43.5	-14.0	2.00 H	88	43.00	-13.50
3	311.26	32.1 QP	46.0	-13.9	1.01 H	91	44.10	-12.00
4	567.39	31.6 QP	46.0	-14.4	1.51 H	74	39.00	-7.40
5	619.78	36.3 QP	46.0	-9.7	1.51 H	16	42.00	-5.70
6	722.62	41.3 QP	46.0	-4.7	1.01 H	88	45.20	-3.90
ANTENNA POLARITY & TEST DISTANCE: VERTICAL AT 3 M								
NO.	FREQ. (MHz)	EMISSION LEVEL (dBuV/m)	LIMIT (dBuV/m)	MARGIN (dB)	ANTENNA HEIGHT (m)	TABLE ANGLE (Degree)	RAW VALUE (dBuV)	CORRECTION FACTOR (dB/m)
1	51.24	32.5 QP	40.0	-7.5	1.24 V	16	46.80	-14.30
2	212.30	29.0 QP	43.5	-14.5	1.24 V	265	45.40	-16.40
3	375.29	30.9 QP	46.0	-15.1	1.00 V	57	41.80	-10.90
4	621.72	32.2 QP	46.0	-13.8	1.00 V	144	37.80	-5.60
5	718.74	35.5 QP	46.0	-10.5	1.00 V	159	39.60	-4.10
6	872.03	37.4 QP	46.0	-8.6	1.24 V	357	38.50	-1.10

REMARKS:

1. Emission Level(dBuV/m) = Raw Value(dBuV) + Correction Factor(dB/m)
2. Correction Factor(dB/m) = Antenna Factor(dB/m) + Cable Factor(dB)
– Pre-Amplifier Factor (dB)
3. The other emission levels were very low against the limit.
4. Margin value = Emission Level – Limit value



A D T

EUT TEST CONDITION		MEASUREMENT DETAIL	
CHANNEL	CH 1 + CH 157	FREQUENCY RANGE	Below 1000MHz
INPUT POWER	120Vac, 60Hz	DETECTOR FUNCTION	Peak (PK) Average (AV)
ENVIRONMENTAL CONDITIONS	25deg. C, 65%RH	TESTED BY	Chris Lin
TEST MODE	A		

ANTENNA POLARITY & TEST DISTANCE: HORIZONTAL AT 3 M								
NO.	FREQ. (MHz)	EMISSION LEVEL (dBuV/m)	LIMIT (dBuV/m)	MARGIN (dB)	ANTENNA HEIGHT (m)	TABLE ANGLE (Degree)	RAW VALUE (dBuV)	CORRECTION FACTOR (dB/m)
1	99.75	28.1 QP	43.5	-15.4	1.25 H	132	46.80	-18.70
2	152.15	27.8 QP	43.5	-15.7	1.00 H	242	41.40	-13.60
3	319.02	32.4 QP	46.0	-13.6	1.50 H	123	44.20	-11.80
4	363.65	32.9 QP	46.0	-13.1	1.25 H	123	44.10	-11.20
5	612.02	31.5 QP	46.0	-14.5	1.00 H	81	37.30	-5.80
6	716.80	40.5 QP	46.0	-5.5	1.50 H	71	44.60	-4.10
ANTENNA POLARITY & TEST DISTANCE: VERTICAL AT 3 M								
NO.	FREQ. (MHz)	EMISSION LEVEL (dBuV/m)	LIMIT (dBuV/m)	MARGIN (dB)	ANTENNA HEIGHT (m)	TABLE ANGLE (Degree)	RAW VALUE (dBuV)	CORRECTION FACTOR (dB/m)
1	51.24	33.5 QP	40.0	-6.5	1.25 V	2	47.80	-14.30
2	91.99	28.8 QP	43.5	-14.7	1.00 V	283	48.70	-19.90
3	175.43	27.4 QP	43.5	-16.1	1.50 V	295	42.30	-14.90
4	400.52	29.9 QP	46.0	-16.1	1.00 V	171	40.40	-10.50
5	631.42	32.6 QP	46.0	-13.4	1.25 V	145	37.90	-5.30
6	701.28	35.6 QP	46.0	-10.4	1.50 V	155	40.00	-4.40

REMARKS:

1. Emission Level(dBuV/m) = Raw Value(dBuV) + Correction Factor(dB/m)
2. Correction Factor(dB/m) = Antenna Factor(dB/m) + Cable Factor(dB) – Pre-Amplifier Factor (dB)
3. The other emission levels were very low against the limit.
4. Margin value = Emission Level – Limit value



A D T

EUT TEST CONDITION		MEASUREMENT DETAIL	
CHANNEL	CH 1 + CH 48	FREQUENCY RANGE	Below 1000MHz
INPUT POWER	48Vdc	DETECTOR FUNCTION	Peak (PK) Average (AV)
ENVIRONMENTAL CONDITIONS	25deg. C, 65%RH	TESTED BY	Chris Lin
TEST MODE	B		

ANTENNA POLARITY & TEST DISTANCE: HORIZONTAL AT 3 M								
NO.	FREQ. (MHz)	EMISSION LEVEL (dBuV/m)	LIMIT (dBuV/m)	MARGIN (dB)	ANTENNA HEIGHT (m)	TABLE ANGLE (Degree)	RAW VALUE (dBuV)	CORRECTION FACTOR (dB/m)
1	99.75	34.6 QP	43.5	-8.9	1.99 H	118	53.30	-18.70
2	311.26	32.7 QP	46.0	-13.3	1.00 H	94	44.70	-12.00
3	499.48	31.4 QP	46.0	-14.6	1.99 H	118	39.70	-8.30
4	612.02	35.4 QP	46.0	-10.6	1.50 H	52	41.20	-5.80
5	666.35	36.6 QP	46.0	-9.4	1.24 H	55	41.60	-5.00
6	726.50	40.9 QP	46.0	-5.1	1.00 H	71	44.70	-3.80
ANTENNA POLARITY & TEST DISTANCE: VERTICAL AT 3 M								
NO.	FREQ. (MHz)	EMISSION LEVEL (dBuV/m)	LIMIT (dBuV/m)	MARGIN (dB)	ANTENNA HEIGHT (m)	TABLE ANGLE (Degree)	RAW VALUE (dBuV)	CORRECTION FACTOR (dB/m)
1	51.24	32.4 QP	40.0	-7.6	1.25 V	233	46.70	-14.30
2	192.89	27.8 QP	43.5	-15.7	1.00 V	347	44.40	-16.60
3	402.46	29.7 QP	46.0	-16.3	1.50 V	163	40.30	-10.60
4	643.07	32.3 QP	46.0	-13.7	1.50 V	155	37.50	-5.20
5	701.28	36.9 QP	46.0	-9.1	1.00 V	156	41.30	-4.40
6	877.85	28.4 QP	46.0	-17.6	1.25 V	34	29.40	-1.00

REMARKS:

1. Emission Level(dBuV/m) = Raw Value(dBuV) + Correction Factor(dB/m)
2. Correction Factor(dB/m) = Antenna Factor(dB/m) + Cable Factor(dB)
– Pre-Amplifier Factor (dB)
3. The other emission levels were very low against the limit.
4. Margin value = Emission Level – Limit value



A D T

EUT TEST CONDITION		MEASUREMENT DETAIL	
CHANNEL	CH 1 + CH 157	FREQUENCY RANGE	Below 1000MHz
INPUT POWER	48Vdc	DETECTOR FUNCTION	Peak (PK) Average (AV)
ENVIRONMENTAL CONDITIONS	25deg. C, 65%RH	TESTED BY	Chris Lin
TEST MODE	B		

ANTENNA POLARITY & TEST DISTANCE: HORIZONTAL AT 3 M								
NO.	FREQ. (MHz)	EMISSION LEVEL (dBuV/m)	LIMIT (dBuV/m)	MARGIN (dB)	ANTENNA HEIGHT (m)	TABLE ANGLE (Degree)	RAW VALUE (dBuV)	CORRECTION FACTOR (dB/m)
1	99.75	28.0 QP	43.5	-15.5	1.25 H	115	46.70	-18.70
2	154.09	27.3 QP	43.5	-16.2	1.00 H	105	40.80	-13.50
3	311.26	32.6 QP	46.0	-13.4	1.50 H	99	44.60	-12.00
4	388.87	31.2 QP	46.0	-14.8	1.25 H	43	41.70	-10.50
5	623.66	31.6 QP	46.0	-14.4	1.00 H	83	37.10	-5.50
6	718.74	40.5 QP	46.0	-5.5	1.50 H	64	44.60	-4.10
ANTENNA POLARITY & TEST DISTANCE: VERTICAL AT 3 M								
NO.	FREQ. (MHz)	EMISSION LEVEL (dBuV/m)	LIMIT (dBuV/m)	MARGIN (dB)	ANTENNA HEIGHT (m)	TABLE ANGLE (Degree)	RAW VALUE (dBuV)	CORRECTION FACTOR (dB/m)
1	51.24	32.3 QP	40.0	-7.7	1.25 V	266	46.60	-14.30
2	194.83	26.5 QP	43.5	-17.0	1.00 V	317	43.10	-16.60
3	313.20	27.8 QP	46.0	-18.2	1.50 V	9	39.70	-11.90
4	400.52	30.4 QP	46.0	-15.6	1.00 V	159	40.90	-10.50
5	641.13	31.9 QP	46.0	-14.1	1.25 V	153	37.10	-5.20
6	712.92	36.0 QP	46.0	-10.0	1.50 V	155	40.20	-4.20

REMARKS:

1. Emission Level(dBuV/m) = Raw Value(dBuV) + Correction Factor(dB/m)
2. Correction Factor(dB/m) = Antenna Factor(dB/m) + Cable Factor(dB) – Pre-Amplifier Factor (dB)
3. The other emission levels were very low against the limit.
4. Margin value = Emission Level – Limit value



A D T

4.2 CONDUCTED EMISSION MEASUREMENT

4.2.1 LIMITS OF CONDUCTED EMISSION MEASUREMENT

FREQUENCY OF EMISSION (MHz)	CONDUCTED LIMIT (dB μ V)	
	Quasi-peak	Average
0.15-0.5	66 to 56	56 to 46
0.5-5	56	46
5-30	60	50

- NOTE:** 1. The lower limit shall apply at the transition frequencies.
2. The limit decreases in line with the logarithm of the frequency in the range of 0.15 to 0.50 MHz.
3. All emanations from a class A/B digital device or system, including any network of conductors and apparatus connected thereto, shall not exceed the level of field strengths specified above.

4.2.2 TEST INSTRUMENTS

DESCRIPTION & MANUFACTURER	MODEL NO.	SERIAL NO.	DATE OF CALIBRATION	DUE DATE OF CALIBRATION
Test Receiver ROHDE & SCHWARZ	ESCS30	100289	Nov. 29, 2013	Nov. 28, 2014
RF signal cable Woken	5D-FB	Cable-HYC01-01	Dec. 27, 2013	Dec. 26, 2014
LISN ROHDE & SCHWARZ (Peripheral)	ESH3-Z5	100311	Jul. 17, 2013	Jul. 16, 2014
LISN ROHDE & SCHWARZ (EUT)	ESH3-Z5	835239/001	Feb. 04, 2013	Feb. 03, 2014
Software ADT	BV ADT_Cond_ V7.3.7.3	NA	NA	NA

- NOTE:** 1. The calibration interval of the above test instruments is 12 months and the calibrations are traceable to NML/ROC and NIST/USA.
2. The test was performed in HwaYa Shielded Room 1.
3. The VCCI Site Registration No. is C-2040.



A D T

4.2.3 TEST PROCEDURES

- a. The EUT was placed 0.4 meters from the conducting wall of the shielded room with EUT being connected to the power mains through a line impedance stabilization network (LISN). Other support units were connected to the power mains through another LISN. The two LISNs provide 50 ohm/ 50uH of coupling impedance for the measuring instrument.
- b. Both lines of the power mains connected to the EUT were checked for maximum conducted interference.
- c. The frequency range from 150kHz to 30MHz was searched. Emission levels under (Limit - 20dB) was not recorded.

NOTE: All modes of operation were investigated and the worst-case emissions are reported.

4.2.4 DEVIATION FROM TEST STANDARD

No deviation.

4.2.5 TEST SETUP

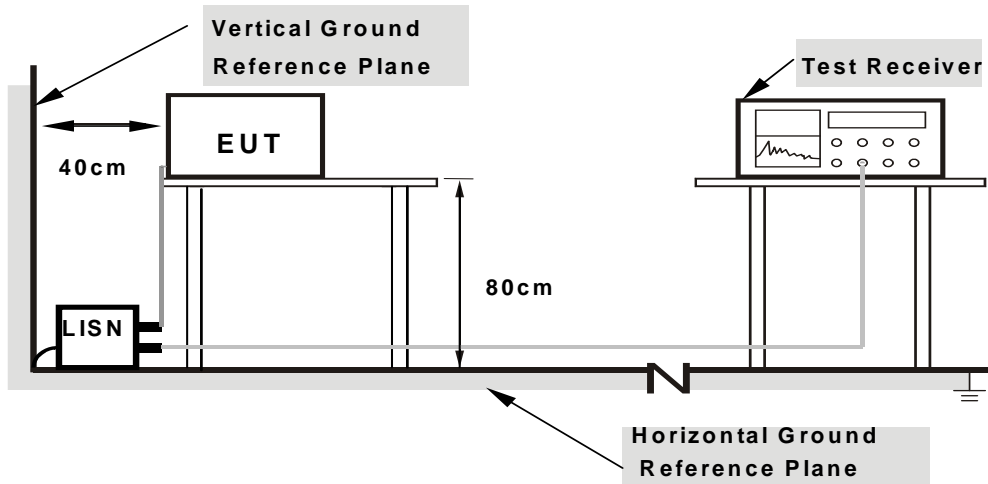

- Note:**
- 1.Support units were connected to second LISN.
 - 2.Both of LISNs (AMN) are 80 cm from EUT and at least 80 from other units and other metal planes

For the actual test configuration, please refer to the attached file (Test Setup Photo).

4.2.6 EUT OPERATING CONDITIONS

Same as 4.1.6.

4.2.7 TEST RESULTS

CONDUCTED WORST-CASE DATA:

802.11b+802.11n (20MHz)

CHANNEL	CH 1 + CH 48	6dB BANDWIDTH	9kHz
PHASE	Line 1	TEST MODE	A

No	Freq. [MHz]	Corr. Factor (dB)	Reading Value		Emission Level		Limit		Margin	
			[dB (uV)]		[dB (uV)]		[dB (uV)]		(dB)	
			Q.P.	AV.	Q.P.	AV.	Q.P.	AV.	Q.P.	AV.
1	0.17346	0.10	48.16	31.51	48.26	31.61	64.79	54.79	-16.53	-23.18
2	0.22820	0.10	43.16	29.17	43.26	29.27	62.51	52.51	-19.25	-23.24
3	0.51312	0.12	41.12	32.75	41.24	32.87	56.00	46.00	-14.76	-13.13
4	1.07276	0.14	25.85	16.09	25.99	16.23	56.00	46.00	-30.01	-29.77
5	3.99744	0.23	26.23	18.22	26.46	18.45	56.00	46.00	-29.54	-27.55
6	10.64444	0.52	26.27	19.18	26.79	19.70	60.00	50.00	-33.21	-30.30

REMARKS:

1. Q.P. and AV. are abbreviations of quasi-peak and average individually.
2. The emission levels of other frequencies were very low against the limit.
3. Margin value = Emission level - Limit value
4. Correction factor = Insertion loss + Cable loss
5. Emission Level = Correction Factor + Reading Value

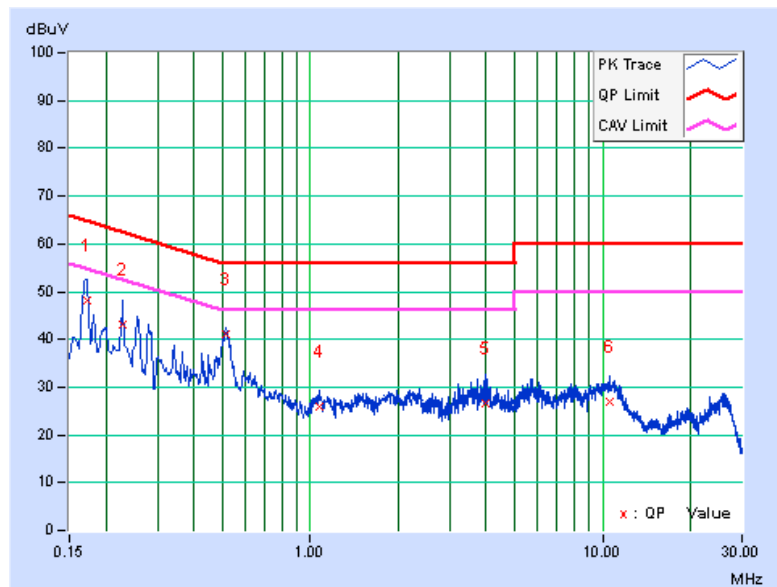



A D T

CHANNEL	CH 1 + CH 48	6dB BANDWIDTH	9kHz
PHASE	Line 2	TEST MODE	A

No	Freq. [MHz]	Corr. Factor (dB)	Reading Value		Emission Level		Limit		Margin	
			[dB (uV)]		[dB (uV)]		[dB (uV)]		(dB)	
			Q.P.	AV.	Q.P.	AV.	Q.P.	AV.	Q.P.	AV.
1	0.15782	0.11	49.68	32.28	49.79	32.39	65.58	55.58	-15.79	-23.19
2	0.22429	0.11	41.44	26.21	41.55	26.32	62.66	52.66	-21.11	-26.34
3	0.51363	0.13	39.93	31.58	40.06	31.71	56.00	46.00	-15.94	-14.29
4	1.05624	0.14	30.95	21.00	31.09	21.14	56.00	46.00	-24.91	-24.86
5	3.56343	0.20	26.33	19.07	26.53	19.27	56.00	46.00	-29.47	-26.73
6	10.61707	0.38	28.90	21.78	29.28	22.16	60.00	50.00	-30.72	-27.84

REMARKS:

1. Q.P. and AV. are abbreviations of quasi-peak and average individually.
2. The emission levels of other frequencies were very low against the limit.
3. Margin value = Emission level - Limit value
4. Correction factor = Insertion loss + Cable loss
5. Emission Level = Correction Factor + Reading Value

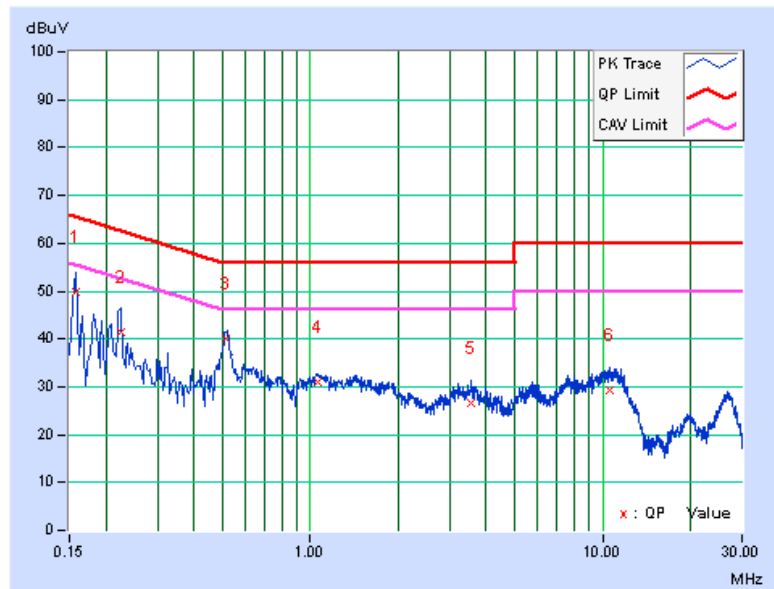



A D T

CHANNEL	CH 1 + CH 157	6dB BANDWIDTH	9kHz
PHASE	Line 1	TEST MODE	A

No	Freq.	Corr. Factor	Reading Value		Emission Level		Limit		Margin	
	[MHz]		[dB (uV)]		[dB (uV)]		[dB (uV)]		(dB)	
			Q.P.	AV.	Q.P.	AV.	Q.P.	AV.	Q.P.	AV.
1	0.16569	0.10	48.75	31.03	48.85	31.13	65.17	55.17	-16.32	-24.04
2	0.25557	0.11	42.02	29.62	42.13	29.73	61.57	51.57	-19.45	-21.85
3	0.51312	0.12	41.13	32.77	41.25	32.89	56.00	46.00	-14.75	-13.11
4	3.61035	0.22	26.36	18.54	26.58	18.76	56.00	46.00	-29.42	-27.24
5	10.24953	0.50	26.15	18.92	26.65	19.42	60.00	50.00	-33.35	-30.58
6	26.39001	1.13	21.92	14.83	23.05	15.96	60.00	50.00	-36.95	-34.04

REMARKS:

1. Q.P. and AV. are abbreviations of quasi-peak and average individually.
2. The emission levels of other frequencies were very low against the limit.
3. Margin value = Emission level - Limit value
4. Correction factor = Insertion loss + Cable loss
5. Emission Level = Correction Factor + Reading Value

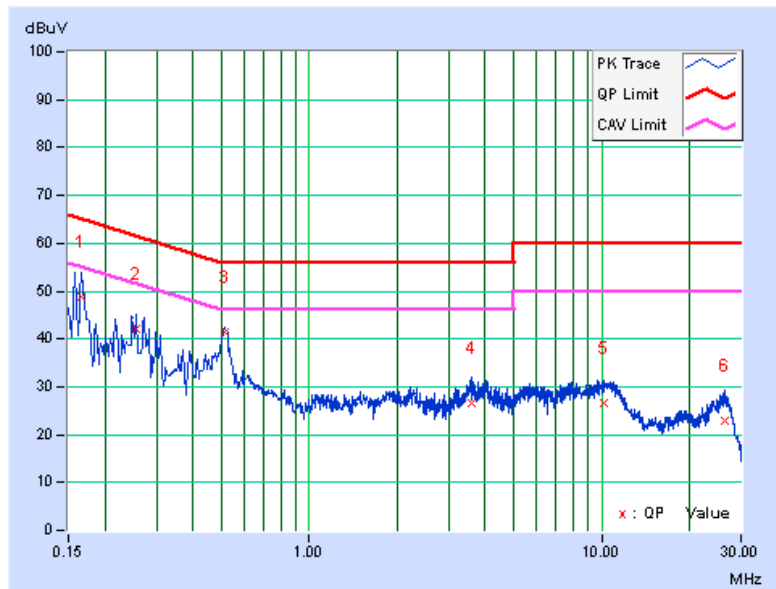



A D T

CHANNEL	CH 1 + CH 157	6dB BANDWIDTH	9kHz
PHASE	Line 2	TEST MODE	A

No	Freq.	Corr. Factor	Reading Value		Emission Level		Limit		Margin	
	[MHz]		[dB (uV)]		[dB (uV)]		[dB (uV)]		(dB)	
			Q.P.	AV.	Q.P.	AV.	Q.P.	AV.	Q.P.	AV.
1	0.15000	0.11	50.55	32.14	50.66	32.25	66.00	56.00	-15.34	-23.75
2	0.19255	0.11	44.99	28.30	45.10	28.41	63.93	53.93	-18.83	-25.52
3	0.51312	0.13	39.74	31.20	39.87	31.33	56.00	46.00	-16.13	-14.67
4	1.09622	0.14	30.69	21.01	30.83	21.15	56.00	46.00	-25.17	-24.85
5	3.48523	0.20	25.78	18.65	25.98	18.85	56.00	46.00	-30.02	-27.15
6	10.66790	0.39	28.82	21.66	29.21	22.05	60.00	50.00	-30.79	-27.95

REMARKS:

1. Q.P. and AV. are abbreviations of quasi-peak and average individually.
2. The emission levels of other frequencies were very low against the limit.
3. Margin value = Emission level - Limit value
4. Correction factor = Insertion loss + Cable loss
5. Emission Level = Correction Factor + Reading Value

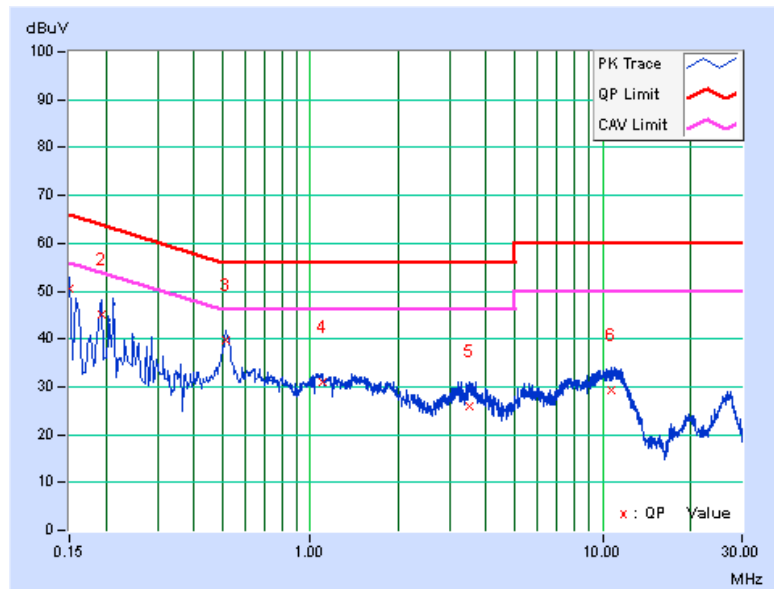

CHANNEL	CH 1 + CH 48	6dB BANDWIDTH	9kHz
PHASE	Line 1	TEST MODE	B

No	Freq.	Corr. Factor	Reading Value		Emission Level		Limit		Margin	
	[MHz]		[dB (uV)]		[dB (uV)]		[dB (uV)]		(dB)	
			Q.P.	AV.	Q.P.	AV.	Q.P.	AV.	Q.P.	AV.
1	0.23586	0.10	44.82	41.81	44.92	41.91	62.24	52.24	-17.32	-10.33
2	0.35332	0.12	42.40	39.68	42.52	39.80	58.88	48.88	-16.37	-9.09
3	0.46669	0.12	41.06	37.64	41.18	37.76	56.57	46.57	-15.39	-8.81
4	0.70209	0.13	39.03	35.61	39.16	35.74	56.00	46.00	-16.84	-10.26
5	1.87040	0.17	35.21	26.70	35.38	26.87	56.00	46.00	-20.62	-19.13
6	14.85942	0.69	40.24	38.72	40.93	39.41	60.00	50.00	-19.07	-10.59

REMARKS:

1. Q.P. and AV. are abbreviations of quasi-peak and average individually.
2. The emission levels of other frequencies were very low against the limit.
3. Margin value = Emission level - Limit value
4. Correction factor = Insertion loss + Cable loss
5. Emission Level = Correction Factor + Reading Value

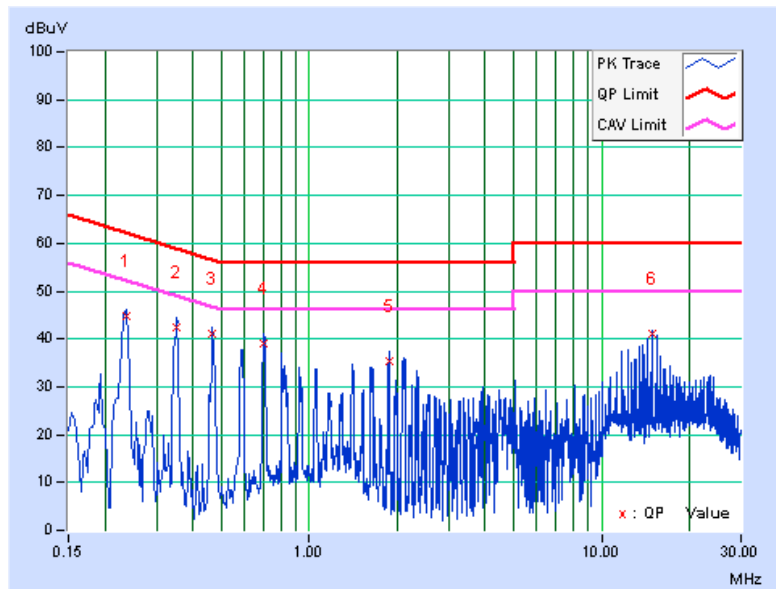

CHANNEL	CH 1 + CH 48	6dB BANDWIDTH	9kHz
PHASE	Line 2	TEST MODE	B

No	Freq.	Corr. Factor	Reading Value		Emission Level		Limit		Margin	
	[MHz]		[dB (uV)]		[dB (uV)]		[dB (uV)]		(dB)	
			Q.P.	AV.	Q.P.	AV.	Q.P.	AV.	Q.P.	AV.
1	0.23586	0.11	42.93	38.64	43.04	38.75	62.24	52.24	-19.20	-13.49
2	0.47039	0.13	40.95	38.59	41.08	38.72	56.51	46.51	-15.43	-7.79
3	0.70131	0.14	39.81	34.59	39.95	34.73	56.00	46.00	-16.05	-11.27
4	0.82643	0.14	39.48	31.98	39.62	32.12	56.00	46.00	-16.38	-13.88
5	1.88213	0.16	34.93	26.17	35.09	26.33	56.00	46.00	-20.91	-19.67
6	14.29638	0.47	40.83	39.27	41.30	39.74	60.00	50.00	-18.70	-10.26

REMARKS:

1. Q.P. and AV. are abbreviations of quasi-peak and average individually.
2. The emission levels of other frequencies were very low against the limit.
3. Margin value = Emission level - Limit value
4. Correction factor = Insertion loss + Cable loss
5. Emission Level = Correction Factor + Reading Value

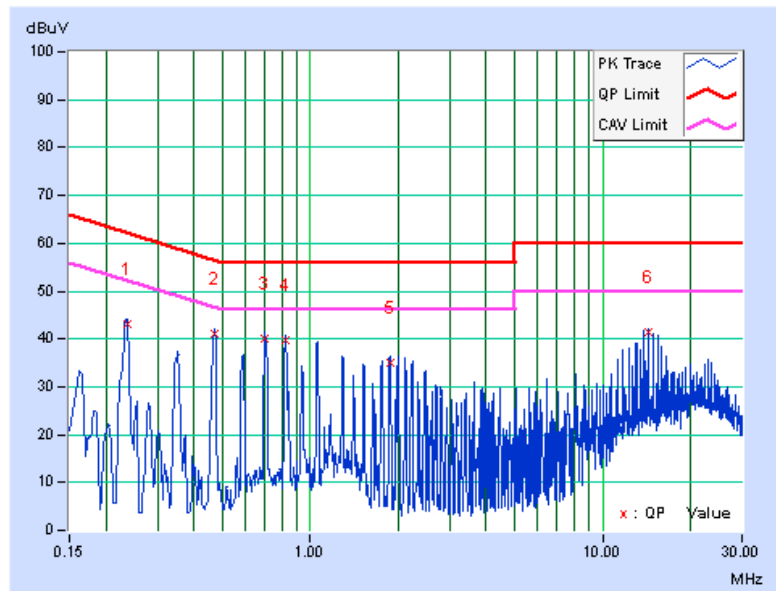

CHANNEL	CH 1 + CH 157	6dB BANDWIDTH	9kHz
PHASE	Line 1	TEST MODE	B

No	Freq.	Corr. Factor	Reading Value		Emission Level		Limit		Margin	
	[MHz]		[dB (uV)]		[dB (uV)]		[dB (uV)]		(dB)	
			Q.P.	AV.	Q.P.	AV.	Q.P.	AV.	Q.P.	AV.
1	0.23216	0.10	44.47	39.97	44.57	40.07	62.37	52.37	-17.80	-12.30
2	0.34926	0.11	41.53	38.22	41.64	38.33	58.98	48.98	-17.34	-10.65
3	0.47039	0.12	41.46	38.78	41.58	38.90	56.51	46.51	-14.92	-7.60
4	0.70131	0.13	39.02	33.64	39.15	33.77	56.00	46.00	-16.85	-12.23
5	12.33356	0.59	36.23	34.90	36.82	35.49	60.00	50.00	-23.18	-14.51
6	14.29638	0.67	41.13	39.72	41.80	40.39	60.00	50.00	-18.20	-9.61

REMARKS:

1. Q.P. and AV. are abbreviations of quasi-peak and average individually.
2. The emission levels of other frequencies were very low against the limit.
3. Margin value = Emission level - Limit value
4. Correction factor = Insertion loss + Cable loss
5. Emission Level = Correction Factor + Reading Value

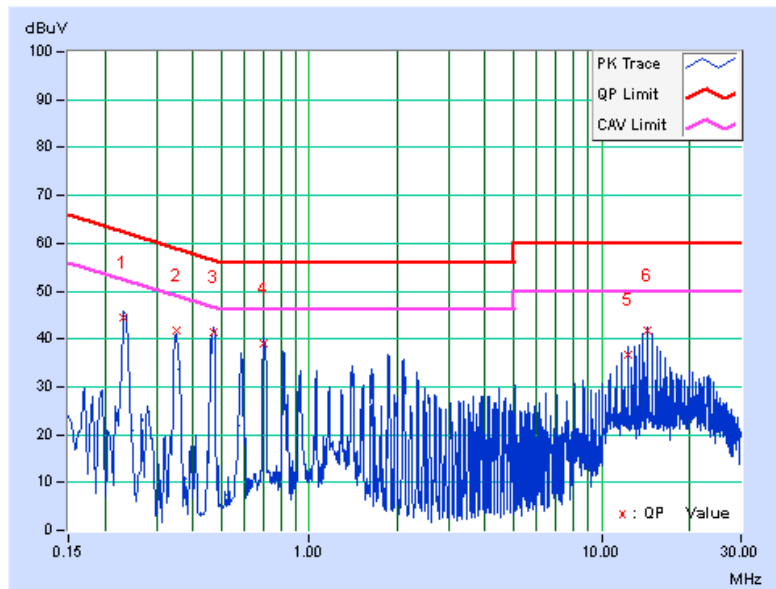

CHANNEL	CH 1 + CH 157	6dB BANDWIDTH	9kHz
PHASE	Line 2	TEST MODE	B

No	Freq.	Corr. Factor	Reading Value		Emission Level		Limit		Margin	
	[MHz]		[dB (uV)]		[dB (uV)]		[dB (uV)]		(dB)	
			Q.P.	AV.	Q.P.	AV.	Q.P.	AV.	Q.P.	AV.
1	0.23216	0.11	43.35	38.94	43.46	39.05	62.37	52.37	-18.91	-13.32
2	0.35332	0.13	37.53	29.47	37.66	29.60	58.88	48.88	-21.23	-19.29
3	0.46179	0.13	39.93	35.51	40.06	35.64	56.66	46.66	-16.60	-11.02
4	0.81372	0.14	38.17	34.01	38.31	34.15	56.00	46.00	-17.69	-11.85
5	2.09327	0.16	34.62	24.10	34.78	24.26	56.00	46.00	-21.22	-21.74
6	14.29638	0.47	41.76	40.33	42.23	40.80	60.00	50.00	-17.77	-9.20

REMARKS:

1. Q.P. and AV. are abbreviations of quasi-peak and average individually.
2. The emission levels of other frequencies were very low against the limit.
3. Margin value = Emission level - Limit value
4. Correction factor = Insertion loss + Cable loss
5. Emission Level = Correction Factor + Reading Value

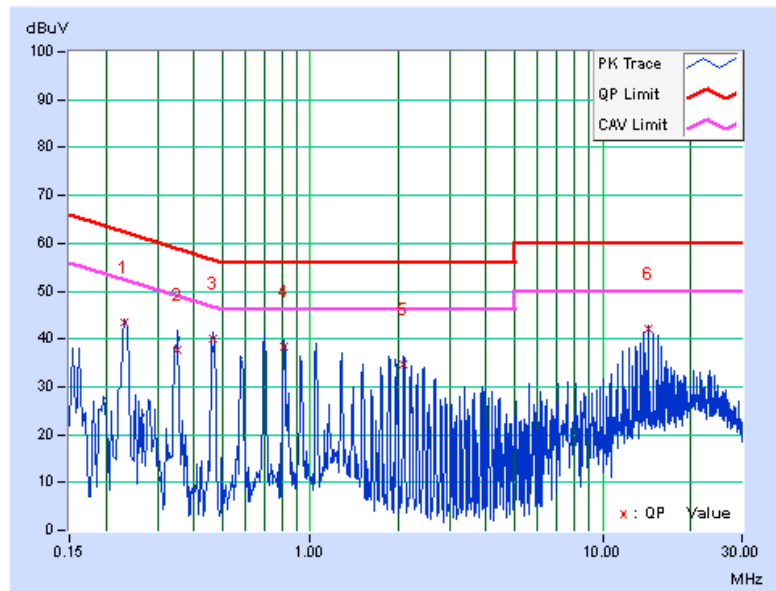



A D T

5. PHOTOGRAPHS OF THE TEST CONFIGURATION

Please refer to the attached file (Test Setup Photo).



A D T

6. INFORMATION ON THE TESTING LABORATORIES

We, Bureau Veritas Consumer Products Services (H.K.) Ltd., Taoyuan Branch, were founded in 1988 to provide our best service in EMC, Radio, Telecom and Safety consultation. Our laboratories are accredited and approved according to ISO/IEC 17025.

If you have any comments, please feel free to contact us at the following:

Linko EMC/RF Lab

Tel: 886-2-26052180

Fax: 886-2-26051924

Hsin Chu EMC/RF Lab

Tel: 886-3-5935343

Fax: 886-3-5935342

Hwa Ya EMC/RF/Safety/Telecom Lab

Tel: 886-3-3183232

Fax: 886-3-3270892

Email: service.adt@tw.bureauveritas.com

Web Site: www.bureauveritas-adt.com

The address and road map of all our labs can be found in our web site also.



A D T

7. APPENDIX A - MODIFICATIONS RECORDERS FOR ENGINEERING CHANGES TO THE EUT BY THE LAB

No modifications were made to the EUT by the lab during the test.

---END---