

Divoom®

PIXOO-MAX

INDOOR & IN-CAR PIXEL ART DISPLAY

This is Pixoo-max, your new pixel art display board from Divoom.

With a 32x32 pixel size display, Pixoo-max unlocks the world of pixel art. You can display a thumb up to the following car, or your favorite pixel art design.

What's included?

Pixoo-max

Pixoo-max stand

User manual

USB charging cable

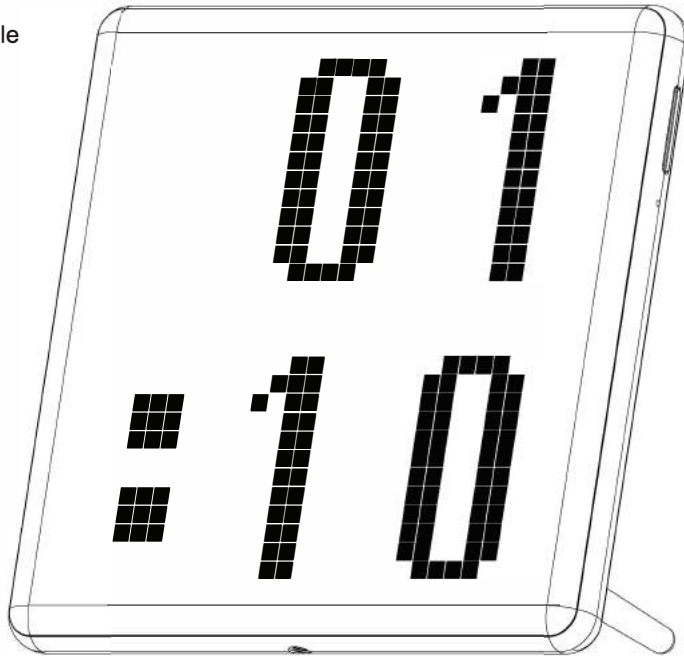

Thank you for purchasing a Divoom product! Please read this manual carefully. Visit www.divoom.com to learn more about our other products! Due to the nature of the technology product, the instructions on this manual are subject to change without prior notice.

If you have any questions, please feel free to contact the Divoom customer support.

■ Product details

- 1.HOLD: Power ON/OFF
PRESS:Show battery status
- 2.HOLD: Change lighting effects
PRESS:Change channel
- 3.Microphone Ports
- 4.Stand port
- 5.USB-C charging port
- 6.Charging indicator light
- 7.Car mount screw holes
(for car mount accessory only)

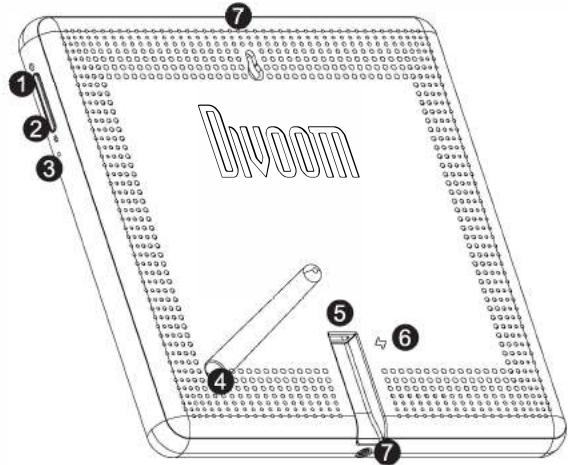

■ How to connect in Bluetooth

The Divoom Smart application is available in both iOS and Android APP stores. You can search for 'Divoom' or scan this QR code.



Download the Divoom
from the App Store
and Google Play™

- 1.In the Phone's Settings, please turn ON Bluetooth
- 2.In the Divoom mobile application, please connect with the 'Pixoo-max'.
 - If you cannot find 'Pixoo-max', please try: a) restart the Bluetooth function, b) clear Bluetooth paired device history, c) enable phone's GPS location service.

■ How to enable voice control?

1. Connect your Pixoo-max in the Divoom APP
2. Go to Discover > Voice control
3. Tap the command to modify the keyword
4. Tap on the black square to select the corresponding image/action.
5. When completed, just say “Hey, Siri. xxx” (xxx = keyword).



“Hey, Siri. Turn Left”

- The voice control function is currently only available for the iOS device. The android version is still under development.
- In order for this function to work, the Pixoo-max must be connected in the Divoom APP.

■ How to charge?

1. Insert the USB cable into the USB port on the rear panel.
2. The indicator will light up during charge, and turn off when 100% charged.

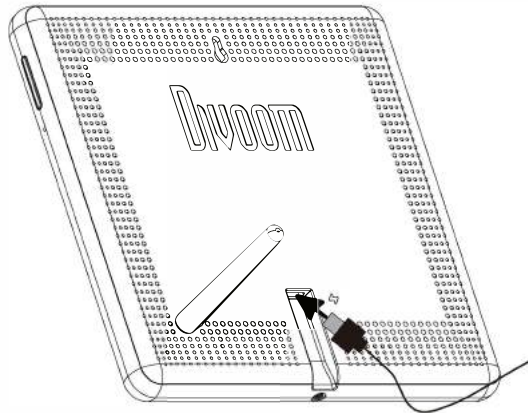

■ What is car mode? And how to enable/disable it?

Car mode is a default enabled function for the **Pixoo-max**. When enabled, the **Pixoo-max** will automatically power ON when the car's ignition is ON and connected. When the car is shut off, the **Pixoo-max** will then power OFF itself. When the car mode is disabled, the **Pixoo-max** will require manual power ON and OFF.

To enable or disable this function, please use the Divoom APP:

1. Connect your **Pixoo-max** in the Divoom APP
2. Go to Settings>LED Settings, and toggle ON/OFF the Car Mode.

■ In some markets, the car mount accessory may sold separately. In such case, we may recommend to disable the car mode for normal indoor use.

■ WARNING:

IN CAR USE MAY NOT BE LEGAL IN CERTAIN STATE/COUNTRY. ALWAYS CHECK YOUR LOCAL TRAFFIC LAWS.



■ Product specification

Dimension (mm):172.8L x 172.8W x 19H

Weight:495g

Playback time:12HRS

Battery capacity:5000mAh

Battery voltage:3.7V

Battery charge time:5-6hrs

Charge:via USB cable, 5V-2A

Wireless range:up to 10 meters/33 feet

Bluetooth compliant:v5.0

■ WARRANTY INFORMATION:

1.If you believe your product is defective within the warranty period, please bring the product back to where the product was initially purchased. Alternatively, or within any other questions or concerns, please call customer support at +0755 86290767, or contact us via email at info@divoom.com.

2.If within 12 (24 if required by local law) months of purchase this device or any part thereof is proven to be defective by reason of faulty workmanship or defects in materials, we will at our option repair or replace the same free of charge of labor or materials on condition that similar to the product current condition.

3.The sales invoice or receipt with the date and source of purchase must be presented together with the defective unit. We cannot validate the product warranty information without an invoice.

4.The warrant does not cover product failures which have been caused by use of accessories other peripheral devices which are not Divoom branded original accessories intended for use with the product.

5.The warranty does not cover product failures caused by: modification, repaired, and disassembled by any person who is not authorized by the manufacture.

6.The warranty is non transferable. Any defective unit or part shall become property of the manufacture.

7.Warranty does not cover any damage caused by misuse, drop, hit or negligent.

8.Customer is responsible for the return shipping charges.

This product is in compliance with Directive 2011/65/EU of the European Parliament and of the Council of 8 June 2011 on the restriction of the use of certain hazardous substances in electrical and electronic equipment.

■ Please read the following instructions carefull:

■ Please follow our product installation and operation instructions.

■ Always place the speaker on a smooth and stable surface.

■ Please place the speaker on an open area for the best sound quality. Do not block the surroundings of the speaker.

■ Do not push any objects into speaker vents or slots. Do not apply any great force on the speaker.

■ Please keep the speaker in a room temperature environment. Do not place the speaker near any heat sources (such as radiators, heat registers, stoves, fire place, or direct sunlight). Do not place the speaker near any open flame source.

■ Do not attempt to service the speaker by yourself. Always refer to the instructions by qualified service personnel.

■ To avoid the risk of electrical hazard, do not expose this speaker to wet surface.

■ DECLARATION OF CONFORMITY:

CE This device meets the essential requirements of the following Directive 2014/53/EU of the European parliament of the council of 16 April 2014.

The waste container symbol with the X through it on the device indicates that the device must be disposed of separately from normal domestic waste at an appropriate waste disposal facility at the end of its useful service life

■ Limited Warranty

1. If within 12 months of purchase this device or any part thereof is proven to be defective by reason of faulty workmanship or defects in materials, we will at our option repair or replace the same free of charge of labor or materials on condition that.

2. The original invoice or sales receipt with the date of purchase, or stamp from the dealer is presented together with the defective unit.

3. The warranty does not cover product failures which have been caused by use of accessories other peripheral devices which are not DIVOOM branded original accessories intended for use with the product.

4. The warranty does not cover product failures caused by: Modification, repaired, and disassembled by any person who is not authorized by the manufacturer. Any defective unit or part shall become property of the manufacturer. The warranty does not cover any damage caused by misuse, drop, hit or neglect.

FCC STATEMENT :

This device complies with Part 15 of the FCC Rules. Operation is subject to the following two conditions

(1) This device may not cause harmful interference, and

(2) This device must accept any interference received, including interference that may cause undesired operation.

Warning: Changes or modifications not expressly approved by the party responsible for compliance could void the user's authority to operate the equipment.

NOTE: This equipment has been tested and found to comply with the limits for a Class B digital device, pursuant to Part 15 of the FCC Rules. These limits are designed to provide reasonable protection against harmful interference in a residential installation. This equipment generates uses and can radiate radio frequency energy and, if not installed and used in accordance with the instructions, may cause harmful interference to radio communications. However, there is no guarantee that interference will not occur in a particular installation. If this equipment does cause harmful interference to radio or television reception, which can be determined by turning the equipment off and on, the user is encouraged to try to correct the interference by one or more of the following measures:

- Reorient or relocate the receiving antenna.

- Increase the separation between the equipment and receiver.

- Connect the equipment into an outlet on a circuit different from that to which the receiver is connected.

- Consult the dealer or an experienced radio/TV technician for help.

FCC Radiation Exposure Statement:

This equipment complies with FCC radiation exposure limits set forth for an uncontrolled environment. This equipment should be installed and operated with minimum distance 20cm between the radiator & your body.

■ WARRANTY INFORMATION

This product is covered by a limited warranty from Divoom. For complete warranty details, visit the website www.Divoom.com

PRODUCT WARRANTY CARD

Product name: _____
Serial number: _____
purchasing store: _____
Purchasing date: _____
Owner name: _____
Contact Email: _____
owner address: _____

■ Divoom official website:

<http://www.divoom.com/>

■ Divoom warranty information:

<http://www.divoom.com/article/detail/id/60.html>

■ Divoom product FAQ:

<http://www.divoom.com/article/detail/id/59.html>

■ Divoom support Email:

info@divoom.com

■ Divoom support contact number:

0755-29494509

Divoom repair & return address:

Shenzhen Divoom Technology Limited Corporation 1st Floor, 5th Building, XinLianHe Industrial
Complex Shajing Town, Baoan District Shenzhen City, Guangdong Province
518000 The people's republic of China

www.divoom.com