

Amazboost

A1 Cell Phone Signal Booster Manual



Manufactured and Warranted by
Amazboost Technology Inc.
www.amazboost.com

customer service number:

Office (435) 319-6858

Toll Free (877) 579-7878

Support@Signalbooster.zendesk.com

Operational Diagram
(How It Works)
Package Contents
Page 2

Basic Signal Level Knowledge
Page 3

Preparation
Page 4

Installation Step By Step
Page 5 - 12

Trouble Shooting
Page 13 - 14

Technical Specification
Warranty Information
Page 15

Safety Guidelines
Page 16

Working Diagram (How It Works)

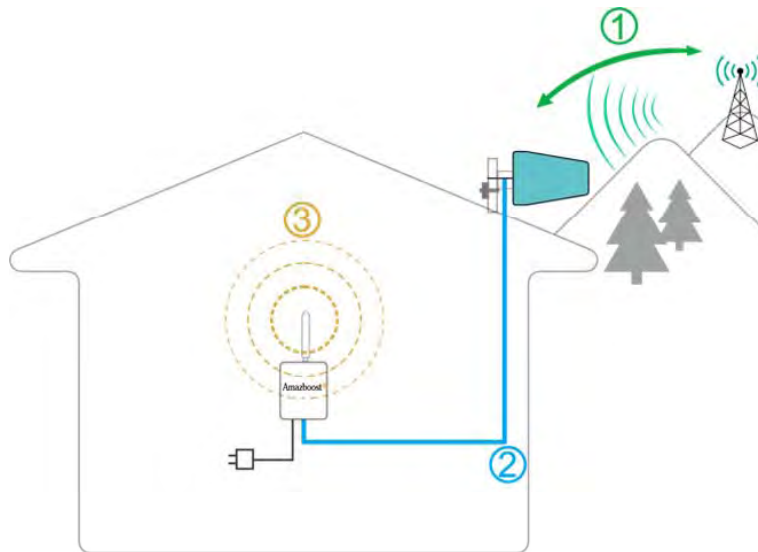

1. The outdoor antenna catches the signal from the tower.
2. Sends outside signal to the booster through a coax cable.
3. The booster amplifies the signal then rebroadcasts the signal indoors to all mobile devices within range.
4. The system also works in reverse; amplifying outgoing signal back to the tower.



The coverage area and the **strength** of the boosted signal are directly related to two key factors:

1. **Signal strength received** by the outdoor unit. So, setting up the outside unit where the signal is the strongest will provide the best results.
2. Distance of **separation** between the outdoor unit and the indoor unit.

Package Contents

The kit includes the following items:

1. Outdoor Antenna (with mounting kits);
2. Booster(with indoor antenna);
3. Power supply;
4. 60 ft of RG6 cable, for connecting the outdoor antenna and booster;



Outdoor Antenna



Booster & Indoor Antenna



Power supply



RG6 cable

Signal transmission loss and power level

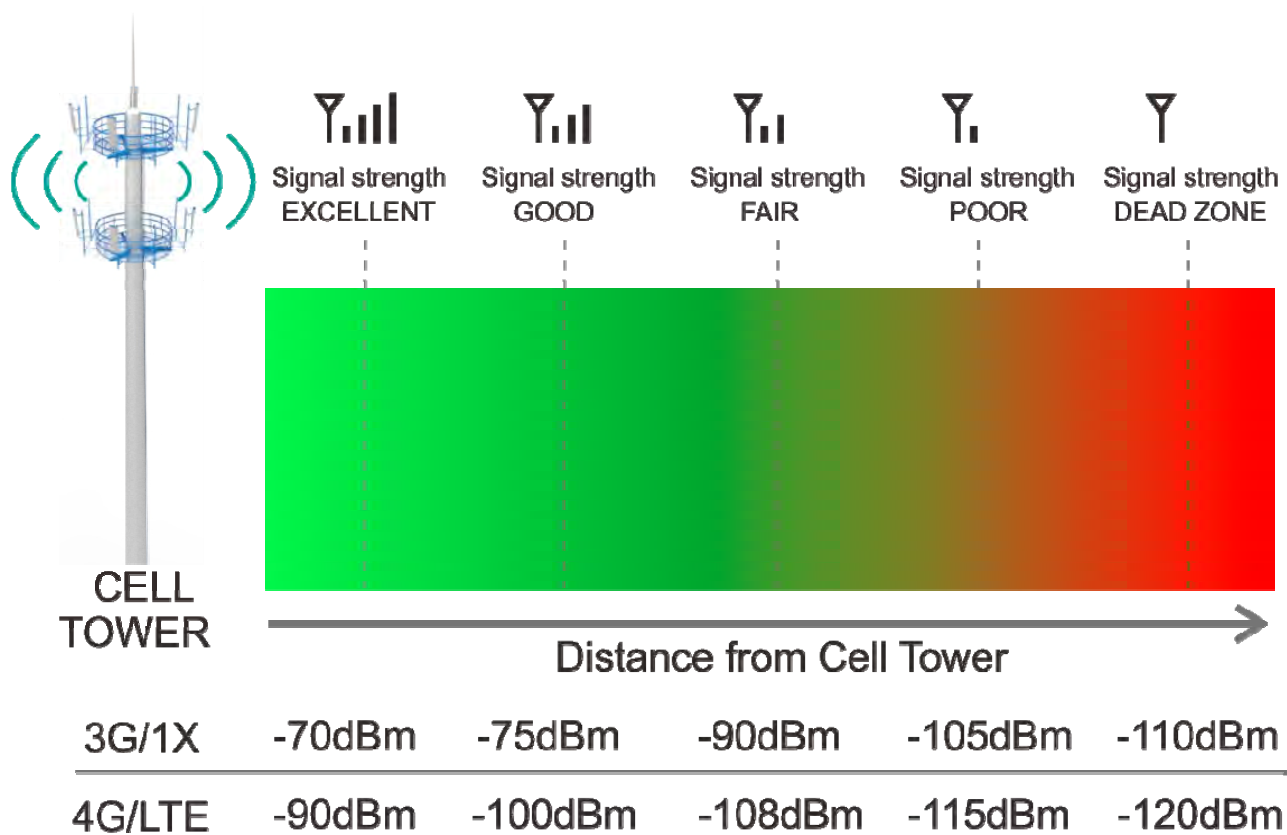

Coverage area ability

Note: FCC regulations limit the amplification of all cell phone boosters in order to prevent damage to the telecommunications infrastructure. Therefore, the maximum coverage area of a booster depends on the original power level of the signal captured by the outdoor unit.

⚠ Notice: Not recommended when outdoor signal strength is less than -110dbm(3G/1x) or -120dBm(4G/LTE). The resulting coverage area of the boosted signal will be prohibitively small.

Power level at the outdoor antenna location	Coverage Area (sq. ft.)
Strong (5 bars on the cellphone)	2,500
Medium (3~4 bars on the cellphone)	1,300
Weak (1~2 bars on the cellphone)	400

Preparation

Find a cell tower nearby!

There are a variety of resources available online, here are some third party websites and app recommended. Use these to locate your nearest cell tower, either by street address or GPS coordinates.

For U.S. websites:

www.antennasearch.com/

www.cellmapper.net/

www.cellreception.com/towers

For Canada website:

www.cellmapper.net/

APP: Tower Locator (iPhone or Android)



Find The dBm Reading On Your Phone

Having an accurate measurement of signal strength in decibels (dBm) is crucial when installing your system. Decibels accurately measure the signal strength you are receiving. Test both 3G and 4G signal for best results by turning the LTE off in the carrier settings of your device.

iPhone: need to download third part APP;

Android: Settings > About Phone > Status or Network > Signal Strength or Network Type and Strength (exact options/wording depends on phone model).

Note: Turn off your cell phone's WiFi to ensure you are checking the cellular connection. The dBm reading will be refreshed every 30-60 seconds. Want faster results? Once you have a reading, turn on airplane mode. Wait 15 seconds. Turn off airplane mode. The signal strength reading is refreshed.

You Will Need (make sure the following things and tools are prepared and ready for your installation.)

- 2~3 hours
- 2 people (a person to help with antenna calibration)
- Drill (if routing cable through wall)
- Recommended: Power Strip with surge protection

Test Installation

We **STRONGLY** recommend doing a test installation before finalizing the installation. Doing a test installation of your cell phone booster ensures that you will get the optimal performance from your system.

Step1: Measure the Signal Strength Inside your Home

- Test your current signal strength in multiple locations throughout the home
- Record the current signal strength in the table provided for reference



No	Location	Record(dBm)
1		
2		
3		
4		
5		

Step2: Select the Location for the Inside Antenna

- Should have access to a power outlet
- The indoor unit contains an omni-directional antenna. Choosing a central location in your home will help to maximize your coverage area.



Step3: Select the Location for the Outside Unit

1. This is the most critical step and will determine the overall performance of the booster system.
2. Using the same method described in Step 1, walk around the outside of your home and test the signal strength. Determine where you have the strongest signal (the dBm reading is closest to zero).
3. Generally, the strongest signal will be located on the side of your home facing the nearest cell tower. Keep in mind, the signal strength at ground level may be different from the signal strength at or above the roofline due to obstructions (trees, other buildings, etc.) that block the incoming signal. In most situations, the strongest signal is found about 15 feet above the ground on the side of your home facing the nearest cell tower.

Caution

- The height of the outside antenna should never exceed the highest point of your home. This is a precaution against damage and safety concerns caused by lightning strikes to the outside unit.
- In order to achieve the best performance, try to maximize the distance between the inside and outside antenna.
- Ensure that the outside antenna is pointed away from where you plan to install the inside antenna. Self-oscillation may occur if the outside antenna is pointed over the location of the inside antenna.

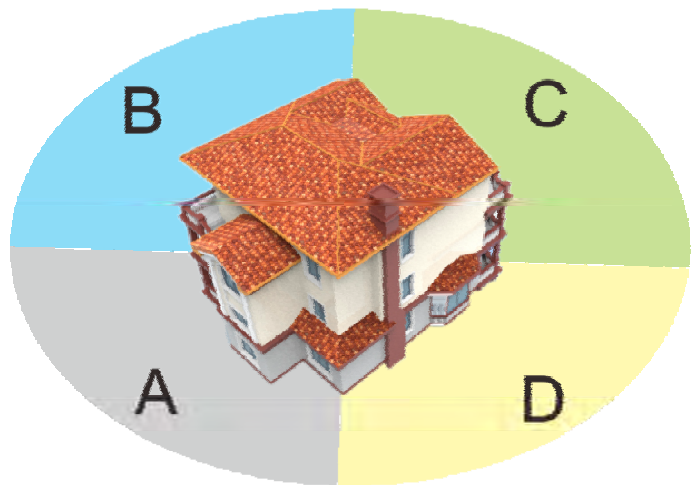

Test



Record

No	Location	Record(dBm)
1		
2		
3		
4		
5		

Step 4: Temporarily Mount the Outside Antenna

Use one of the three options to mount the outside antenna on your roof on the side of the house with the strongest signal



Caution

In order to achieve the best signal coverage effect, there is a certain distance requirement between the indoor and outdoor units. Make sure the inside and outside units are facing away from each other.

Minimum Required Separation Distance Between Indoor and Outdoor Antenna:

20 ft (6 meters) horizontal distance

13 ft (4 meters) vertical distance (As far as possible)

Make sure to meet the Minimum Separation Requirements while at the same time mounting the outside unit in the location with the strongest signal.

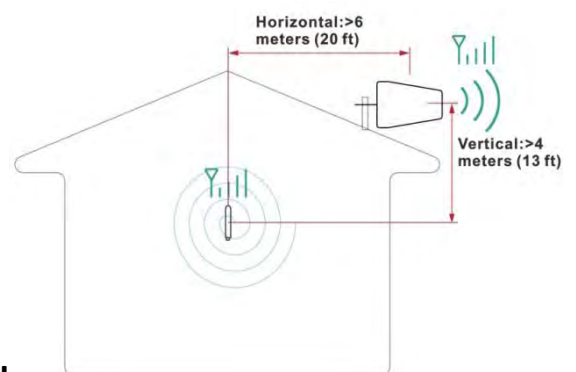

Step5: Connect the System

1. Connect the outside antenna to the 30 feet RG6 cable, fix the connector(In order to avoid internal damage of the antenna connector due to gravity or pulling the cable)

Secure the cable near the antenna to prevent cable damage caused by wind shaking



2. Connect the "OUTSIDE" port on booster and the outside antenna together by using the coax cable.



3. Connect the inside antenna to the "INSIDE" port on the booster.



4. Plug in the power adaptor and connect it to the nearest power outlet (surge protector recommended).



Step6: Evaluate the Effects

- Now that the booster is up-and-running, re-test the signal strength inside your home at the same locations from Step 1. If the number is higher (dBm reading is closer to zero) than the original reading, your booster is working.
- If your signal is not stronger, check the LED lights on the booster and refer to the “Quick Troubleshooting” section at the end of the manual.



No	Location	Record(dBm)
1		
2		
3		
4		
5		

Decibel Gain vs. Power Amplification/Distance/Coverage area

Decibel Gain	Power Amplification (times)	Distance Enhance (times)	Coverage Enhance (times)
6	4	2	4
10	8	3	9
20	100	8	64
30	1000	32	900

Note: Decibel Gain and Power Amplification may vary depending on the specifics of your situation. Different building materials and other obstructions in your home will result in different outcomes.

Step7: Finalizing Outdoor Antenna Installation

Once you have tested the performance of the signal booster and made all necessary adjustments, it's time to finalize the installation.

Outdoor Antenna Installation

Make sure that the outside unit is mounted at least 3 feet away from any windows.

Option A : Outside Roof Pole Mount (Best Choice) Use an existing pole to mount the outdoor unit in the optimal signal location. Use the picture for reference.

Option B : Mounting on Side of Wall (Second Choice)

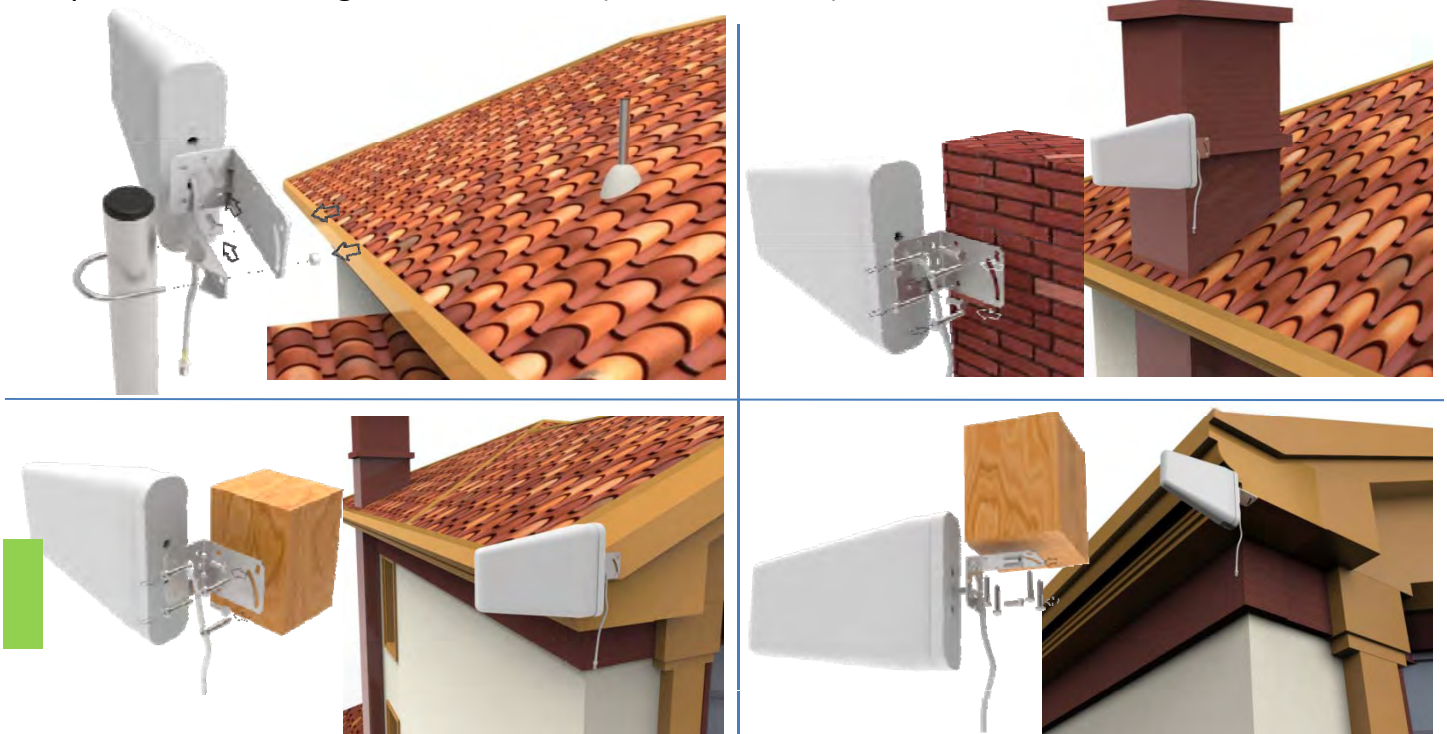

Caution

In particular, cables for outdoor antenna locations must be fixed. Otherwise, the internal wires of the cable will be pulled off after the wind has been shaken for a long time. The amplifier will not receive the signal and the system will fail completely.

⚠ As shown in the figure, it is best to have the cable around a single turn shape and then fix it.

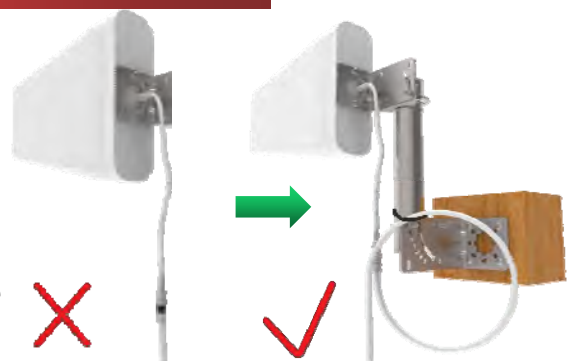

Long-term rain or moisture erosion can damage the electrical characteristics of outdoor antenna connectors. Make sure connectors are well screwed in and seal the connectors with glued tape.

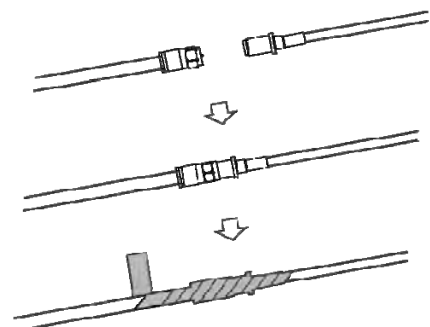

Step8: Finalizing Indoor Installation

1. Choose right position for the indoor antenna
 - 20 cm away from any other metallic objects
 - 50 cm away from any windows
2. Mount the booster
 - Choose a ventilated and dry place
 - Keep away from heat
 - Don't cover booster

 Booster will about 30 degrees Fahrenheit higher than the ambient temperature, which is a normal phenomenon.



Step9: Finalizing and Securing Cable Route

- Find the best route for the cable. Follow the lines of your home to hide the cable in eaves or between the soffit and the exterior wall.
- If needed, cable clips can be purchased at most hardware stores.



- Whether the cable is properly secured is very important for the entire system. In most cases, the customer found that the booster did not work after working for a period of time because the cable was not installed securely.
- Carefully arrange the cable along the outside of the building and ensure that there are no folds or kinks. Fix the cable at each corner



Caution

Seal and Fix the Connector

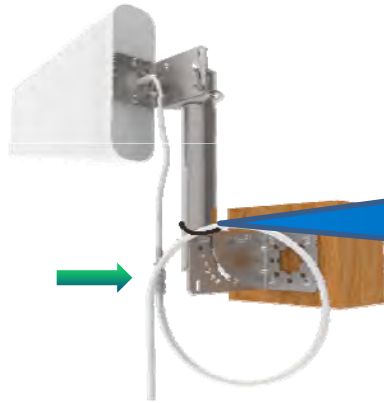
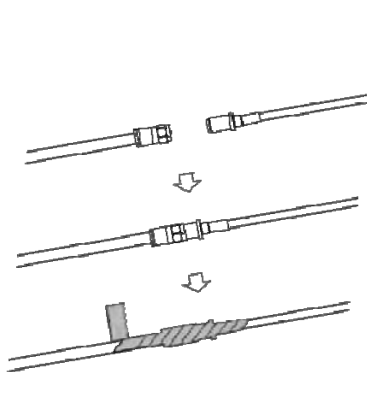

Secure the cable near the antenna to prevent cable damage caused by wind shaking

Properly Handle Excess Cables

If the coiled cable is too close to the antenna or booster, the system will be unstable. Make sure these coiled cables are more than 6 feet (2 meters) from the antenna or booster



Make sure these excess coiled cables are more than 6 feet (2 meters) from the antenna or booster can make your system work more stable.

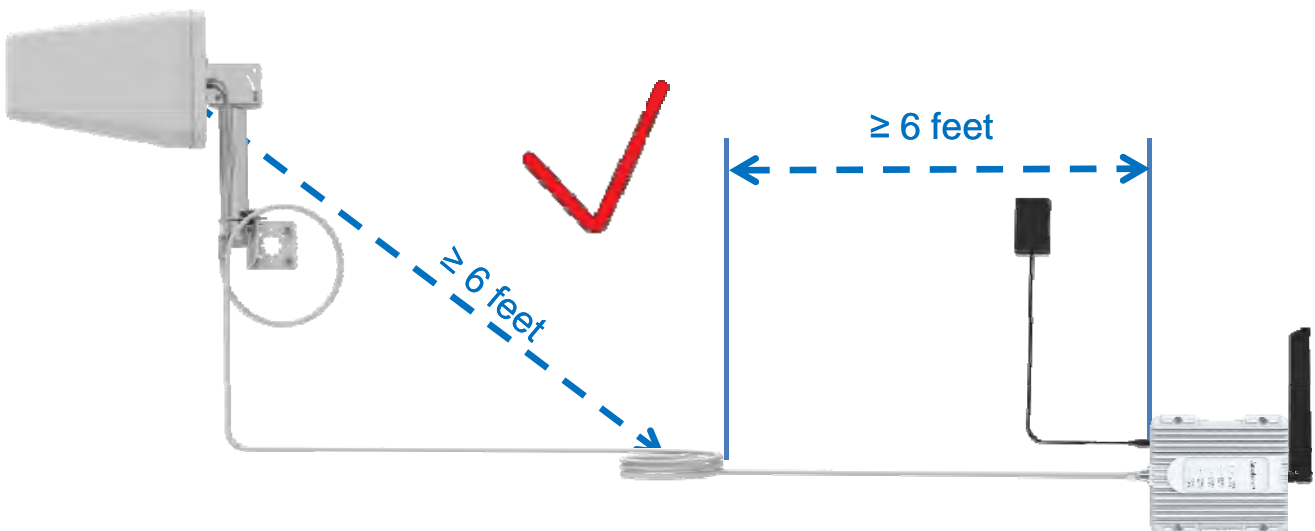

Quick Trouble shooting

Correct functioning:

- Power Light should be solid green
- The lights on the front panel indicate the condition of the booster. Every time the booster is powered on, all of the lights will be green in color for several seconds then off. This means the booster has passed the self check and is in good condition..



Power Light



Panel State Light

Incorrect Functioning: *(Please see the Troubleshooting Guide for further details)*

- If any of the lights on the front panel are flashing in green then off/continue flashing/solid green, it means that self oscillation is occurring. You must switch off the booster and check the outside and inside antennas immediately. Make sure you have followed the recommended installation process and check each step carefully. Refer to Self Oscillation section for more details of minimum required separation distance, antennas installation. If you can not fix the problem please contact the technical support or the reseller.

Amazboost Technical Support: Support@Signalbooster.zendesk.com

Trouble Shooting: No Signal Improvement

Step 1. Check power. Ensure the indoor unit is plugged in and the LED Power Light is green.



Trouble Shooting: No Signal Improvement

Step 2. Check cable connections. Ensure the indoor and outdoor units are securely connected to the coax cable.

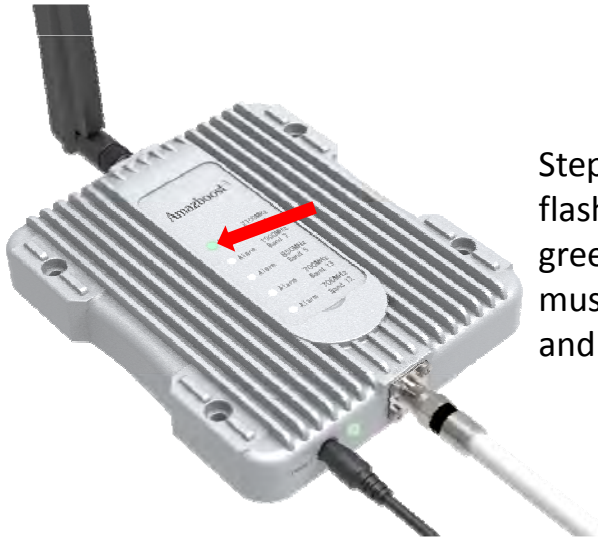

Step 3. If any of the lights on the front panel are flashing in green then off/continue flashing/solid green, it means that self oscillation is occurring. You must switch off the booster and check the outside and inside antennas immediately.

Step 4. Double check the location of outdoor and indoor units. Make sure that the Minimum Separation Requirements have been met. Make sure that the outside antenna is not pointed towards the inside antenna.

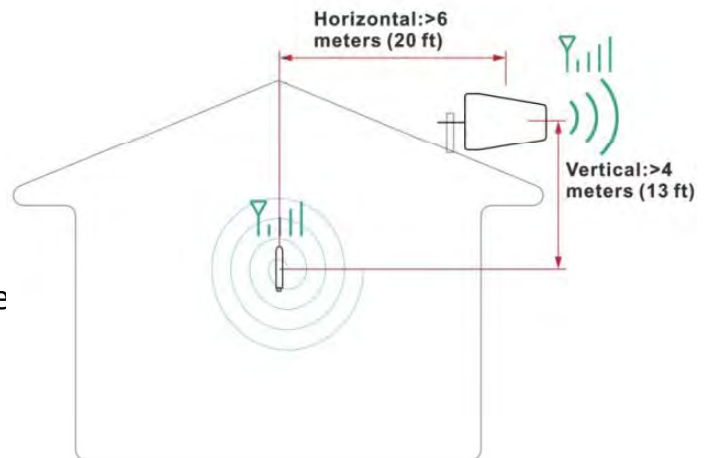

Minimum Required Separation Distance Between Indoor and Outdoor Unit:
Horizontal Distance = 20 feet (6 meters)
Vertical Distance = 13 feet (4 meters) (As far as possible)



Step 5. Check incoming signal level at outdoor unit position. Usage of a booster is not recommended when the outdoor signal is less than -110dbm(3G/1x) or -120dBm(4G/LTE).

If you have any questions or concerns when installing or operating your cell phone booster, please email us: Support@Signalbooster.zendesk.com
Or call our customer service: 877-579-7878

Technical Specification

Frequency (MHz)		LTE (band 12)	LTE (band 13)	Cellular (band5)	PCS (band 25/2)	AWS (band 4)
		Uplink	698-716	776-787	824-849	1850-1915
	Downlink	728-746	746-757	869-894	1930-1995	2110-2155
Gain	Uplink	55±2	55±2	55±2	60±2	60±2
	Downlink	60±2	60±2	60±2	65±2	65±2
Output power	26±2dBm(Uplink)/0±2dBm(Downlink)					
Noise figure	<5dB					
In-band Flatness	<8dB					
Weight	0.7Kg					
EIRP	1W					
Impedance	50 ohm					
Operating temperature	-5° ~60°					
Current	≦ 1.5A(6V DC)					
Dimension(mm)	155*125*25					

WARRANTY



The Outdoor Unit and Indoor Unit are covered under a three-year product warranty for failures or defects that result from craftsmanship and/or materials. Dated proof of purchase should be retained for use in warranty cases. Contact the retailer/reseller directly with any warranty issues, or alternatively contact the manufacturer in cases where the reseller is no longer available to handle warranty claims. In cases where the reseller is unavailable, the product may be returned to the manufacturer at the consumer's expense, with a dated proof of purchase and a return authorization letter which can be attained by contacting Amazboost.

This warranty does not apply to any signal booster components determined by Amazboost to have been subjected to misuse, abuse, neglect, tampering, or mishandling that result in damages to the physical or electronic properties of the product. Refurbished products that have been recertified to conform to product specifications may be used for product replacements.

DISCLAIMER: The information provided by Amazboost is believed to be complete and accurate, to the best of our knowledge. However, no responsibility is assumed by Amazboost for any business or personal losses arising from the use of the information herein contained, or for any infringements of patents or other rights of third parties that may result from its use.

**If you have any questions or concerns when installing or operating your cell phone booster, please email us: Support@Signalbooster.zendesk.com
Or call our customer service: 877-579-7878**

Safety Guidelines

To uphold network protection standards and ensure compliance, all active cellular devices must maintain a separation distance of at least six feet between the inside unit antenna and outside unit antenna and at least four feet of separation distance from the inside unit. Use only the power supply provided in this package. Use of a non-Amazboost product or accessory may result in damage to the equipment or components of the equipment. The inside unit is designed for use in an indoor, temperature-controlled environment (less than 100 degrees Fahrenheit). It is not intended for use in attics or similar locations where temperatures may be in excess of that range.

RF Safety Warning: Any antenna used with this device must be located at least 8 inches from all persons.

This is a **CONSUMER** device.

BEFORE USE, you **MUST REGISTER THIS DEVICE** with your wireless provider and have your provider's consent. Most wireless providers consent to the use of signal boosters. Some providers may not consent to the use of this device on their network. If you are unsure, contact your provider.

In Canada, **BEFORE USE** you must meet all requirements set out in ISED CPC-2-1-05. You **MUST** operate this device with approved antennas and cables as specified by the manufacturer. Antennas **MUST** be installed at least 20 cm (8 inches) from (i.e., **MUST NOT** be installed within 20 cm of) any person.

You **MUST** cease operating this device immediately if requested by the FCC (or ISED in Canada) or licensed wireless service provider.

WARNING. E911 location information may not be provided or may be inaccurate for calls served by using this device.

FOR MORE INFORMATION ON REGISTERING YOUR SIGNAL BOOSTER WITH YOUR WIRELESS PROVIDER, PLEASE SEE BELOW:

Sprint: http://www.sprint.com/legal/fcc_boosters.html

T-Mobile/MetroPCS: <https://support.t-mobile.com/docs/DOC-9827>

Verizon Wireless: <http://www.verizonwireless.com/wcms/consumer/register-signal-booster.html>

AT&T: <https://securec45.securewebsession.com/attsignalbooster.com/>

U.S. Cellular: <http://www.uscellular.com/uscellular/support/fcc-booster-registration.jsp>

If you have any questions or concerns when installing or operating your cell phone booster, please email us at

Support@Signalbooster.zendesk.com

Or call our customer service number

Office **(435) 319-6858**

Toll Free **(877) 579-7878**

Description of network protection features:

This booster including safeguards to protect the cellular network from interference. Each Signal Booster is individually tested and factory set to ensure FCC compliance.

1. The Signal Booster cannot be adjusted without factory reprogramming or disabling the hardware.
2. The Signal Booster will amplify, but **ONLY** incoming and outgoing signals in order to increase coverage of authorized frequency bands.
3. If the Signal Booster is not in use for five minutes, it will reduce gain until a signal is detected.
4. If a detected signal is too high in a frequency band, or if the Signal Booster detects an oscillation, the Signal Booster will automatically turn the power off on that band.
5. For a detected oscillation the Signal Booster will automatically resume normal operation after a minimum of 1 minute. After 5 times consecutive such automatic restarts, if the detected oscillation still remains, any problematic bands are permanently shut off until the Signal Booster has been manually restarted by reconnecting power supply to the Signal Booster.
6. Noise power, gain, and linearity are maintained by the Signal Booster's microprocessor.

This is a CONSUMER device

BEFORE USE, you MUST REGISTER THIS DEVICE with your wireless provider and have your provider's consent. Most wireless provider consent to the use of signal boosters. Some provider may not consent to the use of this device on their network. If you are unsure, contact your provider.

You MUST operate this device with approved antenna and cables as specified by the manufacturer. Antennas MUST be installed at least 20cm (8inches) from any person.

You MUST cease operating this device immediately if requested by the FCC or a licensed wireless service provider.

WARNING: E911 location information may not be provided or may be inaccurate for calls served by using this device.

This device may be operated ONLY in a fixed location for in-building use.

This device complies with Part 15 of FCC Rules. Operation is subject to the following two conditions: (1) this device may not cause harmful interference, and (2) this device must accept any interference received, including interference that may cause undesired operation.

Contact information for providers

A subscriber must have the consent of a wireless provider to operate a consumer signal booster. Please register your booster with your wireless service provider, refer to contact information for providers:

Sprint:

signalbooster@sprint.com

T-Mobile:

www.T-Mobile.com/BoosterRegistration

<https://support.t-mobile.com/docs/DOC-9827>

Verizon:

<http://www.verizonwireless.com/wcms/consumer/register-signal-booster.html>

AT&T:

<https://securec45.securewebsession.com/attsignalbooster.com/>

U.S. Cellular:

<http://www.uscellular.com/uscellular/support/fcc-booster-registration.jsp>

Metro PCS

<https://www.metropcs.com/support/signal-booster>

FCC Radiation Exposure Statement:

This equipment complies with FCC radiation exposure limits set forth for an uncontrolled environment.

This transmitter must not be co-located or operating in conjunction with any other antenna or transmitter.

This equipment should be installed and operated with minimum distance 20cm between the radiator & your body.

Any Changes expressly or modifications not approved by the party responsible for compliance could void the user's authority to operate the equipment.

Safety Guidelines

To uphold network protection standards and ensure compliance, all active cellular devices must maintain a separation distance of at least six feet between the inside unit antenna and outside unit antenna and at least four feet of separation distance from the inside unit. Use only the power supply provided in this package. Use of a non-SolidRF product or accessory may result in damage to the equipment or components of the equipment. The inside unit is designed for use in an indoor, temperature-controlled environment (less than 100 degrees Fahrenheit). It is not intended for use in attics or similar locations where temperatures may be in excess of that range.

RF Safety Warning: Any antenna used with this device must be located at least 8 inches from all persons.

This is a CONSUMER device

BEFORE USE, you **MUST REGISTER THIS DEVICE** with your wireless provider and have your provider's consent. Most wireless provider consent to the use of signal boosters. Some providers may not consent to the use of this device on their network. If you are unsure, contact your provider.

In Canada, **BEFORE USE** You must meet all requirements set out in ISED CPC-2-1-05. You **MUST** operate this device with approved antenna and cables as specified by the manufacturer. Antennas **MUST** be installed at least 20cm (8inches) from (i.e., **MUST NOT** be installed within 20 cm of) any person.

You **MUST** cease operating this device immediately if requested by the ISED or a licensed wireless service provider.

WARNING. E911 location information may not be provided or may be inaccurate for calls served by using this device.

This device may be operated **ONLY** in a fixed location for in-building use.

CPC-2-1-05 — Zone Enhancers - Spectrum management and telecommunications
<http://www.ic.gc.ca/eic/site/smt-gst.nsf/eng/sf08942.html>

Mobile phone is the minimum distance to use indoor antenna	
Inside server antenna types	Minimum separation distances D (m)
Ceiling mounted (e.g., dome-type) antennas	2
Wall mounted (i.e., panel or other type) antennas	1.0 or 2*
Table top antennas	1.0

Warnings and Recommendations

- ⚠ Warning: This consumer booster is for Consumer use only.
- ⚠ Warning: Unauthorized antennas, cables, and/or coupling devices are prohibited by FCC regulations. Please contact FCC for details: 1-888-CALL-FCC.
- ⚠ Warning: Outside antenna orientation must be back side of inside antenna is to prevent the indoor antenna receiving the signal emitted by outside antenna. Otherwise it will cause self-oscillation of booster.
- ⚠ Warning: RF safety, any antenna used with this device must be located at 20 cm (8 inches) away from persons or by bystanders.
- ⚠ Warning: It will damage the mobile device and the booster if connect them with a cable directly.
- ⚠ Warning: Use the power supply provided by SolidRF only. Other power supplies may cause damage of the booster.
- ⚠ Warning: Antenna installation is restricted to 10 meters or less height above ground, even if the antenna is installed inside when used with a mobile device that operates in the 1710-1755 MHz band. Violation of this requirement may subject the owner of the booster to potential FCC enforcement actions.
- ⚠ Warning: Never point the front of a directional antenna toward the inside antenna. Verify that both the outside antenna and the inside antenna are connected to the booster before powering up the booster.

(EN) RF Exposure: The manufacturer's rated output power of this equipment is for single carrier operation. For situations when multiple carrier signals are present, the rating would have to be reduced by 3.5 dB, especially where the output is re-radiated and can cause interference to adjacent band users. This power reduction is to be by means of input power or gain reduction and not by an attenuating at the output of the device.

(FR) Exposition RF: La puissance de sortie nominale du fabricant de cet équipement est pour le fonctionnement d'une seule porteuse. Pour les situations où plusieurs signaux de porteuse sont présents, la note devrait être réduite de 3,5 dB, en particulier lorsque le signal de sortie est rayonné et peut causer des interférences aux utilisateurs de bande adjacents. Cette réduction de puissance doit se faire au moyen d'une puissance d'entrée ou d'une réduction de gain et non pas par un atténuateur à la sortie du dispositif.

(EN) This device complies with Industry Canada license-exempt RSS standard(s). Operation is subject to the following two conditions: (1) this device may not cause interference, and (2) this device must accept any interference, including interference that may cause undesired operation of the device.

(FR) Le présent appareil est conforme aux CNR d'Industrie Canada applicables aux appareils radio exempts de licence. L'exploitation est autorisée aux deux conditions suivantes : (1) l'appareil ne doit pas produire de brouillage, et (2) l'utilisateur de l'appareil doit accepter tout brouillage radioélectrique subi, même si le brouillage est susceptible d'en compromettre le fonctionnement.

(EN) This system has been evaluated for RF Exposure per RSS-102 and is in compliance with the limits specified by Health Canada Safety Code 6. The system must be installed at a minimum separation distance from the antenna to a general bystander of 8 inches (20 cm) to maintain compliance with the General Population limits.

(FR) L'exposition aux radiofréquences de ce système a été évaluée selon la norme RSS -102 et est jugée conforme aux limites établies par le Code de sécurité 6 de Santé Canada. Le système doit être installé à une distance minimale de 8 pouces (20 cm) séparant l'antenne d'une personne présente en conformité avec les limites permises d'exposition au grand public.

Antenna Kitting Information

Component	Type specification	Gain/Loss					Manufacturer
		LTE-707	LTE-781	800MHz	1900MHz	1700MHz\2100MHz	
Outside Cable	LMR240 45Feet	2.9dB	3.15dB	3.38dB	4.87dB	4.87dB\5.2dB	Suirongcable
Outside Cable	SRLMR400-30NN 30Feet	1.9dB	1.9dB	1.95dB	2.9dB	2.55dB\2.9dB	Suirongcable
Inside Cable	RG6FF 90Feet	4.3dB	4.6dB	5dB	7.6dB	6.6dB\8.4dB	Suirongcable
Inside Cable	RG6FF 75Feet	3.6dB	3.8dB	4.2dB	6.3dB	5.5dB\7dB	Suirongcable
Inside Cable	RG6FF 60Feet	2.9dB	3.0dB	3.3dB	5dB	4.4dB\5.6dB	Suirongcable
Inside Cable	RG6FF 45Feet	2.2dB	2.3dB	2.5 dB	3.8 dB	3.3 dB\4.2dB	Suirongcable
Inside Cable	LMR240 90Feet	5.85dB	6.3 dB	6.75 dB	9.9 dB	9.9dB\10.35dB	Suirongcable
Inside Cable	LMR240 75Feet	4.88dB	5.25dB	5.63dB	8.25dB	8.25\8.63 dB	Suirongcable
Inside Cable	LMR240 60Feet	3.9dB	4.2dB	4.5dB	6.6dB	6.6 dB\6.9 dB	Suirongcable
Inside Cable	LMR240 45Feet	2.9dB	3.15dB	3.38dB	4.87dB	4.87dB\5.2dB	Suirongcable
Inside Cable	SRLMR400-30NN 30Feet	1.9dB	1.9dB	1.95dB	2.9dB	2.55dB\2.9dB	Suirongcable
Inside Cable	SRLMR400-75NN 75Feet	4.2dB	4.2dB	4.4dB	6.1dB	5.8dB\6.5dB	Suirongcable
Inside Cable	SRG58-30FN 30Feet	4.5dB	4.5dB	4.9dB	7.6dB	7.2dB\8dB	Suirongcable
Inside Cable	SRLMR400-20NN 20Feet	1.3dB	1.3dB	1.35dB	1.8dB	1.8dB\1.9dB	Suirongcable
Inside Cable	SRG58-15FN 15Feet	2.35dB	2.4dB	2.56dB	3.9dB	3.7dB\ 4.1dB	Suirongcable
Inside Cable	SRLMR400-30NN 30Feet	1.9dB	1.9dB	1.95dB	2.8dB	2.55dB\2.9dB	Suirongcable
Outside Antenna	ANT050701	7dBi	7dBi	7dBi	10dBi	10dBi\10dBi	Shenzhen Dachi Communications Co., Ltd.
Outside Antenna	ANT010901	9dBi	9dBi	9dBi	9dBi	9dBi	Shenzhen Dachi Communications Co., Ltd.
Outside Antenna	ANT010701	9dBi	9dBi	9dBi	9dBi	9dBi	Shenzhen Dachi Communications Co., Ltd.
Outside Antenna	ANT060302	3dBi	3dBi	3dBi	3.5dBi	3.5dBi\3.5dBi	Shenzhen Dachi Communications Co., Ltd.
Outside Antenna	ANT030301	3dBi	3dBi	3dBi	3dBi	3dBi	Shenzhen Dachi Communications Co., Ltd.
Outside Antenna	ANT060302	3dBi	3dBi	3dBi	3.5dBi	3.5dBi\3.5dBi	Shenzhen Dachi Communications Co., Ltd.
Outside Antenna	ANT030301	3dBi	3dBi	3dBi	3dBi	3dBi	Shenzhen Dachi Communications Co., Ltd.
Inside Antenna	ANT050701	7dBi	7dBi	7dBi	10dBi	10dBi\10dBi	Shenzhen Dachi Communications Co., Ltd.
Inside Antenna	ANT010901	9dBi	9dBi	9dBi	9dBi	9dBi	Shenzhen Dachi Communications Co., Ltd.
Inside Antenna	ANT010701	9dBi	9dBi	9dBi	9dBi	9dBi	Shenzhen Dachi Communications Co., Ltd.
Inside Antenna	ANT060302	3dBi	3dBi	3dBi	3.5dBi	3.5dBi\3.5dBi	Shenzhen Dachi Communications Co., Ltd.
Inside Antenna	ANT040301	3dBi	3dBi	3dBi	3dBi	3dBi	Shenzhen Dachi Communications Co., Ltd.
Inside Antenna	ANT080301	3dBi	3dBi	3dBi	3dBi	3dBi	Shenzhen Dachi Communications Co., Ltd.
Inside Antenna	ANT080302	3dBi	3dBi	3dBi	3dBi	3dBi	Shenzhen Dachi Communications Co., Ltd.
Inside Antenna	ANT060301	3dBi	3dBi	3dBi	3dBi	3dBi	Shenzhen Dachi Communications Co., Ltd.
Inside Antenna	ANT060303	3dBi	3dBi	3dBi	3dBi	3dBi	Shenzhen Dachi Communications Co., Ltd.
Inside Antenna	ANT070101	1dBi	1dBi	1dBi	1dBi	1dBi	Shenzhen Dachi Communications Co., Ltd.
Inside Antenna	SR-21300100	3dBi	3dBi	3dBi	3.5dBi	3.5dBi\3.5dBi	Shenzhen Dachi Communications Co., Ltd.
Lightning Protector	ACC010101	0.1 dB	0.1 dB	0.1 dB	0.18dB	0.16dB\0.2dB	Shenzhen Dachi Communications Co., Ltd.

All equivalent antennas and cables are suitable for use with the SolidRF booster.

Default combination

TRUE5-D+ANT050701+SRLMR400-30NN 30Feet+SRLMR400-75NN 75Feet+ANT010901