



RADIO TEST REPORT

Test Report No. : 30GE0186-HO-01-A

Applicant : YAMAHA CORPORATION
Type of Equipment : Wireless Transmitter for iPod
Model No. : YIT-W11TX
FCC ID : A6RYITW11TXA
Test regulation : FCC Part 15 Subpart C 2010
Section 15.207, Section 15.247
(Permissive Change Class II Application)
Test Result : Complied

1. This test report shall not be reproduced in full or partial, without the written approval of UL Japan, Inc.
2. The results in this report apply only to the sample tested.
3. This sample tested is in compliance with the above regulation.
4. The test results in this report are traceable to the national or international standards.
5. This test report must not be used by the customer to claim product certification, approval, or endorsement by NVLAP, NIST, or any agency of the Federal Government.

Date of test: March 9 to 16, 2010

Tested by: 
Takeshi Choda
Representative test engineer
of EMC Service

Approved by: 
Makoto Kosaka
Engineer of EMC Service



NVLAP LAB CODE: 200572-0

This laboratory is accredited by the NVLAP LAB CODE 200572-0, U.S.A. The tests reported herein have been performed in accordance with its terms of accreditation.
*As for the range of Accreditation in NVLAP, you may refer to the WEB address, <http://uljapan.co.jp/emc/nvlap.html>

CONTENTS	PAGE
SECTION 1: Customer information.....	3
SECTION 2: Equipment under test (E.U.T.).....	3
SECTION 3: Test specification, procedures & results.....	4
SECTION 4: Operation of E.U.T. during testing.....	7
SECTION 5: Conducted Emission.....	9
SECTION 6: Radiated Spurious Emission	10
SECTION 7: Antenna Terminal Conducted Tests.....	11
APPENDIX 1: Photographs of test setup	12
Conducted Emission	12
Radiated Spurious Emission	13
Worst Case Position (Horizontal: Z-axis/ Vertical:Y-axis)	15
APPENDIX 2: Data of EMI test.....	16
Conducted Emission	16
6dB Bandwidth	19
Maximum Peak Output Power	21
Radiated Spurious Emission	22
Conducted Spurious Emission	31
Conducted Emission Band Edge compliance	35
Power Density	36
99%Occupied Bandwidth	38
APPENDIX 3: Test instruments	39

SECTION 1: Customer information

Company Name : YAMAHA CORPORATION
Address : 10-1 Nakazawa-cho, Naka-ku, Hamamatsu-shi, Shizuoka 430-8650, Japan
Telephone Number : +81-53-460-3320
Facsimile Number : +81-53-460-2878
Contact Person : Akira Urushibata

SECTION 2: Equipment under test (E.U.T.)

2.1 Identification of E.U.T.

Type of Equipment : Wireless Transmitter for iPod
Model No. : YIT-W11TX
Serial No. : Refer to Section 4, Clause 4.2
Rating : DC 3.3V
Receipt Date of Sample : March 9, 2010
Country of Mass-production : China
Condition of EUT : Production prototype
(Not for Sale: This sample is equivalent to mass-produced items.)
Modification of EUT : No Modification by the test lab

2.2 Product Description

Feature of EUT: Transmitter for Apple iPod / iPhone with the wireless audio communication to various YAMAHA audio products. (Desktop Audio System: TSX-W80 and Micro Component System MCR-140).

General Specification

Clock frequencies in the system : 12.288MHz (RF reference clock), 24.576MHz (CODEC audio clock)

Radio Specification

Equipment Type	Transceiver
Frequency of Operation	2405.376-2473.984MHz
Type of Modulation	GFSK
Bandwidth	7MHz
Antenna Type	PCB pattern antenna
Antenna Gain	0.1dBi
Method of Frequency Generation	Crystal

<Contents of the change from original model>

Original test report number of this report is 29KE0002-HO-02-A.

The EUT is changed the specification from original model as below.

- * The form change of pattern antenna
- * The position change of RF module on a board
- * Removed pattern antenna
- * The change of Antenna Gain

UL Japan, Inc.

Head Office EMC Lab.

4383-326 Asama-cho, Ise-shi, Mie-ken 516-0021 JAPAN

Telephone : +81 596 24 8116

Facsimile : +81 596 24 8124

SECTION 3: Test specification, procedures & results

3.1 Test Specification

Test Specification : FCC Part15 Subpart C: 2010, final revised on January 22, 2010 and effective March 1, 2010

Title : FCC 47CFR Part15 Radio Frequency Device Subpart C Intentional Radiators
Section 15.207 Conducted limits
Section 15.247 Operation within the bands 902-928MHz,
2400-2483.5MHz, and 5725-5850MHz

3.2 Procedures and results

Item	Test Procedure	Specification	Worst margin	Results	Remarks
Conducted Emission	FCC: ANSI C63.4:2003 7. AC powerline Conducted Emission measurements ----- IC: RSS-Gen 7.2.2	FCC: Section 15.207 ----- IC: RSS-Gen 7.2.2	QP 17.0dB, 0.15000MHz, L AV 26.0dB, 0.17228MHz, L	Complied	-
6dB Bandwidth	FCC: "Guidance on Measurement of Digital Transmission Systems Operating under Section15.247" ----- IC: RSS-Gen 4.6.2	FCC: Section 15.247(a)(2) ----- IC: RSS-210 A8.2(a)	See data.	Complied	Conducted
Maximum Peak Output Power	FCC: "Guidance on Measurement of Digital Transmission Systems Operating under Section15.247" ----- IC: RSS-Gen 4.8	FCC: Section 15.247(b)(3) ----- IC: RSS-210 A8.4(4)		Complied	Conducted
Power Density	FCC: "Guidance on Measurement of Digital Transmission Systems Operating under Section15.247" ----- IC: -	FCC: Section 15.247 (e) ----- IC: RSS-210 A8.2(b)		Complied	Conducted
Spurious Emission Restricted Band Edges	FCC: "Guidance on Measurement of Digital Transmission Systems Operating under Section15.247" ----- IC: RSS-Gen 4.9 RSS-Gen 4.10	FCC: Section15.247(d) ----- IC: RSS-210 A8.5 RSS-Gen 7.2.1 and 7.2.3	[Tx] 0.6dB 4947.968MHz, AV, Hori. (when used apart) [Rx] 18.3dB 67.878MHz, QP, Hori.	Complied	Conducted/ Radiated

Note: UL Japan, Inc.'s EMI Work Procedures No.QPM05 and QPM15.

* In case any questions arise about test procedure, ANSI C63.4: 2003 is also referred.

FCC 15.31 (e)

This EUT (a plug-in radio device) is provided stable voltage (DC 3.3V) constantly to RF part regardless of input voltage via host equipment (iPod). Therefore, this EUT complies with the requirement.

FCC Part 15.203 Antenna requirement

It is impossible for end users to replace the antenna, because the antenna is mounted inside of the EUT. Therefore, the equipment complies with the antenna requirement of Section 15.203.

UL Japan, Inc.

Head Office EMC Lab.

4383-326 Asama-cho, Ise-shi, Mie-ken 516-0021 JAPAN

Telephone : +81 596 24 8116

Facsimile : +81 596 24 8124

3.3 Addition to standard

Item	Test Procedure	Specification	Worst margin	Results	Remarks
99% Occupied Bandwidth	IC: RSS-Gen 4.6.1	IC: RSS-Gen 4.6.1	N/A	N/A	Conducted

Other than above, no addition, exclusion nor deviation has been made from the standard.

3.4 Uncertainty

EMI

The following uncertainties have been calculated to provide a confidence level of 95% using a coverage factor k=2.

Test room (semi-anechoic chamber)	Conducted emission (+dB)
	150kHz-30MHz
No.1	2.6dB
No.2	2.9dB
No.3	3.3dB
No.4	2.8dB

Test room (semi-anechoic chamber)	Radiated emission (10m*)(+dB)			Radiated emission					
				(3m*)(+dB)					(1m*)(+dB)
	9kHz -30MHz	30MHz -300MHz	300MHz -1GHz	9kHz -30MHz	30MHz -300MHz	300MHz -1GHz	1GHz -18GHz	18GHz -26.5GHz	26.5GHz -40GHz
No.1	2.7dB	4.8dB	5.0dB	2.9dB	4.8dB	5.0dB	3.9dB	4.5dB	4.4dB
No.2	-	-	-	3.5dB	4.8dB	5.1dB	4.0dB	4.3dB	4.2dB
No.3	-	-	-	3.8dB	4.6dB	4.7dB	4.0dB	4.5dB	4.4dB
No.4	-	-	-	3.5dB	4.4dB	4.9dB	4.0dB	4.6dB	4.5dB

*10m/3m/1m = Measurement distance

Power meter (+dB)	
Below 1GHz	Above 1GHz
1.0dB	1.0dB

Antenna terminal conducted emission and Power density (+dB)			Antenna terminal conducted emission (+dB)		Channel power (±dB)
Below 1GHz	1GHz-3GHz	3GHz-18GHz	18GHz-26.5GHz	26.5GHz-40GHz	
1.0dB	1.1dB	2.7dB	3.2dB	3.3dB	1.5dB

Conducted Emission test

The data listed in this test report has enough margin, more than the site margin.

Radiated emission test(3m)

[Tx] The data listed in this report meets the limits unless the uncertainty is taken into consideration.

[Rx] The data listed in this test report has enough margin, more than the site margin.

UL Japan, Inc.

Head Office EMC Lab.

4383-326 Asama-cho, Ise-shi, Mie-ken 516-0021 JAPAN

Telephone : +81 596 24 8116

Facsimile : +81 596 24 8124

3.5 Test Location

UL Japan, Inc. Head Office EMC Lab. *NVLAP Lab. code: 200572-0
4383-326 Asama-cho, Ise-shi, Mie-ken 516-0021 JAPAN
Telephone : +81 596 24 8116 Facsimile : +81 596 24 8124

	FCC Registration Number	IC Registration Number	Width x Depth x Height (m)	Size of reference ground plane (m) / horizontal conducting plane	Other rooms
No.1 semi-anechoic chamber	313583	2973C-1	19.2 x 11.2 x 7.7m	7.0 x 6.0m	No.1 Power source room
No.2 semi-anechoic chamber	655103	2973C-2	7.5 x 5.8 x 5.2m	4.0 x 4.0m	-
No.3 semi-anechoic chamber	148738	2973C-3	12.0 x 8.5 x 5.9m	6.8 x 5.75m	No.3 Preparation room
No.3 shielded room	-	-	4.0 x 6.0 x 2.7m	N/A	-
No.4 semi-anechoic chamber	134570	2973C-4	12.0 x 8.5 x 5.9m	6.8 x 5.75m	No.4 Preparation room
No.4 shielded room	-	-	4.0 x 6.0 x 2.7m	N/A	-
No.5 semi-anechoic chamber	-	-	6.0 x 6.0 x 3.9m	6.0 x 6.0m	-
No.6 shielded room	-	-	4.0 x 4.5 x 2.7m	4.75 x 5.4 m	-
No.6 measurement room	-	-	4.75 x 5.4 x 3.0m	4.75 x 4.15 m	-
No.7 shielded room	-	-	4.7 x 7.5 x 2.7m	4.7 x 7.5m	-
No.8 measurement room	-	-	3.1 x 5.0 x 2.7m	N/A	-
No.9 measurement room	-	-	8.0 x 4.5 x 2.8m	2.0 x 2.0m	-
No.10 measurement room	-	-	2.6 x 2.8 x 2.5m	2.4 x 2.4m	-
No.11 measurement room	-	-	3.1 x 3.4 x 3.0m	2.4 x 3.4m	-

* Size of vertical conducting plane (for Conducted Emission test) : 2.0 x 2.0m for No.1, No.2, No.3, and No.4 semi-anechoic chambers and No.3 and No.4 shielded rooms.

3.6 Test set up, Data of EMI, and Test instruments

Refer to APPENDIX.

SECTION 4: Operation of E.U.T. during testing

4.1 Operating Mode(s)

*The details of operating mode(s)

Test Item	Operating Mode	Tested frequency
Conducted Emission	Transmitting (Tx) -when Docked	2405.376MHz 2436.096MHz 2473.984MHz
	Receiving (Rx) -when Docked	2436.096MHz
6dB Bandwidth Maximum Peak Output Power Power Density 99% Occupied Bandwidth	Transmitting (Tx)	2405.376MHz 2436.096MHz 2473.984MHz
Radiated Spurious Emission	Transmitting (Tx) -when used apart -when Docked	2405.376MHz 2436.096MHz 2473.984MHz
	Receiving (Rx) -when used apart -when Docked	2436.096MHz
Conducted Spurious Emission	Transmitting (Tx)	2405.376MHz 2436.096MHz 2473.984MHz
	Receiving (Rx)	2436.096MHz
Conducted Emission Band Edge compliance	Transmitting (Tx)	2405.376MHz 2473.984MHz

4.2 Configuration and peripherals

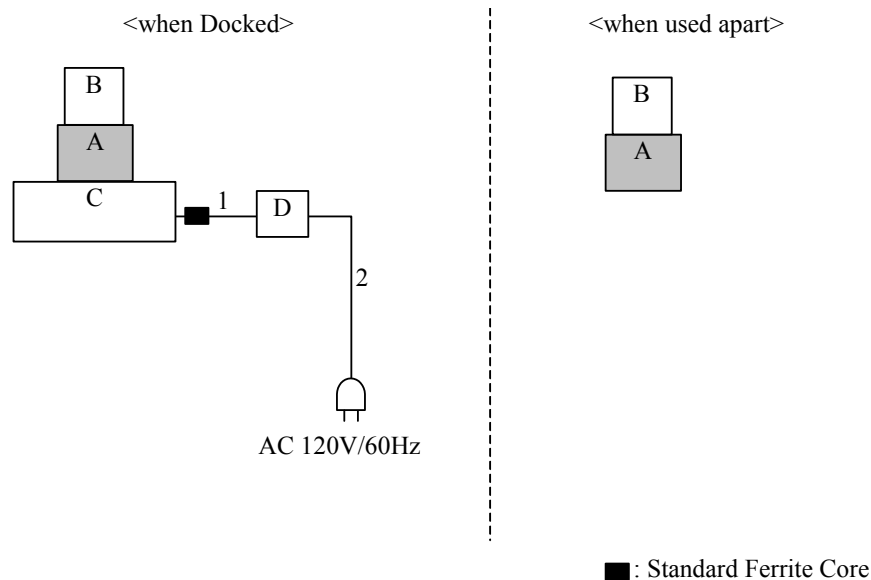

* Cabling and setup(s) were taken into consideration and test data was taken under worse case conditions.

Description of EUT

No.	Item	Model number	Serial number	Manufacturer	Remarks
A	Wireless Transmitter for iPod	YIT-W11TX	IR25-001	YAMAHA CORPORATION	EUT
B	iPod classic	A1238	8M8368KRC25	Apple	-
C	Desktop Audio System	TSX-W80	E010339SU	YAMAHA CORPORATION	-
D	AC Adaptor	NU40-2150266-I3	WT53960	YAMAHA CORPORATION	-

List of cables used

No.	Name	Length (m)	Shield		Remarks
			Cable	Connector	
1	DC Cable	1.8	Unshielded	Unshielded	-
2	AC Cable	1.8	Unshielded	Unshielded	-

SECTION 5: Conducted Emission

Test Procedure and conditions

EUT was placed on a urethane platform of nominal size, 0.5m by 1.0m, raised 0.8m above the conducting ground plane.

The rear of tabletop was located 40cm to the vertical conducting plane. The rear of EUT, including peripherals aligned and flushed with rear of tabletop. All other surfaces of tabletop were at least 80cm from any other grounded conducting surface. EUT was located 80cm from a Line Impedance Stabilization Network (LISN)/ Artificial mains Network (AMN) and excess AC cable was bundled in center.

For the tests on EUT with other peripherals (as a whole system)

I/O cables that were connected to the peripherals were bundled in center. They were folded back and forth forming a bundle 30cm to 40cm long and were hanged at a 40cm height to the ground plane. All unused 50ohm connectors of the LISN(AMN) were resistivity terminated in 50ohm when not connected to the measuring equipment.

The AC Mains Terminal Continuous disturbance Voltage has been measured with the EUT in a Semi Anechoic Chamber or a Measurement Room.

The EUT was connected to a LISN (AMN).

An overview sweep with peak detection has been performed.

The test results and limit are rounded off to one decimal place, so some differences might be observed.

Detector	: QP and AV
Measurement range	: 0.15-30MHz
Test data	: APPENDIX
Test result	: Pass

UL Japan, Inc.

Head Office EMC Lab.

4383-326 Asama-cho, Ise-shi, Mie-ken 516-0021 JAPAN

Telephone : +81 596 24 8116

Facsimile : +81 596 24 8124

SECTION 6: Radiated Spurious Emission

Test Procedure

It was measured based on "2. Radiated emission test" of "Guidance on Measurement of Digital Transmission Systems Operating under Section15.247".

EUT was placed on a urethane platform of nominal size, 0.5m by 1.0m, raised 0.8m above the conducting ground plane.

The Radiated Electric Field Strength has been measured in a Semi Anechoic Chamber with a ground plane.

The height of the measuring antenna varied between 1 and 4m and EUT was rotated a full revolution in order to obtain the maximum value of the electric field strength.

The measurements were performed for both vertical and horizontal antenna polarization with the Test Receiver, or the Spectrum Analyzer.

The measurements were made with the following detector function of the test receiver and the Spectrum analyzer (in linear mode).

The test was made with the detector (RBW/VBW) in the following table.

When using Spectrum analyzer, the test was made with adjusting span to zero by using peak hold.

Test Antennas are used as below;

Frequency	Below 30MHz	30MHz to 300MHz	300MHz to 1GHz	Above 1GHz
Antenna Type	Loop	Biconical	Logperiodic	Horn

In any 100kHz bandwidth outside the restricted band in which the spread spectrum intentional radiator is operating, the radio frequency power that is produced by the intentional radiator confirmed 20dB below that in the 100kHz bandwidth within the band that contains the highest level of the desired power, based on a radiated measurement.

20dBc was applied to the frequency over the limit of FCC 15.209 / Table 2 of RSS-210 2.7 (IC) and outside the restricted band of FCC15.205 / Table 1 of RSS-210 2.7 (IC).

Frequency	Below 1GHz	Above 1GHz	
Instrument used	Test Receiver / Spectrum Analyzer	Spectrum Analyzer	
Detector	QP	PK	AV
IF Bandwidth	BW 120kHz(T/R)	RBW: 1MHz VBW: 3MHz	RBW: 1MHz VBW: 10Hz
	20dBc : RBW: 100kHz VBW: 300kHz (S/A)	20dBc : RBW:100kHz/VBW:300kHz	
Test Distance	3m	3m (below 10GHz), 1m*1) (above 10GHz),	

*1) Distance Factor: $20 \times \log(3.0\text{m}/1.0\text{m}) = 9.5\text{dB}$

[when used apart]

- The carrier level and noise levels were confirmed at each position of X, Y and Z axes of EUT to see the position of maximum noise, and the test was made at the position that has the maximum noise.

[when Docked]

The test was made on EUT at the normal use position.

The test results and limit are rounded off to one decimal place, so some differences might be observed.

Measurement range : 30M-26.5GHz
Test data : APPENDIX
Test result : Pass

UL Japan, Inc.

Head Office EMC Lab.

4383-326 Asama-cho, Ise-shi, Mie-ken 516-0021 JAPAN

Telephone : +81 596 24 8116

Facsimile : +81 596 24 8124

SECTION 7: Antenna Terminal Conducted Tests

Test Procedure

The tests were made with below setting connected to the antenna port.

Test	Span	RBW	VBW	Sweep time	Detector	Trace	Instrument used
6dB Bandwidth	20MHz	100kHz	300kHz	Auto	Peak	Max Hold	Spectrum Analyzer
99% Occupied Bandwidth	Enough width to display 20dB Bandwidth	1 to 3% of Span	Three times of RBW	Auto	Peak	Max Hold	Spectrum Analyzer
Maximum Peak Output Power	-	-	-	Auto	Peak	-	Power Meter (Sensor: 50MHz BW)
Peak Power Density	1.5MHz	3kHz	100kHz	500sec	Peak	Max Hold	Spectrum Analyzer *1)
Conducted Spurious Emission	Less or equal to 5GHz (Range: 30MHz-25GHz)	100kHz	300kHz	Auto	Peak	Max Hold	Spectrum Analyzer

*1) PSD Option 1 of "Guidance on Measurement of Digital Transmission Systems Operating under Section15.247".

The test results and limit are rounded off to two decimals place, so some differences might be observed.

Test data : APPENDIX
Test result : Pass