

note) 1. Labels must be stuck to positions specified in BOTTOMCOVER printing instruction drawing
 2. Torque follows WORK GUIDE. If screws become unusable or can not be tightened completely.
 It may be changed to optimum torque.

注) 1. ラベル関係の貼付位置はボトムカバー印刷図による。
 2. ネジ締付トルクはWORK GUIDEを参照のこと。ただしネジ締付に問題がある場合は締付トルクを調整するものとする。

YBA-10SZ		
mark	version	part No.
J	Japan	WN55140
U	U. S. A.	WN55150
C	Canada	
T	China	WN55160
K	Korea	
A	Australia	WN55170
B	B. S	
G	Europe	
F	Russia	

No.	version	before passed	after passed	note
21	EX	✓		SEMKO, GOST mark must be masked
22	EX	✓		MIC, CE, C-Tick mark must be masked
25	EX		✓	LABEL/J must be stucked
26	EX		✓	CMII ID must be stucked

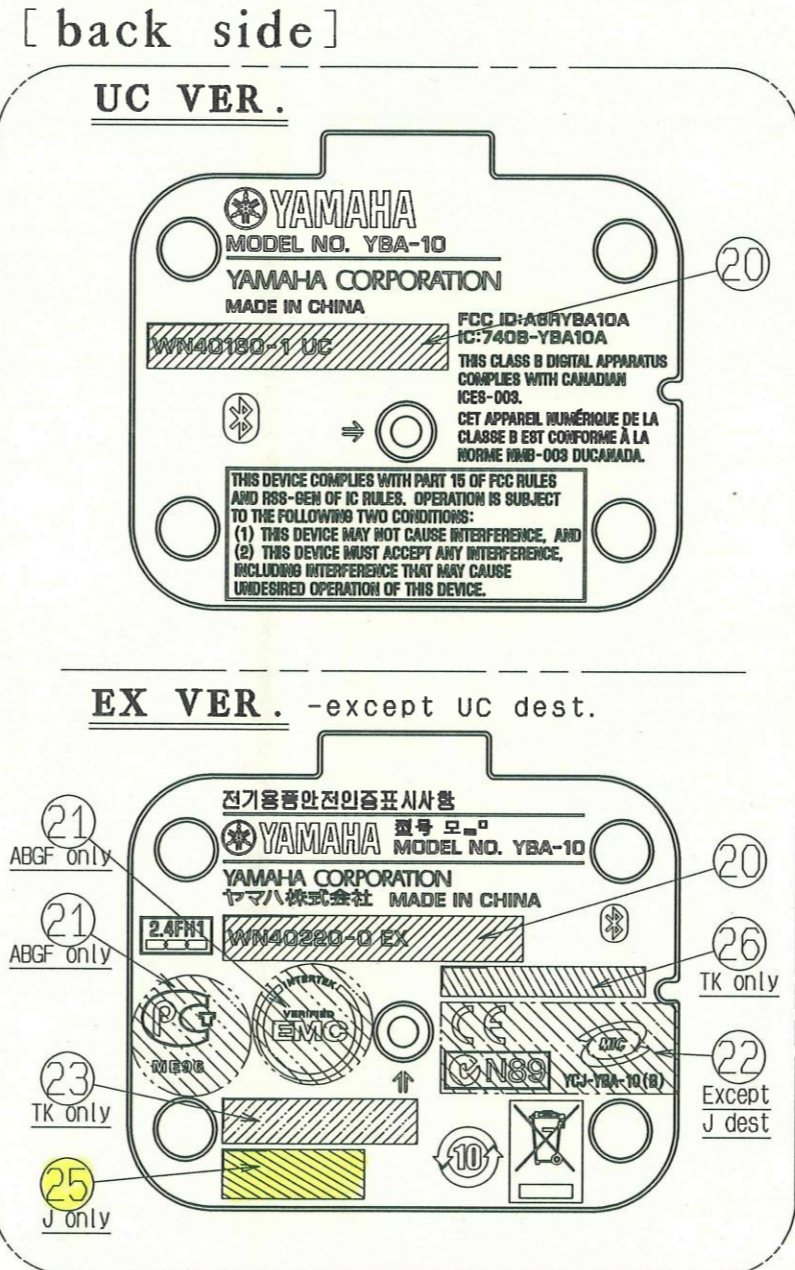
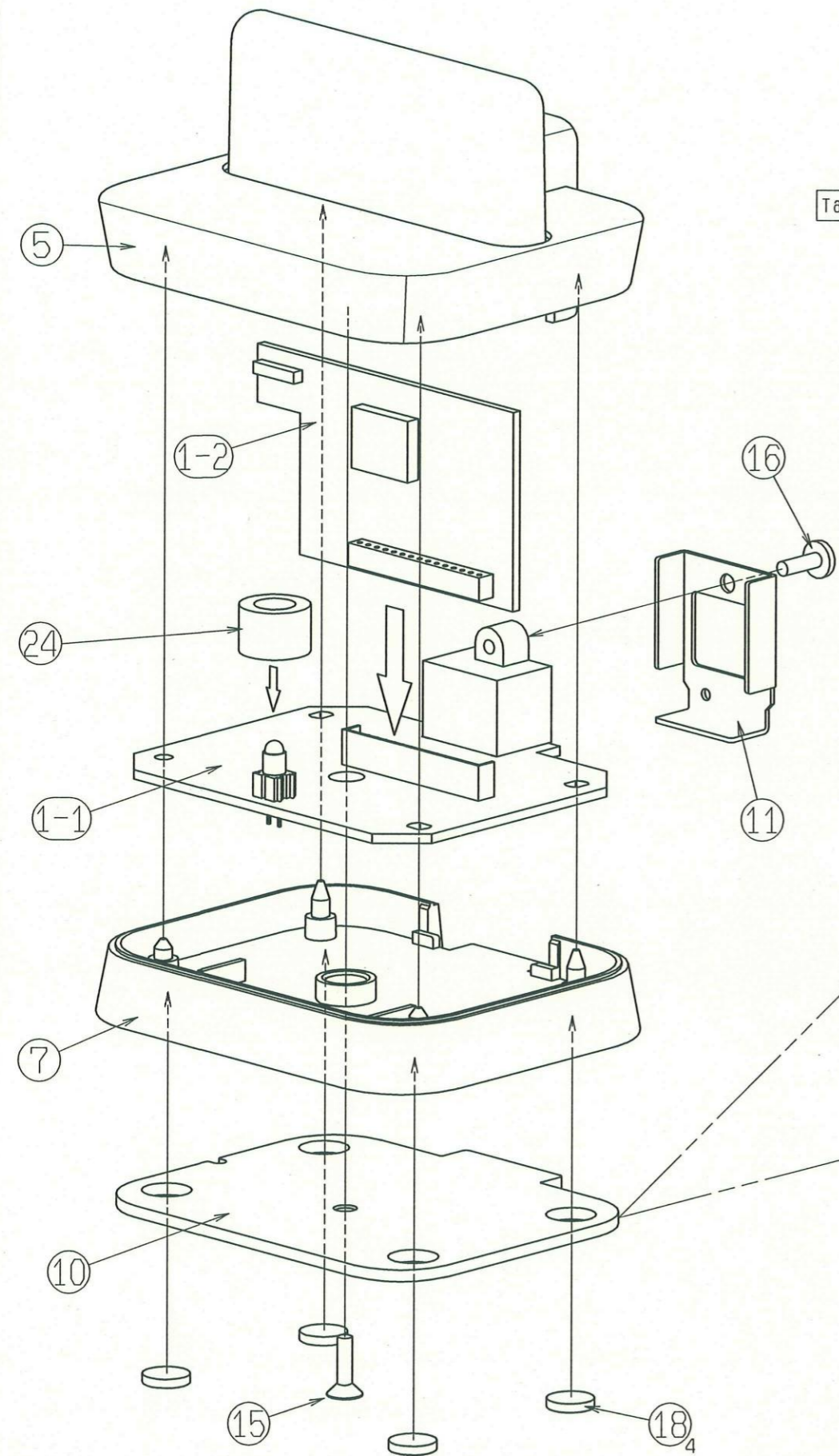

REV. CODE	COUNT	NO.	REVISION DESCRIPTION	DATE	DRAWN
1	4	6132604 6.1.3.3.5.2.1	Addition of parts etc.	17. DEC. '07	Sugisaki
0	-	-	New Issue 新規(初版)発行	-	Sugisaki

L	TOLERANCE	DOC SIZE	A3	APPROVED BY	DATE	ORIGINAL MODEL	MATERIAL
UP TO 30	±0.3	UNIT	mm	CHECKED BY	DATE	YBA-10SZ	FINISH, TREATMENT
OVER 30 ~ 80	±0.4	SCALE	1/1	DESIGNED BY	DATE		DOCUMENT NAME(E)
80 ~ 180	±0.6	TRIGONOMETRY		Sugisaki	18-OCT-'07		UNIVERSAL FINAL ASSY
180 ~ 310	±0.8			DRAWN BY	DATE		DOCUMENT NAME(J)
310 ~ 500	±1.0			Sugisaki	18-OCT-'07		ユニバーサル 総組立
500 ~	±1.3	DOC NO.	2,00,1,0,3,1,2,7,0	SORT NO.		ORIGINAL PART NO.	W,N,5,5,1,4,0
						PAGE CONTROL NO.	REV 0,0,1