



RF TEST REPORT

Applicant MOBILE DEVICES INGENIERIE
FCC ID A6GC4D-4G4USV7
Product OBDV7+ 4G CAT4 US
Brand T-Mobile, Metro, Munic
Model C4D-4G4USAB_V7+
Marketing C4D-4G4USAB_V7+
Report No. R1906A0298-R3
Issue Date August 6, 2019

TA Technology (Shanghai) Co., Ltd. tested the above equipment in accordance with the requirements in **FCC CFR47 Part 2 (2018)/ FCC CFR47 Part 27C (2018)**. The test results show that the equipment tested is capable of demonstrating compliance with the requirements as documented in this report.

Performed by: Peng Tao

Approved by: Kai Xu

TA Technology (Shanghai) Co., Ltd.

No.145, Jintang Rd, Tangzhen Industry Park, Pudong Shanghai, China

TEL: +86-021-50791141/2/3

FAX: +86-021-50791141/2/3-8000



TABLE OF CONTENT

1 Test Laboratory.....	4
1.1 Notes of the Test Report.....	4
1.2 Test facility.....	4
1.3 Testing Location.....	5
2 General Description of Equipment under Test.....	6
3 Applied Standards.....	7
4 Test Configuration.....	8
5 Test Case Results.....	9
5.1 RF Power Output.....	9
5.2 Effective Isotropic Radiated Power.....	19
5.3 Radiates Spurious Emission.....	26
6 Main Test Instruments.....	35
ANNEX A: EUT Appearance and Test Setup.....	36
A.1 EUT Appearance.....	36
A.2 Test Setup.....	37



Summary of Measurement Results

Number	Test Case	Clause in FCC rules	Verdict
1	RF power output	2.1046	PASS
2	Effective Isotropic Radiated power	27.50(d)(4) /27.50(c)(10)	Reference module report
3	Occupied Bandwidth	2.1049	Reference module report
4	Band Edge Compliance	27.53(h) /27.53(g)	Reference module report
5	Peak-to-Average Power Ratio	27.50(d)/KDB971168 D01(5.7)	Reference module report
6	Frequency Stability	2.1055 / 27.54	Reference module report
7	Spurious Emissions at Antenna Terminals	2.1051 /27.53(h) /27.53(g)	Reference module report
2	Radiates Spurious Emission	2.1053 /27.53(h) /27.53(g)	PASS
Note: PASS: The EUT complies with the essential requirements in the standard. FAIL: The EUT does not comply with the essential requirements in the standard.			
Date of Testing: June 27, 2019 ~ July 14, 2019			

Only Radiates Spurious Emission and RF power output were tested for C4D-4G4USAB_V7+ in this report. Other conducted test items refer to the LE910C4-NF Module report (Report No. : 1870209R-HPUSP17V00 and 1870209R-HPUSP17V00-A).



1 Test Laboratory

1.1 Notes of the Test Report

This report shall not be reproduced in full or partial, without the written approval of **TA technology (shanghai) co., Ltd.** The results documented in this report apply only to the tested sample, under the conditions and modes of operation as described herein .Measurement Uncertainties were not taken into account and are published for informational purposes only. This report is written to support regulatory compliance of the applicable standards stated above.

1.2 Test facility

FCC (Designation number: CN1179, Test Firm Registration Number: 446626)

TA Technology (Shanghai) Co., Ltd. has been listed on the US Federal Communications Commission list of test facilities recognized to perform electromagnetic emissions measurements.

IC (recognition number is 8510A)

TA Technology (Shanghai) Co., Ltd. has been listed by industry Canada to perform electromagnetic emission measurement.

VCCI (recognition number is C-4595, T-2154, R-4113, G-10766)

TA Technology (Shanghai) Co., Ltd. has been listed by industry Japan to perform electromagnetic emission measurement.

A2LA (Certificate Number: 3857.01)

TA Technology (Shanghai) Co., Ltd. has been listed by American Association for Laboratory Accreditation to perform electromagnetic emission measurement.



1.3 Testing Location

Company: TA Technology (Shanghai) Co., Ltd.
Address: No.145, Jintang Rd, Tangzhen Industry Park, Pudong Shanghai, China
City: Shanghai
Post code: 201201
Country: P. R. China
Contact: Xu Kai
Telephone: +86-021-50791141/2/3
Fax: +86-021-50791141/2/3-8000
Website: <http://www.ta-shanghai.com>
E-mail: xukai@ta-shanghai.com

2 General Description of Equipment under Test

Client Information

Applicant	MOBILE DEVICES INGENIERIE
Applicant address	100 AVENUE DE STALINGRAD VILLEJUIF, France
Manufacturer	MOBILE DEVICES INGENIERIE
Manufacturer address	100 AVENUE DE STALINGRAD VILLEJUIF, France

General information

EUT Description			
Model	C4D-4G4USAB_V7+		
IMEI/MEID/SN	354328090017986		
Hardware Version	SAP00422+SAP00421		
Software Version	V2107		
Power Supply	Battery		
Antenna Type	metallic antenna		
Antenna Gain	1dBi		
Test Mode(s)	WCDMA Band IV; LTE Band 4; LTE Band 12, LTE Band 66; LTE Band 71		
Test Modulation	(WCDMA) BPSK, QPSK, 16QAM; (LTE) QPSK 16QAM;		
HSDPA UE Category	14		
HSUPA UE Category	14		
DC-HSDPA UE Category	14		
LTE Category	4		
Rated Power Supply Voltage:	12V		
Extreme Voltage	Minimum: 8V Maximum: 18V		
Extreme Temperature	Lowest: -20°C Highest: +50°C		
Operating Frequency Range(s)	Mode	Tx (MHz)	Rx (MHz)
	WCDMA Band IV	1710 ~ 1755	2110 ~ 2155
	LTE Band 4	1710 ~ 1755	2110 ~ 2155
	LTE Band 12	699 ~ 716	729 ~ 746
	LTE Band 66	1710 ~ 1780	2110 ~ 2200
	LTE Band 71	663 ~ 698	617 ~ 652
EUT Accessory			
Battery	Manufacturer: HOWELL Energy Co., Ltd Model: Li-polymer 352535H		
Note: 1. The information of the EUT is declared by the manufacturer.			



3 Applied Standards

According to the specifications of the manufacturer, it must comply with the requirements of the following standards:

Test standards

FCC CFR47 Part 2 (2018)

FCC CFR47 Part 27C (2018)

ANSI C63.26 (2015)

KDB 971168 D01 Power Meas License Digital Systems v03r01

4 Test Configuration

Radiated measurements are performed by rotating the EUT in three different orthogonal test planes. EUT stand-up position (Z axis), lie-down position (X, Y axis). Receiver antenna polarization (horizontal and vertical), the worst emission was found in position (X axis, horizontal polarization) and the worst case was recorded.

All mode and data rates and positions and RB size and modulations were investigated. Subsequently, only the worst case emissions are reported.

The following testing in WCDMA/LTE is set based on the maximum RF Output Power.

The following testing in different Bandwidth is set to detail in the following table:

Test modes are chosen to be reported as the worst case configuration below for WCDMA Band IV:

Test items	Modes/Modulation
	WCDMA Band IV
RF power output	RMC/ AMR HSDPA/HSUPA DC-HSDPA
Radiates Spurious Emission	RMC

Test modes are chosen to be reported as the worst case configuration below for LTE Band 4/12/66/71:

Test items	Modes	Bandwidth (MHz)						Modulation		RB			Test Channel		
		1.4	3	5	10	15	20	QPSK	16QAM	1	50%	100%	L	M	H
RF power output	LTE 4	O	O	O	O	O	O	O	O	O	O	O	O	O	O
	LTE 12	O	O	O	O	-	-	O	O	O	O	O	O	O	O
	LTE 66	O	O	O	O	O	O	O	O	O	O	O	O	O	O
	LTE 71	-	-	O	O	O	O	O	O	O	O	O	O	O	O
Radiates Spurious Emission	LTE 4	O	-	O	-	-	O	O	-	O	-	-	-	O	-
	LTE12	O	O	-	O	-	-	O	-	O	-	-	-	O	-
	LTE 66	O	-	O	-	-	O	O	-	O	-	-	-	O	-
	LTE 71	-	-	O	-	-	O	O	-	O	-	-	-	O	-
Note	1. The mark "O" means that this configuration is chosen for testing. 2. The mark "-" means that this configuration is not testing.														

5 Test Case Results

5.1 RF Power Output

Ambient condition

Temperature	Relative humidity	Pressure
23°C ~25°C	45%~50%	101.5kPa

Methods of Measurement

During the process of the testing, The EUT is controlled by the Base Station Simulator to ensure max power transmission and proper modulation.

Test Setup

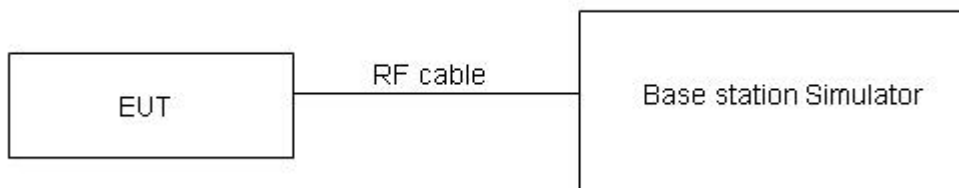

The loss between RF output port of the EUT and the input port of the tester has been taken into consideration.

Limits

No specific RF power output requirements in part 2.1046.

Measurement Uncertainty

The assessed measurement uncertainty to ensure 95% confidence level for the normal distribution is with the coverage factor $k = 2$, $U=0.4$ dB.



Test Results

WCDMA Band IV		Conducted Power(dBm)		
		Channel 1312	Channel 1413	Channel 1513
		1712.4 (MHz)	1732.6 (MHz)	1752.6(MHz)
RMC	12.2k	24.81	24.56	24.64
AMR	12.2k	24.15	23.89	23.99
HSDPA	Subtest 1	23.73	23.48	23.56
	Subtest 2	23.72	23.47	23.55
	Subtest 3	23.21	22.96	23.04
	Subtest 4	23.20	22.95	23.03
HSUPA	Subtest 1	23.69	23.44	23.52
	Subtest 2	22.68	22.43	22.51
	Subtest 3	23.16	22.92	23.00
	Subtest 4	22.65	22.41	22.49
	Subtest 5	23.64	23.40	23.48
DC-HSDPA	Subtest 1	23.65	23.42	23.48
	Subtest 2	23.64	23.41	23.47
	Subtest 3	23.22	22.90	22.98
	Subtest 4	23.21	22.89	22.97

LTE Band 4				AV Conducted Power(dBm)		
Bandwidth	Modulation	RB size	RB offset	Channel/Frequency (MHz)		
				19957/1710.7	20175/1732.5	20393/1754.3
1.4MHz	QPSK	1	0	24.18	24.20	24.30
		1	2	24.42	24.27	24.53
		1	5	24.07	24.14	24.35
		3	0	24.10	24.16	24.47
		3	2	24.04	24.15	24.26
		3	3	23.83	24.02	24.14
	16QAM	6	0	23.06	23.14	23.34
		1	0	22.93	22.82	23.30
		1	2	22.91	23.13	23.35
		1	5	22.45	22.94	23.28
		3	0	22.95	23.76	23.42
		3	2	22.75	23.21	23.40
		3	3	22.65	23.08	23.21
		6	0	21.66	22.13	22.49
Bandwidth	Modulation	RB size	RB offset	Channel/Frequency (MHz)		
				19965/1711.5	20175/1732.5	20385/1753.5
3MHz	QPSK	1	0	24.20	24.24	24.33



Bandwidth	Modulation	RB size	RB offset	Channel/Frequency (MHz)			
				19975/1712.5	20175/1732.5	20375/1752.5	
		1	7	24.40	24.30	24.57	
		1	14	24.10	24.19	24.39	
		8	0	23.20	23.28	23.60	
		8	4	23.16	23.25	23.38	
		8	7	22.93	23.13	23.24	
		15	0	23.06	23.18	23.37	
	16QAM	1	0	22.96	22.84	23.33	
		1	7	22.94	23.13	23.39	
		1	14	22.47	22.98	23.31	
		8	0	22.06	22.89	22.54	
		8	4	21.86	22.34	22.52	
		8	7	21.75	22.20	22.34	
			15	0	21.69	22.17	22.52
	Bandwidth	Modulation	RB size	RB offset	Channel/Frequency (MHz)		
19975/1712.5					20175/1732.5	20375/1752.5	
5MHz	QPSK	1	0	24.17	24.22	24.29	
		1	13	24.38	24.26	24.54	
		1	24	24.07	24.14	24.35	
		12	0	23.17	23.23	23.56	
		12	6	23.14	23.21	23.33	
		12	13	22.91	23.11	23.20	
	16QAM	25	0	23.06	23.17	23.35	
		1	0	22.93	22.80	23.30	
		1	13	22.91	23.11	23.36	
		1	24	22.44	22.96	23.27	
		12	0	22.04	22.85	22.51	
		12	6	21.83	22.29	22.48	
			12	13	21.72	22.15	22.30
			25	0	21.67	22.13	22.47
Bandwidth	Modulation	RB size	RB offset	Channel/Frequency (MHz)			
				20000/1715	20175/1732.5	20350/1750	
10MHz	QPSK	1	0	24.19	24.23	24.32	
		1	25	24.41	24.31	24.58	
		1	49	24.09	24.18	24.38	
		25	0	23.20	23.28	23.60	
		25	13	23.17	23.26	23.37	
		25	25	22.93	23.15	23.25	
	16QAM	50	0	23.10	23.19	23.39	
		1	0	22.95	22.83	23.32	
		1	25	22.94	23.15	23.39	
		1	49	22.47	22.98	23.30	
		25	0	22.07	22.90	22.55	
		25	13	21.85	22.33	22.51	



Bandwidth	Modulation	RB size	RB offset	Channel/Frequency (MHz)		
				20025/1717.5	20175/1732.5	20325/1747.5
15MHz	QPSK	25	25	21.75	22.20	22.34
		50	0	21.70	22.18	22.51
		1	0	24.18	24.19	24.30
		1	38	24.39	24.30	24.55
		1	74	24.06	24.13	24.34
		36	0	23.18	23.24	23.57
		36	18	23.14	23.21	23.33
	16QAM	36	39	22.90	23.12	23.21
		75	0	23.08	23.15	23.34
		1	0	22.90	22.81	23.30
		1	38	22.92	23.12	23.37
		1	74	22.44	22.94	23.27
		36	0	22.04	22.88	22.52
		36	18	21.82	22.28	22.47
20MHz	QPSK	36	39	21.73	22.16	22.31
		75	0	21.67	22.13	22.47
		1	0	24.15	24.15	24.27
		1	50	24.38	24.26	24.53
		1	99	24.04	24.12	24.31
		50	0	23.15	23.19	23.53
		50	25	23.12	23.17	23.30
	16QAM	50	50	22.87	23.07	23.17
		100	0	23.05	23.10	23.30
		1	0	22.73	22.77	23.25
		1	50	22.88	23.10	23.33
		1	99	22.42	22.91	23.25
		50	0	22.01	22.84	22.49
		50	25	21.79	22.26	22.44
LTE Band 12	QPSK	50	50	21.70	22.11	22.27
		100	0	21.65	22.09	22.44
		23017/699.7	23095/707.5	23173/715.3		
		1	0	24.55	24.41	24.27
		1	2	24.73	24.10	24.17
1.4MHz	QPSK	1	5	24.16	24.16	24.08
		3	0	24.62	24.34	23.90

LTE Band 12				AV Conducted Power(dBm)		
Bandwidth	Modulation	RB size	RB offset	Channel/Frequency (MHz)		
				23017/699.7	23095/707.5	23173/715.3
1.4MHz	QPSK	1	0	24.55	24.41	24.27
		1	2	24.73	24.10	24.17
		1	5	24.16	24.16	24.08
		3	0	24.62	24.34	23.90



	16QAM	3	2	24.45	24.13	23.89
		3	3	24.28	24.07	24.08
		6	0	23.38	23.26	22.87
		1	0	23.42	23.17	22.90
		1	2	23.40	23.04	23.04
		1	5	22.91	23.01	22.94
		3	0	23.73	23.56	22.60
		3	2	23.26	23.05	22.74
		3	3	23.08	23.09	22.89
6	0	22.35	22.22	21.95		
Bandwidth	Modulation	RB size	RB offset	Channel/Frequency (MHz)		
				23025/700.5	23095/707.5	23165/714.5
3MHz	QPSK	1	0	24.57	24.45	24.30
		1	7	24.71	24.13	24.21
		1	14	24.19	24.21	24.12
		8	0	23.72	23.46	23.03
		8	4	23.57	23.23	23.01
		8	7	23.38	23.18	23.18
		15	0	23.38	23.30	22.90
	16QAM	1	0	23.45	23.19	22.93
		1	7	23.43	23.04	23.08
		1	14	22.93	23.05	22.97
		8	0	22.84	22.69	21.72
		8	4	22.37	22.18	21.86
		8	7	22.18	22.21	22.02
		15	0	22.38	22.26	21.98
Bandwidth	Modulation	RB size	RB offset	Channel/Frequency (MHz)		
				23035/701.5	23095/707.5	23155/713.5
5MHz	QPSK	1	0	24.54	24.43	24.26
		1	13	24.69	24.09	24.18
		1	24	24.16	24.16	24.08
		12	0	23.69	23.41	22.99
		12	6	23.55	23.19	22.96
		12	13	23.36	23.16	23.14
		25	0	23.38	23.29	22.88
	16QAM	1	0	23.42	23.15	22.90
		1	13	23.40	23.02	23.05
		1	24	22.90	23.03	22.93
		12	0	22.82	22.65	21.69
		12	6	22.34	22.13	21.82
		12	13	22.15	22.16	21.98
		25	0	22.36	22.22	21.93
Bandwidth	Modulation	RB	RB offset	Channel/Frequency (MHz)		



		size		23060/704	23095/707.5	23130/711
10MHz	QPSK	1	0	24.52	24.36	24.24
		1	25	24.69	24.09	24.17
		1	49	24.13	24.14	24.04
		25	0	23.67	23.37	22.96
		25	13	23.53	23.15	22.93
		25	25	23.32	23.12	23.11
		50	0	23.37	23.22	22.83
	16QAM	1	0	23.10	23.12	22.85
		1	25	23.37	23.01	23.02
		1	49	22.88	22.98	22.91
		25	0	22.79	22.64	21.67
		25	13	22.30	22.10	21.78
		25	25	22.13	22.12	21.95
		50	0	22.34	22.18	21.90

LTE Band 66				AV Conducted Power(dBm)		
Bandwidth	Modulation	RB size	RB offset	Channel/Frequency (MHz)		
				131979/1710.7	132322/1745	132665/1779.3
1.4MHz	QPSK	1	0	23.99	24.19	24.00
		1	2	24.50	24.31	24.40
		1	5	24.04	23.88	23.96
		3	0	24.38	23.88	24.25
		3	2	24.23	23.85	23.97
		3	3	24.10	23.87	24.25
		6	0	23.11	22.89	23.07
	16QAM	1	0	23.63	22.57	23.52
		1	2	23.61	23.39	23.69
		1	5	22.81	23.17	23.33
		3	0	22.84	22.45	22.93
		3	2	22.87	22.57	22.69
		3	3	22.74	22.74	22.77
		6	0	21.78	21.66	21.87
Bandwidth	Modulation	RB size	RB offset	Channel	Channel	Channel
				131987/1711.5	132322/1745	132657/1778.5
3MHz	QPSK	1	0	24.01	24.23	24.03
		1	7	24.48	24.34	24.44
		1	14	24.07	23.93	24.00
		8	0	23.48	23.00	23.38
		8	4	23.35	22.95	23.09
		8	7	23.20	22.98	23.35
		15	0	23.11	22.93	23.10



	16QAM	1	0	23.66	22.59	23.55
		1	7	23.64	23.39	23.73
		1	14	22.83	23.21	23.36
		8	0	21.95	21.58	22.05
		8	4	21.98	21.70	21.81
		8	7	21.84	21.86	21.90
		15	0	21.81	21.70	21.90
Bandwidth	Modulation	RB size	RB offset	Channel	Channel	Channel
				131997/1712.5	132322/1745	132647/1777.5
5MHz	QPSK	1	0	23.98	24.21	23.99
		1	13	24.46	24.30	24.41
		1	24	24.04	23.88	23.96
		12	0	23.45	22.95	23.34
		12	6	23.33	22.91	23.04
		12	13	23.18	22.96	23.31
		25	0	23.11	22.92	23.08
	16QAM	1	0	23.63	22.55	23.52
		1	13	23.61	23.37	23.70
		1	24	22.80	23.19	23.32
		12	0	21.93	21.54	22.02
		12	6	21.95	21.65	21.77
		12	13	21.81	21.81	21.86
		25	0	21.79	21.66	21.85
Bandwidth	Modulation	RB size	RB offset	Channel	Channel	Channel
				132022/1715	132322/1745	132622/1775
10MHz	QPSK	1	0	24.00	24.22	24.02
		1	25	24.49	24.35	24.45
		1	49	24.06	23.92	23.99
		25	0	23.48	23.00	23.38
		25	13	23.36	22.96	23.08
		25	25	23.20	23.00	23.36
		50	0	23.15	22.94	23.12
	16QAM	1	0	23.65	22.58	23.54
		1	25	23.64	23.41	23.73
		1	49	22.83	23.21	23.35
		25	0	21.96	21.59	22.06
		25	13	21.97	21.69	21.80
		25	25	21.84	21.86	21.90
		50	0	21.82	21.71	21.89
Bandwidth	Modulation	RB size	RB offset	Channel	Channel	Channel
				132047/1717.5	132322/1745	132597/1772.5
15MHz	QPSK	1	0	23.99	24.18	24.00
		1	38	24.47	24.34	24.42



Bandwidth	Modulation	RB size	RB offset	Channel	Channel	Channel	
				132072/1720	132322/1745	132572/1770	
		1	74	24.03	23.87	23.95	
		36	0	23.46	22.96	23.35	
		36	18	23.33	22.91	23.04	
		36	39	23.17	22.97	23.32	
		75	0	23.13	22.90	23.07	
	16QAM	1	0	23.60	22.56	23.52	
		1	38	23.62	23.38	23.71	
		1	74	22.80	23.17	23.32	
		36	0	21.93	21.57	22.03	
		36	18	21.94	21.64	21.76	
		36	39	21.82	21.82	21.87	
		75	0	21.79	21.66	21.85	
	20MHz	QPSK	1	0	23.96	24.14	23.97
			1	50	24.46	24.30	24.40
1			99	24.01	23.86	23.92	
50			0	23.43	22.91	23.31	
50			25	23.31	22.87	23.01	
50			50	23.14	22.92	23.28	
100			0	23.10	22.85	23.03	
16QAM		1	0	23.12	22.52	23.47	
		1	50	23.58	23.36	23.67	
		1	99	22.78	23.14	23.30	
		50	0	21.90	21.53	22.00	
		50	25	21.91	21.62	21.73	
		50	50	21.79	21.77	21.83	
		100	0	21.77	21.62	21.82	

LTE Band 71				Conducted Power(dBm)		
Bandwidth	Modulation	RB size	RB offset	Channel/Frequency (MHz)		
				133147/665.5	133297/680.5	133447/695.5
5MHz	QPSK	1	0	24.12	24.38	23.92
		1	13	24.18	24.29	23.95
		1	24	23.91	23.89	23.90
		12	0	24.09	24.09	23.88
		12	6	24.07	23.95	23.92
		12	13	23.95	23.84	24.02
		25	0	22.98	22.99	22.97
	16QAM	1	0	23.10	23.07	23.43
		1	13	23.08	23.03	23.18
		1	24	22.67	22.61	23.82
		12	0	23.17	23.07	22.84



Bandwidth	Modulation	RB size	RB offset	Channel	Channel	Channel
				133172/668	133297/680.5	133422/693
		12	6	22.99	22.97	23.01
		12	13	22.95	22.89	23.04
		25	0	22.03	21.89	22.11
Bandwidth	Modulation	RB size	RB offset	Channel	Channel	Channel
				133172/668	133297/680.5	133422/693
10MHz	QPSK	1	0	23.63	23.91	23.44
		1	25	23.67	23.83	23.50
		1	49	23.43	23.43	23.43
		25	0	22.69	22.71	22.51
		25	13	22.70	22.56	22.53
		25	25	22.55	22.47	22.63
		50	0	22.52	22.54	22.52
	16QAM	1	0	22.62	22.58	22.95
		1	25	22.61	22.55	22.72
		1	49	22.19	22.15	23.34
		25	0	21.79	21.71	21.47
		25	13	21.59	21.59	21.62
		25	25	21.55	21.51	21.67
		50	0	21.57	21.44	21.63
Bandwidth	Modulation	RB size	RB offset	Channel	Channel	Channel
				133197/670.5	133297/680.5	133397/690.5
15MHz	QPSK	1	0	23.62	23.87	23.42
		1	38	23.65	23.82	23.47
		1	74	23.40	23.38	23.39
		36	0	22.67	22.67	22.48
		36	18	22.67	22.51	22.49
		36	39	22.52	22.44	22.59
		75	0	22.50	22.50	22.47
	16QAM	1	0	22.57	22.56	22.93
		1	38	22.59	22.52	22.70
		1	74	22.16	22.11	23.31
		36	0	21.76	21.69	21.44
		36	18	21.56	21.54	21.58
		36	39	21.53	21.47	21.64
		75	0	21.54	21.39	21.59
Bandwidth	Modulation	RB size	RB offset	Channel	Channel	Channel
				133222/673	133322/683	133372/688
20MHz	QPSK	1	0	24.09	24.33	23.89
		1	50	24.14	24.28	23.95
		1	99	23.88	23.87	23.86



		50	0	23.14	23.12	22.94
		50	25	23.15	22.97	22.96
		50	50	22.99	22.89	23.05
		100	0	22.97	22.95	22.93
	16QAM	1	0	23.51	23.02	23.38
		1	50	23.05	23.00	23.16
		1	99	22.64	22.58	23.79
		50	0	22.23	22.15	21.91
		50	25	22.03	22.02	22.05
		50	50	22.00	21.92	22.10
		100	0	22.02	21.85	22.06

5.2 Effective Isotropic Radiated Power

Ambient condition

Temperature	Relative humidity	Pressure
23°C ~25°C	45%~50%	101.5kPa

Methods of Measurement

1. The testing follows FCC KDB 971168 D01 v03r01 Section 5.8 and ANSI C63.26 (2015).

- a) Connect the equipment as illustrated. Mount the equipment with the manufacturer specified antenna in a vertical orientation on a manufacturer specified mounting surface located on a non-conducting rotating platform of a RF anechoic chamber (preferred) or a standard radiation site.
- b) Key the transmitter, then rotate the EUT 360° azimuthally and record spectrum analyzer power level (LVL) measurements at angular increments that are sufficiently small to permit resolution of all peaks. If a standard radiation test site is used, raise and lower the test antenna to obtain a maximum reading at each angular increment. (Note: several batteries may be needed to offset the effect of battery voltage droop, which should not exceed 5% of the manufactured specified battery voltage during transmission).
- c) Replace the transmitter under test with a vertically polarized half-wave dipole (or an antenna whose gain is known relative to an ideal half-wave dipole). The center of the antenna should be at the same location as the center of the antenna under test.
- d) Connect the antenna to a signal generator with a known output power and record the path loss (in dB) as LOSS. If a standard radiation test site is used, raise and lower the test antenna to obtain a maximum reading. $LOSS = \text{Generator Output Power (dBm)} - \text{Analyzer reading (dBm)}$
- e) Determine the effective radiated output power at each angular position from the readings in steps b) and d) using the following equation: $ERP \text{ (dBm)} = \text{LVL (dBm)} + \text{LOSS (dB)}$
- f) The maximum ERP is the maximum value determined in the preceding step.
- g) When calculating ERP, in addition to knowing the antenna radiation and matching characteristics, it is necessary to know the loss values of all elements (e.g. transmission line attenuation, mismatches, filters, combiners) interposed between the point where transmitter output power is measured, and the point where power is applied to the antenna. ERP can then be calculated as follows:
 $EIRP \text{ (dBm)} = \text{Output Power (dBm)} - \text{Losses (dB)} + \text{Antenna Gain (dBi)}$
 where: dBd refers to gain relative to an ideal dipole.
 $EIRP \text{ (dBm)} = ERP \text{ (dBm)} + 2.15 \text{ (dB.)}$

The RB allocation refers to section 5.1, using the maximum output power configuration.

Test setup

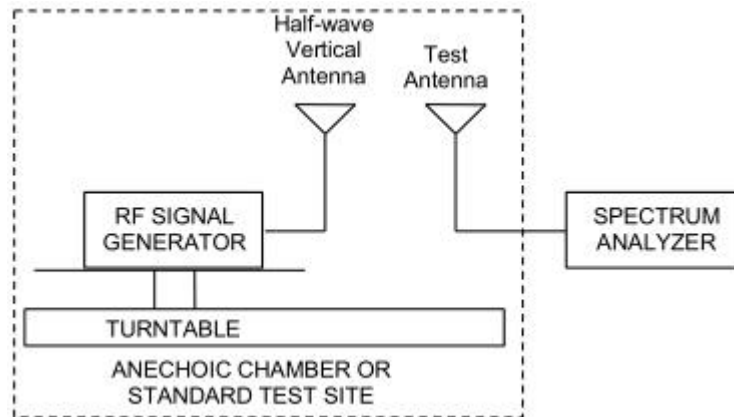
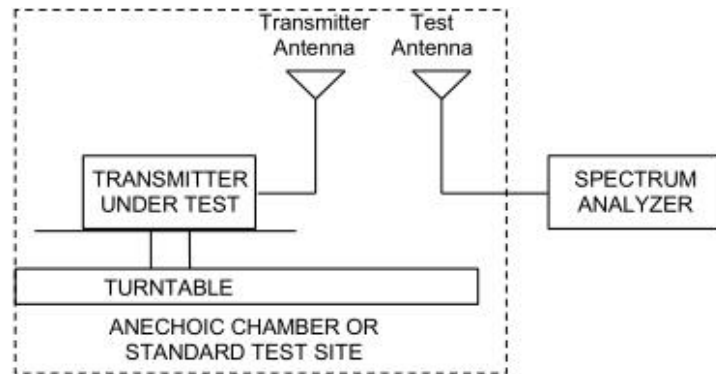

Note: Area side:2.4mX3.6m

The radiated emission was measured in the following position: EUT stand-up position (Z axis), lie-down position (X, Y axis). The worst emission was found in stand-up position (Z axis) and the worst case was recorded.

Limits

Rule Part 27.50(b) (10) specifies that “Portable stations (hand-held devices) transmitting in the 746-757 MHz, 776-788 MHz, and 805-806 MHz bands are limited to 3 watts ERP”

Rule Part 27.50(c) (10) specifies that “Portable stations (hand-held devices) in the 600 MHz uplink band and the 698-746 MHz band, and fixed and mobile stations in the 600 MHz uplink band are limited to 3 watts ERP”

Rule Part 27.50(d) (4) specifies that “Fixed, mobile and portable (hand-held) stations operating in the 1710–1755 MHz band are limited to 1 watt EIRP”

Rule Part 27.50(h) (2) specifies that “Mobile and other user stations. Mobile stations are limited to 2.0 watts EIRP. All user stations are limited to 2.0 watts transmitter output power.”

Rule Part 27.50(a) (3) specifies that “(i) For mobile and portable stations transmitting in the 2305-2315 MHz band or the 2350-2360 MHz band, the average EIRP must not exceed 50 milliwatts within any 1 megahertz of authorized bandwidth, except that for mobile and portable stations compliant with 3GPP LTE standards or another advanced mobile broadband protocol that avoids concentrating energy at the edge of the operating band the average EIRP must not exceed 250 milliwatts within any 5 megahertz of authorized bandwidth but may exceed 50 milliwatts within any 1 megahertz of authorized bandwidth. ”

Part 27.50(c)(10)Limit -LTE 12/71	$\leq 3 \text{ W}$ (34.77 dBm)
Part 27.50(d)(4)Limit -LTE 4/66	$\leq 1 \text{ W}$ (30 dBm)

Measurement Uncertainty

The assessed measurement uncertainty to ensure 95% confidence level for the normal distribution is with the coverage factor $k = 2$, $U = 1.19 \text{ dB}$

**Test Results**

The measurement is performed for both of horizontal and vertical antenna Polarization, and only the data of worst mode is recorded in this report.

Mode	Channel	Frequency (MHz)	Polarization	EIRP (dBm)	Limit (dBm)	Conclusion
WCDMA Band IV	Low	1712.4	Horizontal	28.49	30	Pass
	Mid	1732.6	Horizontal	28.46	30	Pass
	High	1752.6	Horizontal	28.21	30	Pass

LTE Band 4						
Bandwidth	Channel	Frequency (MHz)	Polarization	EIRP (dBm)	Limit (dBm)	Conclusion
1.4 MHz (QPSK)	Low	1710.7	Horizontal	29.57	30	Pass
	Mid	1732.5	Horizontal	29.66	30	Pass
	High	1754.3	Horizontal	29.59	30	Pass
3 MHz (QPSK)	Low	1711.5	Horizontal	29.92	30	Pass
	Mid	1732.5	Horizontal	29.62	30	Pass
	High	1753.5	Horizontal	29.60	30	Pass
5 MHz (QPSK)	Low	1712.5	Horizontal	29.77	30	Pass
	Mid	1732.5	Horizontal	29.56	30	Pass
	High	1752.5	Horizontal	29.98	30	Pass
10 MHz (QPSK)	Low	1715	Horizontal	29.84	30	Pass
	Mid	1732.5	Horizontal	29.70	30	Pass
	High	1750	Horizontal	29.79	30	Pass
15 MHz (QPSK)	Low	1717.5	Horizontal	29.78	30	Pass
	Mid	1732.5	Horizontal	29.70	30	Pass
	High	1747.5	Horizontal	29.73	30	Pass
20 MHz (QPSK)	Low	1720	Horizontal	29.45	30	Pass
	Mid	1732.5	Horizontal	29.76	30	Pass
	High	1745	Horizontal	29.71	30	Pass
1.4 MHz (16QAM)	Low	1710.7	Horizontal	29.05	30	Pass
	Mid	1732.5	Horizontal	29.07	30	Pass
	High	1754.3	Horizontal	29.13	30	Pass
3 MHz (16QAM)	Low	1711.5	Horizontal	29.48	30	Pass
	Mid	1732.5	Horizontal	29.15	30	Pass
	High	1753.5	Horizontal	29.08	30	Pass
5 MHz (16QAM)	Low	1712.5	Horizontal	29.22	30	Pass
	Mid	1732.5	Horizontal	29.09	30	Pass
	High	1752.5	Horizontal	29.38	30	Pass
10 MHz (16QAM)	Low	1715	Horizontal	29.40	30	Pass
	Mid	1732.5	Horizontal	29.12	30	Pass
	High	1750	Horizontal	29.36	30	Pass
15 MHz	Low	1717.5	Horizontal	29.38	30	Pass



(16QAM)	Mid	1732.5	Horizontal	29.29	30	Pass
	High	1747.5	Horizontal	29.30	30	Pass
20 MHz (16QAM)	Low	1720	Horizontal	28.95	30	Pass
	Mid	1732.5	Horizontal	29.26	30	Pass
	High	1745	Horizontal	29.21	30	Pass

LTE Band 12						
Bandwidth	Channel	Frequency (MHz)	Polarization	ERP (dBm)	Limit (dBm)	Conclusion
1.4 MHz (QPSK)	Low	699.7	Horizontal	28.86	34.77	Pass
	Mid	707.5	Horizontal	29.48	34.77	Pass
	High	715.3	Horizontal	30.26	34.77	Pass
3 MHz (QPSK)	Low	700.5	Horizontal	29.24	34.77	Pass
	Mid	707.5	Horizontal	29.43	34.77	Pass
	High	714.5	Horizontal	29.65	34.77	Pass
5 MHz (QPSK)	Low	701.5	Horizontal	29.23	34.77	Pass
	Mid	707.5	Horizontal	29.41	34.77	Pass
	High	713.5	Horizontal	29.65	34.77	Pass
10 MHz (QPSK)	Low	704	Horizontal	29.37	34.77	Pass
	Mid	707.5	Horizontal	29.42	34.77	Pass
	High	711	Horizontal	29.36	34.77	Pass
1.4 MHz (16QAM)	Low	699.7	Horizontal	28.32	34.77	Pass
	Mid	707.5	Horizontal	28.90	34.77	Pass
	High	715.3	Horizontal	29.73	34.77	Pass
3 MHz (16QAM)	Low	700.5	Horizontal	28.72	34.77	Pass
	Mid	707.5	Horizontal	28.91	34.77	Pass
	High	714.5	Horizontal	29.08	34.77	Pass
5 MHz (16QAM)	Low	701.5	Horizontal	28.73	34.77	Pass
	Mid	707.5	Horizontal	28.88	34.77	Pass
	High	713.5	Horizontal	29.17	34.77	Pass
10 MHz (16QAM)	Low	704	Horizontal	28.88	34.77	Pass
	Mid	707.5	Horizontal	28.90	34.77	Pass
	High	711	Horizontal	28.84	34.77	Pass

LTE Band 66						
Band width	Channel	Frequency (MHz)	Polarization	EIRP (dBm)	Limit (dBm)	Conclusion
1.4 MHz (QPSK)	Low	1710.70	Horizontal	29.66	30	Pass
	Mid	1745.00	Horizontal	29.73	30	Pass
	High	1779.30	Horizontal	29.86	30	Pass
3 MHz (QPSK)	Low	1711.50	Horizontal	29.67	30	Pass
	Mid	1745.00	Horizontal	29.79	30	Pass
	High	1778.50	Horizontal	29.59	30	Pass
5 MHz (QPSK)	Low	1712.50	Horizontal	29.63	30	Pass
	Mid	1745.00	Horizontal	29.65	30	Pass
	High	1777.50	Horizontal	29.78	30	Pass
10 MHz (QPSK)	Low	1715.00	Horizontal	29.86	30	Pass
	Mid	1745.00	Horizontal	29.84	30	Pass
	High	1775.00	Horizontal	29.58	30	Pass
15 MHz (QPSK)	Low	1717.50	Horizontal	29.73	30	Pass
	Mid	1745.00	Horizontal	29.75	30	Pass
	High	1772.50	Horizontal	29.46	30	Pass
20 MHz (QPSK)	Low	1720.00	Horizontal	29.54	30	Pass
	Mid	1745.00	Horizontal	29.88	30	Pass
	High	1770.00	Horizontal	29.45	30	Pass
1.4 MHz (16QAM)	Low	1710.70	Horizontal	29.17	30	Pass
	Mid	1745.00	Horizontal	29.30	30	Pass
	High	1779.30	Horizontal	29.37	30	Pass
3 MHz (16QAM)	Low	1711.50	Horizontal	29.24	30	Pass
	Mid	1745.00	Horizontal	29.28	30	Pass
	High	1778.50	Horizontal	29.05	30	Pass
5 MHz (16QAM)	Low	1712.50	Horizontal	29.06	30	Pass
	Mid	1745.00	Horizontal	29.16	30	Pass
	High	1777.50	Horizontal	29.25	30	Pass
10 MHz (16QAM)	Low	1715.00	Horizontal	29.33	30	Pass
	Mid	1745.00	Horizontal	29.37	30	Pass
	High	1775.00	Horizontal	29.12	30	Pass
15 MHz (16QAM)	Low	1717.50	Horizontal	29.15	30	Pass
	Mid	1745.00	Horizontal	29.24	30	Pass
	High	1772.50	Horizontal	28.89	30	Pass
20 MHz (16QAM)	Low	1720.00	Horizontal	29.13	30	Pass
	Mid	1745.00	Horizontal	29.45	30	Pass
	High	1770.00	Horizontal	29.01	30	Pass



LTE Band 71						
Bandwidth	Channel	Frequency (MHz)	Polarization	ERP (dBm)	Limit (dBm)	Conclusion
5 MHz (QPSK)	Low	665.5	Horizontal	29.50	34.77	Pass
	Mid	680.5	Horizontal	29.38	34.77	Pass
	High	695.5	Horizontal	28.77	34.77	Pass
10 MHz (QPSK)	Low	668	Horizontal	29.39	34.77	Pass
	Mid	680.5	Horizontal	29.35	34.77	Pass
	High	693	Horizontal	28.94	34.77	Pass
15 MHz (QPSK)	Low	670.5	Horizontal	29.22	34.77	Pass
	Mid	680.5	Horizontal	29.25	34.77	Pass
	High	690.5	Horizontal	28.98	34.77	Pass
20 MHz (QPSK)	Low	673	Horizontal	29.09	34.77	Pass
	Mid	683	Horizontal	29.23	34.77	Pass
	High	688	Horizontal	28.87	34.77	Pass
5 MHz (16QAM)	Low	665.5	Horizontal	29.00	34.77	Pass
	Mid	680.5	Horizontal	28.78	34.77	Pass
	High	695.5	Horizontal	28.23	34.77	Pass
10 MHz (16QAM)	Low	668	Horizontal	28.92	34.77	Pass
	Mid	680.5	Horizontal	28.93	34.77	Pass
	High	693	Horizontal	28.53	34.77	Pass
15 MHz (16QAM)	Low	670.5	Horizontal	28.77	34.77	Pass
	Mid	680.5	Horizontal	28.76	34.77	Pass
	High	690.5	Horizontal	28.38	34.77	Pass
20 MHz (16QAM)	Low	673	Horizontal	28.61	34.77	Pass
	Mid	683	Horizontal	28.68	34.77	Pass
	High	688	Horizontal	28.41	34.77	Pass



5.3 Radiates Spurious Emission

Ambient condition

Temperature	Relative humidity	Pressure
23°C ~25°C	45%~50%	101.5kPa

Method of Measurement

- The testing follows FCC KDB 971168 D01 v03r01 Section 5.8 and ANSI C63.26 (2015).
- Below 1GHz: The EUT is placed on a turntable 0.8 meters above the ground in the chamber, 3 meter away from the antenna. The maximal emission value is acquired by adjusting the antenna height, polarisation and turntable azimuth. Normally, the height range of antenna is 1 m to 4 m, the azimuth range of turntable is 0° to 360°, and the receive antenna has two polarizations Vertical (V) and Horizontal (H). Above 1GHz: (Note: the FCC's permission to use 1.5m as an alternative per TCBC Conf call of Dec. 2, 2014.) The EUT is placed on a turntable 1.5 meters above the ground in the chamber, 3 meter away from the antenna. The maximal emission value is acquired by adjusting the antenna height, polarisation and turntable azimuth. Normally, the height range of antenna is 1 m to 4 m, the azimuth range of turntable is 0° to 360°, and the receive antenna has two polarizations Vertical (V) and Horizontal (H).
- A loop antenna, A log-periodic antenna or horn antenna shall be substituted in place of the EUT. The log-periodic antenna will be driven by a signal generator and the level will be adjusted till the same power value on the spectrum analyzer or receiver. The level of the spurious emissions can be calculated through the level of the signal generator, cable loss, the gain of the substitution antenna and the reading of the spectrum analyzer or receiver.
- The EUT is then put into continuously transmitting mode at its maximum power level during the test. Set Test Receiver or Spectrum RBW=200Hz,VBW=600Hz for 9kHz150kHz , RBW=10kHz, VBW=30kHz 150kHz-30MHz ,RBW=100kHz,VBW=300kHz for 30MHz to 1GHz and RBW=1MHz, VBW=3MHz for above 1GHz And the maximum value of the receiver should be recorded as (Pr).
- The EUT shall be replaced by a substitution antenna. In the chamber, an substitution antenna for the frequency band of interest is placed at the reference point of the chamber. An RF Signal source for the frequency band of interest is connected to the substitution antenna with a cable that has been constructed to not interfere with the radiation pattern of the antenna. A power (PMea) is applied to the input of the substitution antenna, and adjust the level of the signal generator output until the value of the receiver reach the previously recorded (Pr). The power of signal source (PMea) is recorded. The test should be performed by rotating the test item and adjusting the receiving antenna polarization.
- A amplifier should be connected to the Signal Source output port. And the cable should be connect between the Amplifier and the Substitution Antenna. The cable loss (Pcl) ,the Substitution Antenna Gain (Ga) and the Amplifier Gain (PAg) should be recorded after test.
- The measurement results are obtained as described below:

$$\text{Power(EIRP)} = \text{PMea} - \text{PAg} - \text{Pcl} + \text{Ga}$$
 The measurement results are amend as described below:

$$\text{Power(EIRP)} = \text{PMea} - \text{Pcl} + \text{Ga}$$
- This value is EIRP since the measurement is calibrated using an antenna of known gain (2.15 dBi) and known input power. ERP can be calculated from EIRP by subtracting the gain of the dipole, ERP

= EIRP-2.15dBi.

The modulation mode and RB allocation refer to section 5.1, using the maximum output power configuration.

Test setup

9KHz ~ 30MHz

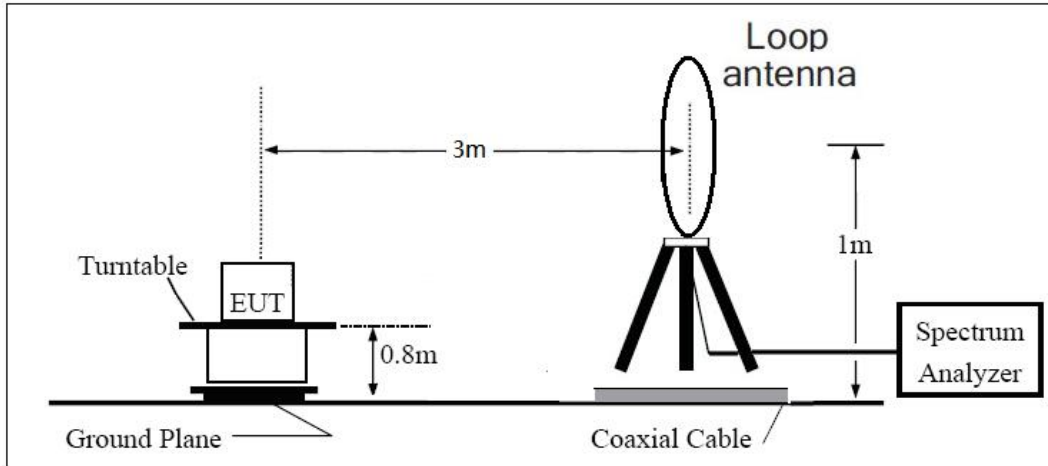

30MHz ~ 1GHz

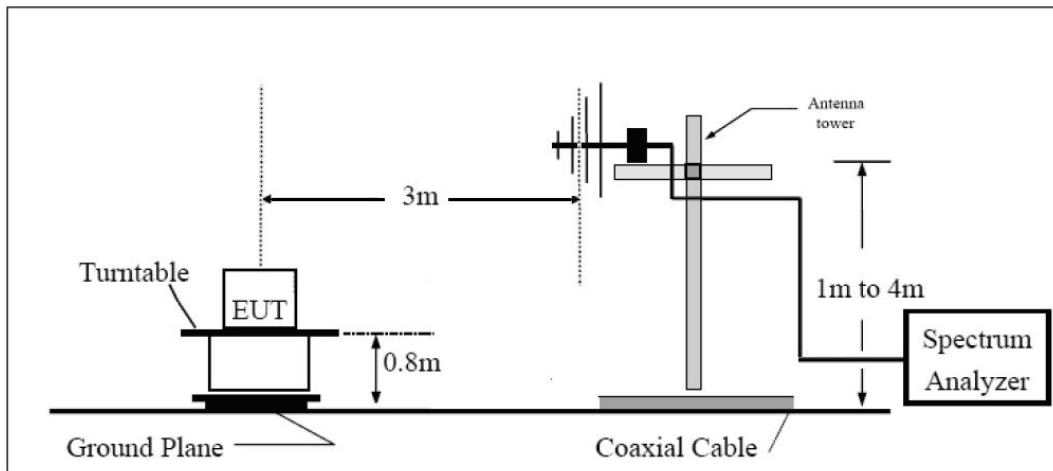

Above 1GHz

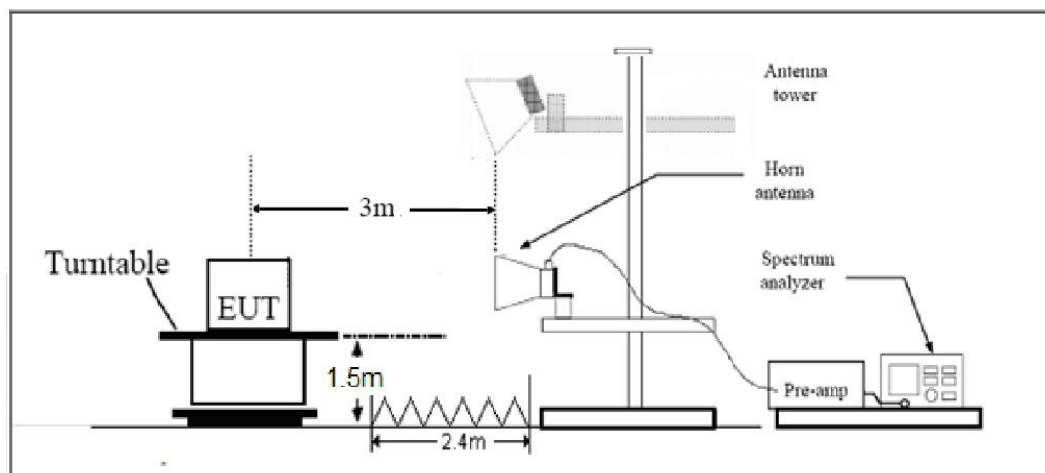

Note: Area side:2.4mX3.6m



Limits

Rule Part 27.53(h) specifies that “for operations in the 1695-1710 MHz, 1710-1755 MHz, 1755-1780 MHz, 1915-1920 MHz, 1995-2000 MHz, 2000-2020 MHz, 2110-2155 MHz, 2155-2180 MHz, and 2180-2200 bands, the power of any emission outside a licensee's frequency block shall be attenuated below the transmitter power (P) in watts by at least $43 + 10 \log_{10}(P)$ dB.”

Rule Part 27.53 (g) For operations in the 600 MHz band and the 698-746 MHz band, the power of any emission outside a licensee's frequency band(s) of operation shall be attenuated below the transmitter power (P) within the licensed band(s) of operation, measured in watts, by at least $43 + 10 \log(P)$ dB. Compliance with this provision is based on the use of measurement instrumentation employing a resolution bandwidth of 100 kilohertz or greater. However, in the 100 kilohertz bands immediately outside and adjacent to a licensee's frequency block, a resolution bandwidth of at least 30 kHz may be employed.

Part 27.53 (h)/(g) Limit

-13 dBm

Measurement Uncertainty

The assessed measurement uncertainty to ensure 95% confidence level for the normal distribution is with the coverage factor $k = \pm 1.96$, $U = \pm 3.55$ dB.

Test Result

Sweep the whole frequency band through the range from 9kHz to the 10th harmonic of the carrier, the emissions below the noise floor will not be recorded in the report.

WCDMA Band IV CH-Middle

Harmonic	Frequency (MHz)	SG (dBm)	Cable Loss (dB)	Gain (dBi)	Antenna Polarization	EIRP Level (dBm)	Limit (dBm)	Margin (dB)	Azimuth (deg)
2	3462.8	-57.70	2.6	10.75	Horizontal	-49.55	-13.00	36.55	45
3	5201.3	-53.18	2.4	11.05	Horizontal	-44.53	-13.00	31.53	225
4	6925.1	-59.30	4.5	11.15	Horizontal	-52.65	-13.00	39.65	45
5	8663.0	-53.45	5.1	11.35	Horizontal	-47.20	-13.00	34.20	0
6	10395.6	-50.38	5.3	11.95	Horizontal	-43.73	-13.00	30.73	270
7	12128.2	-51.35	5.5	13.55	Horizontal	-43.30	-13.00	30.30	225
8	13860.8	-49.19	6.3	13.75	Horizontal	-41.74	-13.00	28.74	270
9	15593.4	-49.57	6.7	13.85	Horizontal	-42.42	-13.00	29.42	315
10	17326.0	-47.18	6.8	14.25	Horizontal	-39.73	-13.00	26.73	90

Note: 1.The other Spurious RF Radiated emissions level is no more than noise floor.
2. The worst emission was found in the antenna is Horizontal position.

LTE Band 4 QPSK 1.4MHz CH-Middle, RB 1

Harmonic	Frequency (MHz)	SG (dBm)	Cable Loss (dB)	Gain (dBi)	Antenna Polarization	EIRP Level (dBm)	Limit (dBm)	Margin (dB)	Azimuth (deg)
2	3464.3	-53.63	2.6	10.75	Horizontal	-45.48	-13.00	32.48	135
3	5197.5	-48.91	2.4	11.05	Horizontal	-40.26	-13.00	27.26	45
4	6930.0	-54.65	4.5	11.15	Horizontal	-48.00	-13.00	35.00	225
5	8662.5	-53.89	5.1	11.35	Horizontal	-47.64	-13.00	34.64	270
6	10395.0	-50.20	5.3	11.95	Horizontal	-43.55	-13.00	30.55	135
7	12127.5	-51.88	5.5	13.55	Horizontal	-43.83	-13.00	30.83	45
8	13860.0	-51.54	6.3	13.75	Horizontal	-44.09	-13.00	31.09	180
9	15592.5	-50.44	6.7	13.85	Horizontal	-43.29	-13.00	30.29	90
10	17325.0	-51.51	6.8	14.25	Horizontal	-44.06	-13.00	31.06	0

Note: 1.The other Spurious RF Radiated emissions level is no more than noise floor.
2. The worst emission was found in the antenna is Horizontal position.



LTE Band 4 QPSK 5MHz CH-Middle, RB 1

Harmonic	Frequency (MHz)	SG (dBm)	Cable Loss (dB)	Gain (dBi)	Antenna Polarization	EIRP Level (dBm)	Limit (dBm)	Margin (dB)	Azimuth (deg)
2	3460.5	-53.93	2.6	10.75	Horizontal	-45.78	-13.00	32.78	135
3	5191.5	-49.50	2.4	11.05	Horizontal	-40.85	-13.00	27.85	45
4	6930.0	-53.94	4.5	11.15	Horizontal	-47.29	-13.00	34.29	0
5	8662.5	-52.69	5.1	11.35	Horizontal	-46.44	-13.00	33.44	0
6	10395.0	-51.39	5.3	11.95	Horizontal	-44.74	-13.00	31.74	180
7	12127.5	-49.11	5.5	13.55	Horizontal	-41.06	-13.00	28.06	90
8	13860.0	-49.20	6.3	13.75	Horizontal	-41.75	-13.00	28.75	135
9	15592.5	-48.71	6.7	13.85	Horizontal	-41.56	-13.00	28.56	45
10	17325.0	-51.77	6.8	14.25	Horizontal	-44.32	-13.00	31.32	225

Note: 1.The other Spurious RF Radiated emissions level is no more than noise floor.
2. The worst emission was found in the antenna is Horizontal position.

LTE Band 4 QPSK 20MHz CH-Middle, RB 1

Harmonic	Frequency (MHz)	SG (dBm)	Cable Loss (dB)	Gain (dBi)	Antenna Polarization	EIRP Level (dBm)	Limit (dBm)	Margin (dB)	Azimuth (deg)
2	3447.0	-53.65	2.6	10.75	Horizontal	-45.50	-13.00	32.50	270
3	5170.5	-50.81	2.4	11.05	Horizontal	-42.16	-13.00	29.16	135
4	6930.0	-57.94	4.5	11.15	Horizontal	-51.29	-13.00	38.29	45
5	8662.5	-55.25	5.1	11.35	Horizontal	-49.00	-13.00	36.00	0
6	10395.0	-50.14	5.3	11.95	Horizontal	-43.49	-13.00	30.49	90
7	12127.5	-52.02	5.5	13.55	Horizontal	-43.97	-13.00	30.97	180
8	13860.0	-52.26	6.3	13.75	Horizontal	-44.81	-13.00	31.81	0
9	15592.5	-49.72	6.7	13.85	Horizontal	-42.57	-13.00	29.57	135
10	17325.0	-51.58	6.8	14.25	Horizontal	-44.13	-13.00	31.13	45

Note: 1.The other Spurious RF Radiated emissions level is no more than noise floor.
2. The worst emission was found in the antenna is Horizontal position.



LTE Band 12 QPSK 1.4MHz CH-Middle, RB 1

Harmonic	Frequency (MHz)	SG (dBm)	Cable Loss (dB)	Gain (dBi)	Antenna Polarization	ERP Level (dBm)	Limit (dBm)	Margin (dB)	Azimuth (deg)
2	1415.00	-63.89	2.00	10.75	Horizontal	-57.29	-13.00	44.29	135
3	2122.50	-54.46	2.51	11.05	Horizontal	-48.07	-13.00	35.07	45
4	2830.00	-63.52	4.20	11.15	Horizontal	-58.72	-13.00	45.72	0
5	3537.50	-62.63	5.20	11.15	Horizontal	-58.83	-13.00	45.83	90
6	4245.00	-61.63	5.50	11.95	Horizontal	-57.33	-13.00	44.33	315
7	4952.50	-61.65	5.70	13.55	Horizontal	-55.95	-13.00	42.95	180
8	5660.00	-59.23	6.30	13.75	Horizontal	-53.93	-13.00	40.93	45
9	6367.50	-59.51	6.80	13.85	Horizontal	-54.61	-13.00	41.61	135
10	7075.00	-57.68	6.90	14.25	Horizontal	-52.48	-13.00	39.48	0

Note: 1.The other Spurious RF Radiated emissions level is no more than noise floor.
2. The worst emission was found in the antenna is Horizontal position.

LTE Band 12 QPSK 5MHz CH-Middle, RB 1

Harmonic	Frequency (MHz)	SG (dBm)	Cable Loss (dB)	Gain (dBi)	Antenna Polarization	ERP Level (dBm)	Limit (dBm)	Margin (dB)	Azimuth (deg)
2	1415.00	-65.06	2.00	10.75	Horizontal	-58.46	-13.00	45.46	225
3	2122.50	-59.61	2.51	11.05	Horizontal	-53.22	-13.00	40.22	0
4	2830.00	-62.96	4.20	11.15	Horizontal	-58.16	-13.00	45.16	270
5	3537.50	-63.19	5.20	11.15	Horizontal	-59.39	-13.00	46.39	180
6	4245.00	-61.31	5.50	11.95	Horizontal	-57.01	-13.00	44.01	90
7	4952.50	-61.69	5.70	13.55	Horizontal	-55.99	-13.00	42.99	45
8	5660.00	-59.74	6.30	13.75	Horizontal	-54.44	-13.00	41.44	135
9	6367.50	-58.82	6.80	13.85	Horizontal	-53.92	-13.00	40.92	0
10	7075.00	-55.13	6.90	14.25	Horizontal	-49.93	-13.00	36.93	135

Note: 1.The other Spurious RF Radiated emissions level is no more than noise floor.
2. The worst emission was found in the antenna is Horizontal position.



LTE Band 12 QPSK 10MHz CH-Middle, RB 1

Harmonic	Frequency (MHz)	SG (dBm)	Cable Loss (dB)	Gain (dBi)	Antenna Polarization	ERP Level (dBm)	Limit (dBm)	Margin (dB)	Azimuth (deg)
2	1415.00	-66.91	2.00	10.75	Horizontal	-60.31	-13.00	47.31	135
3	2122.50	-62.01	2.51	11.05	Horizontal	-55.62	-13.00	42.62	45
4	2830.00	-61.99	4.20	11.15	Horizontal	-57.19	-13.00	44.19	180
5	3537.50	-62.86	5.20	11.15	Horizontal	-59.06	-13.00	46.06	45
6	4245.00	-61.42	5.50	11.95	Horizontal	-57.12	-13.00	44.12	0
7	4952.50	-61.24	5.70	13.55	Horizontal	-55.54	-13.00	42.54	0
8	5660.00	-58.75	6.30	13.75	Horizontal	-53.45	-13.00	40.45	180
9	6367.50	-57.65	6.80	13.85	Horizontal	-52.75	-13.00	39.75	90
10	7075.00	-54.81	6.90	14.25	Horizontal	-49.61	-13.00	36.61	315

Note: 1.The other Spurious RF Radiated emissions level is no more than noise floor.
2. The worst emission was found in the antenna is Horizontal position.

LTE Band 66 QPSK 1.4MHz CH-Middle, RB 1

Harmonic	Frequency (MHz)	SG (dBm)	Cable Loss (dB)	Gain (dBi)	Antenna Polarization	EIRP Level (dBm)	Limit (dBm)	Margin (dB)	Azimuth (deg)
2	3464.3	-59.54	2.6	10.75	Horizontal	-51.39	-13.00	38.39	135
3	5197.5	-52.32	2.4	11.05	Horizontal	-43.67	-13.00	30.67	0
4	6930.0	-54.86	4.5	11.15	Horizontal	-48.21	-13.00	35.21	225
5	8662.5	-52.47	5.1	11.35	Horizontal	-46.22	-13.00	33.22	0
6	10395.0	-50.05	5.3	11.95	Horizontal	-43.40	-13.00	30.40	270
7	12127.5	-51.04	5.5	13.55	Horizontal	-42.99	-13.00	29.99	135
8	13860.0	-53.03	6.3	13.75	Horizontal	-45.58	-13.00	32.58	45
9	15592.5	-48.52	6.7	13.85	Horizontal	-41.37	-13.00	28.37	180
10	17325.0	-48.85	6.8	14.25	Horizontal	-41.40	-13.00	28.40	90

Note: 1.The other Spurious RF Radiated emissions level is no more than noise floor.
2. The worst emission was found in the antenna is Horizontal position.



LTE Band 66 QPSK 5MHz CH-Middle, RB 1

Harmonic	Frequency (MHz)	SG (dBm)	Cable Loss (dB)	Gain (dBi)	Antenna Polarization	EIRP Level (dBm)	Limit (dBm)	Margin (dB)	Azimuth (deg)
2	3460.5	-55.03	2.6	10.75	Horizontal	-46.88	-13.00	33.88	315
3	5191.5	-48.51	2.4	11.05	Horizontal	-39.86	-13.00	26.86	180
4	6930.0	-54.23	4.5	11.15	Horizontal	-47.58	-13.00	34.58	45
5	8662.5	-52.15	5.1	11.35	Horizontal	-45.90	-13.00	32.90	135
6	10395.0	-49.81	5.3	11.95	Horizontal	-43.16	-13.00	30.16	0
7	12127.5	-52.49	5.5	13.55	Horizontal	-44.44	-13.00	31.44	45
8	13860.0	-48.67	6.3	13.75	Horizontal	-41.22	-13.00	28.22	135
9	15592.5	-49.36	6.7	13.85	Horizontal	-42.21	-13.00	29.21	0
10	17325.0	-50.67	6.8	14.25	Horizontal	-43.22	-13.00	30.22	180

Note: 1.The other Spurious RF Radiated emissions level is no more than noise floor.

2. The worst emission was found in the antenna is Horizontal position.

LTE Band 66 QPSK 20MHz CH-Middle, RB 1

Harmonic	Frequency (MHz)	SG (dBm)	Cable Loss (dB)	Gain (dBi)	Antenna Polarization	EIRP Level (dBm)	Limit (dBm)	Margin (dB)	Azimuth (deg)
2	3447.0	-52.96	2.6	10.75	Horizontal	-44.81	-13.00	31.81	90
3	5170.5	-47.19	2.4	11.05	Horizontal	-38.54	-13.00	25.54	45
4	6930.0	-53.10	4.5	11.15	Horizontal	-46.45	-13.00	33.45	135
5	8662.5	-53.10	5.1	11.35	Horizontal	-46.85	-13.00	33.85	0
6	10395.0	-50.89	5.3	11.95	Horizontal	-44.24	-13.00	31.24	135
7	12127.5	-52.32	5.5	13.55	Horizontal	-44.27	-13.00	31.27	45
8	13860.0	-52.33	6.3	13.75	Horizontal	-44.88	-13.00	31.88	0
9	15592.5	-49.75	6.7	13.85	Horizontal	-42.60	-13.00	29.60	0
10	17325.0	-51.09	6.8	14.25	Horizontal	-43.64	-13.00	30.64	180

Note: 1.The other Spurious RF Radiated emissions level is no more than noise floor.

2. The worst emission was found in the antenna is Horizontal position.



LTE Band 71 QPSK 5MHz CH-Middle, RB 1

Harmonic	Frequency (MHz)	SG (dBm)	Cable Loss (dB)	Gain (dBi)	Antenna Polarization	ERP Level (dBm)	Limit (dBm)	Margin (dB)	Azimuth (deg)
2	1362.5	-66.83	2.00	10.75	Horizontal	-60.23	-13.00	47.23	135
3	2041.0	-66.19	2.51	11.05	Horizontal	-59.80	-13.00	46.80	45
4	2721.0	-63.70	4.20	11.15	Horizontal	-58.90	-13.00	45.90	180
5	3406.5	-62.80	5.20	11.15	Horizontal	-59.00	-13.00	46.00	45
6	4082.3	-59.59	5.50	11.95	Horizontal	-55.29	-13.00	42.29	135
7	4765.1	-59.46	5.70	13.55	Horizontal	-53.76	-13.00	40.76	0
8	5441.3	-57.45	6.30	13.75	Horizontal	-52.15	-13.00	39.15	180
9	6119.6	-56.42	6.80	13.85	Horizontal	-51.52	-13.00	38.52	90
10	6805.4	-53.56	6.90	14.25	Horizontal	-48.36	-13.00	35.36	45

Note: 1.The other Spurious RF Radiated emissions level is no more than noise floor.
2. The worst emission was found in the antenna is Horizontal position.

LTE Band 71 QPSK 20MHz CH-Middle, RB 1

Harmonic	Frequency (MHz)	SG (dBm)	Cable Loss (dB)	Gain (dBi)	Antenna Polarization	ERP Level (dBm)	Limit (dBm)	Margin (dB)	Azimuth (deg)
2	1347.5	-67.20	2.00	10.75	Vertical	-60.60	-13.00	47.60	90
3	2022.5	-65.93	2.51	11.05	Vertical	-59.54	-13.00	46.54	315
4	2696.5	-62.77	4.20	11.15	Vertical	-57.97	-13.00	44.97	180
5	3415.0	-61.79	5.20	11.15	Vertical	-57.99	-13.00	44.99	135
6	4098.0	-61.57	5.50	11.95	Vertical	-57.27	-13.00	44.27	0
7	4781.0	-62.18	5.70	13.55	Vertical	-56.48	-13.00	43.48	180
8	5464.0	-60.02	6.30	13.75	Vertical	-54.72	-13.00	41.72	45
9	6147.0	-56.95	6.80	13.85	Vertical	-52.05	-13.00	39.05	135
10	6830.0	-54.05	6.90	14.25	Vertical	-48.85	-13.00	35.85	0

Note: 1.The other Spurious RF Radiated emissions level is no more than noise floor.
2. The worst emission was found in the antenna is Vertical position.



6 Main Test Instruments

Name	Manufacturer	Type	Serial Number	Calibration Date	Expiration Date
Base Station Simulator	R&S	CMW500	113824	2019-05-19	2020-05-18
Power Splitter	Hua Xiang	SHX-GF2-2-13	10120101	/	/
Spectrum Analyzer	Key sight	N9010A	MY50210259	2019-05-19	2020-05-18
Signal Analyzer	R&S	FSV30	100815	2018-12-16	2019-12-15
Loop Antenna	SCHWARZBECK	FMZB1519	1519-047	2017-09-26	2019-09-25
Trilog Antenna	SCHWARZBECK	VUBL 9163	9163-201	2017-11-18	2019-11-17
Horn Antenna	R&S	HF907	100126	2018-07-07	2020-07-06
Horn Antenna	ETS-Lindgren	3160-09	00102643	2018-06-20	2020-06-19
Signal generator	R&S	SMB 100A	102594	2019-05-19	2020-05-18
Climatic Chamber	ESPEC	SU-242	93000506	2017-12-17	2020-12-16
Preamplifier	R&S	SCU18	102327	2019-05-19	2020-05-18
MOB COMMS DC SUPPLY	Keysight	66319D	MY43004105	2019-05-19	2020-05-18
RF Cable	Agilent	SMA 15cm	0001	2019-06-14	2019-09-13
Software	R&S	EMC32	9.26.0	/	/

*****END OF REPORT *****

ANNEX A: EUT Appearance and Test Setup

A.1 EUT Appearance



a: EUT

Picture 1 EUT and Accessory

A.2 Test Setup

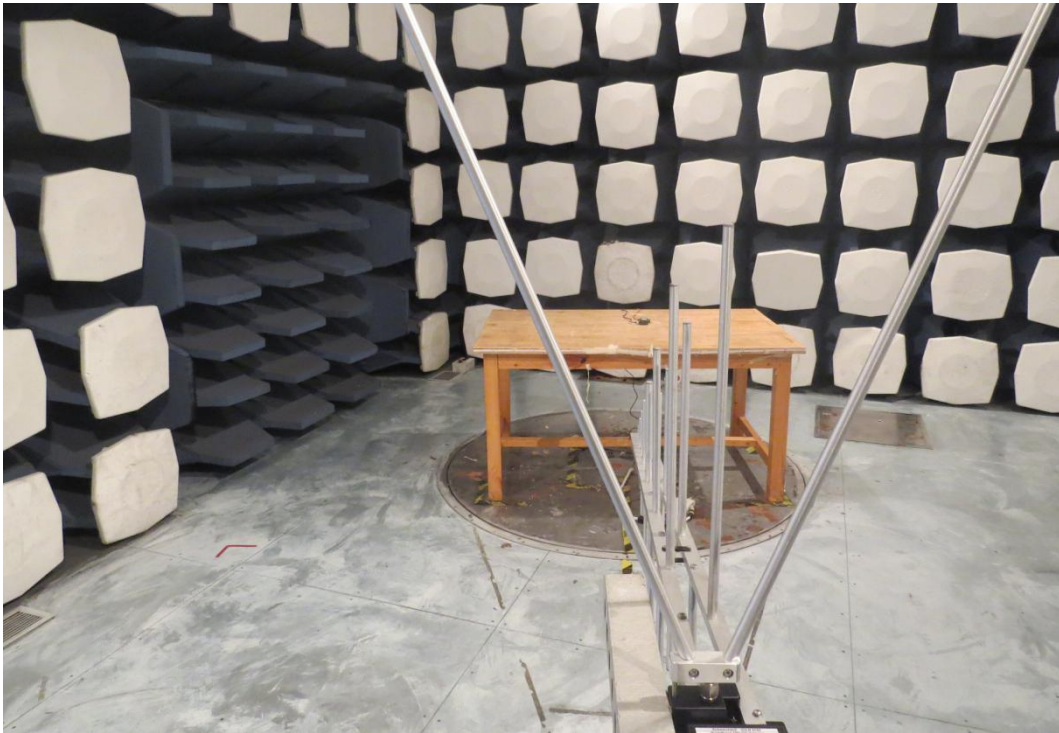

30MHz ~ 1GHz



Above 1GHz

Picture 2 Radiated Spurious Emissions Test setup