

Power

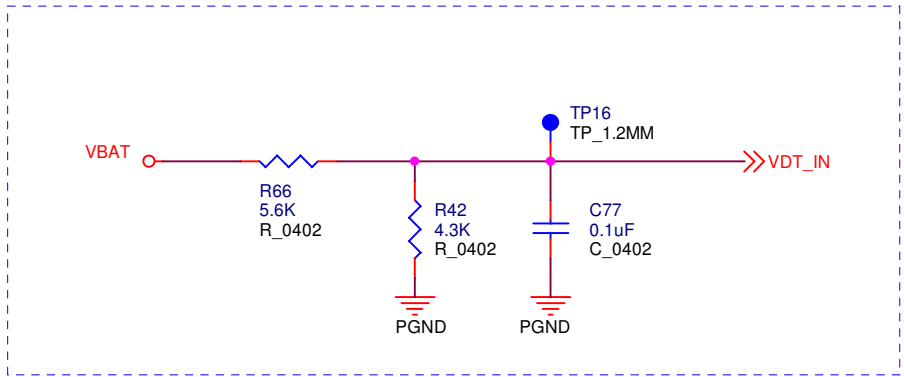
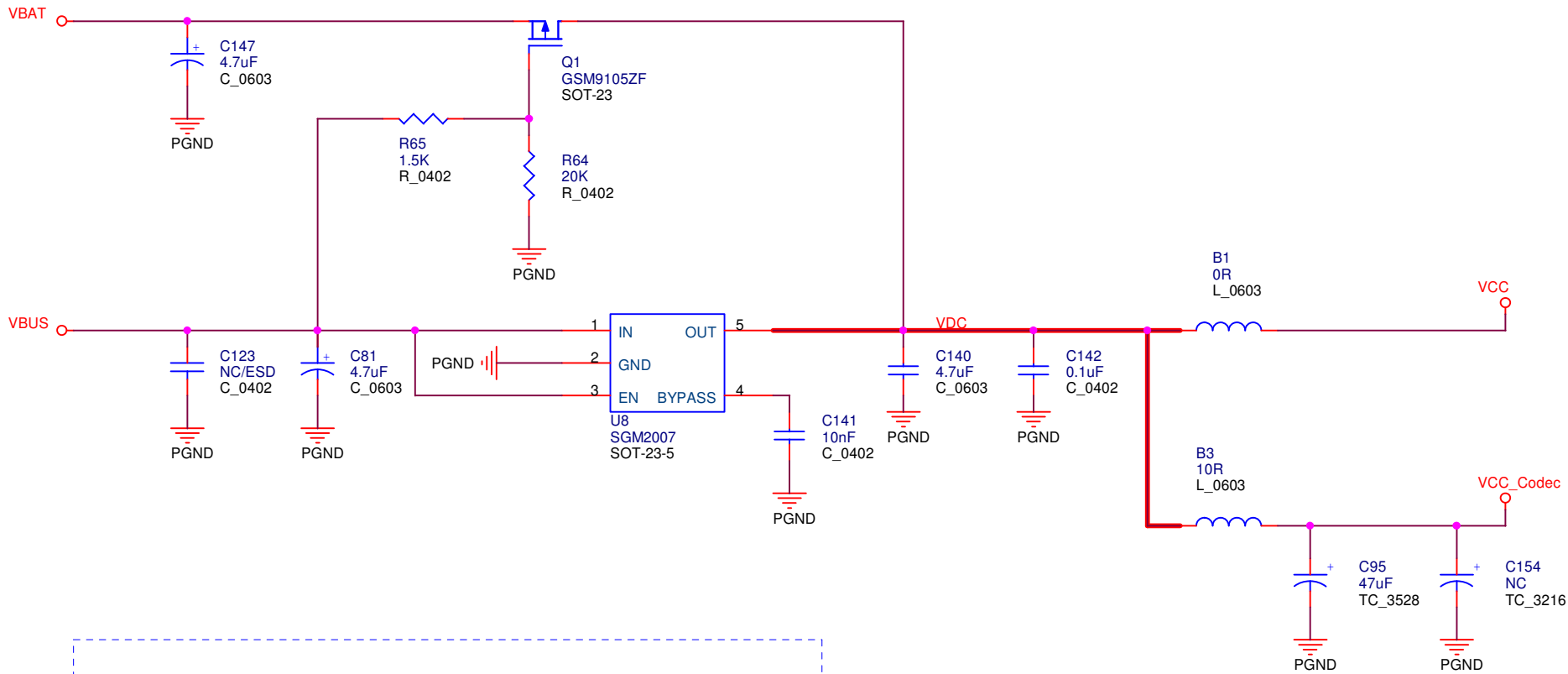

Low battery detect

Low battery detection for 3.2V

Title		
IA2EH Core Module RX		
Size	Document Number	Rev
Custom	POWER / GND	2
Date:	Tuesday, December 21, 2010	Sheet 1 of 3

CODEC

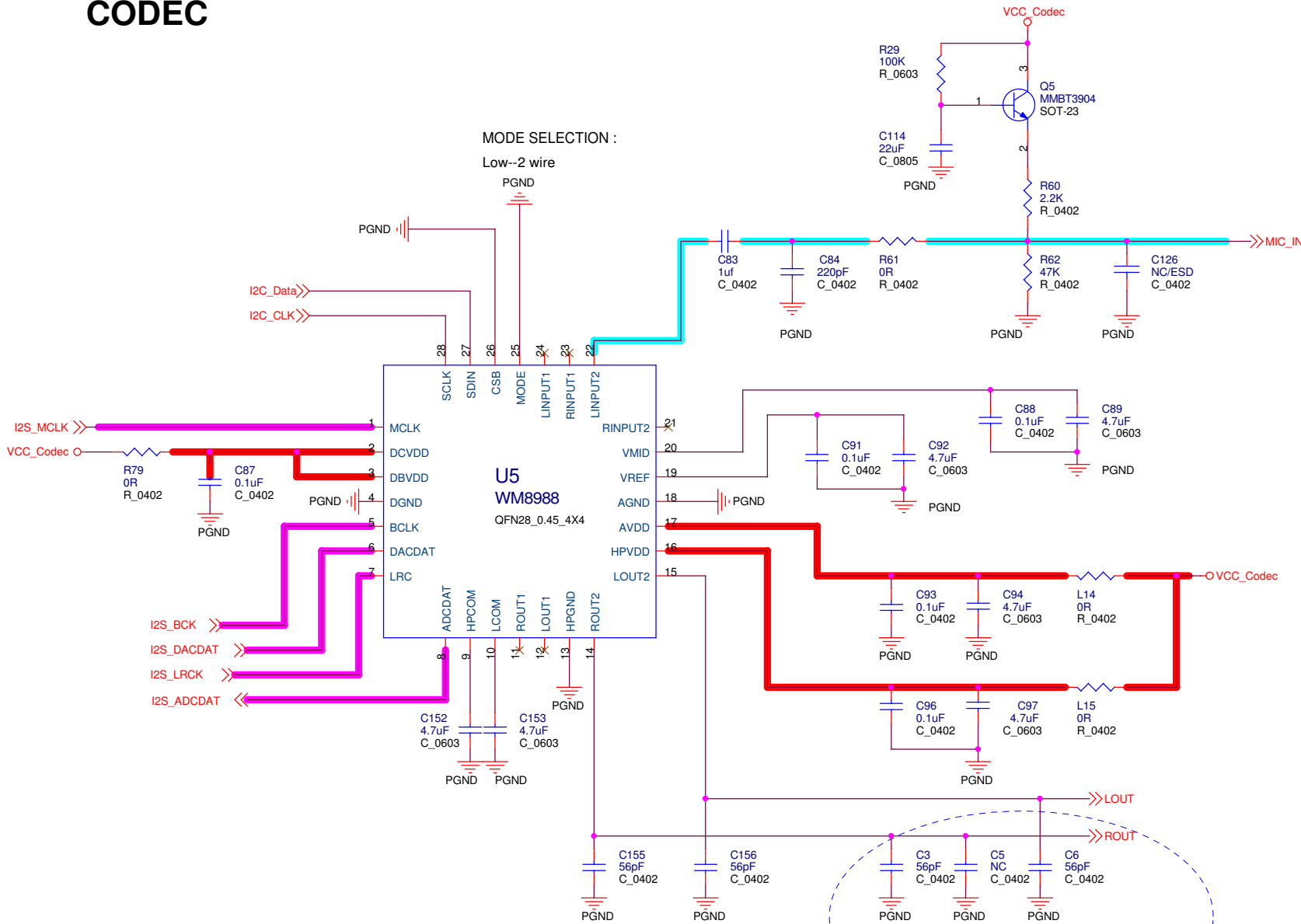

MODE SELECTION :

Low--2 wire

PGND

I2C_Data

I2C_CLK

I2S_MCLK

VCC_Codec

I2S_BCK

I2S_DACDAT

I2S_LRCK

I2S_ADCDAT

U5
WM8988

QFN28_0.45_4X4

C6 close to J1 Pin9
C3,C5 close to J1 Pin10

- Analog signal : As short as possible and surrounded by ground
- I2S signal : pallel to each other and surrounded by ground
- Power line : At least 15mil wide suggested

Title		
IA2EH Core Module RX		
Size	Document Number	Rev
Custom	WM8988	2
Date:	Tuesday, December 21, 2010	Sheet 3 of 3
		1