



FCC RF Test Report

APPLICANT : LENOVO (BEIJING) LIMITED
EQUIPMENT : Mobile Phone
BRAND NAME : Lenovo
MODEL NAME : Lenovo L70081
FCC ID : A5MLM21C81
STANDARD : 47 CFR Part 2, 22, 24, 27
CLASSIFICATION : PCS Licensed Transmitter Held to Ear (PCE)
TEST DATE(S) : Apr. 01, 2021 ~ Apr. 28, 2021

We, Sporton International (Kunshan) Inc., would like to declare that the tested sample has been evaluated in accordance with the procedures given in ANSI C63.26-2015 and shown compliance with the applicable technical standards.

The test results in this report apply exclusively to the tested model / sample. Without written approval of Sporton International (Kunshan) Inc., the test report shall not be reproduced except in full.

Jason Jia

Reviewed by: Jason Jia / Supervisor

Alex Wang

Approved by: Alex Wang / Manager



Sporton International (Kunshan) Inc.

**No. 1098, Pengxi North Road, Kunshan Economic Development Zone Jiangsu Province 215300
People's Republic of China**



TABLE OF CONTENTS

REVISION HISTORY... 3
SUMMARY OF TEST RESULT ... 4
1 GENERAL DESCRIPTION ... 5
1.1 Applicant ... 5
1.2 Manufacturer ... 5
1.3 Product Feature of Equipment Under Test ... 5
1.4 Product Specification of Equipment Under Test ... 6
1.5 Modification of EUT ... 6
1.6 Maximum ERP/EIRP Power, Frequency Tolerance, and Emission Designator ... 6
1.7 Testing Location ... 8
1.8 Test Software ... 8
1.9 Applicable Standards ... 8
2 TEST CONFIGURATION OF EQUIPMENT UNDER TEST ... 9
2.1 Test Mode ... 9
2.2 Connection Diagram of Test System ... 11
2.3 Support Unit used in test configuration and system ... 11
2.4 Measurement Results Explanation Example ... 11
2.5 Frequency List of Low/Middle/High Channels ... 12
3 CONDUCTED TEST ITEMS ... 14
3.1 Measuring Instruments ... 14
3.2 Test Setup ... 14
3.3 Test Result of Conducted Test ... 14
3.4 Conducted Output Power and ERP/EIRP ... 15
3.5 Peak-to-Average Ratio ... 16
3.6 Occupied Bandwidth ... 16
3.7 Conducted Band Edge ... 18
3.8 Conducted Spurious Emission ... 20
3.9 Frequency Stability ... 21
4 RADIATED TEST ITEMS ... 22
4.1 Measuring Instruments ... 22
4.2 Test Setup ... 22
4.3 Test Result of Radiated Test ... 22
4.4 Radiated Spurious Emission ... 23
5 LIST OF MEASURING EQUIPMENT ... 24
6 UNCERTAINTY OF EVALUATION ... 25
APPENDIX A. TEST RESULTS OF CONDUCTED TEST
APPENDIX B. TEST RESULTS OF RADIATED TEST
APPENDIX C. TEST SETUP PHOTOGRAPHS



REVISION HISTORY

REPORT NO.	VERSION	DESCRIPTION	ISSUED DATE
FG111226-01D	Rev. 01	Initial issue of report	Jun. 08, 2021



SUMMARY OF TEST RESULT

Report Section	FCC Rule	Description	Limit	Result	Remark
3.4	§2.1046	Conducted Output Power	Reporting Only	PASS	-
	§22.913(a)(5)	Effective Radiated Power (5G NR n5)	ERP < 7 Watt		
	§27.50(c)(10)	Effective Radiated Power (5G NR n71)	ERP < 3 Watt		
	§24.232(c)	Equivalent Isotropic Radiated Power (5G NR n2, n25)	EIRP < 2Watt		
	§27.50(d)(4)	Equivalent Isotropic Radiated Power (5G NR n66)	EIRP < 1Watt		
3.5	§24.232(d) §27.50(j)(4)	Peak-to-Average Ratio	<13 dB	PASS	-
3.6	§2.1049	Occupied Bandwidth	Reporting Only	PASS	-
3.7	§2.1051 §22.917(a) §24.238(a) §27.53(h) §27.53(g)	Conducted Band Edge Measurement (5G NR n5) (5G NR n2, n25) (5G NR n66) (5G NR n71)	< 43+10log10(P[Watts])	PASS	-
3.8	§2.1051 §22.917(a) §24.238(a) §27.53(h) §27.53(g)	Conducted Spurious Emission (5G NR n5) (5G NR n2, n25) (5G NR n66) (5G NR n71)	< 43+10log10(P[Watts])	PASS	-
3.9	§2.1055	Frequency Stability Temperature & Voltage	< 2.5 ppm for Part 22	PASS	-
	§22.355		Within Authorized Band		
	§24.235 §27.54				
4.4	§2.1053 §22.917(a) §24.238(a) §27.53(h) §27.53(g)	Radiated Spurious Emission (5G NR n5) (5G NR n2, n25) (5G NR n66) (5G NR n71)	< 43+10log ₁₀ (P[Watts])	PASS	Under limit 24.99 dB at 2014.000 MHz

Declaration of Conformity:

The test results with all measurement uncertainty excluded are presented in accordance with the regulation limits or requirements declared by manufacturers.

Comments and Explanations:

The declared of product specification for EUT presented in the report are provided by the manufacturer, and the manufacturer takes all the responsibilities for the accuracy of product specification.



1 General Description

1.1 Applicant

LENOVO (BEIJING) LIMITED

201-H2-6, Floor 2, Building 2, No.6 Shangdi West Road, Haidian District, Beijing, China 100085

1.2 Manufacturer

Lenovo PC HK Limited

23/F, Lincoln House, Taikoo Place 979 King's Road, Quarry Bay, Hong Kong, P.R. China

1.3 Product Feature of Equipment Under Test

Product Feature	
Equipment	Mobile Phone
Brand Name	Lenovo
Model Name	Lenovo L70081
FCC ID	A5MLM21C81
EUT supports Radios application	CDMA/GSM/WCDMA/LTE/5G NR WLAN 2.4GHz 802.11b/g/n HT20/HT40 WLAN 2.4GHz 802.11ac VHT20/VHT40 WLAN 2.4GHz 802.11ax HE20/HE40 WLAN 5GHz 802.11a/n HT20/HT40 WLAN 5GHz 802.11ac VHT20/VHT40/VHT80/VHT160 WLAN 5GHz 802.11ax HE20/HE40/HE80/HE160 Bluetooth BR/EDR/LE GNSS/NFC
IMEI Code	Conducted: N/A Radiation: 865576050015018
HW Version	DVT2
SW Version	L70081_CN_OPEN_UD_Q00017.0_R_ZUI_12.5.020_ST_210219_qpst
EUT Stage	Identical Prototype



1.4 Product Specification of Equipment Under Test

Standards-related Product Specification	
Tx Frequency	5G NR n2 : 1850 MHz ~ 1910 MHz 5G NR n5 : 824 MHz ~ 849 MHz 5G NR n25 : 1850 MHz ~ 1915 MHz 5G NR n66 : 1710 MHz ~ 1780 MHz 5G NR n71: 663 MHz ~ 698 MHz
Rx Frequency	5G NR n2 : 1930 MHz ~ 1990 MHz 5G NR n5 : 869 MHz ~ 894 MHz 5G NR n25 : 1930 MHz ~ 1995 MHz 5G NR n66 : 2110 MHz~ 2200 MHz 5G NR n71: 617 MHz ~ 652 MHz
Bandwidth	n2, n5, n25,n66, n71: 5MHz / 10MHz / 15MHz / 20MHz
SCS	15kHz
Antenna Gain	n2: -3.80 dBi n5: -2.00 dBi n25: -3.80 dBi n66: -2.00 dBi n71: -3.50 dBi
Type of Modulation	CP-OFDM: QPSK / 16QAM / 64QAM / 256QAM DFT-s-OFDM: PI/2 BPSK / QPSK / 16QAM / 64QAM / 256QAM

1.5 Modification of EUT

No modifications are made to the EUT during all test items.

1.6 Maximum ERP/EIRP Power, Frequency Tolerance, and Emission Designator

5G NR n2		PI/2 BPSK / QPSK		16QAM / 64QAM / 256QAM	
BW (MHz)	Frequency Range (MHz)	Emission Designator (99%OBW)	Maximum EIRP(W)	Emission Designator (99%OBW)	Maximum EIRP(W)
20	1860.0 ~ 1900.0	19M5G7D	0.0805	19M5W7D	0.0643
Frequency Tolerance (ppm)		0.0033			

5G NR n5		PI/2 BPSK / QPSK		16QAM / 64QAM / 256QAM	
BW (MHz)	Frequency Range (MHz)	Emission Designator (99%OBW)	Maximum ERP(W)	Emission Designator (99%OBW)	Maximum ERP(W)
20	834.0 ~ 839.0	19M3G7D	0.0760	19M4W7D	0.0597
Frequency Tolerance (ppm)		0.0041			



5G NR n25		PI/2 BPSK / QPSK		16QAM / 64QAM / 256QAM	
BW (MHz)	Frequency Range (MHz)	Emission Designator (99%OBW)	Maximum ERP(W)	Emission Designator (99%OBW)	Maximum ERP(W)
20	1860.0 ~ 1905.0	19M5G7D	0.0805	19M5W7D	0.0643
Frequency Tolerance (ppm)		0.0033			

5G NR n66		PI/2 BPSK / QPSK		16QAM / 64QAM / 256QAM	
BW (MHz)	Frequency Range (MHz)	Emission Designator (99%OBW)	Maximum EIRP(W)	Emission Designator (99%OBW)	Maximum EIRP(W)
20	1720.0 ~ 1770.0	19M2G7D	0.1236	19M3W7D	0.0989
Frequency Tolerance (ppm)		0.0035			

5G NR n71		PI/2 BPSK / QPSK		16QAM / 64QAM / 256QAM	
BW (MHz)	Frequency Range (MHz)	Emission Designator (99%OBW)	Maximum ERP(W)	Emission Designator (99%OBW)	Maximum ERP(W)
20	673.0 ~ 688.0	19M5G7D	0.0524	19M5W7D	0.0417
Frequency Tolerance (ppm)		0.0035			

Note:

1. 5G NR Band n25 overlaps the entire frequency range of Band n2. Therefore, the conducted test results provided in this report covers Band n25 as well as Band n2.
2. Based on engineering evaluation, only the maximum bandwidth and the worst modulation test results are shown in the report.



1.7 Testing Location

Sporton International (Kunshan) Inc. is accredited to ISO/IEC 17025:2017 by American Association for Laboratory Accreditation with Certificate Number 5145.02.

Test Firm	Sporton International (Kunshan) Inc.		
Test Site Location	No. 1098, Pengxi North Road, Kunshan Economic Development Zone Jiangsu Province 215300 People's Republic of China TEL : +86-512-57900158 FAX : +86-512-57900958		
Test Site No.	Sporton Site No.	FCC Designation No.	FCC Test Firm Registration No.
	03CH04-KS TH01-KS	CN1257	314309

1.8 Test Software

Item	Site	Manufacturer	Name	Version
1.	03CH04-KS	AUDIX	E3	6.2009-8-24a

1.9 Applicable Standards

According to the specifications of the manufacturer, the EUT must comply with the requirements of the following standards:

- ♦ 47 CFR Part 2, 22, 24, 27
- ♦ ANSI C63.26-2015
- ♦ FCC KDB 971168 D01 Power Meas License Digital Systems v03r01
- ♦ FCC KDB 412172 D01 Determining ERP and EIRP v01r01

Remark:

All test items were verified and recorded according to the standards and without any deviation during the test.



2 Test Configuration of Equipment Under Test

2.1 Test Mode

Antenna port conducted and radiated test items are performed according to KDB 971168 D01 Power Meas License Digital Systems v03r01 with maximum output power.

For radiated measurement, pre-scanned in three orthogonal panels, X, Y, Z. The worst cases were recorded in this report.

The device is investigated from 30MHz to 10 times of fundamental signal for radiated spurious emission test under different RB size/offset and modulations in exploratory test. Subsequently, only the worst case emissions are reported.

Orthogonal Planes of EUT	X Plane	Y Plane	Z Plane
			

Test Items	5G NR	Bandwidth (MHz)						Modulation					RB #		Test Channel			
		5	10	15	20	50-90	100	PI/2 BPSK	QPSK	16QAM	64QAM	256QAM	1	Full	L	M	H	
Max. Output Power	n2	v	v	v	v	-	-	v	v	v	v	v	v	v	v	v	v	v
	n5	v	v	v	v	-	-	v	v	v	v	v	v	v	v	v	v	v
	n25	v	v	v	v	-	-	v	v	v	v	v	v	v	v	v	v	v
	n66	v	v	v	v	-	-	v	v	v	v	v	v	v	v	v	v	v
	n71	v	v	v	v	-	-	v	v	v	v	v	v	v	v	v	v	v
Peak-to-Average Ratio	n5				v	-	-		v					v		v		
	n25				v	-	-		v					v		v		
	n66				v	-	-		v					v		v		
	n71				v	-	-		v					v		v		
26dB and 99% Bandwidth	n5				v	-	-		v	v				v		v		
	n25				v	-	-		v	v				v		v		
	n66				v	-	-		v	v				v		v		
	n71				v	-	-		v	v				v		v		



Test Items	Band	Bandwidth (MHz)						Modulation					RB #		Test Channel			
		5	10	15	20	50-90	100	PI/2 BPSK	QPSK	16QAM	64QAM	256QAM	1	Full	L	M	H	
Conducted Band Edge	n5	v	v	v	v	-	-	v	v	v	v	v	v		v		v	
	n25	v	v	v	v	-	-	v	v	v	v	v	v		v		v	
	n66	v	v	v	v	-	-	v	v	v	v	v	v		v		v	
	n71	v	v	v	v	-	-	v	v	v	v	v	v		v		v	
Conducted Spurious Emission	n5	v	v	v	v	-	-		v				v		v	v	v	
	n25	v	v	v	v	-	-		v				v		v	v	v	
	n66	v	v	v	v	-	-		v				v		v	v	v	
	n71	v	v	v	v	-	-		v				v		v	v	v	
Frequency Stability	n5				v	-	-		v					v		v		
	n25				v	-	-		v					v		v		
	n66				v	-	-		v					v		v		
	n71				v	-	-		v					v		v		
E.R.P / E.I.R.P	n2	v	v	v	v	-	-	v	v	v	v	v	v	v	v	v	v	
	n5	v	v	v	v	-	-	v	v	v	v	v	v	v	v	v	v	
	n25	v	v	v	v	-	-	v	v	v	v	v	v	v	v	v	v	
	n66	v	v	v	v	-	-	v	v	v	v	v	v	v	v	v	v	
	n71	v	v	v	v	-	-	v	v	v	v	v	v	v	v	v	v	
Radiated Spurious Emission	n5	Worst Case															v	
	n25	Worst Case															v	
	n66	Worst Case															v	
	n71	Worst Case															v	
Note	<ol style="list-style-type: none"> The mark "v" means that this configuration is chosen for testing The mark "-" means that this bandwidth is not supported. The device is investigated from 30MHz to 10 times of fundamental signal for radiated spurious emission test under different RB size/offset and modulations in exploratory test. Subsequently, only the worst case emissions are reported. 5G NR supports SA and NSA mode (refer to the Operation Description), based on engineering evaluation, only show the worst SA mode in the report. For modulation of CP-OFDM and DFT-s-OFDM, the maximum power of CP-OFDM is lower than DFT-s-OFDM modulation, therefore, we chose higher power (DFT-s-OFDM modulation) to perform all tests and show in the report. Based on engineering evaluation, only the worst modulations test results are shown in the report. 																	

2.2 Connection Diagram of Test System

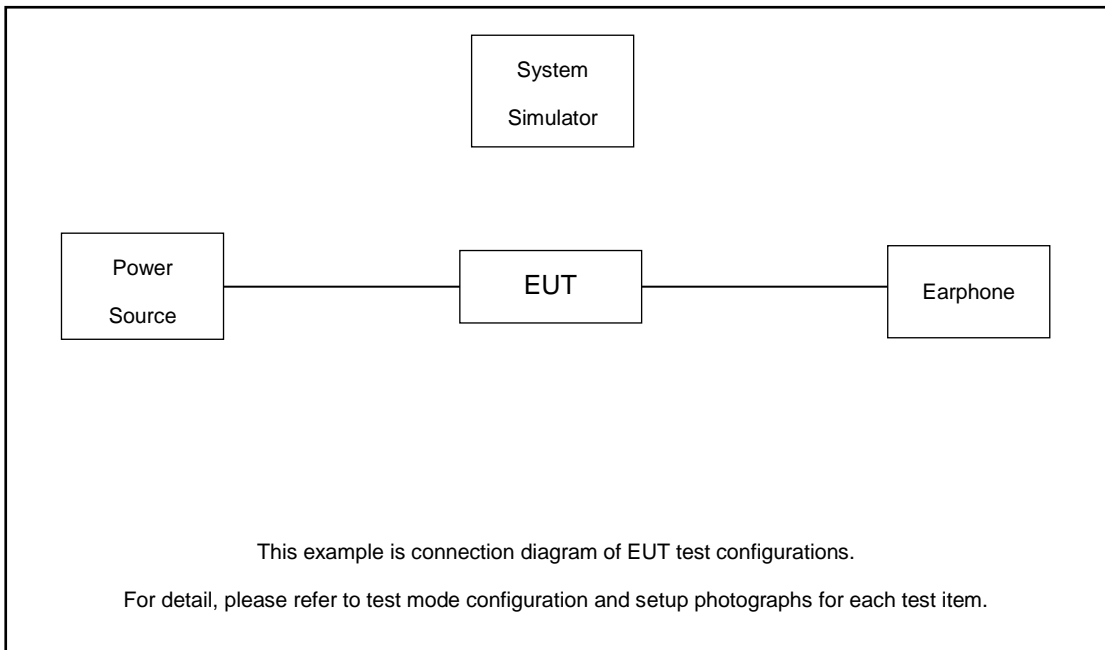

2.3 Support Unit used in test configuration and system

Item	Equipment	Trade Name	Model No.	FCC ID	Data Cable	Power Cord
1.	DC Power Supply	GW	GPS-3030D	N/A	N/A	Unshielded, 1.8 m
2.	LTE Base Station	Anritsu	MT8821C	N/A	N/A	Unshielded, 1.8 m
3.	NR Base Station	Anritsu	MT8000A	N/A	N/A	Unshielded, 1.8 m

2.4 Measurement Results Explanation Example

For all conducted test items:

The offset level is set in the spectrum analyzer to compensate the RF cable loss between EUT conducted output port and spectrum analyzer. With the offset compensation, the spectrum analyzer reading level is exactly the EUT RF output level.

The spectrum analyzer offset is derived from RF cable loss.

Offset = RF cable loss.

Following shows an offset computation example with cable loss 4.90 dB.

Example :

$$\begin{aligned} \text{Offset(dB)} &= \text{RF cable loss(dB)}. \\ &= 4.90 \text{ (dB)} \end{aligned}$$



2.5 Frequency List of Low/Middle/High Channels

5G NR n2 Channel and Frequency List				
BW [MHz]	Channel/Frequency(MHz)	Lowest	Middle	Highest
20	Channel	372000	376000	380000
	Frequency	1860	1880	1900
15	Channel	371500	376000	380500
	Frequency	1857.5	1880	1902.5
10	Channel	371000	376000	381000
	Frequency	1855	1880	1905
5	Channel	370500	376000	381500
	Frequency	1852.5	1880	1907.5

5G NR n5 Channel and Frequency List				
BW [MHz]	Channel/Frequency(MHz)	Lowest	Middle	Highest
20	Channel	166800	167300	167800
	Frequency	834	836.5	839
15	Channel	166300	167300	168300
	Frequency	831.5	836.5	841.5
10	Channel	165800	167300	168800
	Frequency	829	836.5	844
5	Channel	165300	167300	169300
	Frequency	826.5	836.5	846.5

5G NR n25 Channel and Frequency List				
BW [MHz]	Channel/Frequency(MHz)	Lowest	Middle	Highest
20	Channel	372000	376500	381000
	Frequency	1860	1882.5	1905
15	Channel	371500	376500	381500
	Frequency	1857.5	1882.5	1907.5
10	Channel	371000	376500	382000
	Frequency	1855	1882.5	1910
5	Channel	370500	376500	382500
	Frequency	1852.5	1882.5	1912.5



5G NR n66 Channel and Frequency List				
BW [MHz]	Channel/Frequency(MHz)	Lowest	Middle	Highest
20	Channel	344000	349000	354000
	Frequency	1720	1745	1770
15	Channel	343500	349000	354500
	Frequency	1717.5	1745	1772.5
10	Channel	343000	349000	355000
	Frequency	1715	1745	1775
5	Channel	342500	349000	355500
	Frequency	1712.5	1745	1777.5

5G NR n71 Channel and Frequency List				
BW [MHz]	Channel/Frequency(MHz)	Lowest	Middle	Highest
20	Channel	134600	136100	137600
	Frequency	673	680.5	688
15	Channel	134100	136100	138100
	Frequency	670.5	680.5	690.5
10	Channel	133600	136100	138600
	Frequency	668	680.5	693
5	Channel	133100	136100	139100
	Frequency	665.5	680.5	695.5

3 Conducted Test Items

3.1 Measuring Instruments

See list of measuring instruments of this test report.

3.2 Test Setup

3.2.1 Conducted Output Power



3.2.2 Peak-to-Average Ratio, Occupied Bandwidth ,Conducted Band-Edge and Conducted Spurious Emission



3.2.3 Frequency Stability

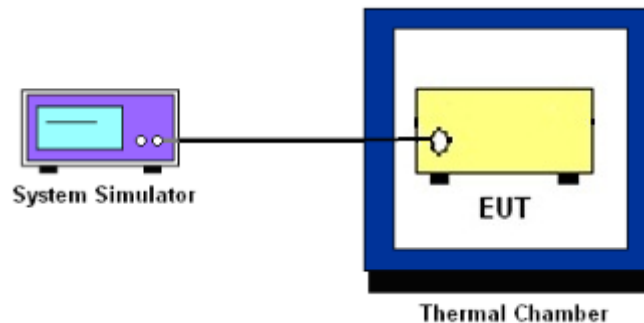

3.3 Test Result of Conducted Test

Please refer to Appendix A.



3.4 Conducted Output Power and ERP/EIRP

3.4.1 Description of the Conducted Output Power Measurement and ERP/EIRP Measurement

A system simulator was used to establish communication with the EUT. Its parameters were set to force the EUT transmitting at maximum output power. The measured power in the radio frequency on the transmitter output terminals shall be reported.

The ERP of mobile transmitters must not exceed 7 Watts for 5G NR n5.

The ERP of mobile transmitters must not exceed 3 Watts for 5G NR n71.

The EIRP of mobile transmitters must not exceed 2 Watts for 5G NR n2 and n25.

The EIRP of mobile transmitters must not exceed 1 Watts for 5G NR n66.

According to KDB 412172 D01 Power Approach,

$EIRP = P_T + G_T - L_C$, $ERP = EIRP - 2.15$, where

P_T = transmitter output power in dBm

G_T = gain of the transmitting antenna in dBi

L_C = signal attenuation in the connecting cable between the transmitter and antenna in dB

3.4.2 Test Procedures

1. The testing follows ANSI C63.26 Section 5.2
2. The transmitter output port was connected to the system simulator.
3. Set EUT at maximum power through the system simulator.
4. Select lowest, middle, and highest channels for each band and different modulation.
5. Measure and record the power level from the system simulator.



3.5 Peak-to-Average Ratio

3.5.1 Description of the PAR Measurement

Power Complementary Cumulative Distribution Function (CCDF) curves provide a means for characterizing the power peaks of a digitally modulated signal on a statistical basis. A CCDF curve depicts the probability of the peak signal amplitude exceeding the average power level. Most contemporary measurement instrumentation include the capability to produce CCDF curves for an input signal provided that the instrument's resolution bandwidth can be set wide enough to accommodate the entire input signal bandwidth. In measuring transmissions in this band using an average power technique, the peak-to-average ratio (PAR) of the transmission may not exceed 13 dB.

3.5.2 Test Procedures

1. The testing follows ANSI C63.26 Section 5.2.3.4 (CCDF).
2. The EUT was connected to spectrum and system simulator via a power divider.
3. Set the CCDF (Complementary Cumulative Distribution Function) option in spectrum analyzer.
4. The highest RF powers were measured and recorded the maximum PAPR level associated with a probability of 0.1 %.
5. Record the deviation as Peak to Average Ratio.

3.6 Occupied Bandwidth

3.6.1 Description of Occupied Bandwidth Measurement

The occupied bandwidth is the width of a frequency band such that, below the lower and above the upper frequency limits, the mean powers emitted are each equal to a specified percentage 0.5% of the total mean transmitted power.

The 26 dB emission bandwidth is defined as the frequency range between two points, one above and one below the carrier frequency, at which the spectral density of the emission is attenuated 26 dB below the maximum in-band spectral density of the modulated signal. Spectral density (power per unit bandwidth) is to be measured with a detector of resolution bandwidth equal to approximately 1.0% of the emission bandwidth.



3.6.2 Test Procedures

1. The testing follows ANSI C63.26 Section 5.4
2. The EUT was connected to spectrum analyzer and system simulator via a power divider.
3. The spectrum analyzer center frequency is set to the nominal EUT channel center frequency. The span range for the spectrum analyzer shall be between two and five times the anticipated OBW.
4. The nominal resolution bandwidth (RBW) shall be in the range of 1 to 5 % of the anticipated OBW, and the VBW shall be at least 3 times the RBW.
5. Set the detection mode to peak, and the trace mode to max hold.
6. Determine the reference value: Set the EUT to transmit a modulated signal. Allow the trace to stabilize. Set the spectrum analyzer marker to the highest level of the displayed trace.
(this is the reference value)
7. Determine the “-26 dB down amplitude” as equal to (Reference Value – X).
8. Place two markers, one at the lowest and the other at the highest frequency of the envelope of the spectral display such that each marker is at or slightly below the “-X dB down amplitude” determined in step 6. If a marker is below this “-X dB down amplitude” value it shall be placed as close as possible to this value. The OBW is the positive frequency difference between the two markers.
9. Use the 99 % power bandwidth function of the spectrum analyzer and report the measured bandwidth.



3.7 Conducted Band Edge

3.7.1 Description of Conducted Band Edge Measurement

22.917(a)

For operations in the 824 – 849 MHz band, the FCC limit is $43 + 10\log_{10}(P[\text{Watts}])$ dB below the transmitter power $P(\text{Watts})$ in a 100kHz bandwidth. However, in the 1MHz bands immediately outside and adjacent to the licensee's frequency block, a resolution bandwidth of at least one percent of the emission bandwidth of the fundamental emission of the transmitter may be employed.

24.238 (a)

For operations in the 1850-1910 and 1930-1990 MHz band, the FCC limit is $43 + 10\log_{10}(P[\text{Watts}])$ dB below the transmitter power $P(\text{Watts})$ in a 1MHz bandwidth. However, in the 1 MHz bands immediately outside and adjacent to the frequency block a resolution bandwidth of at least one percent of the emission bandwidth of the fundamental emission of the transmitter may be employed.

27.53 (h)

For operations in the 1710 – 1755 MHz band, the FCC limit is $43 + 10\log_{10}(P[\text{Watts}])$ dB below the transmitter power $P(\text{Watts})$ in a 1 MHz bandwidth. However, in the 1MHz bands immediately outside and adjacent to the licensee's frequency block, a resolution bandwidth of at least one percent of the emission bandwidth of the fundamental emission of the transmitter may be employed.

27.53 (g)

For operations in the 600MHz band and 698 -746 MHz band, the FCC limit is $43 + 10\log_{10}(P[\text{Watts}])$ dB below the transmitter power $P(\text{Watts})$ in a 100 kHz bandwidth. However, in the 100 kilohertz bands immediately outside and adjacent to a licensee's frequency block, a resolution bandwidth of at least 30 kHz may be employed.



3.7.2 Test Procedures

1. The testing follows ANSI C63.26 section 5.7
2. The EUT was connected to spectrum analyzer and system simulator via a power divider.
3. The band edges of low and high channels for the highest RF powers were measured.
4. Set RBW \geq 1% EBW in the 1MHz band immediately outside and adjacent to the band edge.
5. Beyond the 1 MHz band from the band edge, RBW=1MHz was used.
6. Set spectrum analyzer with RMS detector.
7. The RF fundamental frequency should be excluded against the limit line in the operating frequency band.
8. Checked that all the results comply with the emission limit line.

Example:

The limit line is derived from $43 + 10\log(P)$ dB below the transmitter power P(Watts)
= P(W)- [43 + 10log(P)] (dB)
= [30 + 10log(P)] (dBm) - [43 + 10log(P)] (dB) = -13dBm.



3.8 Conducted Spurious Emission

3.8.1 Description of Conducted Spurious Emission Measurement

The power of any emission outside of the authorized operating frequency ranges must be lower than the transmitter power (P) by a factor of at least $43 + 10 \log (P)$ dB.

It is measured by means of a calibrated spectrum analyzer and scanned from 30 MHz up to a frequency including its 10th harmonic.

3.8.2 Test Procedures

1. The testing follows ANSI C63.26 section 5.7
2. The EUT was connected to spectrum analyzer and system simulator via a power divider.
3. The RF output of EUT was connected to the spectrum analyzer by RF cable and attenuator. The path loss was compensated to the results for each measurement.
4. The middle channel for the highest RF power within the transmitting frequency was measured.
5. The conducted spurious emission for the whole frequency range was taken.
6. Make the measurement with the spectrum analyzer's RBW = 1MHz, VBW = 3MHz.
7. Set spectrum analyzer with RMS detector.
8. Taking the record of maximum spurious emission.
9. The RF fundamental frequency should be excluded against the limit line in the operating frequency band.
10. The limit line is derived from $43 + 10\log(P)$ dB below the transmitter power P(Watts)
= P(W)- [43 + 10log(P)] (dB)
= [30 + 10log(P)] (dBm) - [43 + 10log(P)] (dB)
= -13dBm.



3.9 Frequency Stability

3.9.1 Description of Frequency Stability Measurement

The frequency stability shall be measured by variation of ambient temperature and variation of primary supply voltage to ensure that the fundamental emission stays within the authorized frequency block. The frequency stability of the transmitter shall be maintained within $\pm 0.00025\%$ ($\pm 2.5\text{ppm}$) of the center frequency.

3.9.2 Test Procedures for Temperature Variation

1. The testing follows ANSI C63.26 section 5.6.4
2. The EUT was set up in the thermal chamber and connected with the system simulator.
3. With power OFF, the temperature was decreased to -30°C and the EUT was stabilized before testing. Power was applied and the maximum change in frequency was recorded within one minute.
4. With power OFF, the temperature was raised in 10°C step up to 50°C . The EUT was stabilized at each step for at least half an hour. Power was applied and the maximum frequency change was recorded within one minute.

3.9.3 Test Procedures for Voltage Variation

1. The testing follows ANSI C63.26 section 5.6.5
2. The EUT was placed in a temperature chamber at $20\pm 5^{\circ}\text{C}$ and connected with the system simulator.
3. The power supply voltage to the EUT was varied from 85% to 115% of the nominal value for other than hand carried battery equipment.
4. For hand carried, battery powered equipment, reduce the primary ac or dc supply voltage to the battery operating end point, which shall be specified by the manufacturer.
5. The variation in frequency was measured for the worst case.

4 Radiated Test Items

4.1 Measuring Instruments

See list of measuring instruments of this test report.

4.2 Test Setup

4.2.1 For radiated test from 30MHz to 1GHz

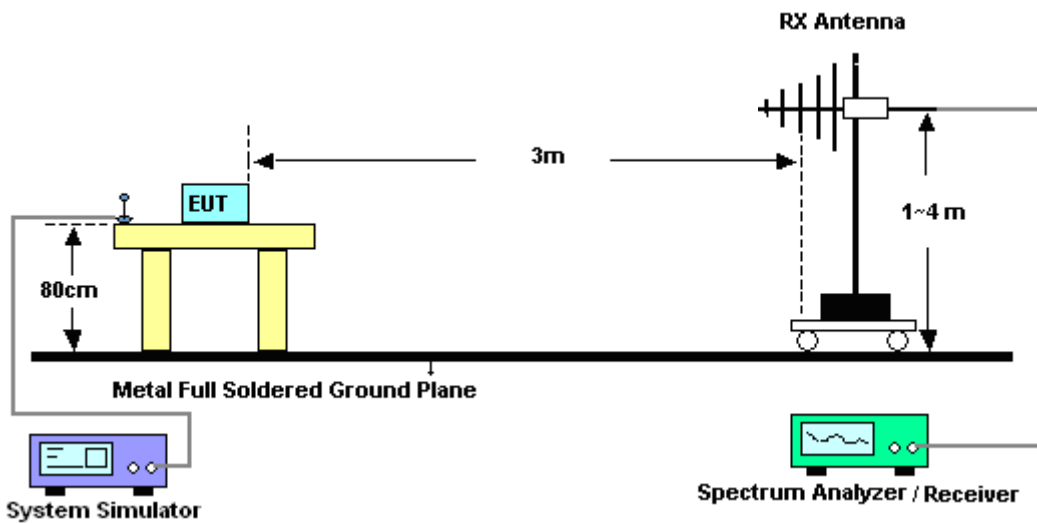

4.2.2 For radiated test above 1GHz

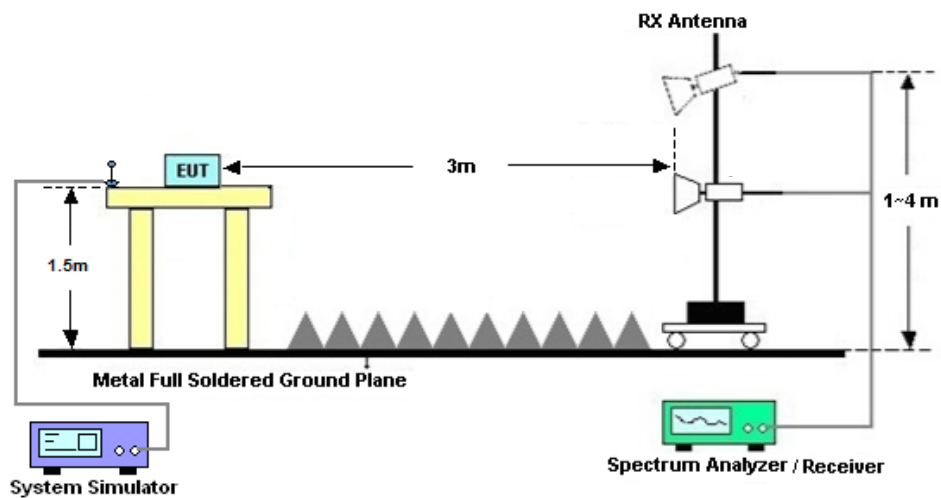

4.3 Test Result of Radiated Test

Please refer to Appendix B.



4.4 Radiated Spurious Emission

4.4.1 Description of Radiated Spurious Emission

The radiated spurious emission was measured by substitution method according to ANSI C63.26. The power of any emission outside of the authorized operating frequency ranges must be attenuated below the transmitter power (P) by a factor of at least $43 + 10 \log (P)$ dB.

The spectrum is scanned from 30 MHz up to a frequency including its 10th harmonic.

4.4.2 Test Procedures

1. The testing follows ANSI C63.26 Section 5.5
2. The EUT was placed on a turntable with 0.8 meter height for frequency below 1GHz and 1.5 meter height for frequency above 1GHz respectively above ground.
3. The EUT was set 3 meters from the receiving antenna mounted on the antenna tower.
4. The table was rotated 360 degrees to determine the position of the highest spurious emission.
5. The height of the receiving antenna is varied between 1m to 4m to search the maximum spurious emission for both horizontal and vertical polarizations.
6. During the measurement, the system simulator parameters were set to force the EUT transmitting at maximum output power.
7. Make the measurement with the spectrum analyzer's RBW = 1MHz, VBW = 3MHz, taking the record of maximum spurious emission.
8. A horn antenna was substituted in place of the EUT and was driven by a signal generator.
9. Tune the output power of signal generator to the same emission level with EUT maximum spurious emission.
10. $EIRP (dBm) = S.G. Power - Tx Cable Loss + Tx Antenna Gain$
11. $ERP (dBm) = EIRP - 2.15$
12. The RF fundamental frequency should be excluded against the limit line in the operating frequency band.

The limit line is derived from $43 + 10\log(P)$ dB below the transmitter power P(Watts)
 $= P(W) - [43 + 10\log(P)] (dB)$
 $= [30 + 10\log(P)] (dBm) - [43 + 10\log(P)] (dB)$
 $= -13dBm.$



5 List of Measuring Equipment

Instrument	Manufacturer	Model No.	Serial No.	Characteristics	Calibration Date	Test Date	Due Date	Remark
Spectrum Analyzer	R&S	FSV40	101040	10Hz~40GHz	Nov. 01, 2020	Apr. 01, 2021	Oct. 31, 2021	Conducted (TH01-KS)
Temperature & humidity chamber	Hongzhan	LP-150U	H2014011440	-40~+150°C 20%~95%RH	Jul. 03, 2020	Apr. 01, 2021	Jul. 02, 2021	Conducted (TH01-KS)
EXA Spectrum Analyzer	Keysight	N9010A	MY55150244	10Hz-44G,MAX 30dB	Apr. 13, 2021	Apr. 28, 2021	Apr. 12, 2022	Radiation (03CH04-KS)
Bilog Antenna	TeseQ	CBL6111D	49922	30MHz-1GHz	Jun. 08, 2020	Apr. 28, 2021	Jun. 07, 2021	Radiation (03CH04-KS)
Horn Antenna	Schwarzbeck	BBHA9120D	1356	1GHz~18GHz	Apr. 18, 2021	Apr. 28, 2021	Apr. 17, 2022	Radiation (03CH04-KS)
SHF-EHF Horn	Com-power	AH-840	101115	18GHz~40GHz	Jan. 06, 2021	Apr. 28, 2021	Jan. 05, 2022	Radiation (03CH04-KS)
Amplifier	SONOMA	310N	187289	9KHz-1GHz	Jan. 06, 2021	Apr. 28, 2021	Jan. 05, 2022	Radiation (03CH04-KS)
Amplifier	MITEQ	EM18G40G GA	060728	18~40GHz	Jan. 07, 2021	Apr. 28, 2021	Jan. 06, 2022	Radiation (03CH04-KS)
high gain Amplifier	MITEQ	AMF-7D-00 101800-30-1 0P	2025788	1Ghz-18Ghz	Jan. 06, 2021	Apr. 28, 2021	Jan. 05, 2022	Radiation (03CH04-KS)
Amplifier	Keysight	83017A	MY57280106	500MHz~26.5GHz	Oct. 14, 2020	Apr. 28, 2021	Oct. 13, 2021	Radiation (03CH04-KS)
AC Power Source	Chroma	61601	F104090004	N/A	NCR	Apr. 28, 2021	NCR	Radiation (03CH04-KS)
Turn Table	ChamPro	EM 1000-T	060762-T	0~360 degree	NCR	Apr. 28, 2021	NCR	Radiation (03CH04-KS)
Antenna Mast	ChamPro	EM 1000-A	060762-A	1 m~4 m	NCR	Apr. 28, 2021	NCR	Radiation (03CH04-KS)

NCR: No Calibration Required



6 Uncertainty of Evaluation

The measurement uncertainties shown below were calculated in accordance with the requirements of ANSI 63.26-2015. All the measurement uncertainty value were shown with a coverage $K=2$ to indicate 95% level of confidence. The measurement data show herein meets or exceeds the CISPR measurement uncertainty values specified in CISPR 16-4-2 and can be compared directly to specified limit to determine compliance.

Uncertainty of Radiated Emission Measurement (30 MHz ~ 1000 MHz)

Measuring Uncertainty for a Level of Confidence of 95% ($U = 2Uc(y)$)	3.3dB
---	-------

Uncertainty of Radiated Emission Measurement (1 GHz ~ 18 GHz)

Measuring Uncertainty for a Level of Confidence of 95% ($U = 2Uc(y)$)	2.8dB
---	-------

Uncertainty of Radiated Emission Measurement (18 GHz ~ 40 GHz)

Measuring Uncertainty for a Level of Confidence of 95% ($U = 2Uc(y)$)	2.8dB
---	-------



Appendix A. Test Results of Conducted Test

Conducted Output Power(Average power and EIRP)

5G NR n2

BW [MHz]	Modulation	RB Size	RB Offset	Power Low Ch. / Freq.	Power Middle Ch. / Freq.	Power High Ch. / Freq.	Gain	EIRP	EIRP	EIRP
Channel				372000	376000	380000		L	M	H
Frequency (MHz)				1860	1880	1900				
20	PI/2 BPSK	1	1	22.41	22.61	22.51	-3.8	0.0726	0.0760	0.0743
20	PI/2 BPSK	1	53	22.51	22.82	22.62		0.0743	0.0798	0.0762
20	PI/2 BPSK	1	104	22.53	22.53	22.62		0.0746	0.0746	0.0762
20	PI/2 BPSK	50	0	22.03	22.23	22.06	-3.8	0.0665	0.0697	0.0670
20	PI/2 BPSK	50	28	22.62	22.72	22.66	-3.8	0.0762	0.0780	0.0769
20	PI/2 BPSK	50	56	22.13	22.21	22.13	-3.8	0.0681	0.0693	0.0681
20	PI/2 BPSK	100	0	22.06	22.23	22.11		0.0670	0.0697	0.0678
20	QPSK	1	1	22.67	22.68	22.77	-3.8	0.0771	0.0773	0.0789
20	QPSK	1	53	22.65	22.52	22.51		0.0767	0.0745	0.0743
20	QPSK	1	104	22.63	22.36	22.44		0.0764	0.0718	0.0731
20	QPSK	50	0	21.56	21.32	21.59	-3.8	0.0597	0.0565	0.0601
20	QPSK	50	28	22.63	22.35	22.71	-3.8	0.0764	0.0716	0.0778
20	QPSK	50	56	21.72	21.71	21.63	-3.8	0.0619	0.0618	0.0607
20	QPSK	100	0	21.61	21.44	21.68		0.0604	0.0581	0.0614
20	16QAM	1	1	21.52	21.73	21.36	-3.8	0.0592	0.0621	0.0570
20	64QAM	1	1	20.32	20.13	20.03	-3.8	0.0449	0.0430	0.0420
20	256QAM	1	1	18.12	18.63	18.32	-3.8	0.0270	0.0304	0.0283
Channel				371500	376000	380500	Tune-up limit (dBm)	MPR (dB)	Channel	
Frequency (MHz)				1857.5	1880	1902.5			Frequency (MHz)	
15	QPSK	1	1	22.58	22.56	22.36	-3.8	0.0755	0.0752	0.0718
15	16QAM	1	1	21.33	21.36	20.63	-3.8	0.0566	0.0570	0.0482
Channel				371000	376000	381000	Tune-up limit (dBm)	MPR (dB)	Channel	
Frequency (MHz)				1855	1880	1905			Frequency (MHz)	
10	QPSK	1	1	22.55	22.53	22.51	-3.8	0.0750	0.0746	0.0743
10	16QAM	1	1	21.36	21.55	21.21	-3.8	0.0570	0.0596	0.0551
Channel				370500	376000	381500	Tune-up limit (dBm)	MPR (dB)	Channel	
Frequency (MHz)				1852.5	1880	1907.5			Frequency (MHz)	
5	QPSK	1	1	22.52	22.57	22.59	-3.8	0.0745	0.0753	0.0757
5	16QAM	1	1	21.37	21.41	21.33	-3.8	0.0571	0.0577	0.0566



5G NR n5

BW [MHz]	Modulation	RB Size	RB Offset	Power Low Ch. / Freq.	Power Middle Ch. / Freq.	Power High Ch. / Freq.	Gain	ERP	ERP	ERP
Channel				166800	167300	167800	Gain	L	M	H
Frequency (MHz)				834	836.5	839		L	M	H
20	PI/2 BPSK	1	1	22.68	22.59	22.61	-2.0	0.0713	0.0698	0.0701
20	QPSK	1	1	22.96	22.85	22.77	-2.0	0.0760	0.0741	0.0728
20	QPSK	1	53	22.53	22.56	22.34		0.0689	0.0693	0.0659
20	QPSK	1	104	22.16	22.28	22.37		0.0632	0.0650	0.0664
20	QPSK	50	0	22.25	22.22	22.14	-2.0	0.0646	0.0641	0.0630
20	QPSK	50	28	22.16	22.19	22.08		0.0632	0.0637	0.0621
20	QPSK	50	56	22.34	22.26	22.19		0.0659	0.0647	0.0637
20	QPSK	100	0	22.22	22.15	22.23	-2.0	0.0641	0.0631	0.0643
20	16QAM	1	1	21.89	21.91	21.79		0.0594	0.0597	0.0581
20	64QAM	1	1	20.11	20.16	20.08		0.0394	0.0399	0.0392
20	256QAM	1	1	19.11	19.22	19.17	-2.0	0.0313	0.0321	0.0318
Channel				166300	167300	168300	Gain	L	M	H
Frequency (MHz)				831.5	836.5	841.5		L	M	H
15	QPSK	1	1	22.78	22.69	22.57	-2.0	0.0729	0.0714	0.0695
15	16QAM	1	1	21.68	21.77	21.65	-2.0	0.0566	0.0578	0.0562
Channel				165800	167300	168800	Gain	L	M	H
Frequency (MHz)				829	836.5	844		L	M	H
10	QPSK	1	1	22.75	22.63	22.56	-2.0	0.0724	0.0705	0.0693
10	16QAM	1	1	21.54	21.67	21.53	-2.0	0.0548	0.0565	0.0547
Channel				165300	167300	169300	Gain	L	M	H
Frequency (MHz)				826.5	836.5	846.5		L	M	H
5	QPSK	1	1	22.55	22.58	22.37	-2.0	0.0692	0.0697	0.0664
5	16QAM	1	1	21.36	21.65	21.37	-2.0	0.0526	0.0562	0.0527



5G NR n25

BW [MHz]	Modulation	RB Size	RB Offset	Power Low Ch. / Freq.	Power Middle Ch. / Freq.	Power High Ch. / Freq.	Gain	EIRP	EIRP	EIRP
Channel				372000	376500	381000		L	M	H
Frequency (MHz)				1860	1882.5	1905				
20	PI/2 BPSK	1	1	22.71	22.69	22.62	-3.80	0.0778	0.0774	0.0762
20	PI/2 BPSK	1	53	22.63	22.62	22.25	-3.80	0.0764	0.0762	0.0700
20	PI/2 BPSK	1	104	22.51	22.52	21.35	-3.80	0.0743	0.0745	0.0569
20	PI/2 BPSK	50	0	22.13	22.12	21.89	-3.80	0.0681	0.0679	0.0644
20	PI/2 BPSK	50	28	22.65	22.65	22.41	-3.80	0.0767	0.0767	0.0726
20	PI/2 BPSK	50	56	22.11	22.13	22.01	-3.80	0.0678	0.0681	0.0662
20	PI/2 BPSK	100	0	22.12	22.12	21.92	-3.80	0.0679	0.0679	0.0649
20	QPSK	1	1	22.74	22.86	22.71	-3.80	0.0783	0.0805	0.0778
20	QPSK	1	53	22.56	22.62	22.65	-3.80	0.0752	0.0762	0.0767
20	QPSK	1	104	22.53	22.36	21.15	-3.80	0.0746	0.0718	0.0543
20	QPSK	50	0	21.66	21.68	21.44	-3.80	0.0611	0.0614	0.0581
20	QPSK	50	28	22.72	22.79	22.16	-3.80	0.0780	0.0793	0.0685
20	QPSK	50	56	21.63	21.65	21.47	-3.80	0.0607	0.0610	0.0585
20	QPSK	100	0	21.66	21.63	21.41	-3.80	0.0611	0.0607	0.0577
20	16QAM	1	1	21.85	21.86	21.88	-3.80	0.0638	0.0640	0.0643
20	64QAM	1	1	19.56	20.26	19.86	-3.80	0.0377	0.0443	0.0404
20	256QAM	1	1	18.23	18.26	18.33	-3.80	0.0277	0.0279	0.0284
Channel				371500	376500	381500	Gain	L	M	H
Frequency (MHz)				1857.5	1882.5	1907.5				
15	QPSK	1	1	22.58	22.65	22.38	-3.80	0.0755	0.0767	0.0721
15	16QAM	1	1	21.39	21.56	21.63				
Channel				371000	376500	382000	Gain	L	M	H
Frequency (MHz)				1855	1882.5	1910				
10	QPSK	1	1	22.58	22.59	22.54	-3.80	0.0755	0.0757	0.0748
10	16QAM	1	1	21.23	21.29	21.32				
Channel				370500	376500	382500	Gain	L	M	H
Frequency (MHz)				1852.5	1882.5	1912.5				
5	QPSK	1	1	22.58	22.59	22.61	-3.80	0.0755	0.0757	0.0760
5	16QAM	1	1	21.23	21.26	21.41				



5G NR n66

BW [MHz]	Modulation	RB Size	RB Offset	Power Low Ch. / Freq.	Power Middle Ch. / Freq.	Power High Ch. / Freq.	Gain	EIRP	EIRP	EIRP
Channel				344000	349000	354000				
Frequency (MHz)				1720	1745	1770		L	M	H
20	PI/2 BPSK	1	1	22.53	22.41	22.52	-2.00	0.1130	0.1099	0.1127
20	PI/2 BPSK	1	53	22.67	22.88	22.81		0.1167	0.1225	0.1205
20	PI/2 BPSK	1	104	22.51	22.77	22.81		0.1125	0.1194	0.1205
20	PI/2 BPSK	50	0	22.79	22.92	22.69	-2.00	0.1199	0.1236	0.1172
20	PI/2 BPSK	50	28	22.12	22.25	22.35		0.1028	0.1059	0.1084
20	PI/2 BPSK	50	56	22.44	22.76	22.36		0.1107	0.1191	0.1086
20	PI/2 BPSK	100	0	22.66	22.76	22.81	-2.00	0.1164	0.1191	0.1205
20	QPSK	1	1	22.87	22.83	22.91	-2.00	0.1222	0.1211	0.1233
20	QPSK	1	53	22.52	22.48	22.47		0.1127	0.1117	0.1114
20	QPSK	1	104	22.13	22.52	22.06		0.1030	0.1127	0.1014
20	QPSK	50	0	22.18	22.25	22.17	-2.00	0.1042	0.1059	0.1040
20	QPSK	50	28	22.26	22.13	22.19		0.1062	0.1030	0.1045
20	QPSK	50	56	22.22	22.17	21.96		0.1052	0.1040	0.0991
20	QPSK	100	0	22.25	22.17	21.99	-2.00	0.1059	0.1040	0.0998
20	16QAM	1	1	21.91	21.95	21.82	-2.00	0.0979	0.0989	0.0959
20	64QAM	1	1	20.15	20.03	20.09	-2.00	0.0653	0.0635	0.0644
20	256QAM	1	1	19.25	19.11	19.19	-2.00	0.0531	0.0514	0.0524
Channel				343500	349000	354500	Gain	EIRP	EIRP	EIRP
Frequency (MHz)				1717.5	1745	1772.5				
15	QPSK	1	1	22.56	22.41	22.35	-2.00	0.1138	0.1099	0.1084
15	16QAM	1	1	21.77	21.75	21.69	-2.00	0.0948	0.0944	0.0931
Channel				343000	349000	355000	Gain	EIRP	EIRP	EIRP
Frequency (MHz)				1715	1745	1775				
10	QPSK	1	1	22.61	22.65	22.52	-2.00	0.1151	0.1161	0.1127
10	16QAM	1	1	21.59	21.66	21.75	-2.00	0.0910	0.0925	0.0944
Channel				342500	349000	355500	Gain	EIRP	EIRP	EIRP
Frequency (MHz)				1712.5	1745	1777.5				
5	QPSK	1	1	22.71	22.65	22.63	-2.00	0.1178	0.1161	0.1156
5	16QAM	1	1	21.68	21.55	21.71	-2.00	0.0929	0.0902	0.0935



5G NR n71

BW [MHz]	Modulation	RB Size	RB Offset	Power Low Ch. / Freq.	Power Middle Ch. / Freq.	Power High Ch. / Freq.	Gain	ERP	ERP	ERP
Channel				134600	136100	137600		L	M	H
Frequency (MHz)				673	680.5	688				
20	PI/2 BPSK	1	1	22.65	22.61	22.59	-3.5	0.0501	0.0497	0.0494
20	QPSK	1	1	22.78	22.84	22.80	-3.5	0.0516	0.0524	0.0519
20	QPSK	1	53	22.60	22.49	22.51		0.0495	0.0483	0.0485
20	QPSK	1	104	22.53	22.51	22.49		0.0488	0.0485	0.0483
20	QPSK	50	0	22.36	22.34	22.31	-3.5	0.0469	0.0467	0.0463
20	QPSK	50	28	22.15	22.19	22.22		0.0447	0.0451	0.0454
20	QPSK	50	56	22.31	22.32	22.19		0.0463	0.0465	0.0451
20	QPSK	100	0	22.14	22.13	22.16	-3.5	0.0446	0.0445	0.0448
20	16QAM	1	1	21.85	21.67	21.74		0.0417	0.0400	0.0406
20	64QAM	1	1	20.08	20.09	20.11		0.0277	0.0278	0.0279
20	256QAM	1	1	19.36	19.22	19.25	-3.5	0.0235	0.0228	0.0229
Channel				134100	136100	138100	Gain	L	M	H
Frequency (MHz)				670.5	680.5	690.5				
15	QPSK	1	1	22.65	22.61	22.53	-3.5	0.0501	0.0497	0.0488
15	16QAM	1	1	21.54	21.39	21.54	-3.5	0.0388	0.0375	0.0388
Channel				133600	136100	138600	Gain	L	M	H
Frequency (MHz)				668	680.5	693				
10	QPSK	1	1	22.60	22.69	22.59	-3.5	0.0495	0.0506	0.0494
10	16QAM	1	1	21.69	21.33	21.65	-3.5	0.0402	0.0370	0.0398
Channel				133100	136100	139100	Gain	L	M	H
Frequency (MHz)				665.5	680.5	695.5				
5	QPSK	1	1	21.59	22.71	22.45	-3.5	0.0393	0.0508	0.0479
5	16QAM	1	1	21.63	21.38	21.37	-3.5	0.0396	0.0374	0.0373



FR1 n5

Peak-to-Average Ratio

Mode	FR1 n5 / 20MHz / DFT-S OFDM				
Mod.	PI/2 BPSK	QPSK	16QAM	64QAM	Limit: 13dB
RB Size	Full RB	Full RB	Full RB	Full RB	Result
Middle CH	4.35	4.38	5.54	5.88	PASS
Mode	FR1 n5 / 20MHz / DFT-S OFDM				
Mod.	256QAM				Limit: 13dB
RB Size	Full RB				Result
Middle CH	6.26				PASS



FR1 n5 / 20MHz / DFT-S OFDM / Middle Channel / Full RB

PI/2 BPSK

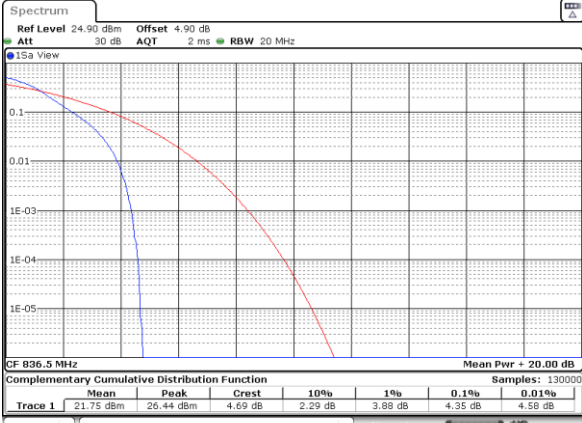

Date: 1.APR.2021 16:21:54

QPSK

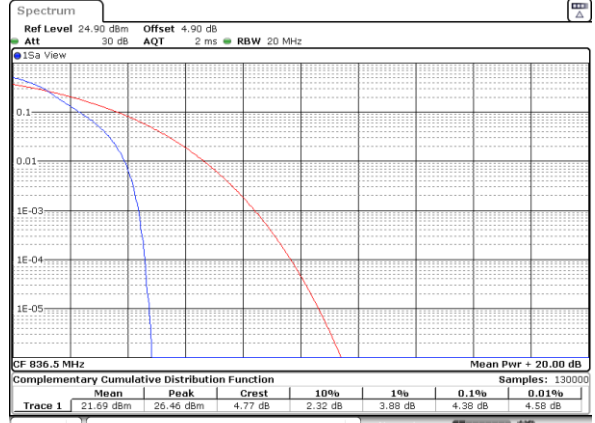

Date: 1.APR.2021 16:22:03

16QAM

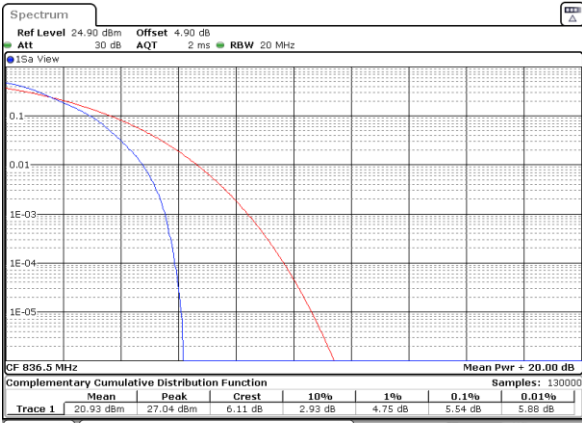

Date: 1.APR.2021 16:22:14

64QAM

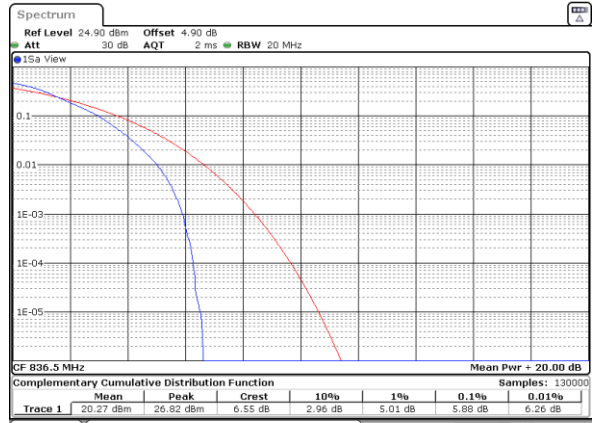

Date: 1.APR.2021 16:22:25

256QAM

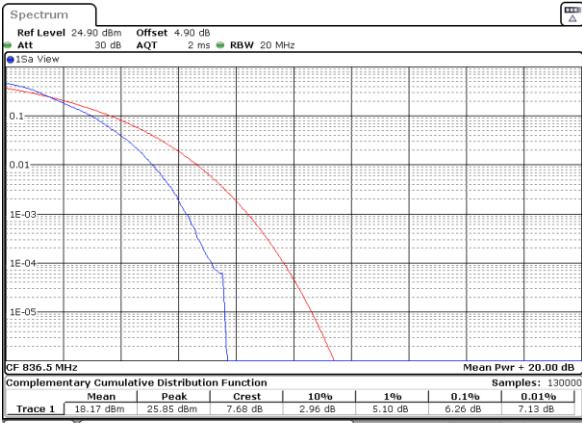

Date: 1.APR.2021 16:22:35



26dB Bandwidth

Mode	FR1 n5 : 26dB BW(MHz) / CP OFDM					
BW	20MHz					
Mod.	QPSK		16QAM			
Middle CH	21.179		21.099			

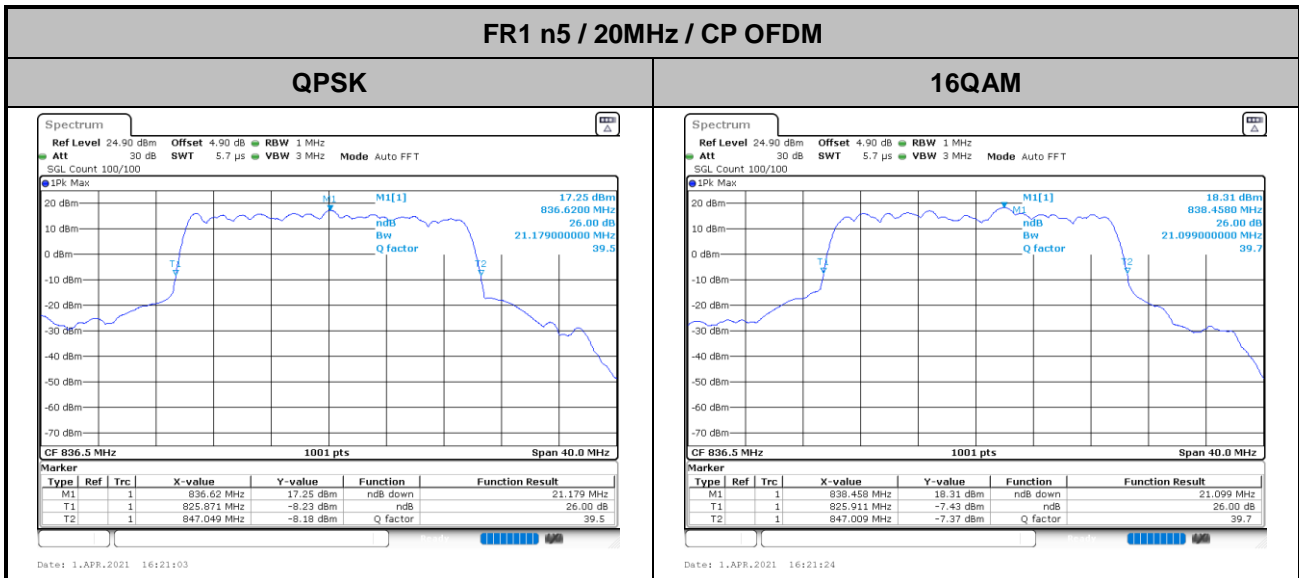



Occupied Bandwidth

Mode	FR1 n5 : 99%OBW (MHz) / CP OFDM						
BW	20MHz						
Mod.			QPSK	16QAM			
Middle CH			19.301	19.421			

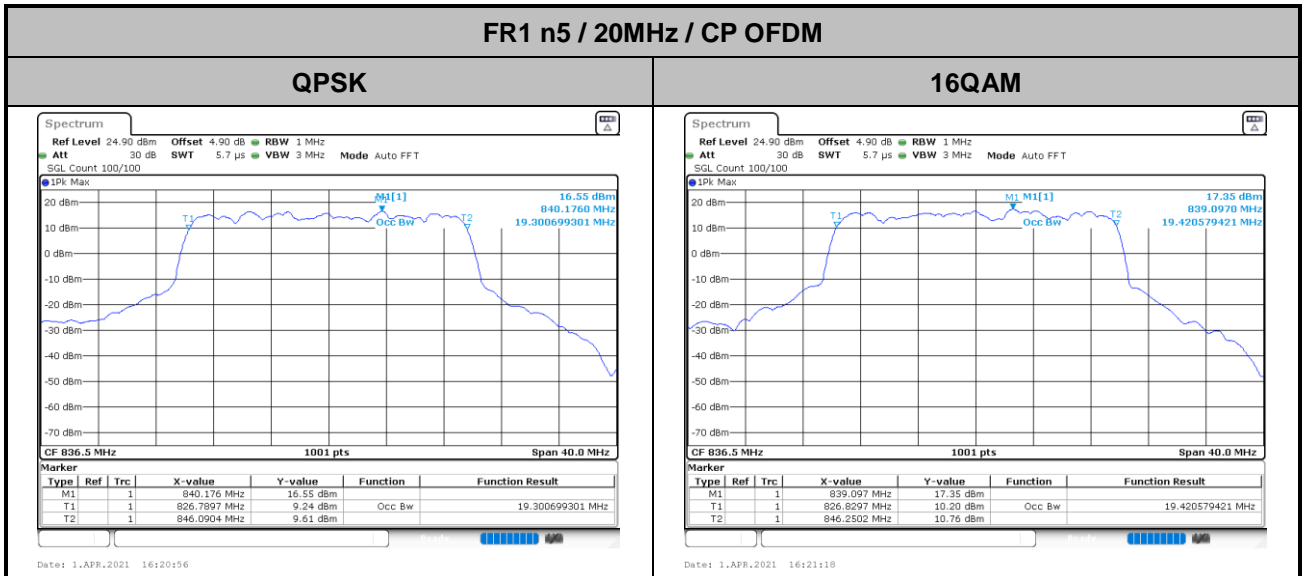



Conducted Band Edge



FR1 n5 / 5MHz / DFT-S OFDM / PI/2 BPSK

Lowest Band Edge / 1RB0

Highest Band Edge / 1RBmax

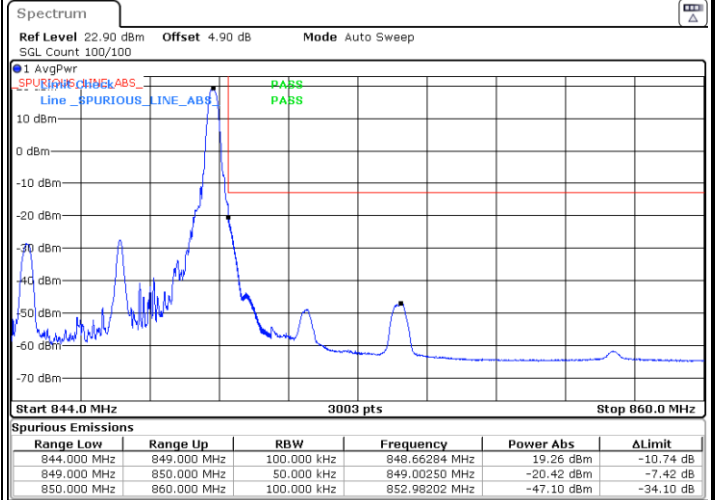
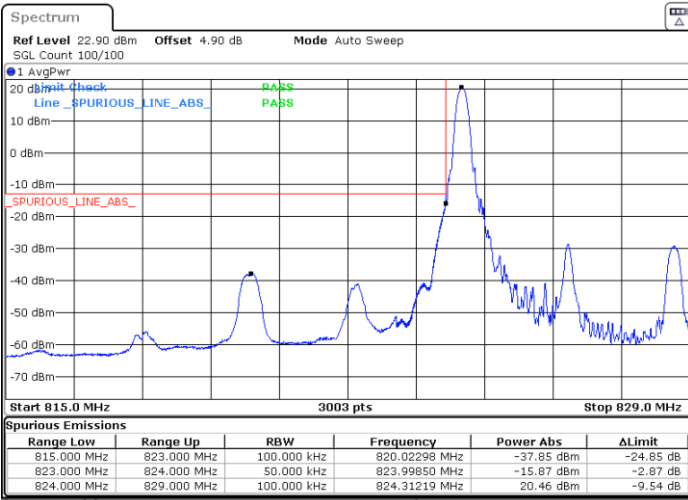

Date: 1.APR.2021 14:54:32

Date: 1.APR.2021 15:02:13

Lowest Band Edge / Full RB

Highest Band Edge / Full RB

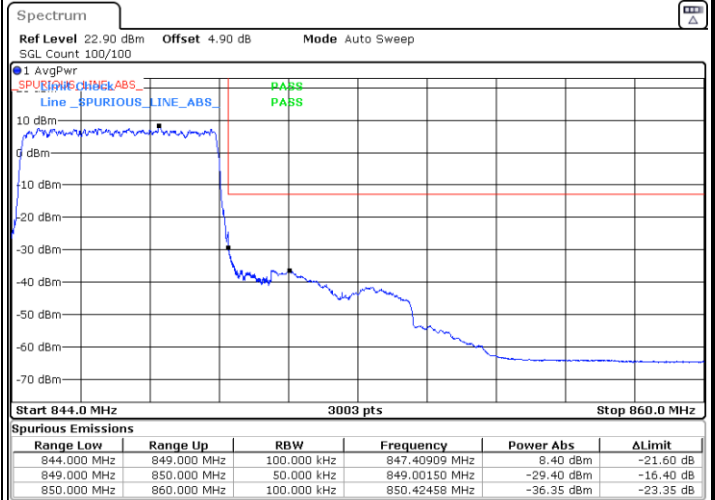
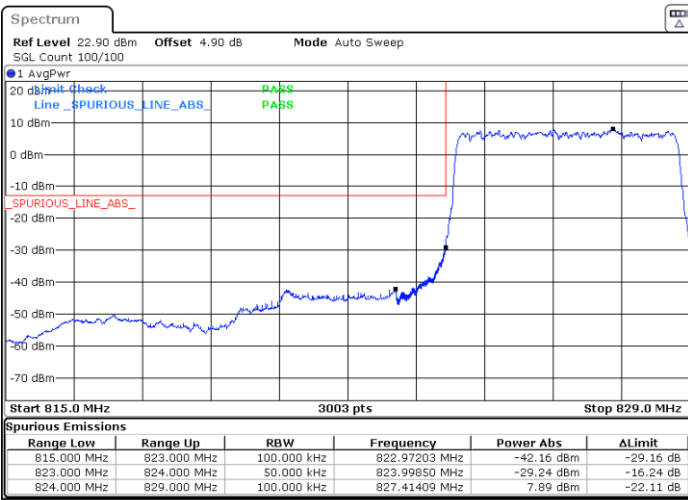

Date: 1.APR.2021 14:57:58

Date: 1.APR.2021 15:08:50



FR1 n5 / 5MHz / DFT-S OFDM / QPSK

Lowest Band Edge / 1RB0

Highest Band Edge / 1RBmax

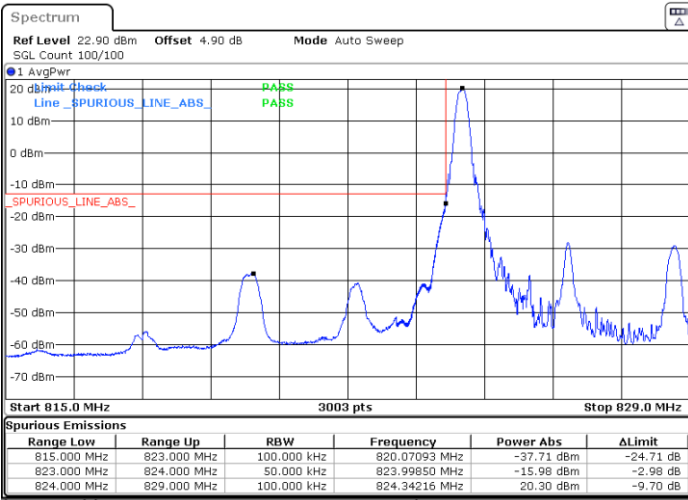

Date: 1.APR.2021 14:55:08

Date: 1.APR.2021 15:03:04

Lowest Band Edge / Full RB

Highest Band Edge / Full RB

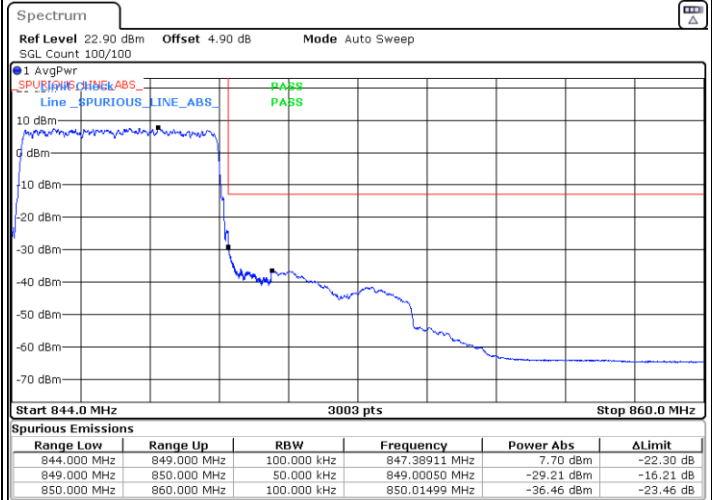
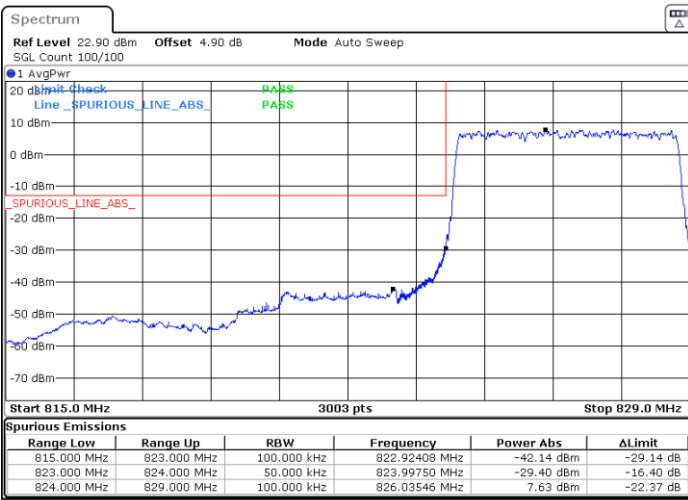

Date: 1.APR.2021 14:58:33

Date: 1.APR.2021 15:09:35



FR1 n5 / 5MHz / DFT-S OFDM / 16Q

Lowest Band Edge / 1RB0

Highest Band Edge / 1RBmax

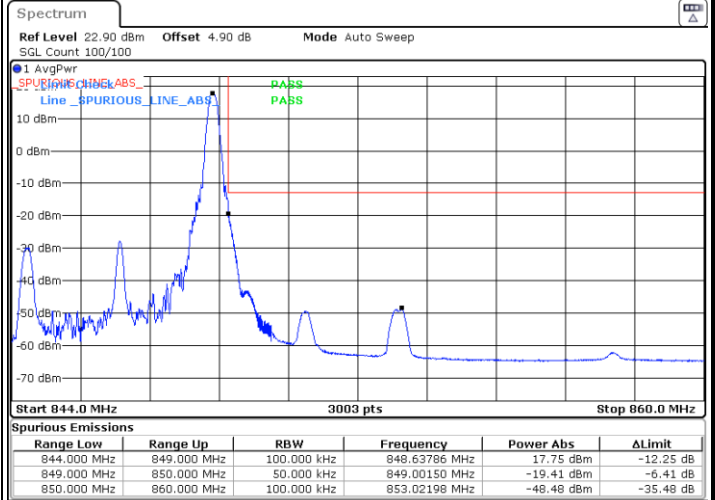
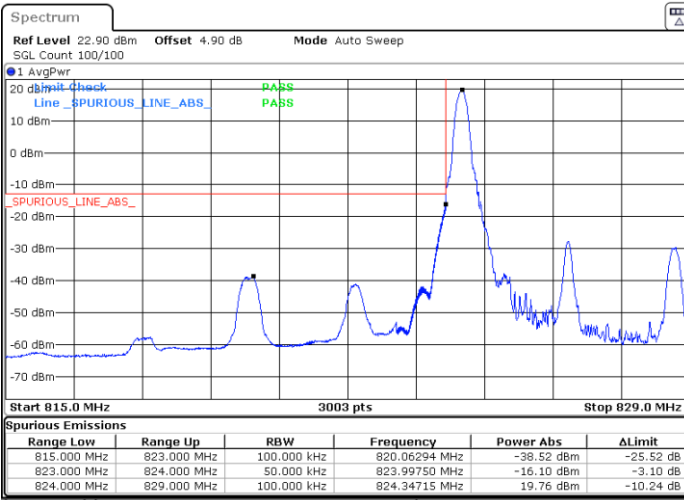

Date: 1.APR.2021 14:55:46

Date: 1.APR.2021 15:03:57

Lowest Band Edge / Full RB

Highest Band Edge / Full RB

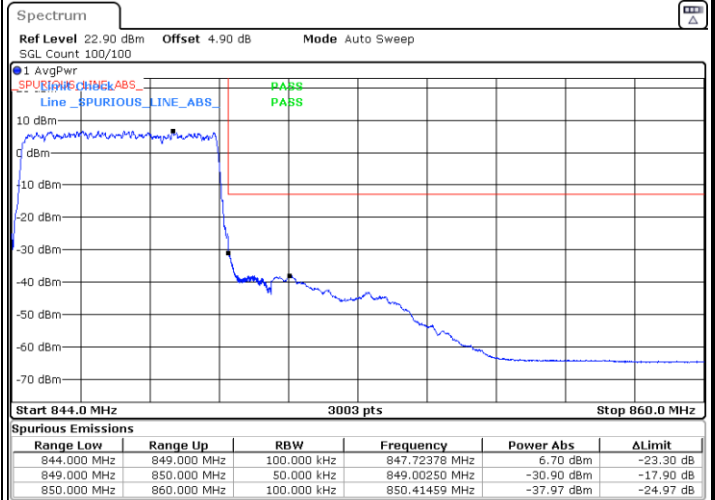
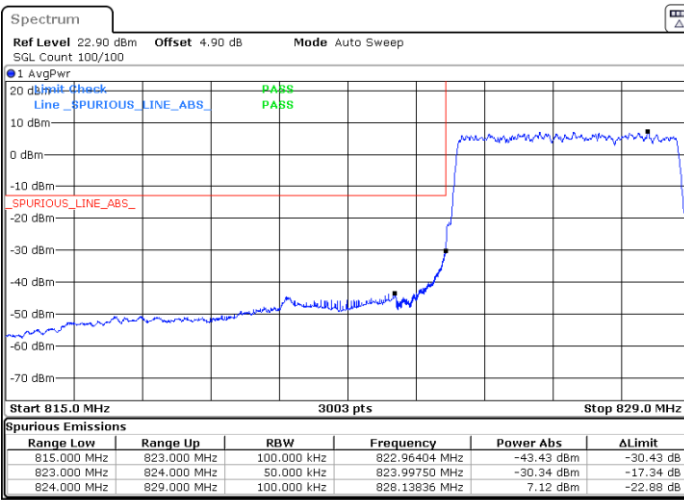

Date: 1.APR.2021 14:59:14

Date: 1.APR.2021 15:10:18



FR1 n5 / 5MHz / DFT-S OFDM / 64Q

Lowest Band Edge / 1RB0

Highest Band Edge / 1RBmax

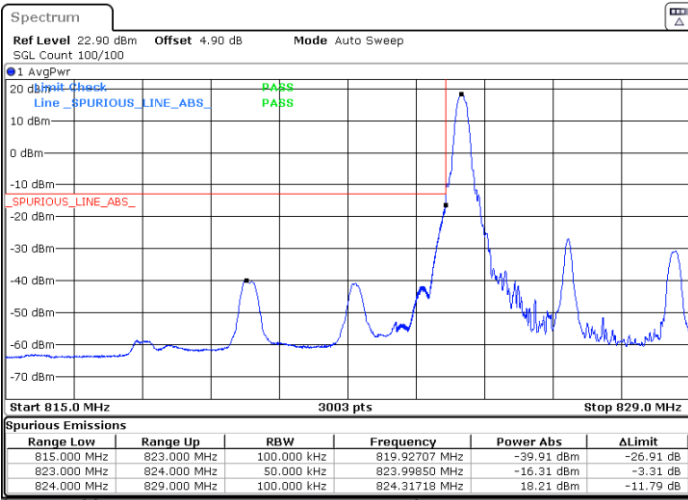

Date: 1.APR.2021 14:56:27

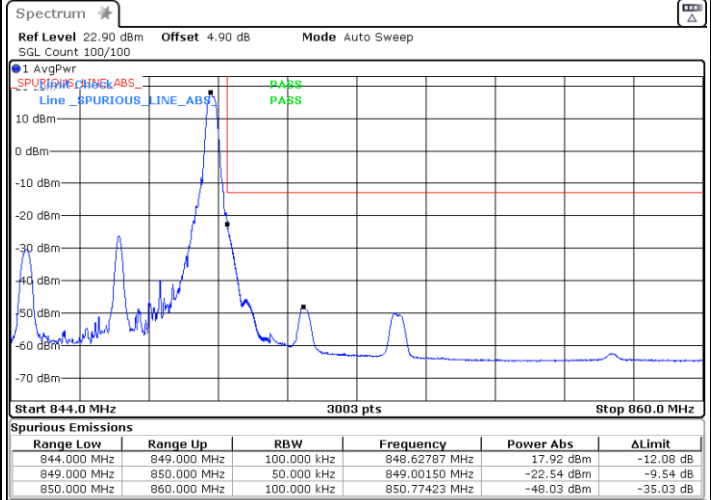

Date: 1.APR.2021 15:05:19

Lowest Band Edge / Full RB

Highest Band Edge / Full RB

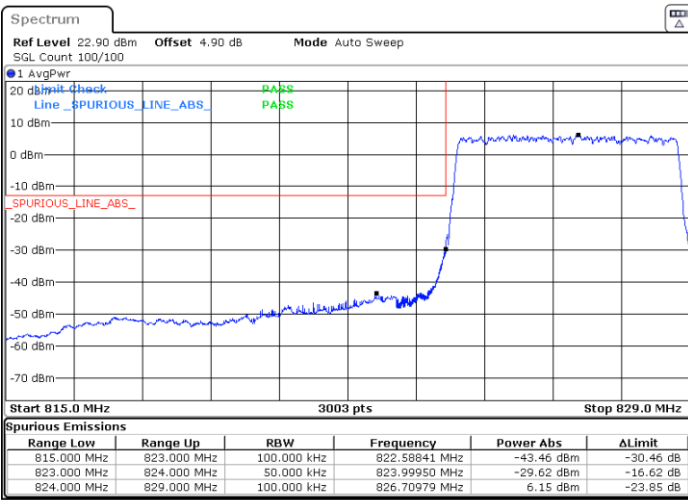

Date: 1.APR.2021 14:59:53

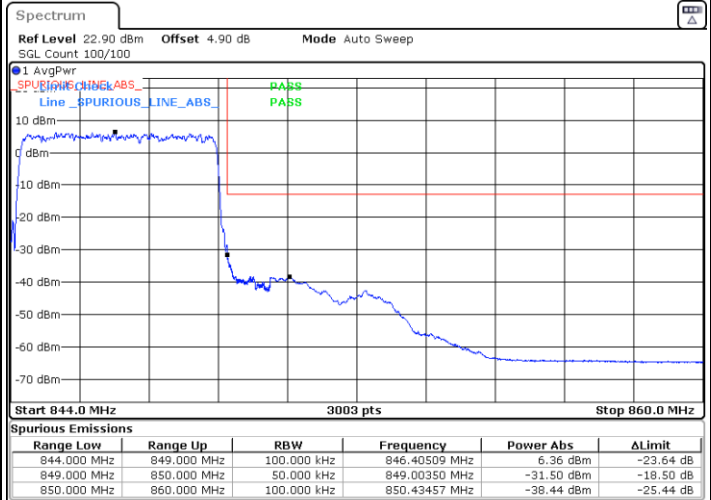

Date: 1.APR.2021 15:11:00



FR1 n5 / 5MHz / DFT-S OFDM / 256Q

Lowest Band Edge / 1RB0

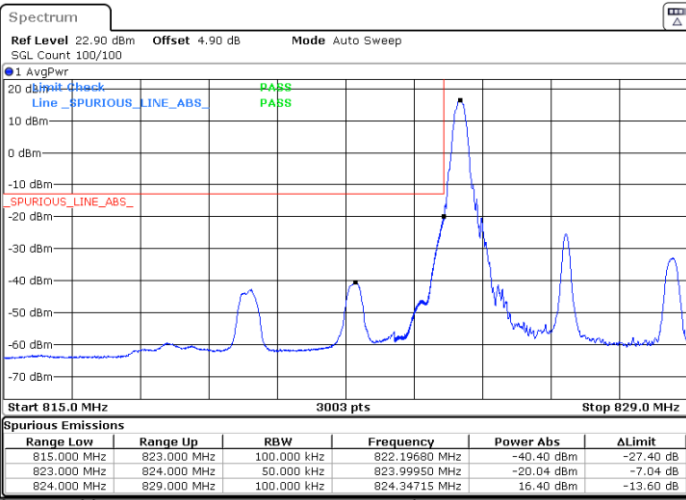

Date: 1.APR.2021 14:57:09

Highest Band Edge / 1RBmax

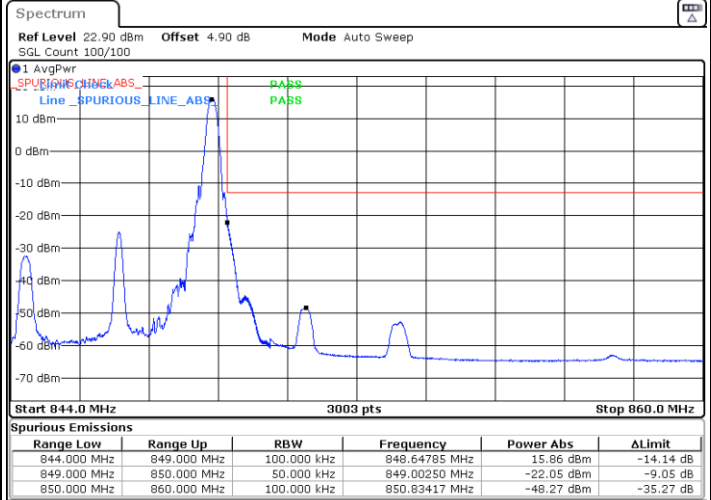

Date: 1.APR.2021 15:07:30

Lowest Band Edge / Full RB

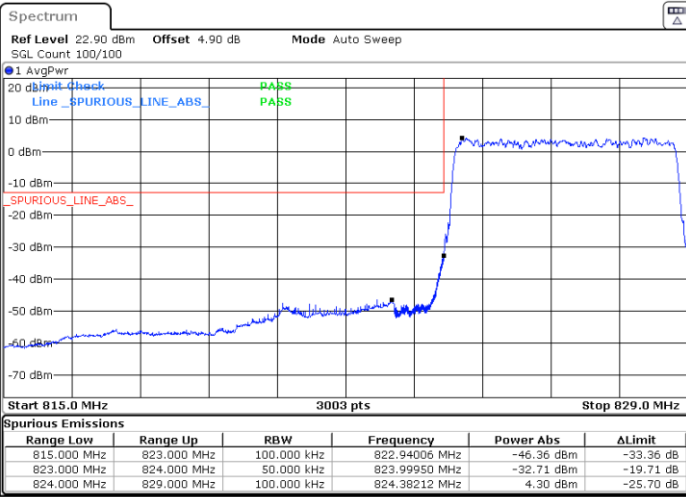

Date: 1.APR.2021 15:00:35

Highest Band Edge / Full RB

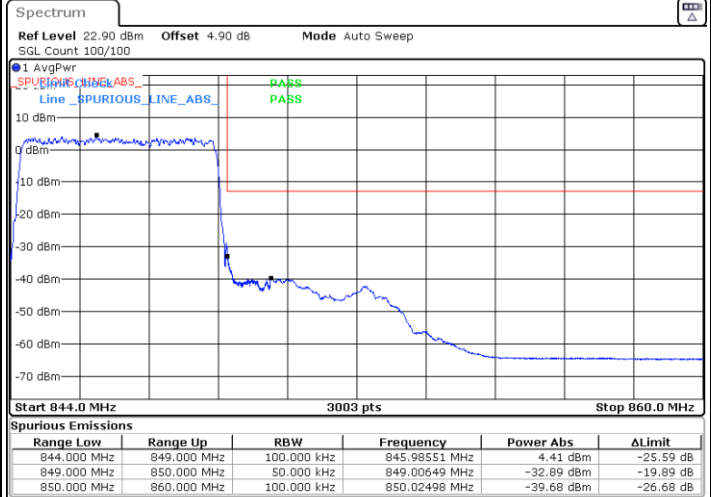

Date: 1.APR.2021 15:11:42



FR1 n5 / 10MHz / DFT-s-OFDM / PI/2 BPSK

Lowest Band Edge / 1RB0

Highest Band Edge / 1RBmax

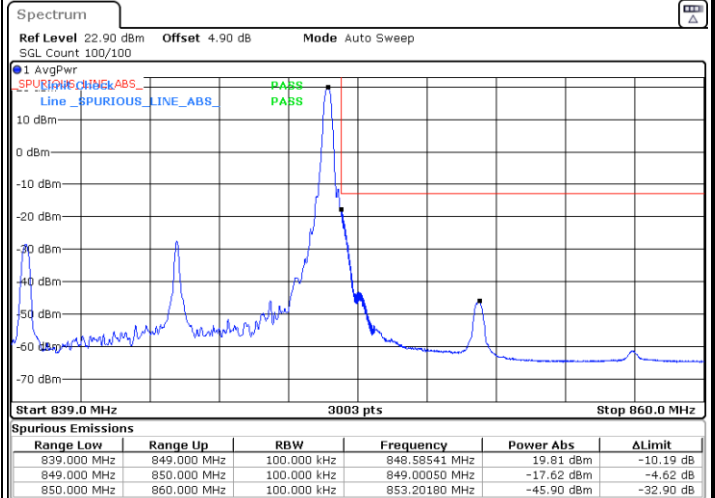
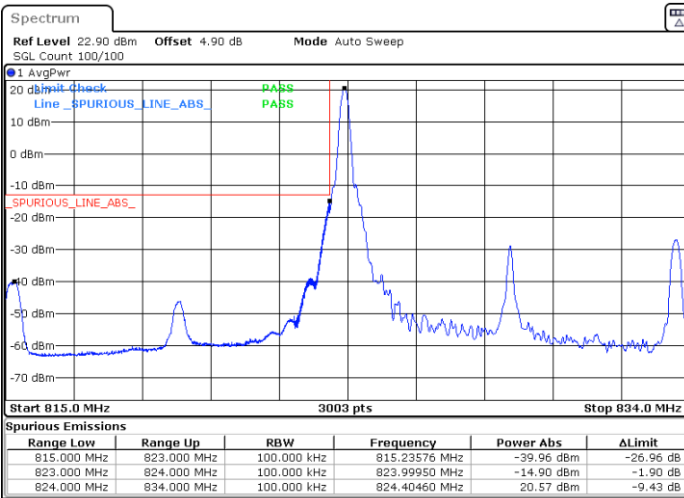

Date: 1.APR.2021 15:14:19

Date: 1.APR.2021 15:21:36

Lowest Band Edge / Full RB

Highest Band Edge / Full RB

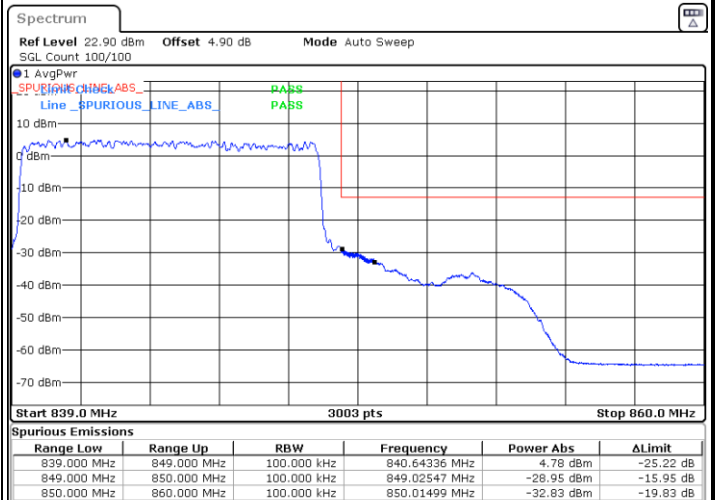
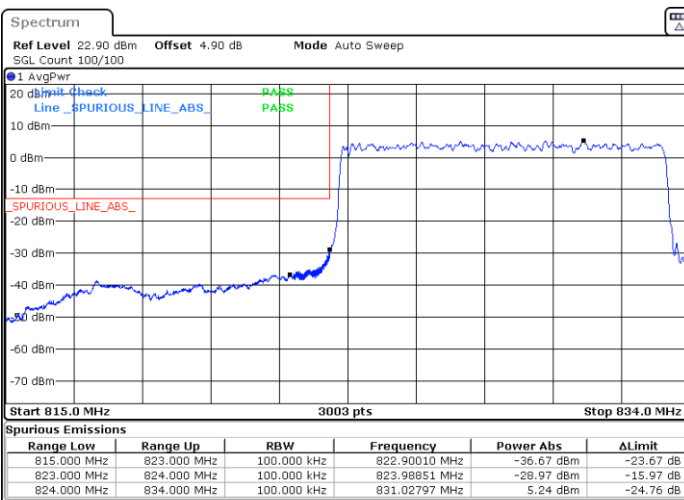

Date: 1.APR.2021 15:17:28

Date: 1.APR.2021 15:26:08



FR1 n5 / 10MHz / DFT-s-OFDM / QPSK

Lowest Band Edge / 1RB0

Highest Band Edge / 1RBmax

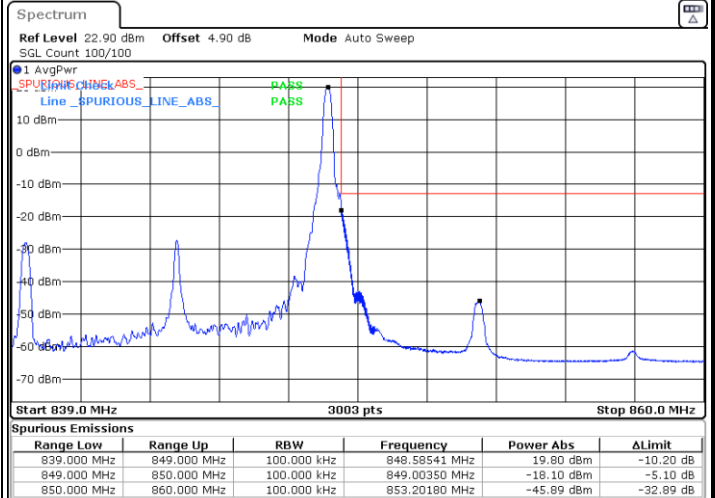
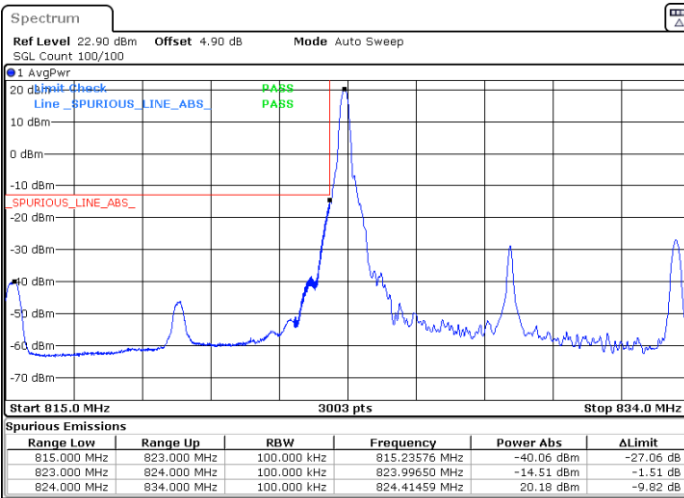

Date: 1.APR.2021 15:14:52

Date: 1.APR.2021 15:22:29

Lowest Band Edge / Full RB

Highest Band Edge / Full RB

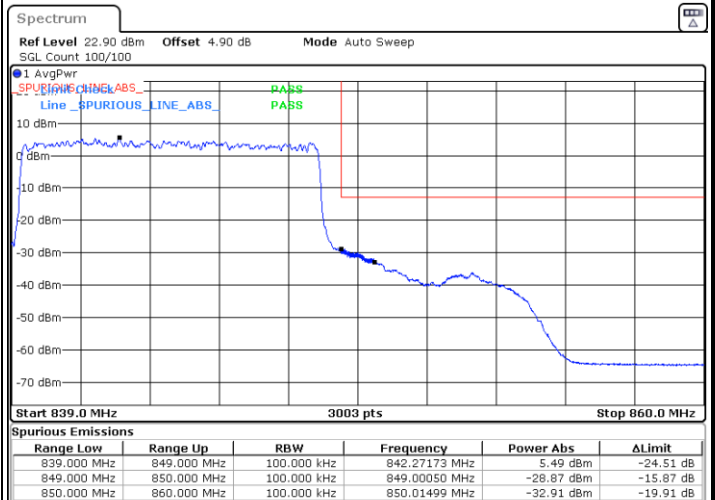
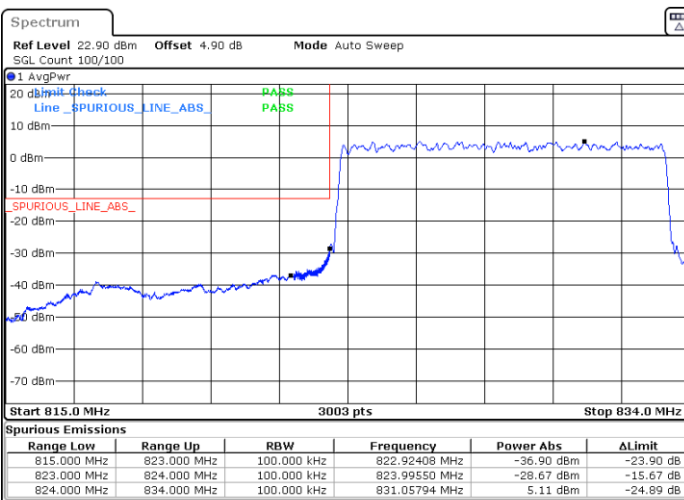

Date: 1.APR.2021 15:18:01

Date: 1.APR.2021 15:26:49



FR1 n5 / 10MHz / DFT-s-OFDM / 16QAM

Lowest Band Edge / 1RB0

Highest Band Edge / 1RBmax

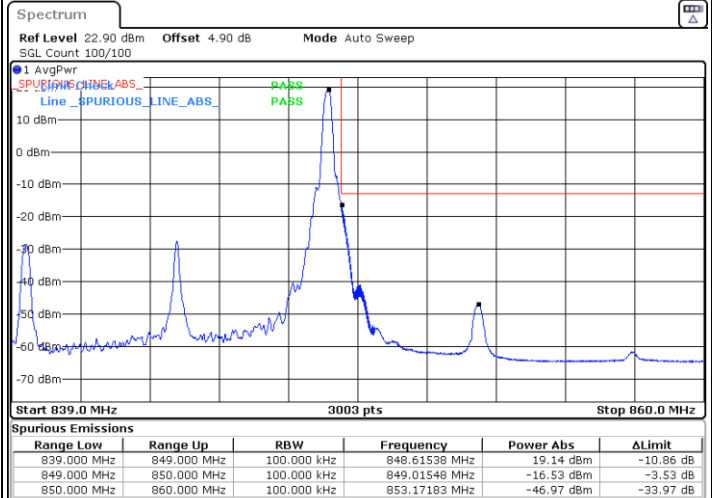
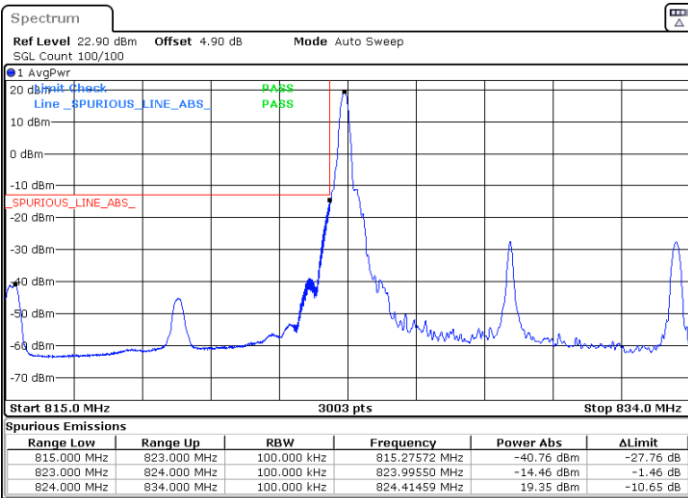

Date: 1.APR.2021 15:15:26

Date: 1.APR.2021 15:23:16

Lowest Band Edge / Full RB

Highest Band Edge / Full RB

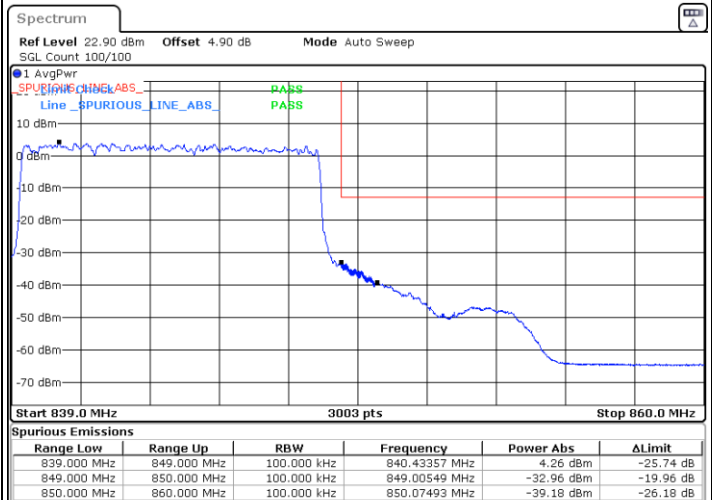
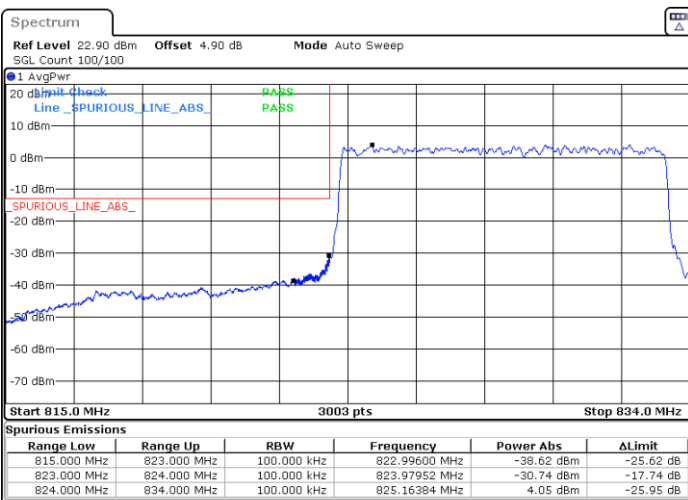

Date: 1.APR.2021 15:18:47

Date: 1.APR.2021 15:27:31



FR1 n5 / 10MHz / DFT-s-OFDM / 64QAM

Lowest Band Edge / 1RB0

Highest Band Edge / 1RBmax

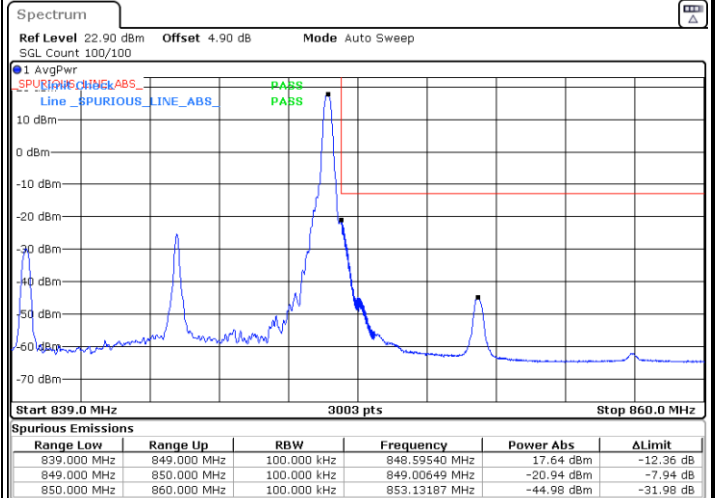
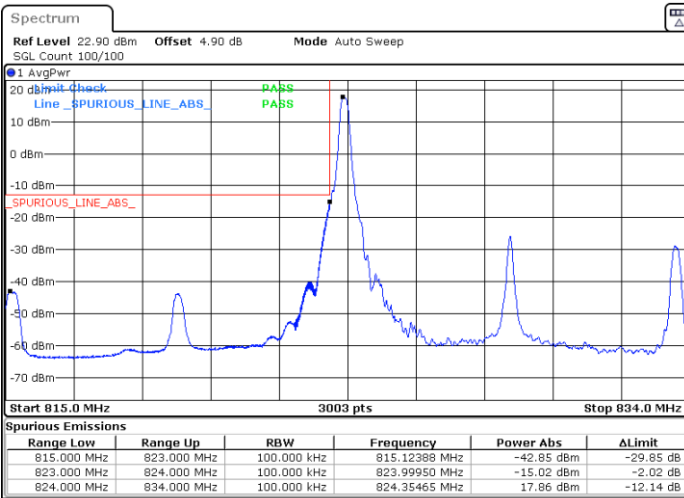

Date: 1.APR.2021 15:16:02

Date: 1.APR.2021 15:24:08

Lowest Band Edge / Full RB

Highest Band Edge / Full RB

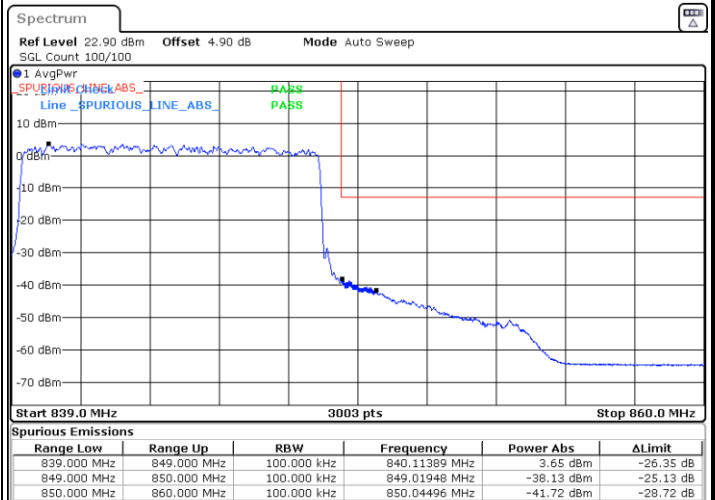
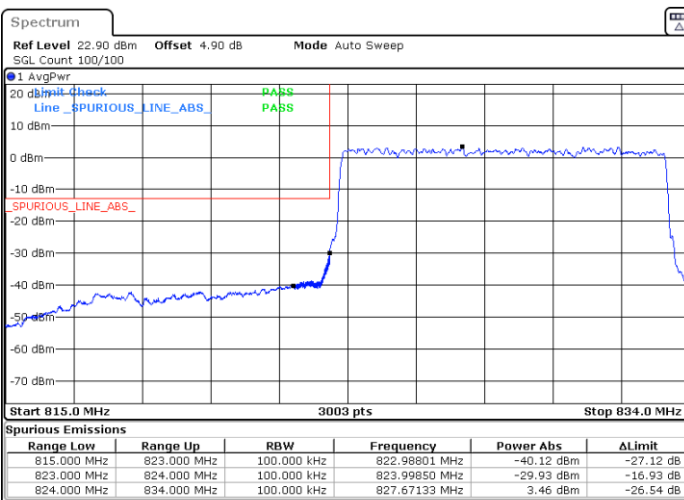

Date: 1.APR.2021 15:19:21

Date: 1.APR.2021 15:28:08



FR1 n5 / 10MHz / DFT-s-OFDM / 256QAM

Lowest Band Edge / 1RB0

Highest Band Edge / 1RBmax

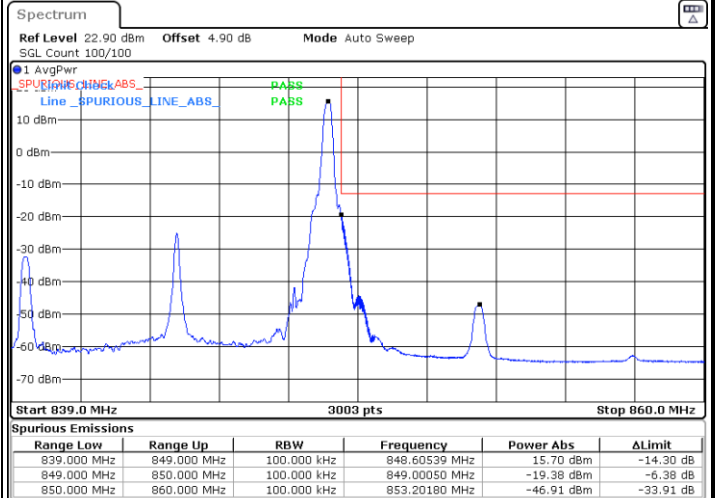
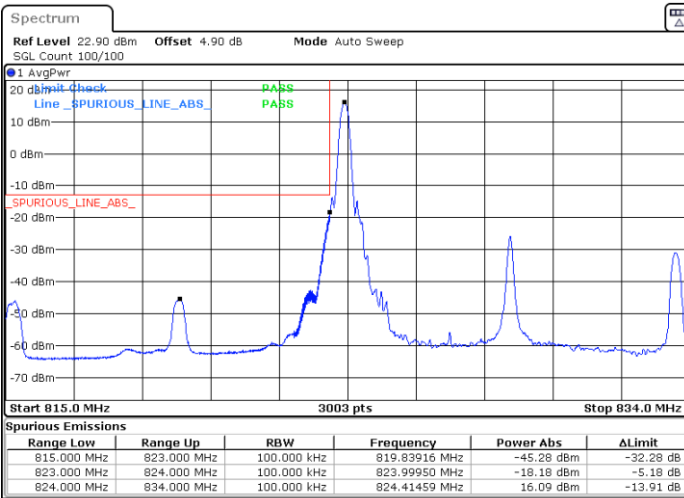

Date: 1.APR.2021 15:16:37

Date: 1.APR.2021 15:24:49

Lowest Band Edge / Full RB

Highest Band Edge / Full RB

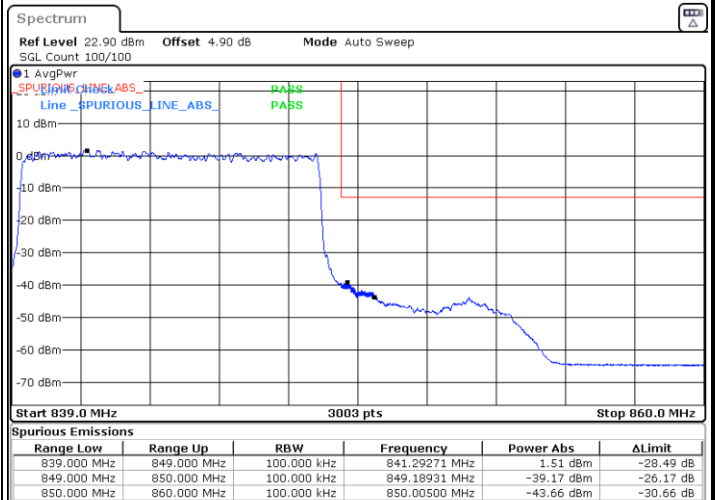
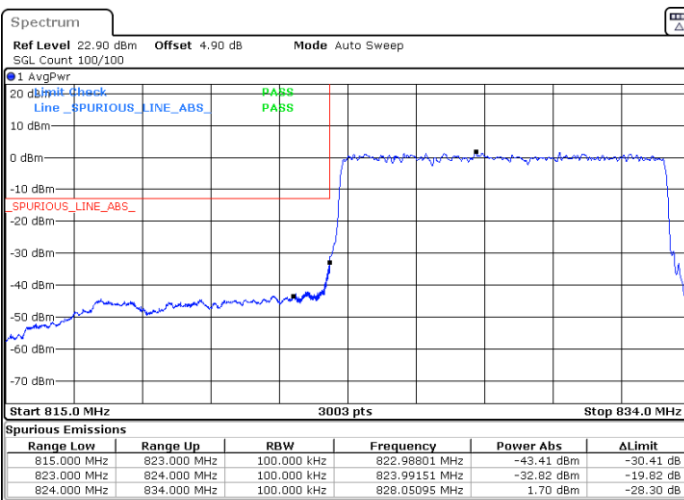

Date: 1.APR.2021 15:20:06

Date: 1.APR.2021 15:28:53



FR1 n5 / 15MHz / DFT-s-OFDM / PI/2 BPSK

Lowest Band Edge / 1RB0

Highest Band Edge / 1RBmax

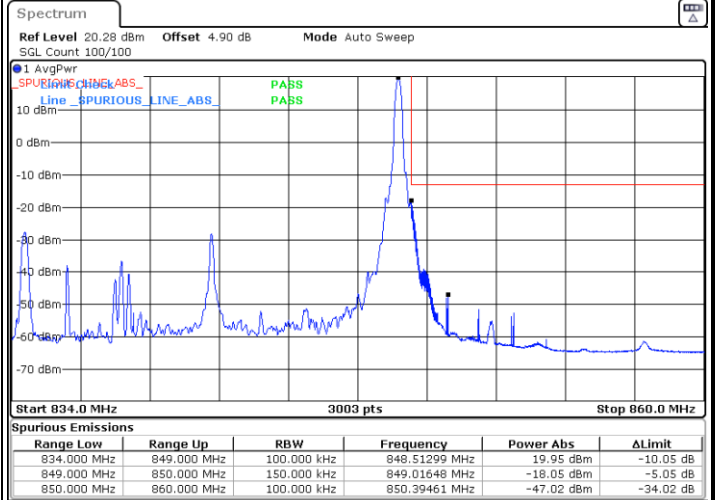
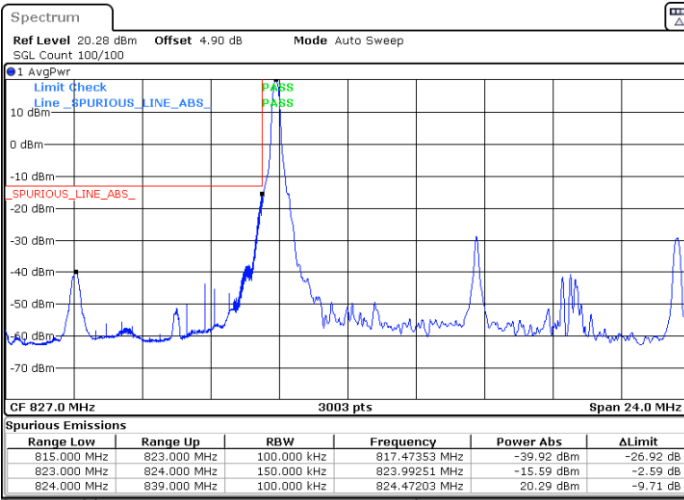

Date: 1.APR.2021 15:34:20

Date: 1.APR.2021 15:37:45

Lowest Band Edge / Full RB

Highest Band Edge / Full RB

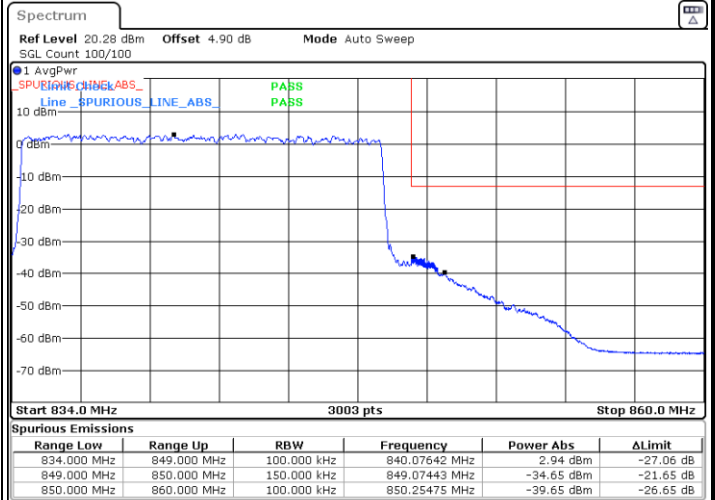
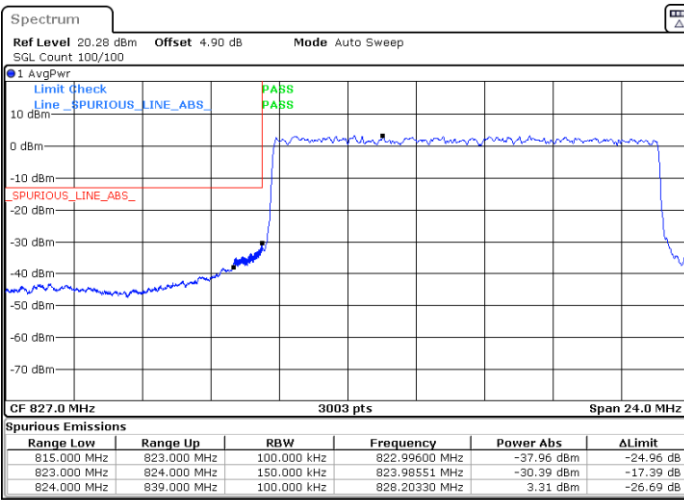

Date: 1.APR.2021 15:31:16

Date: 1.APR.2021 15:41:06



FR1 n5 / 15MHz / DFT-s-OFDM / QPSK

Lowest Band Edge / 1RB0

Highest Band Edge / 1RBmax

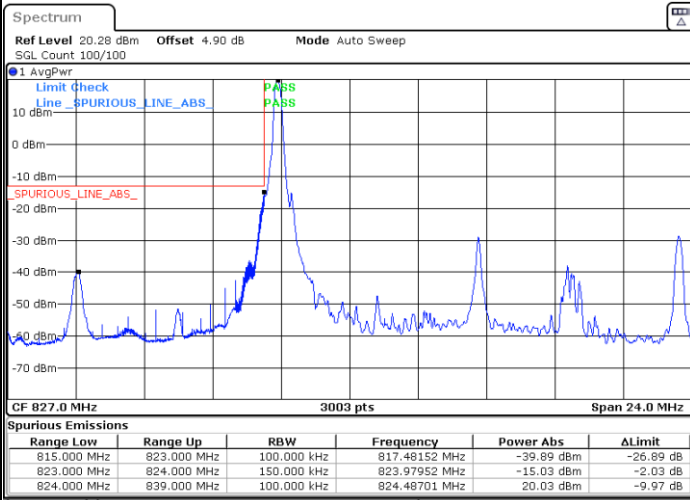

Date: 1.APR.2021 15:34:55

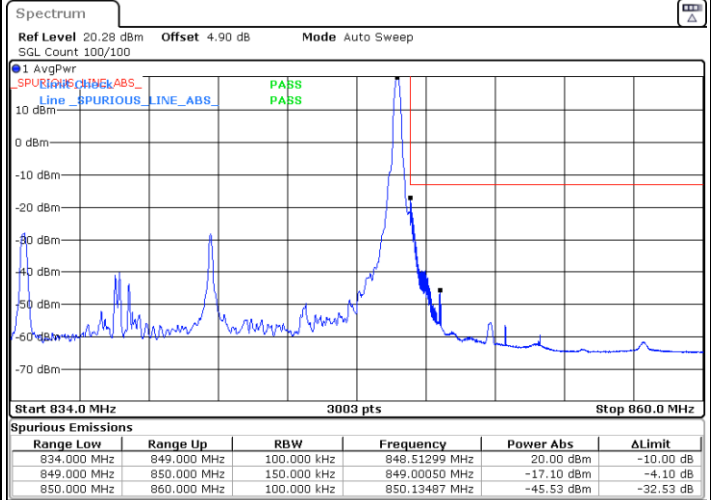

Date: 1.APR.2021 15:38:26

Lowest Band Edge / Full RB

Highest Band Edge / Full RB

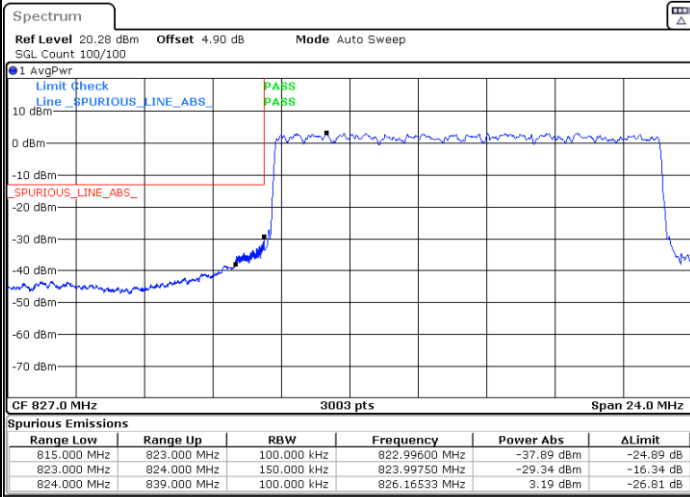

Date: 1.APR.2021 15:31:48

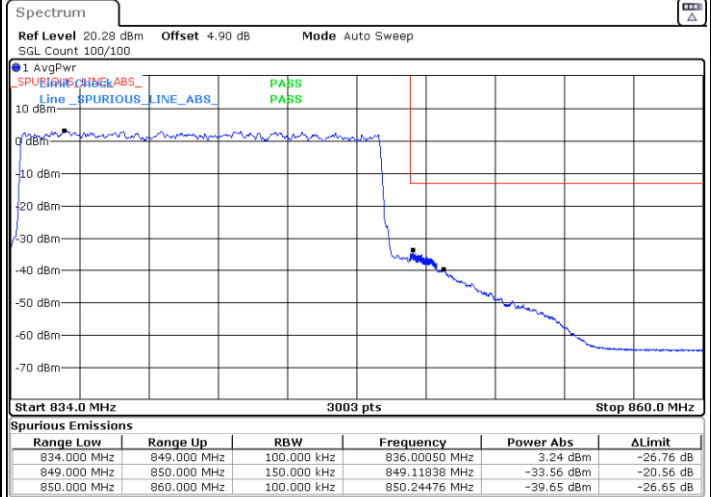

Date: 1.APR.2021 15:41:42



FR1 n5 / 15MHz / DFT-s-OFDM / 16QAM

Lowest Band Edge / 1RB0

Highest Band Edge / 1RBmax

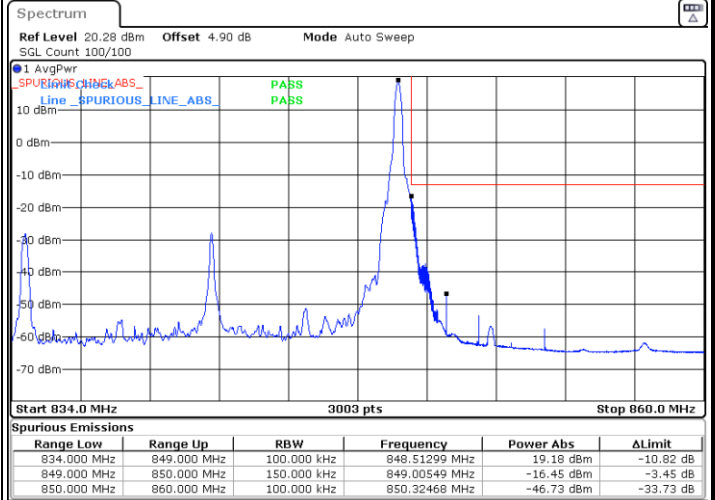
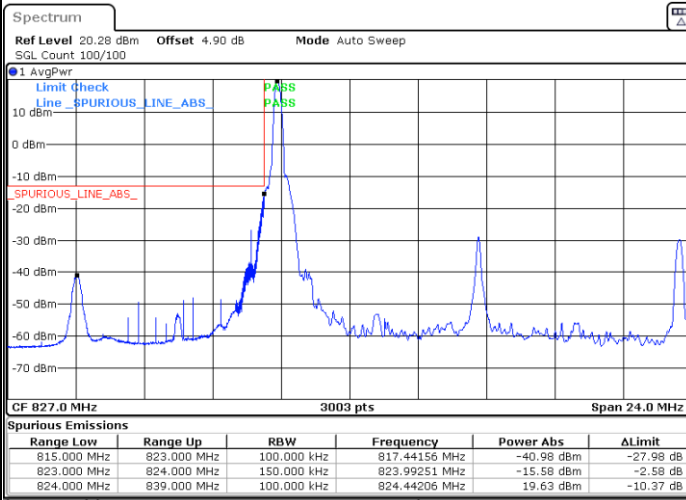

Date: 1.APR.2021 15:35:29

Date: 1.APR.2021 15:39:12

Lowest Band Edge / Full RB

Highest Band Edge / Full RB

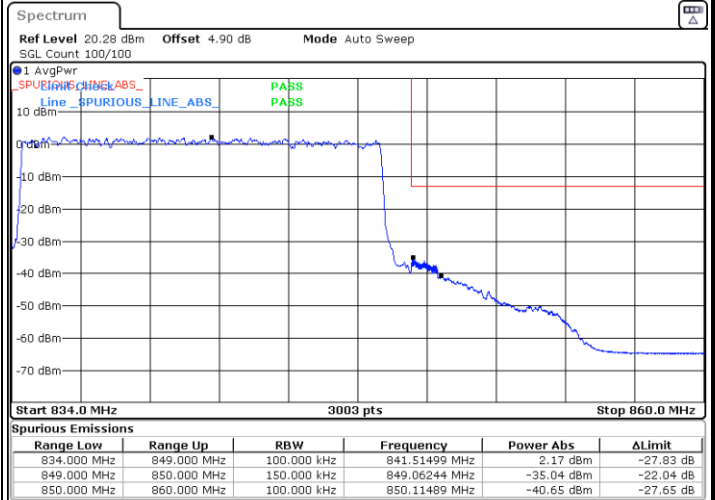
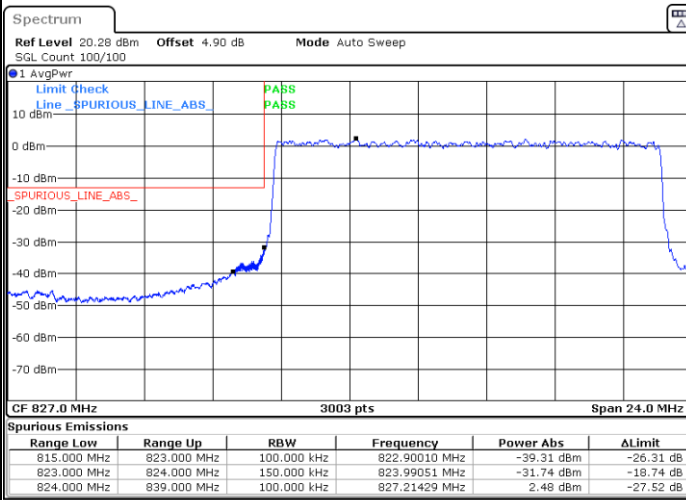

Date: 1.APR.2021 15:32:24

Date: 1.APR.2021 15:42:18



FR1 n5 / 15MHz / DFT-s-OFDM / 64QAM

Lowest Band Edge / 1RB0

Highest Band Edge / 1RBmax

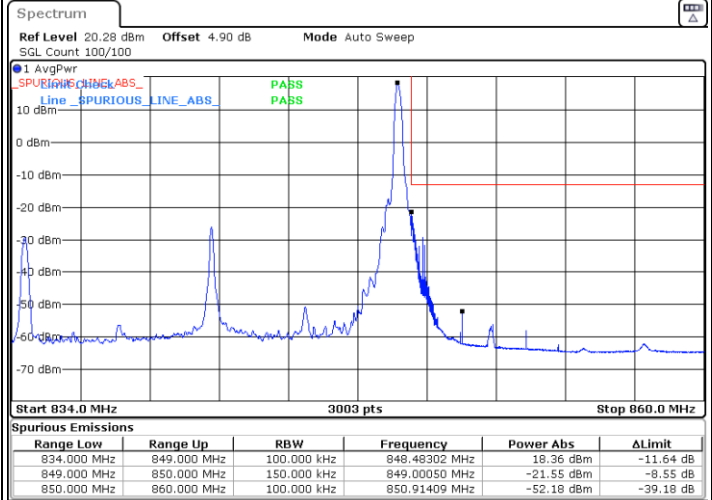
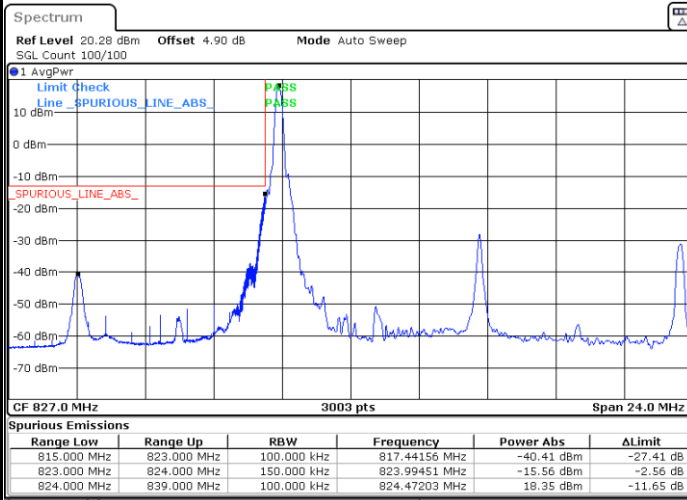

Date: 1.APR.2021 15:36:00

Date: 1.APR.2021 15:39:48

Lowest Band Edge / Full RB

Highest Band Edge / Full RB

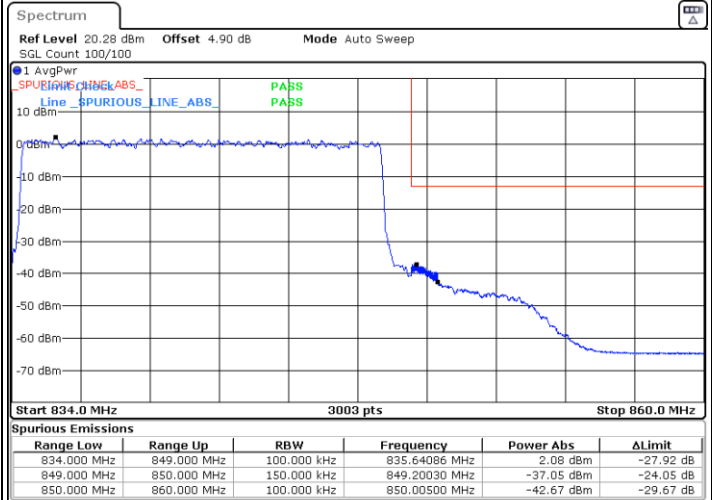
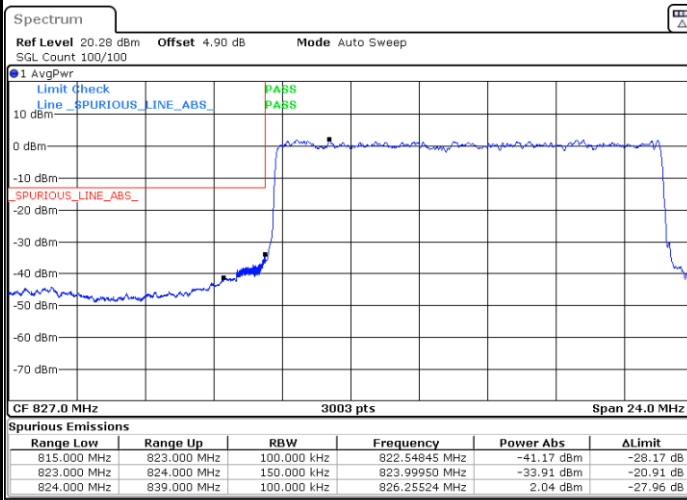

Date: 1.APR.2021 15:33:03

Date: 1.APR.2021 15:42:52



FR1 n5 / 15MHz / DFT-s-OFDM / 256QAM

Lowest Band Edge / 1RB0

Highest Band Edge / 1RBmax

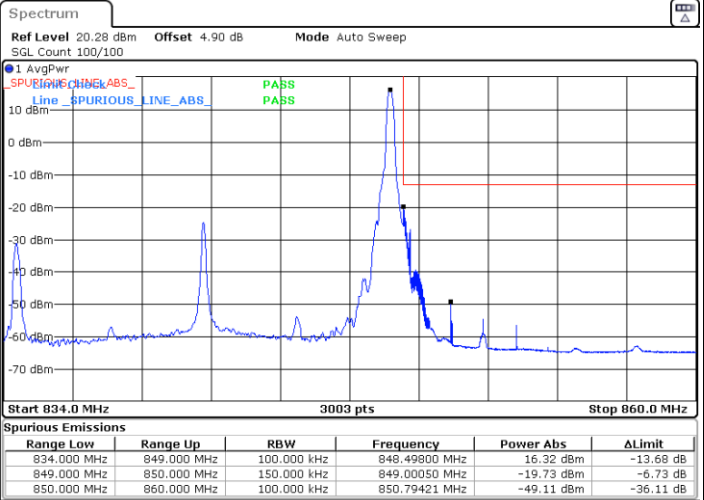
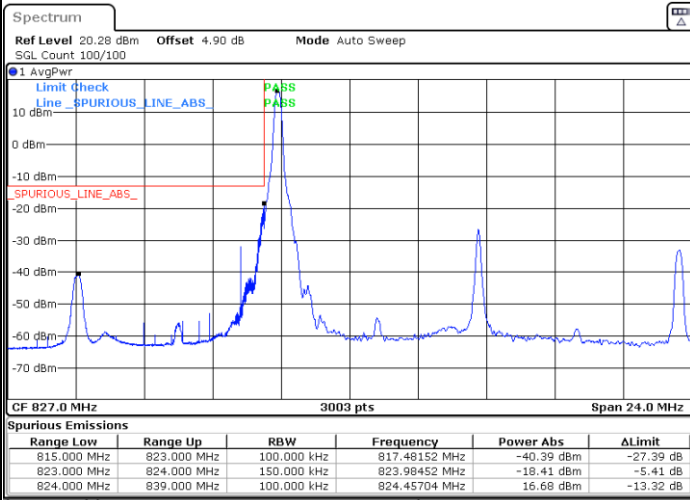

Date: 1.APR.2021 15:36:31

Date: 1.APR.2021 15:40:23

Lowest Band Edge / Full RB

Highest Band Edge / Full RB

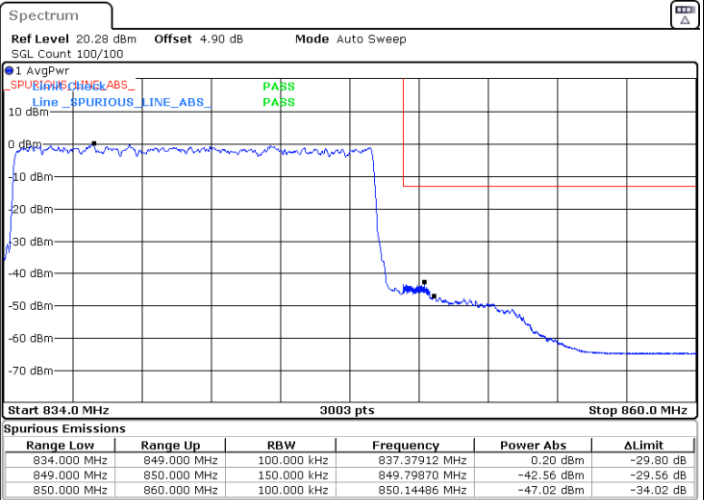
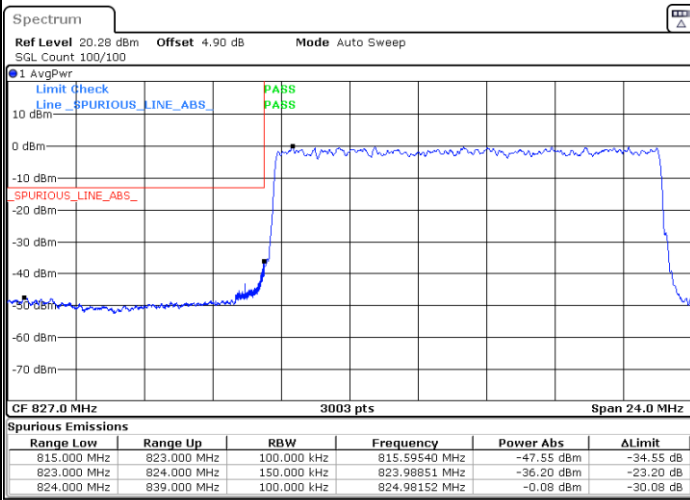

Date: 1.APR.2021 15:33:41

Date: 1.APR.2021 15:43:29



FR1 n5 / 20MHz / DFT-s-OFDM / PI/2 BPSK

Lowest Band Edge / 1RB0

Highest Band Edge / 1RBmax

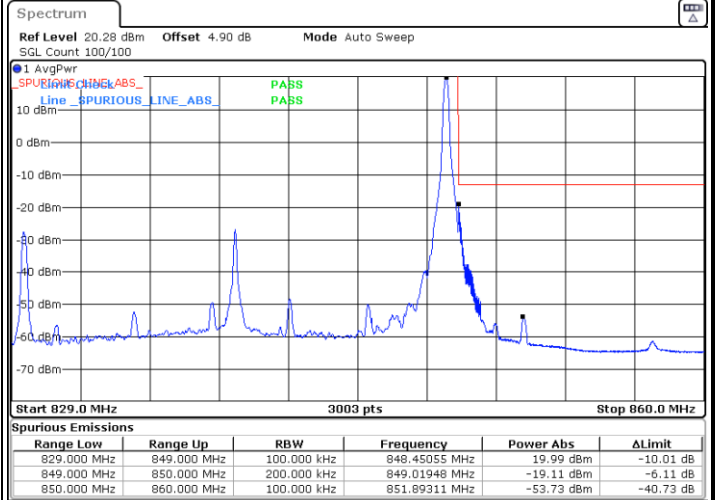
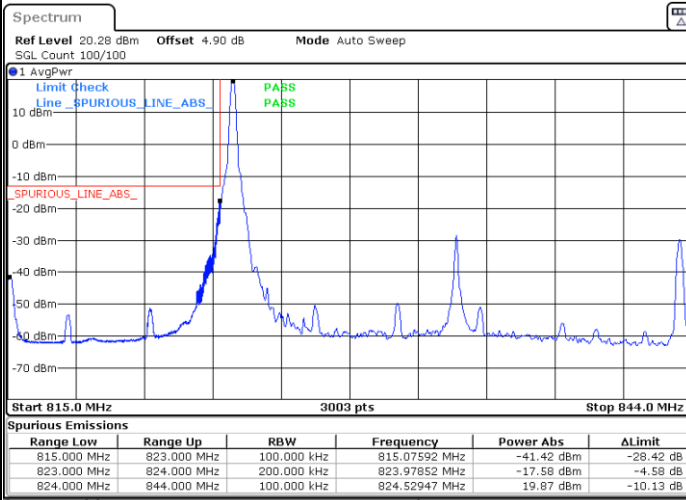

Date: 1.APR.2021 15:47:06

Date: 1.APR.2021 15:57:00

Lowest Band Edge / Full RB

Highest Band Edge / Full RB

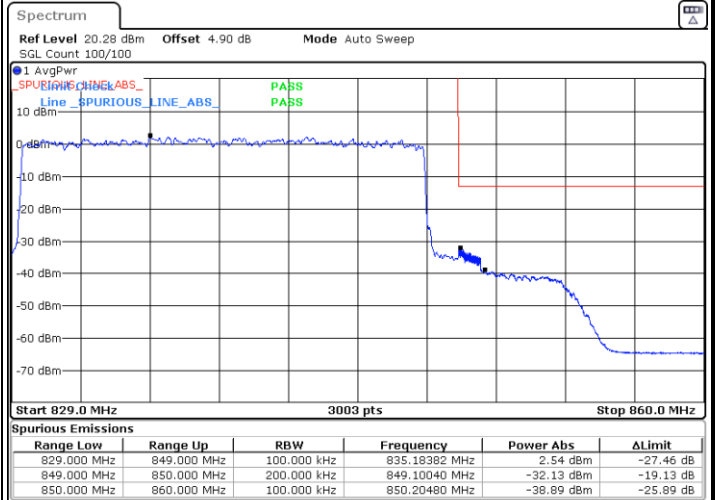
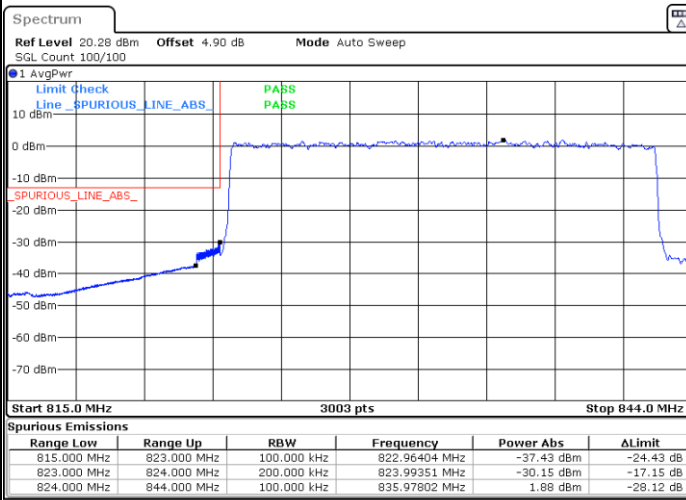

Date: 1.APR.2021 15:50:14

Date: 1.APR.2021 15:53:49



FR1 n5 / 20MHz / DFT-s-OFDM / QPSK

Lowest Band Edge / 1RB0

Highest Band Edge / 1RBmax

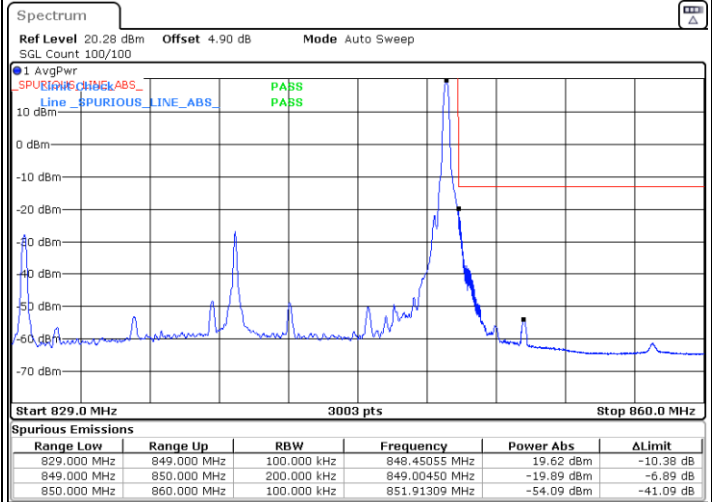
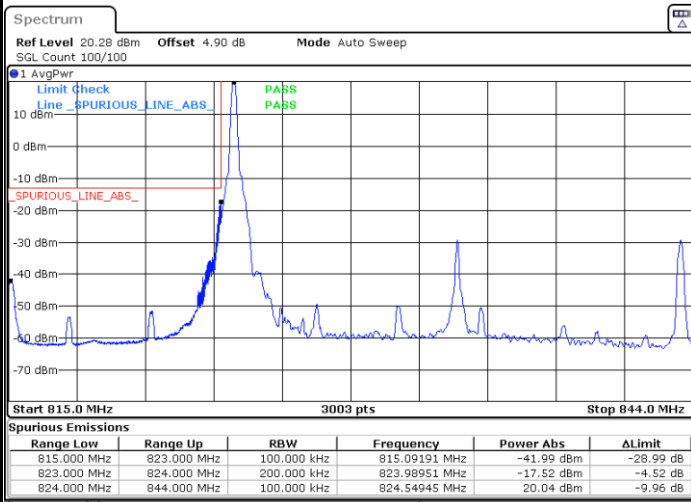

Date: 1.APR.2021 15:47:35

Date: 1.APR.2021 15:57:34

Lowest Band Edge / Full RB

Highest Band Edge / Full RB

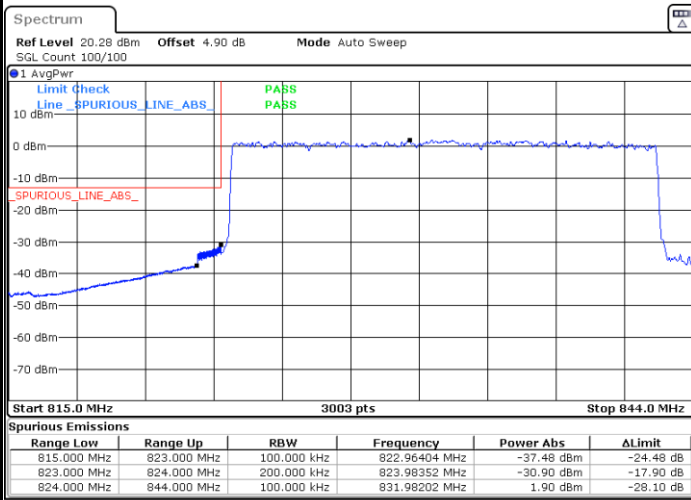

Date: 1.APR.2021 15:51:01

Date: 1.APR.2021 15:54:23



FR1 n5 / 20MHz / DFT-s-OFDM / 16QAM

Lowest Band Edge / 1RB0

Highest Band Edge / 1RBmax

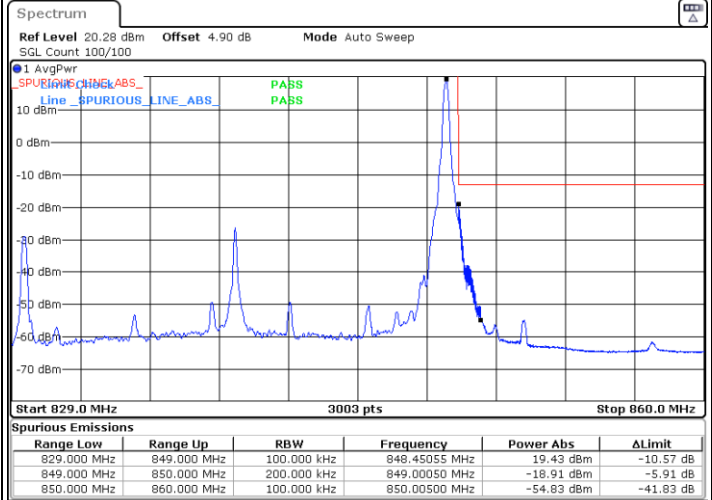
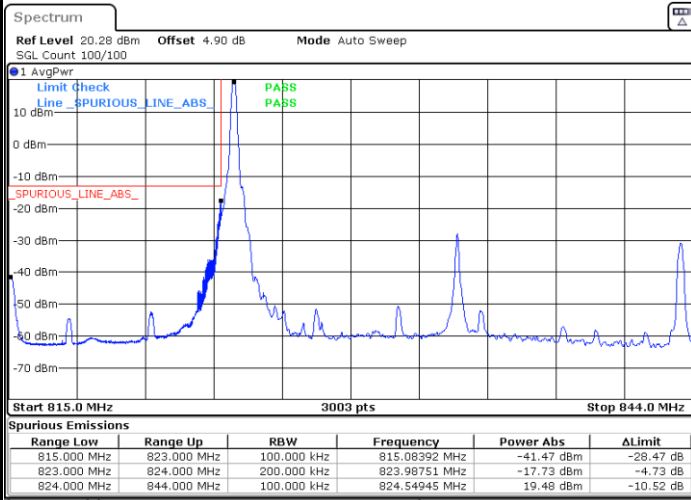

Date: 1.APR.2021 15:48:20

Date: 1.APR.2021 15:58:12

Lowest Band Edge / Full RB

Highest Band Edge / Full RB

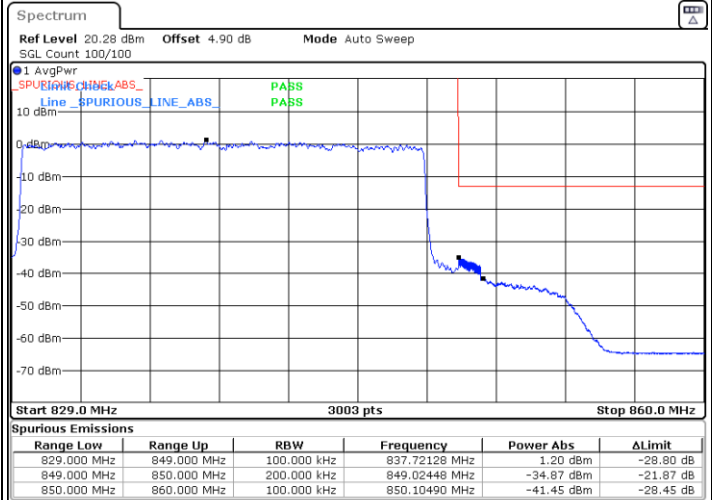
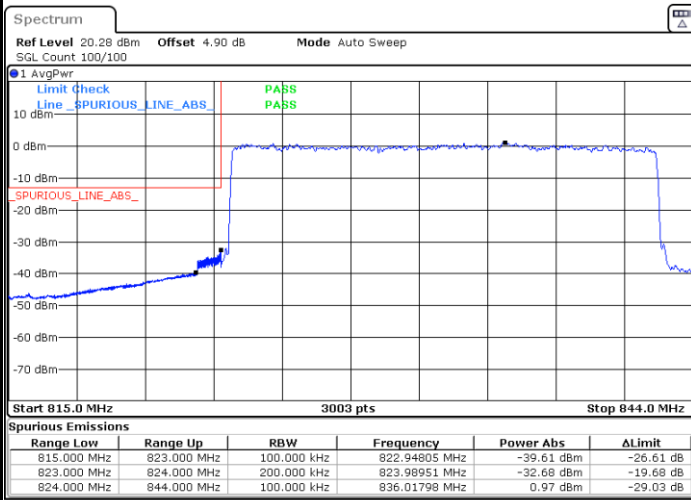

Date: 1.APR.2021 15:51:40

Date: 1.APR.2021 15:54:59



FR1 n5 / 20MHz / DFT-s-OFDM / 64QAM

Lowest Band Edge / 1RB0

Highest Band Edge / 1RBmax

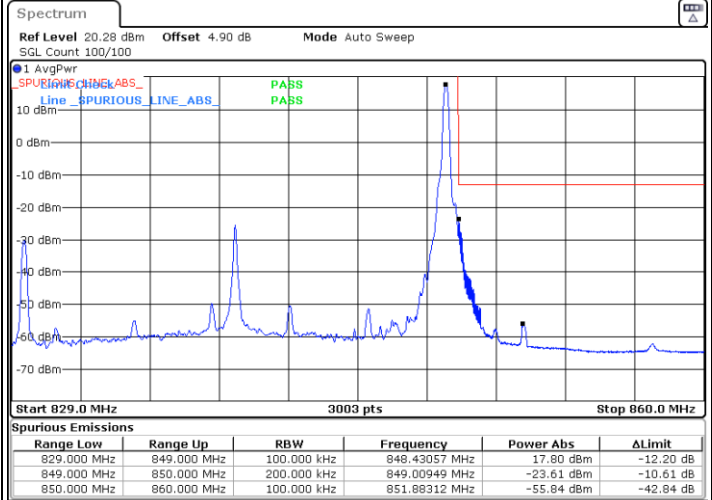
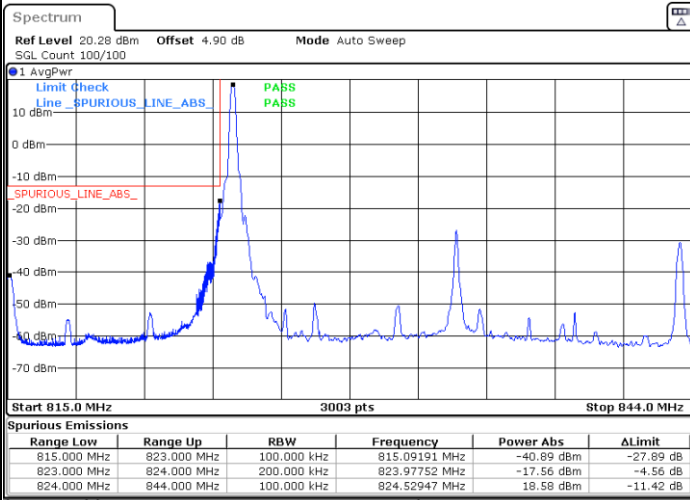

Date: 1.APR.2021 15:48:53

Date: 1.APR.2021 15:58:47

Lowest Band Edge / Full RB

Highest Band Edge / Full RB

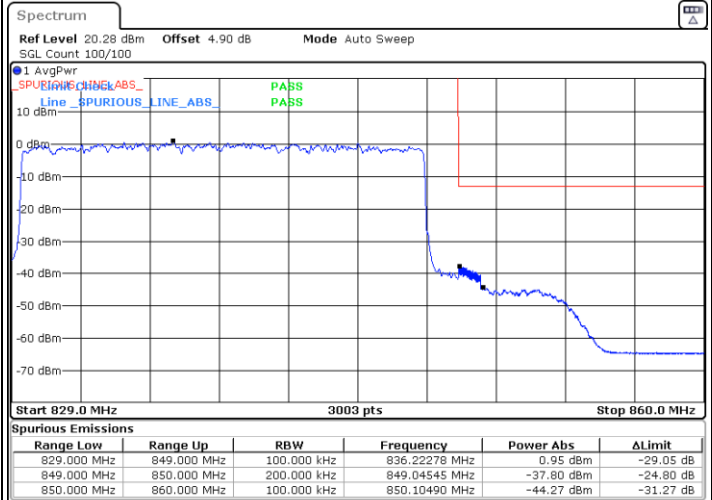
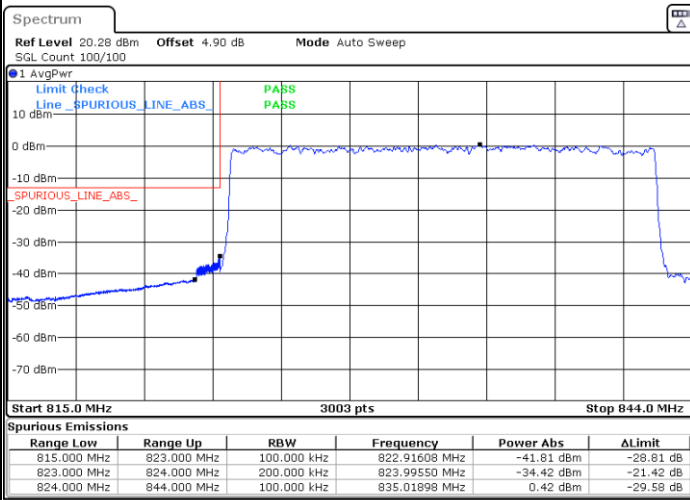

Date: 1.APR.2021 15:52:12

Date: 1.APR.2021 15:55:37



FR1 n5 / 20MHz / DFT-s-OFDM / 256QAM

Lowest Band Edge / 1RB0

Highest Band Edge / 1RBmax

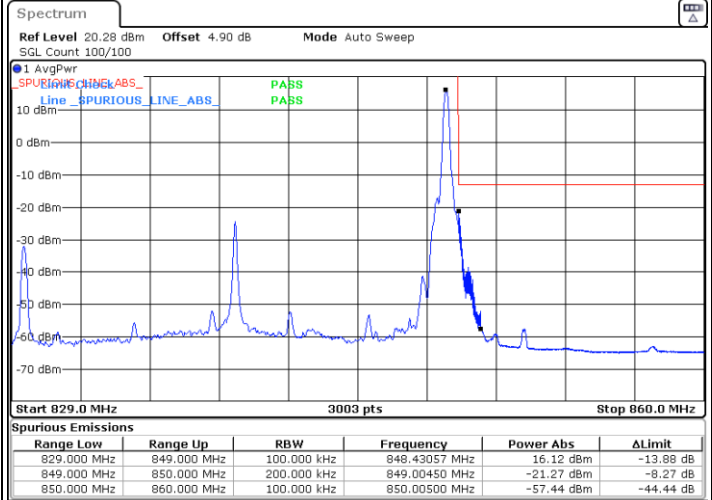
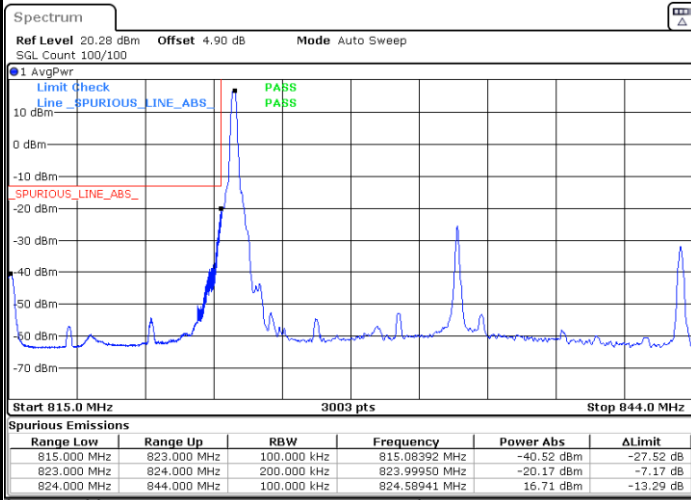

Date: 1.APR.2021 15:49:26

Date: 1.APR.2021 16:00:01

Lowest Band Edge / Full RB

Highest Band Edge / Full RB

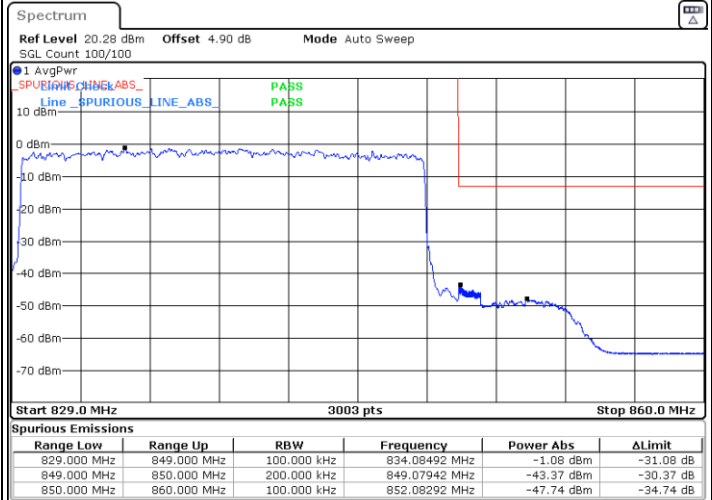
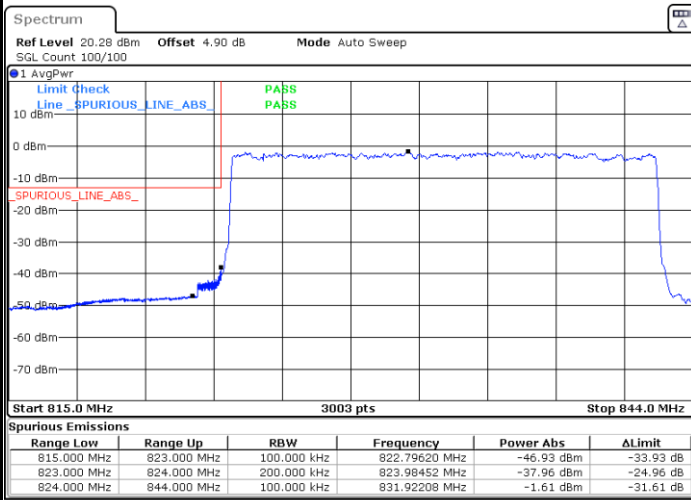

Date: 1.APR.2021 15:52:43

Date: 1.APR.2021 15:56:14



Conducted Spurious Emission



FR1 n5 / 5MHz / DFT-S OFDM / QPSK

Lowest Channel / 1RB1

Middle Channel / 1RB1

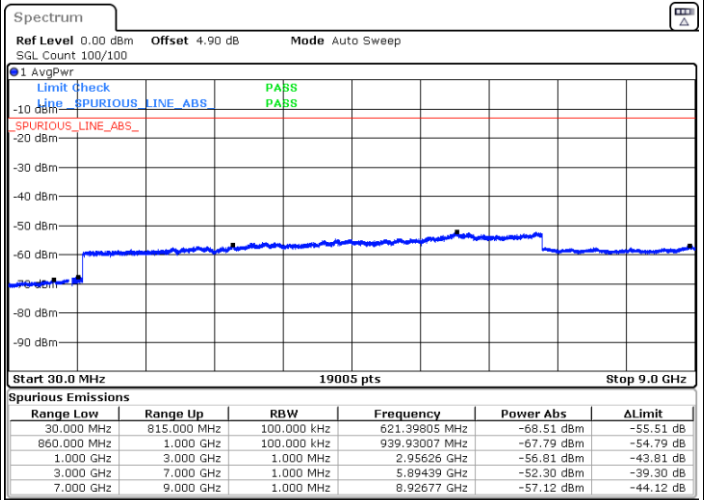
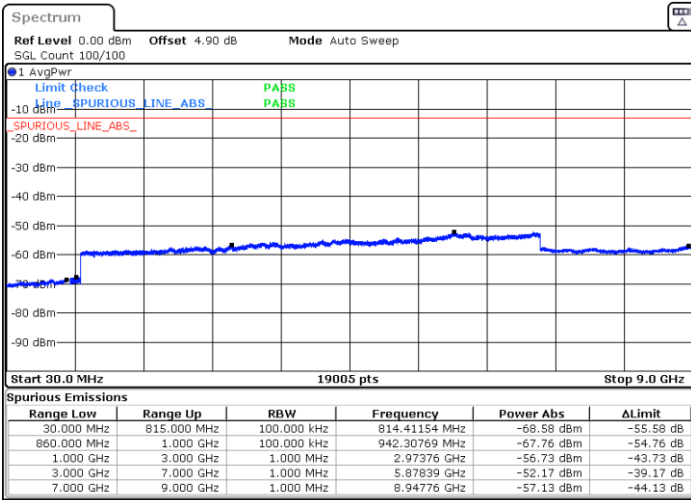

Date: 1.APR.2021 16:24:27

Date: 1.APR.2021 16:25:14

Highest Channel / 1RB1

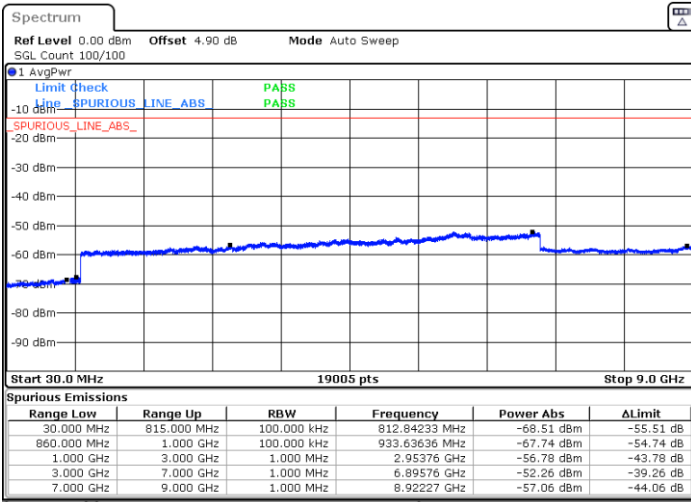

Date: 1.APR.2021 16:27:00