

RF Exposure Report

Report No.: SA180820C22D R1

FCC ID: A5M-A940WC

Test Model: Yoga A940-27ICB

Machine Type: F0E4*****, F0E5*****

(Where postfix x(or*) will be combination of blank, or numbers 0~9, or letters A~Z. It indicates the information for sales, warranty, and marketing geography, with no impact on RF compliance of the product.)

Received Date: Sep. 04, 2018

Test Date: Oct. 19 ~ Oct. 20, 2018

Issued Date: Nov. 28, 2018

Applicant: Lenovo (Beijing) limited

Address: No. 6 chuang Ye Road, Shang Di Information Industry Base , Haidian District, Beijing 10085, CHINA

Issued By: Bureau Veritas Consumer Products Services (H.K.) Ltd., Taoyuan Branch

Lab Address: No. 47-2, 14th Ling, Chia Pau Vil., Lin Kou Dist., New Taipei City, Taiwan, R.O.C.

Test Location: No. 19, Hwa Ya 2nd Rd., Wen Hwa Vil., Kwei Shan Dist., Taoyuan City 33383, TAIWAN (R.O.C.)

**FCC Registration /
Designation Number:** 788550 / TW0003



This report is for your exclusive use. Any copying or replication of this report to or for any other person or entity, or use of our name or trademark, is permitted only with our prior written permission. This report sets forth our findings solely with respect to the test samples identified herein. The results set forth in this report are not indicative or representative of the quality or characteristics of the lot from which a test sample was taken or any similar or identical product specifically and expressly noted. Our report includes all of the tests requested by you and the results thereof based upon the information that you provided to us. You have 60 days from date of issuance of this report to notify us of any material error or omission caused by our negligence, provided, however, that such notice shall be in writing and shall specifically address the issue you wish to raise. A failure to raise such issue within the prescribed time shall constitute your unqualified acceptance of the completeness of this report, the tests conducted and the correctness of the report contents. Unless specific mention, the uncertainty of measurement has been explicitly taken into account to declare the compliance or non-compliance to the specification. The report must not be used by the client to claim product certification, approval, or endorsement by any government agencies.

Table of Contents

Release Control Record	3
1 Certificate of Conformity	4
2 General Information	5
2.1 General Description of EUT	5
2.2 Description of Test Modes.....	5
3 RF Exposure	6
3.1 Description of Support Units	6
3.1.1 Configuration of System under Test	6
3.2 Test Setup	7
3.3 Test Instruments.....	7
3.4 Limits for Maximum Permissible Exposure (MPE).....	8
3.5 Test Point Description	8
4 Calculation Result of Maximum Conducted Power	9
5 Photographs of the Test Configuration	13

Release Control Record

Issue No.	Description	Date Issued
SA180820C22D	Original release	Nov. 07, 2018
SA180820C22D R1	Revised Antenna type	Nov. 28, 2018

1 Certificate of Conformity

Product: All-In-One-Computer

Brand: Lenovo

Model No.: Yoga A940-27ICB

Machine Type: F0E4*****, F0E5*****

(Where postfix x(or*) will be combination of blank, or numbers 0~9, or letters A~Z.
It indicates the information for sales, warranty, and marketing geography, with no
impact on RF compliance of the product.)

Sample Status: Engineering sample

Applicant: Lenovo (Beijing) limited

Test Date: Oct. 19 ~ Oct. 20, 2018

Standards: FCC Part 1 (Section 1.1310)

KDB 680106 D01 RF Exposure Wireless Charging Apps v03

The above equipment has been tested by **Bureau Veritas Consumer Products Services (H.K.) Ltd., Taoyuan Branch**, and found compliance with the requirement of the above standards. The test record, data evaluation & Equipment Under Test (EUT) configurations represented herein are true and accurate accounts of the measurements of the sample's RF characteristics under the conditions specified in this report.

Prepared by : Pettie Chen , **Date:** Nov. 28, 2018
Pettie Chen / Senior Specialist

Approved by : Bruce Chen , **Date:** Nov. 28, 2018
Bruce Chen / Project Engineer

2 General Information

2.1 General Description of EUT

Product	All-In-One-Computer
Brand	Lenovo
Test Model	Yoga A940-27ICB
Machine Type	F0E4*****, F0E5***** (Where postfix x(or*) will be combination of blank, or numbers 0~9, or letters A~Z. It indicates the information for sales, warranty, and marketing geography, with no impact on RF compliance of the product.)
Sample Status	Engineering sample
Power Supply Rating	20Vdc (adapter)
Operating Frequency	110~145kHz
Antenna Type	Loop antenna
Field Strength	81.0dBuV/m
Accessory Device	Adapter
Data Cable Supplied	NA

Note:

1. The EUT uses following adapter.

Brand	Lenovo
Model	A18-230P1A
Input Power	100-240 Vac, 50-60 Hz, 3.5 A
Output Power	20 Vdc, 11.5 A
Power Cable	1.75m non-shielded power cable with two cores

2. The EUT has WPC (Wireless Power Consortium) technology.

3. WPC Vender: Luxshare; WPC Model: LPS-15WP D

2.2 Description of Test Modes

1 channel is provided to this EUT

Channel	Freq. (kHz)
1	127

3 RF Exposure

3.1 Description of Support Units

The EUT has been tested as an independent unit together with other necessary accessories or support units. The following support units or accessories were used to form a representative test configuration during the tests.

ID	Product	Brand	Model No.	Serial No.	FCC ID	Remarks
A.	Keyboard	DELL	SK-8115	CN-OJ4635-71616-53-OCAE	FCC DoC Approved	-
B.	Mouse	DELL	MS111-P	CN-011D3V-71581-1CJ-0936	FCC DoC Approved	-
C.	iPhone X	Apple	A1901	NA	NA	-
D.	Load	NA	NA	NA	NA	-

ID	Descriptions	Qty.	Length (m)	Shielding (Yes/No)	Cores (Qty.)	Remarks
1.	USB cable	1	2	Y	0	-
2.	USB cable	1	1.8	Y	0	-
3.	RJ45 cable	1	1.5	N	0	-

Note: The core(s) is(are) originally attached to the cable(s)

3.1.1 Configuration of System under Test

Charging Mode (Test Mode A)

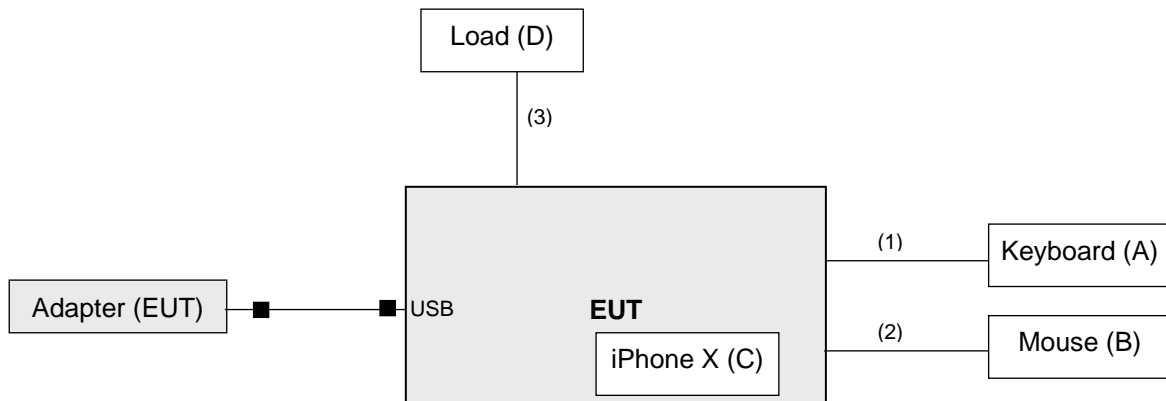

Standby Mode (Test Mode B)

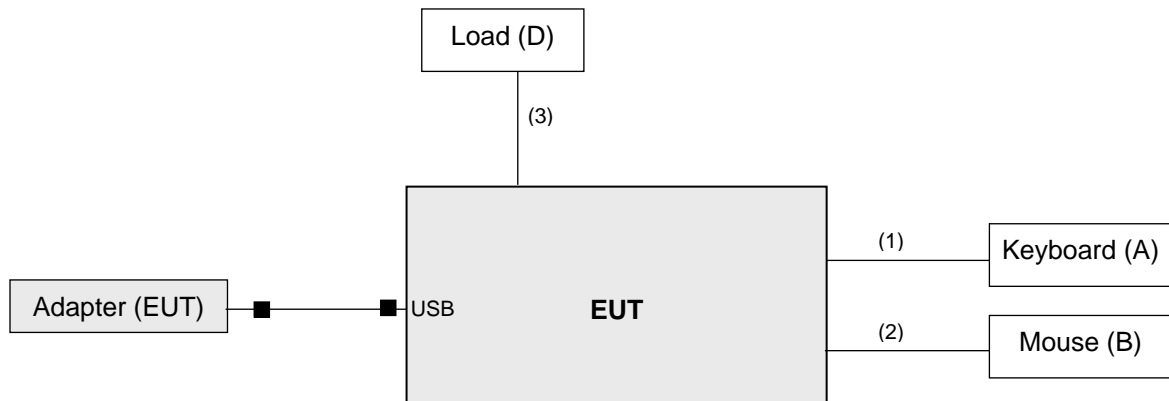

3.2 Test Setup

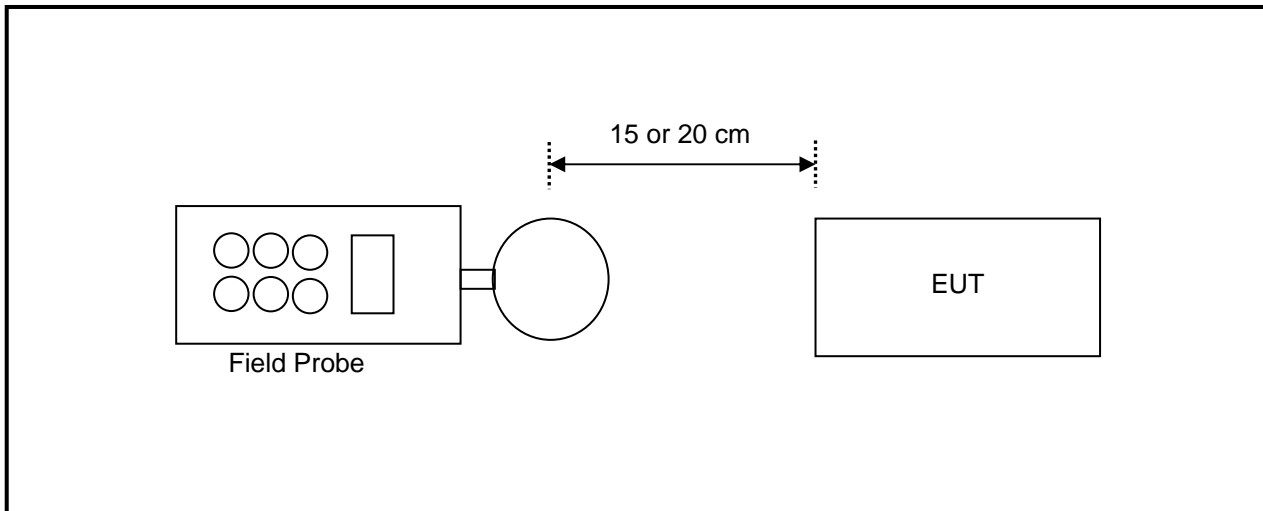

Note: Measurements should be made from all sides and the top of the primary/client pair, with the 15 or 20 cm measured from the center of the probe(s) to the edge of the device.

3.3 Test Instruments

Description	Brand	Model No.	Frequency Range	Calibrated Date	Calibrated Until
Broadband Field Meter	NARDA	NBM-550	-	Mar. 28, 2018	Mar. 27, 2020
Magnetic Field Meter	NARDA	ELT-400	1 – 400kHz	Apr. 12, 2018	Apr. 11, 2020
Broadband Field Meter	NARDA	NBM-550	-	Mar. 28, 2018	Mar. 27, 2020
Magnetic Field Probe	NARDA	2300/90.10	1Hz – 400kHz	Apr. 12, 2018	Apr. 11, 2020
E-Field Probe	NARDA	EF 0391	100kHz – 3GHz	Mar. 28, 2018	Mar. 27, 2020

- Note: 1. The calibration interval of the above test instruments is 12/24 months and the calibrations are traceable to NML/ROC and NIST/USA.
 2. The test was performed in HwaYa RF Chamber

3.4 Limits for Maximum Permissible Exposure (MPE)

§ 1.1310 The criteria listed in table 1 shall be used to evaluate the environmental impact of human exposure to radiofrequency(RF) radiation.

TABLE 1—LIMITS FOR MAXIMUM PERMISSIBLE EXPOSURE (MPE)

Frequency range (MHz)	Electric field strength (V/m)	Magnetic field strength (A/m)	Power density (mW/cm ²)	Averaging time (minutes)
(A) Limits for Occupational/Controlled Exposures				
0.3–3.0	614	1.63	*(100)	6
3.0–30	1842/f	4.89/f	*(900/f ²)	6
30–300	61.4	0.163	1.0	6
300–1500	f/300	6
1500–100,000	5	6
(B) Limits for General Population/Uncontrolled Exposure				
0.3–1.34	614	1.63	*(100)	30
1.34–30	824/f	2.19/f	*(180/f ²)	30
30–300	27.5	0.073	0.2	30
300–1500	f/1500	30
1500–100,000	1.0	30

f = frequency in MHz

* = Plane-wave equivalent power density

NOTE 1 TO TABLE 1: Occupational/controlled limits apply in situations in which persons are exposed as a consequence of their employment provided those persons are fully aware of the potential for exposure and can exercise control over their exposure. Limits for occupational/controlled exposure also apply in situations when an individual is transient through a location where occupational/controlled limits apply provided he or she is made aware of the potential for exposure.

NOTE 2 TO TABLE 1: General population/uncontrolled exposures apply in situations in which the general public may be exposed, or in which persons that are exposed as a consequence of their employment may not be fully aware of the potential for exposure or can not exercise control over their exposure.

680106 D01 RF Exposure Wireless Charging Apps v03

The aggregate H-field strengths at 15 cm surrounding the device and 20 cm above the top surface from all simultaneous transmitting coils are demonstrated to be less than 50% of the MPE limit.

3.5 Test Point Description

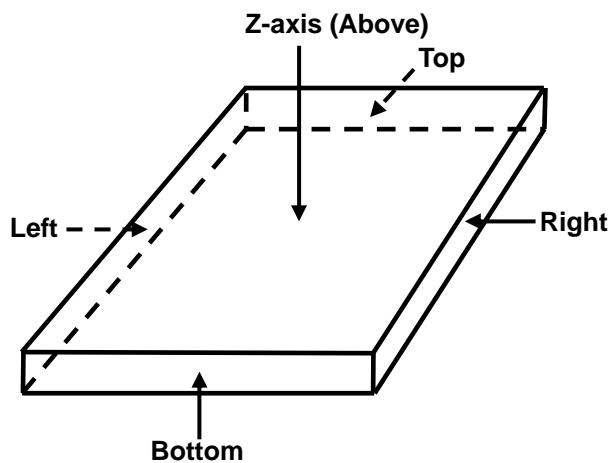

4 Calculation Result of Maximum Conducted Power

Charging Mode with iPhone, battery 10% Charge

H-Field Measurement (15cm)					H-Field Measurement (20cm)
EUT Side	Left	Right	Top	Bottom	Z-axis (Above)
Max E-field (V/m)	0.51	0.58	0.32	0.36	0.38
Limit (V/m)	614	614	614	614	614
Margin (V/m)	-613.49	-613.42	-613.68	-613.64	-613.62
50 % Limit (V/m)	307	307	307	307	307
50 % Margin (V/m)	-306.49	-306.42	-306.68	-306.64	-306.62

H-Field Measurement (15cm)					H-Field Measurement (20cm)
EUT Side	Left	Right	Top	Bottom	Z-axis (Above)
Max H-field (uT)	0.051	0.048	0.043	0.068	0.046
Max H-field (A/m)	0.0408	0.0384	0.0344	0.0544	0.0368
Limit (A/m)	1.63	1.63	1.63	1.63	1.63
Margin (A/m)	-1.5892	-1.5916	-1.5956	-1.5756	-1.5932
50 % Limit (A/m)	0.815	0.815	0.815	0.815	0.815
50 % Margin (A/m)	-0.7742	-0.7766	-0.7806	-0.7606	-0.7782

Measurement was made from all sides and the top of the primary/client pair, with the 15 cm measured from the center of the probe(s) to the edge of the device, with the 20 cm measured from the center of the probe(s) to the edge of the device. Z-axis (Above)

The highest emission level was recorded.

Charging Mode with iPhone, battery 50% Charge

H-Field Measurement (15cm)					H-Field Measurement (20cm)
EUT Side	Left	Right	Top	Bottom	Z-axis (Above)
Max E-field (V/m)	0.53	0.61	0.33	0.39	0.42
Limit (V/m)	614	614	614	614	614
Margin (V/m)	-613.47	-613.39	-613.67	-613.61	-613.58
50 % Limit (V/m)	307	307	307	307	307
50 % Margin (V/m)	-306.47	-306.39	-306.67	-306.61	-306.58

H-Field Measurement (15cm)					H-Field Measurement (20cm)
EUT Side	Left	Right	Top	Bottom	Z-axis (Above)
Max H-field (uT)	0.053	0.051	0.048	0.069	0.049
Max H-field (A/m)	0.0424	0.0408	0.0384	0.0552	0.0392
Limit (A/m)	1.63	1.63	1.63	1.63	1.63
Margin (A/m)	-1.5876	-1.5892	-1.5916	-1.5748	-1.5908
50 % Limit (A/m)	0.815	0.815	0.815	0.815	0.815
50 % Margin (A/m)	-0.7726	-0.7742	-0.7766	-0.7598	-0.7758

Measurement was made from all sides and the top of the primary/client pair, with the 15 cm measured from the center of the probe(s) to the edge of the device, with the 20 cm measured from the center of the probe(s) to the edge of the device. Z-axis (Above)
 The highest emission level was recorded.

Charging Mode with iPhone, battery 90% Charge

H-Field Measurement (15cm)					H-Field Measurement (20cm)
EUT Side	Left	Right	Top	Bottom	Z-axis (Above)
Max E-field (V/m)	0.54	0.65	0.38	0.43	0.43
Limit (V/m)	614	614	614	614	614
Margin (V/m)	-613.46	-613.35	-613.62	-613.57	-613.57
50 % Limit (V/m)	307	307	307	307	307
50 % Margin (V/m)	-306.46	-306.35	-306.62	-306.57	-306.57

H-Field Measurement (15cm)					H-Field Measurement (20cm)
EUT Side	Left	Right	Top	Bottom	Z-axis (Above)
Max H-field (uT)	0.055	0.052	0.049	0.072	0.053
Max H-field (A/m)	0.044	0.0416	0.0392	0.0576	0.0424
Limit (A/m)	1.63	1.63	1.63	1.63	1.63
Margin (A/m)	-1.586	-1.5884	-1.5908	-1.5724	-1.5876
50 % Limit (A/m)	0.815	0.815	0.815	0.815	0.815
50 % Margin (A/m)	-0.771	-0.7734	-0.7758	-0.7574	-0.7726

Measurement was made from all sides and the top of the primary/client pair, with the 15 cm measured from the center of the probe(s) to the edge of the device, with the 20 cm measured from the center of the probe(s) to the edge of the device. Z-axis (Above)

The highest emission level was recorded.

Standby Mode

H-Field Measurement (15cm)					H-Field Measurement (20cm)
EUT Side	Left	Right	Top	Bottom	Z-axis (Above)
Max E-field (V/m)	0.31	0.32	0.25	0.21	0.25
Limit (V/m)	614	614	614	614	614
Margin (V/m)	-613.69	-613.68	-613.75	-613.79	-613.75
50 % Limit (V/m)	307	307	307	307	307
50 % Margin (V/m)	-306.69	-306.68	-306.75	-306.79	-306.75

H-Field Measurement (15cm)					H-Field Measurement (20cm)
EUT Side	Left	Right	Top	Bottom	Z-axis (Above)
Max H-field (uT)	0.038	0.034	0.029	0.048	0.025
Max H-field (A/m)	0.0304	0.0272	0.0232	0.0384	0.02
Limit (A/m)	1.63	1.63	1.63	1.63	1.63
Margin (A/m)	-1.5996	-1.6028	-1.6068	-1.5916	-1.61
50 % Limit (A/m)	0.815	0.815	0.815	0.815	0.815
50 % Margin (A/m)	-0.7846	-0.7878	-0.7918	-0.7766	-0.795

Measurement was made from all sides and the top of the primary/client pair, with the 15 cm measured from the center of the probe(s) to the edge of the device, with the 20 cm measured from the center of the probe(s) to the edge of the device. Z-axis (Above)

The highest emission level was recorded.

5 Photographs of the Test Configuration

Please refer to the attached file (Test Setup Photo).

--- END ---