

TEST REPORT

of

FCC SAR

New Application; Class I PC; Class II PC

Product Description: Body Camera

Brand Name: Transcend

Model Name: DrivePro Body 30

Model Difference: N/A

FCC ID: A4Z-B001E

Standard: IEEE 1528: 2013

FCC KDB 447498: 2015

Applicant: Transcend Information Inc.

Address: No.70, Xing Zhong Rd., NeiHu Dist., Taipei,
Taiwan

Test Performed by:
International Standards Laboratory

<Lung-Tan LAB>

*Site Registration No.: TAF: 0997

*Address:

No. 120, Lane 180, Hsin Ho Rd.,

Lung-Tan Dist., Tao Yuan City 325, Taiwan

*Tel : 886-3-407-1718; Fax: 886-3-407-1738

Report No.: **ISL-17LR138FSAR**

Issue Date : **2017/07/06**



Test results given in this report apply only to the specific sample(s) tested and are traceable to national or international standard through calibration of the equipment and evaluating measurement uncertainty herein.

This report MUST not be used to claim product endorsement by TAF or any agency of the Government. This test report shall not be reproduced except in full, without the written approval of International Standards Laboratory.

VERIFICATION OF COMPLIANCE

Applicant: Transcend Information Inc.
Product Description: Body Camera
Brand Name: Transcend
Host Model No.: DrivePro Body 30
Model Difference: N/A
FCC ID: A4Z-B001E
Date of Receipt: 2017/06/26
Date of Test: 2017/07/05
Standard: IEEE 1528: 2013
FCC KDB 447498: 2015

We hereby certify that:

All the tests in this report have been performed and recorded in accordance with the standards described above and performed by an independent electromagnetic compatibility consultant, International Standards Laboratory.

The test results contained in this report accurately represent the measurements of the characteristics and the energy generated by sample equipment under test at the time of the test. The sample equipment tested as described in this report is in compliance with the limits of above standards.

Test By: Dino Chen **Date:** 2017/07/06
Dino Chen / Engineer

Prepared By: Dino Chen **Date:** 2017/07/06
Dino Chen / Engineer

Approved By: Vincent Su **Date:** 2017/07/06
Vincent Su / Technical Manager

Version

Version No.	Date	Description
00	2017/07/06	Initial creation of document

Table of Contents

1	STATEMENT OF COMPLIANCE	5
2	GENERAL INFORMATION	6
2.1	DESCRIPTION OF DEVICE UNDER TEST (DUT).....	6
2.2	DUT PHOTOS	8
2.3	APPLIED STANDARDS	8
2.4	TEST FACILITY.....	8
2.5	DEVICE CATEGORY AND SAR LIMITS.....	8
2.6	TEST ENVIRONMENT.....	9
2.7	TEST CONFIGURATION.....	9
3	SPECIFIC ABSORPTION RATE (SAR).....	10
3.1	INTRODUCTION	10
3.2	SAR DEFINITION	10
4	SAR MEASUREMENT SYSTEM	11
4.1	ALSAS-10U SYSTEM DESCRIPTION.....	11
4.2	E-FIELD PROBE ALS-E-020S	12
4.3	DAQ-PAQ (ANALOG TO DIGITAL ELECTRONICS) ALS-DAQ-PAQ-3 BOUNDARY DETECTION UNIT ALS-PMDPS-3.....	14
4.4	AXIS ARTICULATED ROBOT ALS-F3	16
4.5	ALSAS UNIVERSAL WORKSTATION ALS-UWS.....	16
4.6	SAM PHANTOMS ALS-P-SAM-L / ALS-P-SAM-R.....	17
4.7	UNIVERSAL DEVICE POSITIONER	19
4.8	TEST EQUIPMENT LIST.....	20
5	TISSUE SIMULATING LIQUIDS.....	21
6	SAR MEASUREMENT EVALUATION.....	23
7	DUT TESTING POSITION	25
8	SAR MEASUREMENT PROCEDURES	28
9	SAR TEST RESULTS	30
9.1	CONDUCTED POWER TABLE:.....	30
9.2	TEST RECORDS FOR BODY SAR TEST	32
10	EXPOSURE ASSESSMENT MEASUREMENT UNCERTAINTY.....	38
APPENDIX A	TEST SETUP PHOTOS.....	40
APPENDIX B	DUT PHOTOS	45
APPENDIX C	SYSTEM VALIDATION	45
APPENDIX D	SAR WORST MEASUREMENT DATA	45
APPENDIX E	PROBE CALIBRATION CERTIFICATE	45
APPENDIX F	DIPOLE CALIBRATION CERTIFICATE.....	45
APPENDIX G	SYSTEM CHECK (ANNUAL).....	45

1 Statement of Compliance

The maximum results of Specific Absorption Rate (SAR) were found during testing for EUT, which are as follows (with expanded uncertainty 21.4 % for 300 MHz to 3 GHz).

FCC SAR Value

Type	Position	SAR 1g(W/kg)
802.11b	Body, 0cm	0.810
802.11g	Body, 0cm	0.896
802.11n 20	Body, 0cm	0.724
BT BDR	Body, 0cm	0.002
BT BLE	Body, 0cm	0.002

The device is in compliance with Specific Absorption Rate (SAR) for general population /uncontrolled exposure limits (1.6 W/kg) specified in FCC 47 CFR part 2 (2.1093) had been tested in accordance with the measurement methods and procedures specified in IEEE1528: 2013 and FCC OET Bulletin 65 Supplement C (Edition 01-01).

2 General Information

2.1 Description of Device Under Test (DUT)

General:

Product Name	Body Camera	
Brand Name	Transcend	
Model Name	DrivePro Body 30	
Model Difference	N/A	
Power Supply	5Vdc from AC/DC adapter or 3.6Vdc from Battery	
	Adapter:	Model: WB-10G05R
	Battery:	Model: DPB30

Wifi: 1Tx, 1Rx

Wi-Fi	Frequency Range (MHz)	Channels	Peak / Average Power	Modulation Technology
802.11b	2412 – 2462(DTS)	11	13.87dBm (PK) /11.21 dBm (AV)	DSSS
802.11n	2412 – 2462(DTS)	11	22.43dBm (PK) /12.92 dBm (AV)	OFDM
	HT20 2412 – 2462(DTS)	11	21.98dBm (PK) /12.31 dBm (AV)	
Modulation type	CCK, DQPSK, DBPSK for DSSS 64QAM, 16QAM, QPSK, BPSK for OFDM			
Antenna Designation	Type: Chip Antenna, 3.32 dBi max			
Tune up power (Average)	802.11b:11dBm +/- 1.5 dBm 802.11b:12dBm +/- 1.5 dBm 802.11b:11dBm +/- 1.5 dBm			

The EUT is compliance with IEEE 802.11 b/g/n Standard.

BT: 1Tx, 1Rx

Bluetooth Version	V2.1 + EDR (GFSK + $\pi/4$ DQPSK + 8DPSK)	BLE (GFSK)
Frequency Range:	2402 – 2480MHz	2402 – 2480MHz
Channel number:	79 channels	40 channels
Modulation type:	Frequency Hopping Spread Spectrum (FHSS)	Wide band Modulation
Transmit Power: (Peak)	0.65 dBm	0.83 dBm
Dwell Time:	$\leq 0.4s$	N/A
Antenna Designation:	Type: Chip Antenna, 3.32 dBi max	
Tune up Power(Average)	12 dBm +/- 1 dBm	

The EUT is compliance with Bluetooth V2.1 + EDR and BT4.1.

Remark: The above DUT's information was declared by manufacturer. Please refer to the specifications or user's manual for more detailed description.

2.2 DUT Photos

Please refer to Appendix B.

2.3 Applied Standards

The Specific Absorption Rate (SAR) testing specification, method and procedure for this Notebook Computer is in accordance with the following standards:

IEEE 1528: 2013

FCC KDB 447498 D01 General RF Exposure Guidance v06

FCC KDB 865664 D01 SAR Measurement 100 MHz to 6 GHz v01r04

FCC KDB 248227 D01 802.11 Wi-Fi SAR v02r02

2.4 Test Facility

The measurement facilities used to collect the SAR data are located on the address of International Standards Laboratory <Lung-Tan LAB> No. 120, Lane 180, Hsin Ho Rd., Lung-Tan Dist., Tao Yuan City 325, Taiwan. FCC Registration Number is: TW1036, Canada Registration Number: 4067B.

2.5 Device Category and SAR Limits

This device belongs to **portable** device category because its radiating structure is allowed to be used within 20 centimeters of the body of the user. Limit for **General Population/Uncontrolled** exposure should be applied for this device, it is **1.6 W/kg** as averaged over any 1 gram of tissue.

Limits for General Population/Uncontrolled Exposure (W/kg)

Type Exposure	Uncontrolled Environment Limit
Spatial Peak SAR (1g cube tissue for brain or body)	1.60 W/kg
Spatial Average SAR (whole body)	0.08 W/kg
Spatial Peak SAR (10g for hands, feet, ankles and wrist)	4.00 W/kg

2.6 Test Environment

Item	Required	Actual
Temperature (°C)	18-25°C	20 to 24 °C
Humidity (%RH)	30-70 %	< 60 %

2.7 Test Configuration

The device was controlled by using a test software to transmit TX power level at max continuously. Modulation type and Channel number are selected by software also.

3 Specific Absorption Rate (SAR)

3.1 Introduction

SAR is related to the rate at which energy is absorbed per unit mass in an object exposed to a radio field. The SAR distribution in a biological body is complicated and is usually carried out by experimental techniques or numerical modeling. The standard recommends limits for two tiers of groups, occupational/controlled and general population/uncontrolled, based on a person's awareness and ability to exercise control over his or her exposure. In general, occupational/controlled exposure limits are higher than the limits for general population/uncontrolled.

3.2 SAR Definition

The SAR definition is the time derivative (rate) of the incremental energy (dW) absorbed by (dissipated in) an incremental mass (dm) contained in a volume element (dv) of a given density (ρ). The equation description is as below:

$$SAR = \frac{d}{dt} \left(\frac{dW}{dm} \right) = \frac{d}{dt} \left(\frac{dW}{\rho dV} \right)$$

SAR is expressed in units of Watts per kilogram (W/kg)

SAR measurement can be either related to the temperature elevation in tissue by

$$SAR = C \left(\frac{\delta T}{\delta t} \right)$$

Where: C is the specific heat capacity, δT is the temperature rise and δt is the exposure duration, or related to the electrical field in the tissue by

$$SAR = \frac{\sigma |E|^2}{\rho}$$

Where: σ is the conductivity of the tissue, ρ is the mass density of the tissue and E is the RMS electrical field strength.

However for evaluating SAR of low power transmitter, electrical field measurement is typically applied.

4 SAR Measurement System

4.1 ALSAS-10U System Description

APREL Laboratories ALSAS-10U is fully optimized for the dosimetric evaluation of a broad range of wireless transceivers and antennas. Developed in line with the latest methodologies it is fully compliant with the technical and scientific requirements of IEEE 1528: 2013, IEC 62209 Part 1 & 2 (draft), CENELEC, ARIB, ACA, and the Federal Communications Commission. The system comprises of a six axes articulated robot which utilizes a dedicated controller.

ALSAS-10U uses the latest methodologies and FDTD modeling to provide a platform which is repeatable with minimum uncertainty.

Applications

ALSAS-10U is designed to cover the frequency range from 30MHz to 6GHz as per the IEC 62209 Part II (draft) standard. There is no limiting factor to the operating RF carrier frequency range for the ALSAS-10U system other than the phantoms chosen for testing. The ALSAS-10U has been designed to be modular and phantoms are integrated onto the Universal Workstation™ so as to allow for complete flexibility of the measurement process. This unique design allows for a fully flexible system which can be built around the exact needs of the user.



Area Scans

Area scans are defined prior to the measurement process being executed with a user defined variable spacing between each measurement point (integral) allowing low uncertainty measurements to be conducted. Scans defined for FCC applications utilize a 10mm² step integral, with 1mm interpolation used to locate the peak SAR area used for zoom scan assessments.

Where the system identifies multiple SAR peaks (which are within 25% of peak value) the system will provide the user with the option of assessing each peak location individually for zoom scan averaging.

Zoom Scan (Cube Scan Averaging)

The averaging zoom scan volume utilized in the ALSAS-10U software is in the shape of a cube and the side dimension of a 1 g or 10 g mass is dependent on the density of the liquid representing the simulated tissue. A density of 1000 kg/m³ is used to represent the head and body tissue density and not the phantom liquid density, in order to be consistent with the definition of the liquid dielectric properties, i.e. the side length of the 1 g cube is 10mm, with the side length of the 10 g cube 21,5mm.

When the cube intersects with the surface of the phantom, it is oriented so that 3 vertices touch the surface of the shell or the center of a face is tangent to the surface. The face of the cube closest to the surface is modified in order to conform to the tangent surface.

The zoom scan integer steps can be user defined so as to reduce uncertainty, but normal practice for typical test applications (including FCC) utilize a physical step of 5x5x8 (8mmx8mmx5mm) providing a volume of 32mm in the X & Y axis, and 35mm in the Z axis.

ALSAS-10U Interpolation and Extrapolation Uncertainty

The overall uncertainty for the methodology and algorithms the used during the SAR calculation was evaluated using the data from IEEE 1528: 2013 based on the example f3 algorithm:

$$f_3(x, y, z) = A \frac{a^2}{\frac{a^2}{4} + x'^2 + y'^2} \cdot \left(e^{-\frac{2z}{a}} + \frac{a^2}{2(a + 2z)^2} \right)$$

Refer to raw data for measurement uncertainty

4.2 E-Field Probe ALS-E-020S

The isotropic E-Field probe has been fully calibrated and assessed for isotropicity, and boundary effect within a controlled environment. Depending on the frequency for which the probe is calibrated the method utilized for calibration will change. A number of methods is used for calibrating probes, and these are outlined in the table below:

The E-Field probe utilizes a triangular sensor arrangement as detailed in the diagram below:

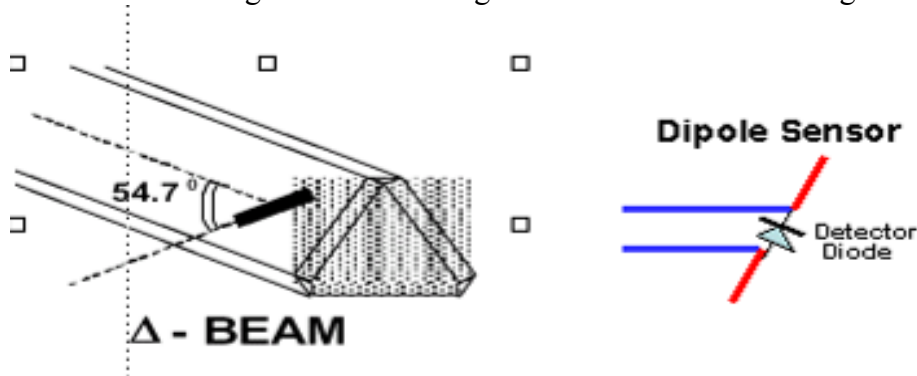

SAR is assessed with a calibrated probe which moves at a default height of 5mm from the center of the diode, which is mounted to the sensor, to the phantom surface (in the Z Axis). The 5mm offset height has been selected so as to minimize any resultant boundary effect due to the probe being in close proximity to the phantom surface.

The following algorithm is an example of the function used by the system for linearization of the output from the probe when measuring complex modulation schemes.

$$V_i = U_i + U_i^2 \cdot \frac{cf}{dcp_i}$$

4.2.1 E-Field Probe Specification

Model: ALS-E-020S

Compliant Standards	IEEE 1528: 2013
Frequency Range	30 MHz ~ 6 GHz
Sensitivity	Better than 0.8 μ V/(V/m) ²
Dynamic Range SAR	0.001 W/kg to 100 W/kg
Isotropic Response Axial	Typically \pm 0.1dB
Hemispherical isotropy	\pm 0.3 dB or better
Linearity	\pm 0.2 dB or better
Probe Tip Radius	User selectable all <5 mm
Sensor Offset	1.56 (\pm 0.02 mm)
Probe Length	290 mm
Video Bandwidth	@ 500 Hz: 1 dB @ 1K Hz: 3 dB
Boundary Effect	Less than 2% for distances greater than 2.4 mm
Material	Ertalyte™
Connector	6 Pin Bayonet

E-Field Probe Calibration

Each probe needs to be calibrated according to a dosimetric assessment procedure with accuracy better than \pm 10%. The spherical isotropy shall be evaluated and within \pm 0.25 dB. The sensitivity parameters (NormX, NormY, and NormZ), the diode compression parameter (DCP) and the conversion factor (ConvF) of the probe are tested. The calibration data can be referred to appendix C of this report.

Boundary Detection Unit and Probe Mounting Device

ALSAS-10U incorporates a boundary detection unit with a sensitivity of 0.05mm for detecting all types of surfaces. The robust design allows for detection during probe tilt (probe normalize) exercises, and utilizes a second stage emergency stop. The signal electronics are fed directly into the robot controller for high accuracy surface detection in lateral and axial detection modes (X, Y, & Z).

The probe is mounted directly onto the Boundary Detection unit for accurate tooling and displacement calculations controlled by the robot kinematics. The probe is connect to an isolated probe interconnect where the output stage of the probe is fed directly into the amplifier stage of the Daq-Paq.

4.3 DAQ-PAQ (Analog to Digital Electronics) ALS-DAQ-PAQ-3 Boundary Detection Unit ALS-PMDPS-3

ALSAS-10U incorporates a fully calibrated Daq-Paq (analog to digital conversion system) which has a 4 channel input stage, sent via a 2 stage auto-set amplifier module. The input signal is amplified accordingly so as to offer dynamic range from 4 μ V to 330 mV. Integration of the fields measured is carried out at board level utilizing a Co-Processor which then sends the measured fields down into the main computational module in digitized form via an RS232 communications port. Probe linearity and duty cycle compensation is carried out within the main Daq-Paq module.

PMDPS is used to hold a probe and to detect complex boundary locations (curved and flat surfaces) during a SAR or HAC assessment process. It utilizes relative movements of internal components to trigger integrated micro-sensor mechanisms in order to detect boundary(s) and consequently position the probe at the specified distance relative to a boundary in order to achieve accurate and repeatable measurements.

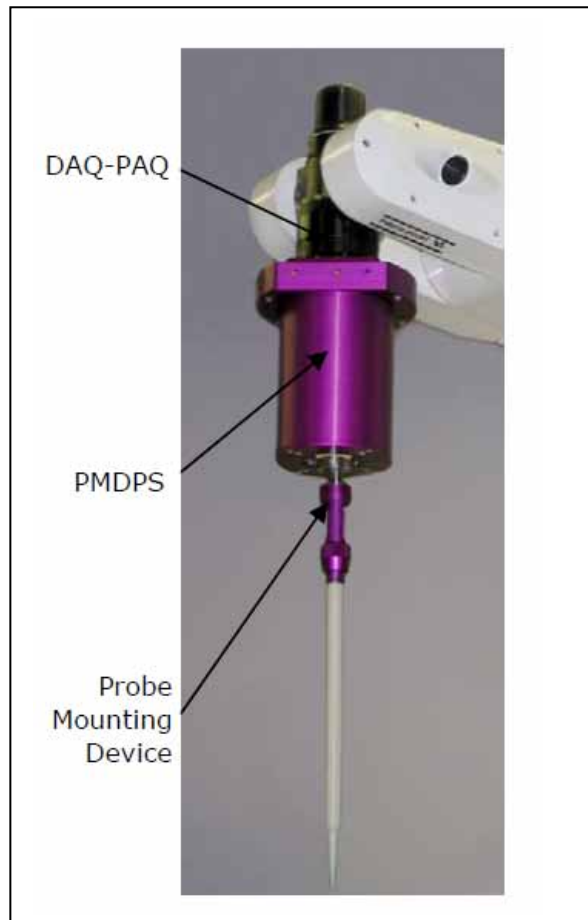

a

Amplifier Range	4 μ V to 330 mV
ADC	16 Bit optically isolated
Built-in E-Stop Feature	Emergency Stop feature to prevent damage of equipment and for user safety purposes
Field Integration	Local Co-Processor utilizing proprietary integration algorithms
SAR Dynamic Range	0.001 W/kg -100 W/kg.
Ambient Noise	Below 0.001 W/kg measured with probe in tissue
LED Indication	Boundary detection and DAQ-PAQ State
Number of Input Channels	4 in total 3 dedicated and 1 spare for future upgrades (when and if needed)
Communication	Optically isolated packet data via RS232
Robot Arm Integration	DAQ-PAQ and Boundary Detection Unit are mounted directly onto joint 6 of the F3 arm utilizing joint 6 tool (ISO Standard M8 Mounting Plate) to allow easy integration and removal (no angular interface)
Supply	DC supply powered by an isolated external supply unit (no battery required)
LED Indicators	Probe status (amplifier on) and boundary detection

PMDPS Specification details

Accuracy of Positioning	Better than 10 μ m at 6GHz
SAR Uncertainty	Better than 0.01 W/kg SAR at 6Gz
Detection Mechanism	2 x 360° Stage Axial and Lateral Detection at 6GHz
Emergency Stop	4 Stage 360° Axial and Lateral Detection at 6GHz
Probe Mounting	6 Pin Bayonet for Fast Probe Change
Calibration	Every PMDPS is Calibrated to 0.01 W/kg SAR at 6GHz
Reliability Expectations	Better Than 10,000,000 Cycles

4.4 Axis Articulated Robot ALS-F3



ALSAS-10U utilizes a six axis articulated robot, which is controlled using a Pentium based real-time movement controller. The movement kinematics engine utilizes proprietary (Thermo CRS) interpolation and extrapolation algorithms, which allow full freedom of movement for each of the six joints within the working envelope. Utilization of joint 6 allows for full probe rotation with a tolerance better than 0.05mm around the central axis.

Robot/Controller Manufacturer	Thermo CRS
Number of Axis	Six independently controlled axis
Positioning Resolution	0.05mm
Controller Type	Single phase Pentium based C500C
Robot Reach	710mm
Repeatability	0.05mm or better
Communication	RS232 and LAN compatible

4.5 ALSAS Universal Workstation ALS-UWS

ALSAS Universal workstation allows for repeatability and fast adaptability. It allows users to do calibration, testing and measurements using different types of phantoms with one set up, which significantly speeds up the measurement process.

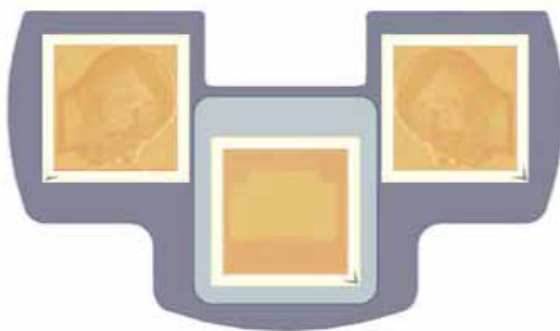

Workstation.
Top view (rendering)

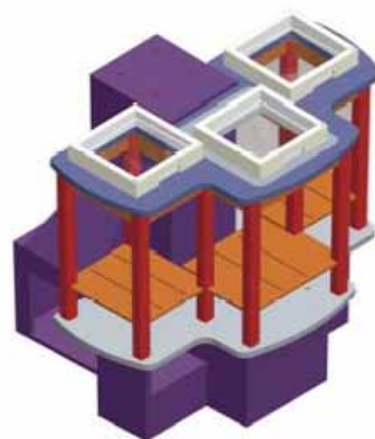

Workstation
without robot (rendering)

4.6 SAM Phantoms ALS-P-SAM-L / ALS-P-SAM-R

The ALSAS-10U allows the integration of multiple phantom types. SAM Phantoms fully compliant with IEEE 1528: 2013, Universal Phantom, and Universal Flat.

APREL SAM Phantoms

The SAM phantoms developed using the IEEE SAM CAD file. They are fully compliant with the requirements for both IEEE 1528: 2013 and FCC Supplement C. Both the left and right SAM phantoms are interchangeable, transparent and include the IEEE 1528: 2013 grid with visible NF and MB lines.

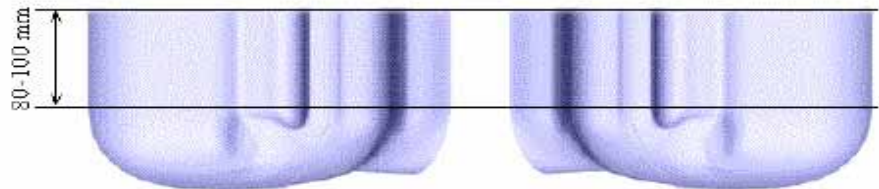

Compliant Standards	IEEE-1528: 2013
SAM	In accordance with the IEEE 1528: 2013 standard
Material	Composite urethane which allows for the device to be viewed through the phantom, resistant to DGBE
Phantom Shell Shape Tolerance	Fully calibrated to be better than ± 0.2 mm
Frame Material	Corian®
Tissue Simulation Volume	7 liter with 15.0 ± 0.5 cm tissue
Thickness	$2 \text{ mm} \pm 0.2 \text{ mm}$ $6 \text{ mm} \pm 0.2 \text{ mm}$ at NF/MB intersection
Loss Tangent	<0.05
Relative Permittivity	<5
Resistant to Solvents	Resistant to all solvents used for tissue manufacturing detailed in IEEE 1528: 2013
Load Deflection	<1mm with sugar water compositions
Manufacturing Process	Injection Molded
Phantom Weight	Less than 10kg when filled with 15cm of simulation tissue

Universal Phantom ALS-P-UP-1

The Universal Phantom is used on the ALSAS-10U as a system validation phantom. The Universal Phantom has been fully validated both experimentally from 800MHz to 6GHz and numerically using XFDTD numerical software. The shell thickness is 2mm overall, with a 4mm spacer located at the NF/MB intersection providing an overall thickness of 6mm in line with the requirements of IEEE-1528: 2013.



The design allows for fast and accurate measurements, of handsets, by allowing the conservative SAR to be evaluated at on frequency for both left and right head experiments in one measurement.

Compliant Standards	IEEE-1528: 2013
Manufacturing Process	Injection molded
Material	Vivac
Phantom Shell Shape Tolerance	Less than ± 0.2 mm
Frame Material	Corian®
Tissue Simulation Volume	8 liter with 15.0 ± 0.5 cm tissue
Thickness	2mm ± 0.2 mm 6mm at NF/MB intersection
Loss Tangent	<0.05
Relative Permittivity	<5
Resistant to Solvents	Resistant to all solvents detailed in IEEE 1528: 2013
Load Deflection	<1mm with heaviest tissue (sugar water compositions)
Dimensions	Length 220mm x breadth 170mm
Phantom Weight	Less than 10kg when filled with 15cm of simulation tissue

4.7 Universal Device Positioner

ALS-H-E-SET-2

The universal device positioner allows complete freedom of movement of the EUT. Developed to hold a EUT in a free-space scenario any additional loading attributable to the material used in the construction of the positioner has been eliminated. Repeatability has been enhanced through the linear scales which form the design used to indicate positioning for any given test scenario in all major axes. A 15° tilt indicator is included for the of aid cheek to tilt movements for head SAR analysis. Overall uncertainty for measurements has been reduced due to the design of the Universal device positioner, which allows positioning of a device in as near to a free-space scenario as possible, and by providing the means for complete repeatability.

Compliant Standards	IEEE 1528: 2013
Dielectric constant	Less than 5.0
Loss Tangent	Less than 0.05
Number of Axis	6 axis freedom of movement (8 when utilized with ALSAS-10U Workstation)
Translation Along MB Line	± 76.2 mm
Translation Along NF Line	± 38.1 mm
Translation Along Z Axis	± 25.4 mm (expandable up to 500 mm)
Rotation Around MB Line (yaw)	±10°
Rotation Around NF (pitch)	± 30°
Line Rotation (roll)	360° full circle
Maximum Grip Range	0 mm to 150 mm
Material	Resistant to DGBE and all other tissue stimulant materials as listed in IEEE 1528: 2013 Annex C.1.
Tilt Movement	Full movement with built-in 15° gauge



4.8 Test Equipment List

Equipment Type	MFR	Model No.	Serial No.	Last Cal.	Cal. Due Date
Thermo Hygro Recorder	SATO	NS II-Q	1605426	05/25/2017	05/24/2018
Vector Network Analyzer	Agilent	E5071B	MY42402726	12/21/2016	12/20/2017
Dielectric Probe Kit	Agilent	85070E	MY44300124	N/A	N/A
Vector Signal Generator	R&S	SMU200A	102330	03/12/2017	03/11/2018
Power Meter	Anritsu	ML2495A	1116010	05/07/2017	05/06/2018
Power Sensor	Anritsu	MA2411B	34NKF50	05/07/2017	05/06/2018
Data Acquisition Package	Apriel	ALS-DAQ-PAQ-3	110-00220	NA	NA
Apriel Laboratories Probe	Apriel	ALS-E020	266	02/16/2017	02/15/2018
Apriel Reference Dipole 2450MHz	Apriel	ALS-D-2450-S-2	2450-220-00753	01/12/2015	01/11/2018
Boundary Detection Sensor System	Apriel	ALS-PMDPS-3	120-00266	N/A	N/A
Universal Work Station	Apriel	ALS-UWS	100-00153	N/A	N/A
Device Holder 2.0	Apriel	ALS-H-E-SET-2	170-00503	N/A	N/A
Left Ear SAM Phantom	Apriel	ALS-P-SAM-L	130-00305	N/A	N/A
Right Ear SAM Phantom	Apriel	ALS-P-SAM-R	140-00359	N/A	N/A
Universal Phantom	Apriel	ALS-P-UP-1	150-00405	N/A	N/A
Apriel Dipole Spacer	Apriel	ALS-DS-U	250-00903	N/A	N/A

Note: All equipment upon which need to be calibrated are with calibration period of 1 year.

5 Tissue Simulating Liquids

Tissue Dielectric Parameters for Head and Body Phantoms

The head tissue dielectric parameters recommended by the IEEE SCC-34/SC-2 in IEEE1528: 2013 have been incorporated in the following table. These head parameters are derived from planar layer models simulating the highest expected SAR for the dielectric properties and tissue thickness variations in a human head. Other head and body tissue parameters that have not been specified in IEEE1528: 2013 are derived from the tissue dielectric parameters computed from the 4-Cole-Cole equations described in Reference [12] and extrapolated according to the head parameters specified in IEEE1528: 2013.

Target Frequency (MHz)	Parameters(Body) IEEE1528: 2013 OTE 65		Parameters(Head) IEEE1528: 2013 OET65	
	ϵ_r	σ (S/m)	ϵ_r	σ (S/m)
835	55.2	0.97	41.5	0.90
900	55.0	1.05	41.5	0.97
1800 – 2000	53.3	1.52	40.0	1.4
2450	52.7	1.95	39.2	1.8
5800	48.2	6.00	35.3	5.27

(ϵ_r = relative permittivity, σ = conductivity and $\rho = 1000 \text{ kg/m}^3$)

Ingredients (% by weight)	Frequency (MHz)									
	450		835		915		1900		2450	
Tissue Type	Head	Body	Head	Body	Head	Body	Head	Body	Head	Body
Water	38.56	51.16	41.45	52.4	41.05	56.0	54.9	40.4	62.7	73.2
Salt (NaCl)	3.95	1.49	1.45	1.4	1.35	0.76	0.18	0.5	0.5	0.04
Sugar	56.32	46.78	56.0	45.0	56.5	41.76	0.0	58.0	0.0	0.0
HEC	0.98	0.52	1.0	1.0	1.0	1.21	0.0	1.0	0.0	0.0
Bactericide	0.19	0.05	0.1	0.1	0.1	0.27	0.0	0.1	0.0	0.0
Triton X-100	0.0	0.0	0.0	0.0	0.0	0.0	0.0	0.0	36.8	0.0
DGBE	0.0	0.0	0.0	0.0	0.0	0.0	44.92	0.0	0.0	26.7
Dielectric Constant	43.42	58.0	42.54	56.1	42.0	56.8	39.9	54.0	39.8	52.5
Conductivity (S/m)	0.85	0.83	0.91	0.95	1.0	1.07	1.42	1.45	1.88	1.78

Tissue Calibration Result

The dielectric parameters of the liquids were verified prior to the SAR evaluation using Agilent Dielectric Probe Kit 85070E and Agilent E5071B Vector Network Analyzer

Body Tissue Simulant Measurement				
Frequency [MHz]	Description	Dielectric Parameters		Tissue Temp. [°C]
		ϵ_r	σ [s/m]	
	Reference result ± 5% window	52.7 50.065 to 55.335	1.95 1.8525 to 2.0475	N/A
2412MHz	Jun 27, 2017	54.814	1.928	21.5
2437MHz	Jun 27, 2017	54.609	1.930	21.5
2462MHz	Jun 27, 2017	54.482	1.933	21.5

6 SAR Measurement Evaluation

Each system is equipped with one or more system validation kits. These units, together with the predefined measurement procedures within the APREL SAR software, enable the user to conduct the system performance check and system validation. System validation kit includes a dipole, tripod holder to fix it underneath the flat phantom and a corresponding distance holder.

System Setup

In the simplified setup for system evaluation, the DUT is replaced by a calibrated dipole and the power source is replaced by a continuous wave that comes from a signal generator. The calibrated dipole must be placed beneath the flat phantom section of the SAM twin phantom with the correct distance holder. The distance holder should touch the phantom surface with a light pressure at the reference marking and be oriented parallel to the long side of the phantom. The equipment setup is shown below:

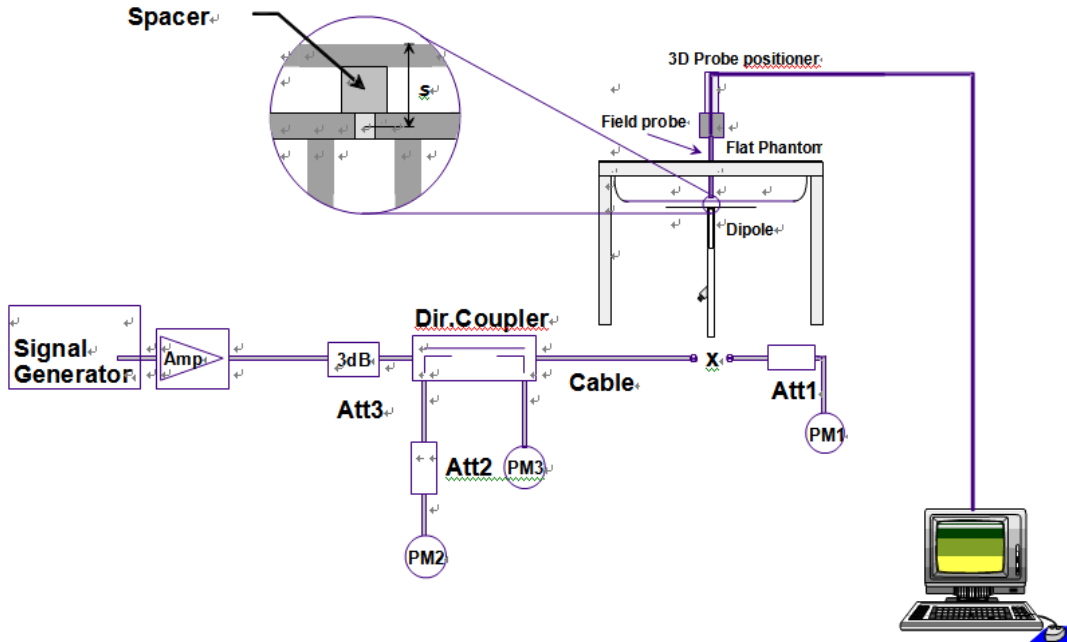

1. Signal Generator
2. Amplifier
3. Directional Coupler
4. Power Meter
5. Calibrated Dipole

Validation Dipoles

The dipoles used is based on the IEEE-1528: 2013 standard, and is complied with mechanical and electrical specifications in line with the requirements of both IEEE and FCC Supplement C. the table below provides details for the mechanical and electrical specifications for the dipoles.

*	Frequency	L (mm)	h (mm)	d (mm)
	700MHz	196.0	112	3.6
	835MHz	161.0	89.8	3.6
	1800MHz	72.0	41.7	3.6
	1900MHz	68.0	39.5	3.6
v	2450MHz	51.5	30.4	3.6
	5250MHz	23.6	14.0	3.6
	5600MHz	21.61	18.22	3.6
	5800MHz	21.6	12.6	3.6

*Note: “V” indicates Frequency used of EUT

The output power on dipole port must be calibrated to 30 dBm (1W) before dipole is connected.

Validation Result



Comparing to the Yearly Calibration SAR value provided by A P R E L , the validation data should be within its specification of 5 %. Table shows the target SAR and measured SAR after normalized to 1W input power. The table below indicates the system performance check can meet the variation criterion and the plots can be referred to Appendix E of this report.

Frequency [MHz]	Description	SAR [w/kg] 1g	SAR [w/kg] 10g	Tissue Temp. [°C]
2450 MHz	Reference result ± 5% window	53.46 50.787 to 56.133	24.89 23.645 to 26.134	N/A
	27-Jun-2017	52.957	24.893	21.5

Note: All SAR values are normalized 1W.

7 DUT Testing Position

Test Positions of Device Relative to Head

This specifies exactly two test positions for the handset against the head phantom, the “cheek” position and the “tilted” position. The handset should be tested in both positions on the left and right sides of the SAM phantom. If the handset construction is such that it cannot be positioned using the handset positioning procedures described in 4.2.2.1 and 4.2.2.2 to represent normal use conditions (e.g., asymmetric handset), alternative alignment procedures should be considered with details provided in the test report.

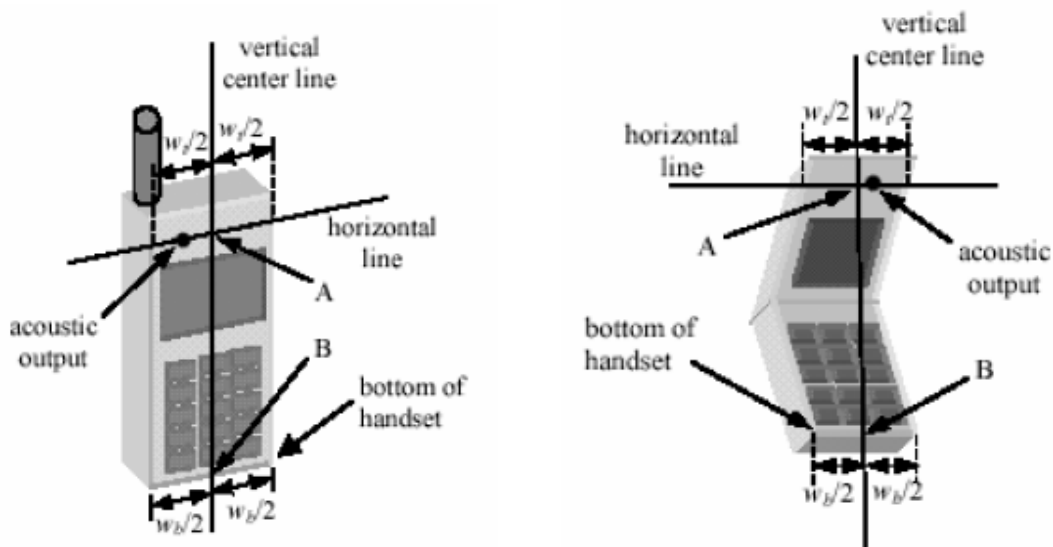

Definition of the “Cheek” Position

The “cheek” position is defined as follows:

- Ready the handset for talk operation, if necessary. For example, for handsets with a cover piece, open the cover. (If the handset can also be used with the cover closed both configurations must be tested.)
- Define two imaginary lines on the handset: the vertical centerline and the horizontal line. The vertical centerline passes through two points on the front side of the handset: the midpoint of the width w_t of the handset at the level of the acoustic output (point A on Figures 4.1a and 4.1b), and the midpoint of the width w_b of the bottom of the handset (point B). The horizontal line is perpendicular to the vertical centerline and passes through the center of the acoustic output (see Figure 4.1a). The two lines intersect at point A. Note that for many handsets, point A coincides with the center of the acoustic output. However, the acoustic output may be located elsewhere on the horizontal line. Also note that the vertical centerline is not necessarily parallel to the front face of the handset (see Figure 4.1b), especially for clamshell handsets, handsets with flip pieces, and other irregularly-shaped handsets.
- Position the handset close to the surface of the phantom such that point A is on the (virtual) extension of the line passing through points RE and LE on the phantom (see Figure 4.2), such that the plane defined by the vertical center line and the horizontal line of the handset is approximately parallel to the sagittal plane of the phantom.

- d. Translate the handset towards the phantom along the line passing through RE and LE until the handset touches the pinna.
- e. While maintaining the handset in this plane, rotate it around the LE-RE line until the vertical centerline is in the plane normal to MB-NF including the line MB (called the reference plane).
- f. Rotate the handset around the vertical centerline until the handset (horizontal line) is symmetrical with respect to the line NF.
- g. While maintaining the vertical centerline in the reference plane, keeping point A on the line passing through RE and LE and maintaining the handset contact with the pinna, rotate the handset about the line NF until any point on the handset is in contact with a phantom point below the pinna (cheek). See Figure 4.2 the physical angles of rotation should be noted.

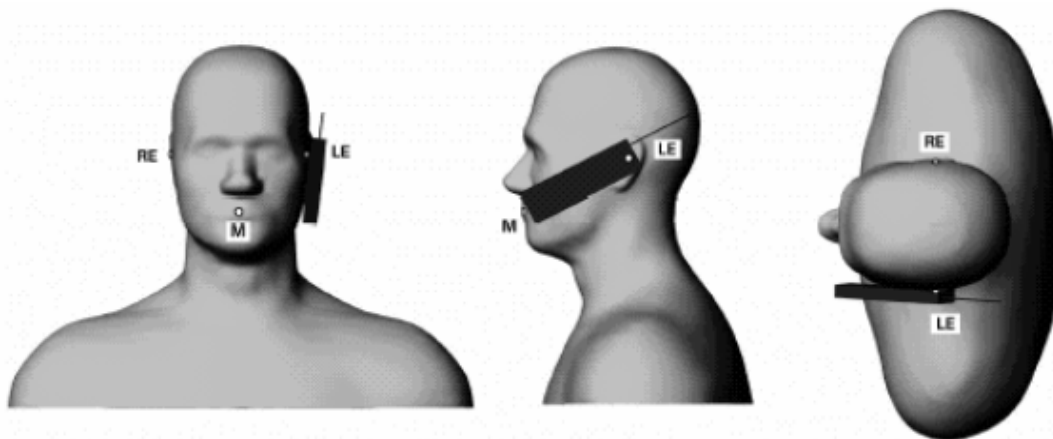

Definition of the “Tilted” Position

The “tilted” position is defined as follows:

- a. Repeat steps (a) – (g) of 4.2.1.1 to place the device in the “cheek position.”
- b. While maintaining the orientation of the handset move the handset away from the pinna along the line passing through RE and LE in order to enable a rotation of the handset by 15 degrees.
- c. Rotate the handset around the horizontal line by 15 degrees.
- d. While maintaining the orientation of the handset, move the handset towards the phantom on a line passing through RE and LE until any part of the handset touches the ear. The tilted position is obtained when the contact is on the pinna. If the contact is at any location other than the pinna (e.g., the antenna with the back of the phantom head), the angle of the handset should be reduced. In this case, the tilted position is obtained if any part of the handset is in contact with the pinna as well as a second part of the handset is contact with the phantom (e.g., the antenna with the back of the head).

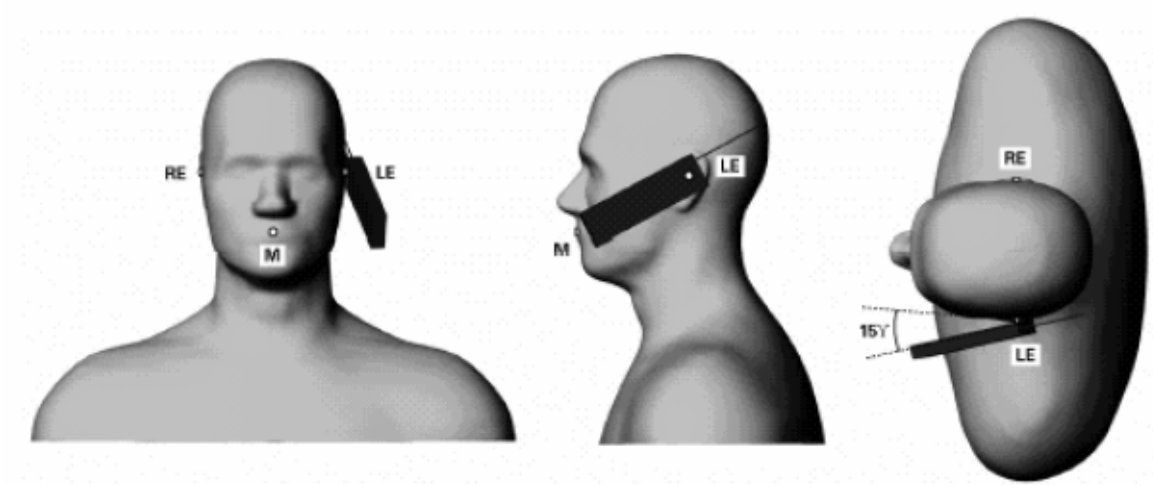

Test Positions for body-worn

Body-worn operating configurations should be tested without the belt-clips and holsters attached to the device and positioned against a flat phantom in normal use configurations. A separation distance of **0** cm between the back of the device and a flat phantom is recommended for testing body-worn SAR compliance under such circumstances. Other separation distance may be use, but not exceed 2.5 cm.

8 SAR Measurement Procedures

The measurement procedures are as follows:

- (a) through software control to continuous transmit
- (b) Set software to maximum output power and data rate
- (c) Measure output power through RF cable and power meter
- (d) Place the DUT in the positions described in the last section
- (e) Set scan area, grid size and other setting on the APREL software
- (f) Taking data for the maximum power on each testing position
- (g) Find out the largest SAR result on these testing positions of each band
- (h) Measure SAR results for the other channels in worst SAR testing position

According to the test standard, the recommended procedure for assessing the peak spatial-average SAR value consists of the following steps:

- (a) Power reference measurement
- (b) Area scan
- (c) Zoom scan
- (d) Power drift measurement

Spatial Peak SAR Evaluation

The procedure for spatial peak SAR evaluation has been implemented according to the test standard. It can be conducted for 1g and 10g, as well as for user-specific masses. The APREL SAR software includes all numerical procedures necessary to evaluate the spatial peak SAR value.

The base for the evaluation is a "cube" measurement. The measured volume must include the 1g and 10g cubes with the highest averaged SAR values. For that purpose, the center of the measured volume is aligned to the interpolated peak SAR value of a previously performed area scan.

The entire evaluation of the spatial peak values is performed within the post-processing engine (SEMCAD). The system always gives the maximum values for the 1g and 10g cubes. The algorithm to find the cube with highest averaged SAR is divided into the following stages:

- (a) Extraction of the measured data (grid and values) from the Zoom Scan
- (b) Calculation of the SAR value at every measurement point based on all stored data (A/D values and measurement parameters)
- (c) Generation of a high-resolution mesh within the measured volume
- (d) Interpolation of all measured values from the measurement grid to the high-resolution grid
- (e) Extrapolation of the entire 3-D field distribution to the phantom surface over the distance from sensor to surface
- (f) Calculation of the averaged SAR within masses of 1g and 10g

Scan Procedures

First Area Scan is used to locate the approximate location(s) of the local peak SAR value(s). The measurement grid within an Area Scan is defined by the grid extent, grid step size and grid offset. Next, in order to determine the EM field distribution in a three-dimensional spatial extension, Zoom Scan is required. The Zoom Scan measures 5x5x7 points with step size 8, 8 and 5 mm for 300 MHz to 3 GHz. The Zoom Scan is performed around the highest E-field value to determine the averaged SAR-distribution over 10 g.

SAR Averaged Methods

In APREL, the interpolation and extrapolation are both based on the modified Quadratic Shepard's method. The interpolation scheme combines a least-square fitted function method and a weighted average method which are the two basic types of computational interpolation and approximation.

Extrapolation routines are used to obtain SAR values between the lowest measurement points and the inner phantom surface. The extrapolation distance is determined by the surface detection distance and the probe sensor offset. The uncertainty increases with the extrapolation distance. To keep the uncertainty within 1% for the 1 g and 10 g cubes, the extrapolation distance should not be larger than 5 mm.

9 SAR Test Results

9.1 Conducted power table:

Wifi:

802.11b

Cable loss = 0	Output Power		Limit (dBm)
CH	Detector		
	PK (dBm)	AV (dBm)	
Low	13.19	10.7	30.00
Mid	13.43	10.94	
High	13.87	11.21	

802.11g

Cable loss = 0	Output Power		Limit (dBm)
CH	Detector		
	PK (dBm)	AV (dBm)	
Low	21.52	11.97	30.00
Mid	22.02	12.53	
High	22.43	12.92	

802.11n HT20

Cable loss = 0	Output Power		Limit (dBm)
CH	Detector		
	PK (dBm)	AV (dBm)	
Low	21.01	11.37	30.00
Mid	21.55	11.88	
High	21.98	12.31	

BT:

BDR Mode

Frequency (MHz)	Peak Reading Power (dBm)	Cable Loss	Output Power (dBm)	Output Power (W)	Limit (W)
Low	-0.06	0.00	-0.06	0.00099	1
Mid	0.11	0.00	0.11	0.00103	1
High	0.65	0.00	0.65	0.00116	1

EDR 2M Mode

Frequency (MHz)	Peak Reading Power (dBm)	Cable Loss	Output Power (dBm)	Output Power (W)	Limit (W)
Low	-2.72	0.00	-2.72	0.00053	0.125
Mid	-2.12	0.00	-2.12	0.00061	0.125
High	-1.45	0.00	-1.45	0.00072	0.125

EDR 3M Mode

Frequency (MHz)	Peak Reading Power (dBm)	Cable Loss	Output Power (dBm)	Output Power (W)	Limit (W)
Low	-2.27	0.00	-2.27	0.00059	0.125
Mid	-1.67	0.00	-1.67	0.00068	0.125
High	-1.03	0.00	-1.03	0.00079	0.125

LE Mode

Frequency (MHz)	Peak Reading Power (dBm)	Cable Loss	Output Power (dBm)	Output Power (W)	Limit (W)
Low	-0.08	0.00	-0.08	0.00098	1
Mid	0.19	0.00	0.19	0.00105	1
High	0.83	0.00	0.83	0.00121	1

9.2 Test Records for Body SAR Test

1. According KDB447498 the maximum output power channel is used for SAR testing and reduction

2. According KDB 248227:

a) When the reported SAR of the initial test position is ≤ 0.4 W/kg, further SAR measurement is not required for the other (remaining) test positions in that exposure configuration and 802.11 transmission mode combinations within the frequency band or aggregated band. SAR is also not required for that exposure configuration in the subsequent test configuration(s).

b) When the reported SAR of the initial test position is > 0.4 W/kg, SAR is repeated for the 802.11 transmission mode configuration tested in the initial test position using subsequent highest extrapolated or estimated 1-g SAR conditions determined by area scans or next closest/smallest test separation distance and maximum RF coupling test positions based on manufacturer justification, on the highest maximum output power channel, until the reported SAR is ≤ 0.8 W/kg or all required test positions (left, right, touch, tilt or subsequent surfaces and edges) are tested.17

c) For all positions/configurations tested using the initial test position and subsequent test positions, when the reported SAR is > 0.8 W/kg, SAR is measured for these test positions/configurations on the subsequent next highest measured output power channel(s) until the reported SAR is ≤ 1.2 W/kg or all required channels are tested. Additional power measurements may be required for this step, which should be limited to those necessary for identifying the subsequent highest output power channels.

3. SAR evaluation is required if the separation distance between the user and the antenna and/or radiating element of the device is less than or equal to 20 cm, According KDB 447498 Standalone SAR test exclusion considerations:

For test separation distance < 50 mm

$[(\text{max. power of channel, including tune-up tolerance, mW}) / (\text{min. test separation distance, mm})] \cdot [\sqrt{f(\text{GHz})}] \leq 3.0$ for 1-g SAR, and ≤ 7.5 for 10-g extremity SAR, where

- $f(\text{GHz})$ is the RF channel transmit frequency in GHz
- Power and distance are rounded to the nearest mW and mm before calculation
- The result is rounded to one decimal place for comparison

For test separation distance > 50 mm

1) $\{[\text{Power allowed at numeric threshold for 50 mm in step a)}] + [(\text{test separation distance} - 50 \text{ mm}) \cdot (f(\text{MHz})/150)]\}$ mW, for 100 MHz to 1500 MHz

2) $\{[\text{Power allowed at numeric threshold for 50 mm in step a)}] + [(\text{test separation distance} - 50 \text{ mm}) \cdot 10]\}$ mW, for > 1500 MHz and ≤ 6 GHz

or complied KDB 447498 Appendix A and B Table 1

Table 1

For KDB447498

test separation distance <50mm

MHz	5	10	15	20	25	mm
150	39	77	116	155	194	<i>SAR Test Exclusion Threshold (mW)</i>
300	27	55	82	110	137	
450	22	45	67	89	112	
835	16	33	49	66	82	
900	16	32	47	63	79	
1500	12	24	37	49	61	
1900	11	22	33	44	54	
2450	10	19	29	38	48	
3600	8	16	24	32	40	
5200	7	13	20	26	33	
5400	6	13	19	26	32	
5800	6	12	19	25	31	
MHz	30	35	40	45	50	
150	232	271	310	349	387	<i>SAR Test Exclusion Threshold (mW)</i>
300	164	192	219	246	274	
450	134	157	179	201	224	
835	98	115	131	148	164	
900	95	111	126	142	158	
1500	73	86	98	110	122	
1900	65	76	87	98	109	
2450	57	67	77	86	96	
3600	47	55	63	71	79	
5200	39	46	53	59	66	
5400	39	45	52	58	65	
5800	37	44	50	56	62	

test separation distance >50mm

MHz	50	60	70	80	90	100	110	120	130	140	150	160	170	180	190	mm
100	474	481	487	494	501	507	514	521	527	534	541	547	554	561	567	mW
150	387	397	407	417	427	437	447	457	467	477	487	497	507	517	527	
300	274	294	314	334	354	374	394	414	434	454	474	494	514	534	554	
450	224	254	284	314	344	374	404	434	464	494	524	554	584	614	644	
835	164	220	275	331	387	442	498	554	609	665	721	776	832	888	943	
900	158	218	278	338	398	458	518	578	638	698	758	818	878	938	998	
1500	122	222	322	422	522	622	722	822	922	1022	1122	1222	1322	1422	1522	
1900	109	209	309	409	509	609	709	809	909	1009	1109	1209	1309	1409	1509	
2450	96	196	296	396	496	596	696	796	896	996	1096	1196	1296	1396	1496	
3600	79	179	279	379	479	579	679	779	879	979	1079	1179	1279	1379	1479	
5200	66	166	266	366	466	566	666	766	866	966	1066	1166	1266	1366	1466	
5400	65	165	265	365	465	565	665	765	865	965	1065	1165	1265	1365	1465	
5800	62	162	262	362	462	562	662	762	862	962	1062	1162	1262	1362	1462	

4. SAR test worst modulation and Mode

4.1. Bluetooth SAR testing was selected BDR modulation, due to its highest average output power

5. SAR Test Exclusion evaluate Table:

Exposure Position	Testing required	BT	2.4GHz WLAN
Front	Yes/no	No	No
Bottom	Yes/no	Yes	Yes
Edge of Right	Yes/no	Yes	Yes
Edge of Left	Yes/no	No	No
Top	Yes/no	No	No
Edge of Bottom	Yes/no	No	No

Antenna Location

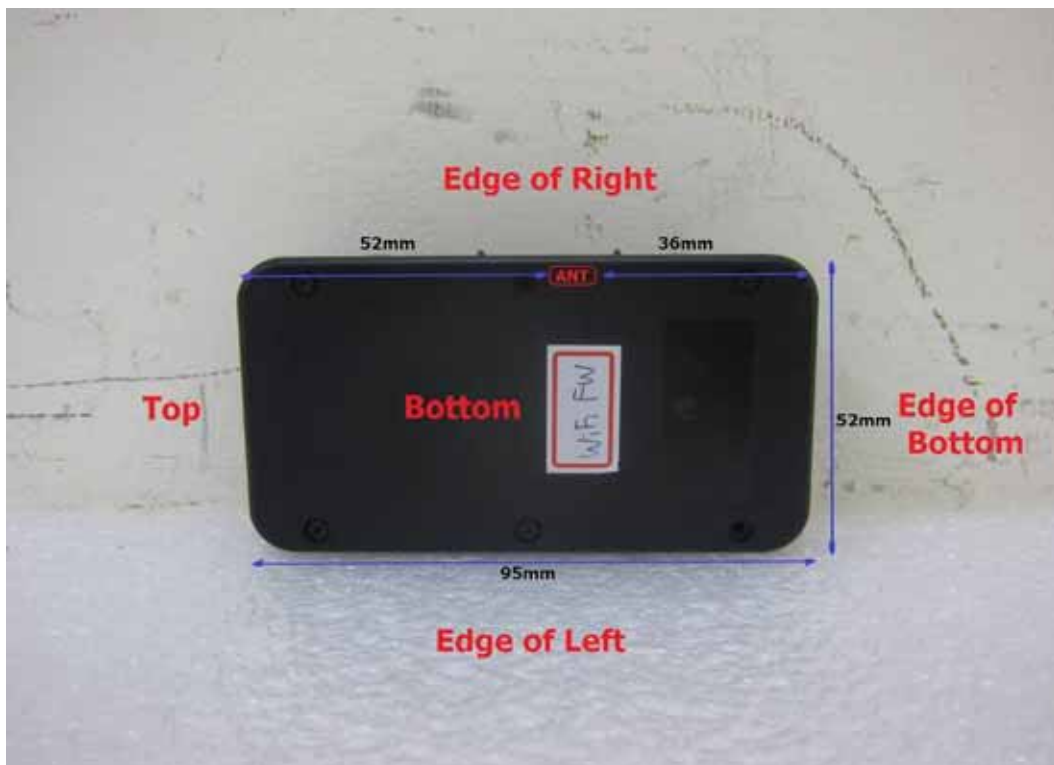

Ambient Temperature (°C) : 21.5	Relative Humidity (%):60
Liquid Temperature (°C) : 21.5	Depth of Liquid (cm):>15

Stand- Alone SAR

DataNo.	Mode	Band	Test Position	Separation Distance (cm)	Channel (MHz)	SAR 1g(W/kg)
1	Wifi	802.11b	Front	0	2462	0.337
2	Wifi	802.11b	Bottom	0	2462	0.055
3	Wifi	802.11b	Edge of Right	0	2462	0.596
4	Wifi	802.11g	Front	0	2462	0.534
5	Wifi	802.11g	Bottom	0	2462	0.108
6	Wifi	802.11g	Edge of Right	0	2462	0.776
7	Wifi	802.11g	Edge of Right	0	2412	0.556
8	Wifi	802.11g	Edge of Right	0	2437	0.683
9	Wifi	802.11n 20	Edge of Right	0	2462	0.686
10	BT	BDR	Edge of Right	0	2480	0.001
11	BT	BLE	Edge of Right	0	2480	0.001

Note : Reference to Appendix D for worst Raw data

FCC Scaled up SAR

Data No:	Band	Test Mode	Test Position	Separation Distance (cm)	Ch.	Measured Avg Power (dBm)	Tune-up maximum limit(dBm)	Scaling factor	duty cycle (%)	duty fact	Measured SAR 1g(W/kg)	Scaled SAR 1g(W/kg)
1	Wifi	802.11b	Front	0.0	11	11.21	12.50	1.35	99.00	1.01	0.337	0.458
2	Wifi	802.11b	Bottom	0.0	11	11.21	12.50	1.35	99.00	1.01	0.055	0.075
3	Wifi	802.11b	Edge of Right	0.0	11	11.21	12.50	1.35	99.00	1.01	0.596	0.810
4	Wifi	802.11g	Front	0.0	11	12.92	13.50	1.14	99.00	1.01	0.534	0.616
5	Wifi	802.11g	Bottom	0.0	11	12.92	13.50	1.14	99.00	1.01	0.108	0.125
6	Wifi	802.11g	Edge of Right	0.0	11	12.92	13.50	1.14	99.00	1.01	0.776	0.896
7	Wifi	802.11g	Edge of Right	0.0	1	12.92	13.50	1.14	99.00	1.01	0.556	0.642
8	Wifi	802.11g	Edge of Right	0.0	6	12.92	13.50	1.14	99.00	1.01	0.683	0.788
9	Wifi	802.11n 20	Edge of Right	0.0	11	12.31	12.50	1.04	99.00	1.01	0.686	0.724
10	BT	BDR	Edge of Right	0.0	Hopping	0.65	1.50	1.22	70.00	1.43	0.001	0.002
11	BT	BLE	Edge of Right	0.0	Hopping	0.83	1.50	1.17	70.00	1.43	0.001	0.002

10 Exposure Assessment Measurement Uncertainty

Source of Uncertainty	Tolerance Value	Probability Distribution	Divisor	c_i^1 (1-g)	c_i^1 (10-g)	Standard Uncertainty (1-g) %	Standard Uncertainty (10-g) %
Measurement System							
Probe Calibration	3.5	normal	1	1	1	3.5	3.5
Axial Isotropy	3.7	rectangular	$\sqrt{3}$	$(1-cp)^{1/2}$	$(1-cp)^{1/2}$	2.1	2.1
Hemispherical Isotropy	10.9	rectangular	$\sqrt{3}$	\sqrt{cp}	\sqrt{cp}	6.3	6.3
Boundary Effect	1	rectangular	$\sqrt{3}$	1	1	0.6	0.6
Linearity	4.7	rectangular	$\sqrt{3}$	1	1	2.7	2.7
System Detection Limit	1	rectangular	$\sqrt{3}$	1	1	0.6	0.6
Modulation response	3	rectangular	$\sqrt{3}$	1	1	1.7	1.7
Readout Electronics	1	normal	1	1	1	1	1
Response Time	0.8	rectangular	$\sqrt{3}$	1	1	0.5	0.5
Integration Time	1.7	rectangular	$\sqrt{3}$	1	1	1.0	1.0
RF Ambient Condition -noise	3	rectangular	$\sqrt{3}$	1	1	1.7	1.7
RF ambient conditions—reflections	3	rectangular	$\sqrt{3}$	1	1	1.7	1.7
Probe positioner mechanical tolerance	0.4	rectangular	$\sqrt{3}$	1	1	0.2	0.2
Probe Positioning with respect to Phantom Shell	2.9	rectangular	$\sqrt{3}$	1	1	1.7	1.7
Extrapolation, interpolation, and integration algorithms for max. SAR evaluation	3.7	rectangular	$\sqrt{3}$	1	1	2.1	2.1
Test Sample Related							
Test Sample Positioning	4	normal	1	1	1	4.0	4.0
Device Holder Uncertainty	2	normal	1	1	1	2.0	2.0
Output power variation—SAR drift measurement	1.2	rectangular	$\sqrt{3}$	1	1	0.7	0.7

SAR scaling	2	rectangular	$\sqrt{3}$	1	1	1.2	1.2
Phantom and Tissue Parameters							
Phantom shell uncertainty—shape, thickness and permittivity	3.4	rectangular	$\sqrt{3}$	1	1	2.0	2.0
Uncertainty in SAR correction for deviations in permittivity and conductivity	1.9	normal	1	1	1	1.9	1.9
Liquid Conductivity measurement	2.9	normal	1	1	1	2.9	2.9
Liquid Permittivity measurement	3.3	normal	1	1	1	3.3	3.3
Liquid Conductivity—temperature	5	rectangular	$\sqrt{3}$	0.7	0.5	2.9	2.9
Liquid Permittivity—temperature	5	rectangular	$\sqrt{3}$	0.6	0.5	2.9	2.9
Combined Uncertainty		RSS				12.2	12.2
Combined Uncertainty (coverage factor=2)		Normal(k=2)				24.4	24.4

Appendix A Test Setup Photos

Front



Bottom



Edge of Right



Edge of Left

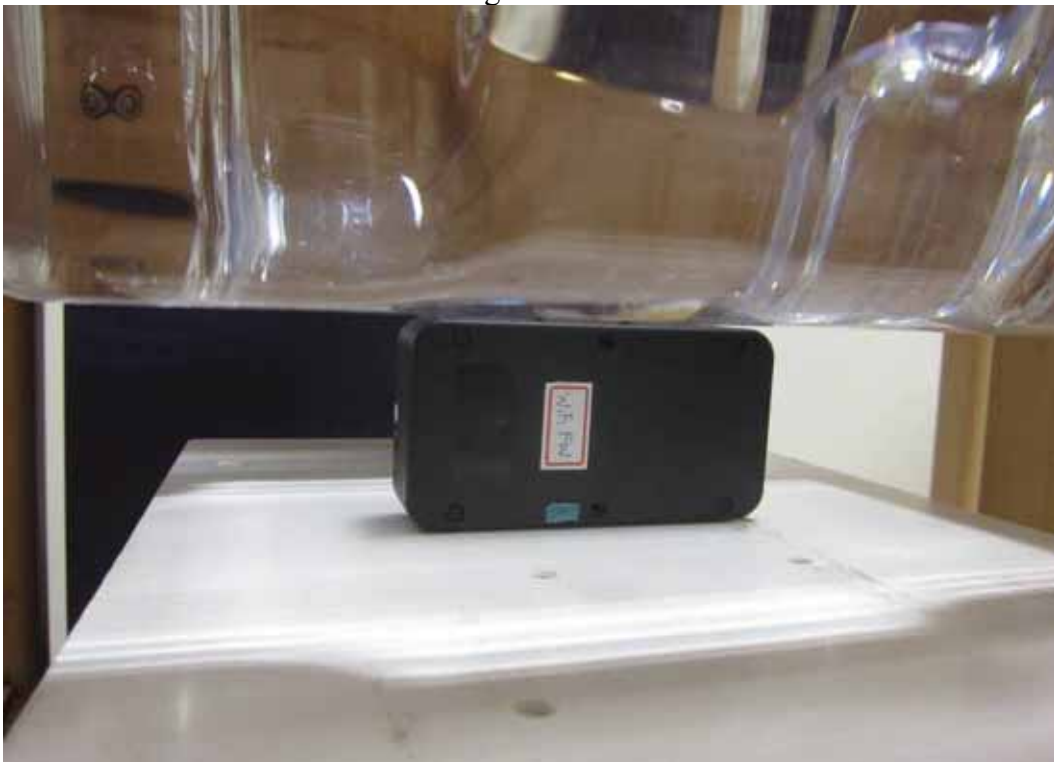

Top

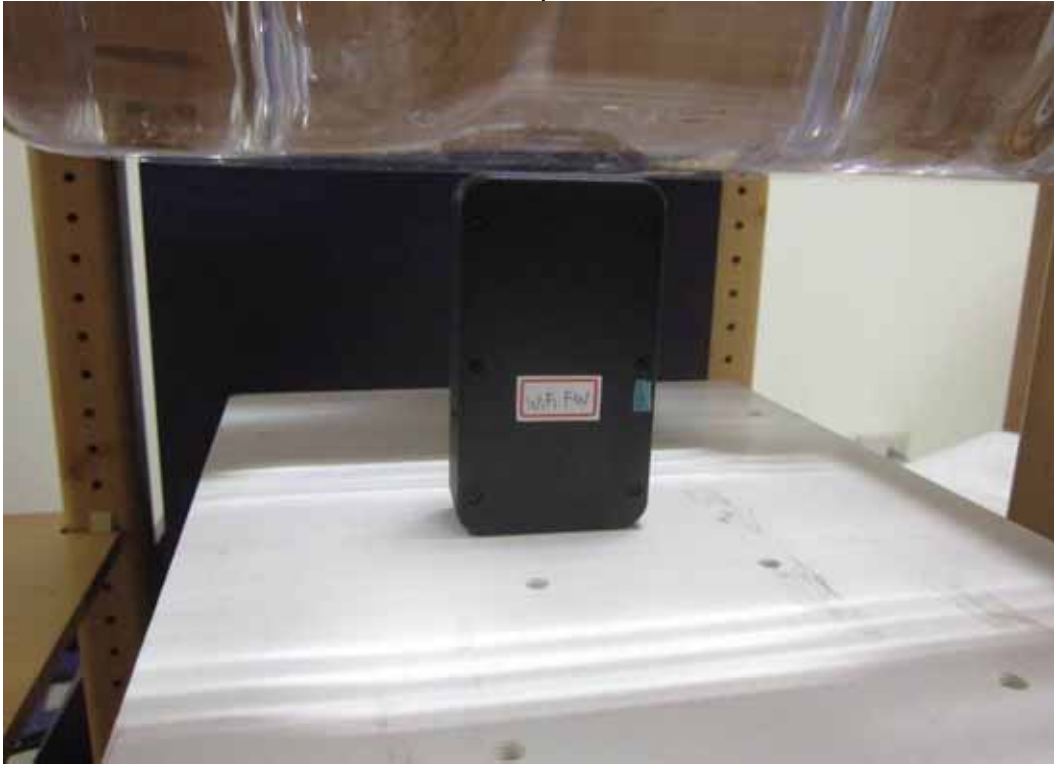

Edge of Bottom



Tissue altitude(15cm) for Below 3G



Appendix B DUT Photos

Refer to FCC Part15.247 report.

Appendix C System Validation

Refer to Appendix C

Appendix D SAR Worst Measurement Data

Refer to Appendix D

Appendix E Probe Calibration Certificate

Refer to Appendix E

Appendix F Dipole Calibration Certificate

Refer to Appendix F

Appendix G System Check (Annual)

Refer to Appendix G

~ end of Report ~

Appendix C: System Performance Check

Report Date : 27-Jun-2017
By Operator : Dino Chen
DUT : Dipole
Frequency : 2450.00 MHz
Max. Transmit Pwr : 1 W

APREL ALSAS-10U System Description

Phantom Data

Name : Universal Phantom
Type : ALS-P-UP-1

Tissue Data

Type : Head/Body
Frequency : 2450.00 MHz

Probe Data

Name : E-field Probe
Model : ALS-E-020
Serial No. : 266
Last Calib. Date : 16-Feb-2017

Measurement Data

Crest Factor : 1
Scan Type : Complete
Tissue Temp. : 21.50 °C
Ambient Temp. : 21.50 °C
Area Scan : 9x9x1 : Measurement x=10mm, y=10mm, z=4mm
Zoom Scan : 5x5x8 : Measurement x=8mm, y=8mm, z=4mm
Separation : 1cm

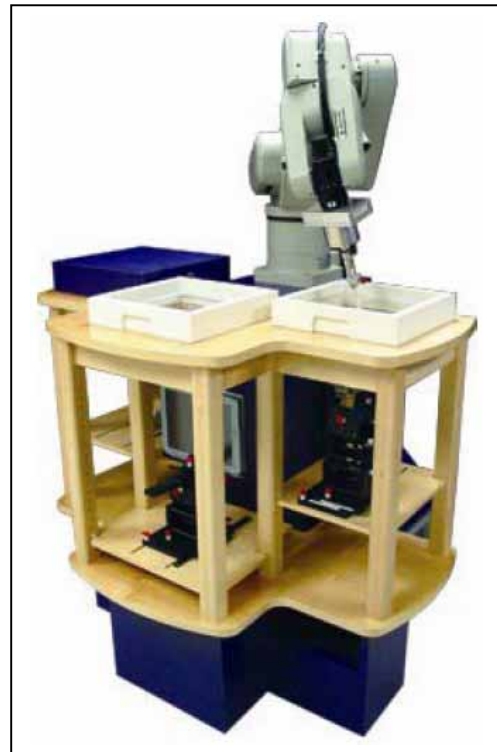

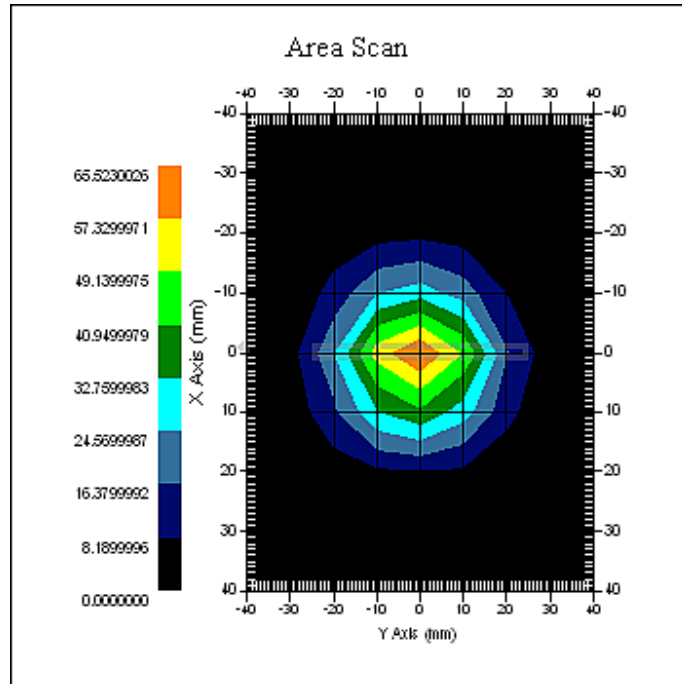

1 gram SAR value : 52.957 W/kg
10 gram SAR value : 24.893 W/kg
Area Scan Peak SAR : 65.429 W/kg
Zoom Scan Peak SAR : 104.088 W/kg

Appendix D: SAR Measurement Data

Data No.	Mode	Band	Test Position	Separation Distance (cm)	Channel	SAR 1g(W/kg)
1	Wifi	802.11b	Front	0	11	0.337
2	Wifi	802.11b	Bottom	0	11	0.055
3	Wifi	802.11b	Edge of Right	0	11	0.596
4	Wifi	802.11g	Front	0	11	0.534
5	Wifi	802.11g	Bottom	0	11	0.108
6	Wifi	802.11g	Edge of Right	0	11	0.776
7	Wifi	802.11g	Edge of Right	0	1	0.556
8	Wifi	802.11g	Edge of Right	0	6	0.683
9	Wifi	802.11n 20	Edge of Right	0	11	0.686
10	BT	BDR	Edge of Right	0	Hopping	0.001
11	BT	BLE	Edge of Right	0	Hopping	0.001



Data No. 1:

Report Date : 27-Jun-2017
By Operator : 123
Measurement Date : 27-Jun-2017
Starting Time : 27-Jun-2017 09:42:21 PM
End Time : 27-Jun-2017 10:02:17 PM
Scanning Time : 1196 secs
Product Data
Device Name : 17LR138
Serial No. : NA
Type : Other
Model : DPB30
Frequency : 2450.00 MHz
Max. Transmit Pwr : 0.25 W
Drift Time : 1 min(s)
Length : 52 mm
Width : 95 mm
Depth : 27 mm
Antenna Type : Internal
Orientation : Touch
Power Drift-Start : 0.200 W/kg
Power Drift-Finish: 0.197 W/kg
Power Drift (%) : -1.379
Picture : C:\alsas\bitmap\Device-8.bmp

Phantom Data
Name : APREL-Uni
Type : Uni-Phantom
Size (mm) : 280 x 280 x 200
Serial No. : User Define
Location : Center
Description : Uni-Phantom

Tissue Data
Type : BODY
Serial No. : 2450B
Frequency : 2450.00 MHz
Last Calib. Date : 27-Jun-2017
Temperature : 21.50 °C
Ambient Temp. : 21.50 °C
Humidity : 62.00 RH%
Epsilon (Dielectric Constant): 54.51
Sigma : 1.93 S/m
Density : 1000.00 kg/cu. m



Probe Data

Name : E-field
Model : E-020
Type : E-Field Triangle
Serial No. : 266
Last Calib. Date : 16-Feb-2017
Frequency : 2450.00 MHz
Duty Cycle Factor (CreF): 1
Conversion Factor : 5
Probe Sensitivity : 1.21 1.21 1.20 $\mu\text{V}/(\text{V}/\text{m})^2$
Compression Point : 95.00 mV
Offset : 1.56 mm

Measurement Data

Crest Factor : 1
Scan Type : Complete
Tissue Temp. : 21.50 °C
Ambient Temp. : 21.50 °C
Set-up Date : 27-Jun-2017
Set-up Time : 9:28:02 AM
Area Scan : 7x9x1 : Measurement x=10mm, y=10mm, z=4mm
Zoom Scan : 5x5x8 : Measurement x=8mm, y=8mm, z=4mm

Other Data

DUT Position : Touch
Separation : 0
Channel : High

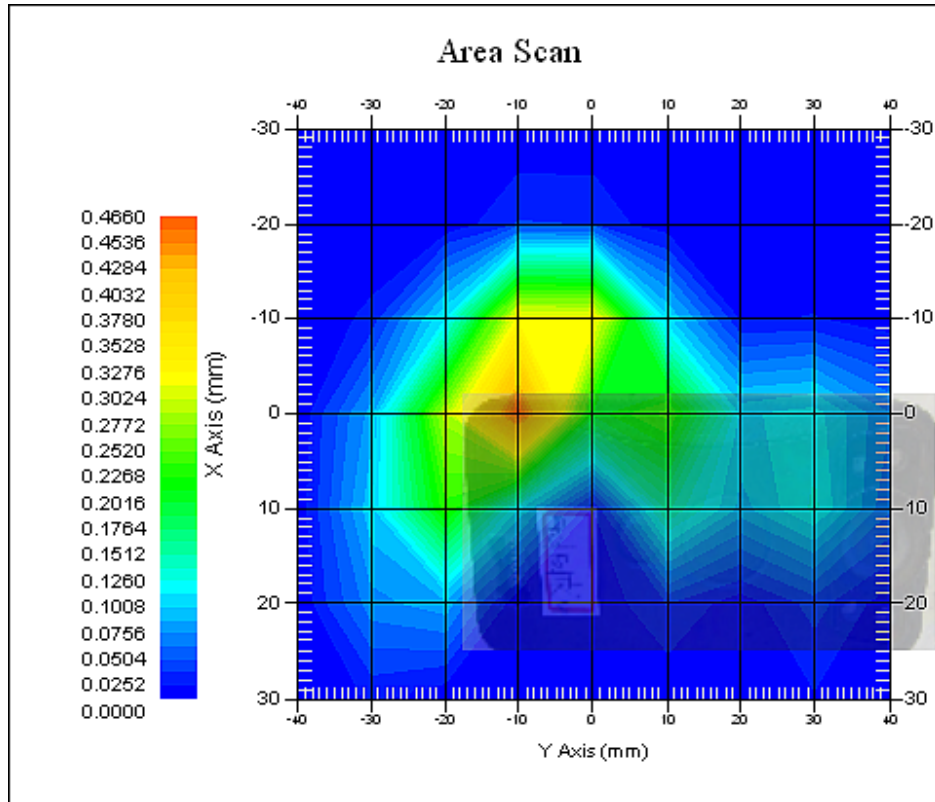

The system detected 1 maxima.
 Selected highest maxima # = 1.
 Maxima #1 coordinates: X = 0.030, Y = -10.000
 1 gram SAR value : 0.337 W/kg
 Area Scan Peak SAR : 0.466 W/kg
 Zoom Scan Peak SAR : 0.890 W/kg

Maxima Summary:
 Maxima #1
 Maxima coordinates: X = 0.030, Y = -10.000
 1 gram SAR value : 0.337 W/kg
 Area Scan Peak SAR : 0.466 W/kg
 Zoom Scan Peak SAR : 0.890 W/kg



Data No. 2:

Report Date : 27-Jun-2017
By Operator : 123
Measurement Date : 27-Jun-2017
Starting Time : 27-Jun-2017 07:46:39 PM
End Time : 27-Jun-2017 08:06:28 PM
Scanning Time : 1189 secs
Product Data
Device Name : 17LR138
Serial No. : NA
Type : Other
Model : DPB30
Frequency : 2450.00 MHz
Max. Transmit Pwr : 0.25 W
Drift Time : 1 min(s)
Length : 52 mm
Width : 95 mm
Depth : 27 mm
Antenna Type : Internal
Orientation : Touch
Power Drift-Start : 0.001 W/kg
Power Drift-Finish: 0.000 W/kg
Power Drift (%) : 0.000
Picture : C:\alsas\bitmap\Device-11.bmp

Phantom Data
Name : APREL-Uni
Type : Uni-Phantom
Size (mm) : 280 x 280 x 200
Serial No. : User Define
Location : Center
Description : Uni-Phantom

Tissue Data
Type : BODY
Serial No. : 2450B
Frequency : 2450.00 MHz
Last Calib. Date : 27-Jun-2017
Temperature : 21.50 °C
Ambient Temp. : 21.50 °C
Humidity : 62.00 RH%
Epsilon (Dielectric Constant): 54.51
Sigma : 1.93 S/m
Density : 1000.00 kg/cu. m



Probe Data

Name : E-field
Model : E-020
Type : E-Field Triangle
Serial No. : 266
Last Calib. Date : 16-Feb-2017
Frequency : 2450.00 MHz
Duty Cycle Factor (CreF) : 1
Conversion Factor : 5
Probe Sensitivity : 1.21 1.21 1.20 $\mu\text{V}/(\text{V}/\text{m})^2$
Compression Point : 95.00 mV
Offset : 1.56 mm

Measurement Data

Crest Factor : 1
Scan Type : Complete
Tissue Temp. : 21.50 °C
Ambient Temp. : 21.50 °C
Set-up Date : 27-Jun-2017
Set-up Time : 9:28:02 AM
Area Scan : 7x9x1 : Measurement x=10mm, y=10mm, z=4mm
Zoom Scan : 5x5x8 : Measurement x=8mm, y=8mm, z=4mm

Other Data

DUT Position : Touch
Separation : 0
Channel : High

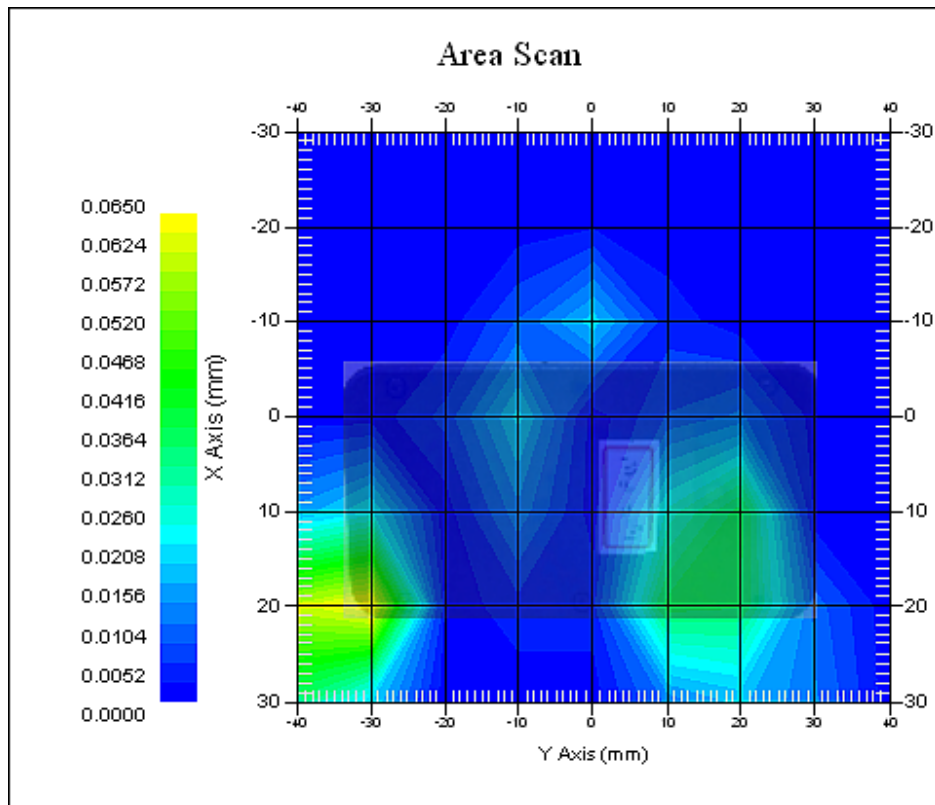

The system detected 1 maxima.
Selected highest maxima # = 1.
Maxima #1 coordinates: X = 20.070, Y = -38.000
1 gram SAR value : 0.055 W/kg
Area Scan Peak SAR : 0.065 W/kg
Zoom Scan Peak SAR : 0.150 W/kg

Maxima Summary:
Maxima #1
Maxima coordinates: X = 20.070, Y = -38.000
1 gram SAR value : 0.055 W/kg
Area Scan Peak SAR : 0.065 W/kg
Zoom Scan Peak SAR : 0.150 W/kg



Data No. 3:

Report Date : 27-Jun-2017
By Operator : 123
Measurement Date : 27-Jun-2017
Starting Time : 27-Jun-2017 05:40:42 PM
End Time : 27-Jun-2017 06:00:33 PM
Scanning Time : 1191 secs
Product Data
Device Name : 17LR138
Serial No. : NA
Type : Other
Model : DPB30
Frequency : 2450.00 MHz
Max. Transmit Pwr : 0.25 W
Drift Time : 1 min(s)
Length : 27 mm
Width : 95 mm
Depth : 52 mm
Antenna Type : Internal
Orientation : Touch
Power Drift-Start : 0.117 W/kg
Power Drift-Finish: 0.166 W/kg
Power Drift (%) : 4.444
Picture : C:\alsas\bitmap\Device-7.bmp

Phantom Data
Name : APREL-Uni
Type : Uni-Phantom
Size (mm) : 280 x 280 x 200
Serial No. : User Define
Location : Center
Description : Uni-Phantom

Tissue Data
Type : BODY
Serial No. : 2450B
Frequency : 2450.00 MHz
Last Calib. Date : 27-Jun-2017
Temperature : 21.50 °C
Ambient Temp. : 21.50 °C
Humidity : 62.00 RH%
Epsilon (Dielectric Constant): 54.51
Sigma : 1.93 S/m
Density : 1000.00 kg/cu. m



Probe Data

Name : E-field
Model : E-020
Type : E-Field Triangle
Serial No. : 266
Last Calib. Date : 16-Feb-2017
Frequency : 2450.00 MHz
Duty Cycle Factor (CreF): 1
Conversion Factor : 5
Probe Sensitivity : 1.21 1.21 1.20 $\mu\text{V}/(\text{V}/\text{m})^2$
Compression Point : 95.00 mV
Offset : 1.56 mm

Measurement Data

Crest Factor : 1
Scan Type : Complete
Tissue Temp. : 21.50 °C
Ambient Temp. : 21.50 °C
Set-up Date : 27-Jun-2017
Set-up Time : 9:28:02 AM
Area Scan : 7x9x1 : Measurement x=10mm, y=10mm, z=4mm
Zoom Scan : 5x5x8 : Measurement x=8mm, y=8mm, z=4mm

Other Data

DUT Position : Touch
Separation : 0
Channel : High

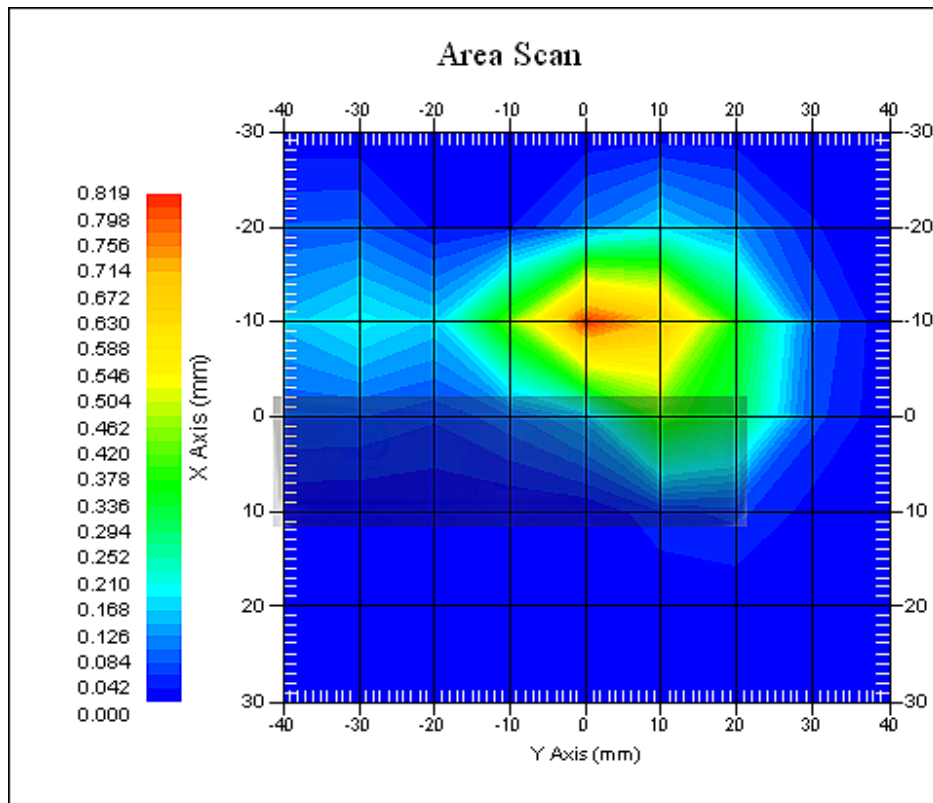

The system detected 1 maxima.
Selected highest maxima # = 1.
Maxima #1 coordinates: X = -9.930, Y = 0.000
1 gram SAR value : 0.596 W/kg
Area Scan Peak SAR : 0.817 W/kg
Zoom Scan Peak SAR : 1.701 W/kg

Maxima Summary:

Maxima #1
Maxima coordinates: X = -9.930, Y = 0.000
1 gram SAR value : 0.596 W/kg
Area Scan Peak SAR : 0.817 W/kg
Zoom Scan Peak SAR : 1.701 W/kg



Data No. 4:

Report Date : 27-Jun-2017
By Operator : 123
Measurement Date : 27-Jun-2017
Starting Time : 27-Jun-2017 01:29:15 PM
End Time : 27-Jun-2017 01:49:23 PM
Scanning Time : 1208 secs
Product Data
Device Name : 17LR138
Serial No. : NA
Type : Other
Model : DPB30
Frequency : 2450.00 MHz
Max. Transmit Pwr : 0.25 W
Drift Time : 1 min(s)
Length : 52 mm
Width : 95 mm
Depth : 27 mm
Antenna Type : Internal
Orientation : Touch
Power Drift-Start : 0.339 W/kg
Power Drift-Finish: 0.347 W/kg
Power Drift (%) : 2.315
Picture : C:\alsas\bitmap\Device-8.bmp

Phantom Data
Name : APREL-Uni
Type : Uni-Phantom
Size (mm) : 280 x 280 x 200
Serial No. : User Define
Location : Center
Description : Uni-Phantom

Tissue Data
Type : BODY
Serial No. : 2450B
Frequency : 2450.00 MHz
Last Calib. Date : 27-Jun-2017
Temperature : 21.50 °C
Ambient Temp. : 21.50 °C
Humidity : 62.00 RH%
Epsilon (Dielectric Constant): 54.51
Sigma : 1.93 S/m
Density : 1000.00 kg/cu. m



Probe Data

Name : E-field
Model : E-020
Type : E-Field Triangle
Serial No. : 266
Last Calib. Date : 16-Feb-2017
Frequency : 2450.00 MHz
Duty Cycle Factor (CreF): 1
Conversion Factor : 5
Probe Sensitivity : 1.21 1.21 1.20 $\mu\text{V}/(\text{V}/\text{m})^2$
Compression Point : 95.00 mV
Offset : 1.56 mm

Measurement Data

Crest Factor : 1
Scan Type : Complete
Tissue Temp. : 21.50 °C
Ambient Temp. : 21.50 °C
Set-up Date : 27-Jun-2017
Set-up Time : 9:28:02 AM
Area Scan : 7x9x1 : Measurement x=10mm, y=10mm, z=4mm
Zoom Scan : 5x5x8 : Measurement x=8mm, y=8mm, z=4mm

Other Data

DUT Position : Touch
Separation : 0
Channel : High

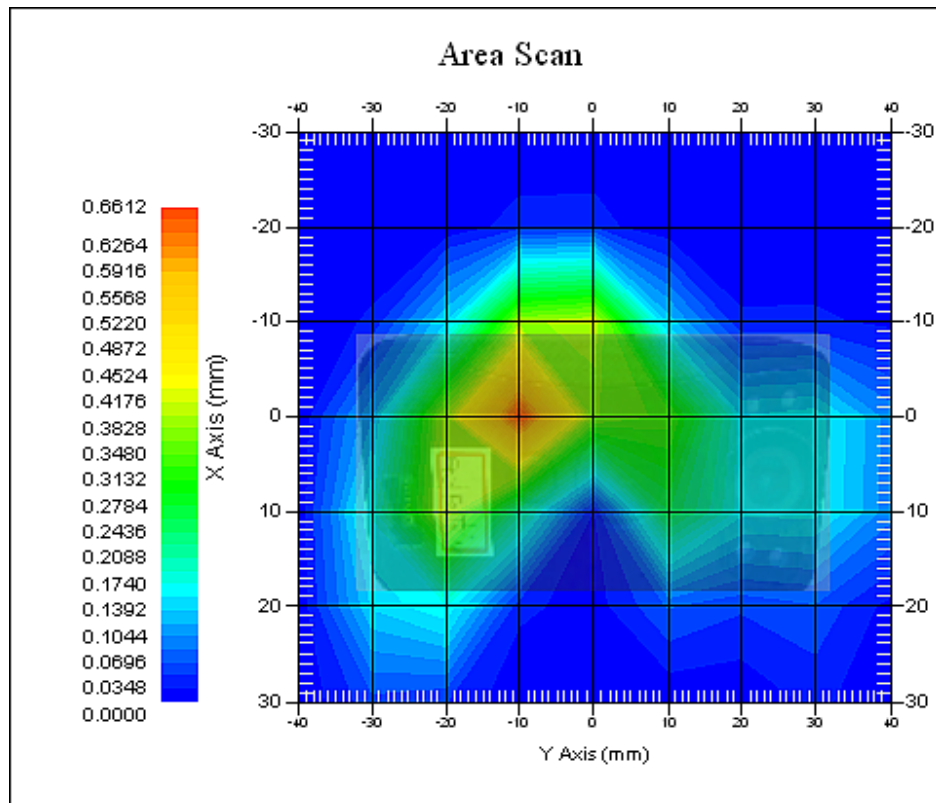

The system detected 1 maxima.
 Selected highest maxima # = 1.
 Maxima #1 coordinates: X = 0.140, Y = -10.000
 1 gram SAR value : 0.534 W/kg
 Area Scan Peak SAR : 0.655 W/kg
 Zoom Scan Peak SAR : 1.271 W/kg

Maxima Summary:
 Maxima #1
 Maxima coordinates: X = 0.140, Y = -10.000
 1 gram SAR value : 0.534 W/kg
 Area Scan Peak SAR : 0.655 W/kg
 Zoom Scan Peak SAR : 1.271 W/kg



Data No. 5:

Report Date : 27-Jun-2017
By Operator : 123
Measurement Date : 27-Jun-2017
Starting Time : 27-Jun-2017 11:11:03 AM
End Time : 27-Jun-2017 11:40:05 AM
Scanning Time : 1742 secs
Product Data
Device Name : 17LR138
Serial No. : NA
Type : Other
Model : DPB30
Frequency : 2450.00 MHz
Max. Transmit Pwr : 0.25 W
Drift Time : 1 min(s)
Length : 52 mm
Width : 95 mm
Depth : 27 mm
Antenna Type : Internal
Orientation : Touch
Power Drift-Start : 0.032 W/kg
Power Drift-Finish: 0.033 W/kg
Power Drift (%) : 4.073
Picture : C:\alsas\bitmap\Device-5.bmp

Phantom Data
Name : APREL-Uni
Type : Uni-Phantom
Size (mm) : 280 x 280 x 200
Serial No. : User Define
Location : Center
Description : Uni-Phantom

Tissue Data
Type : BODY
Serial No. : 2450B
Frequency : 2450.00 MHz
Last Calib. Date : 27-Jun-2017
Temperature : 21.50 °C
Ambient Temp. : 21.50 °C
Humidity : 62.00 RH%
Epsilon (Dielectric Constant): 54.51
Sigma : 1.93 S/m
Density : 1000.00 kg/cu. m



Probe Data

Name : E-field
Model : E-020
Type : E-Field Triangle
Serial No. : 266
Last Calib. Date : 16-Feb-2017
Frequency : 2450.00 MHz
Duty Cycle Factor (CreF) : 1
Conversion Factor : 5
Probe Sensitivity : 1.21 1.21 1.20 $\mu\text{V}/(\text{V}/\text{m})^2$
Compression Point : 95.00 mV
Offset : 1.56 mm

Measurement Data

Crest Factor : 1
Scan Type : Complete
Tissue Temp. : 21.50 °C
Ambient Temp. : 21.50 °C
Set-up Date : 27-Jun-2017
Set-up Time : 9:28:02 AM
Area Scan : 7x9x1 : Measurement x=10mm, y=10mm, z=4mm
Zoom Scan : 5x5x8 : Measurement x=8mm, y=8mm, z=4mm

Other Data

DUT Position : Touch
Separation : 0
Channel : High

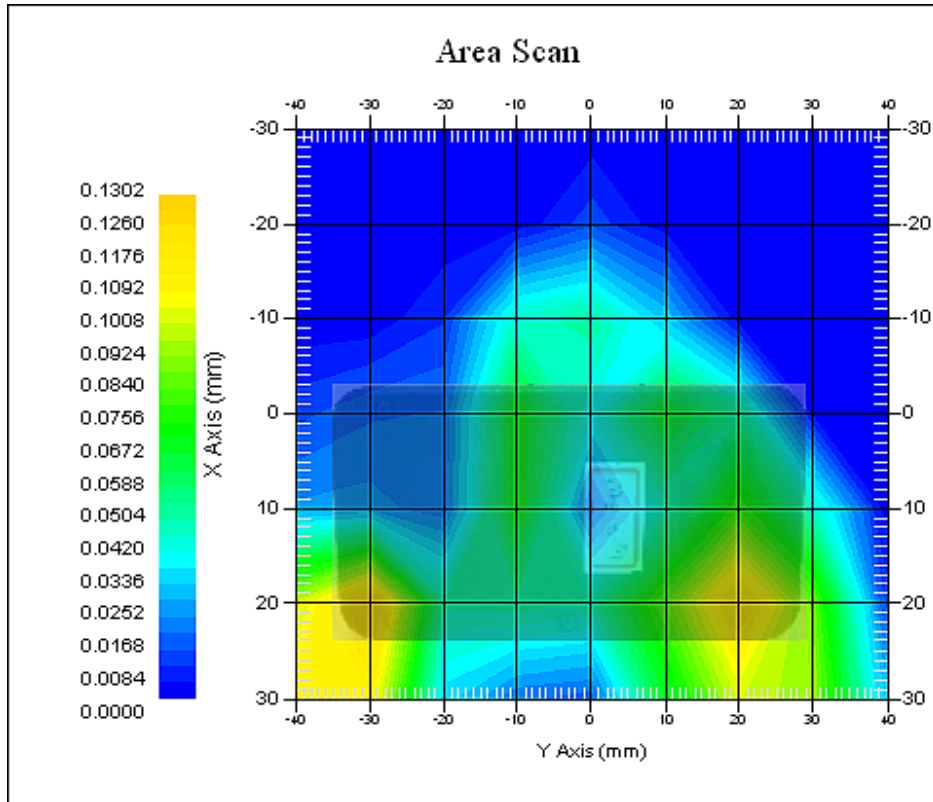

The system detected 2 maxima.
Selected highest maxima # = 1.
Maxima #1 coordinates: X = 20.110, Y = -30.000
1 gram SAR value : 0.108 W/kg
Area Scan Peak SAR : 0.129 W/kg
Zoom Scan Peak SAR : 0.270 W/kg

Maxima Summary:

Maxima #1
Maxima coordinates: X = 20.110, Y = -30.000
1 gram SAR value : 0.108 W/kg
Area Scan Peak SAR : 0.129 W/kg
Zoom Scan Peak SAR : 0.270 W/kg

Maxima #2
Maxima coordinates: X = 20.200, Y = 19.800
1 gram SAR value : 0.100 W/kg
Area Scan Peak SAR : 0.129 W/kg
Zoom Scan Peak SAR : 0.220 W/kg



Data No. 6:

Report Date : 27-Jun-2017
By Operator : 123
Measurement Date : 27-Jun-2017
Starting Time : 27-Jun-2017 03:52:14 PM
End Time : 27-Jun-2017 04:12:02 PM
Scanning Time : 1188 secs
Product Data
Device Name : 17LR138
Serial No. : NA
Type : Other
Model : DPB30
Frequency : 2450.00 MHz
Max. Transmit Pwr : 0.25 W
Drift Time : 1 min(s)
Length : 27 mm
Width : 95 mm
Depth : 52 mm
Antenna Type : Internal
Orientation : Touch
Power Drift-Start : 0.147 W/kg
Power Drift-Finish: 0.141 W/kg
Power Drift (%) : -3.990
Picture : C:\alsas\bitmap\Device-7.bmp

Phantom Data
Name : APREL-Uni
Type : Uni-Phantom
Size (mm) : 280 x 280 x 200
Serial No. : User Define
Location : Center
Description : Uni-Phantom

Tissue Data
Type : BODY
Serial No. : 2450B
Frequency : 2450.00 MHz
Last Calib. Date : 27-Jun-2017
Temperature : 21.50 °C
Ambient Temp. : 21.50 °C
Humidity : 62.00 RH%
Epsilon (Dielectric Constant): 54.51
Sigma : 1.93 S/m
Density : 1000.00 kg/cu. m



Probe Data

Name : E-field
Model : E-020
Type : E-Field Triangle
Serial No. : 266
Last Calib. Date : 16-Feb-2017
Frequency : 2450.00 MHz
Duty Cycle Factor (CreF) : 1
Conversion Factor : 5
Probe Sensitivity : 1.21 1.21 1.20 $\mu\text{V}/(\text{V}/\text{m})^2$
Compression Point : 95.00 mV
Offset : 1.56 mm

Measurement Data

Crest Factor : 1
Scan Type : Complete
Tissue Temp. : 21.50 °C
Ambient Temp. : 21.50 °C
Set-up Date : 27-Jun-2017
Set-up Time : 9:28:02 AM
Area Scan : 7x9x1 : Measurement x=10mm, y=10mm, z=4mm
Zoom Scan : 5x5x8 : Measurement x=8mm, y=8mm, z=4mm

Other Data

DUT Position : Touch
Separation : 0
Channel : High

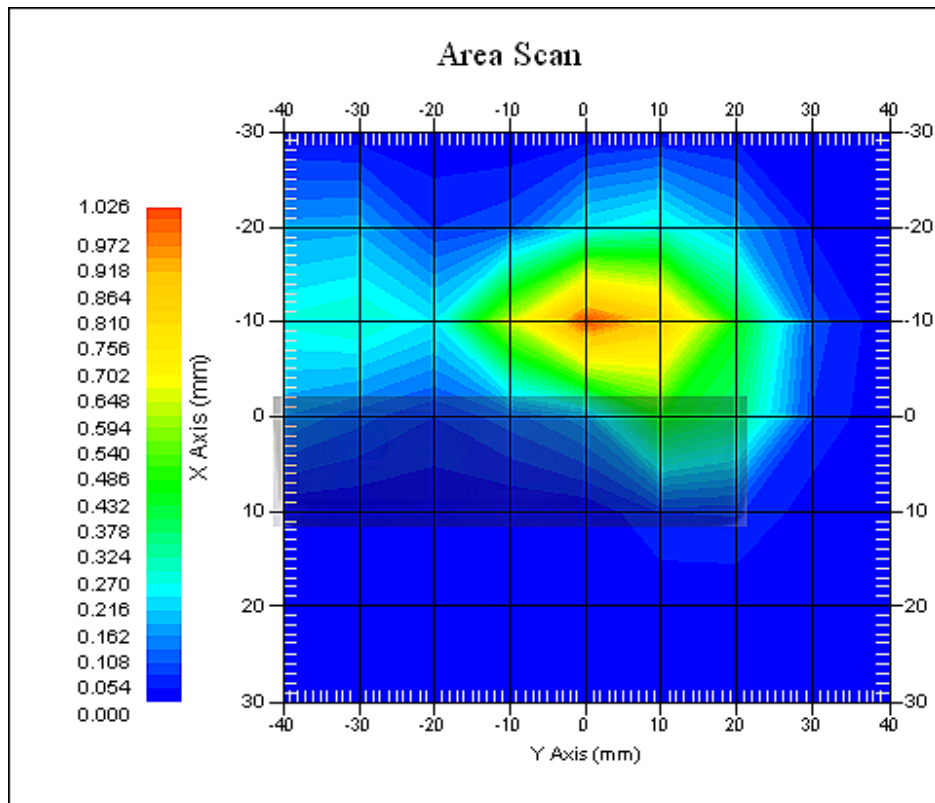

The system detected 1 maxima.
Selected highest maxima # = 1.
Maxima #1 coordinates: X = -9.870, Y = 0.000
1 gram SAR value : 0.776 W/kg
Area Scan Peak SAR : 1.025 W/kg
Zoom Scan Peak SAR : 2.091 W/kg

Maxima Summary:

Maxima #1
Maxima coordinates: X = -9.870, Y = 0.000
1 gram SAR value : 0.776 W/kg
Area Scan Peak SAR : 1.025 W/kg
Zoom Scan Peak SAR : 2.091 W/kg



Data No. 7:

Report Date : 27-Jun-2017
By Operator : 123
Measurement Date : 27-Jun-2017
Starting Time : 27-Jun-2017 01:54:24 PM
End Time : 27-Jun-2017 02:14:13 PM
Scanning Time : 1189 secs
Product Data
Device Name : 17LR138
Serial No. : NA
Type : Other
Model : DPB30
Frequency : 2450.00 MHz
Max. Transmit Pwr : 0.25 W
Drift Time : 1 min(s)
Length : 27 mm
Width : 95 mm
Depth : 52 mm
Antenna Type : Internal
Orientation : Touch
Power Drift-Start : 0.555 W/kg
Power Drift-Finish: 0.579 W/kg
Power Drift (%) : 4.496
Picture : C:\alsas\bitmap\Device-9.bmp

Phantom Data
Name : APREL-Uni
Type : Uni-Phantom
Size (mm) : 280 x 280 x 200
Serial No. : User Define
Location : Center
Description : Uni-Phantom

Tissue Data
Type : BODY
Serial No. : 2450B
Frequency : 2450.00 MHz
Last Calib. Date : 27-Jun-2017
Temperature : 21.50 °C
Ambient Temp. : 21.50 °C
Humidity : 62.00 RH%
Epsilon (Dielectric Constant): 54.51
Sigma : 1.93 S/m
Density : 1000.00 kg/cu. m



Probe Data

Name : E-field
Model : E-020
Type : E-Field Triangle
Serial No. : 266
Last Calib. Date : 16-Feb-2017
Frequency : 2450.00 MHz
Duty Cycle Factor (CreF) : 1
Conversion Factor : 5
Probe Sensitivity : 1.21 1.21 1.20 $\mu\text{V}/(\text{V}/\text{m})^2$
Compression Point : 95.00 mV
Offset : 1.56 mm

Measurement Data

Crest Factor : 1
Scan Type : Complete
Tissue Temp. : 21.50 °C
Ambient Temp. : 21.50 °C
Set-up Date : 27-Jun-2017
Set-up Time : 9:28:02 AM
Area Scan : 7x9x1 : Measurement x=10mm, y=10mm, z=4mm
Zoom Scan : 5x5x8 : Measurement x=8mm, y=8mm, z=4mm

Other Data

DUT Position : Touch
Separation : 0
Channel : Low

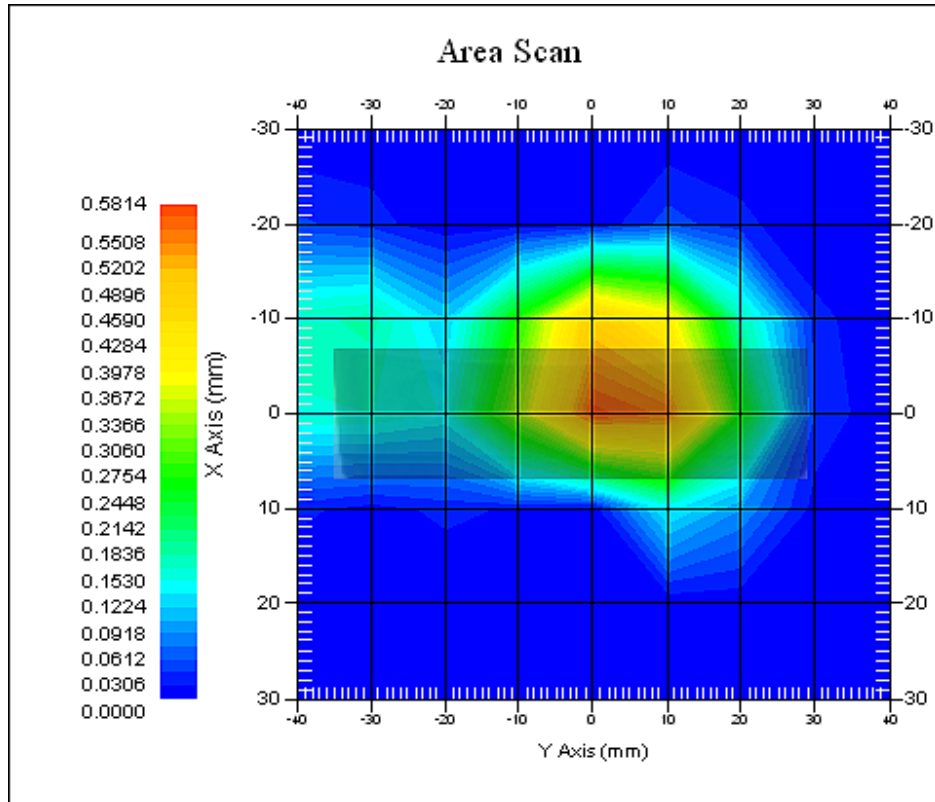

The system detected 1 maxima.
 Selected highest maxima # = 1.
 Maxima #1 coordinates: X = -7.950, Y = 0.000
 1 gram SAR value : 0.556 W/kg
 Area Scan Peak SAR : 0.572 W/kg
 Zoom Scan Peak SAR : 1.441 W/kg

Maxima Summary:

Maxima #1
 Maxima coordinates: X = -7.950, Y = 0.000
 1 gram SAR value : 0.556 W/kg
 Area Scan Peak SAR : 0.572 W/kg
 Zoom Scan Peak SAR : 1.441 W/kg



Data No. 8:

Report Date : 27-Jun-2017
By Operator : 123
Measurement Date : 27-Jun-2017
Starting Time : 27-Jun-2017 02:25:41 PM
End Time : 27-Jun-2017 02:45:41 PM
Scanning Time : 1200 secs
Product Data
Device Name : 17LR138
Serial No. : NA
Type : Other
Model : DPB30
Frequency : 2450.00 MHz
Max. Transmit Pwr : 0.25 W
Drift Time : 1 min(s)
Length : 27 mm
Width : 95 mm
Depth : 52 mm
Antenna Type : Internal
Orientation : Touch
Power Drift-Start : 0.279 W/kg
Power Drift-Finish: 0.292 W/kg
Power Drift (%) : 4.957
Picture : C:\alsas\bitmap\Device-9.bmp

Phantom Data
Name : APREL-Uni
Type : Uni-Phantom
Size (mm) : 280 x 280 x 200
Serial No. : User Define
Location : Center
Description : Uni-Phantom

Tissue Data
Type : BODY
Serial No. : 2450B
Frequency : 2450.00 MHz
Last Calib. Date : 27-Jun-2017
Temperature : 21.50 °C
Ambient Temp. : 21.50 °C
Humidity : 62.00 RH%
Epsilon (Dielectric Constant): 54.51
Sigma : 1.93 S/m
Density : 1000.00 kg/cu. m



Probe Data

Name : E-field
Model : E-020
Type : E-Field Triangle
Serial No. : 266
Last Calib. Date : 16-Feb-2017
Frequency : 2450.00 MHz
Duty Cycle Factor (CreF) : 1
Conversion Factor : 5
Probe Sensitivity : 1.21 1.21 1.20 $\mu\text{V}/(\text{V}/\text{m})^2$
Compression Point : 95.00 mV
Offset : 1.56 mm

Measurement Data

Crest Factor : 1
Scan Type : Complete
Tissue Temp. : 21.50 °C
Ambient Temp. : 21.50 °C
Set-up Date : 27-Jun-2017
Set-up Time : 9:28:02 AM
Area Scan : 7x9x1 : Measurement x=10mm, y=10mm, z=4mm
Zoom Scan : 5x5x8 : Measurement x=8mm, y=8mm, z=4mm

Other Data

DUT Position : Touch
Separation : 0
Channel : Mid

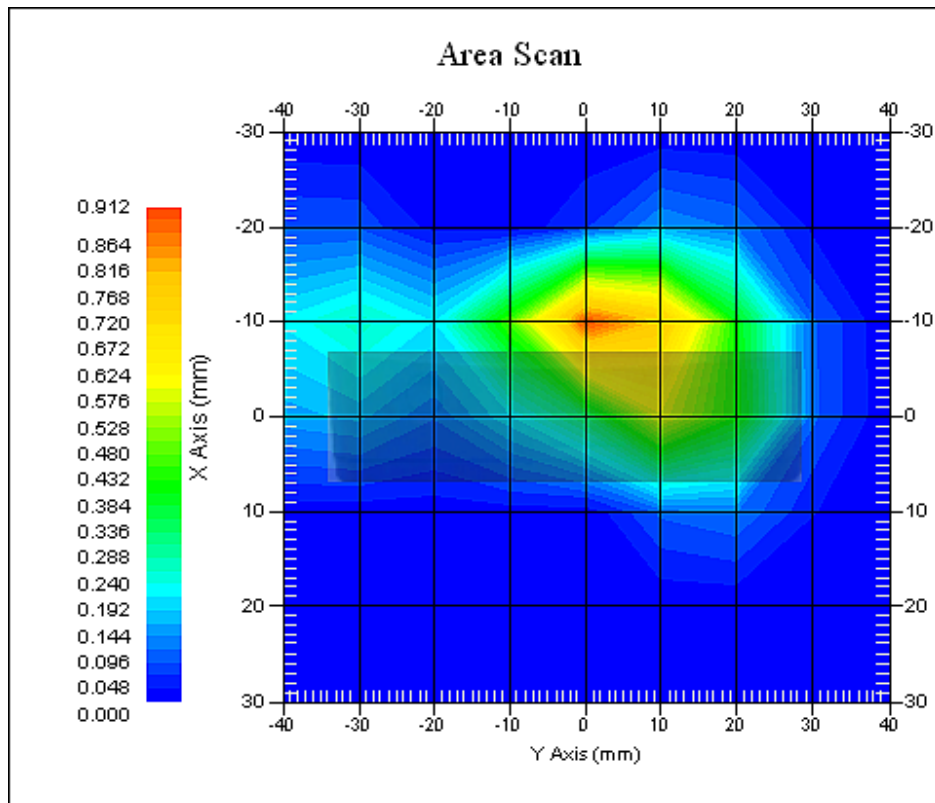

The system detected 1 maxima.
 Selected highest maxima # = 1.
 Maxima #1 coordinates: X = -9.880, Y = 0.000
 1 gram SAR value : 0.683 W/kg
 Area Scan Peak SAR : 0.910 W/kg
 Zoom Scan Peak SAR : 1.871 W/kg

Maxima Summary:

Maxima #1
 Maxima coordinates: X = -9.880, Y = 0.000
 1 gram SAR value : 0.683 W/kg
 Area Scan Peak SAR : 0.910 W/kg
 Zoom Scan Peak SAR : 1.871 W/kg



Data No. 9:

Report Date : 27-Jun-2017
By Operator : 123
Measurement Date : 27-Jun-2017
Starting Time : 27-Jun-2017 04:52:11 PM
End Time : 27-Jun-2017 05:11:53 PM
Scanning Time : 1182 secs
Product Data
Device Name : 17LR138
Serial No. : NA
Type : Other
Model : DPB30
Frequency : 2450.00 MHz
Max. Transmit Pwr : 0.25 W
Drift Time : 1 min(s)
Length : 27 mm
Width : 95 mm
Depth : 52 mm
Antenna Type : Internal
Orientation : Touch
Power Drift-Start : 0.188 W/kg
Power Drift-Finish: 0.195 W/kg
Power Drift (%) : 4.199
Picture : C:\alsas\bitmap\Device-7.bmp

Phantom Data
Name : APREL-Uni
Type : Uni-Phantom
Size (mm) : 280 x 280 x 200
Serial No. : User Define
Location : Center
Description : Uni-Phantom

Tissue Data
Type : BODY
Serial No. : 2450B
Frequency : 2450.00 MHz
Last Calib. Date : 27-Jun-2017
Temperature : 21.50 °C
Ambient Temp. : 21.50 °C
Humidity : 62.00 RH%
Epsilon (Dielectric Constant): 54.51
Sigma : 1.93 S/m
Density : 1000.00 kg/cu. m



Probe Data

Name : E-field
Model : E-020
Type : E-Field Triangle
Serial No. : 266
Last Calib. Date : 16-Feb-2017
Frequency : 2450.00 MHz
Duty Cycle Factor (CreF): 1
Conversion Factor : 5
Probe Sensitivity : 1.21 1.21 1.20 $\mu\text{V}/(\text{V}/\text{m})^2$
Compression Point : 95.00 mV
Offset : 1.56 mm

Measurement Data

Crest Factor : 1
Scan Type : Complete
Tissue Temp. : 21.50 °C
Ambient Temp. : 21.50 °C
Set-up Date : 27-Jun-2017
Set-up Time : 9:28:02 AM
Area Scan : 7x9x1 : Measurement x=10mm, y=10mm, z=4mm
Zoom Scan : 5x5x8 : Measurement x=8mm, y=8mm, z=4mm

Other Data

DUT Position : Touch
Separation : 0
Channel : High

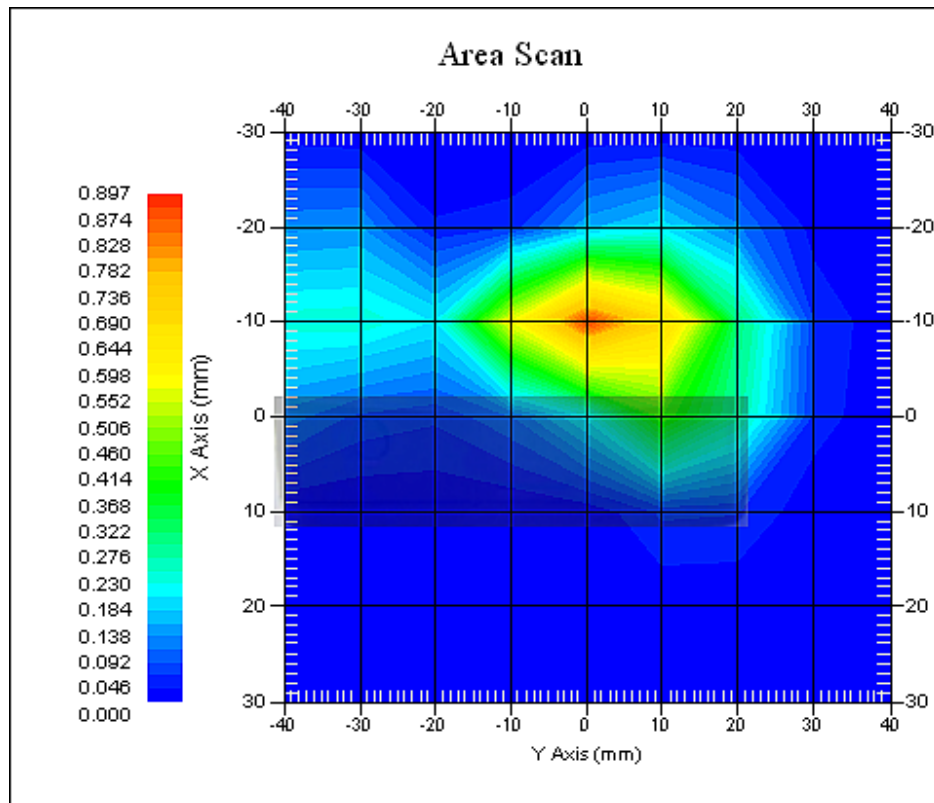

The system detected 1 maxima.
Selected highest maxima # = 1.
Maxima #1 coordinates: X = -9.940, Y = 0.000
1 gram SAR value : 0.686 W/kg
Area Scan Peak SAR : 0.880 W/kg
Zoom Scan Peak SAR : 1.871 W/kg

Maxima Summary:

Maxima #1
Maxima coordinates: X = -9.940, Y = 0.000
1 gram SAR value : 0.686 W/kg
Area Scan Peak SAR : 0.880 W/kg
Zoom Scan Peak SAR : 1.871 W/kg



Data No. 10:

Report Date : 27-Jun-2017
By Operator : 123
Measurement Date : 27-Jun-2017
Starting Time : 27-Jun-2017 04:34:37 PM
End Time : 27-Jun-2017 04:54:43 PM
Scanning Time : 1206 secs
Product Data
Device Name : 17LR138
Serial No. : NA
Type : Other
Model : DPB30
Frequency : 2450.00 MHz
Max. Transmit Pwr : 0.25 W
Drift Time : 1 min(s)
Length : 27 mm
Width : 95 mm
Depth : 52 mm
Antenna Type : Internal
Orientation : Touch
Power Drift-Start : 0.001 W/kg
Power Drift-Finish: 0.000 W/kg
Power Drift (%) : 0.000
Picture : C:\alsas\bitmap\Device-7.bmp

Phantom Data
Name : APREL-Uni
Type : Uni-Phantom
Size (mm) : 280 x 280 x 200
Serial No. : User Define
Location : Center
Description : Uni-Phantom

Tissue Data
Type : BODY
Serial No. : 2450B
Frequency : 2450.00 MHz
Last Calib. Date : 27-Jun-2017
Temperature : 21.50 °C
Ambient Temp. : 21.50 °C
Humidity : 62.00 RH%
Epsilon (Dielectric Constant): 54.51
Sigma : 1.93 S/m
Density : 1000.00 kg/cu. m



Probe Data

Name : E-field
Model : E-020
Type : E-Field Triangle
Serial No. : 266
Last Calib. Date : 16-Feb-2017
Frequency : 2450.00 MHz
Duty Cycle Factor (CreF) : 1
Conversion Factor : 5
Probe Sensitivity : 1.21 1.21 1.20 $\mu\text{V}/(\text{V}/\text{m})^2$
Compression Point : 95.00 mV
Offset : 1.56 mm

Measurement Data

Crest Factor : 1
Scan Type : Complete
Tissue Temp. : 21.50 °C
Ambient Temp. : 21.50 °C
Set-up Date : 27-Jun-2017
Set-up Time : 9:28:02 AM
Area Scan : 7x9x1 : Measurement x=10mm, y=10mm, z=4mm
Zoom Scan : 5x5x8 : Measurement x=8mm, y=8mm, z=4mm

Other Data

DUT Position : Touch
Separation : 0
Channel : Mid

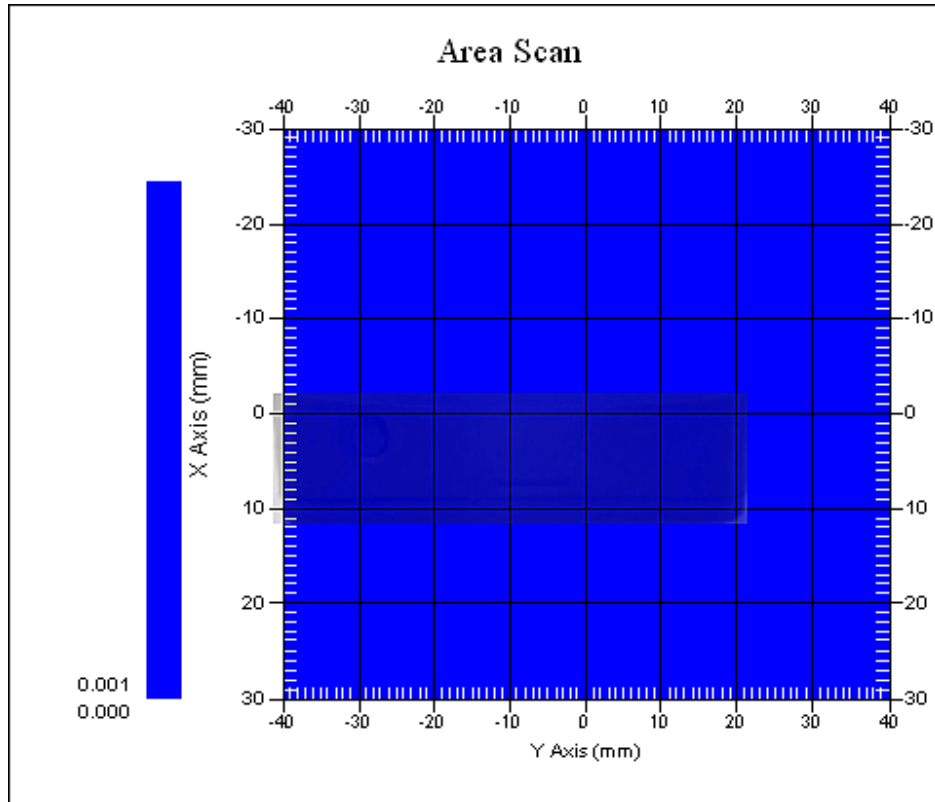

The system detected 1 maxima.
Selected highest maxima # = 1.
Maxima #1 coordinates: X = 13.120, Y = 22.900
1 gram SAR value : 0.001 W/kg
Area Scan Peak SAR : 0.001 W/kg
Zoom Scan Peak SAR : 0.000 W/kg

Maxima Summary:
Maxima #1
Maxima coordinates: X = 13.120, Y = 22.900
1 gram SAR value : 0.001 W/kg
Area Scan Peak SAR : 0.001 W/kg
Zoom Scan Peak SAR : 0.000 W/kg



Data No.11:

Report Date : 27-Jun-2017
By Operator : 123
Measurement Date : 27-Jun-2017
Starting Time : 27-Jun-2017 04:56:04 PM
End Time : 27-Jun-2017 05:15:56 PM
Scanning Time : 1192 secs
Product Data
Device Name : 17LR138
Serial No. : NA
Type : Other
Model : DPB30
Frequency : 2450.00 MHz
Max. Transmit Pwr : 0.25 W
Drift Time : 1 min(s)
Length : 27 mm
Width : 95 mm
Depth : 52 mm
Antenna Type : Internal
Orientation : Touch
Power Drift-Start : 0.001 W/kg
Power Drift-Finish: 0.000 W/kg
Power Drift (%) : 0.000
Picture : C:\alsas\bitmap\Device-7.bmp

Phantom Data
Name : APREL-Uni
Type : Uni-Phantom
Size (mm) : 280 x 280 x 200
Serial No. : User Define
Location : Center
Description : Uni-Phantom

Tissue Data
Type : BODY
Serial No. : 2450B
Frequency : 2450.00 MHz
Last Calib. Date : 27-Jun-2017
Temperature : 21.50 °C
Ambient Temp. : 21.50 °C
Humidity : 62.00 RH%
Epsilon (Dielectric Constant): 54.51
Sigma : 1.93 S/m
Density : 1000.00 kg/cu. m



Probe Data

Name : E-field
Model : E-020
Type : E-Field Triangle
Serial No. : 266
Last Calib. Date : 16-Feb-2017
Frequency : 2450.00 MHz
Duty Cycle Factor (CreF): 1
Conversion Factor : 5
Probe Sensitivity : 1.21 1.21 1.20 $\mu\text{V}/(\text{V}/\text{m})^2$
Compression Point : 95.00 mV
Offset : 1.56 mm

Measurement Data

Crest Factor : 1
Scan Type : Complete
Tissue Temp. : 21.50 °C
Ambient Temp. : 21.50 °C
Set-up Date : 09-Jun-2017
Set-up Time : 9:28:02 AM
Area Scan : 7x9x1 : Measurement x=10mm, y=10mm, z=4mm
Zoom Scan : 5x5x8 : Measurement x=8mm, y=8mm, z=4mm

Other Data

DUT Position : Touch
Separation : 0
Channel : Mid

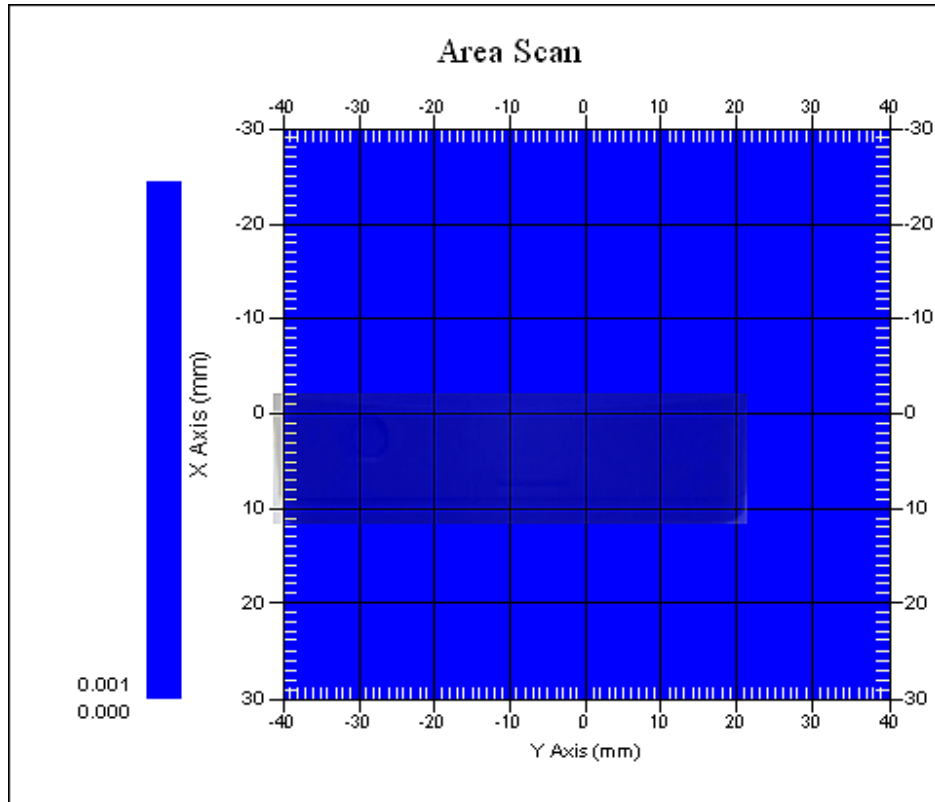

The system detected 1 maxima.
Selected highest maxima # = 1.
Maxima #1 coordinates: X = 13.110, Y = 22.900
1 gram SAR value : 0.001 W/kg
Area Scan Peak SAR : 0.001 W/kg
Zoom Scan Peak SAR : 0.000 W/kg

Maxima Summary:
Maxima #1
Maxima coordinates: X = 13.110, Y = 22.900
1 gram SAR value : 0.001 W/kg
Area Scan Peak SAR : 0.001 W/kg
Zoom Scan Peak SAR : 0.000 W/kg

SAR-Z Axis at Hotspot x:-9.87 y:-0.06

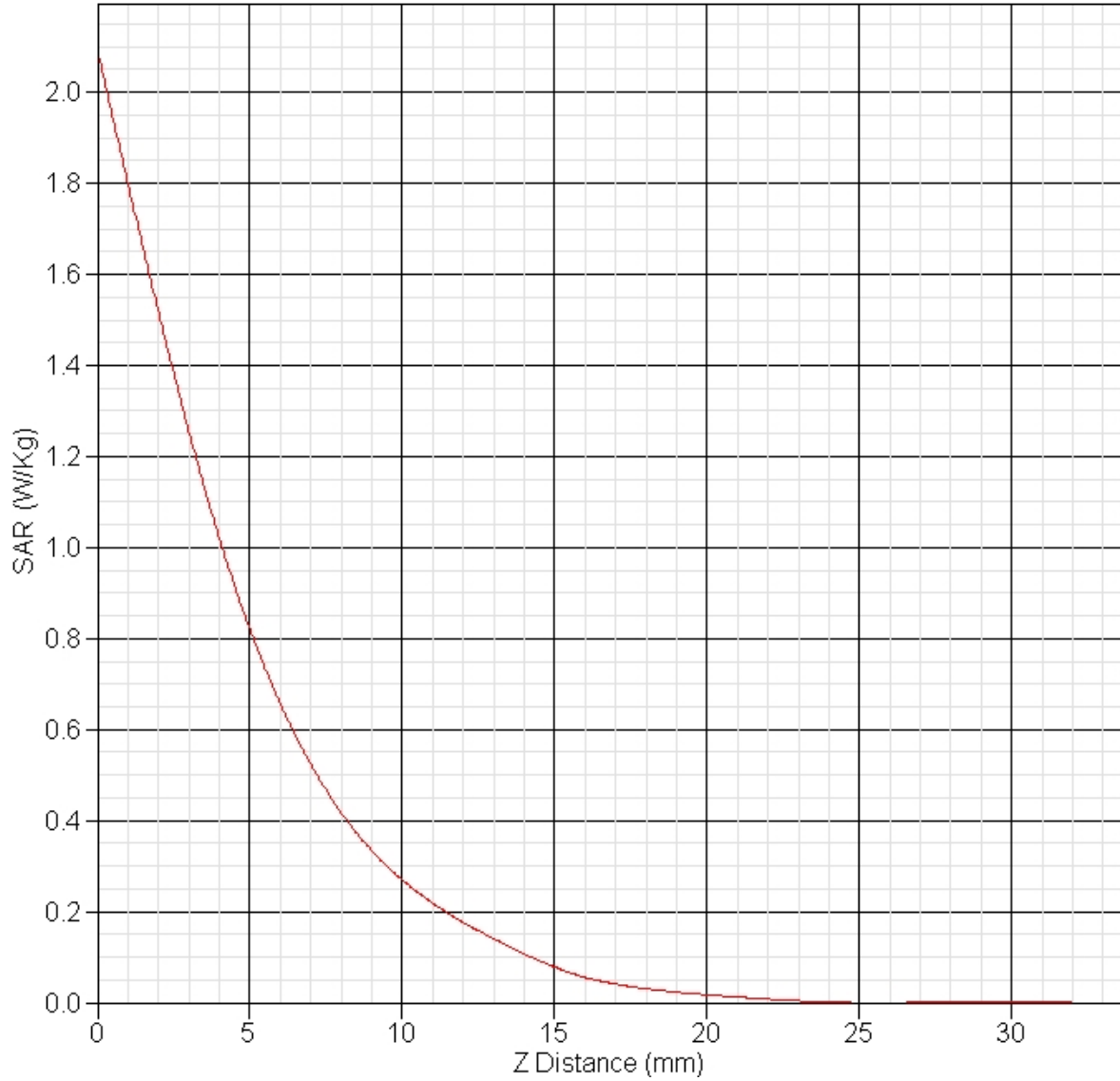

NCL CALIBRATION LABORATORIES

Calibration File No.: PC-1720

Task No: 5833

Client.: International Standards Laboratory

Address: No. 120, Lane 180, Hsin Ho Rd.,

Lung-Tan Dist., Tao Yuan City 325, Taiwan

CERTIFICATE OF CALIBRATION

It is certified that the equipment identified below has been calibrated in the
NCL CALIBRATION LABORATORIES by qualified personnel following recognized
procedures and using transfer standards traceable to NRC/NIST.

Equipment: Miniature Isotropic RF Probe

Record of Calibration

Body

Manufacturer: APREL Inc.

Model No.: ALS-E020

Serial No.: 266

Calibration Procedure:

D01-032-E020-V2,

D22-012-Tissue,

D28-002-Dipole

Calibrated: 16th February 2017

Released on: 17th February 2017

This Calibration Certificate is Incomplete Unless Accompanied with the Calibration Results Summary

Released By: _____



Art Brennan, Quality Manager

NCL CALIBRATION LABORATORIES

Suite 102, 303 Terry Fox Dr,
OTTAWA, ONTARIO
CANADA K2K 3J1

Division of APREL Lab.
TEL: (613) 435-8300
FAX: (613) 435-8306

Introduction

This Calibration Report reproduces the results of the calibration performed in line with the references listed below. Calibration is performed using accepted methodologies as per the references listed below. Probes are calibrated for air, and tissue and the values reported are the results from the physical quantification.

Calibration Method

Probes are calibrated using the following methods.

<800 MHz

TEM Cell for sensitivity in air

Standard phantom using temperature transfer method for sensitivity in tissue

>800 MHz

Waveguide* method to determine sensitivity in air and tissue

*Waveguide is numerically (simulation) assessed to determine the field distribution and power

The boundary effect for the probe is assessed using a standard flat phantom where the probe output is compared against a numerically simulated series of data points

References

- IEEE Standard 1528:2013
IEEE Recommended Practice for Determining the Peak Spatial-Average Specific Absorption Rate (SAR) in the Human Head from Wireless Communications Devices: Measurement Techniques
- IEC 62209-1:2006
Human Exposure to RF Fields from hand-held and body-mounted wireless communication devices - Human models, instrumentation, and procedures - Part 1: Procedure to measure the Specific Absorption Rate (SAR) for hand-held mobile wireless devices
- IEC 62209-2:2010
Human exposure to RF fields from hand-held and body-mounted wireless devices - Human models, instrumentation, and procedures - Part 2: specific absorption rate (SAR) for wireless communication devices (30 MHz - 6 GHz)
- TP-D01-032-E020-V2 E-Field probe calibration procedure
- D22-012-Tissue dielectric tissue calibration procedure
- D28-002-Dipole procedure for validation of SAR system using a dipole
- IEEE 1309 Standard for Calibration of Electromagnetic Field Sensors and Probes, Excluding Antennas, from 9kHz to 40GHz

NCL Calibration Laboratories

Division of APREL Inc.

DC-1720

Conditions

Probe 266 was a recalibration.

Ambient Temperature of the Laboratory: 20 °C +/- 1.5°C
Temperature of the Tissue: 21 °C +/- 1.5°C
Relative Humidity: < 60%

Primary Measurement Standards

Instrument	Serial Number	Cal due date
Power Meter Tektronix USB	11C940	Apr 2, 2017
Signal Generator Agilent E4438C	MY45094463	Dec 11, 2017

Secondary Measurement Standards

Network Analyzer Anritsu 37347C	002106	Jan. 26, 2019
---------------------------------	--------	---------------

Attestation

The below named signatories have conducted the calibration and review of the data which is presented in this calibration report.

We the undersigned attest that to the best of our knowledge the calibration of this subject has been accurately conducted and that all information contained within the results pages have been reviewed for accuracy.



Art Brennan, Quality Manager



Maryna Nesterova Calibration Engineer

Probe Summary

Probe Type: E-Field Probe E-020
Serial Number: 266
Frequency: As presented on page 5
Sensor Offset: 1.56
Sensor Length: 2.5
Tip Enclosure: Composite*
Tip Diameter: < 2.9 mm
Tip Length: 55 mm
Total Length: 289 mm
Diode Compression Point: 95 mV

Sensitivity in Air

Frequency Range	Channel X, $\mu\text{V}/(\text{V}/\text{m})^2$	Channel Y, $\mu\text{V}/(\text{V}/\text{m})^2$	Channel Z, $\mu\text{V}/(\text{V}/\text{m})^2$	Tolerance, $\mu\text{V}/(\text{V}/\text{m})^2$
700 MHz - 900 MHz	1.210	1.212	1.208	± 0.004
1 GHz – 4 GHz	1.207	1.210	1.202	± 0.004
5 GHz – 6 GHz	1.191	1.189	1.192	± 0.005

*Resistive to recommended tissue recipes per IEEE-1528

Calibration for Tissue (Head H, Body B)

Frequency, MHz	Tissue Type	Measured Epsilon	Measured Sigma	Standard Uncertainty (%)	Calibration Frequency Range (MHz)	Conversion Factor
450 H	Head	X	X	X	X	X
450 B	Body	X	X	X	X	X
700 H	Head	X	X	X	X	X
700 B	Body	55.85	0.95	3.5	±50	6.6
835 H	Head	X	X	X	X	X
835 B	Body	54.55	1.00	3.5	±50	6.8
900 H	Head	X	X	X	X	X
900 B	Body	55.16	1.06	3.5	±50	6.7
1450 H	Head	X	X	X	X	X
1450 B	Body	X	X	X	X	X
1500 H	Head	X	X	X	X	X
1500 B	Body	X	X	X	X	X
1640 H	Head	X	X	X	X	X
1640 B	Body	X	X	X	X	X
1750 H	Head					
1750 B	Body	53.55	1.48	3.5	±75	5.6
1800 H	Head	X	X	X	X	X
1800 B	Body	X	X	X	X	X
1900 H	Head	X	X	X	X	X
1900 B	Body	53.55	1.59	3.5	±75	5.4
2000 H	Head	X	X	X	X	X
2000 B	Body	53.15	1.57	3.5	±75	5.2
2100 H	Head	X	X	X	X	X
2100 B	Body	X	X	X	X	X
2300 H	Head	X	X	X	X	X
2300 B	Body	X	X	X	X	X
2450 H	Head	X	X	X	X	X
2450 B	Body	53.65	1.96	3.5	±75	5.0
2590 H	Head	X	X	X	X	X
2590 B	Body	53.52	2.19	3.5	±75X	4.9
3600 H	Head	X	X	X	X	X
3600 B	Body	X	X	X	X	X
5250 H	Head	X	X	X	X	X
5250 B	Body	47.54	5.23	3.5	±100	3.2
5600 H	Head	X	X	X	X	X
5600 B	Body	46.49	5.73	3.5	±100	2.8
5800 H	Head	X	X	X	X	X
5800 B	Body	45.99	6.10	3.5	±100	3.1

Boundary Effect:

Uncertainty resulting from the boundary effect is less than 2.1% for the distance between the tip of the probe and the tissue boundary, when less than 0.58mm.

Spatial Resolution:

The spatial resolution uncertainty is less than 1.5% for 4.9mm diameter probe.
 The spatial resolution uncertainty is less than 1.0% for 2.5mm diameter probe.

DAQ-PAQ Contribution

To minimize the uncertainty calculation all tissue sensitivity values were calculated using a load impedance of 5 MΩ.

Probe Calibration Uncertainty

Uncertainty component	Tolerance (± %)	Probability distribution	Divisor	Standard uncertainty (± %)
Incident or forward power	2.5	R	√3	1.44
Reflected power	2	R	√3	1.15
Liquid conductivity measurement	1	R	√3	0.58
Liquid permittivity measurement	1	R	√3	0.58
Liquid conductivity deviation	1.5	R	√3	0.87
Liquid permittivity deviation	1.5	R	√3	0.87
Frequency deviation	2.25	R	√3	1.30
Field homogeneity	2.5	R	√3	1.44
Field-probe positioning	2.5	R	√3	1.44
Field-probe linearity	1.55	R	√3	0.89
Combined standard uncertainty		RSS		3.50

Receiving Pattern Air

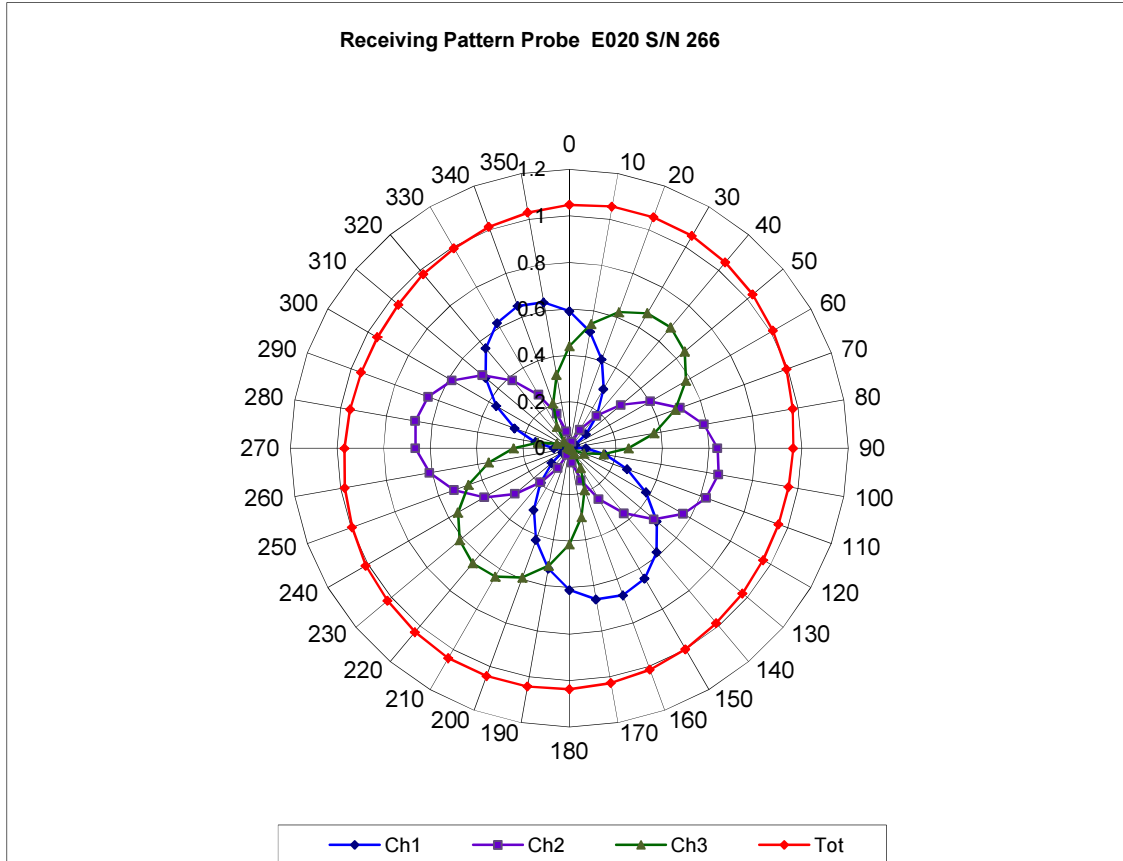

Isotropy Error Air

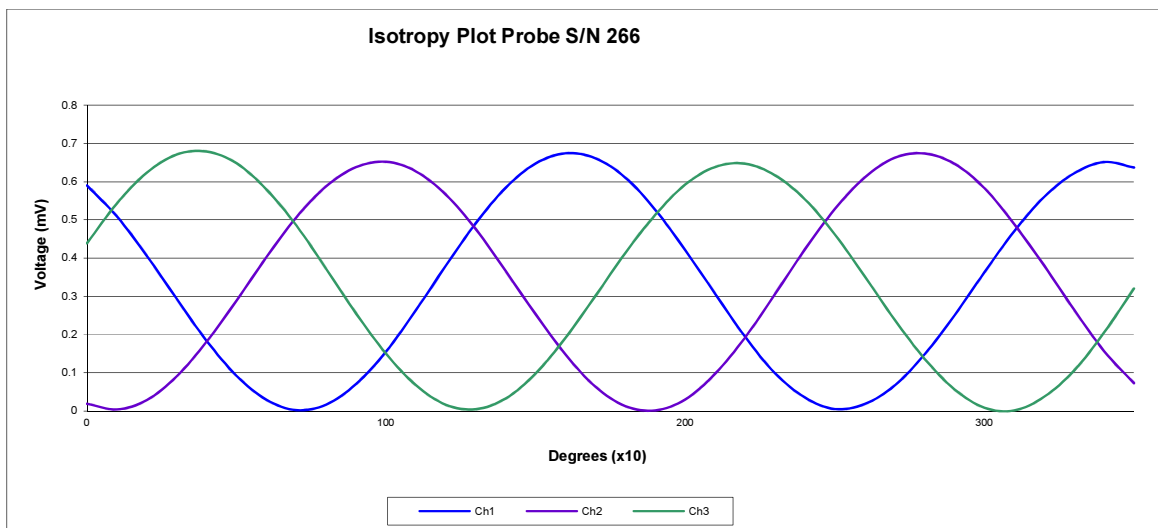
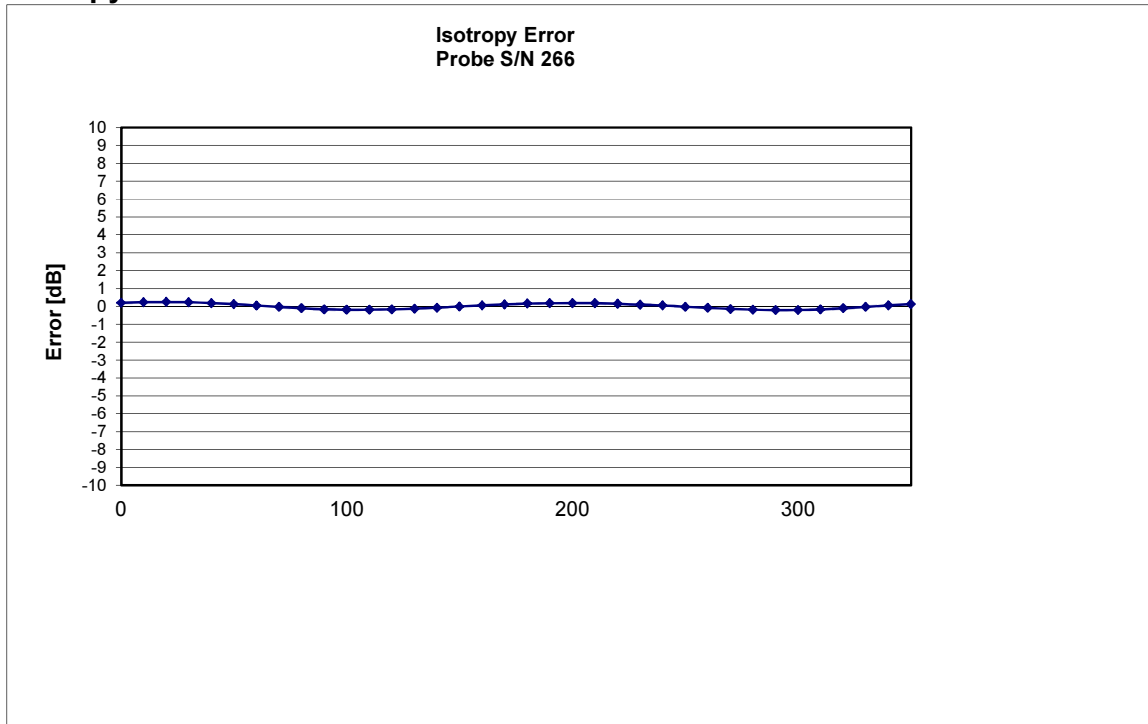

Dynamic Range

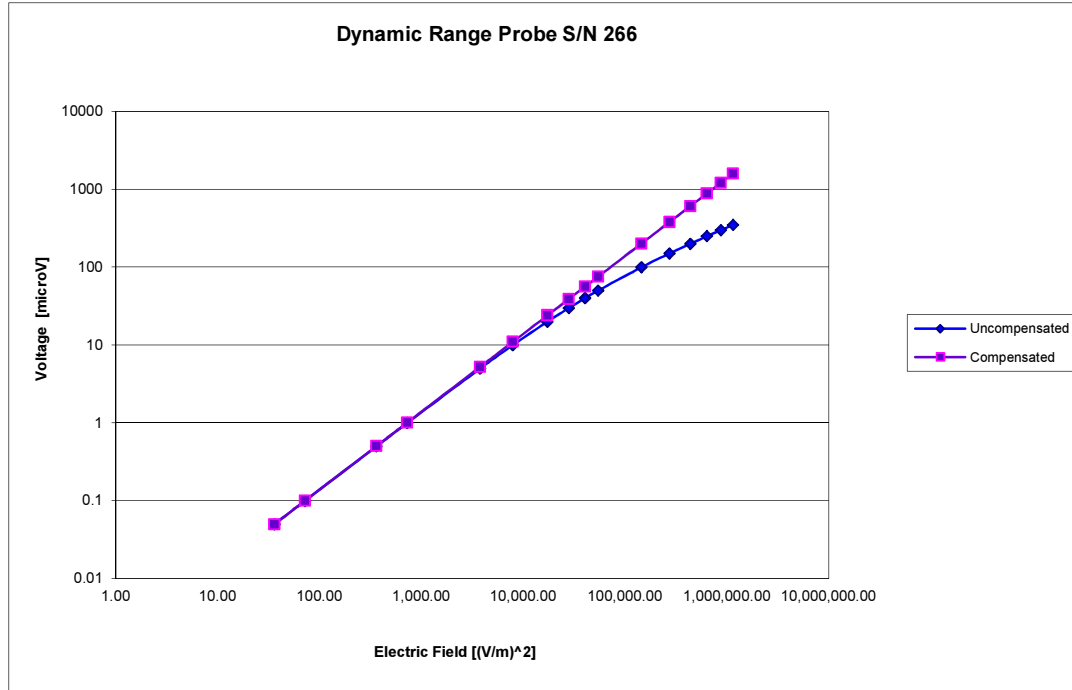

Video Bandwidth

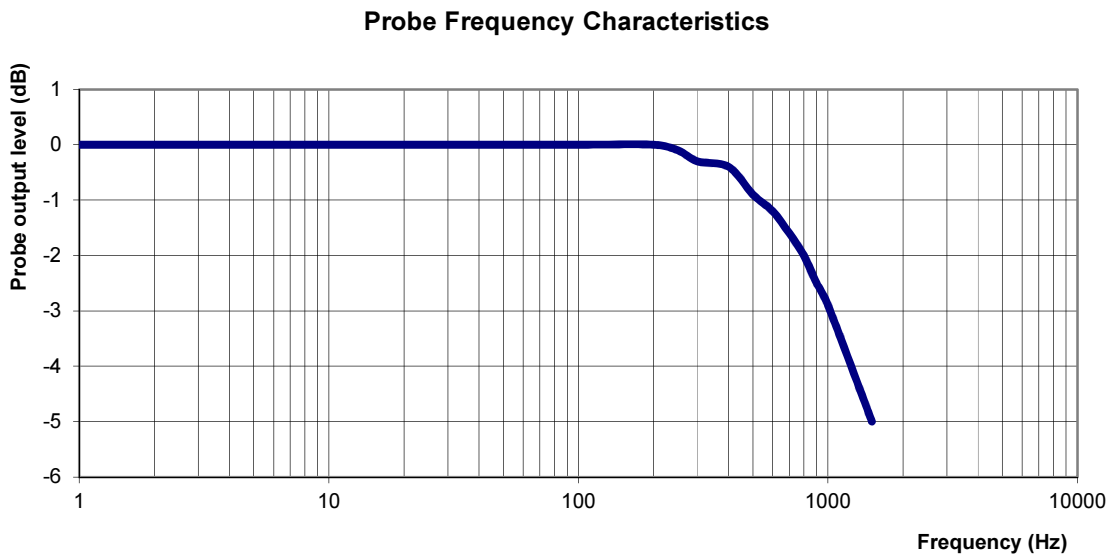

Video Bandwidth at 500 Hz 1 dB
 Video Bandwidth at 1.02 KHz: 3 dB

NCL CALIBRATION LABORATORIES

Calibration File No: DC-1613
Project Number: ISL-D-cal-5785

CERTIFICATE OF CALIBRATION

It is certified that the equipment identified below has been calibrated in the
NCL CALIBRATION LABORATORIES by qualified personnel following recognized
procedures and using transfer standards traceable to NRC/NIST.

Validation Dipole (Body)

Manufacturer: APREL Laboratories

Part number: ALS-D-2450-S-2

Frequency: 2450 MHz

Serial No: 220-00753

Customer: ISL

Calibrated: 12th January 2015
Released on: 15th January 2015

This Calibration Certificate is Incomplete Unless Accompanied with the Calibration Results Summary

Released By:



Art Brennan, Quality Manager

NCL CALIBRATION LABORATORIES

Suite 102, 303 Terry Fox Dr.
Kanata, ONTARIO
CANADA K2K 3J1

Division of APREL Lab.
TEL: (613) 435-8300
FAX: (613)435-8306

NCL Calibration Laboratories

Division of APREL Laboratories.

Conditions

Dipole 220-00753 was a re-calibration.

Ambient Temperature of the Laboratory: 22 °C +/- 0.5°C
Temperature of the Tissue: 21 °C +/- 0.5°C

Attestation

The below named signatories have conducted the calibration and review of the data which is presented in this calibration report.

We the undersigned attest that to the best of our knowledge the calibration of this subject has been accurately conducted and that all information contained within the results pages have been reviewed for accuracy.



Art Brennan, Quality Manager



Maryna Nesterova Calibration Engineer

Primary Measurement Standards

Instrument	Serial Number	Cal due date
Tektronix USB Power Meter	11C940	May 14, 2015
Network Analyzer Anritsu 37347C	002106	Feb. 20, 2015
Agilent Signal Generator	MY45094463	Dec. 2015

This page has been reviewed for content and attested to by signature within this document.

Calibration Results Summary

The following results relate the Calibrated Dipole and should be used as a quick reference for the user.

Mechanical Dimensions

Length	Height
51.5 mm	30.4 mm

Tissue Validation

Tissue	Frequency	Dielectric constant, ϵ_r	Conductivity, σ [S/m]
Body	2450 MHz	53.26	1.96

Electrical Specification

Tissue	Frequency	SWR:	Return Loss	Impedance
Body	2450 MHz	1.03 U	-36.635 dB	49.353 Ω

System Validation Results

Tissue	Frequency	1 Gram	10 Gram
Body	2450 MHz	53.46	24.89

Body

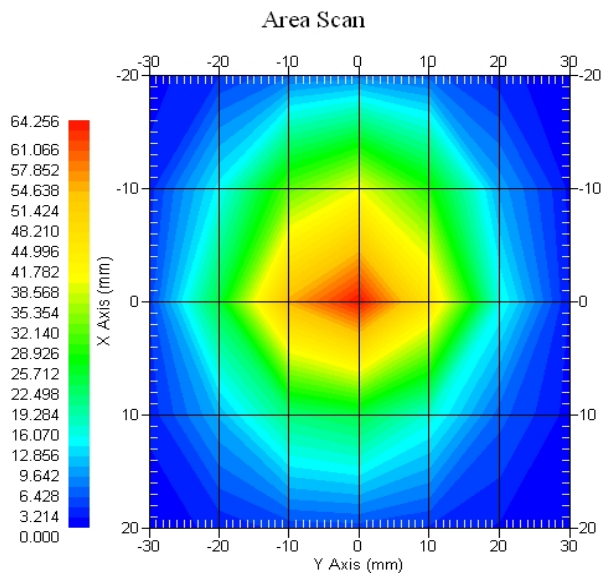

Introduction

This Calibration Report has been produced in line with the SSI Dipole Calibration Procedure SSI-TP-018-ALSAS. The results contained within this report are for Validation Dipole 220-00753. The calibration routine consisted of a three-step process. Step 1 was a mechanical verification of the dipole to ensure that it meets the mechanical specifications. Step 2 was an Electrical Calibration for the Validation Dipole, where the SWR, Impedance, and the Return loss were assessed. Step 3 involved a System Validation using the ALSAS-10U, along with APREL E-020 30 MHz to 6 GHz E-Field Probe Serial Number 266.

References

- IEEE Standard 1528:2013
IEEE Recommended Practice for Determining the Peak Spatial-Average Specific Absorption Rate (SAR) in the Human Head from Wireless Communications Devices: Measurement Techniques
- EN 62209-1:2006
Human Exposure to RF Fields from hand-held and body-mounted wireless communication devices - Human models, instrumentation, and procedures - Part 1: Procedure to measure the Specific Absorption Rate (SAR) for hand-held mobile wireless devices
- IEC 62209-2:2010
Human exposure to RF fields from hand-held and body-mounted wireless devices - Human models, instrumentation, and procedures - Part 2: specific absorption rate (SAR) for wireless communication devices (30 MHz - 6 GHz)
- D22-012-Tissue dielectric tissue calibration procedure
- D28-002-Dipole procedure for validation of SAR system using a dipole
- IEEE 1309 Standard for Calibration of Electromagnetic Field Sensors and Probes, Excluding Antennas, from 9kHz to 40GHz

Conditions

Ambient Temperature of the Laboratory: 21 °C +/- 0.5°C

Temperature of the Tissue: 21 °C +/- 0.5°C

Dipole Calibration uncertainty

The calibration uncertainty for the dipole is made up of various parameters presented below.

Mechanical	1%
Positioning Error	1.22%
Electrical	1.7%
Tissue	2.2%
Dipole Validation	2.2%
Combined Standard Uncertainty	3.88% (7.76% K=2)

The Following Graphs are the results as displayed on the Vector Network Analyzer.

S11 Parameter Return Loss

Body Tissue: Frequency Range 2386.9 MHz to 2513.4 MHz

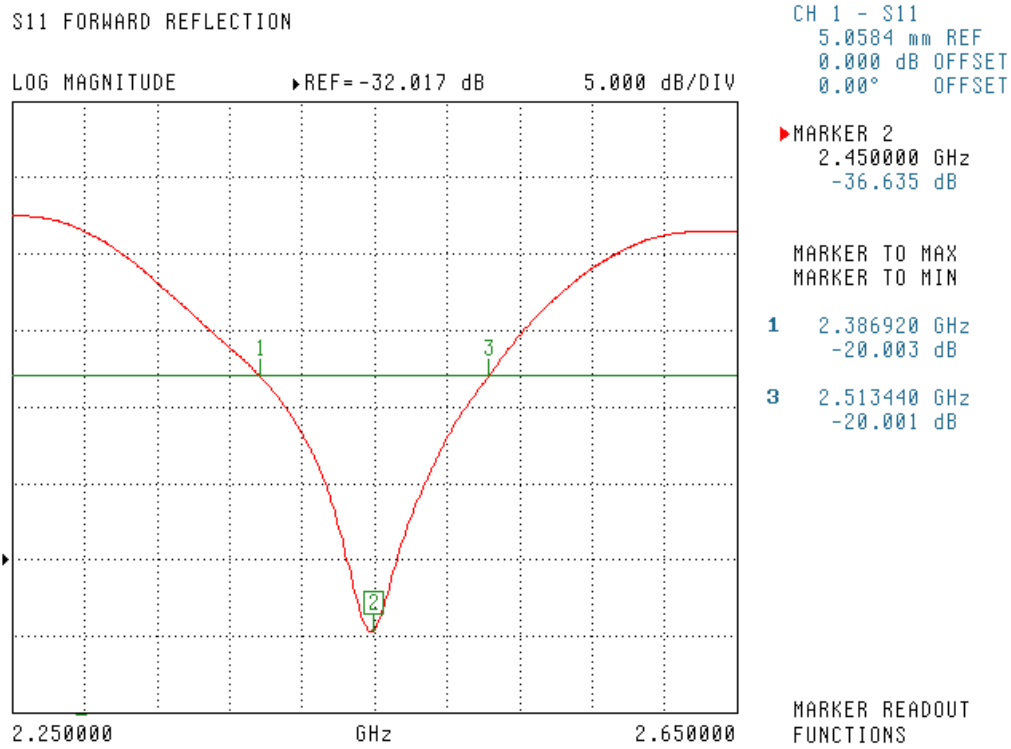

SWR

Body

S11 FORWARD REFLECTION

SWR ▶REF=913.800 mU 200.000 mU/DIV

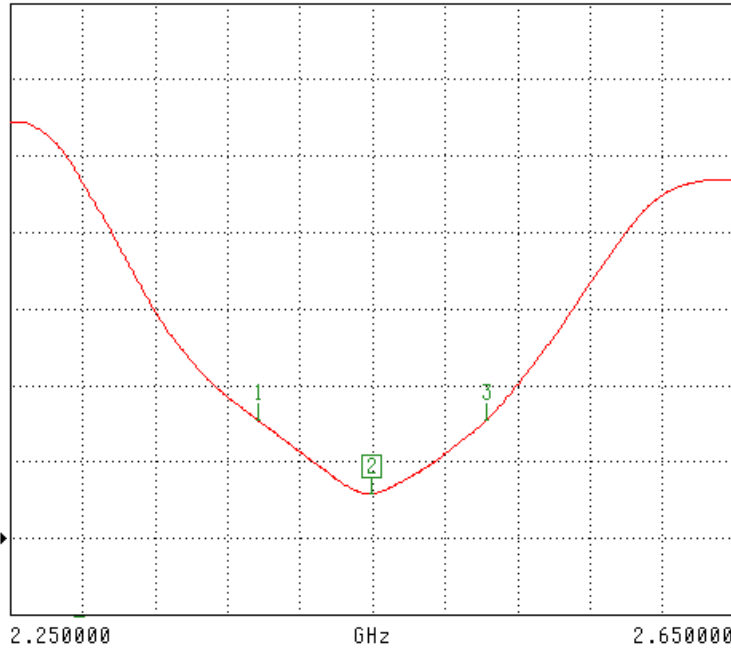

CH 1 - S11
5.0584 mm REF
0.000 dB OFFSET
0.00° OFFSET

▶ MARKER 2
2.450000 GHz
1.030 U

MARKER TO MAX
MARKER TO MIN

1 2.386920 GHz
1.223 U

3 2.513440 GHz
1.223 U

MARKER READOUT
FUNCTIONS

Smith Chart Dipole Impedance

Body

S11 FORWARD REFLECTION
IMPEDANCE

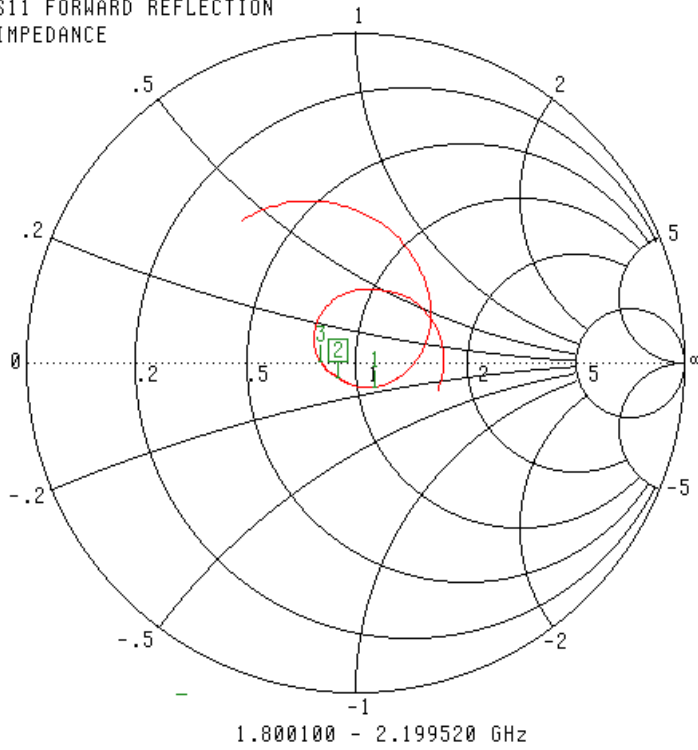

CH 1 - S11
5.0584 mm REF
0.000 dB OFFSET
0.00° OFFSET

▶ MARKER 2
2.000000 GHz
45.008 Ω
-4.246 jΩ

MARKER TO MAX
MARKER TO MIN

1 1.954662 GHz
55.879 Ω
-8.859 jΩ
3 2.026950 GHz
40.917 Ω
-157.369 jmΩ

MARKER READOUT
FUNCTIONS